

Transmitter Occupied Bandwidth (Bandwidth Limitations) (continued)

Results: 5 MHz / SF128 / Vertical

Channel	RBW (kHz)	VBW (kHz)	Occupied Bandwidth (MHz)
Bottom	100	300	4.395
Middle	100	300	4.292
Top	100	300	5.837

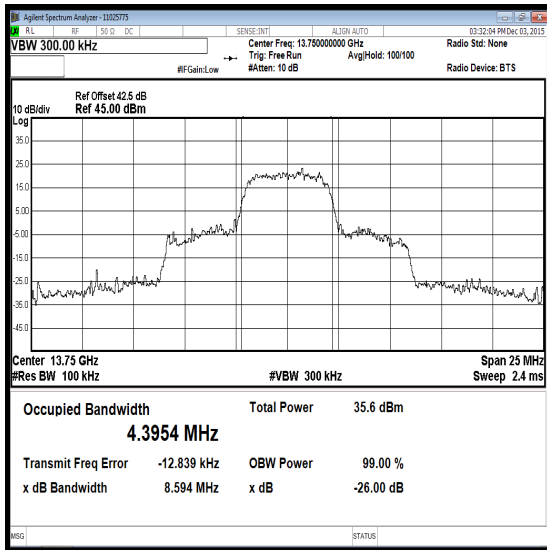

Bottom Channel

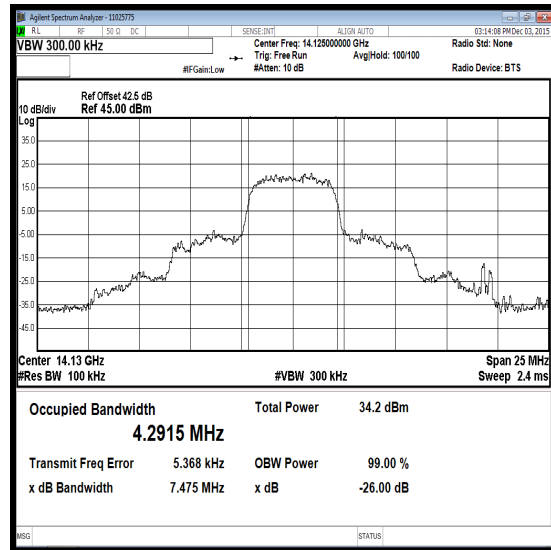

Middle Channel

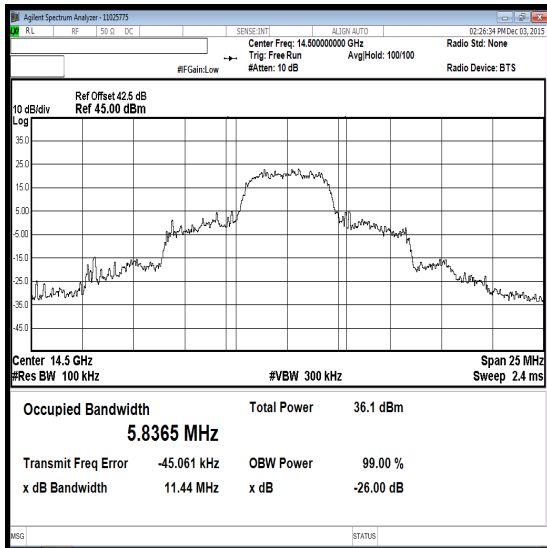

Top Channel

Transmitter Occupied Bandwidth (Bandwidth Limitations) (continued)

Results: 5 MHz / SF128 / Horizontal

Channel	RBW (kHz)	VBW (kHz)	Occupied Bandwidth (MHz)
Bottom	100	300	5.094
Middle	100	300	4.503
Top	100	300	5.529

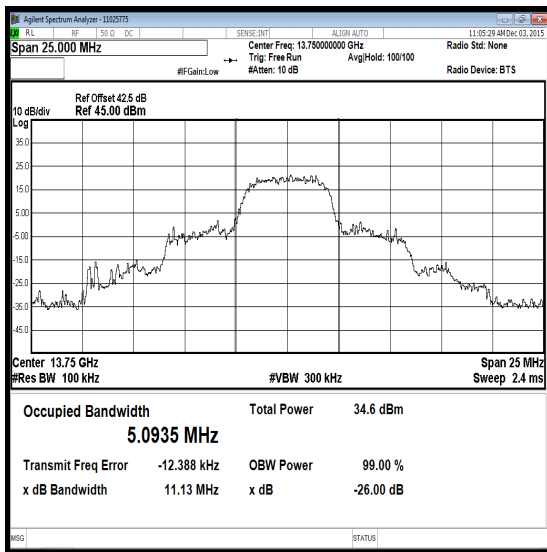

Bottom Channel

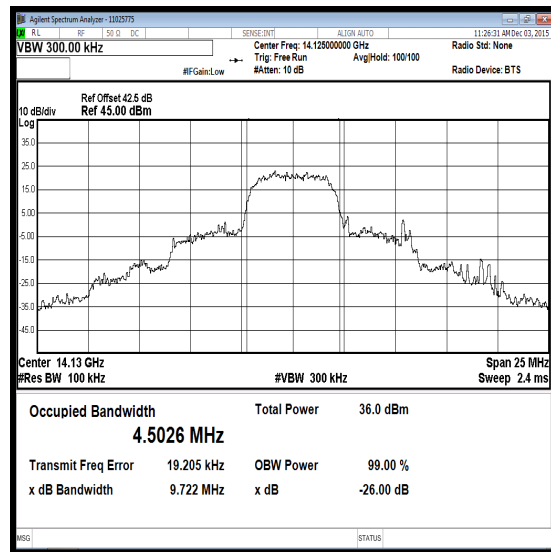

Middle Channel

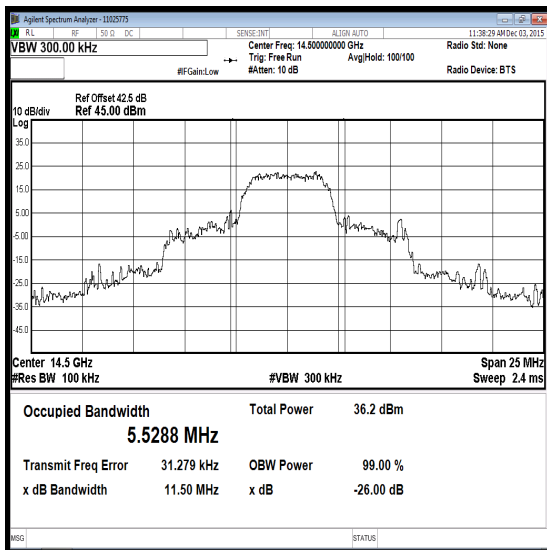

Top Channel

Transmitter Occupied Bandwidth (Bandwidth Limitations) (continued)

Results: 5 MHz / SF64 / Vertical

Channel	RBW (kHz)	VBW (kHz)	Occupied Bandwidth (MHz)
Bottom	100	300	4.401
Middle	100	300	4.320
Top	100	300	5.259

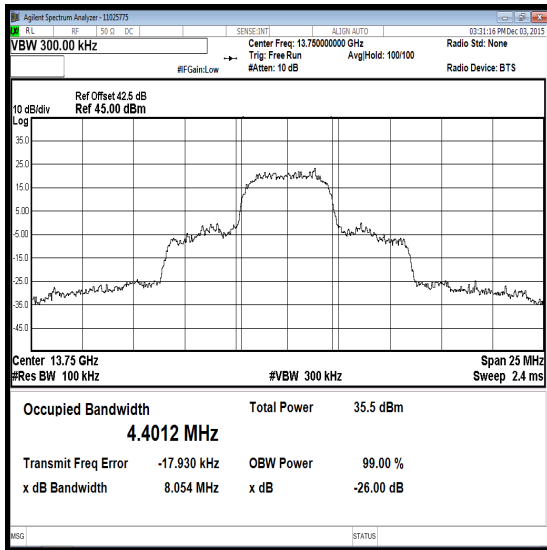

Bottom Channel

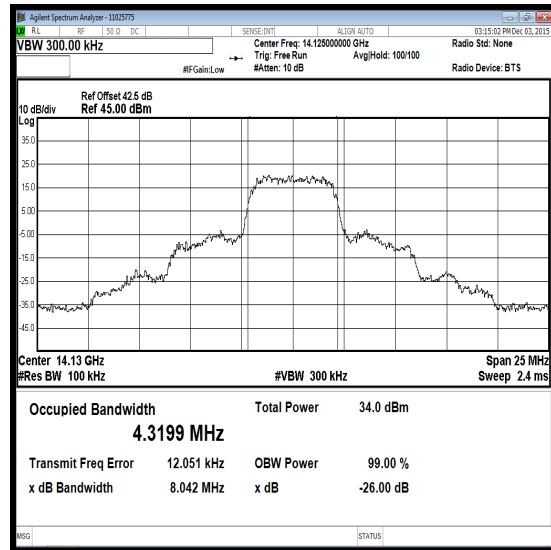

Middle Channel

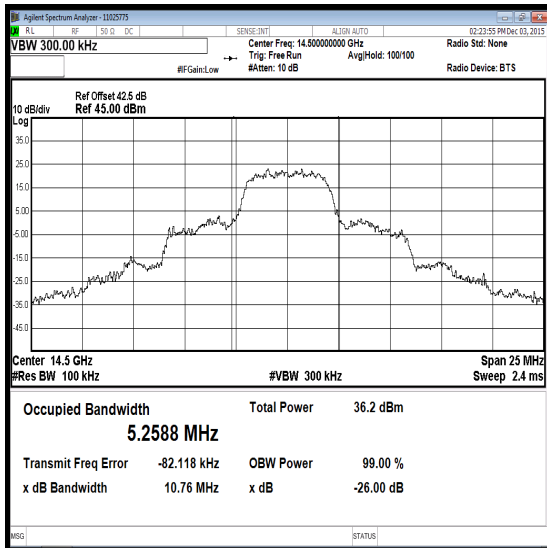

Top Channel

Transmitter Occupied Bandwidth (Bandwidth Limitations) (continued)

Results: 5 MHz / SF64 / Horizontal

Channel	RBW (kHz)	VBW (kHz)	Occupied Bandwidth (MHz)
Bottom	100	300	5.152
Middle	100	300	4.414
Top	100	300	4.672

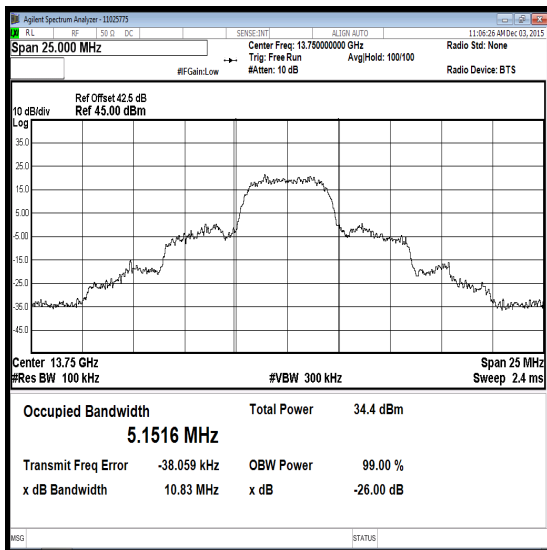

Bottom Channel

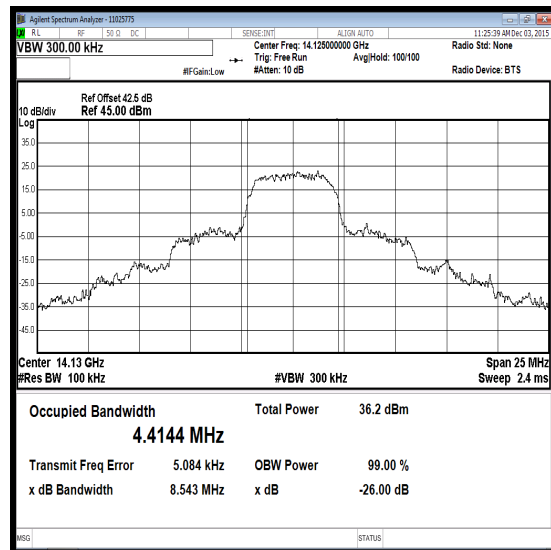

Middle Channel

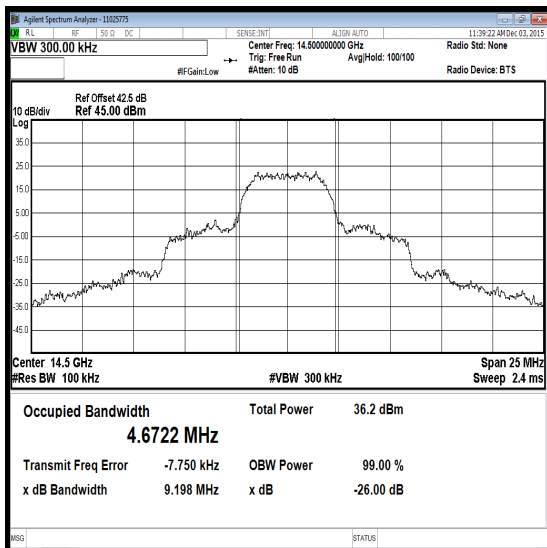

Top Channel

Transmitter Occupied Bandwidth (Bandwidth Limitations) (continued)

Results: 5 MHz / SF32 / Vertical

Channel	RBW (kHz)	VBW (kHz)	Occupied Bandwidth (MHz)
Bottom	100	300	4.407
Middle	100	300	4.313
Top	100	300	5.119

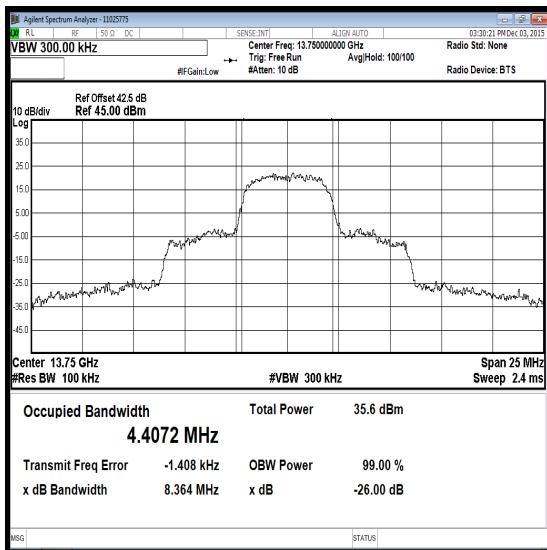

Bottom Channel

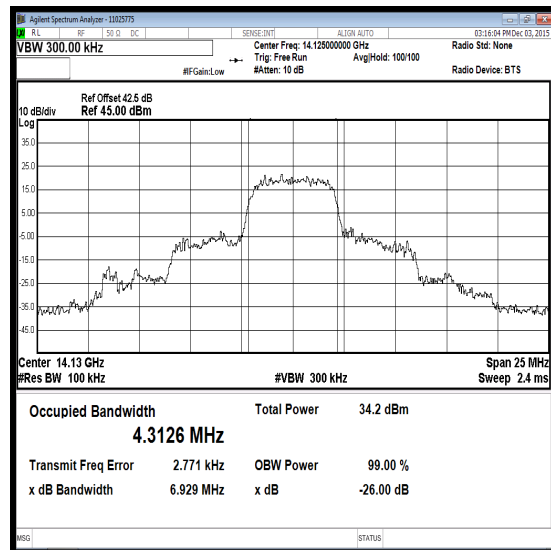

Middle Channel

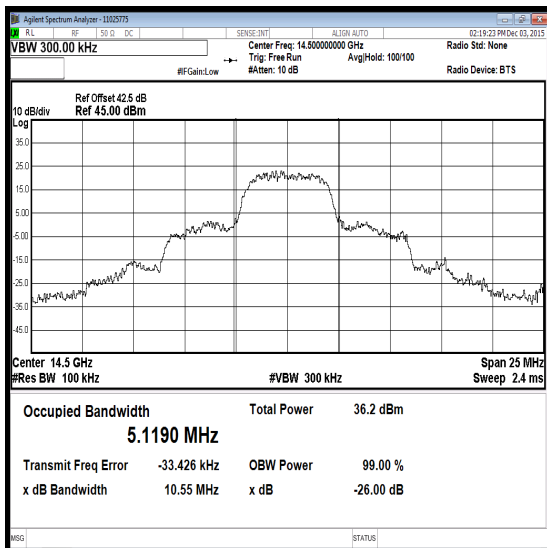

Top Channel

Transmitter Occupied Bandwidth (Bandwidth Limitations) (continued)

Results: 5 MHz / SF32 / Horizontal

Channel	RBW (kHz)	VBW (kHz)	Occupied Bandwidth (MHz)
Bottom	100	300	5.188
Middle	100	300	4.435
Top	100	300	4.820

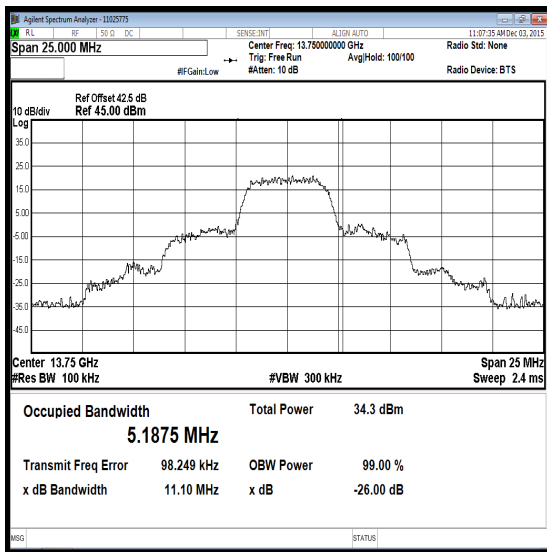

Bottom Channel

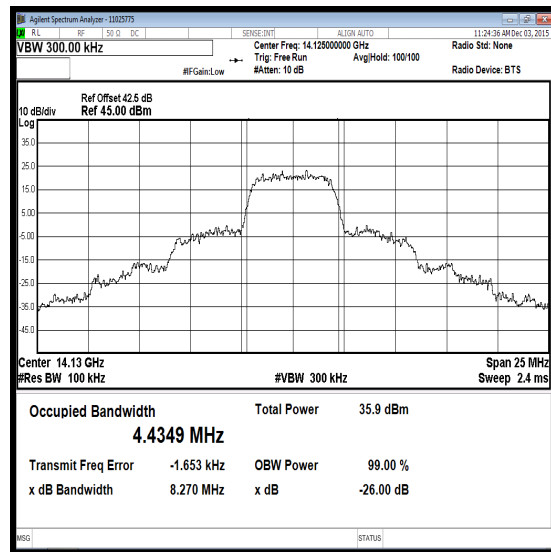

Middle Channel

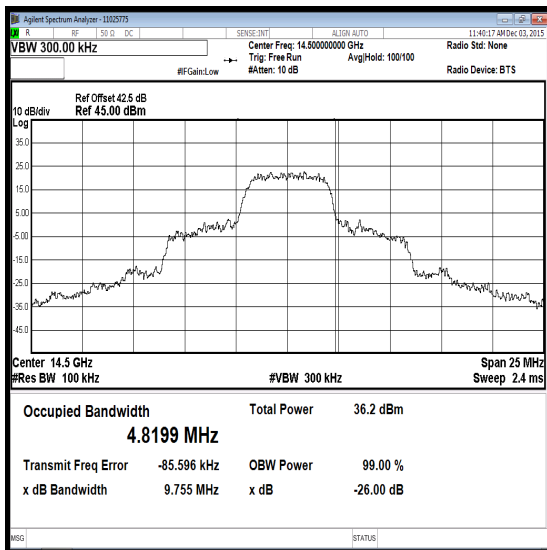

Top Channel

Transmitter Occupied Bandwidth (Bandwidth Limitations) (continued)

Results: 5 MHz / SF16 / Vertical

Channel	RBW (kHz)	VBW (kHz)	Occupied Bandwidth (MHz)
Bottom	100	300	4.397
Middle	100	300	4.297
Top	100	300	5.522

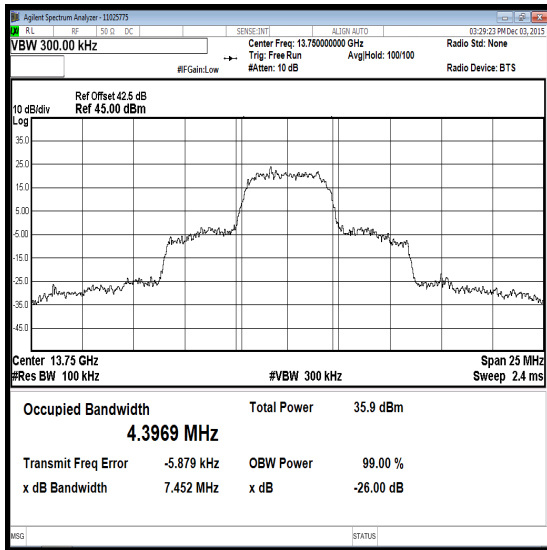

Bottom Channel

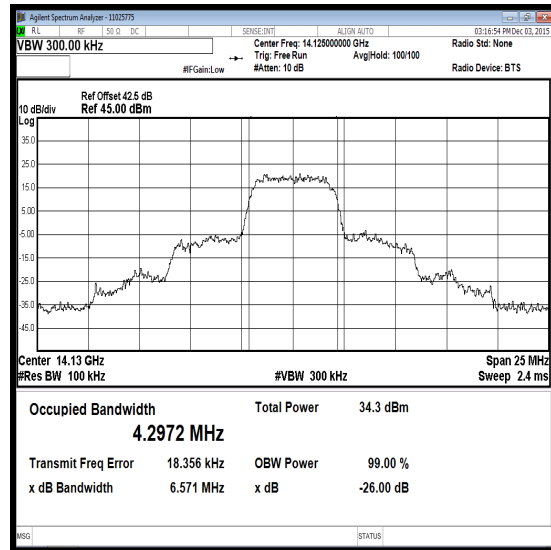

Middle Channel

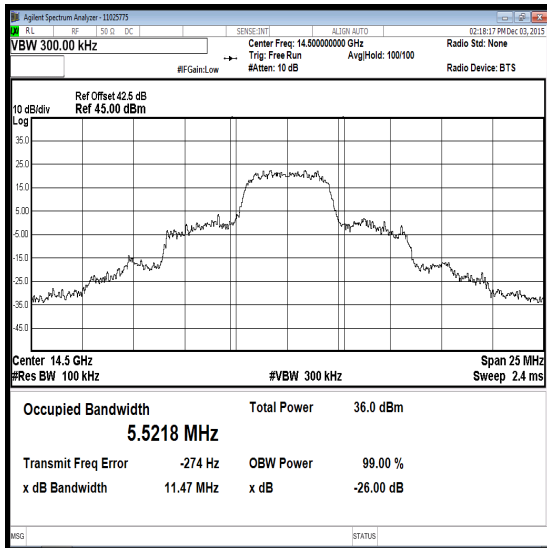

Top Channel

Transmitter Occupied Bandwidth (Bandwidth Limitations) (continued)

Results: 5 MHz / SF16 / Horizontal

Channel	RBW (kHz)	VBW (kHz)	Occupied Bandwidth (MHz)
Bottom	100	300	5.103
Middle	100	300	4.443
Top	100	300	4.692

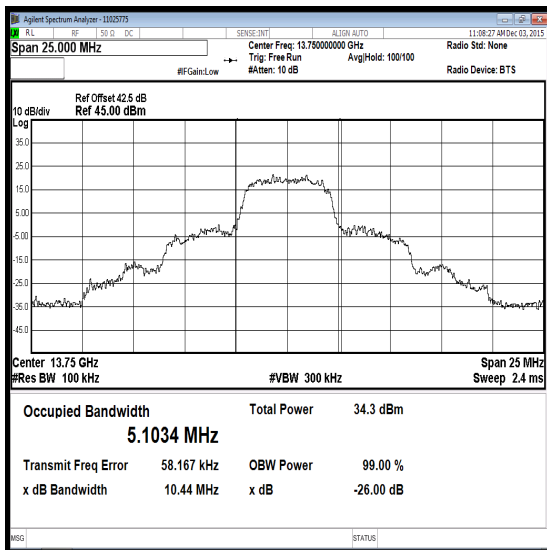

Bottom Channel

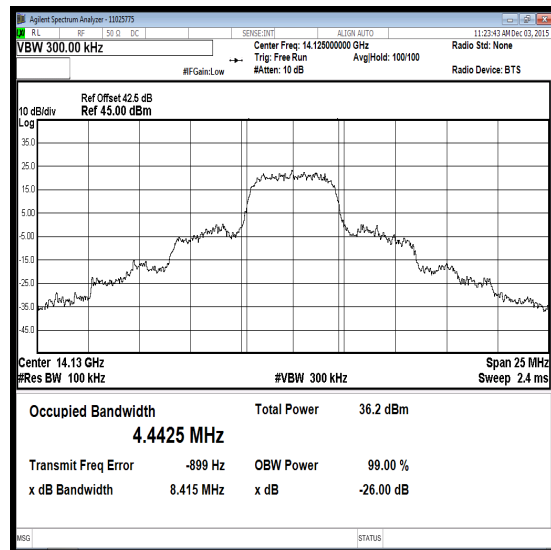

Middle Channel

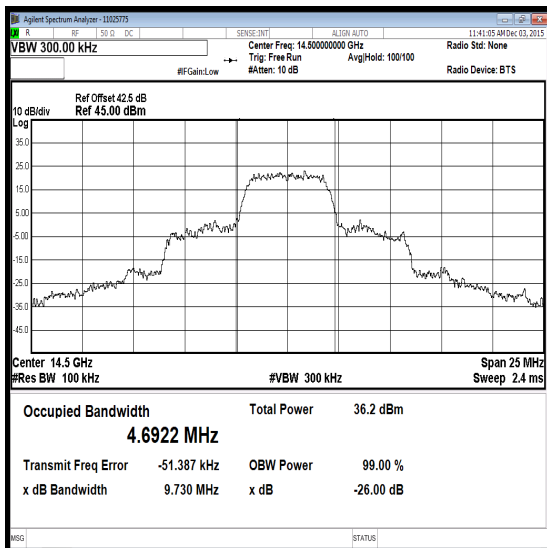

Top Channel

Transmitter Occupied Bandwidth (Bandwidth Limitations) (continued)

Results: 10 MHz / SF256 / Vertical

Channel	RBW (kHz)	VBW (kHz)	Occupied Bandwidth (MHz)
Bottom	300	1000	8.700
Middle	300	1000	8.500
Top	300	1000	9.708

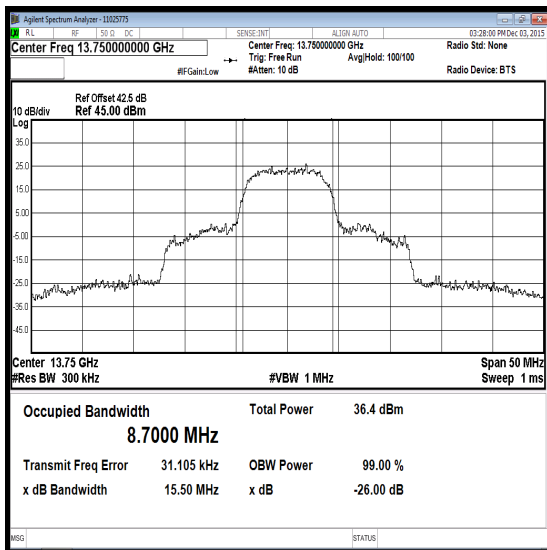

Bottom Channel

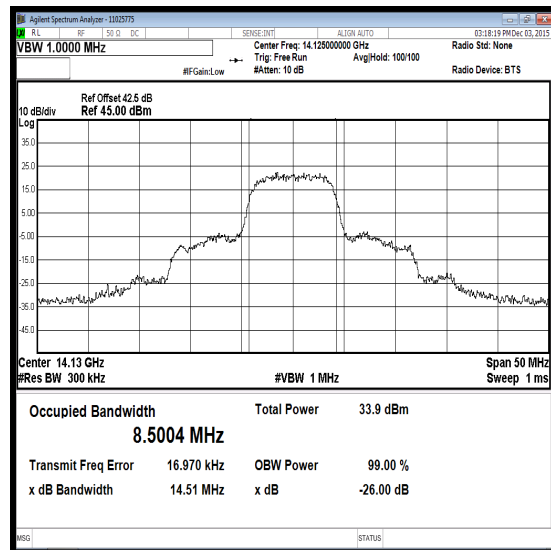

Middle Channel

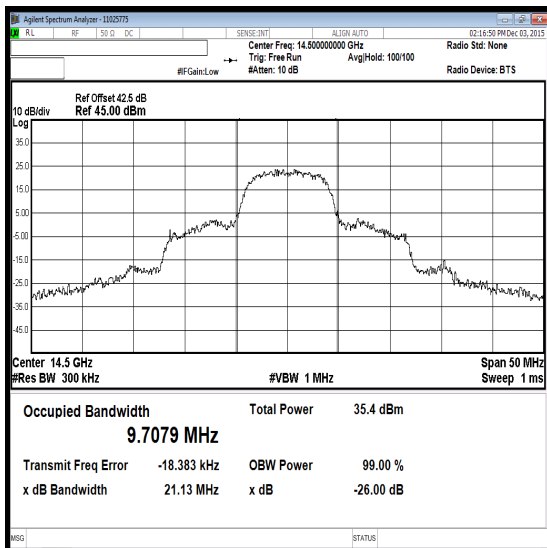

Top Channel

Transmitter Occupied Bandwidth (Bandwidth Limitations) (continued)

Results: 10 MHz / SF256 / Horizontal

Channel	RBW (kHz)	VBW (kHz)	Occupied Bandwidth (MHz)
Bottom	200	1000	9.323
Middle	200	1000	8.681
Top	300	1000	8.927

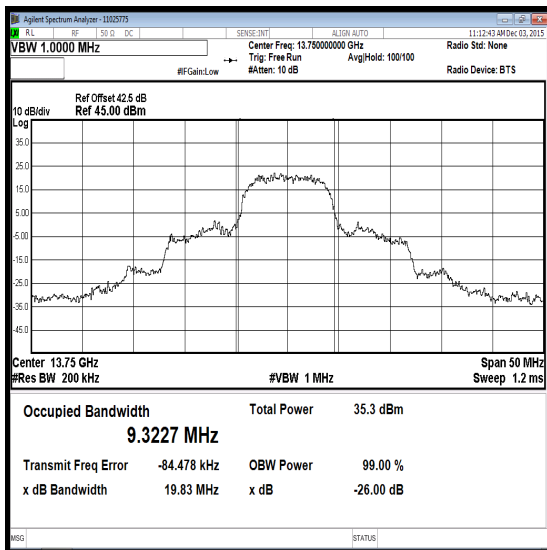

Bottom Channel

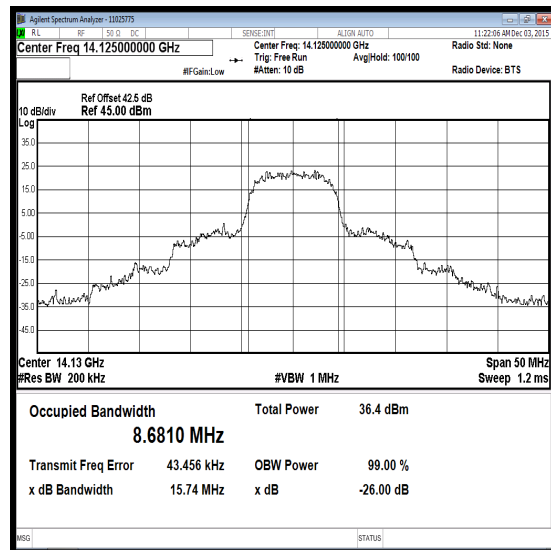

Middle Channel

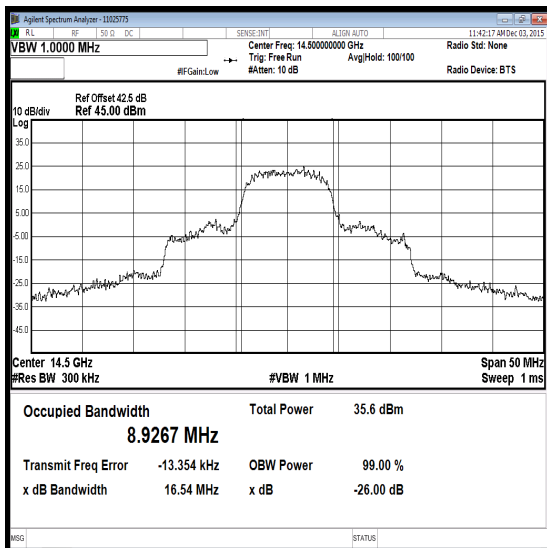

Top Channel

Transmitter Occupied Bandwidth (Bandwidth Limitations) (continued)

Results: 10 MHz / SF128 / Vertical

Channel	RBW (kHz)	VBW (kHz)	Occupied Bandwidth (MHz)
Bottom	300	1000	8.761
Middle	300	1000	8.625
Top	300	1000	9.840

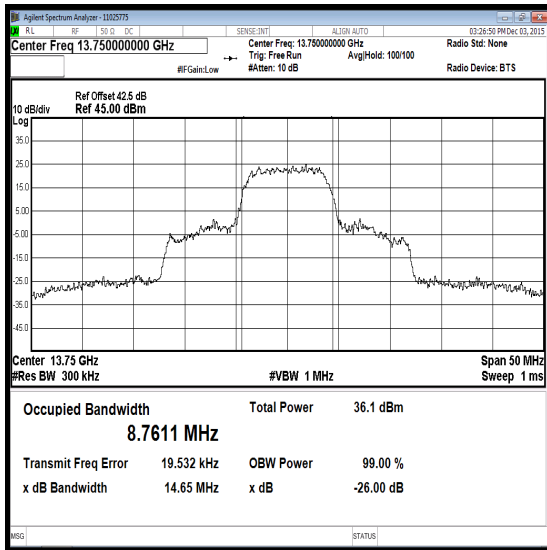

Bottom Channel

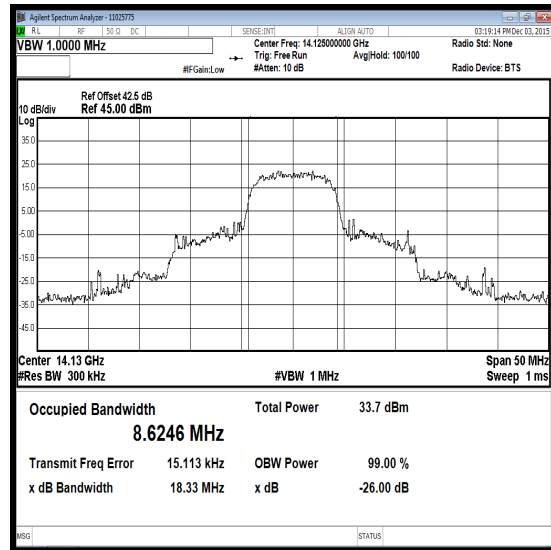

Middle Channel

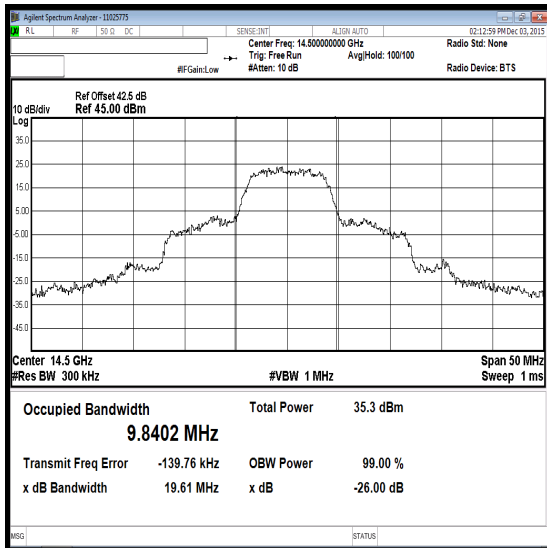

Top Channel

Transmitter Occupied Bandwidth (Bandwidth Limitations) (continued)

Results: 10 MHz / SF128 / Horizontal

Channel	RBW (kHz)	VBW (kHz)	Occupied Bandwidth (MHz)
Bottom	200	1000	10.331
Middle	200	1000	8.756
Top	300	1000	9.041

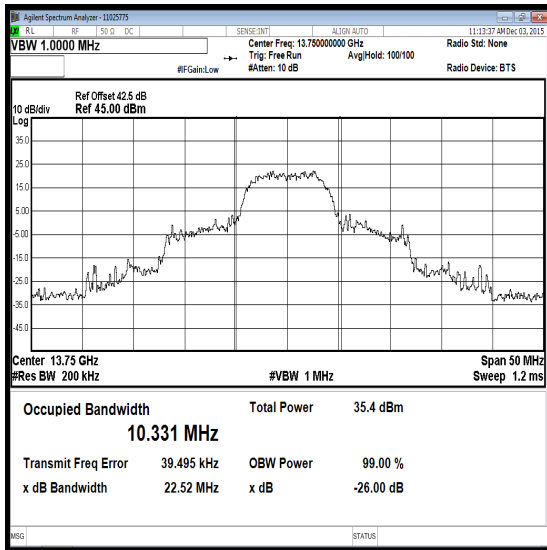

Bottom Channel

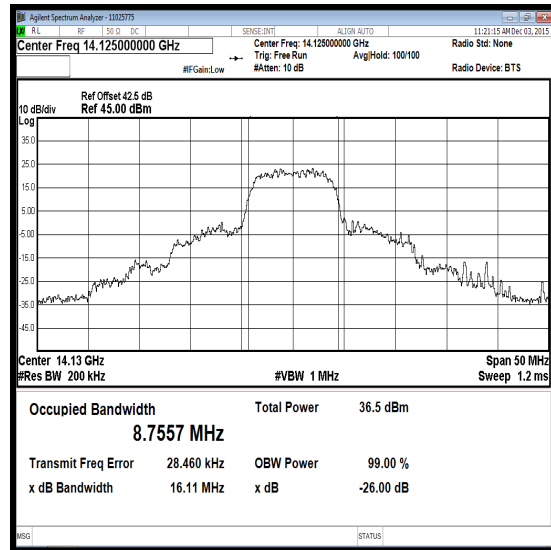

Middle Channel

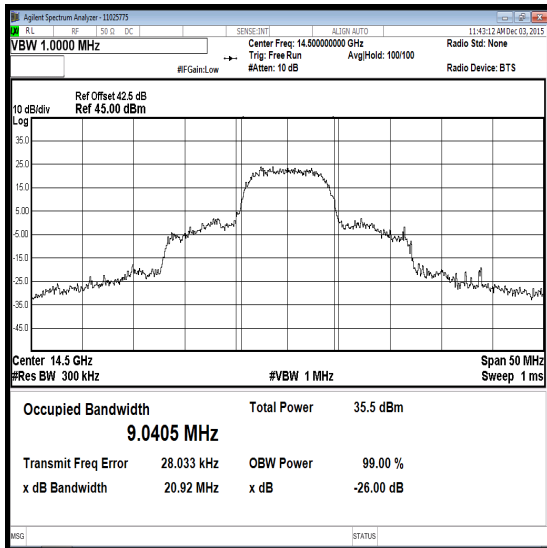

Top Channel

Transmitter Occupied Bandwidth (Bandwidth Limitations) (continued)

Results: 10 MHz / SF64 / Vertical

Channel	RBW (kHz)	VBW (kHz)	Occupied Bandwidth (MHz)
Bottom	300	1000	8.752
Middle	300	1000	8.520
Top	300	1000	9.829

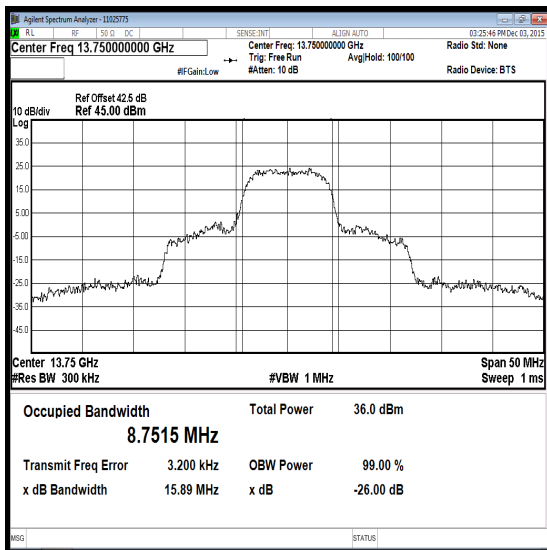

Bottom Channel

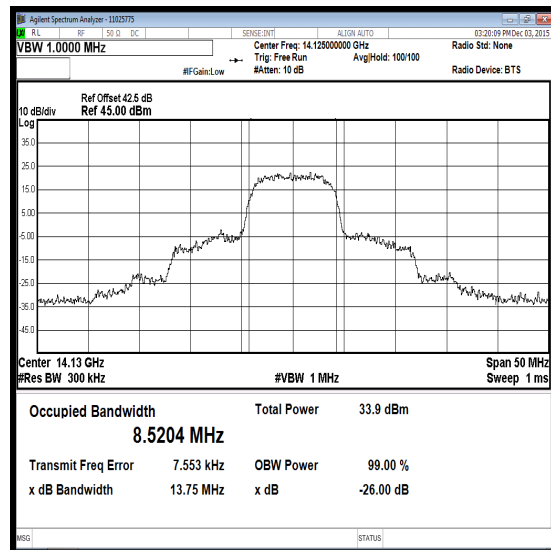

Middle Channel

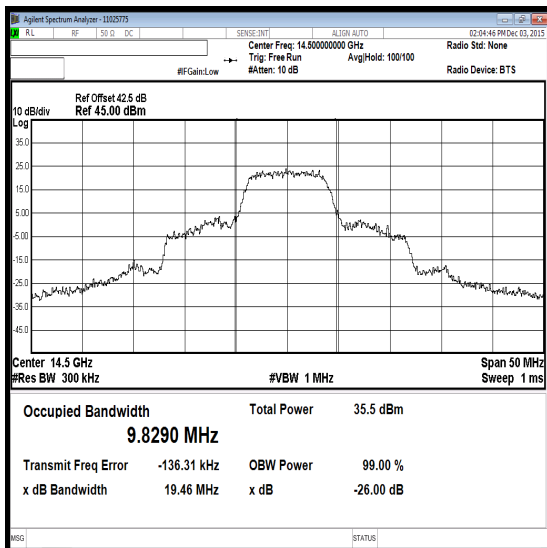

Top Channel

Transmitter Occupied Bandwidth (Bandwidth Limitations) (continued)

Results: 10 MHz / SF64 / Horizontal

Channel	RBW (kHz)	VBW (kHz)	Occupied Bandwidth (MHz)
Bottom	200	1000	9.284
Middle	200	1000	8.746
Top	300	1000	8.937

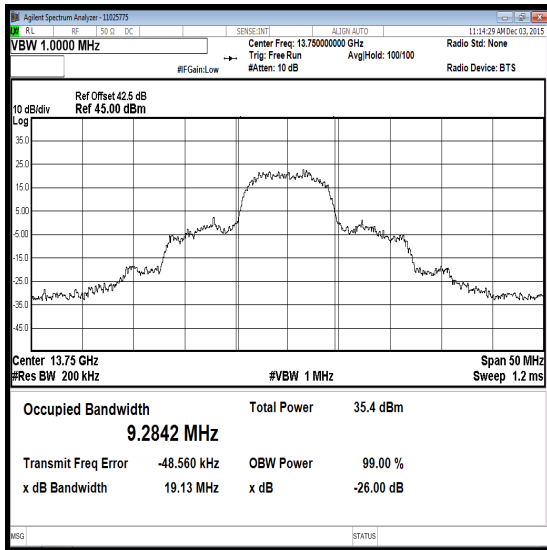

Bottom Channel

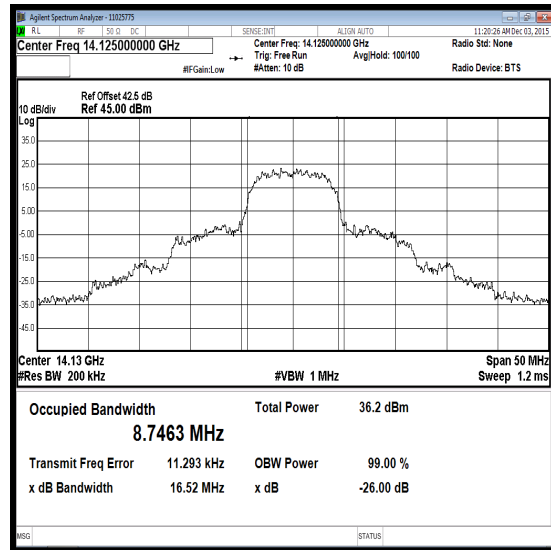

Middle Channel

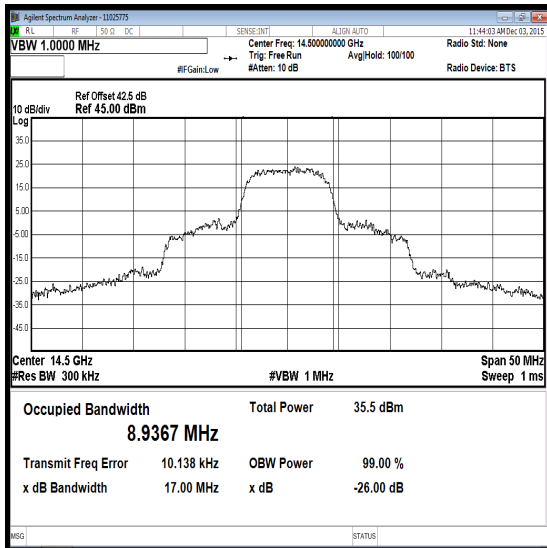

Top Channel

Transmitter Occupied Bandwidth (Bandwidth Limitations) (continued)

Results: 10 MHz / SF32 / Vertical

Channel	RBW (kHz)	VBW (kHz)	Occupied Bandwidth (MHz)
Bottom	300	1000	8.655
Middle	300	1000	8.542
Top	300	1000	9.660

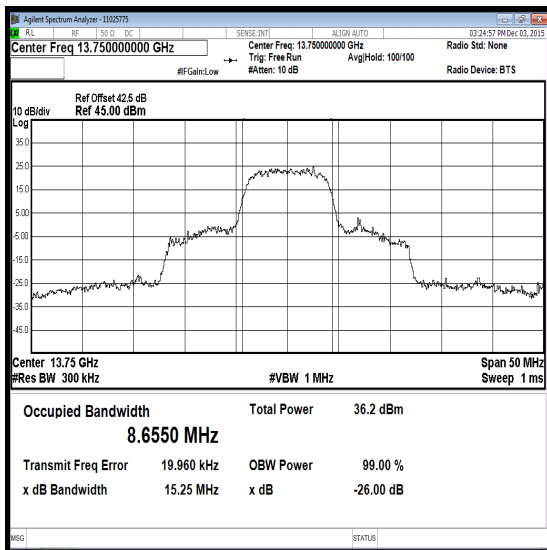

Bottom Channel

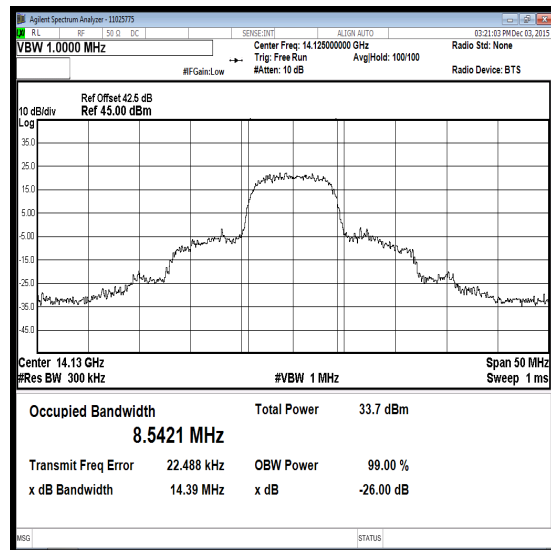

Middle Channel

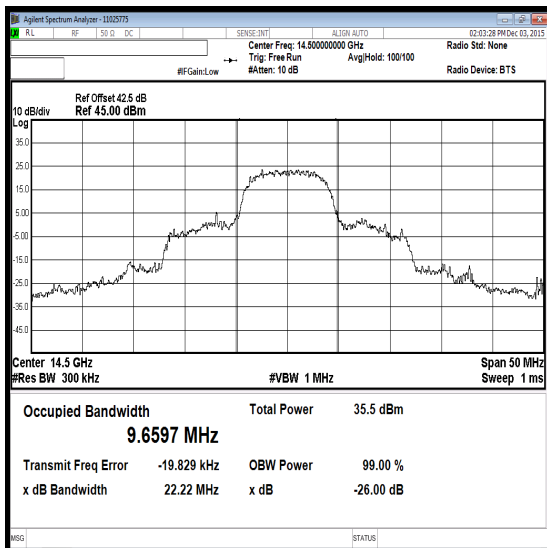

Top Channel

Transmitter Occupied Bandwidth (Bandwidth Limitations) (continued)

Results: 10 MHz / SF32 / Horizontal

Channel	RBW (kHz)	VBW (kHz)	Occupied Bandwidth (MHz)
Bottom	200	1000	9.322
Middle	200	1000	8.766
Top	300	1000	8.968

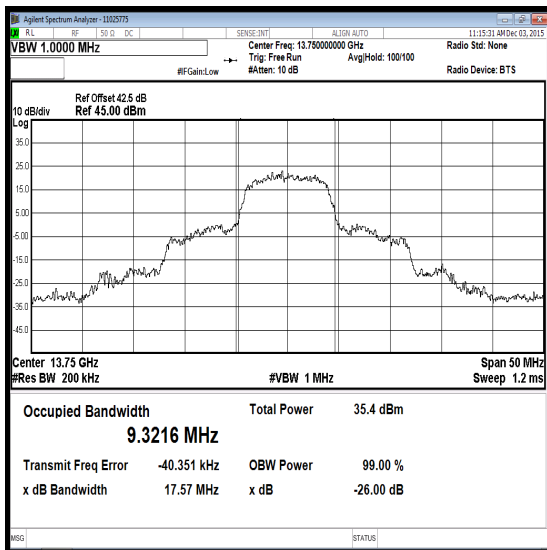

Bottom Channel

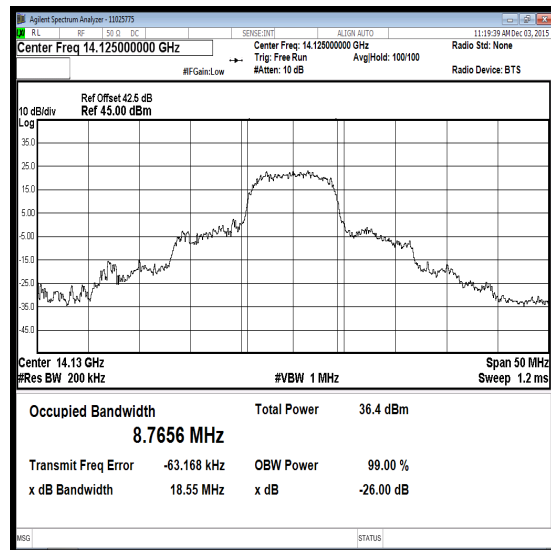

Middle Channel

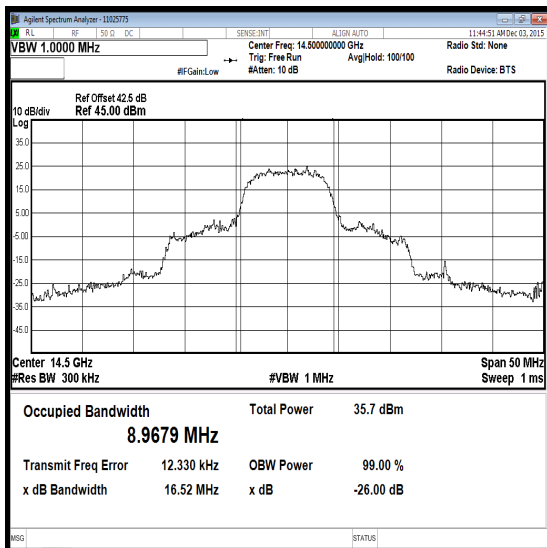

Top Channel

Transmitter Occupied Bandwidth (Bandwidth Limitations) (continued)

Results: 10 MHz / SF16 / Vertical

Channel	RBW (kHz)	VBW (kHz)	Occupied Bandwidth (MHz)
Bottom	300	1000	8.744
Middle	300	1000	8.578
Top	300	1000	9.735

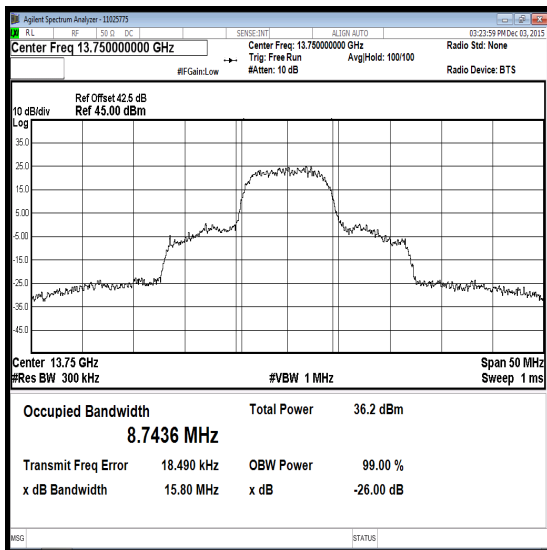

Bottom Channel

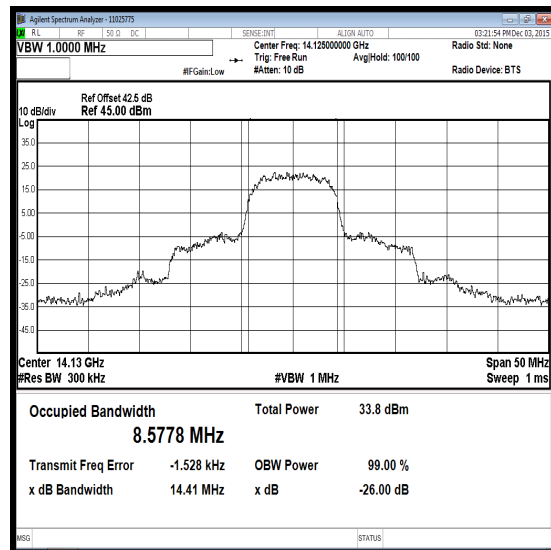

Middle Channel

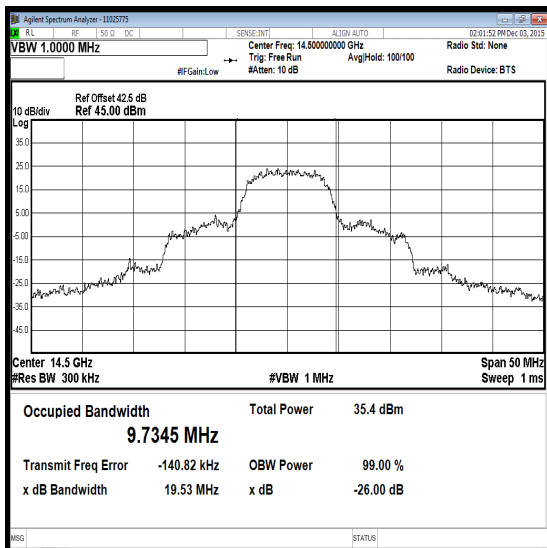

Top Channel

Transmitter Occupied Bandwidth (Bandwidth Limitations) (continued)

Results: 10 MHz / SF16 / Horizontal

Channel	RBW (kHz)	VBW (kHz)	Occupied Bandwidth (MHz)
Bottom	200	1000	9.039
Middle	200	1000	8.764
Top	300	1000	8.952

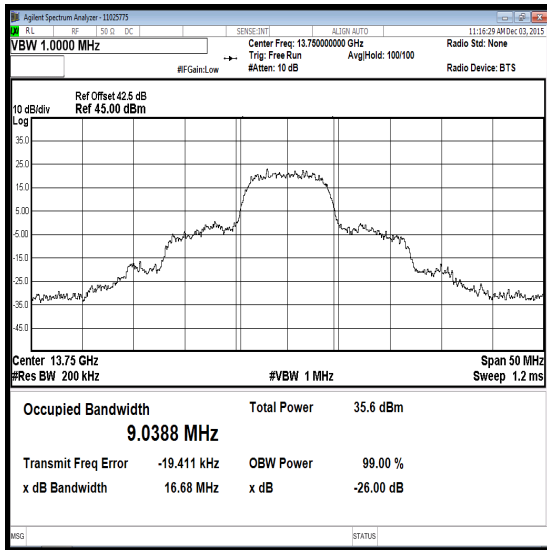

Bottom Channel

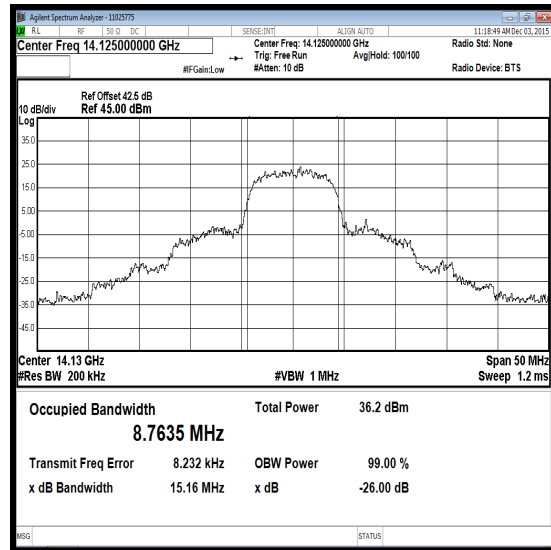

Middle Channel

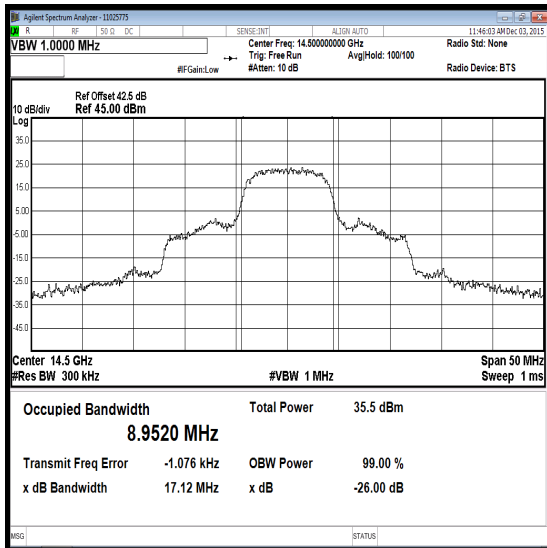

Top Channel

Transmitter Occupied Bandwidth (Bandwidth Limitations) (continued)**Test Equipment Used:**

Asset No.	Instrument	Manufacturer	Type No.	Serial No.	Date Calibration Due	Cal. Interval (Months)
M1659	Thermohygrometer	JM Handelpunkt	30.5015.13	Not stated	23 Apr 2016	12
A2526	Attenuator	AtlanTecRF	AN18W5-20	832828#1	Calibrated before use	-
A2523	Attenuator	AtlanTecRF	AN18W5-10	832827#1	Calibrated before use	-
A2524	Attenuator	AtlanTecRF	AN18W5-10	832827#2	Calibrated before use	-
C1363	Coax Cable	Rosenberger Micro-Coax	FA147A	68088-01	Calibrated before use	-
M1832	Spectrum Analyser	Agilent	N9010A	MY53470303	26 Mar 2016	24
G085	Signal Generator	Hewlett Packard	83650L	3614A00104	11 Nov 2016	24
M1145	Power Meter	Hewlett Packard	437B	3737U26557	11 Aug 2016	12
M1592	Power Sensor	Hewlett Packard	8487A	3318A02094	22 Sep 2016	12
A2554	Terminator	Micronde	R404610	Not stated	Calibrated before use	-
A2555	Terminator	Micronde	R404610	Not stated	Calibrated before use	-

5.2.3. Transmitter Conducted Emissions Masks**Test Summary:**

Test Engineer:	Ben Mercer	Test Dates:	07 December 2015 & 08 December 2015
Test Sample Serial Numbers:	311510061 & 3115155009		

FCC Reference:	Parts 25.202(f) & 2.1051
Test Method Used:	FCC KDB 971168 Section 5.2.3 & 6

Environmental Conditions:

Temperature (°C):	22 to 24
Relative Humidity (%):	47 to 49

Note(s):

1. The top of the mask was referenced to the average conducted power measured using a power meter in accordance with KDB 971168 section 5.2.3.
2. Part 25.202(f) specifies emissions limitations in a 4 kHz bandwidth. The closest selectable resolution bandwidth of 4.3 kHz was set, and video bandwidth was set to 13 kHz. The number of measurement points was set to at least 2 x span / resolution bandwidth. An RMS detector was used, sweep time was set to auto and trace averaging was employed over 100 traces.
3. The spectrum analyser was connected to the antenna port on the EUT using suitable attenuation and coaxial cable. A reference level offset was entered on the spectrum analyser to compensate for the loss of the attenuator and coaxial cable.
4. The customer provided an OMT to adapt the circular waveguide flange at the antenna port to rectangular flanges to enable conducted measurements. The customer stated the worst case loss of the OMT as 0.5 dB. This loss was included in the reference level offset entered on the spectrum analyser.

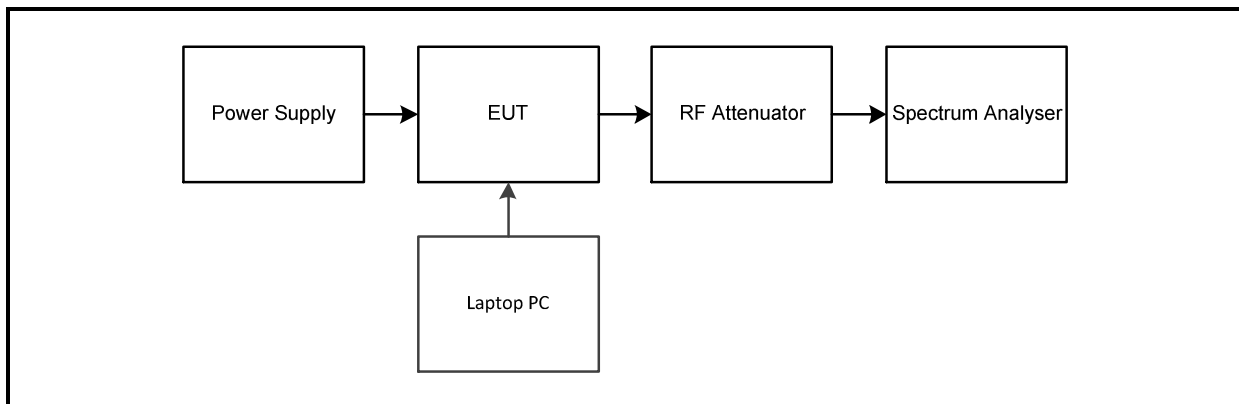
Test setup:

Transmitter Conducted Emissions Masks (continued)

Results: 2.5 MHz / SF128 / Vertical

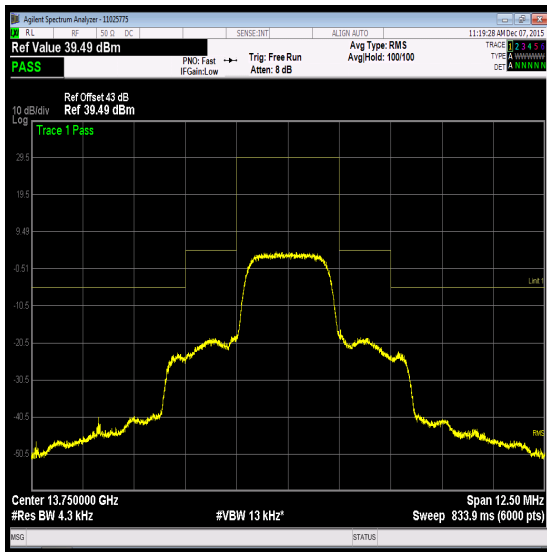

Bottom Channel

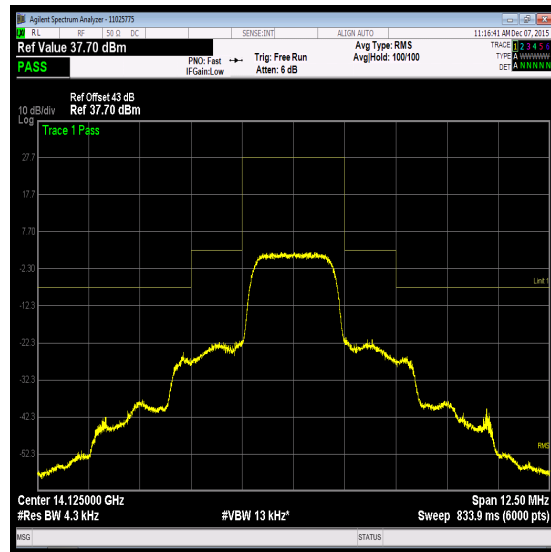

Middle Channel

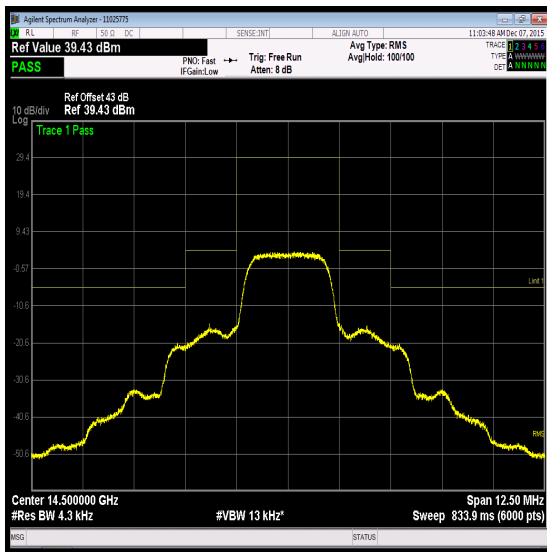

Top Channel

Transmitter Conducted Emissions Masks (continued)

Results: 2.5 MHz / SF128 / Horizontal

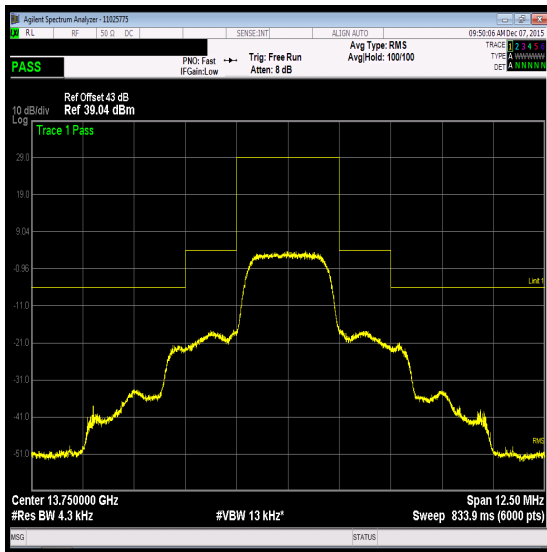

Bottom Channel

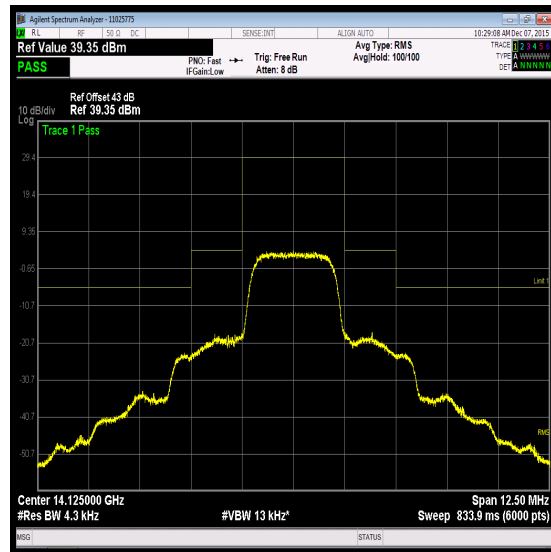

Middle Channel

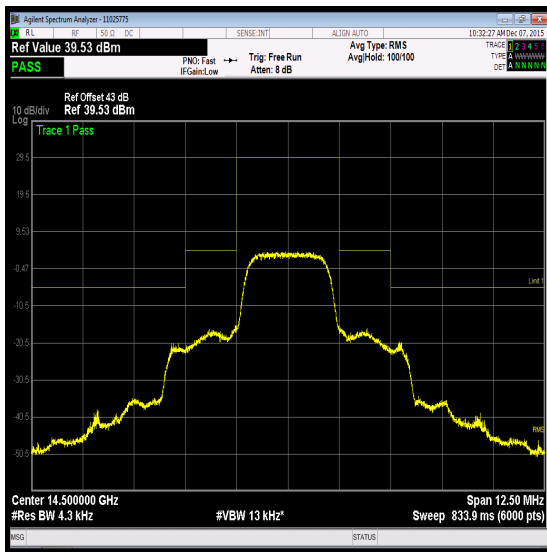

Top Channel

Transmitter Conducted Emissions Masks (continued)

Results: 2.5 MHz / SF64 / Vertical

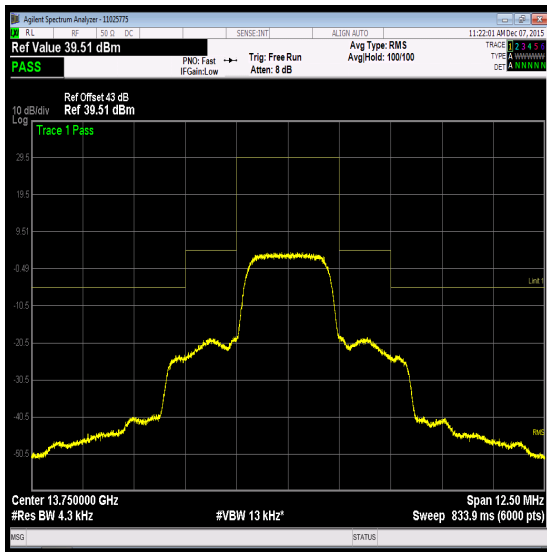

Bottom Channel

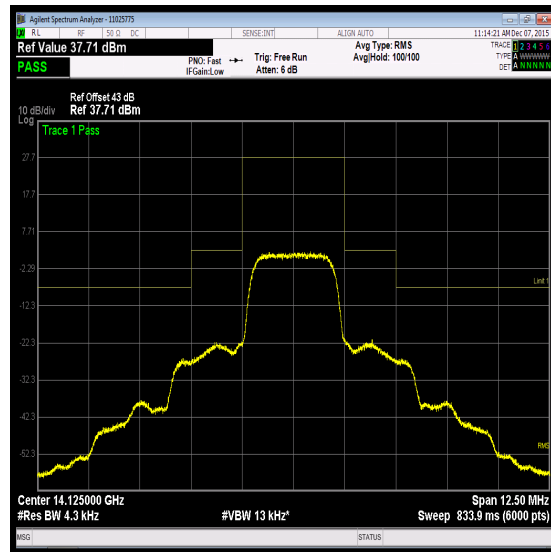

Middle Channel

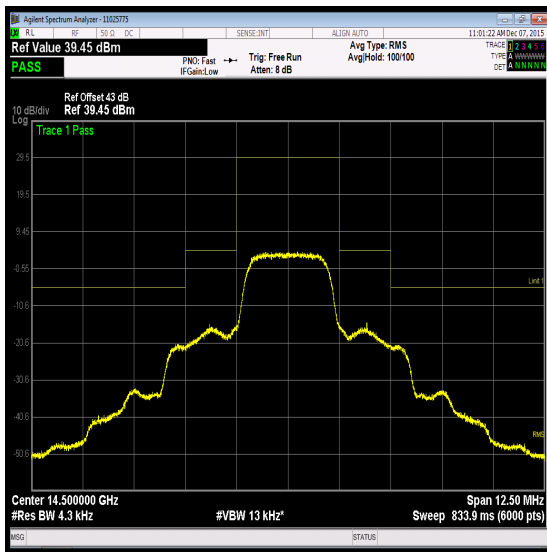

Top Channel

Transmitter Conducted Emissions Masks (continued)

Results: 2.5 MHz / SF64 / Horizontal

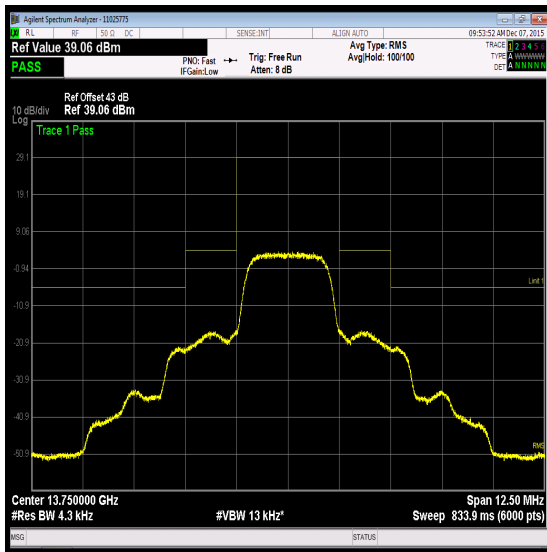

Bottom Channel

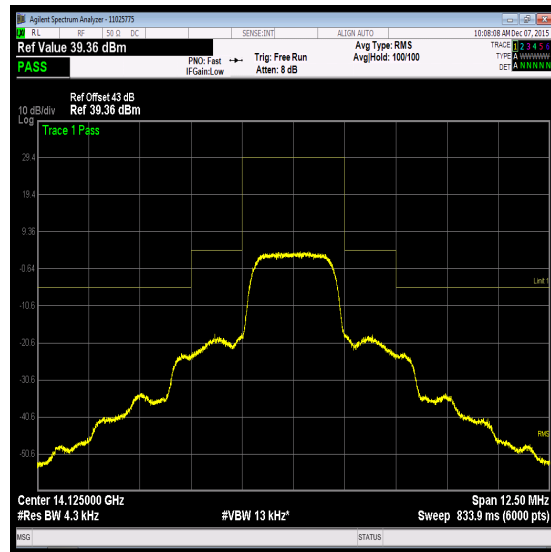

Middle Channel

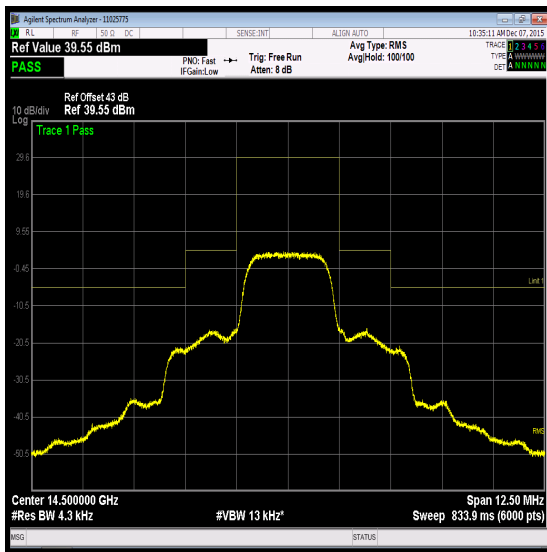

Top Channel

Transmitter Conducted Emissions Masks (continued)

Results: 2.5 MHz / SF32 / Vertical

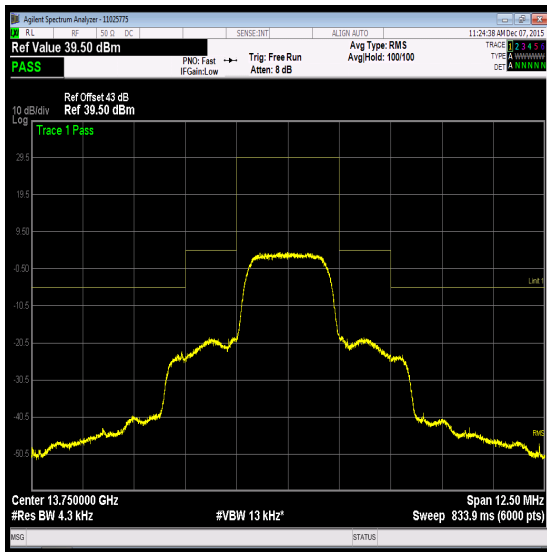

Bottom Channel

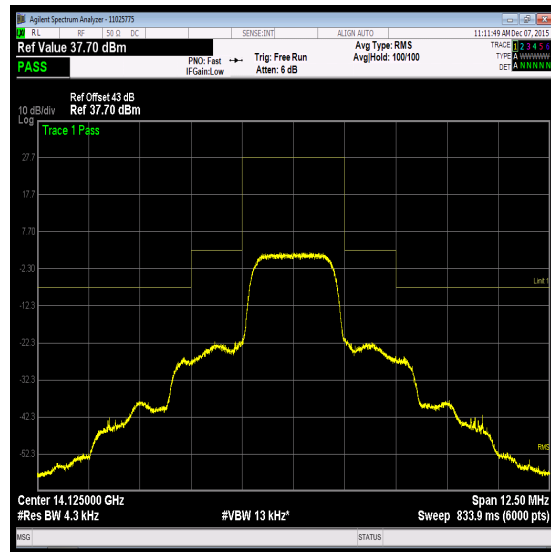

Middle Channel

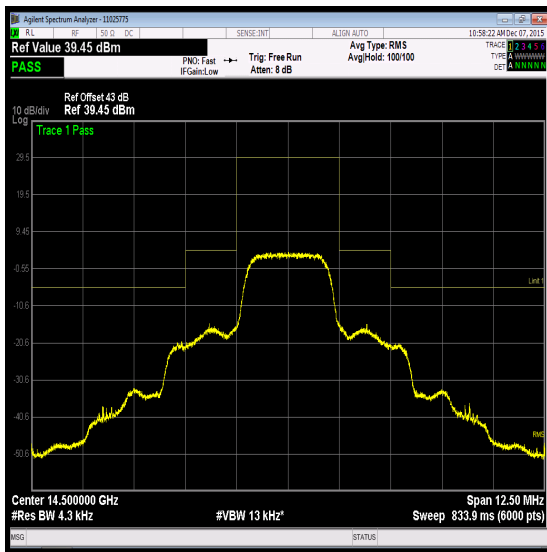

Top Channel

Transmitter Conducted Emissions Masks (continued)

Results: 2.5 MHz / SF32 / Horizontal

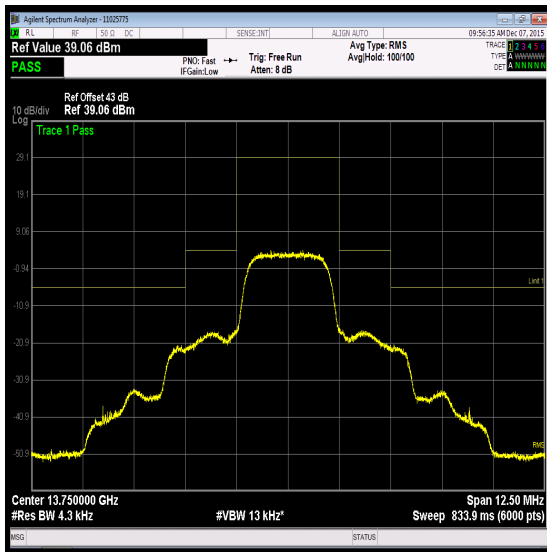

Bottom Channel

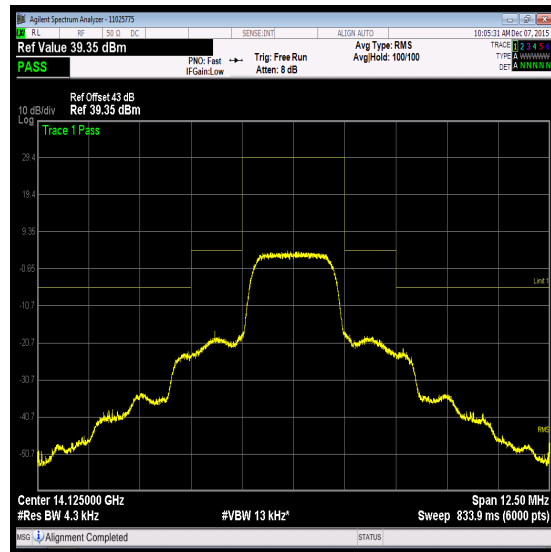

Middle Channel

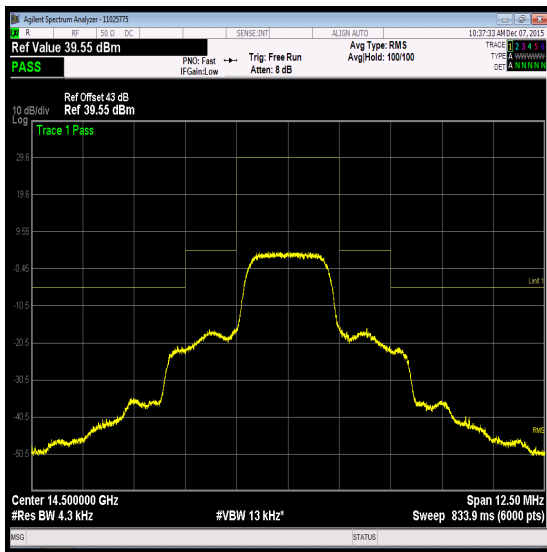

Top Channel

Transmitter Conducted Emissions Masks (continued)

Results: 2.5 MHz / SF16 / Vertical

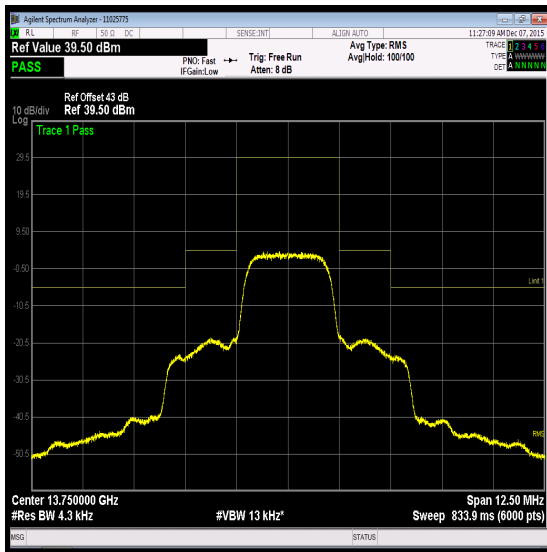

Bottom Channel

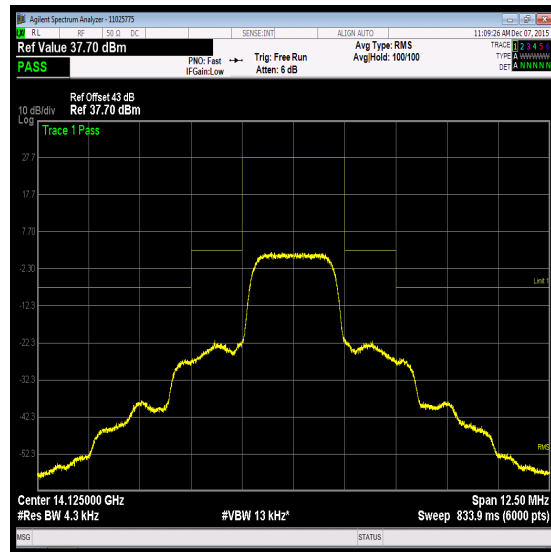

Middle Channel

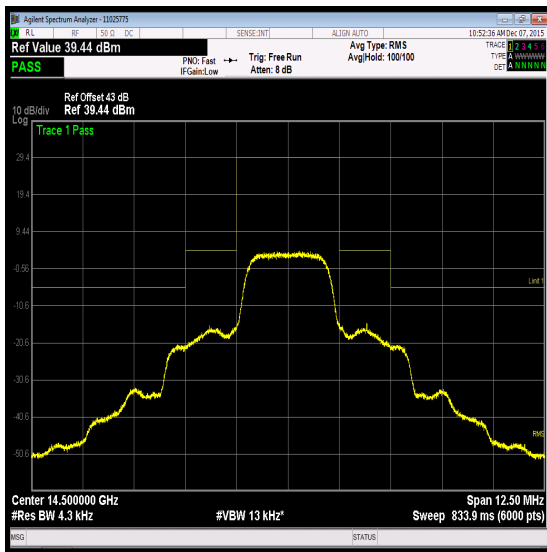

Top Channel

Transmitter Conducted Emissions Masks (continued)

Results: 2.5 MHz / SF16 / Horizontal

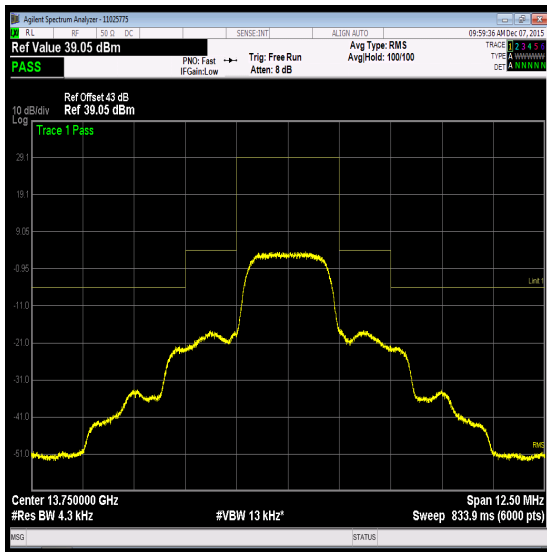

Bottom Channel

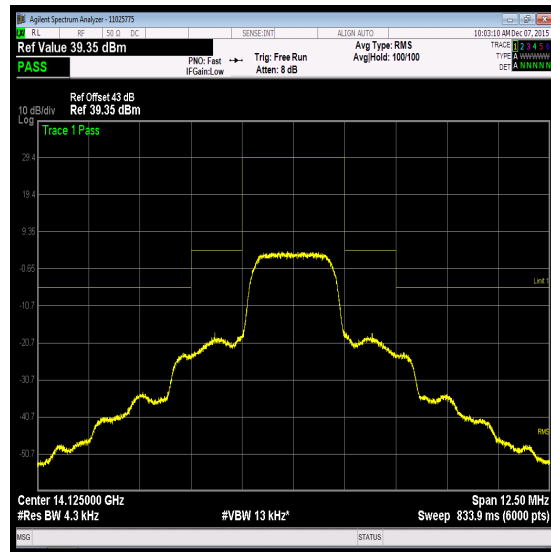

Middle Channel

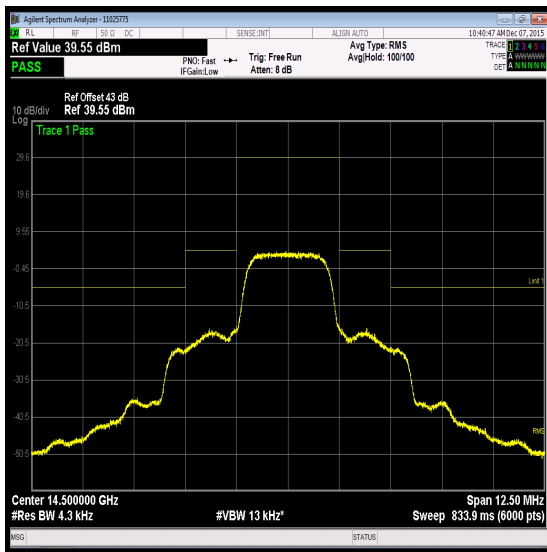

Top Channel

Transmitter Conducted Emissions Masks (continued)

Results: 5 MHz / SF256 / Vertical

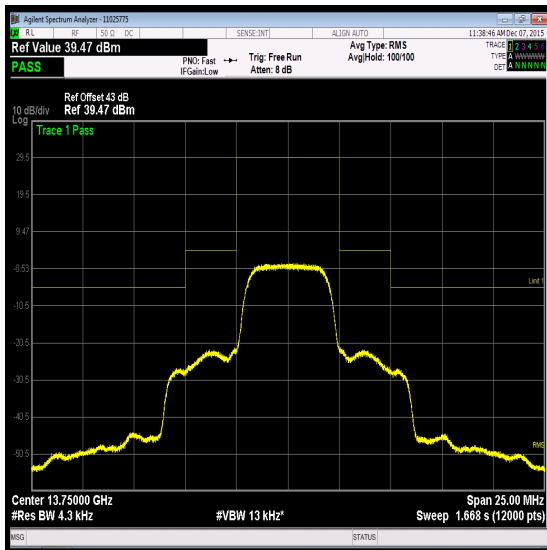

Bottom Channel

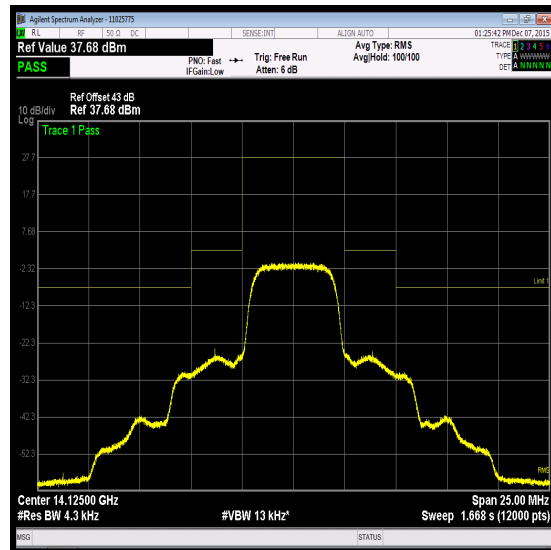

Middle Channel

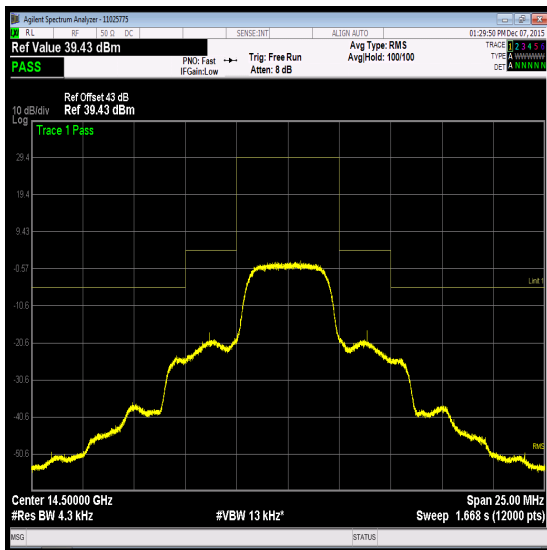

Top Channel

Transmitter Conducted Emissions Masks (continued)

Results: 5 MHz / SF256 / Horizontal

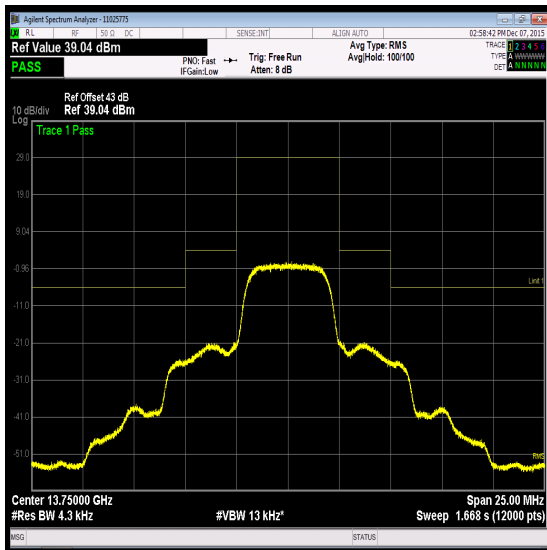

Bottom Channel

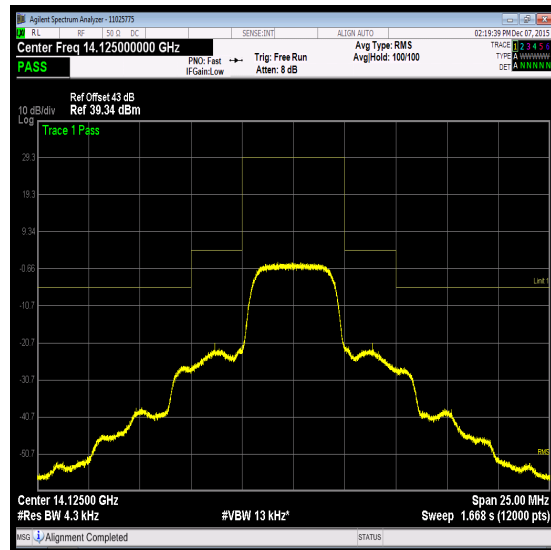

Middle Channel

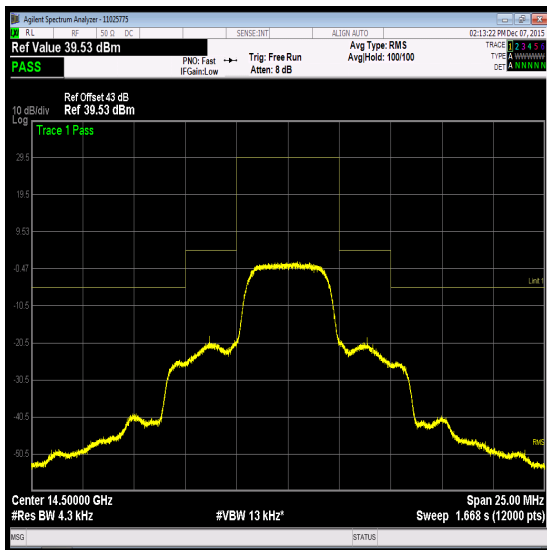

Top Channel

Transmitter Conducted Emissions Masks (continued)

Results: 5 MHz / SF128 / Vertical

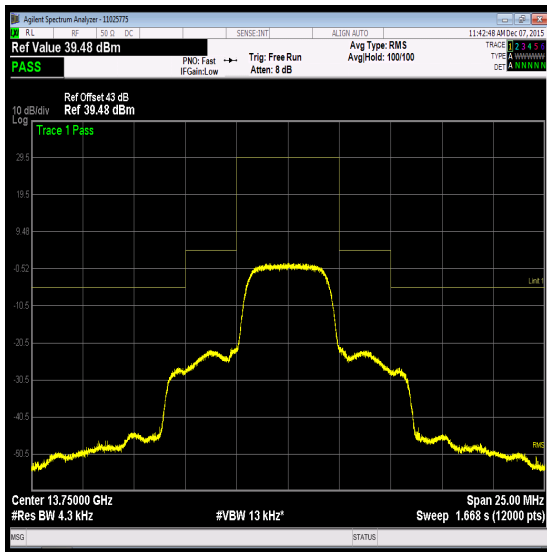

Bottom Channel

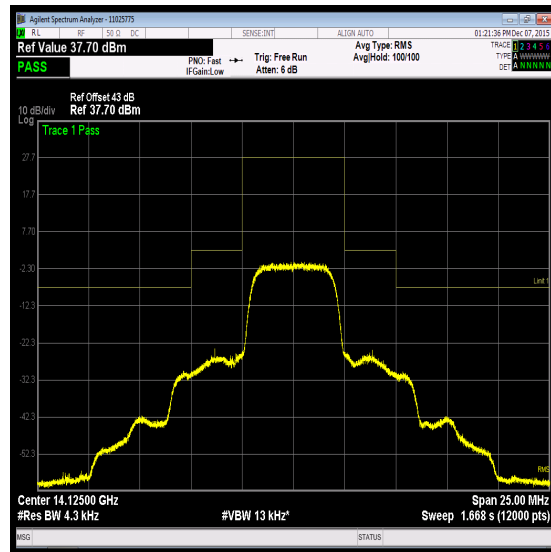

Middle Channel

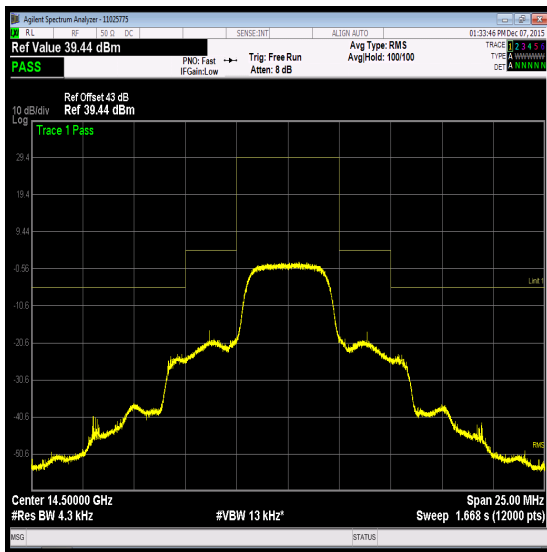

Top Channel

Transmitter Conducted Emissions Masks (continued)

Results: 5 MHz / SF128 / Horizontal

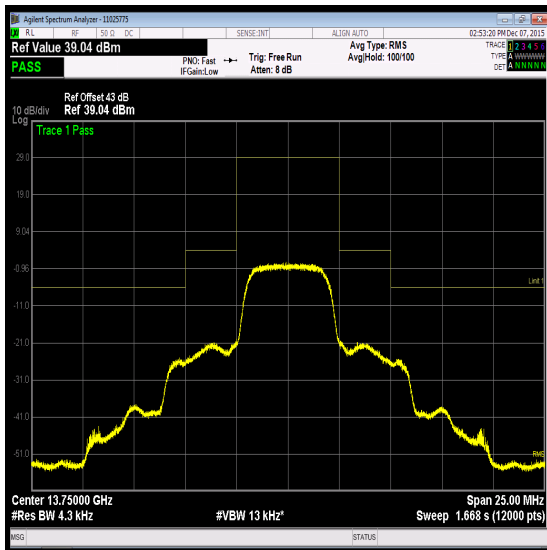

Bottom Channel

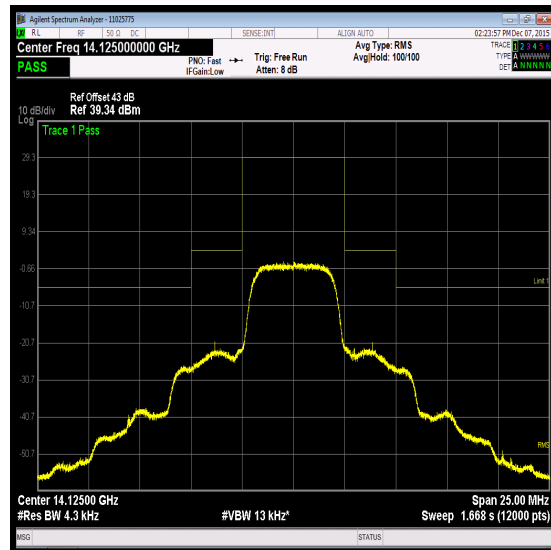

Middle Channel

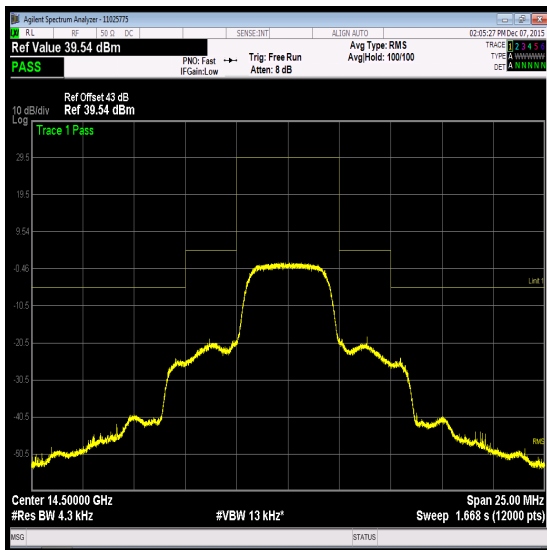

Top Channel

Transmitter Conducted Emissions Masks (continued)

Results: 5 MHz / SF64 / Vertical

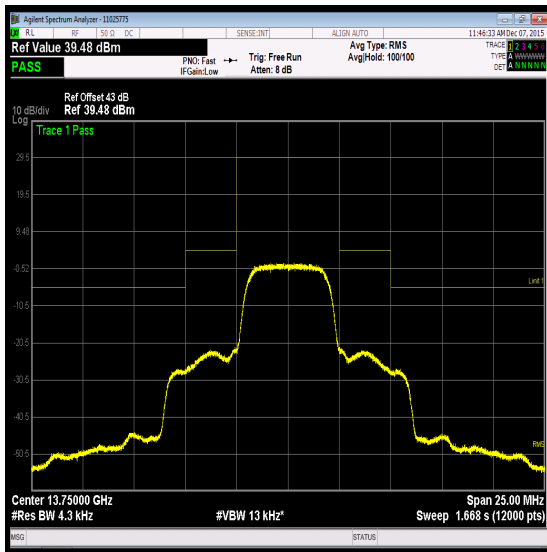

Bottom Channel

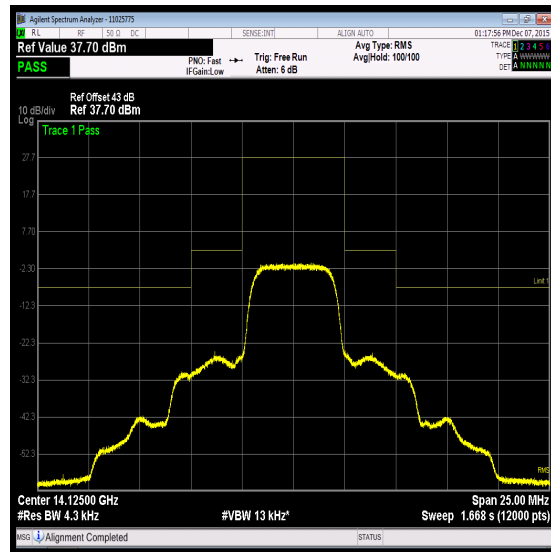

Middle Channel

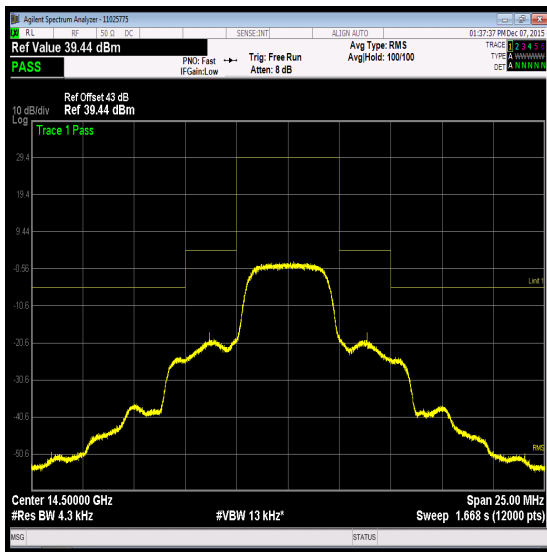

Top Channel

Transmitter Conducted Emissions Masks (continued)

Results: 5 MHz / SF64 / Horizontal

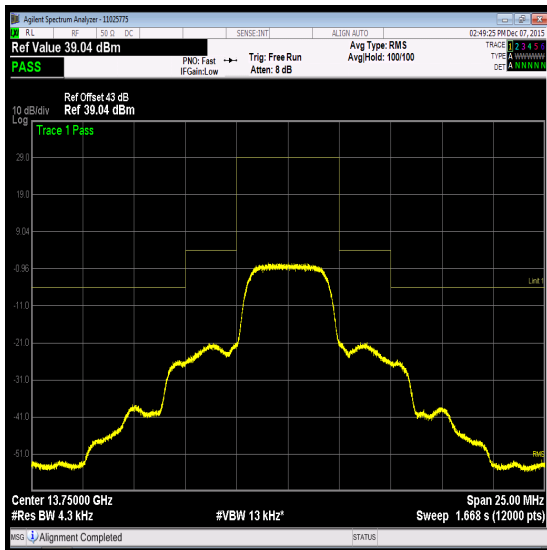

Bottom Channel

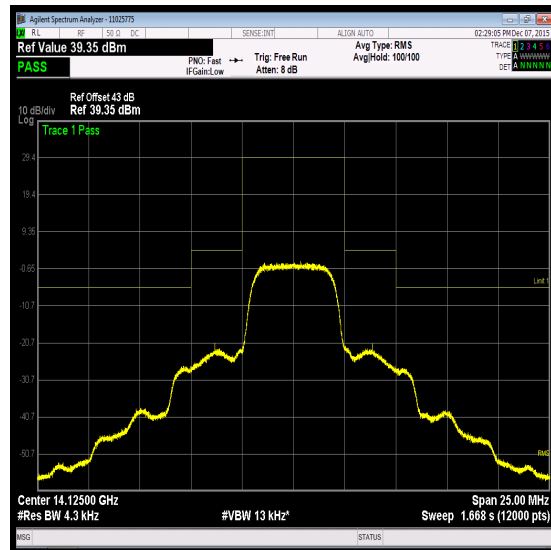

Middle Channel

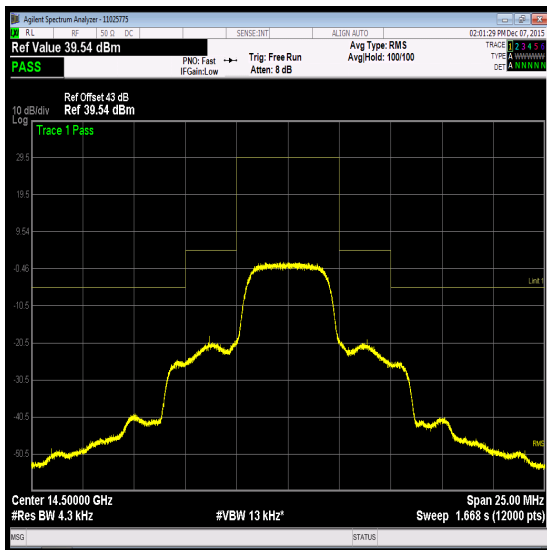

Top Channel

Transmitter Conducted Emissions Masks (continued)

Results: 5 MHz / SF32 / Vertical

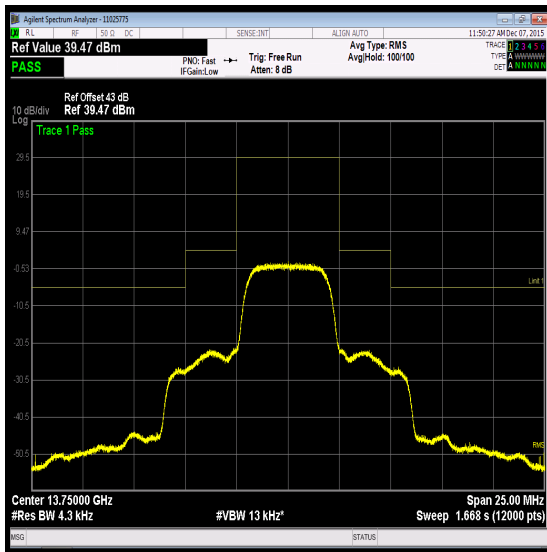

Bottom Channel

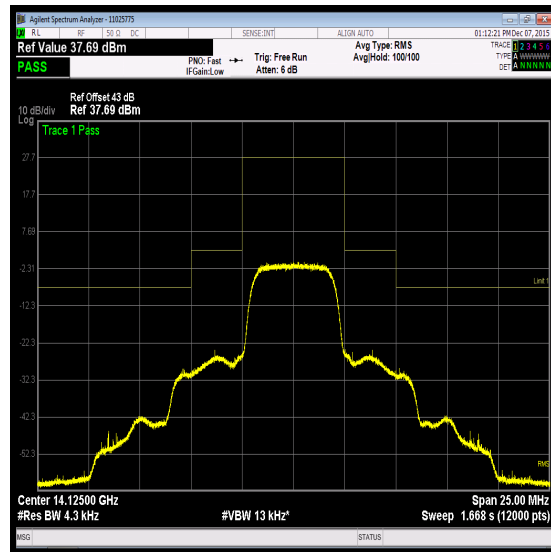

Middle Channel

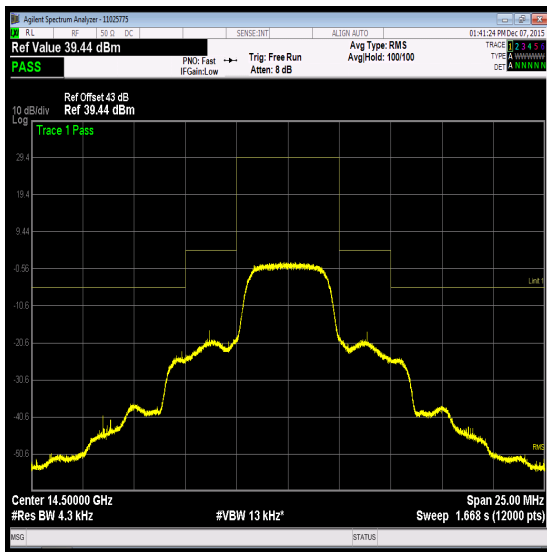

Top Channel

Transmitter Conducted Emissions Masks (continued)

Results: 5 MHz / SF32 / Horizontal

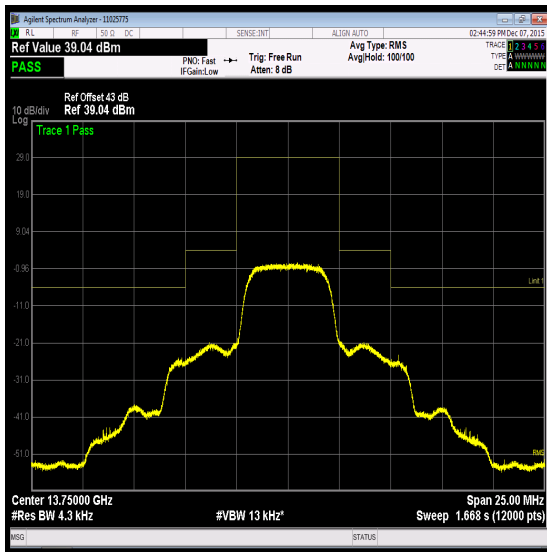

Bottom Channel

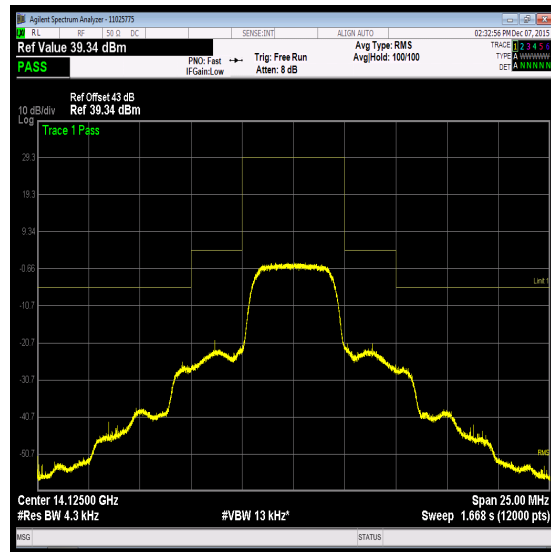

Middle Channel

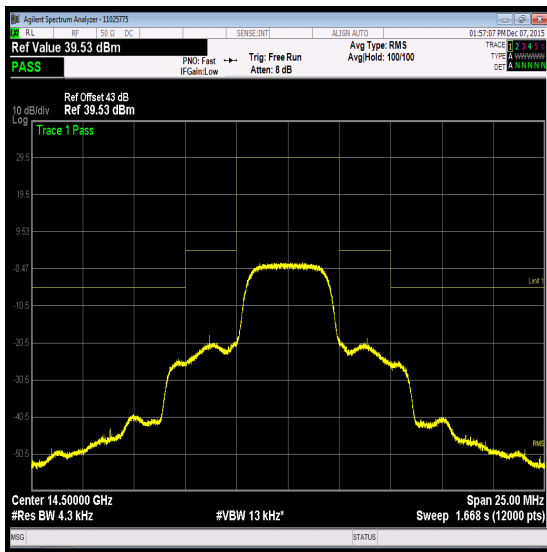

Top Channel

Transmitter Conducted Emissions Masks (continued)

Results: 5 MHz / SF16 / Vertical

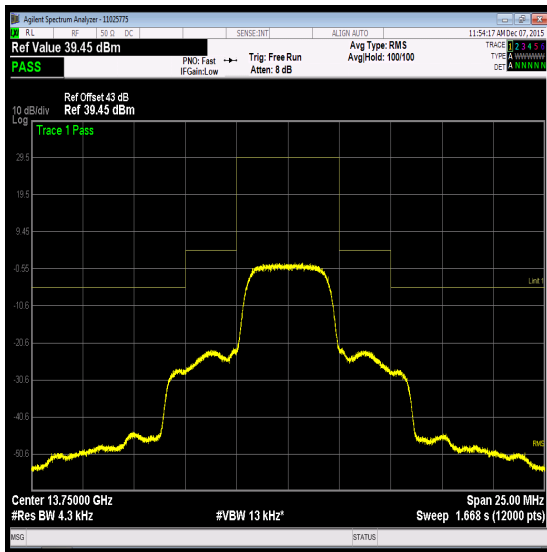

Bottom Channel

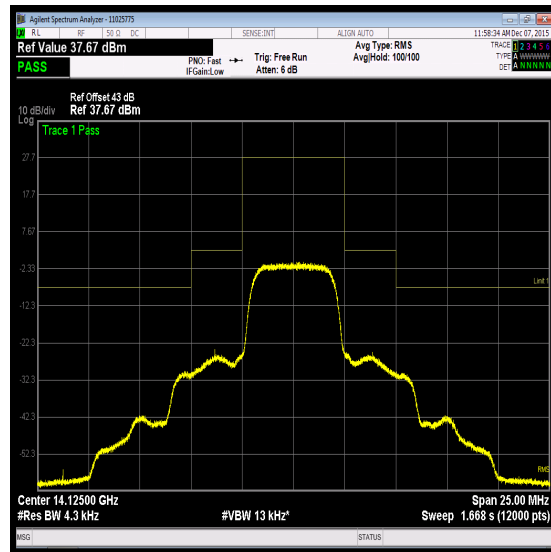

Middle Channel

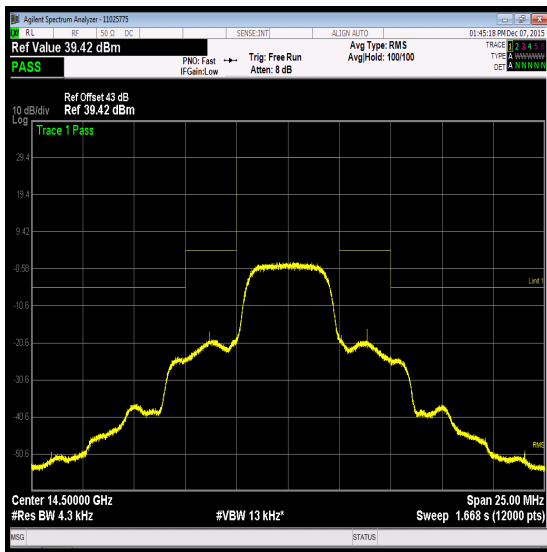

Top Channel

Transmitter Conducted Emissions Masks (continued)

Results: 5 MHz / SF16 / Horizontal

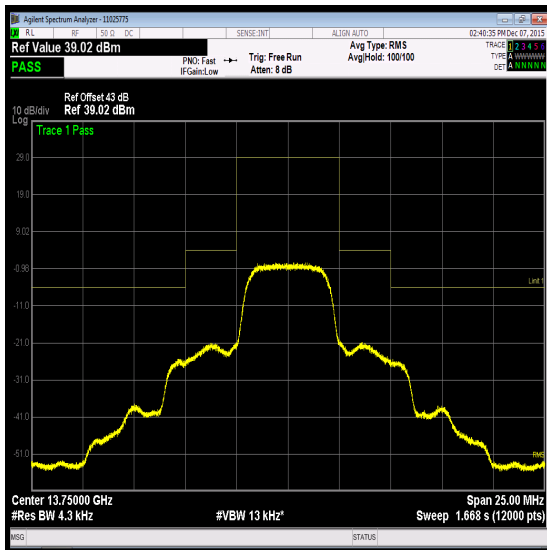

Bottom Channel

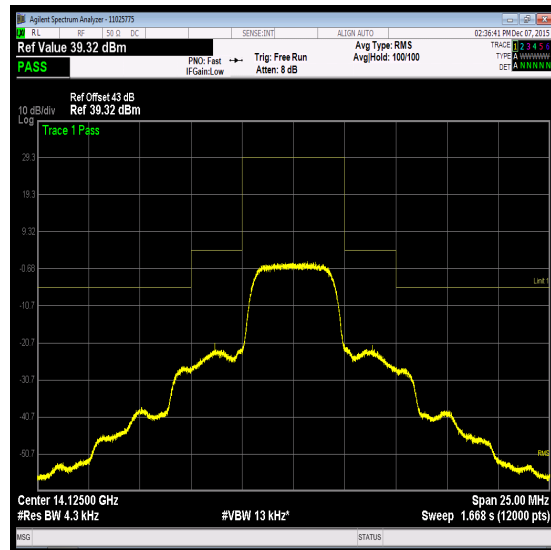

Middle Channel

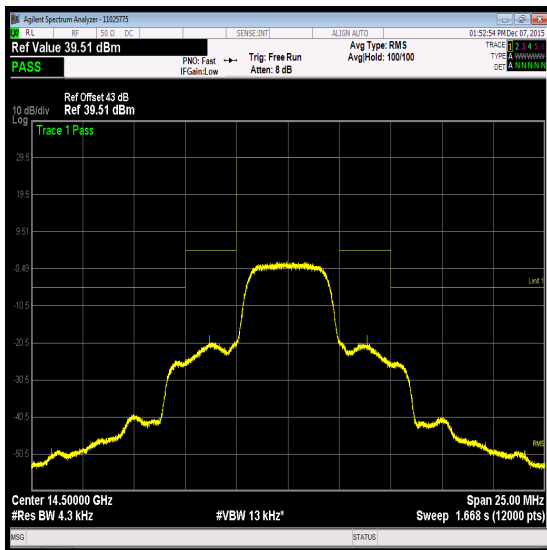

Top Channel

Transmitter Conducted Emissions Masks (continued)

Results: 10 MHz / SF256 / Vertical

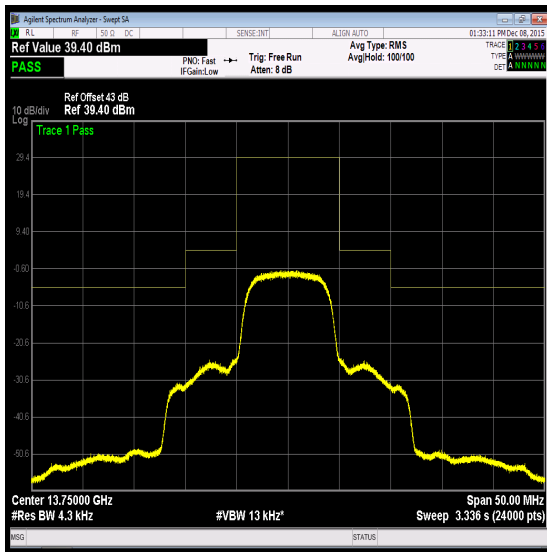

Bottom Channel

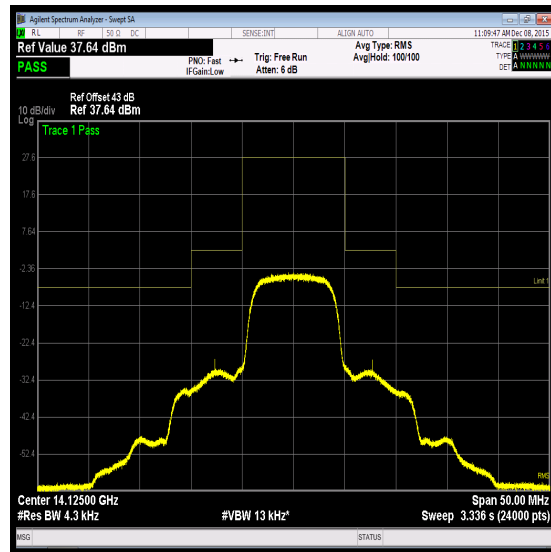

Middle Channel

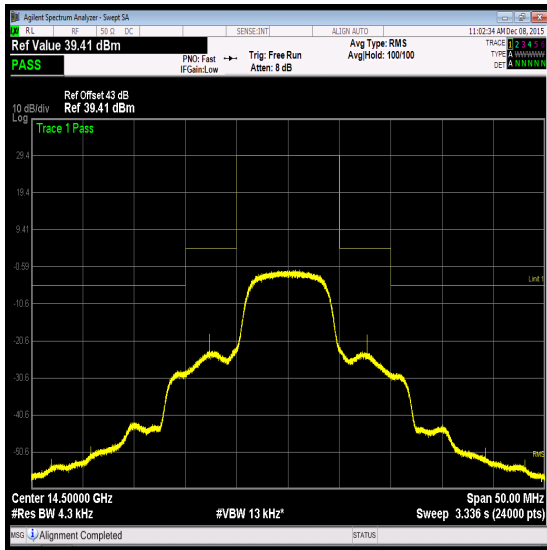

Top Channel