<i>Project/Product/Process</i>	<i>Author</i>	<i>Project/product and doc ID</i>	<i>Pages</i>	<i>Publish Date</i>
Project: 1032	Salah Alazawi	103250101	11	2020-10-05
<i>Title</i>	<i>Distribution</i>	<i>Document Class</i>	<i>Template Rev</i>	<i>Revision & Status</i>
User Manual	Actia Group	VC - Version Controlled	1.1	1 .2 Released

103250101

User Manual



1 CONTENTS

2	Introduction.....	3
2.1	Revision history	3
2.2	Abbreviations.....	3
2.3	References.....	3
3	Overview.....	4
3.1	Connectors.....	4
3.1.1	8-pin MQS connector.....	4
3.1.2	GNSS Antenna.....	4
3.1.3	Cellular Antenna	4
3.1.4	6-pin MQS connector.....	4
3.2	Power Supply	5
3.3	SIM interface	5
3.4	External antenna	5
3.5	RF parameters	5
3.5.1	Supported bands and output power	5
3.6	GNSS	6
3.6.1	Supported bands	6
4	Mechanical design.....	7
5	Functional Description.....	8
6	Installation and maintenance.....	9
6.1	Installation.....	9
6.2	Maintenance.....	9
7	Regulatory Certifications.....	10
7.1	USA (FCC).....	10
7.1.1	FCC Warnings and Notices.....	10
7.1.2	OEM Requirements	11

2 INTRODUCTION

This document describes how to set up the 103250101 for certification testing.

2.1 REVISION HISTORY

Revision	Date	Author(s)	Cause of changes	Updates
1.0	2018-11-28	Salah Alazawi	Release	First release
1.1	2019-09-26	Salah Alazawi	LTE bands correction, safety warning added	Second release

2.2 ABBREVIATIONS

Abbreviation	Meaning
GNSS	Global Navigation Satellite System
QZSS	Quasi-Zenith Satellite System
OTA	Over The Air
CAN	Controller Area Network

2.3 REFERENCES

Reference	Title	Doc. number	Revision

3 OVERVIEW

3.1 CONNECTORS

Following connectors are available on the 103250101:

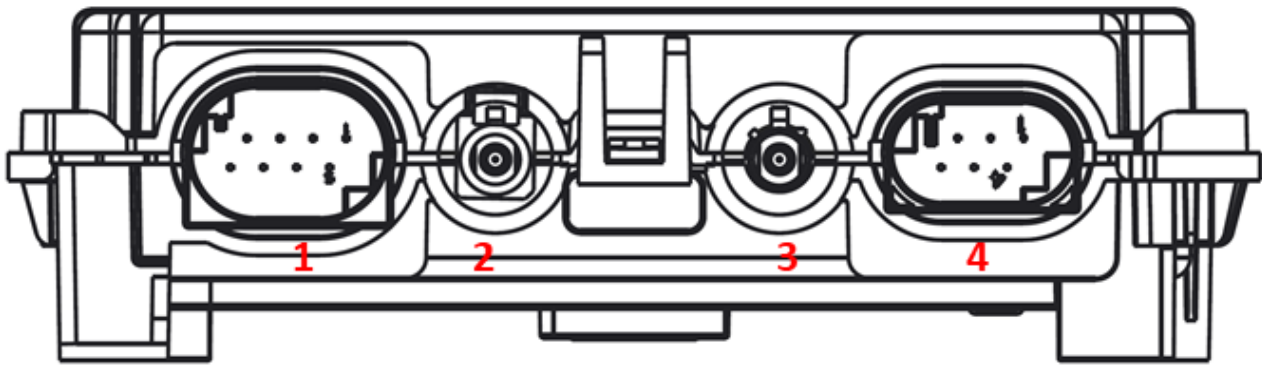

Figure 1 103250101 connectors

103250101 has four external connectors:

1. 8-pin connector Power supply, CAN and I/O.
2. Blue FAKRA Antenna connection for GNSS antenna.
3. Violet FAKRA Antenna connection for main LTE antenna.
4. 6-pin connector Analog inputs. Also test interface is available after modification of unit.

3.1.1 8-pin MQS connector

This connector is used for power supply, CAN bus, input- and output signals.

3.1.2 GNSS Antenna

The blue FAKRA connector is input for GNSS antenna.

3.1.3 Cellular Antenna

The violet FAKRA is the main antenna interface for 2G/3G/4G communication.

3.1.4 6-pin MQS connector

This connector is used for input signals.

3.2 POWER SUPPLY

The 103250101 is designed to be powered by an external vehicle battery. Nominal supply voltages are 12, 24, 36, 48 V (depending on vehicle). The power supply range is 8-60V.

3.3 SIM INTERFACE

The embedded modem can use an embedded SIM chip as a SIM source.

3.4 EXTERNAL ANTENNA

103250101 is certified to be used with an external roof mounted antenna.

3.5 RF PARAMETERS

3.5.1 Supported bands and output power

Mode	Band	Frequency (MHz)		Max. Tx power(dBm)
		Rx	Tx	
GSM/GPRS/EDGE	850	869 – 894	824 – 849	+33
	900	925 – 960	880 – 915	
	1800	1805 – 1880	1710 – 1785	+30
	1900	1930 – 1990	1850 – 1910	
WCDMA/HSPA	I (2100)	2110 – 2170	1920 – 1980	+24
	II (1900)	1930 – 1990	1850 – 1910	
	IV (AWS)	2110 – 2155	1710 – 1755	
	V (850)	869 – 894	824 – 849	
	VIII (900)	925 – 960	880 – 915	
	IX (1800)	1845 – 1880	1750 – 1785	
	XIX (800)	875 – 890	830 – 845	
LTE FDD	Bd 1 (2100)	2110 – 2170	1920 – 1980	+23
	Bd 2 (1900)	1930 – 1990	1850 – 1910	
	Bd 3 (1800)	1805 – 1880	1710 – 1785	
	Bd 4 (AWS)	2110 – 2155	1710 – 1755	
	Bd 5 (850)	869-894	824-849	

	Bd 7 (2600)	2620 – 2690	2500 – 2570	
	Bd 8 (900)	925 – 960	880 – 915	
	Bd 12 (700)	729 – 746	699 – 716	
	Bd 18 (800)	860 – 875	815 – 830	
	Bd 19 (800)	875 – 890	830 – 845	
	Bd 20 (800)	791 – 821	832 – 862	
	Bd 28 (700)	758 – 803	703 – 748	

3.6 GNSS

GNSS antenna input is the blue FAKRA connector.

3.6.1 Supported bands

Technology	Bands
GPS	L1
GLONASS	L1 FDMA
Galileo	E1
BeiDou (COMPAS)	B1, B1-2
QZSS	L1

4 MECHANICAL DESIGN

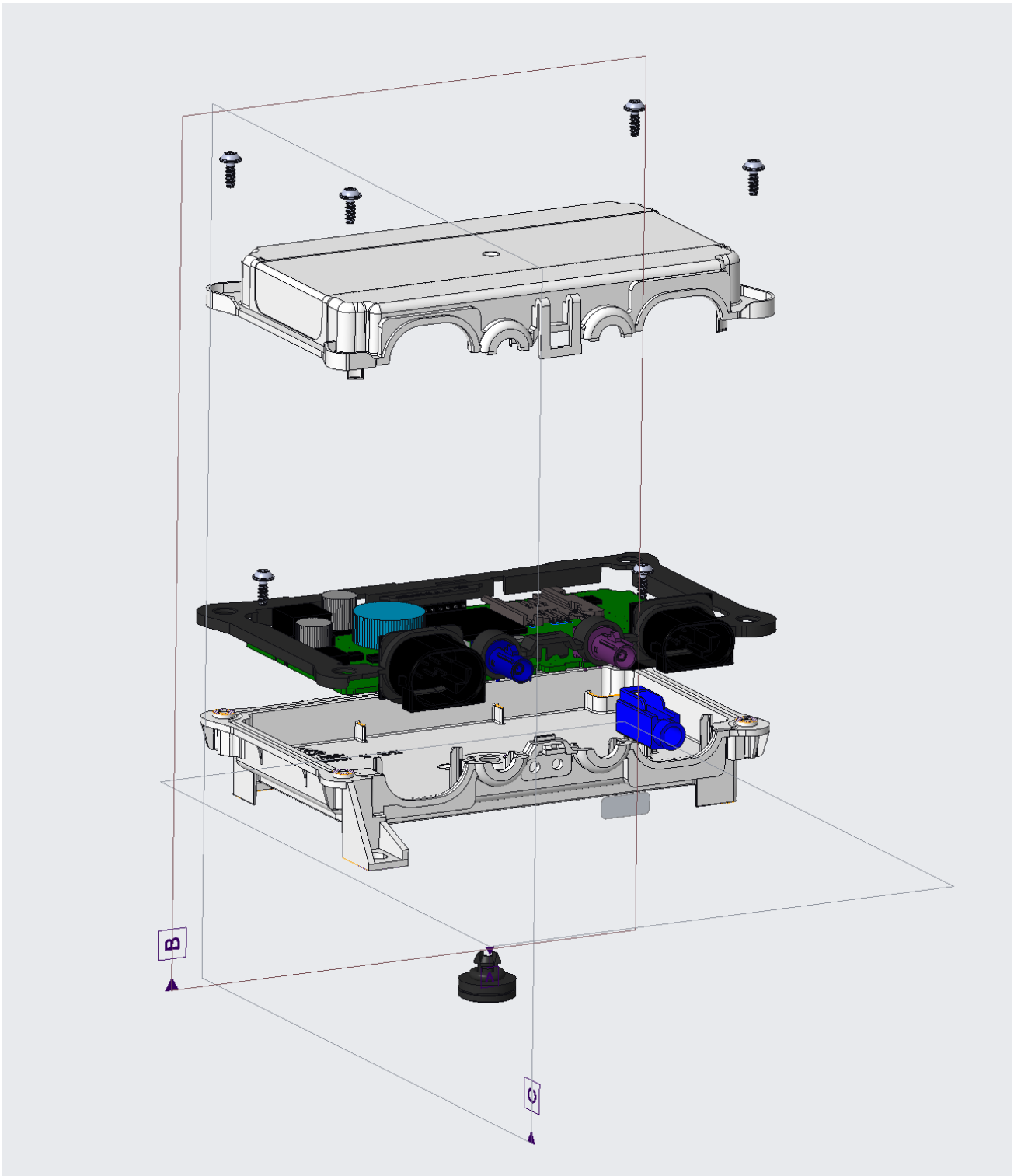

Figure 2 103250101 mechanical design

5 FUNCTIONAL DESCRIPTION

The following functions are available in the 103250101:

- Allow log on and start a working pass. In some cases, the driver will need to perform a Pre-Operational check by answering questions that are handled by the 103250101 before starting the working pass.
- Gather information and send various reports from the truck including truck status, battery data, working pass data, collision reports etc. to the manufacturer server.
- Send configurations to the 103250101 for setting of the various options.
- Send truck immobilize command.
- Retrieve diagnostic data using the TruckCom diagnostics tool.
- Update software over CAN or OTA.
- Gather GNSS data and get geofencing notifications.
- Report issues with the truck.
- Immobilize the truck when it has received a shock (crash).

6 INSTALLATION AND MAINTENANCE

6.1 INSTALLATION

The product is factory fitted in trucks. It is not possible to buy this product separately.

Please be aware that the antenna must be installed to provide a separation distance of at least 20cm from all persons.

6.2 MAINTENANCE

The status of the product can be read via diagnostic connections using special workshop tools. In addition, other ECUs monitor the communication from the product and in case of missing/invalid communication, the Central Electronic Module in the truck is alerted, and will display a warning to the driver.

Maintenance and replacement of the product can only be performed by certified workshops.

7 REGULATORY CERTIFICATIONS

7.1 USA (FCC)

This device complies with Part 15 of the FCC rules. Operation is subject to the following two conditions:

- (1) This device may not cause harmful interference, and
- (2) This device must accept any interference received, including interference that may cause undesired operation.

7.1.1 FCC Warnings and Notices

WARNING: The FCC requires the user to be notified that any changes or modifications made to this device that are not expressly approved by Actia Nordic AB could void the user's authority to operate the equipment.

RF EXPOSURE WARNING: This equipment complies with FCC radiation exposure limits set forth for an uncontrolled environment. This equipment should be installed and operated with minimum distance 20 cm between the radiator and your body. This transmitter must not be collocated or operating in conjunction with any other antenna or transmitter.

NOTICE: This equipment has been tested and found to comply with the limits for a Class B digital device, pursuant to part 15 of the FCC Rules. These limits are designed to provide reasonable protection against harmful interference in a residential installation. This equipment generates, uses, and can radiate radio frequency energy and, if not installed and used in accordance with the instructions, may cause harmful interference to radio communications. However, there is no guarantee that interference will not occur in a particular installation. If this equipment does cause harmful interference to radio or television reception, which can be determined by turning the equipment off and on, the user is encouraged to try to correct the interference by one or more of the following measures:

- Reorient or relocate the receiving antenna. - Increase the separation between the equipment and receiver.
- Connect the equipment into an outlet on a circuit different from that to which the receiver is connected.
- Consult the dealer or an experienced radio/TV technician for help.

7.1.2 OEM Requirements

Following text should be printed in the user manual for vehicles in US:

Type Approval USA

FCC ID: 2AGKK103250101

This device complies with Part 15 of the FCC rules. Operation is subject to the following two conditions:

- (1) This device may not cause harmful interference, and
- (2) (2) This device must accept any interference received, including interference that may cause undesired operation.

WARNING: Changes or modifications not expressly approved by the party responsible for compliance could void the user's authority to operate the equipment.