



FCC SAR TEST REPORT

Report No: STS1603171H01

Issued for

Prodrone Technology (Shenzhen) Co., Ltd

**8th Floor, Beike Building, South High Technology
Park, Nanshan District, Shenzhen**

Product Name:	Prodrone byrd
Brand Name:	Prodrone
Model No.:	CME01-M2
FCC ID:	2AGKH-PD-RC01-0103
Series Model:	N/A
Test Standard:	ANSI/IEEE Std. C95.1
	FCC 47 CFR Part 2 (2.1093)
	IEEE 1528: 2013
Max. SAR (1g)	Body: 0.846 W/kg
Max. SAR (10g):	Limb-worn: 0.493 W/kg
Max. Simultaneous SAR	Limb-worn: 0.892 W/kg
	Body: 1.504 W/kg

Any reproduction of this document must be done in full. No single part of this document may be reproduced without permission from STS, All Test Data Presented in this report is only applicable to presented Test sample.

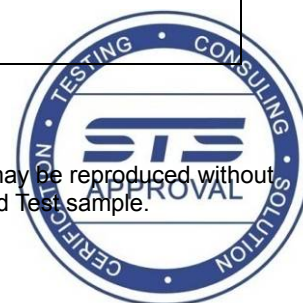



Test Report Certification

Applicant's name : Prodrone Technology (Shenzhen) Co., Ltd
Address : 8th Floor, Beike Building, South High Technology Park, Nanshan District, Shenzhen
Manufacture's Name : Prodrone Technology (Shenzhen) Co., Ltd
Address : 8th Floor, Beike Building, South High Technology Park, Nanshan District, Shenzhen

Product description

Product name : Prodrone byrd
Trademark : Prodrone
Model and/or type reference : CME01-M2
Serial Model : N/A

Standards : ANSI/IEEE Std. C95.1-1992
 FCC 47 CFR Part 2 (2.1093)
 IEEE 1528: 2013

The device was tested by Shenzhen STS Test Services Co., Ltd. in accordance with the measurement methods and procedures specified in KDB 865664 The test results in this report apply only to the tested sample of the stated device/equipment. Other similar device/equipment will not necessarily produce the same results due to production tolerance and measurement uncertainties.

Date of Test :
Date (s) of performance of tests : 05 Apr. 2016
Date of Issue : 24 May. 2016
Test Result : **Pass**

Testing Engineer :

Allen Chen

(Allen Chen)

Technical Manager :

John Zou

(John Zou)

Authorized Signatory :

Bovey Yang

(Bovey Yang)





TABLE OF CONTENTS

1. General Information	4
1.1 EUT Description	4
1.2 Test Environment	5
1.3 Test Facility	5
2. Test Standards and Limits	6
3. SAR Measurement System	7
3.1 Definition Of Specific Absorption Rate (SAR)	7
3.2 SAR System	7
3.2.1 Probe	8
3.2.2 Phantom	9
3.2.3 Device Holder	9
4. Tissue Simulating Liquids	10
4.1 Simulating Liquids Parameter Check	10
5. SAR System Validation	12
5.1 Validation System	12
5.2 Validation Result	12
6. SAR Evaluation Procedures	13
7. EUT Antenna Location Sketch	14
7.1 SAR TEST EXCLUSION CONSIDER TABLE	14
8. EUT Test Position	16
8.1 Define Two Imaginary Lines On The Handset	16
9. Uncertainty	17
9.1 Measurement Uncertainty	17
9.2 System validation Uncertainty	19
10. Conducted Power Measurement	21
10.2 Turn Power	21
11. EUT and Test Setup Photo	22
11.1 EUT Photo	22
11.2 Setup Photo	26
12. SAR Result Summary	29
13. Equipment List	31
Appendix A. System Validation Plots	32
System Performance Check Data(5800MHz Body)	34
Appendix B. SAR Test Plots	36
Appendix C. Probe Calibration And Dipole Calibration Report	40

1. General Information

Environmental evaluation measurements of specific absorption rate (SAR) distributions in emulated human body tissues exposed to radio frequency (RF) radiation from wireless portable devices for compliance with the rules and regulations of the U.S. Federal Communications Commission (FCC).

1.1 EUT Description

Equipment	Prodrone byrd
Brand Name	Prodrone
Model No.	CME01-M2
Serial Model	N/A
Model Difference	N/A
Adapter	Input: AC100-240V, 1.5 A, 50/60 Hz Output: DC 16.8V, 4000mA
Battery	Rated Voltage: 3.7V Charge Limit: 4.25V Capacity :2500mAh
Hardware Version	N/A
Software Version	N/A
Frequency Range	2.4G: 2412 MHz ~ 2462 MHz 5.8G: 5745 MHz ~ 5810 MHz
Max. Reported SAR(1g):	Body: 2.4G: 0.658 W/kg 5.8G: 0.846 W/kg
Max. Reported SAR(10g):	Limb-worn : 2.4G: 0.399 W/kg 5.8G: 0.493 W/kg
Max. Simultaneous SAR(1g):	Body: 1.504 W/kg
Max. Simultaneous SAR(10g):	Limb-worn : 0.892 W/kg
Operating Mode:	2.4G: WI-FI IEEE 802.11b/g/n 5.8G:SRD
Antenna Specification:	2.4G: Ceramic Antenna 5.8G: Dipole Antenna
Hotspot Mode:	Not Support
DTM Mode:	Not Support



1.2 Test Environment

Ambient conditions in the SAR laboratory:

Items	Required	Actual
Temperature (°C)	18-25	22~23
Humidity (%RH)	30-70	55~65

1.3 Test Facility

Shenzhen STS Test Services Co., Ltd.

Add. : 1/F, Building B, Zhuoke Science Park, No.190, Chongqing Road, Fuyong, Baoan District, Shenzhen, Guangdong, China

CNAS Registration No.: L7649

FCC Registration No.: 842334;

IC Registration No.: 12108A-1



2. Test Standards and Limits

No.	Identity	Document Title
1	47 CFR Part 2	Frequency Allocations and Radio Treaty Matters; General Rules and Regulations
2	ANSI/IEEE Std. C95.1-1992	IEEE Standard for Safety Levels with Respect to Human Exposure to Radio Frequency Electromagnetic Fields, 3 kHz to 300 GHz
3	IEEE Std. 1528-2013	Recommended Practice for Determining the Peak Spatial-Average Specific Absorption Rate (SAR) in the Human Head from Wireless Communications Devices: Measurement Techniques
4	FCC KDB 447498 D01 v06	Mobile and Portable Device RF Exposure Procedures and Equipment Authorization Policies
5	FCC KDB 865664 D01 v01r04	SAR Measurement 100 MHz to 6 GHz
6	FCC KDB 865664 D02 v01r02	RF Exposure Reporting
7	FCC KDB 248227 D01 Wi-Fi SAR v02r02	SAR Considerations for 802.11 Devices
8	FCC KDB 941225 D07 UMPC Mini Tablet v01r02	SAR EVALUATION PROCEDURES FOR UMPC MINI-TABLET DEVICES

(A). Limits for Occupational/Controlled Exposure (W/kg)

<u>Whole-Body</u>	<u>Partial-Body</u>	<u>Hands, Wrists, Feet and Ankles</u>
0.4	8.0	20.0

(B). Limits for General Population/Uncontrolled Exposure (W/kg)

<u>Whole-Body</u>	<u>Partial-Body</u>	<u>Hands, Wrists, Feet and Ankles</u>
0.08	1.6	4.0

NOTE: Whole-Body SAR is averaged over the entire body, partial-body SAR is averaged over any 1 gram of tissue defined as a tissue volume in the shape of a cube. SAR for hands, wrists, feet and ankles is averaged over any 10 grams of tissue defined as a tissue volume in the shape of a cube.

Population/Uncontrolled Environments:

are defined as locations where there is the exposure of individuals who have no knowledge or control of their exposure.

Occupational/Controlled Environments:

are defined as locations where there is exposure that may be incurred by people who are aware of the potential for exposure, (i.e. as a result of employment or occupation).

NOTE
GENERAL POPULATION/UNCONTROLLED EXPOSURE
Hands, Wrists, Feet and Ankles LIMIT 4.0 W/kg;
BODY LIMIT 1.6 W/kg.

3. SAR Measurement System

3.1 Definition Of Specific Absorption Rate (SAR)

SAR is related to the rate at which energy is absorbed per unit mass in an object exposed to a radio field. The SAR distribution in a biological body is complicated and is usually carried out by experimental techniques or numerical modeling. The standard recommends limits for two tiers of groups, occupational/controlled and general population/uncontrolled, based on a person's awareness and ability to exercise control over his or her exposure. In general, occupational/controlled exposure limits are higher than the limits for general population/uncontrolled.

The SAR definition is the time derivative (rate) of the incremental energy (dW) absorbed by (dissipated in) an incremental mass (dm) contained in a volume element (dv) of a given density (ρ). The equation description is as below:

$$SAR = \frac{d}{dt} \left(\frac{dW}{dm} \right) = \frac{d}{dt} \left(\frac{dW}{\rho dv} \right)$$

SAR is expressed in units of Watts per kilogram (W/kg) SAR measurement can be related to the electrical field in the tissue by

$$SAR = \frac{\sigma E^2}{\rho}$$

Where: σ is the conductivity of the tissue,
ρ is the mass density of the tissue and E is the RMS electrical field strength.

3.2 SAR System

SATIMO SAR System Diagram:

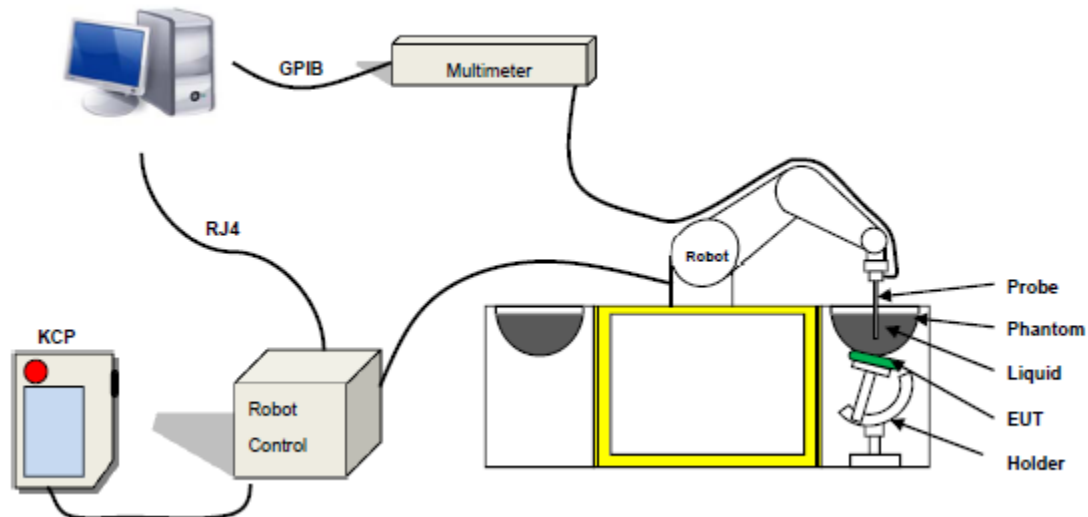

Comosar is a system that is able to determine the SAR distribution inside a phantom of human being according to different standards. The Comosar system consists of the following items:

- Main computer to control all the system
- 6 axis robot
- Data acquisition system
- Miniature E-field probe
- Phone holder
- Head simulating tissue

The following figure shows the system.



The EUT under test operating at the maximum power level is placed in the phone holder, under the phantom, which is filled with head simulating liquid. The E-Field probe measures the electric field inside the phantom. The OpenSAR software computes the results to give a SAR value in a 1g or 10g mass.

3.2.1 Probe

For the measurements the Specific Dosimetric E-Field Probe SN 45/15 EPGO281 with following specifications is used

- Dynamic range: 0.01-100 W/kg
- Tip Diameter: 2.5 mm
- Length of Individual Dipoles: 2 mm
- Maximum external diameter: 8 mm
- Distance between dipole/probe extremity: 8 mm

(repeatability better than +/- 1mm)

- Probe linearity: $0 \pm 2.60\%$ (0.11dB)
- Axial Isotropy: < 0.25 dB

- Spherical Isotropy: < 0.25 dB

- Calibration range: 450 MHz to 6 GHz for head & body simulating liquid.

Angle between probe axis (evaluation axis) and surface normal line: less than 30°



Figure-MVG COMOSAR Dosimetric E field Dipole

3.2.2 Phantom

For the measurements the Specific Anthropomorphic Mannequin (SAM) defined by the IEEE SCC-34/SC2 group is used. The phantom is a polyurethane shell integrated in a wooden table. The thickness of the phantom amounts to 2mm +/- 0.2mm. It enables the dosimetric evaluation of left and right phone usage and includes an additional flat phantom part for the simplified performance check. The phantom set-up includes a cover, which prevents the evaporation of the liquid.

SN 32/14 SAM115



SN 32/14 SAM116



3.2.3 Device Holder

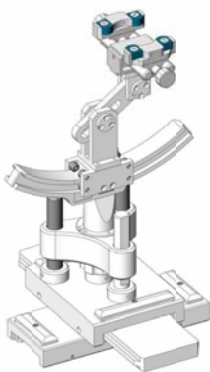

The SAR in the phantom is approximately inversely proportional to the square of the distance between the source and the liquid surface. For a source at 5 mm distance, a positioning uncertainty of ± 0.5 mm would produce a SAR uncertainty of ± 20 %. Accurate device positioning is therefore crucial for accurate and repeatable measurements. The positions in which the devices must be measured are defined by the standards.

4. Tissue Simulating Liquids

4.1 Simulating Liquids Parameter Check

The head tissue dielectric parameters recommended by the IEEE SCC-34/SC-2 in P1528 have been incorporated in the following table. These head parameters are derived from planar layer models simulating the highest expected SAR for the dielectric properties and tissue thickness variations in a human head. Other head and body tissue parameters that have not been specified in P1528 are derived from the tissue dielectric parameters computed from the 4-Cole-Cole equations described in Reference [12] and extrapolated according to the head parameters specified in P1528.

Frequency (MHz)	Triton X-100	DGBE	HEC	NaCl	Sucrose	1,2-Propanediol	Water	Conductivity	Permittivity
	%	%	%	%	%	%	%	σ	ϵ_r
835	/	/	/	0.79	/	64.81	34.40	0.97	41.8
900	/	/	/	0.79	/	64.81	34.40	0.97	41.8
1800	30.45	13.84	/	0.35	/	/	55.36	1.38	41.0
1900	30.45	13.84	/	0.35	/	/	55.36	1.38	41.0
2100	19.97	7.99	/	0.16	/	/	71.88	1.55	41.1
2450	/	7.99	/	0.16	/	/	50.0	1.88	40.3
5800	17.24	17.24	/	/	/	/	65.53	5.29	35.2

Tissue dielectric parameters for head and body phantoms				
Frequency	ϵ_r		σ S/m	
	Head	Body	Head	Body
300	45.3	58.2	0.87	0.92
450	43.5	58.7	0.87	0.94
900	41.5	55.0	0.97	1.05
1450	40.5	54.0	1.20	1.30
1800	40.0	53.3	1.40	1.52
2450	39.2	52.7	1.80	1.95
3000	38.5	52.0	2.40	2.73
5800	35.3	48.2	5.27	6.00

**LIQUID MEASUREMENT RESULTS**

Date: Apr.05, 2016

Ambient condition: Temperature 22.0°C Relative humidity: 49%

Body Simulating Liquid		Parameters	Target	Measured	Deviation[%]	Limited[%]
Frequency	Temp. [°C]					
2450 MHz	21.5	Permittivity:	52.7	52.41	-0.55	± 5
		Conductivity:	1.95	1.93	-1.03	± 5
5800 MHz	21.5	Permittivity:	48.2	47.6	-1.24	± 5
		Conductivity:	6.00	5.72	-4.67	± 5



5. SAR System Validation

5.1 Validation System

Each SATIMO system is equipped with one or more system validation kits. These units, together with the predefined measurement procedures within the SATIMO software, enable the user to conduct the system performance check and system validation. System kit includes a dipole, and dipole device holder.

The system check verifies that the system operates within its specifications. It's performed daily or before every SAR measurement. The system check uses normal SAR measurement in the flat section of the phantom with a matched dipole at a specified distance. The system validation setup is shown as below.

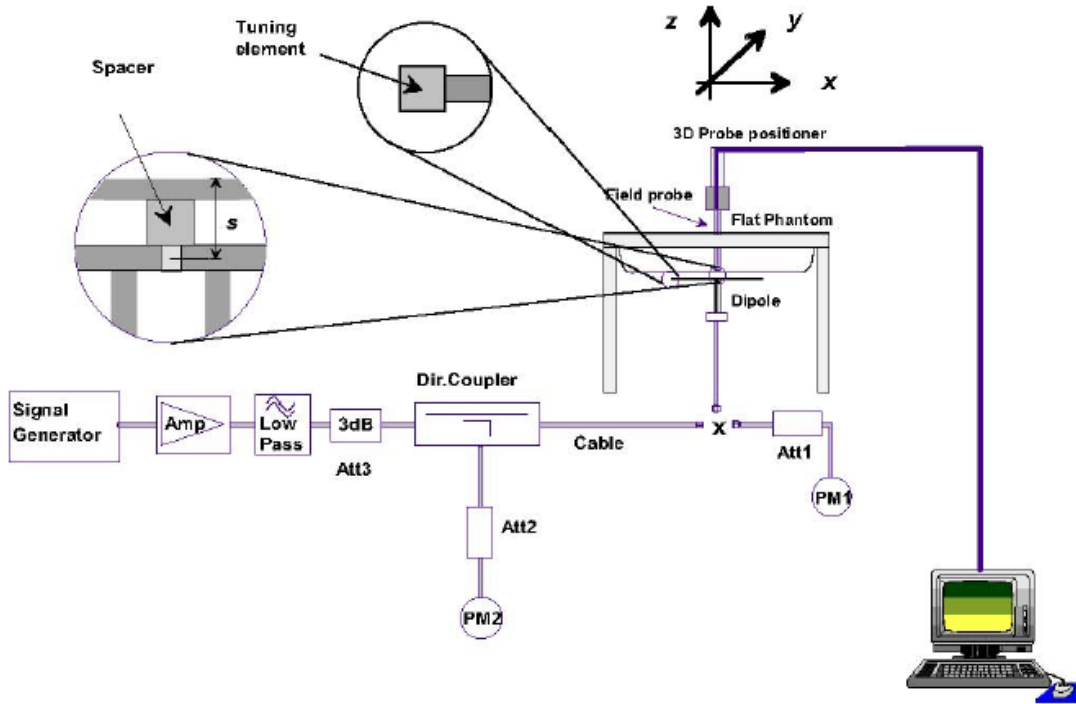

5.2 Validation Result

Comparing to the original SAR value provided by SATIMO, the validation data should be within its specification of 10 %.

Ambient condition: Temperature 22.7°C **Relative humidity:** 49%

Freq.(MHz)	Power(mW)	Tested Value (W/Kg)	Normalized SAR (W/kg)	Target(W/Kg)	Tolerance(%)	Date
2450 Body	100	5.108	51.08	55.65	-8.21	2016-04-05
5800 Body	100	18.578	185.78	183.06	1.49	2016-04-05

Note: The tolerance limit of System validation $\pm 10\%$.

6. SAR Evaluation Procedures

The procedure for assessing the average SAR value consists of the following steps:

The following steps are used for each test position

- Establish a call with the maximum output power with a base station simulator. The connection between the mobile and the base station simulator is established via air interface
- Measurement of the local E-field value at a fixed location. This value serves as a reference value for calculating a possible power drift.
- Measurement of the SAR distribution with a grid of 8 to 16mm * 8 to 16 mm and a constant distance to the inner surface of the phantom. Since the sensors cannot directly measure at the inner phantom surface, the values between the sensors and the inner phantom surface are extrapolated. With these values the area of the maximum SAR is calculated by an interpolation scheme.
- Around this point, a cube of 30 * 30 * 30 mm or 32 * 32 * 32 mm is assessed by measuring 5 or 8 * 5 or 8*4 or 5 mm. With these data, the peak spatial-average SAR value can be calculated.

➤ Area Scan& Zoom Scan

First Area Scan is used to locate the approximate location(s) of the local peak SAR value(s). The measurement grid within an Area Scan is defined by the grid extent, grid step size and grid offset. Next, in order to determine the EM field distribution in a three-dimensional spatial extension, Zoom Scan is required. The Zoom Scan is performed around the highest E-field value to determine the averaged SAR-distribution over 10 g. Area scan and zoom scan resolution setting follows KDB 865664 D01 quoted below.

When the 1-g SAR of the highest peak is within 2 dB of the SAR limit, additional zoom scans are required for other peaks within 2 dB of the highest peak that have not been included in any zoom scan to ensure there is no increase in SAR.

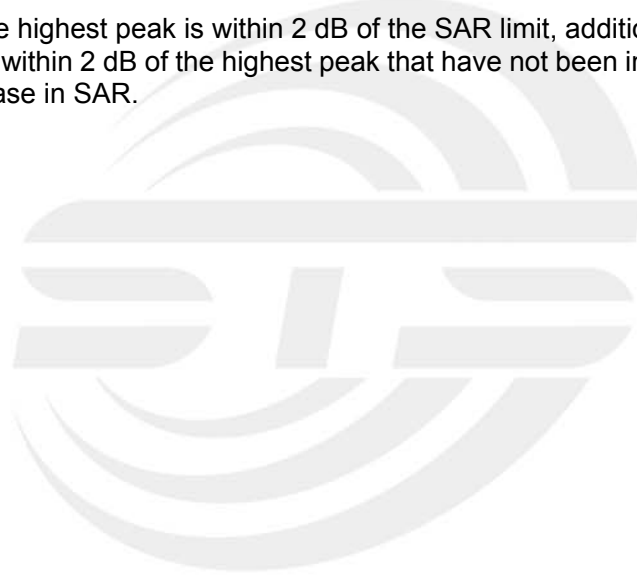

7. EUT Antenna Location Sketch

It is a Prodrone byrd, support 2.4G and 5.8G mode.

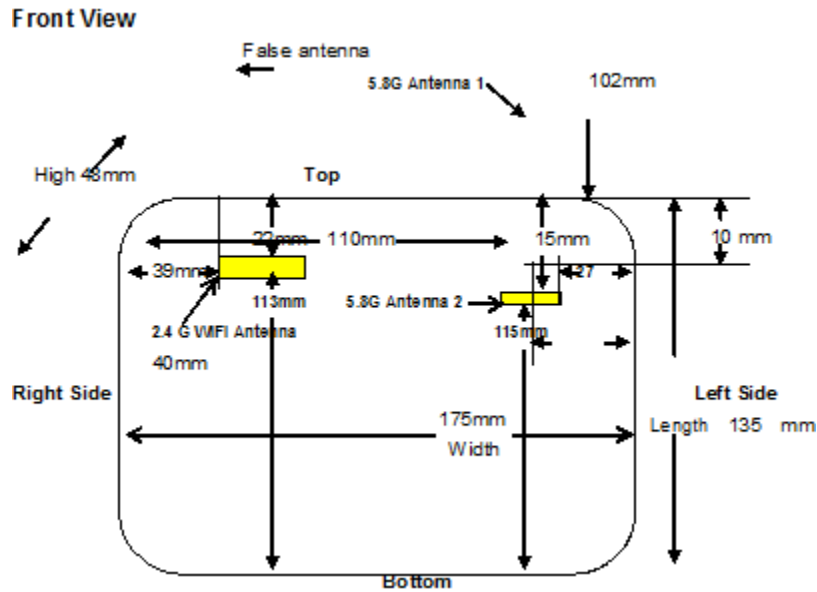

Distance of The Antenna to the EUT surface and edge						
Antennas	Top side	Bottom side	Front Side	Back Side	Left Side	Right Side
2.4 WLAN	22mm	113mm	18mm	20mm	39mm	95mm
5.8G ant1	<5mm	135mm	<5mm	<5mm	110mm	40mm
5.8G ant2	15mm	115mm	<5mm	42mm	115mm	27mm

7.1 SAR TEST EXCLUSION CONSIDER TABLE

The product in normal use, the upper and lower surface does not come into contact with the torso and arms, the front surface outwardly, does not come into contact with the torso and arms, so front, top, bottom without assessment, 5.8GHz antenna 1 because it is external Therefore according to the minimum distance 5mm assessment, but located external dipole antenna prototype front end, is directed forward in normal use, will not come into contact with the torso and arms, so that the antenna used for this evaluation is based on the shortest distance between the antenna and the point of integration of the product (part prototype antenna is located inside) the right surface to calculate the distance prototype, this distance had marked on the map.

Positions for SAR tests						
Antennas	Top side	Bottom side	Front Side	Back Side	Left Side	Right Side
2.4 WLAN	No	No	Yes	Yes	No	No
5.8G ant1	No	No	Yes	Yes	No	No
5.8G ant2	No	No	Yes	Yes	No	No

Note:

1. maximum power is the source-based time-average power and represents the maximum RF output power among production units.
2. Per KDB 447498 D01v06, for larger devices, the test separation distance of adjacent edge configuration is determined by the closest separation between the antenna and the user.
3. per KDB 447498 D01v06, standalone SAR test exclusion threshold is applied; if the distance of the antenna to the user is <5mm, 5mm is user to determine SAR exclusion threshold



4. per KDB 447498 D01v06, the 1-g and 10-g SAR test exclusion thresholds for 100 MHz to 6 GHz at test separation distance ≤ 50 mm are determined by:
[(max.power of channel, including tune-up tolerance, Mw)/ (min. test separation distance, mm)]* [$\sqrt{f(\text{GHz})}$] ≤ 3.0 for 1-g SAR and ≤ 7.5 for 10-g extremity SAR
f(GHz) is the RF channel transmit frequency in GHz
Power and distance are rounded to the nearest mW and mm before calculation
The result is rounded to one decimal place for comparison
For < 50 mm distance, we just calculate mW of the exclusion threshold value(3.0) to do compare
5. per KDB 447498 D01v06, at 100 MHz to 6GHz and for test separation distances > 50 mm, the SAR test exclusion threshold is determined according to the following
 - a) [threshold at 50mm in step 1] + (test separation distance - 50mm) * (f (MHz)/150)] mW, at 100 MHz to 1500 MHz
 - b) [threshold at 50mm in step 1] + (test separation distance - 50mm) * 10] mW at > 1500 MHz and ≤ 6 GHz
6. Per KDB 248227 D01v01r02, choose the highest output power channel to test SAR and determine further SAR exclusion 8. for each frequency band, testing at higher data rates and higher order modulations is not required when the maximum average output power for each of each of these configurations is less than 1/4dB higher than those measured at the lower data rate than 11b mode, thus the SAR can be excluded.
7. Per KDB 941225 D07 UMPC Mini Tablet v01r02: UMPC mini-tablet devices must be tested for 1-g SAR on all surfaces and side edges with a transmitting antenna located at ≤ 25 mm from that surface or edge.

8. EUT Test Position

8.1 Define Two Imaginary Lines On The Handset

- (1) The vertical centerline passes through two points on the front side of the handset: the midpoint of the width w_t of the handset at the level of the acoustic output, and the midpoint of the width w_b of the handset.
- (2) The horizontal line is perpendicular to the vertical centerline and passes through the center of the acoustic output. The horizontal line is also tangential to the face of the handset at point A.
- (3) The two lines intersect at point A. Note that for many handsets, point A coincides with the center of the acoustic output; however, the acoustic output may be located elsewhere on the horizontal line. Also note that the vertical centerline is not necessarily to the front face of the handset, especially for clamshell handsets, handsets with flip covers, and other irregularly shaped handsets.

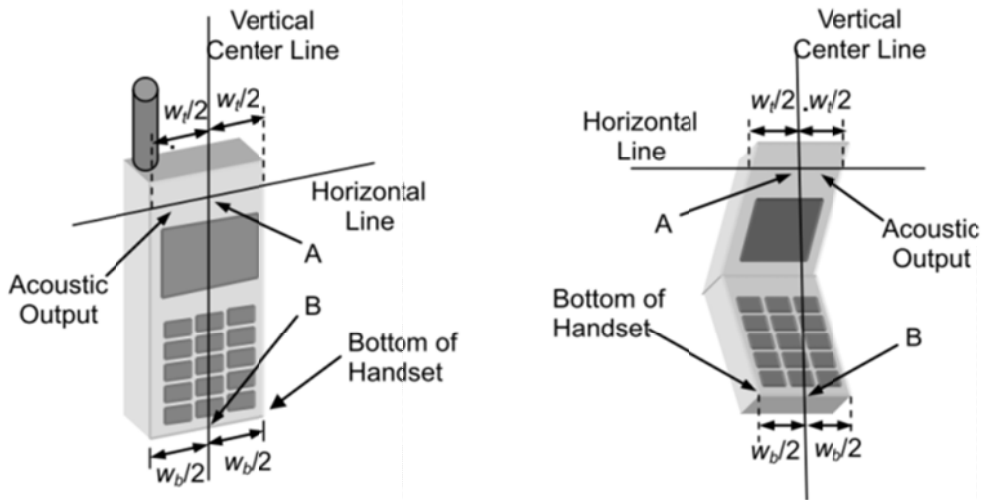

Body-worn Position Conditions

- (1) To position the EUT parallel to the phantom surface.
- (2) To adjust the EUT parallel to the flat phantom.
- (3) To adjust the distance between the EUT surface and the flat phantom to 5mm.

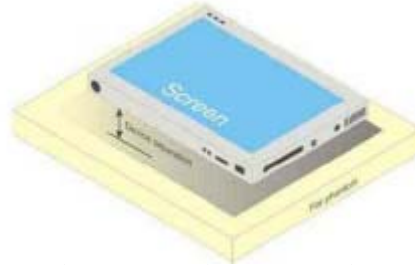

9. Uncertainty

9.1 Measurement Uncertainty

The following measurement uncertainty levels have been estimated for tests performed on the EUT as specified in IEEE 1528: 2013. This uncertainty represents an expanded uncertainty expressed at approximately the 95% confidence level using a coverage factor of k=2.

NO	Source	Tol(%)	Prob. Dist.	Div. k	ci (1g)	ci (10g)	1gUi	10gUi	Veff
Measurement System									
1	Probe calibration	5.8	N	1	1	1	5.8	5.8	∞
2	Axial isotropy	3.5	R	$\sqrt{3}$	$(1-cp)^{1/2}$	$(1-cp)^{1/2}$	1.43	1.43	∞
3	Hemispherical isotropy	5.9	R	$\sqrt{3}$	$\sqrt{C_p}$	$\sqrt{C_p}$	2.41	2.41	∞
4	Boundary effect	1.0	R	$\sqrt{3}$	1	1	0.58	0.58	∞
5	Linearity	4.7	R	$\sqrt{3}$	1	1	2.71	2.71	∞
6	System Detection limits	1.0	R	$\sqrt{3}$	1	1	0.58	0.58	∞
7	Readout electronics	0.5	N	1	1	1	0.50	0.50	∞
8	Response time	0	R	$\sqrt{3}$	1	1	0	0	∞
9	Integration time	1.4	R	$\sqrt{3}$	1	1	0.81	0.81	∞
10	Ambient noise	3.0	R	$\sqrt{3}$	1	1	1.73	1.73	∞
11	Ambient reflections	3.0	R	$\sqrt{3}$	1	1	1.73	1.73	∞
12	Probe positioner mech. restrictions	1.4	R	$\sqrt{3}$	1	1	0.81	0.81	∞
13	Probe positioning with respect to phantom shell	1.4	R	$\sqrt{3}$	1	1	0.81	0.81	∞
14	Max.SAR evaluation	1.0	R	$\sqrt{3}$	1	1	0.6	0.6	∞
Test sample related									
15	Device positioning	2.6	N	1	1	1	2.6	2.6	11
16	Device holder	3	N	1	1	1	3.0	3.0	7



17	Drift of output power	5.0	R	$\sqrt{3}$	1	1	2.89	2.89	∞
Phantom and set-up									
18	Phantom uncertainty	4.0	R	$\sqrt{3}$	1	1	2.31	2.31	∞
19	Liquid conductivity (target)	2.5	N	1	0.78	0.71	1.95	1.78	5
20	Liquid conductivity (meas)	4	N	1	0.23	0.26	0.92	1.04	5
21	Liquid Permittivity (target)	2.5	N	1	0.78	0.71	1.95	1.78	∞
22	Liquid Permittivity (meas)	5.0	N	1	0.23	0.26	1.15	1.30	∞
Combined standard			RSS	$U_C = \sqrt{\sum_{i=1}^n C_i^2 U_i^2}$			10.63%	10.54%	
Expanded uncertainty (P=95%)		$U = k U_C, k=2$					21.26%	21.08%	

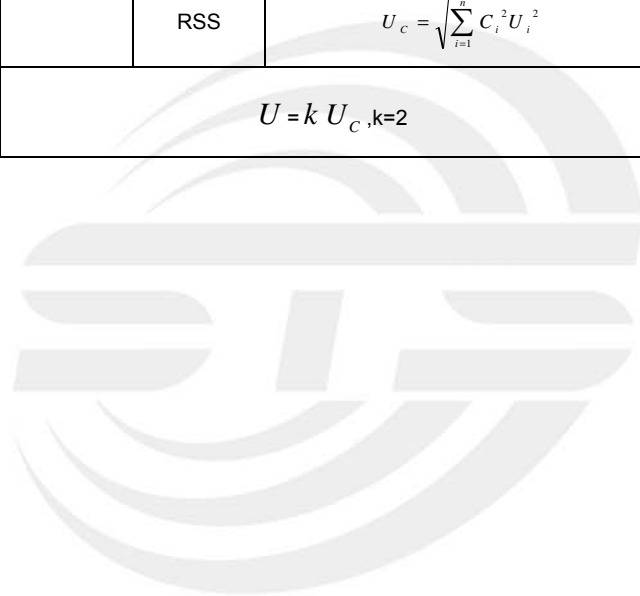

9.2 System validation Uncertainty

NO	Source	Tol(%)	Prob. Dist.	Div. k	ci (1g)	ci (10g)	1gUi	10gUi	Veff
Measurement System									
1	Probe calibration	5.8	N	1	1	1	5.8	5.8	∞
2	Axial isotropy	3.5	R	$\sqrt{3}$	$(1-cp)^{1/2}$	$(1-cp)^{1/2}$	1.43	1.43	∞
3	Hemispherical isotropy	5.9	R	$\sqrt{3}$	$\sqrt{C_p}$	$\sqrt{C_p}$	2.41	2.41	∞
4	Boundary effect	1.0	R	$\sqrt{3}$	1	1	0.58	0.58	∞
5	Linearity	4.7	R	$\sqrt{3}$	1	1	2.71	2.71	∞
6	System Detection limits	1.0	R	$\sqrt{3}$	1	1	0.58	0.58	∞
7	Modulation response	0	N	1	1	1	0	0	∞
8	Readout electronics	0.5	N	1	1	1	0.50	0.50	∞
9	Response time	0	R	$\sqrt{3}$	1	1	0	0	∞
10	Integration time	1.4	R	$\sqrt{3}$	1	1	0.81	0.81	∞
11	Ambient noise	3.0	R	$\sqrt{3}$	1	1	1.73	1.73	∞
12	Ambient reflections	3.0	R	$\sqrt{3}$	1	1	1.73	1.73	∞
13	Probe positioner mech. restrictions	1.4	R	$\sqrt{3}$	1	1	0.81	0.81	∞
14	Probe positioning with respect to phantom shell	1.4	R	$\sqrt{3}$	1	1	0.81	0.81	∞
15	Max.SAR evaluation	1.0	R	$\sqrt{3}$	1	1	0.6	0.6	∞
Dipole									
16	Deviation of experimental source from	4	N	1	1	1	4.00	4.00	∞
17	Input power and SAR drit measurement	5	R	$\sqrt{3}$	1	1	2.89	2.89	∞



18	Dipole Axis to liquid Distance	2	R	$\sqrt{3}$	1	1			∞
Phantom and set-up									
19	Phantom uncertainty	4.0	R	$\sqrt{3}$	1	1	2.31	2.31	∞
20	Uncertainty in SAR correction for deviation(in permittivity and	2.0	N	1	1	0.84	2	1.68	∞
21	Liquid conductivity (target)	2	N	1	1	0.84	2.00	1.68	∞
22	Liquid conductivity (temperature uncertainty)	2.5	N	1	0.78	0.71	1.95	1.78	5
23	Liquid conductivity (meas)	4	N	1	0.23	0.26	0.92	1.04	5
24	Liquid Permittivity (target)	2.5	N	1	0.78	0.71	1.95	1.78	∞
25	Liquid Permittivity (temperature uncertainty)	2.5	N	1	0.78	0.71	1.95	1.78	5
26	Liquid Permittivity (meas)	5.0	N	1	0.23	0.26	1.15	1.30	∞
Combined standard			RSS	$U_c = \sqrt{\sum_{i=1}^n C_i^2 U_i^2}$			10.15%	10.05%	
Expanded uncertainty (P=95%)		$U = k U_c, k=2$					20.29%	20.10%	

10. Conducted Power Measurement

10.1 Output power (Average) (dBm):

2.4Gband

Mode	Channel Number	Frequency (MHz)	Average Power (dBm)
IEEE 802.11 b	1	2412	9.39
	6	2437	12.58
	11	2462	15.09
IEEE 802.11g	1	2412	14.75
	6	2437	15.17
	11	2462	15.40
IEEE 802.11n HT20	1	2412	14.91
	6	2437	15.34
	11	2462	15.19
IEEE 802.11n HT40	1	2412	14.51
	6	2437	14.60
	11	2462	14.60

	Frequency (MHz)	Average Power (dBm)
5.8GHz (Antenna 1)	5745	20.11
	5777	18.72
	5810	18.20
5.8GHz (Antenna 2)	5745	18.64
	5777	18.99
	5810	18.05

10.2 Turn Power

Manufacturing tolerance

WIFI 2.4GHz

IEEE 802.11b (AVG)			
Frequency (MHz)	2412	2437	2462
Target (dBm)	9.0	12.0	15.0
Tolerance ±(dB)	1.0	1.0	1.0
IEEE 802.11g (AVG)			
Frequency (MHz)	2412	2437	2462
Target (dBm)	14.0	15.0	15.0
Tolerance ±(dB)	1.0	1.0	1.0
IEEE 802.11n HT20 (AVG)			
Frequency (MHz)	2412	2437	2462
Target (dBm)	14.0	15.0	15.0
Tolerance ±(dB)	1.0	1.0	1.0
IEEE 802.11n HT40 (AVG)			
Frequency (MHz)	2422	2437	2452
Target (dBm)	14.0	14.0	14.0
Tolerance ±(dB)	1.0	1.0	1.0

5.8GHz

(AVG)				
Channel	Antenna	5745	5777	5810
Target (dBm)	Antenna 1	19.5	18.0	18.0
	Antenna 2	18.0	18.0	18.0
Tolerance ±(dB)		1.0	1.0	1.0

11. EUT and Test Setup Photo

11.1 EUT Photo

Front side



Back side



Top side



Bottom side



Left side



Right side



Bottom side



11.2 Setup Photo

Body Back side (the antennas in straight mode) - Zero



Body Back side (the antennas at 90 degrees) - Zero



Body front side (the antennas in straight mode) – Zero



Body front side (the antennas at 90 degrees) - Zero



Liquid depth (15 cm)



12. SAR Result Summary

12.1 Standalone SAR

Front Side

Test Position	Test Position	Test Mode	Freq. (MHz)	Result SAR _{1-g} (W/Kg)	Result SAR _{10-g} (W/Kg)	Power Drift(%)	Max. Turn-up Power (dBm)	Meas. Output Power (dBm)	Duty cycle(%)	Scaled SAR _{1-g} (W/Kg)	Scaled SAR _{10-g} (W/Kg)	Meas. No.
2.4GHz WLAN	/	802.11b	2462	0.129	0.059	-2.01	16.00	15.09	100%	0.159	0.073	/
	/	802.11g	2462	0.152	0.075	-3.12	16.00	15.40	100%	0.175	0.086	1
5.8GHz Antenna 1	Straight Mode	/	5745	0.141	0.065	-1.82	20.50	20.11	100%	0.154	0.071	/
	90 degrees	/	5745	0.124	0.059	-0.44	20.50	20.11	100%	0.136	0.065	/
5.8GHz Antenna 2	/	/	5777	0.201	0.124	0.39	19.00	18.99	100%	0.201	0.124	3

Back Side

Test Position	Test Position	Test Mode	Freq. (MHz)	Result SAR _{1-g} (W/Kg)	Result SAR _{10-g} (W/Kg)	Power Drift (%)	Max. Turn-up Power (dBm)	Meas. Output Power (dBm)	Duty cycle (%)	Scaled SAR _{1-g} (W/Kg)	Scaled SAR _{10-g} (W/Kg)	Meas. No.
2.4GHz WLAN	/	802.11b	2462	0.492	0.222	1.19	16.00	15.09	100%	0.607	0.274	/
		802.11g	2462	0.573	0.295	2.40	16.00	15.40	100%	0.658	0.339	2
5.8GHz Antenna 2	/	/	5745	0.379	0.171	4.10	19.00	18.99	100%	0.379	0.171	/
5.8GHz Antenna 1	Straight Mode	/	5745	0.773	0.451	-3.85	20.50	20.11	100%	0.846	0.493	4
		/	5777	0.681	0.366	3.18	19.00	18.72	100%	0.726	0.390	/
		/	5810	0.545	0.260	-2.09	19.00	18.20	100%	0.655	0.313	/
	90 degrees	/	5777	0.486	0.217	1.36	20.50	20.11	100%	0.532	0.237	/

Note:

1. The test separation of Limb-worn is 0mm. The test separation of Back side is 0mm.
2. We not test distance at 10mm for Front side as we test distance at 0mm distance.
3. We not test distance at 10mm for Back side as we test distance at 0mm distance.
4. The 5.8G two antenna does not work at the same time, an antenna is working, and another antenna does not work.
5. We not test at 10mm for body if results of at zero meet FCC body limits.

12.2 Synchronization SAR

As 2.4GHzWLAN and 5.8GHz Wireless modular share difference antenna, we need consider transmit synchronization, more information as follows;

Modular	Antenna	Standalone TX	Synchronization TX
2.4GHz WLAN	Antenna 0	<input checked="" type="checkbox"/> Yes <input type="checkbox"/> No	Antenna 0 and Antenna 1 <input checked="" type="checkbox"/> Yes <input type="checkbox"/> No
5.8GHz Wireless	Antenna 1	<input checked="" type="checkbox"/> Yes <input type="checkbox"/> No	Antenna 0 and Antenna 2 <input checked="" type="checkbox"/> Yes <input type="checkbox"/> No
	Antenna 2	<input checked="" type="checkbox"/> Yes <input type="checkbox"/> No	Antenna 1 and Antenna 2 <input type="checkbox"/> Yes <input checked="" type="checkbox"/> No
			Antenna 0 and Antenna 1 and Antenna 2 <input type="checkbox"/> Yes <input checked="" type="checkbox"/> No

Limb-worn Exposure Conditions

Simultaneous transmission SAR for 2.4GWLAN and 5.8G Wireless Modular

Test Position	2.4GWLAN Reported SAR _{10-g} (W/Kg)	5.8GHz Antenna 1 Reported SAR _{10-g} (W/Kg)	5.8GHz Antenna 2 Reported SAR _{10-g} (W/Kg)	MAX. ΣSAR _{10-g} (W/Kg)	SAR _{10-g} Limit (W/Kg)	Peak location separation ratio	Simut. Meas. Required
Front Side	0.399	0.493	0.171	0.892	4.0	no	no

Body Exposure Conditions

Simultaneous transmission SAR for 2.4GWLAN and 5.8G Wireless Modular

Test Position	2.4GWLAN Reported SAR _{1-g} (W/Kg)	5.8GHz Antenna 1 Reported SAR _{1-g} (W/Kg)	5.8GHz Antenna 2 Reported SAR _{1-g} (W/Kg)	MAX. ΣSAR _{1-g} (W/Kg)	SAR _{1-g} Limit (W/Kg)	Peak location separation ratio	Simut. Meas. Required
Front Side	0.658	0.846	0.379	1.504	1.6	no	no

Note:

1. The test separation of Limb-worn is 0mm. The test separation of Back side is 0mm.
2. We not test distance at 10mm for Front side as we test distance at 0mm distance.
3. We not test distance at 10mm for Back side as we test distance at 0mm distance.
4. The 5.8G two antenna does not work at the same time, an antenna is working, and another antenna does not work.
5. We not test at 10mm for body if results of at zero meet FCC body limits.

13. Equipment List

Kind of Equipment	Manufacturer	Type No.	Serial No.	Last Calibration	Calibrated Until
2450MHz Dipole	SATIMO	SID2450	SN 30/14 DIP2G450-335	2014.09.01	2017.08.31
Waveguide	SATIMO	SWG5500	SN 13/14 WGA32	2014.09.01	2017.08.31
E-Field Probe	MVG	SSE2	SN 45/15 EPMO281	2015.10.12	2016.10.11
Antenna	SATIMO	ANTA3	SN 07/13 ZNTA52	2014.09.01	2017.08.31
Phantom1	SATIMO	SAM	SN 32/14 SAM115	N/A	N/A
Phantom2	SATIMO	SAM	SN 32/14 SAM116	N/A	N/A
SAR TEST BENCH	SATIMO	GSM and WCDMA mobile phone POSITIONING SYSTEM	SN 32/14 MSH97	N/A	N/A
SAR TEST BENCH	SATIMO	LAPTOP POSITIONING SYSTEM	SN 32/14 LSH29	N/A	N/A
Dielectric Probe Kit	SATIMO	SCLMP	SN 32/14 OCPG52	2015.09.01	2016.08.31
Multi Meter	Keithley	Multi Meter 2000	4050073	2015.11.20	2016.11.19
Signal Generator	Agilent	N5182A	MY50140530	2015.11.18	2016.11.17
Power Meter	R&S	NRP	100510	2015.10.25	2016.10.24
Power Sensor	R&S	NRP-Z11	101919	2015.10.24	2016.10.23
Power Sensor	R&S	NRP-Z21	103971	2015.12.12	2016.12.11
Network Analyzer	Agilent	5071C	EMY46103472	2015.12.12	2016.12.11
Attenuator 1	PE	PE7005-10	N/A	2015.10.25	2016.10.24
Attenuator 2	PE	PE7005-3	N/A	2015.10.24	2016.10.23
Attenuator 3	Woken	WK0602-XX	N/A	2015.12.12	2016.12.11
Dual Directional Coupler	Agilent	778D	50422	2015.11.18	2016.11.17

Appendix A. System Validation Plots

System Performance Check Data (2450MHz Body)

Type: Phone measurement (Complete)

Area scan resolution: dx=8mm,dy=8mm

Zoom scan resolution: dx=8mm, dy=8mm, dz=5mm

Date of measurement: 2016-04-05

Measurement duration: 14 minutes 23 seconds

Experimental conditions.

Device Position	Validation plane
Band	2450 MHz
Channels	-
Signal	CW
Frequency (MHz)	2450
Relative permittivity (real part)	52.41
Relative permittivity	12.930000
Conductivity (S/m)	1.93
Power drift (%)	-1.200000
Ambient Temperature	22.7°C
Liquid Temperature	21.5°C
Probe	SN 45/15 EPGO281
ConvF	2.28
Crest factor:	1:1

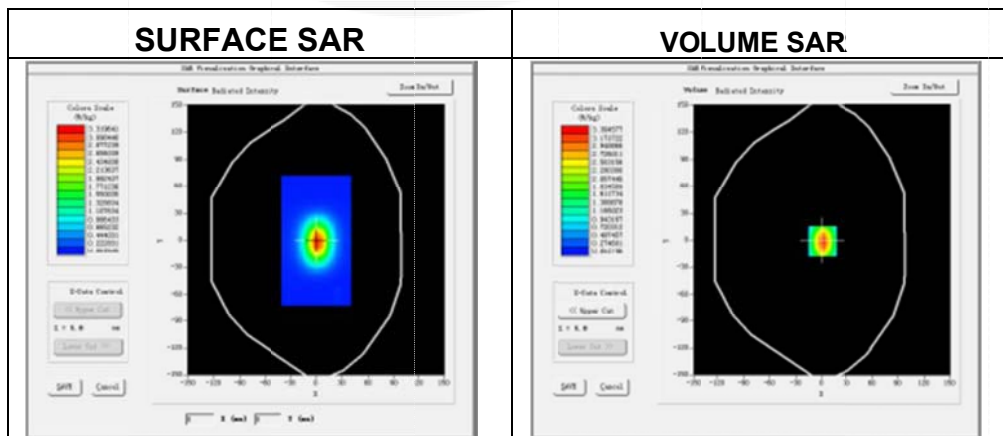

Maximum location: X=3.00, Y=1.00

SAR 10g (W/Kg)	2.536281
SAR 1g (W/Kg)	5.12665

Z Axis Scan

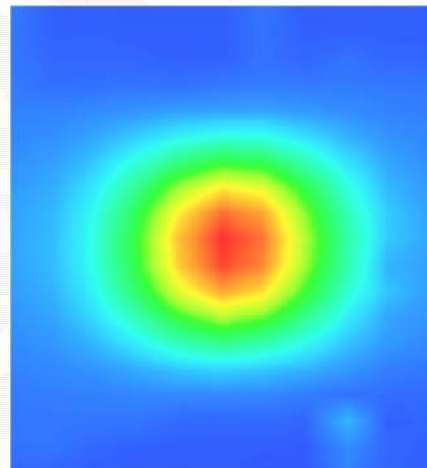
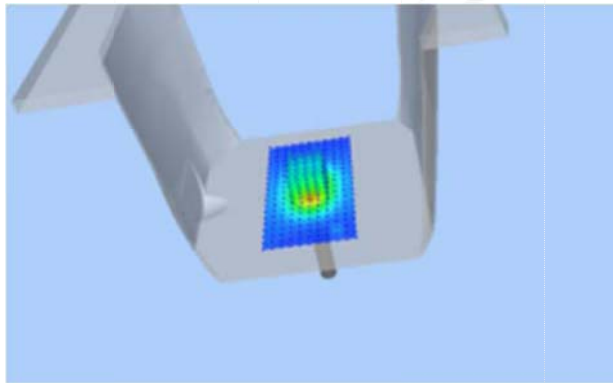
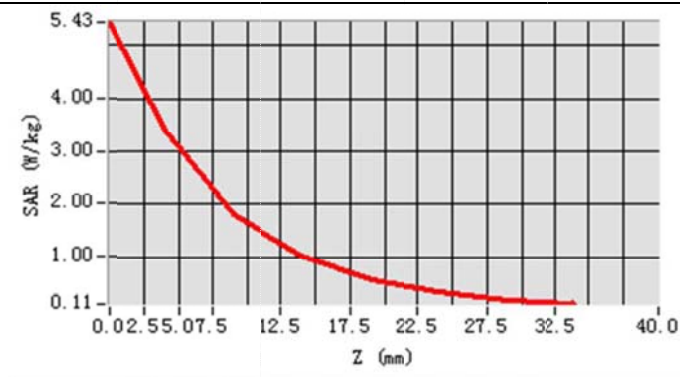

System Performance Check Data(5800MHz Body)

Type: Phone measurement (Complete)

Area scan resolution: dx=8mm,dy=8mm

Zoom scan resolution: 4x4x2,dx=4mm dy=4mm dz=2mm,

Date of measurement: 2016.04.05

Experimental conditions.

Device Position	Validation plane
Band	5800 MHz
Channels	-
Signal	CW
Frequency (MHz)	5800
Relative permittivity (real part)	47.640002
Relative permittivity (imaginary)	6.2500000
Conductivity (S/m)	5.715278
Power drift (%)	4.140000
Ambient Temperature	22.7°C
Liquid Temperature	22.3°C
Probe	SN 45/15 EPGO281
ConvF	2.60
Crest factor:	1:1

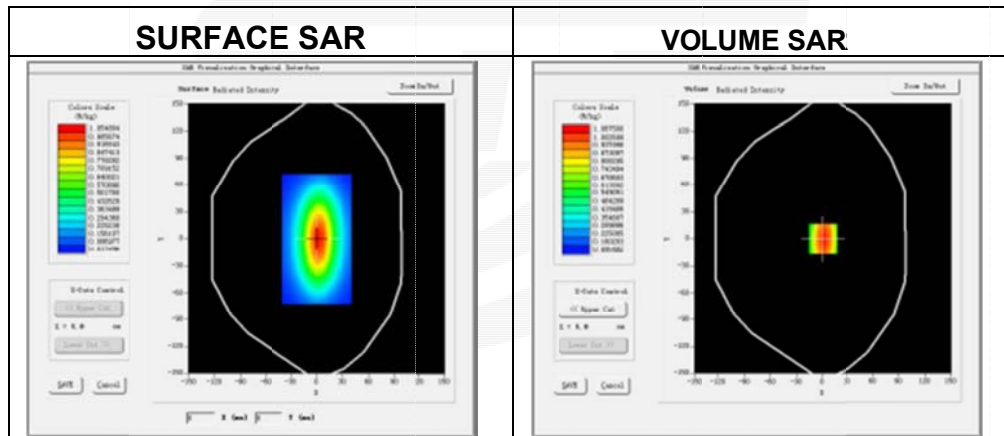

Maximum location: X=7.00, Y=2.00

SAR 10g (W/Kg)	5.643525
SAR 1g (W/Kg)	18.577541

Z Axis Scan

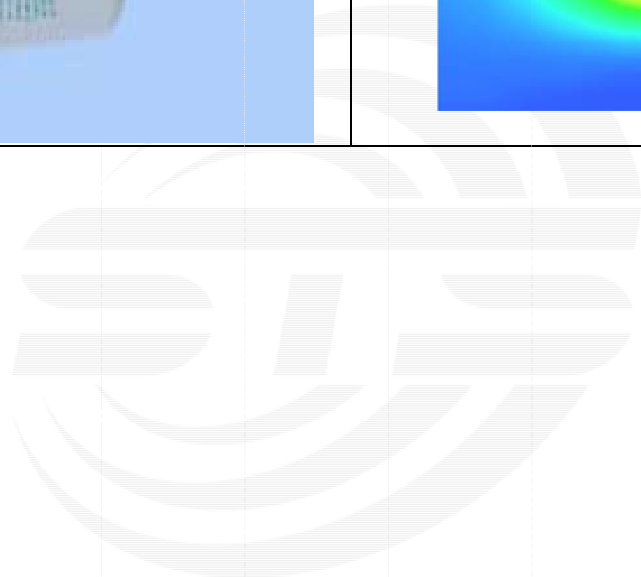
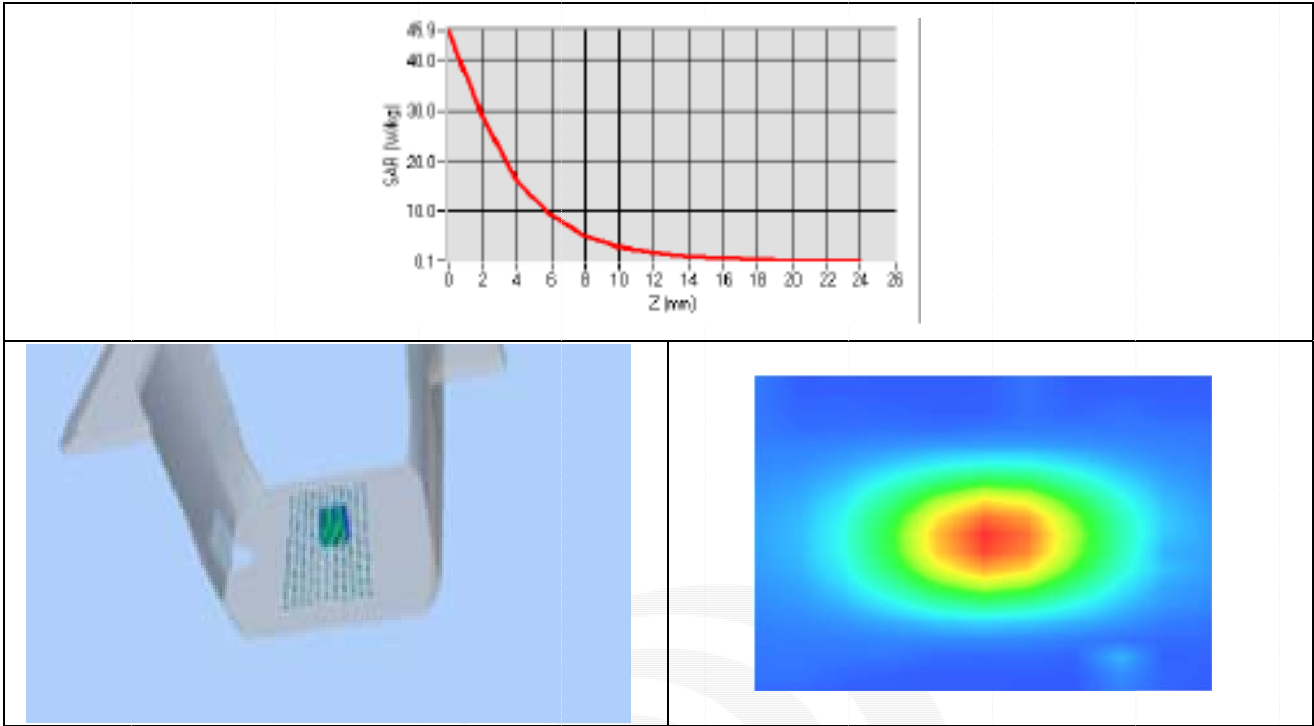

Appendix B. SAR Test Plots

Plot 1: DUT: Prodrone byrd; EUT Model: CME01-M2

Test Data	2016-04-05
Probe	SN 45/15 EPGO281
Conv F	2.28
Area Scan	dx=8mm dy=8mm, h= 5.00 mm
Zoom Scan	5x5x7,dx=5mm dy=5mm dz=4mm, Complete/ndx=5mm dy=5mm, h= 5.00 mm
Phantom	Validation plane
Device Position	Limb-worn(back side)
Band	2.4GHz/IEEE 802.11g
Channels	High
Signal	Crest factor: 1.0
Frequency (MHz)	2462
Relative permittivity (real part)	51.2
Conductivity (S/m)	1.95
Variation (%)	-3.12

Maximum location: X=25.00, Y=-20.00
SAR Peak: 0.27 W/kg

SAR 10g (W/Kg)	0.075230
SAR 1g (W/Kg)	0.152111

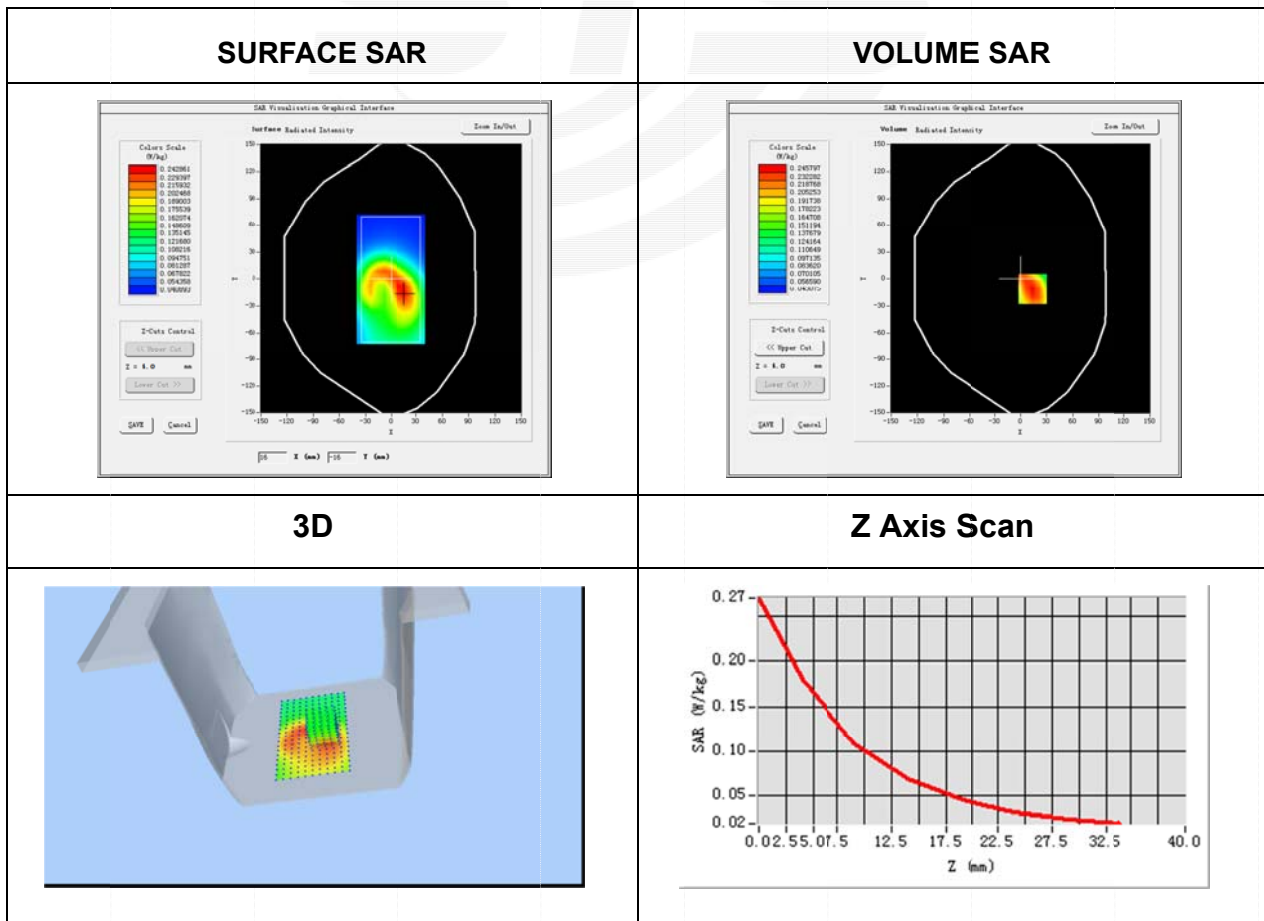

Plot 2: DUT: Prodrone byrd; EUT Model: CME01-M2

Test Data	2016-05-16
Probe	SN 45/15 EPGO281
Conv F	2.28
Area Scan	dx=8mm dy=8mm, h= 5.00 mm
Zoom Scan	5x5x7,dx=5mm dy=5mm dz=4mm, Complete/ndx=5mm dy=5mm, h= 5.00 mm
Phantom	Validation plane
Device Position	Body (Front Size)
Band	2.4GHz/IEEE 802.11g
Channels	High
Signal	Crest factor: 1.0
Frequency (MHz)	2462
Relative permittivity (real part)	51.2
Conductivity (S/m)	1.95
Variation (%)	2.40

Maximum location: X=10.00, Y=13.00
SAR Peak: 0.93 W/kg

SAR 10g (W/Kg)	0.294744
SAR 1g (W/Kg)	0.573252

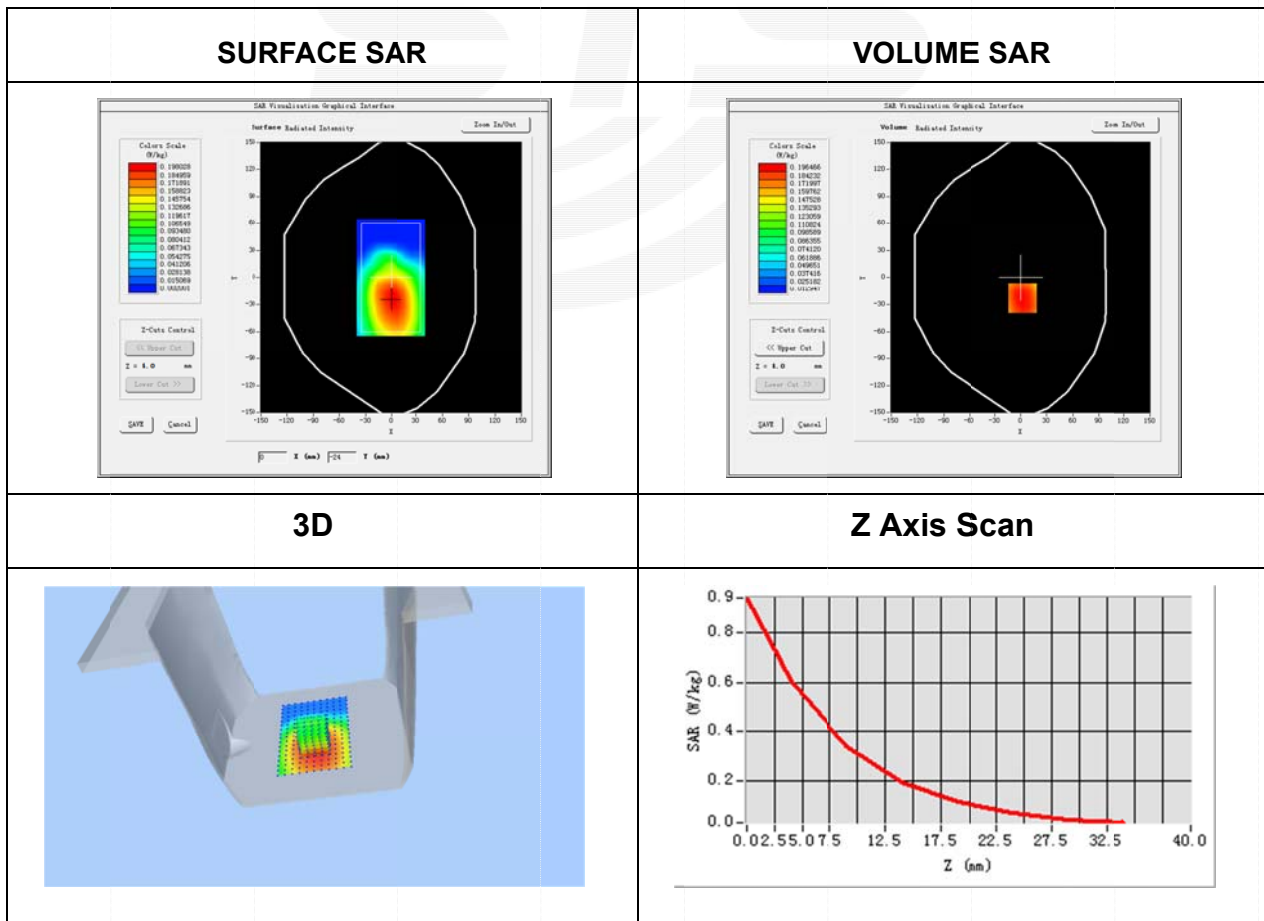

Plot 3: Prodrone byrd; EUT Model: CME01-M2

Test Data	2016-04-05
Probe	SN 45/15 EPGO281
ConvF	2.60
Area Scan	dx=8mm dy=8mm, h= 5.00 mm
ZoomScan	4x4x2,dx=4mm dy=4mm dz=2mm, Complete/ndx=4mm dy=4mm, h= 2.00 mm
Phantom	Validation plane
Device Position	Limb-worn(Back Size)
Band	5.8GHz
Channels	Middle
Signal	Crest factor: 1.0
Frequency (MHz)	5777
Relative permittivity (real part)	49.1
Conductivity (S/m)	5.29
Variation (%)	0.39

Maximum location: X=10.00, Y=31.00
SAR Peak: 0.35 W/kg

SAR 10g (W/Kg)	0.123681
SAR 1g (W/Kg)	0.201496

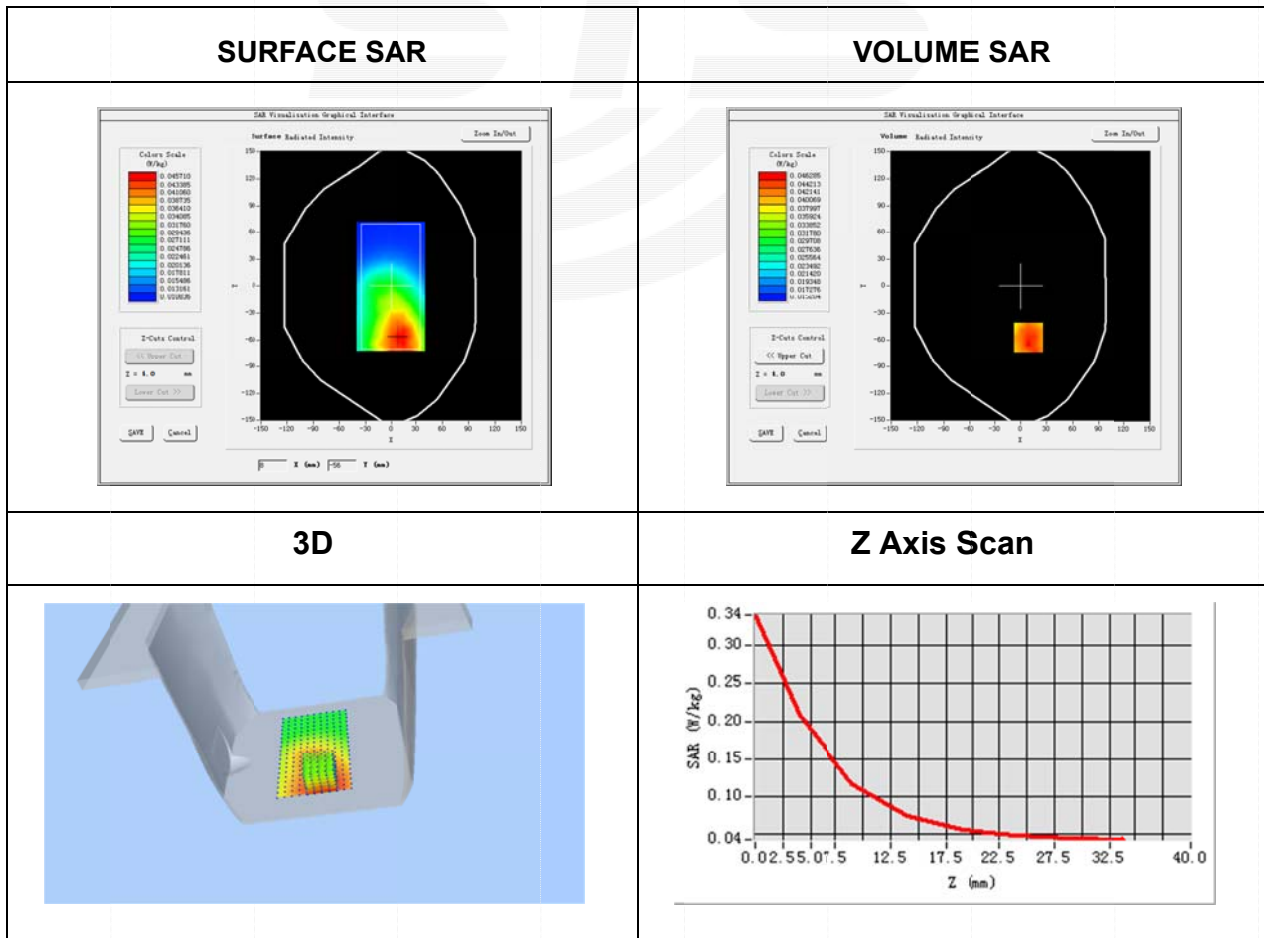

Plot 4: Prodrone byrd; EUT Model: CME01-M2

Test Data	2016-05-16
Probe	SN 45/15 EPGO281
ConvF	2.60
Area Scan	dx=8mm dy=8mm, h= 5.00 mm
ZoomScan	4x4x2,dx=4mm dy=4mm dz=2mm, Complete/ndx=4mm dy=4mm, h= 2.00 mm
Phantom	Validation plane
Device Position	Body (Front Size)
Band	5.8GHz
Channels	Low
Signal	Crest factor: 1.0
Frequency (MHz)	5745
Relative permittivity (real part)	49.1
Conductivity (S/m)	5.29
Variation (%)	-3.85

Maximum location: X=9.00, Y=-38.00
SAR Peak: 1.07 W/kg

SAR 10g (W/Kg)	0.451289
SAR 1g (W/Kg)	0.773245

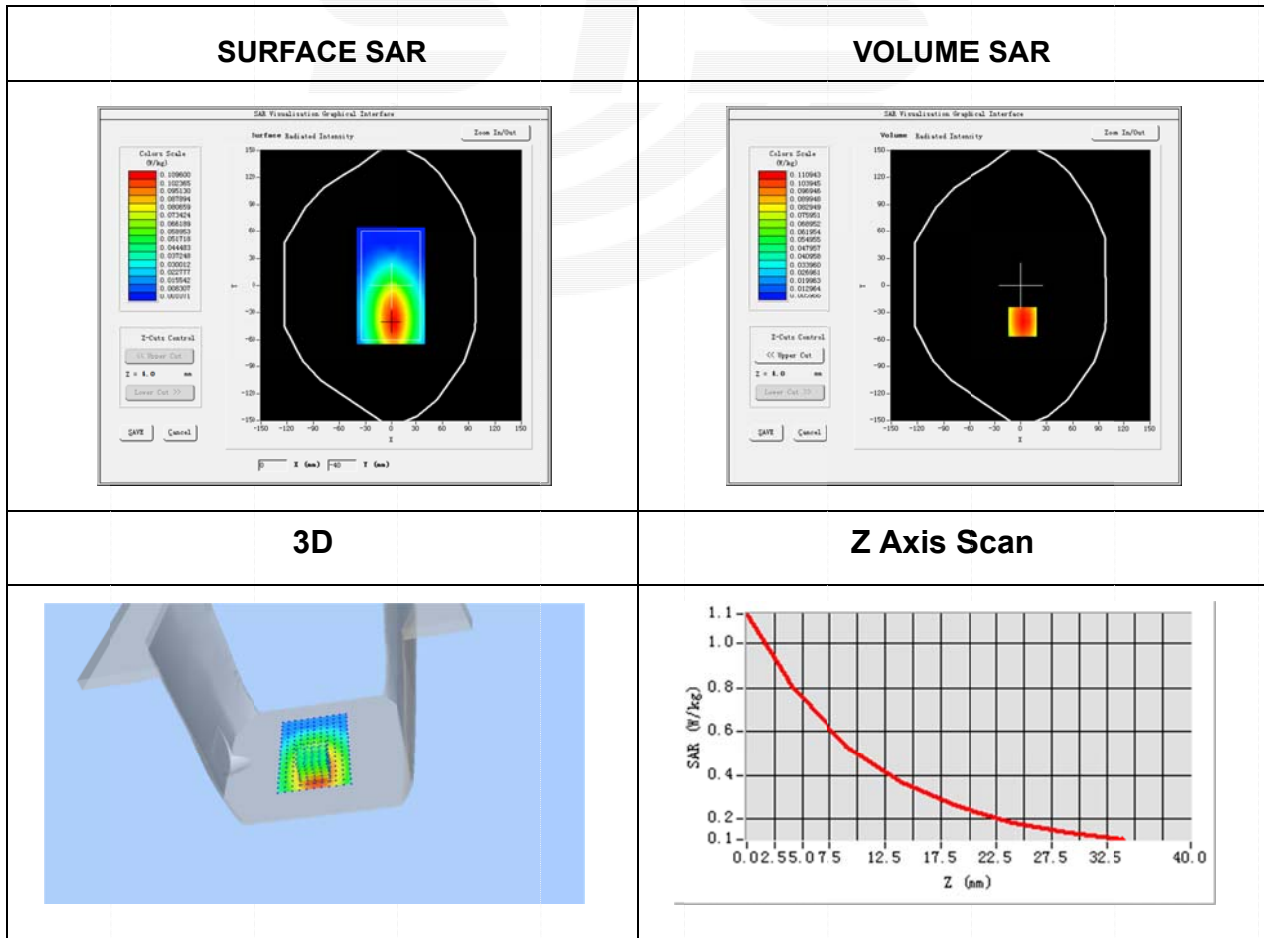



Appendix C. Probe Calibration And Dipole Calibration Report

Refer the appendix Calibration Report.

※※※※END OF THE REPORT※※※※

