



FCC 47 CFR PART 15 SUBPART C

for

ProDrone Byrd

Model: MGP01-B, MGP01-C

Brand: N/A

Test Report Number:

C160317Z02-RP1-1

Issued Date: March 31, 2016

Issued for

Prodrone Technology (Shenzhen) Co.,Ltd

**8th Floor, Beike Building, South High Technology Park, Nanshan District,
Shenzhen**

Issued by:

Compliance Certification Services (Shenzhen) Inc.

No.10-1 Mingkeda Logistics park, No.18, Huanguan South Rd.,

Guan Lan Town, Baoan District, Shenzhen, China

TEL: 86-755-28055000

FAX: 86-755-28055221

E-Mail: service@ccssz.com



TESTING CERT #2861.01

Note: This report shall not be reproduced except in full, without the written approval of Compliance Certification Services (Shenzhen) Inc. This document may be altered or revised by Compliance Certification Services (Shenzhen) Inc. personnel only, and shall be noted in the revision section of the document. The client should not use it to claim product endorsement by TAF, A2LA, NVLAP, NIST or any government agencies. The test results in the report only apply to the tested sample.



Revision History

Rev.	Issue Date	Revisions	Effect Page	Revised By
00	March 31, 2016	Initial Issue	ALL	Sinphy Xie



TABLE OF CONTENTS

1 TEST CERTIFICATION 4

2 TEST RESULT SUMMARY 4

3 EUT DESCRIPTION..... 6

4 TEST METHODOLOGY..... 7

 4.1. DESCRIPTION OF TEST MODES 7

5 SETUP OF EQUIPMENT UNDER TEST 8

 5.1. DESCRIPTION OF SUPPORT UNITS..... 8

 5.2. CONFIGURATION OF SYSTEM UNDER TEST 8

6 FACILITIES AND ACCREDITATIONS 9

 6.1. FACILITIES..... 9

 6.2. ACCREDITATIONS 9

 6.3. MEASUREMENT UNCERTAINTY..... 9

7 FCC PART 15.247 REQUIREMENTS 10

 7.1. POWER LINE CONDUCTED EMISSIONS MEASUREMENT 10

 7.2. SPURIOUS EMISSIONS MEASUREMENT..... 13

 7.3. 6dB BANDWIDTH MEASUREMENT 45

 7.4. ANTENNA GAIN 55

 7.5. PEAK OUTPUT POWER 56

 7.6. BAND EDGES MEASUREMENT..... 59

 7.7. PEAK POWER SPECTRAL DENSITY MEASUREMENT..... 77



1 TEST CERTIFICATION

Product	ProDrone Byrd
Model	MGP01-B, MGP01-C
Brand	N/A
Tested	March 17~31, 2016
Applicant	Prodrone Technology (Shenzhen) Co.,Ltd 8th Floor, Beike Building, South High Technology Park, Nanshan District, Shenzhen
Manufacturer	Prodrone Technology (Shenzhen) Co.,Ltd 8th Floor, Beike Building, South High Technology Park, Nanshan District, Shenzhen

APPLICABLE STANDARDS			
Standard	Test Type	Standard	Test Type
15.207(a)	Power Line Conducted Emissions	15.247(d) 15.209(a)	<ul style="list-style-type: none"> ● Spurious Emissions ● Conducted Measurement ● Radiated Emissions
15.247(a)(2)	6dB Bandwidth Measurement	15.247(b)(3) 15.247(b)(4)	Peak Power Measurement
15.247(d)	Band Edges Measurement	15.247(e)	Peak Power Spectral Density

We hereby certify that:

The above equipment was tested by Compliance Certification Services (Shenzhen) Inc. The test data, data evaluation, test procedures, and equipment configurations shown in this report were made in accordance with the procedures given in **ANSI C63.10: 2013** and the energy emitted by the sample EUT tested as described in this report is in compliance with the requirements of FCC Rules Part 15.207, 15.209, 15.247. The test results of this report relate only to the tested sample EUT identified in this report.

Approved by:

Reviewed by:

Sunday Hu
Supervisor of EMC Dept.
Compliance Certification Services (Shenzhen) Inc.

Ruby Zhang
Supervisor of Report Dept.
Compliance Certification Services (Shenzhen) Inc.



2 TEST RESULT SUMMARY

APPLICABLE STANDARDS			
Standard	Test Type	Result	Remark
15.247(a)(2)	6dB Bandwidth Measurement	Pass	Meet the requirement of limit.
15.247(b)(3) 15.247(b)(4)	Peak Power Measurement	Pass	Meet the requirement of limit.
15.247(d)	Band Edges Measurement	Pass	Meet the requirement of limit.
15.247(e)	Peak Power Spectral Density	Pass	Meet the requirement of limit.
15.247(d) 15.209(a)	<ul style="list-style-type: none">● Spurious Emissions● Conducted Measurement● Radiated Emissions	Pass	Meet the requirement of limit.
15.207(a)	Power line Conducted Emissions	N/A	Not applicable, because the EUT received DC power from the battery.

Note: 1. The statements of test result on the above are decided by the request of test standard only; the measurement uncertainties are not factored into this compliance determination.
2. The information of measurement uncertainty is available upon the customer's request.



3 EUT DESCRIPTION

Product	ProDrone Byrd
Model Number	MGP01-B, MGP01-C
Brand	N/A
Model Discrepancy	MGP01-C is without camera, MGP01-B has a camera.
Identify Number	C160317Z02-RP1-1
Received Date	March 17, 2016
Power Supply	DC14.2V powered by battery
Battery specification	Model: PD1-7000mAh-4S Voltage: 14.2V Energy: 99.4mAh Capacity:7000mAh
Transmit Power	IEEE 802.11b mode: 18.34dBm IEEE 802.11g mode: 25.73dBm IEEE 802.11n HT20 MHz mode: 25.60dBm IEEE 802.11n HT40 MHz mode: 24.94dBm
Modulation Technique	IEEE 802.11b mode: DSSS(CCK,QPSK, BPSK) IEEE 802.11g mode: OFDM (BPSK/QPSK/16QAM/64QAM) IEEE 802.11n HT20 MHz mode: OFDM (BPSK/QPSK/16QAM/64QAM) IEEE 802.11n HT40 MHz mode: OFDM (BPSK/QPSK/16QAM/64QAM)
Transmit Data Rate	IEEE 802.11b: 11Mbps(CCK) with fall back rates of 5.5/2/1Mbps IEEE 802.11g: 54Mbps with fall back rates of 48/36/24/18/12/9 /6Mbps IEEE 802.11n HT20: 65.0Mbps with fall back rates of 65.0/58.5/52.0/ 39.0/26.0/19.5/13.0/6.5 Mbps IEEE 802.11n HT40: 135Mbps with fall back rates of 135/121.5/108/ 81/54/40.5/27/13.5Mbps
Number of Channels	IEEE 802.11b mode: 11 Channels IEEE 802.11g mode: 11 Channels IEEE 802.11n HT20 MHz mode: 11 Channels IEEE 802.11n HT40 MHz mode: 7 Channels
Antenna Specification	Dipole antenna with 2dBi gain (Max)
Channels Spacing	IEEE 802.11b/g ,802.11n HT20/HT40 : 5MHz
Temperature Range	-10°C ~ +50°C

- Note:** 1. The sample selected for test was engineering sample that approximated to production product and was provided by manufacturer.
2. This submittal(s) (test report) is intended for FCC ID: 2AGKH-PD-BYRD-0103 filing to comply with Section 15.207, 15.209 and 15.247 of the FCC Part 15, Subpart C Rules.



4 TEST METHODOLOGY

4.1. DESCRIPTION OF TEST MODES

The EUT has been tested under operating condition.

Software used to control the EUT for staying in continuous transmitting and receiving mode is programmed.

Test Item	Test mode	Worse mode
Conducted Emission	Not applicable, because the EUT received DC power from the battery.	<input type="checkbox"/>
Radiated Emission	Mode 1: TX	<input checked="" type="checkbox"/>

After verification, all tests were carried out with the worst case test modes as shown below except radiated spurious emission below 1GHz, which worst case was in normal link mode only, and power line conducted emission below 30MHz, which worst case was in normal link mode.

IEEE802.11b mode: Channel Low (2412MHz), Channel Mid (2437MHz) and Channel High (2462MHz) with 1Mbps data rate were chosen for full testing.

IEEE802.11g mode: Channel Low (2412MHz), Channel Mid (2437MHz) and Channel High (2462MHz) with 6Mbps data rate were chosen for full testing.

IEEE 802.11n HT20 MHz mode: Channel Low (2412MHz), Channel Mid (2437MHz) and Channel High (2462MHz) with 6.5Mbps data rate were chosen for full testing.

IEEE 802.11n HT40 MHz mode: Channel Low (2422MHz), Channel Mid (2437MHz) and Channel High (2452MHz) with 13.5Mbps data rate were chosen for full testing.



5 SETUP OF EQUIPMENT UNDER TEST

5.1. DESCRIPTION OF SUPPORT UNITS

The EUT has been tested as an independent unit together with other necessary accessories or support units. The following support units or accessories were used to form a representative test configuration during the tests.

No.	Equipment	Model No.	Serial No.	FCC ID	Brand	Data Cable	Power Cord
1	Notebook	B475	WB04861612	DoC	LENOVO	N/A	Unshielded, 1.80m

Note:

Grounding was established in accordance with the manufacturer's requirements and conditions for the intended use.

5.2. CONFIGURATION OF SYSTEM UNDER TEST

See test photographs attached in Appendix II for the actual connections between EUT and support equipment.



6 FACILITIES AND ACCREDITATIONS

6.1. FACILITIES

All measurement facilities used to collect the measurement data are located at **No.10-1 Mingkeda Logistics park, No.18, Huanguan South Rd., Guan Lan Town, Baoan District, Shenzhen, China**

The sites are constructed in conformance with the requirements of ANSI C63.10, ANSI C63.7 and CISPR Publication 22. All receiving equipment conforms to CISPR Publication 16-1, "Radio Interference Measuring Apparatus and Measurement Methods."

6.2. ACCREDITATIONS

Our laboratories are accredited and approved by the following accreditation body according to ISO/IEC 17025.

USA	A2LA
China	CNAS

The measuring facility of laboratories has been authorized or registered by the following approval agencies.

USA	FCC
Japan	VCCI(C-4815,R-4320,T-2317, G-10624)
Canada	INDUSTRY CANADA

Copies of granted accreditation certificates are available for downloading from our web site, <http://www.ccssz.com>

6.3. MEASUREMENT UNCERTAINTY

Where relevant, the following measurement uncertainty levels have been estimated for tests performed on the EUT as specified in CISPR 16-4-2:

Parameter	Uncertainty
Radiated Emission, 30 to 200 MHz Test Site : 966(2)	+/-3.6880dB
Radiated Emission, 200 to 1000 MHz Test Site : 966(2)	+/-3.6695dB
Radiated Emission, 1 to 8 GHz	+/-5.1782dB
Radiated Emission, 8 to 18 GHz	+/-5.2173dB
Conducted Emissions	+/-3.6836dB
Band Width	178kHz
Peak Output Power MU	+/-1.906dB
Band Edge MU	+/-0.182dB
Channel Separation MU	416.178Hz
Duty Cycle MU	0.054ms
Frequency Stability MU	226Hz

This uncertainty represents an expanded uncertainty expressed at approximately the 95% confidence level using a coverage factor of k=2.

The measured result is above (below) the specification limit by a margin less than the measurement uncertainty; it is therefore not possible to state compliance based on the 95% level of confidence. However, the result indicates that compliance (non-compliance) is more probable than non-compliance) with the specification limit.



7 FCC PART 15.247 REQUIREMENTS

7.1. POWER LINE CONDUCTED EMISSIONS MEASUREMENT

7.1.1. LIMITS OF CONDUCTED EMISSIONS MEASUREMENT

According to §15.207(a), except as shown in paragraphs (b) and (c) of this section, for an intentional radiator that is designed to be connected to the public utility (AC) power line, the radio frequency voltage that is conducted back onto the AC power line on any frequency or frequencies within the band 150 kHz to 30 MHz shall not exceed the limits in the following table, as measured using a 50 μ H/50 ohms line impedance stabilization network (LISN). Compliance with the provisions of this paragraph shall be based on the measurement of the radio frequency voltage between each power line and ground at the power terminal. The lower limit applies at the boundary between the frequency ranges.

Frequency Range (MHz)	Limits (dB μ V)	
	Quasi-peak	Average
0.15 to 0.50	66 to 56*	56 to 46*
0.50 to 5	56	46
5 to 30	60	50

NOTE:

- (1) The lower limit shall apply at the transition frequencies.
- (2) The limit decreases in line with the logarithm of the frequency in the range of 0.15 to 0.50 MHz.
- (3) All emanations from a class A/B digital device or system, including any network of conductors and apparatus connected thereto, shall not exceed the level of field strengths specified above.

7.1.2. TEST INSTRUMENTS

Conducted Emission Test Site					
Name of Equipment	Manufacturer	Model Number	Serial Number	Last Calibration	Due Calibration
EMI TEST RECEIVER	ROHDE&SCHWARZ	ESCI	100783	02/21/2016	02/20/2017
LISN(EUT)	ROHDE&SCHWARZ	ENV216	101543-WX	02/21/2016	02/20/2017
LISN	EMCO	3825/2	8901-1459	02/21/2016	02/20/2017
Temp. / Humidity Meter	VICTOR	HTC-1	N/A	02/21/2016	02/20/2017
Test S/W	FARAD	EZ-EMC/ CCS-3A1-CE			

- NOTE:**
1. The calibration interval of the above test instruments is 12 months and the calibrations are traceable to NML/ROC and NIST/USA.
 2. N.C.R = No Calibration Request.



7.1.3. TEST PROCEDURES (please refer to measurement standard)

- The EUT and Support equipment, if needed, was placed on a non-conducted table, which is 0.8m above the ground plane and 0.4m away from the conducted wall.
- The test equipment EUT installed received AC main power, through a Line Impedance Stabilization Network (LISN), which supplied power source and was grounded to the ground plane. All support equipment power received from a second LISN. The two LISNs provide 50 ohm/ 50uH of coupling impedance for the measuring instrument.
- The EUT test program was started. Emissions were measured on each current carrying line of the EUT using an EMI Test Receiver connected to the LISN powering the EUT.
- The frequency range from 150 kHz to 30 MHz was searched. The test data of the worst-case condition(s) was recorded. Emission levels under limit 20dB were not recorded.



7.1.4. TEST SETUP

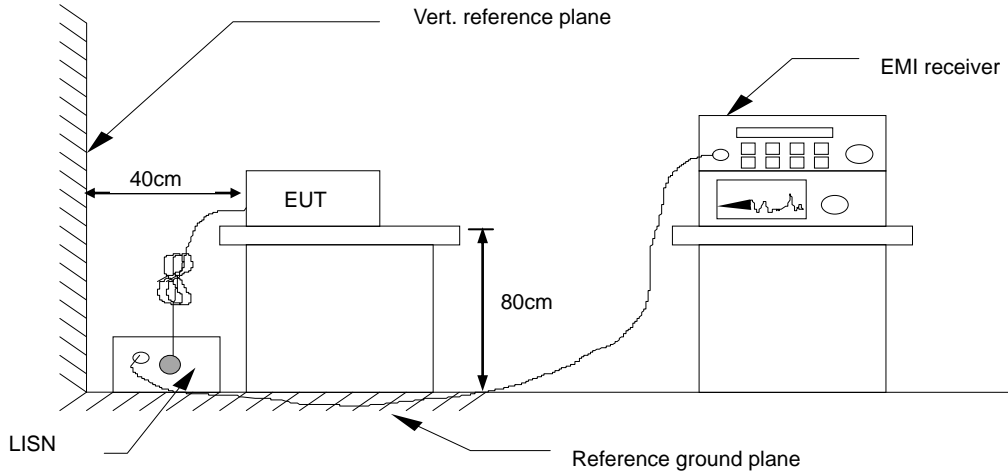

For the actual test configuration, please refer to the related item - Photographs of the Test Configuration.

7.1.5. DATA SAMPLE

Frequency (MHz)	QuasiPeak Reading (dBuV)	Average Reading (dBuV)	Correction Factor (dB)	QuasiPeak Result (dBuV)	Average Result (dBuV)	QuasiPeak Limit (dBuV)	Average Limit (dBuV)	QuasiPeak Margin (dB)	Average Margin (dB)	Remark (Pass/Fail)
X.XXXX	32.69	25.65	11.52	44.21	37.17	65.78	55.79	-21.57	-18.62	Pass

- Factor = Insertion loss of LISN + Cable Loss
- Result = Quasi-peak Reading/ Average Reading + Factor
- Limit = Limit stated in standard
- Margin = Result (dBuV) – Limit (dBuV)

7.1.6. TEST RESULTS

Not applicable, because the EUT received DC power from the battery.



7.2. SPURIOUS EMISSIONS MEASUREMENT

7.2.1. CONDUCTED EMISSIONS MEASUREMENT

7.2.1.1. LIMITS OF CONDUCTED EMISSIONS MEASUREMENT

§15.247(d) specifies that in any 100 kHz bandwidth outside of the authorized frequency band, the power shall be attenuated according to the following conditions:

If the peak output power procedure is used to measure the fundamental emission power to demonstrate compliance to 15.247(b)(3) requirements, then the peak conducted output power measured within any 100 kHz outside the authorized frequency band shall be attenuated by at least 20 dB relative to the maximum measured in-band peak PSD level.

If the average output power procedure is used to measure the fundamental emission power to demonstrate compliance to 15.247(b)(3) requirements, then the power in any 100 kHz outside of the authorized frequency band shall be attenuated by at least 30 dB relative to the maximum measured in-band average PSD level.

In addition, radiated emissions which fall in the restricted bands, as defined in §15.205(a), must also comply with the radiated emission limits specified in 15.209(a) (see Section 15.205(c)).

7.2.1.2. TEST INSTRUMENTS

Name of Equipment	Manufacturer	Model	Serial Number	Last Calibration	Due Calibration
Spectrum Analyzer	Agilent	E4446A	US44300399	02/21/2016	02/20/2017

7.2.1.3. TEST PROCEDURE (please refer to measurement standard)

Conducted RF measurements of the transmitter output were made to confirm that the EUT antenna port conducted emissions meet the specified limit and to identify any spurious signals that require further investigation or measurements on the radiated emissions site.

The transmitter output is connected to the spectrum analyzer. The resolution bandwidth is set to 100 kHz. The video bandwidth is set to 300 kHz.

Measurements are made over the 10MHz to 26GHz range with the transmitter set to the lowest, middle, and highest channels. No emission found between lowest internal used/generated frequency to 10MHz, it is only recorded 10MHz to 26GHz.



7.2.1.4. TEST RESULTS

Test Plot
IEEE 802.11b mode

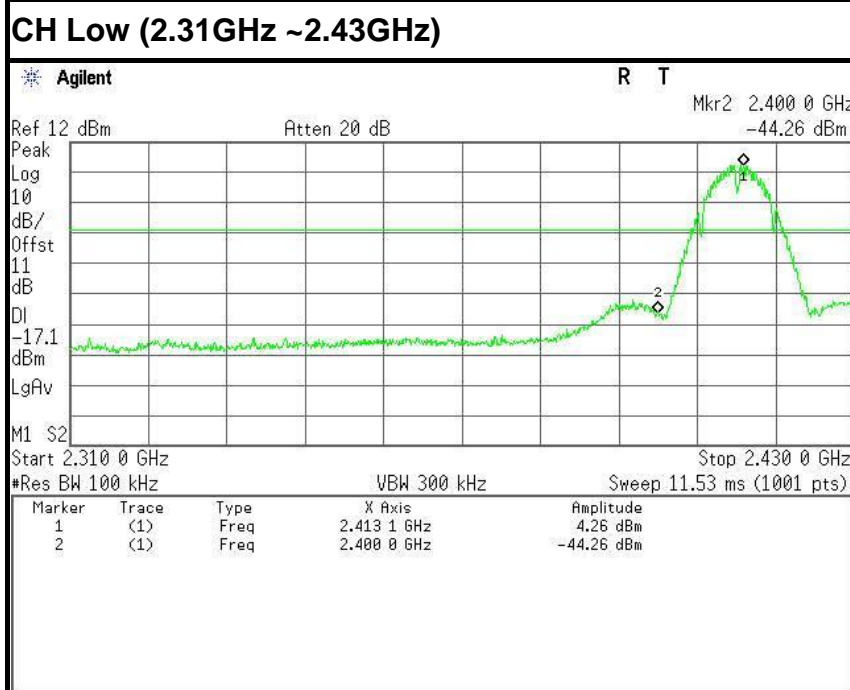
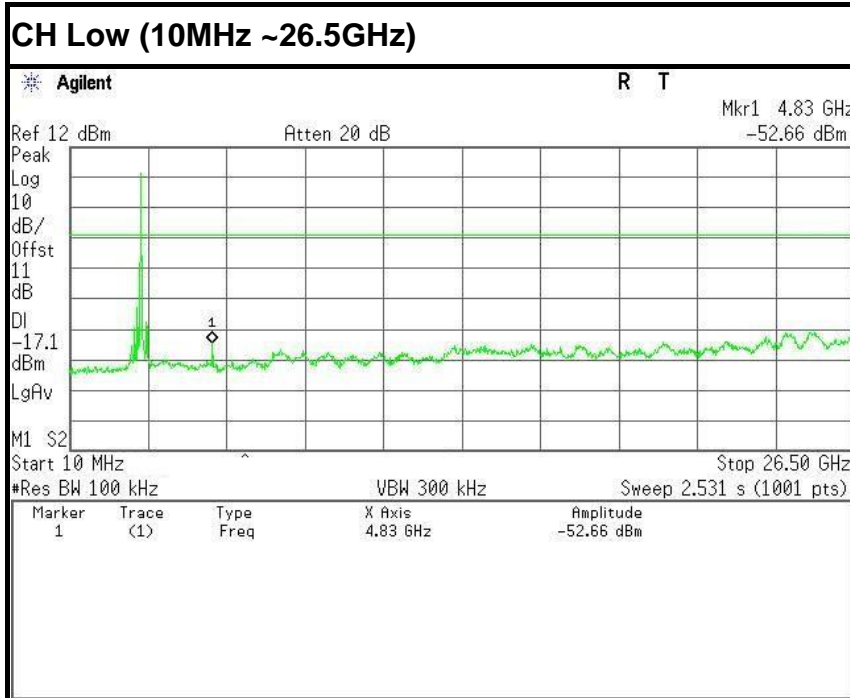

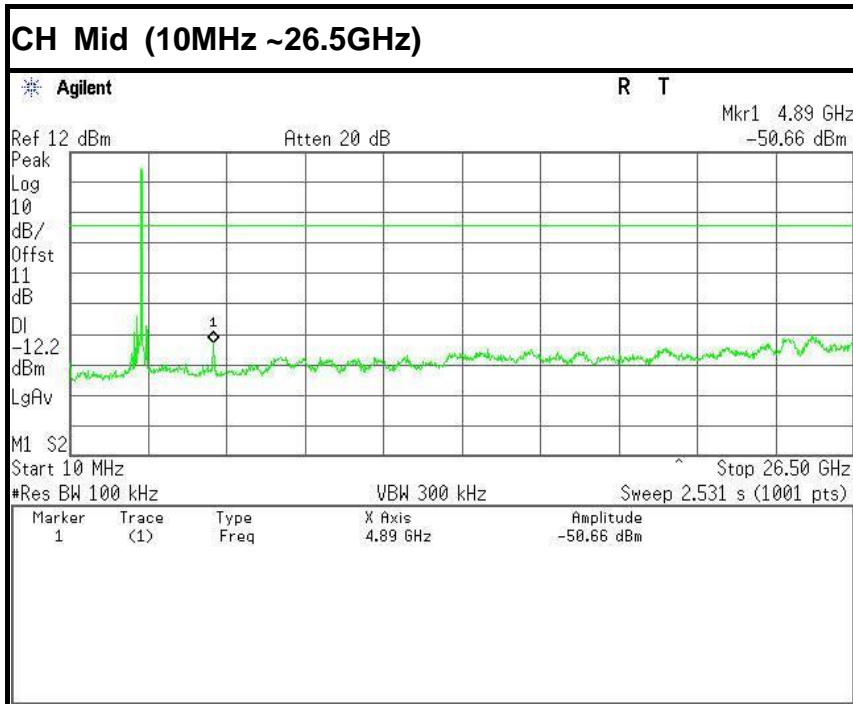

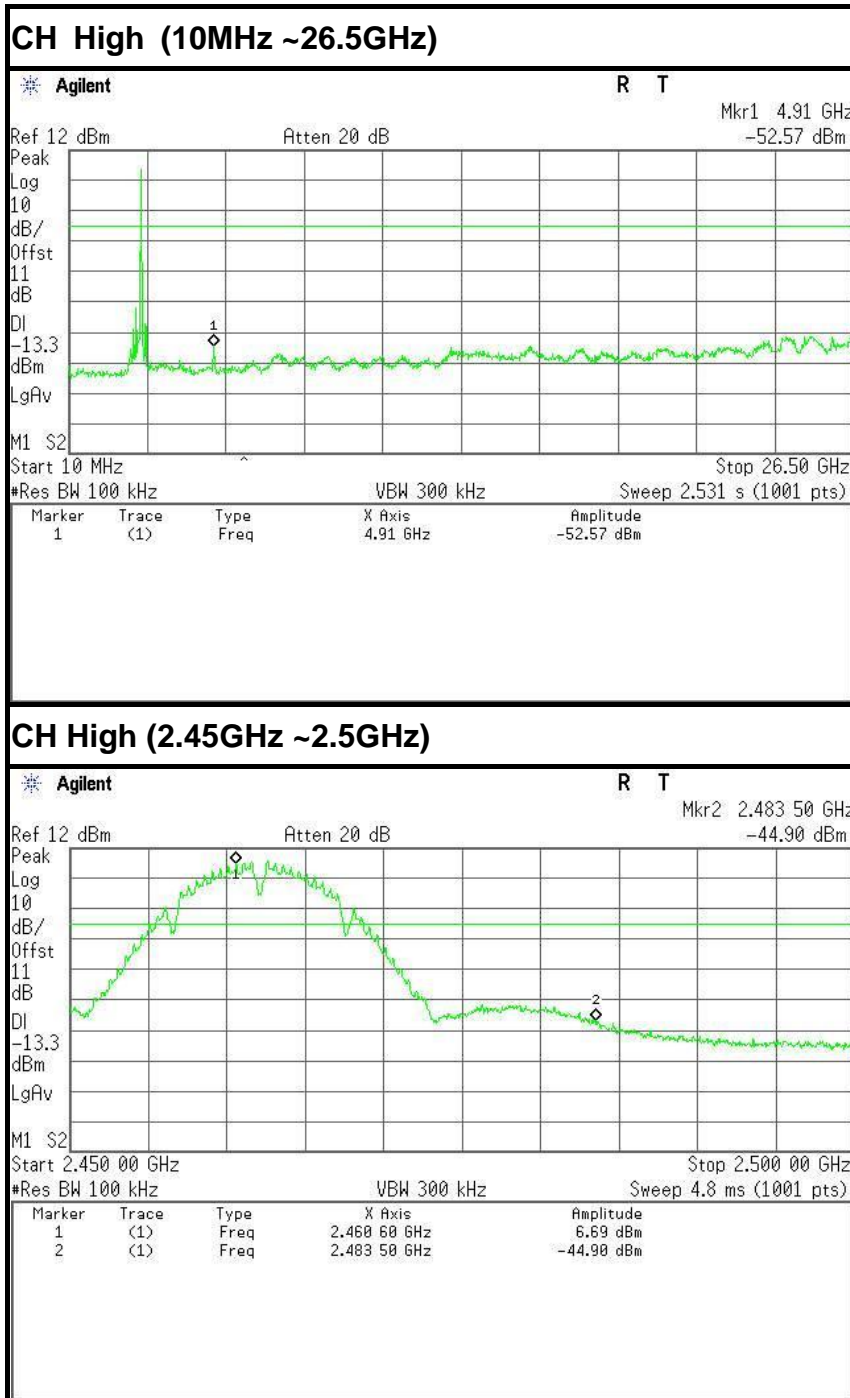



IEEE 802.11g mode

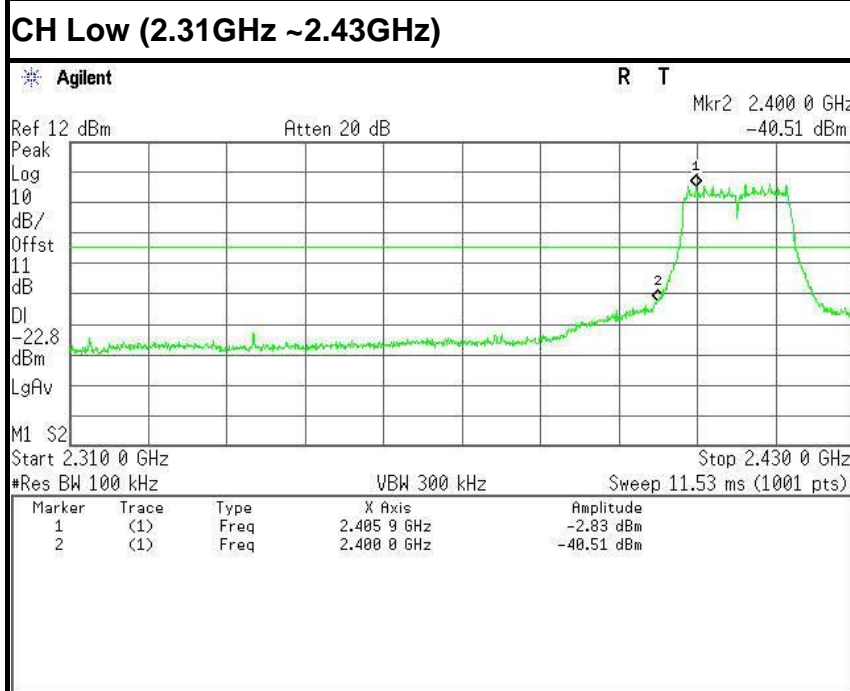
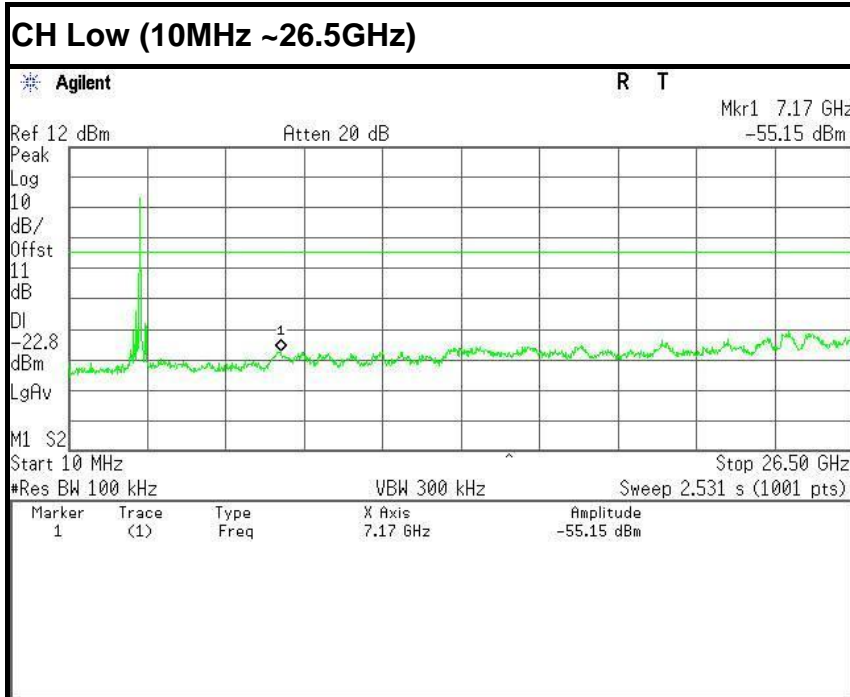

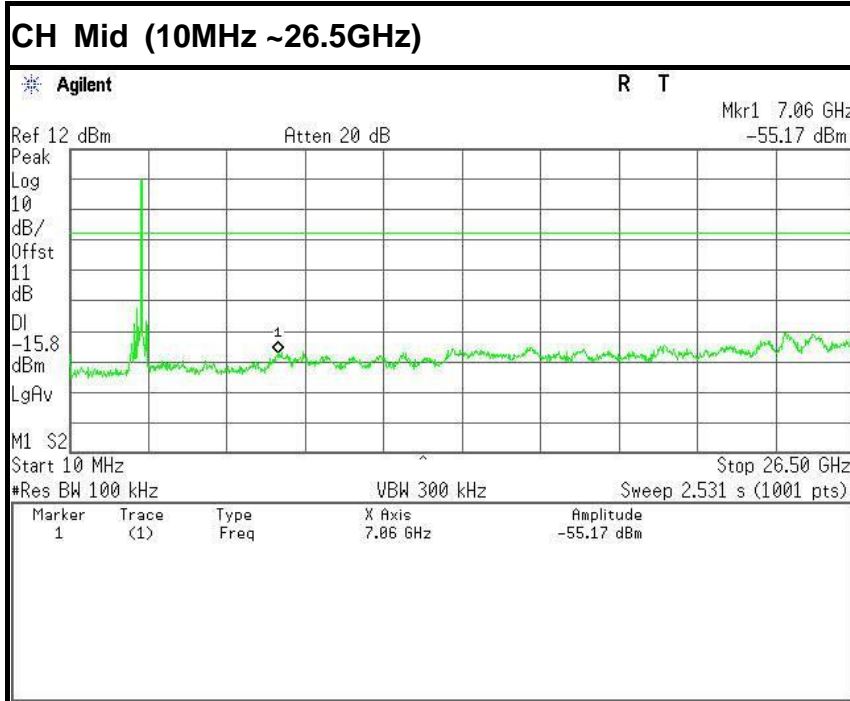

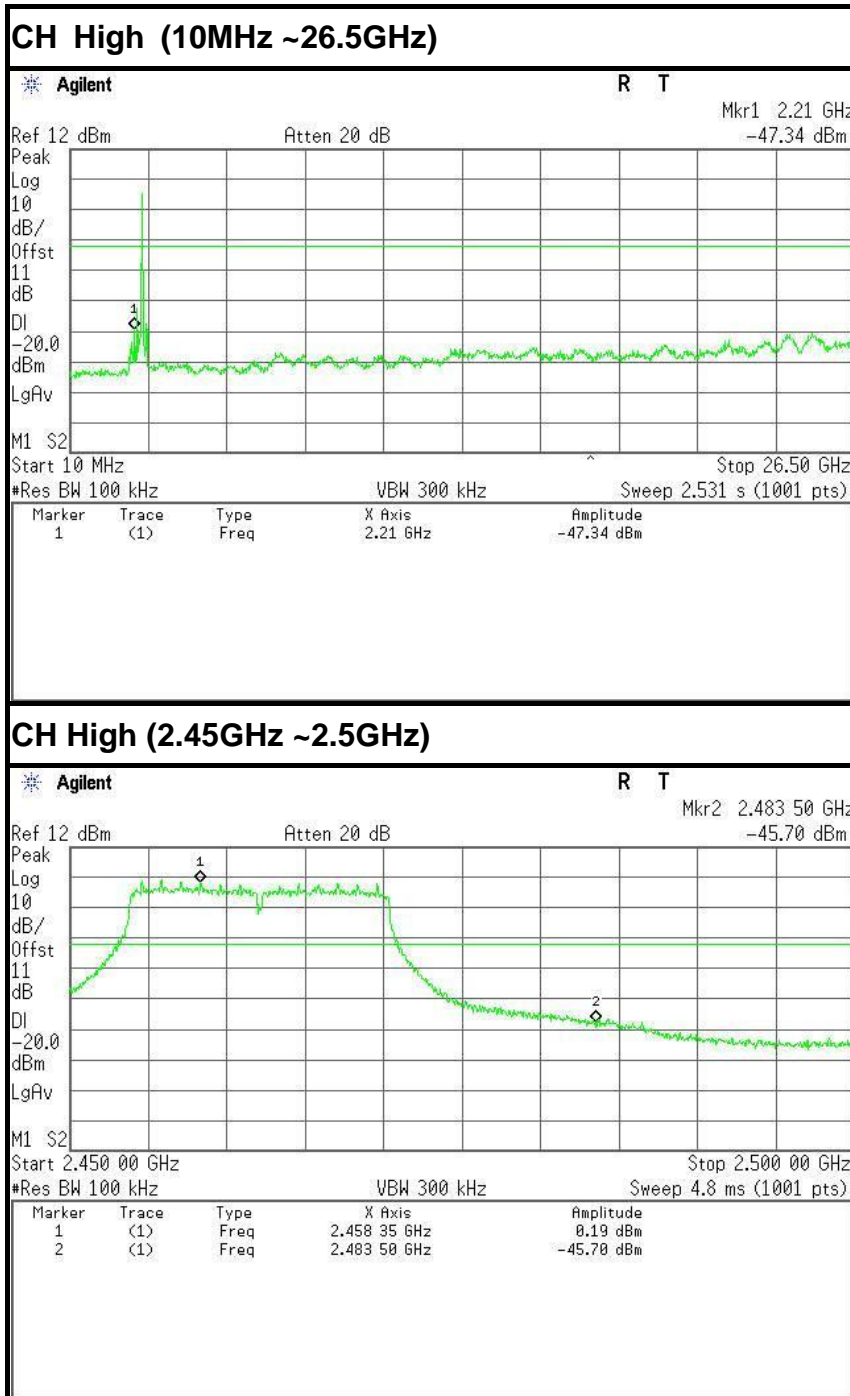



IEEE 802.11n HT20 MHz mode

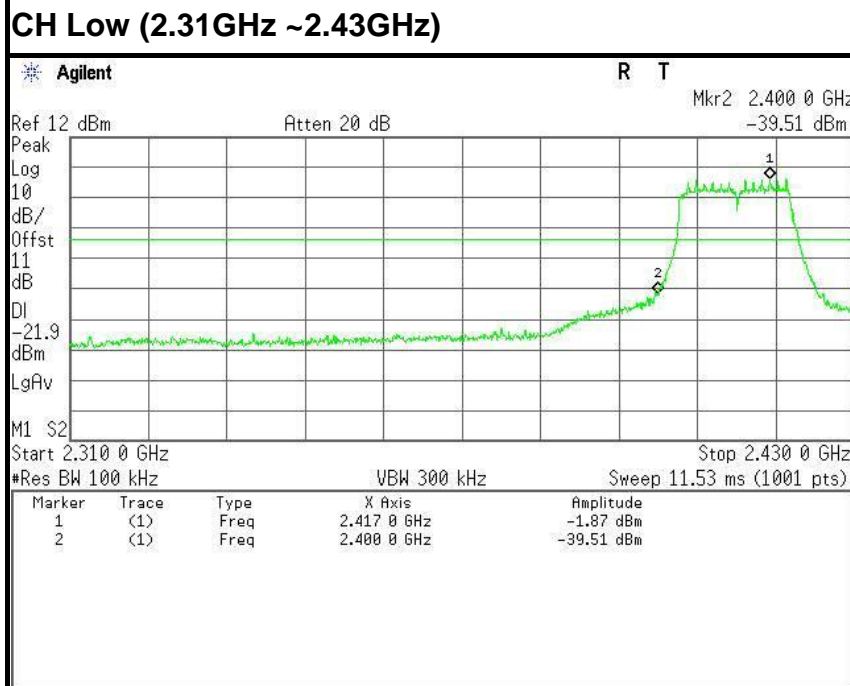
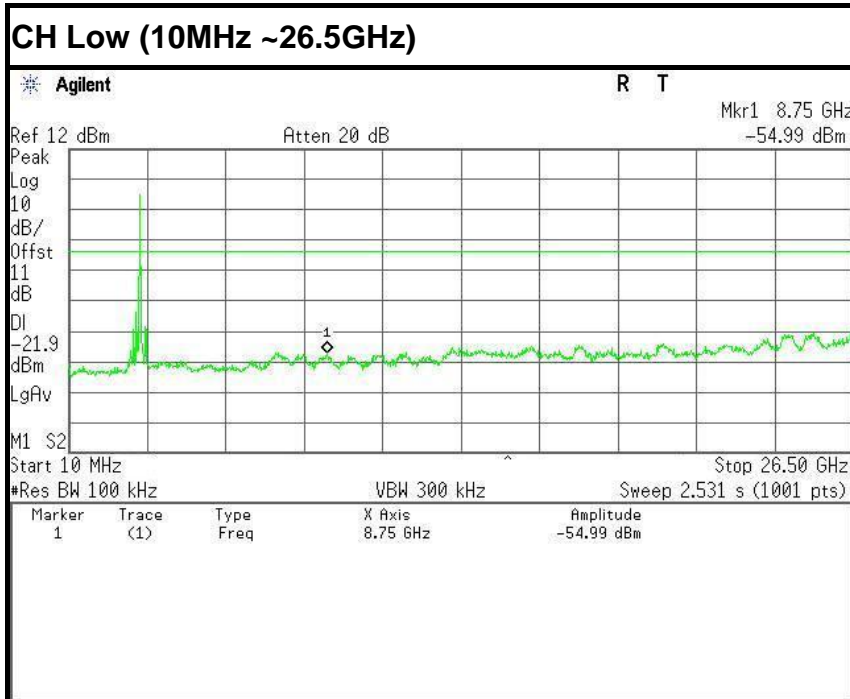

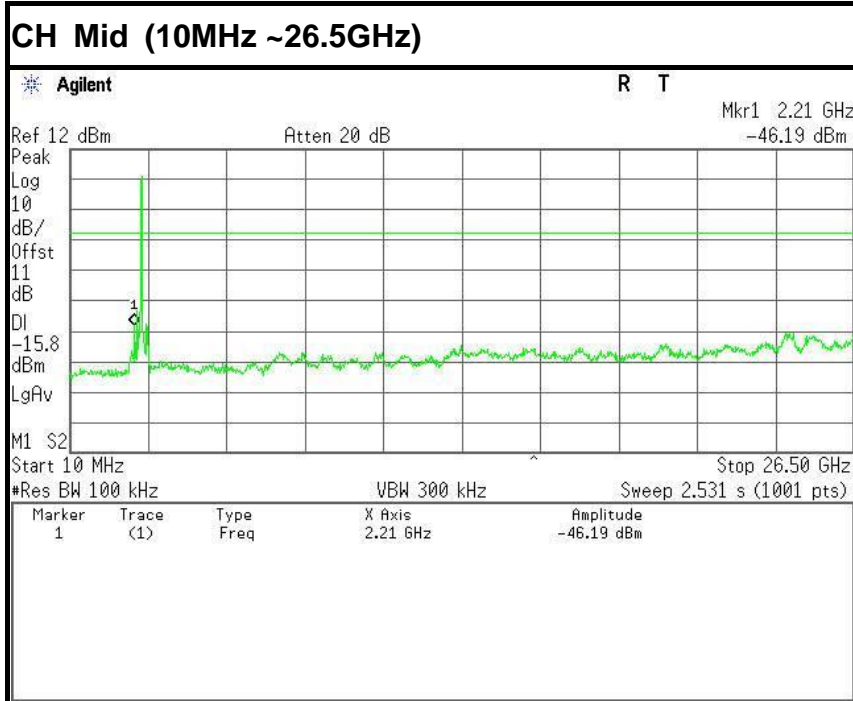

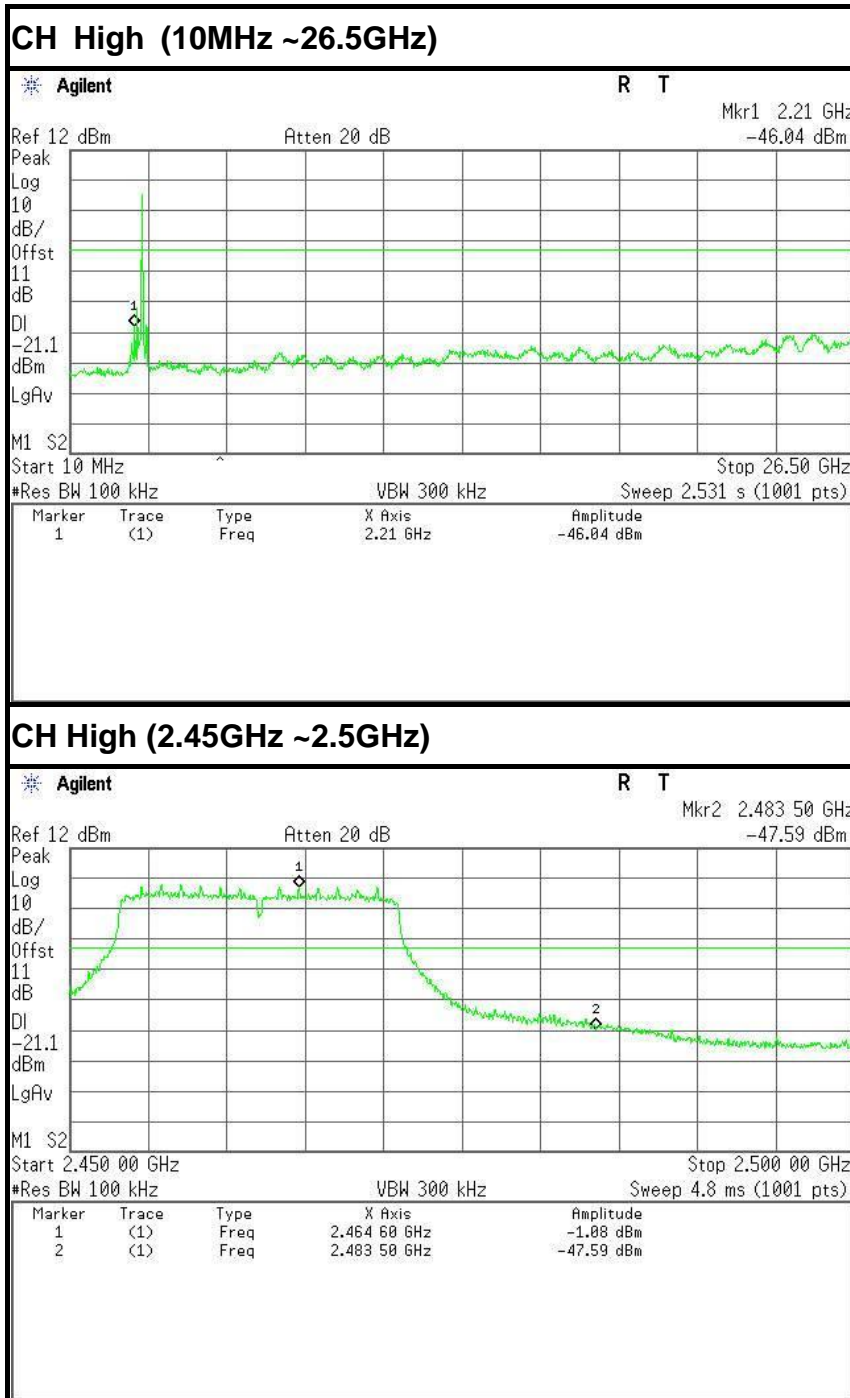



IEEE 802.11n HT40 MHz mode

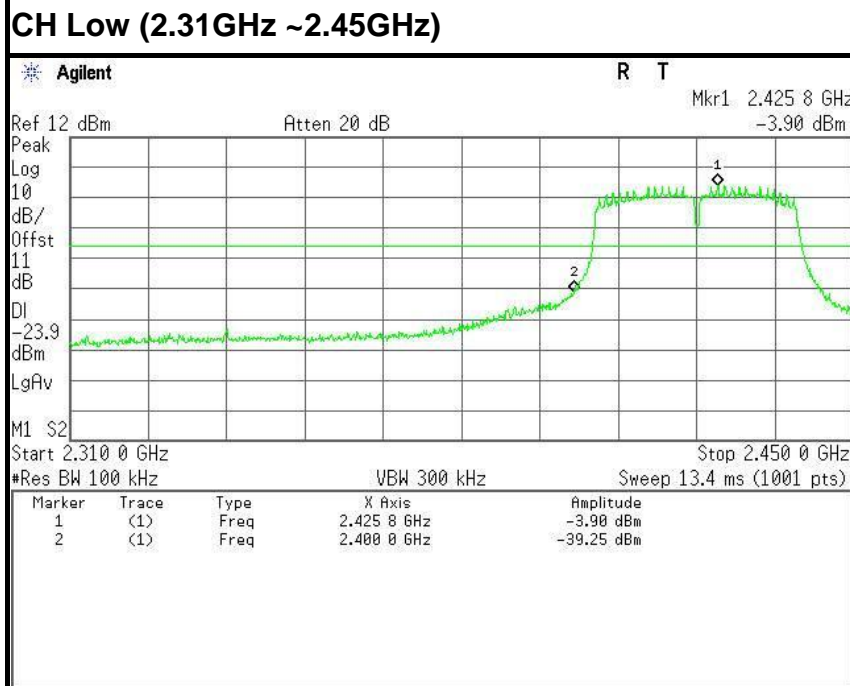
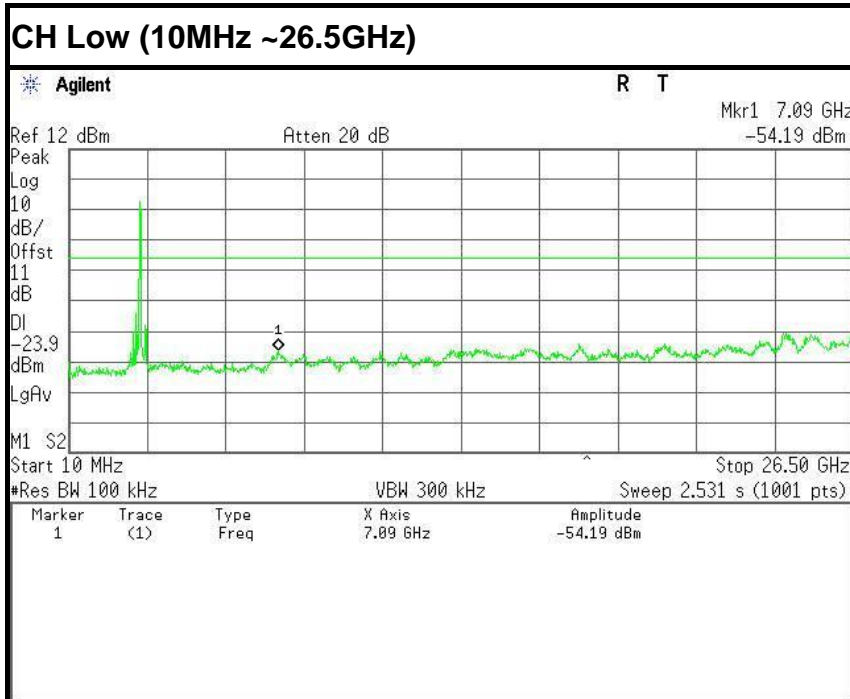

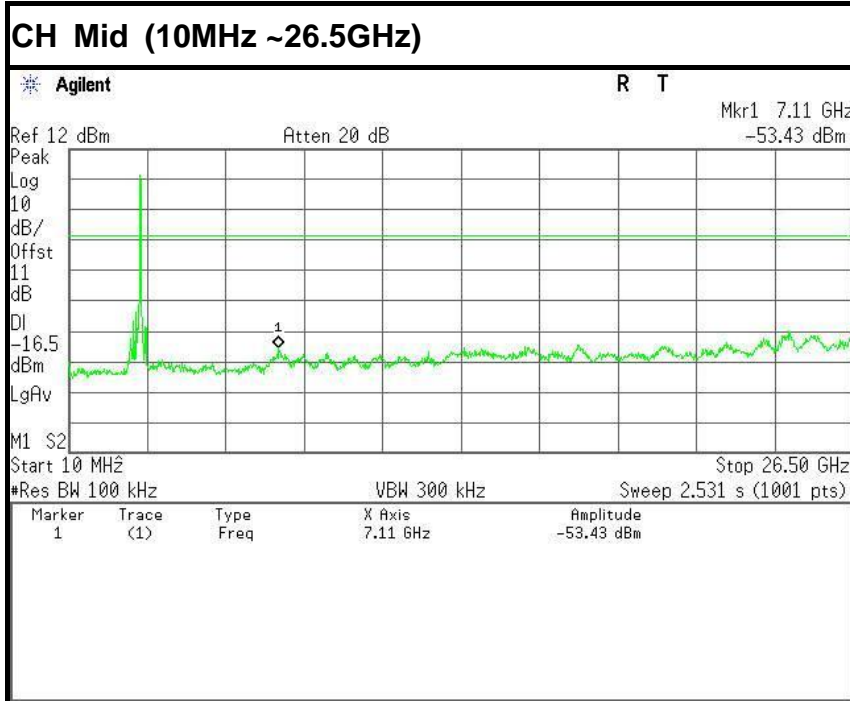

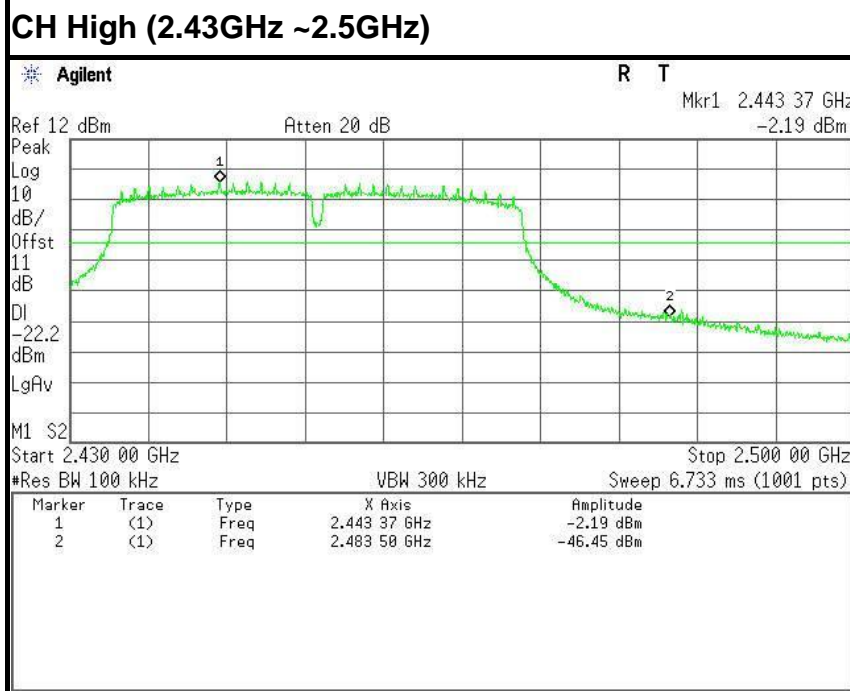
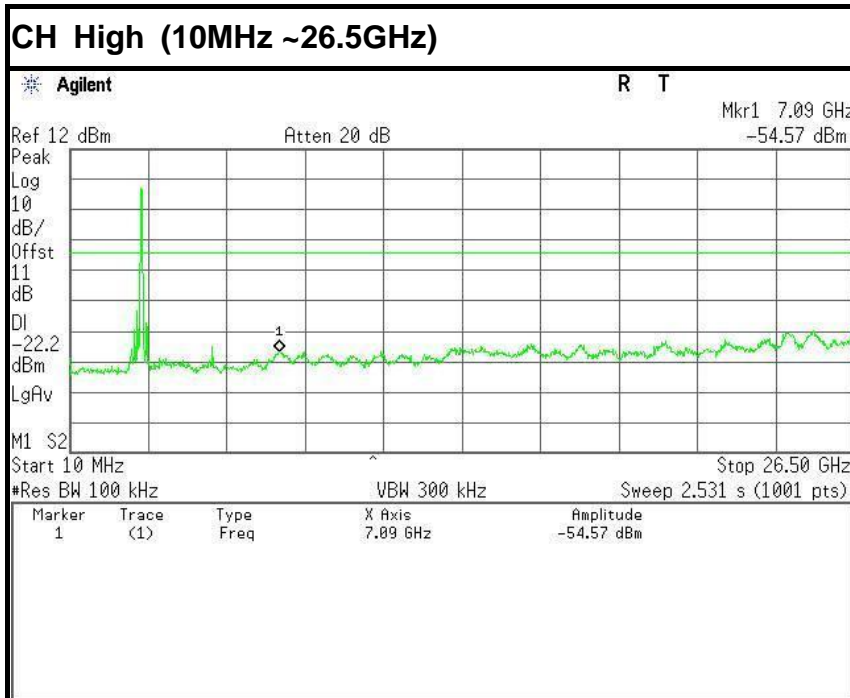



7.2.2. RADIATED EMISSIONS MEASUREMENT

7.2.2.1. LIMITS OF RADIATED EMISSIONS MEASUREMENT

According to §15.209(a), except as provided elsewhere in this Subpart, the emissions from an intentional radiator shall not exceed the field strength levels specified in the following table:

Frequency (MHz)	Field Strength (mV/m)	Measurement Distance (m)
0.009-0.490	2400/F(kHz)	300
0.490-1.705	24000/F(kHz)	30
1.705-30.0	30	30
30-88	100*	3
88-216	150*	3
216-960	200*	3
Above 960	500	3

Remark: Except as provided in paragraph (g), fundamental emissions from intentional radiators operating under this Section shall not be located in the frequency bands 54-72 MHz, 76-88 MHz, 174-216 MHz or 470-806 MHz. However, operation within these frequency bands is permitted under other sections of this Part, e.g., Sections 15.231 and 15.241.

1. In the emission table above, the tighter limit applies at the band edges.

Frequency (MHz)	Field Strength (µV/m at 3-meter)	Field Strength (dBµV/m at 3-meter)
30-88	100	40
88-216	150	43.5
216-960	200	46
Above 960	500	54

NOTE:(1) The lower limit shall apply at the transition frequencies.
(2) Emission level (dBuV/m) = 20 log Emission level (uV/m).

**7.2.2.2. TEST INSTRUMENTS**

Radiated Emission Test Site 966(2)					
Name of Equipment	Manufacturer	Model Number	Serial Number	Last Calibration	Due Calibration
PSA Series Spectrum Analyzer	Agilent	E4446A	US44300399	02/21/2016	02/20/2017
EMI TEST RECEIVER	ROHDE&SCHWARZ	ESCI	100783	02/21/2016	02/20/2017
Amplifier	MITEQ	AM-1604-3000	1123808	02/21/2016	02/20/2017
High Noise Amplifier	Agilent	8449B	3008A01838	02/21/2016	02/20/2017
Board-Band Horn Antenna	Schwarzbeck	BBHA 9170	9170-497	02/21/2016	02/20/2017
Bilog Antenna	SCHAFFNER	CBL6143	5082	02/21/2016	02/20/2017
Horn Antenna	SCHWARZBECK	BBHA9120	D286	02/21/2016	02/20/2017
Loop Antenna	COM-POWER	AL-130	121044	02/21/2016	02/20/2017
Turn Table	N/A	N/A	N/A	N.C.R	N.C.R
Controller	Sunol Sciences	SC104V	022310-1	N.C.R	N.C.R
Controller	CT	N/A	N/A	N.C.R	N.C.R
Temp. / Humidity Meter	Anymetre	JR913	N/A	02/21/2016	02/20/2017
Antenna Tower	SUNOL	TLT2	N/A	N.C.R	N.C.R
Test S/W	FARAD	LZ-RF / CCS-SZ-3A2			

- NOTE:** 1. The calibration interval of the above test instruments is 12 months and the calibrations are traceable to NML/ROC and NIST/USA.
2. The FCC Site Registration number is 101879.
3. N.C.R = No Calibration Required.



7.2.2.3. TEST PROCEDURE (please refer to measurement standard)

1. The EUT is placed on a turntable, which is 0.8m or 1.5m above ground plane.
2. The turntable shall be rotated for 360 degrees to determine the position of maximum emission level.
3. EUT is set 3m away from the receiving antenna, which is varied from 1m to 4m to find out the highest emissions.
4. Maximum procedure was performed on the six highest emissions to ensure EUT compliance.
5. And also, each emission was to be maximized by changing the polarization of receiving antenna both horizontal and vertical.
6. Set the spectrum analyzer in the following setting as:
 - Below 1GHz:
 - RBW=100kHz / VBW=300kHz / Sweep=AUTO
 - Above 1GHz:
 - (a) PEAK: RBW=1MHz,VBW=3MHz / Sweep=AUTO
 - (b) AVERAGE: RBW=1MHz / VBW=10Hz / Sweep=AUTO / Detector=Peak
7. Repeat above procedures until the measurements for all frequencies
8. are complete.



7.2.2.4. TEST SETUP

Below 30MHz

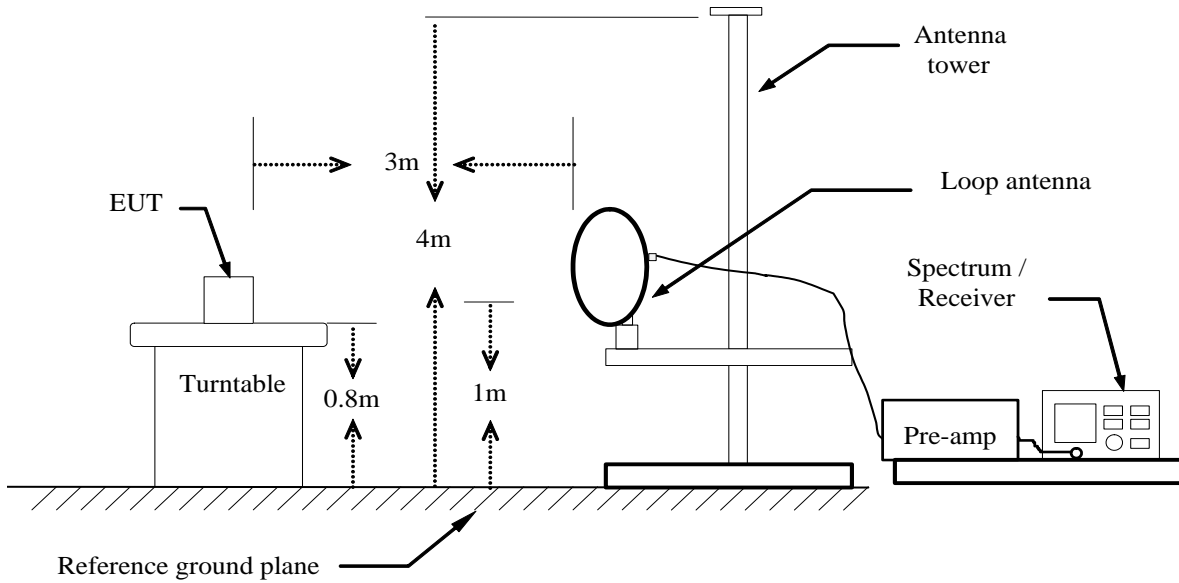

Below 1 GHz

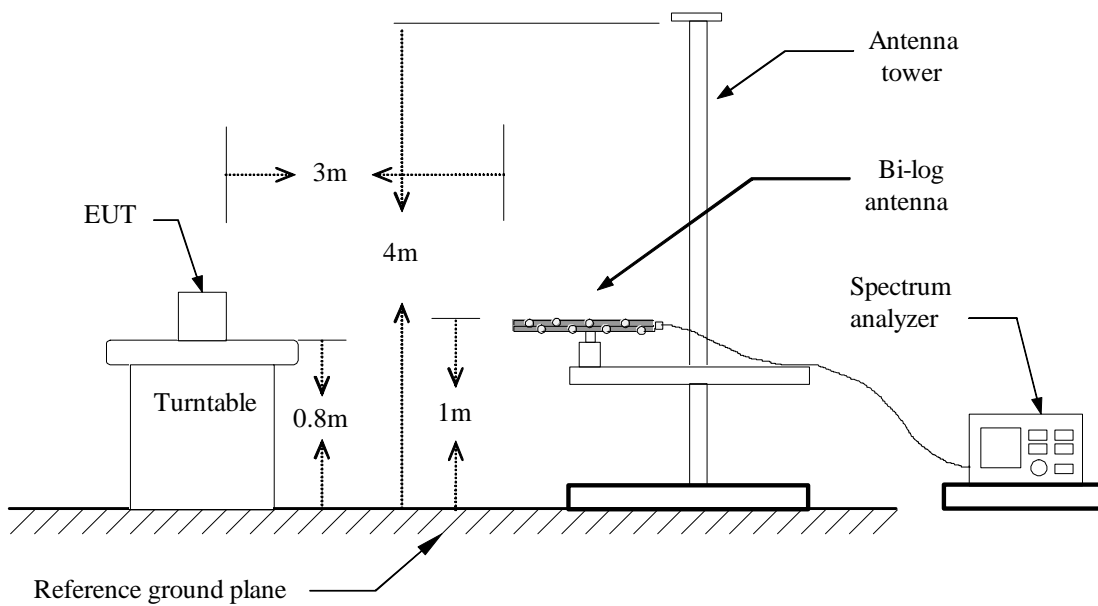



Above 1 GHz

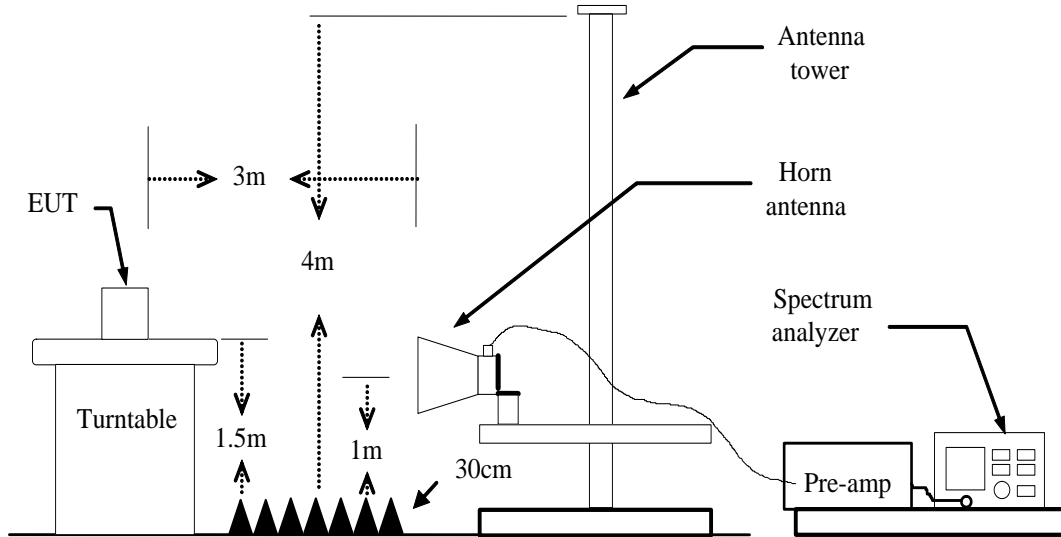

For the actual test configuration, please refer to the related item – Photographs of the Test Configuration.



7.2.2.5. DATA SAMPLE

Below 1GHz

Frequency (MHz)	Reading (dBuV)	Correct Factor (dB/m)	Result (dBuV/m)	Limit (dBuV/m)	Margin (dB)	Antenna Pole (V/H)	Remark
XXX.XXXX	36.37	-12.20	24.17	40.00	-15.83	V	QP

Frequency (MHz) = Emission frequency in MHz
 Reading (dBuV) = Uncorrected Analyzer / Receiver reading
 Correct Factor (dB/m) = Antenna factor + Cable loss – Amplifier gain
 Result (dBuV/m) = Reading (dBuV) + Corr. Factor (dB/m)
 Limit (dBuV/m) = Limit stated in standard
 Margin (dB) = Result (dBuV/m) – Limit (dBuV/m)
 Q.P. = Quasi-peak Reading

Above 1GHz

Frequency (MHz)	Reading (dBuV)	Correction Factor (dB/m)	Result (dBuV/m)	Limit (dBuV/m)	Margin (dB)	Antenna Pole (V/H)	Remark
XXXX.XXXX	62.09	-11.42	50.67	74.00	-23.33	V	Peak
XXXX.XXXX	49.78	-11.42	38.36	54.00	-15.64	V	AVG

Frequency (MHz) = Emission frequency in MHz
 Reading (dBuV) = Uncorrected Analyzer / Receiver reading
 Correction Factor (dB/m) = Antenna factor + Cable loss – Amplifier gain
 Result (dBuV/m) = Reading (dBuV) + Corr. Factor (dB/m)
 Limit (dBuV/m) = Limit stated in standard
 Margin (dB) = Result (dBuV/m) – Limit (dBuV/m)
 Peak = Peak Reading
 AVG = Average Reading

Calculation Formula

Margin (dB) = Result (dBuV/m) – Limits (dBuV/m)
 Result (dBuV/m) = Reading (dBuV) + Correction Factor



7.2.2.6. TEST RESULTS

Below 1 GHz

Test Mode: TX

Tested by: Jack Chen

Ambient temperature: 24°C **Relative humidity:** 52% RH

Date: March 22, 2016

Frequency (MHz)	Reading (dBuV)	Correction Factor (dB/m)	Result (dBuV/m)	Limit (dBuV/m)	Margin (dB)	Antenna Pole (V/H)	Remark
91.4333	58.63	-24.59	34.04	43.50	-9.46	V	QP
243.4000	51.52	-21.36	30.16	46.00	-15.84	V	QP
555.4166	42.78	-13.19	29.59	46.00	-16.41	V	QP
626.5500	46.35	-12.65	33.70	46.00	-12.30	V	QP
712.2332	42.59	-11.89	30.70	46.00	-15.30	V	QP
859.3500	42.72	-10.63	32.09	46.00	-13.91	V	QP
75.2667	58.53	-26.22	32.31	40.00	-7.69	H	QP
86.5832	56.14	-25.40	30.74	40.00	-9.26	H	QP
207.8333	55.80	-21.77	34.03	43.50	-9.47	H	QP
228.8500	53.84	-21.68	32.16	46.00	-13.84	H	QP
524.7000	43.37	-14.02	29.35	46.00	-16.65	H	QP
814.0833	40.08	-10.61	29.47	46.00	-16.53	H	QP

****Remark:** No emission found between lowest internal used/generated frequency to 30MHz.

Notes:

1. Radiated emissions measured in frequency range from 9kHz to 1GHz were made with an instrument using Quasi-peak detector mode.
2. Data of measurement within this frequency range shown " --- " in the table above means the reading of emissions are attenuated more than 20dB below the permissible limits or the field strength is too small to be measured.
3. The IF bandwidth of Receiver between 30MHz to 1GHz was 120kHz.
4. Frequency (MHz). = Emission frequency in MHz
 Reading (dBuV/m) = Receiver reading
 Correction Factor (dB) = Antenna factor + Cable loss – Amplifier gain
 Limit (dBuV/m) = Limit stated in standard
 Margin (dB) = Measured (dBuV/m) – Limits (dBuV/m)
 Antenna Pole (H/V) = Current carrying line of reading



Above 1 GHz

Test Mode: TX / IEEE 802.11b(CH Low)

Tested by: Jack Chen

Ambient temperature: 24°C **Relative humidity:** 52% RH

Date: March 29, 2016

Frequency (MHz)	Reading (dBuV)	Correction Factor (dB/m)	Result (dBuV/m)	Limit (dBuV/m)	Margin (dB)	Antenna Pole (V/H)	Remark
1000.0000	54.64	-9.36	45.28	74.00	-28.72	V	peak
1198.000	51.46	-7.80	43.66	74.00	-30.34	V	peak
1765.000	49.88	-6.35	43.53	74.00	-30.47	V	peak
2197.000	51.56	-3.92	47.64	74.00	-26.36	V	peak
4825.000	50.86	4.41	55.27	74.00	-18.73	V	peak
4825.000	46.12	4.41	50.53	54.00	-3.47	V	AVG
7741.000	40.29	9.14	49.43	74.00	-24.57	V	peak
1000.0000	57.63	-9.36	48.27	74.00	-25.73	H	Peak
1747.000	54.63	-6.38	48.25	74.00	-25.75	H	Peak
4825.000	50.88	4.41	55.29	74.00	-18.71	H	Peak
4825.000	46.02	4.41	50.43	54.00	-3.57	H	AVG
6805.000	41.25	7.38	48.63	74.00	-25.37	H	peak
8218.000	40.59	9.53	50.12	74.00	-23.88	H	peak
9235.000	41.64	9.78	51.42	74.00	-22.58	H	peak

REMARKS:

1. *Measuring frequencies from 1 GHz to the 10th harmonic of highest fundamental frequency.*
2. *Radiated emissions measured in frequency above 1000MHz were made with an instrument using peak/average detector mode.*
3. *Average test would be performed if the peak result were greater than the average limit or as required by the applicant.*
4. *Data of measurement within this frequency range shown “ --- ” in the table above means the reading of emissions are attenuated more than 20dB below the permissible limits or the field strength is too small to be measured.*
5. *Measurements above show only up to 6 maximum emissions noted, or would be lesser, with “ N/A ” remark, if no specific emissions from the EUT are recorded (ie: margin>20dB from the applicable limit) and considered that's already beyond the background noise floor.*
6. *Margin (dB) = Remark result (dBuV/m) – Average limit (dBuV/m).*



Test Mode: TX / IEEE 802.11b (CH Mid)

Tested by: Jack Chen

Ambient temperature: 24°C Relative humidity: 52% RH

Date: March 29, 2016

Frequency (MHz)	Reading (dBuV)	Correction Factor (dB/m)	Result (dBuV/m)	Limit (dBuV/m)	Margin (dB)	Antenna Pole (V/H)	Remark
1000.0000	57.43	-9.36	48.07	74.00	-25.93	V	Peak
1198.000	53.35	-7.80	45.55	74.00	-28.45	V	Peak
2197.000	52.54	-3.92	48.62	74.00	-25.38	V	Peak
4141.000	43.25	2.09	45.34	74.00	-28.66	V	Peak
4870.000	50.61	4.56	55.17	74.00	-18.83	V	Peak
4870.000	45.68	4.56	50.24	54.00	-3.76	V	AVG
6346.000	40.46	6.64	47.10	74.00	-26.90	V	Peak
1198.000	53.51	-7.80	45.71	74.00	-28.29	H	Peak
1801.000	52.14	-6.26	45.88	74.00	-28.12	H	Peak
2197.000	48.33	-3.92	44.41	74.00	-29.59	H	Peak
4870.000	49.61	4.56	54.17	74.00	-19.83	H	Peak
4870.000	46.76	4.56	51.32	54.00	-2.68	H	AVG
5833.000	40.08	6.01	46.09	74.00	-27.91	H	Peak
6967.000	40.13	7.65	47.78	74.00	-26.22	H	Peak

REMARKS:

1. Measuring frequencies from 1 GHz to the 10th harmonic of highest fundamental frequency.
2. Radiated emissions measured in frequency above 1000MHz were made with an instrument using peak/average detector mode.
3. Average test would be performed if the peak result were greater than the average limit or as required by the applicant.
4. Data of measurement within this frequency range shown “ --- ” in the table above means the reading of emissions are attenuated more than 20dB below the permissible limits or the field strength is too small to be measured.
5. Measurements above show only up to 6 maximum emissions noted, or would be lesser, with “ N/A ” remark, if no specific emissions from the EUT are recorded (ie: margin>20dB from the applicable limit) and considered that's already beyond the background noise floor.
6. Margin (dB) = Remark result (dBuV/m) – Average limit (dBuV/m).



Test Mode: TX / IEEE 802.11b (CH High)

Tested by: Jack Chen

Ambient temperature: 24°C Relative humidity: 52% RH

Date: March 29, 2016

Frequency (MHz)	Reading (dBuV)	Correction Factor (dB/m)	Result (dBuV/m)	Limit (dBuV/m)	Margin (dB)	Antenna Pole (V/H)	Remark
1000.0000	57.20	-9.36	47.84	74.00	-26.16	V	Peak
1801.000	51.05	-6.26	44.79	74.00	-29.21	V	Peak
2197.000	51.09	-3.92	47.17	74.00	-26.83	V	Peak
4942.000	48.57	4.79	53.36	74.00	-20.64	V	Peak
4942.000	44.26	4.79	49.05	54.00	-4.95	V	AVG
6562.000	40.22	6.99	47.21	74.00	-26.79	V	Peak
7768.000	40.15	9.20	49.35	74.00	-24.65	V	Peak
1198.000	52.76	-7.80	44.96	74.00	-29.04	H	Peak
1801.000	52.16	-6.26	45.90	74.00	-28.10	H	Peak
2197.000	49.03	-3.92	45.11	74.00	-28.89	H	Peak
4942.000	46.35	4.79	51.14	74.00	-22.86	H	Peak
6022.000	40.02	6.12	46.14	74.00	-27.86	H	Peak
7750.000	40.55	9.16	49.71	74.00	-24.29	H	Peak

REMARKS:

1. Measuring frequencies from 1 GHz to the 10th harmonic of highest fundamental frequency.
2. Radiated emissions measured in frequency above 1000MHz were made with an instrument using peak/average detector mode.
3. Average test would be performed if the peak result were greater than the average limit or as required by the applicant.
4. Data of measurement within this frequency range shown " --- " in the table above means the reading of emissions are attenuated more than 20dB below the permissible limits or the field strength is too small to be measured.
5. Measurements above show only up to 6 maximum emissions noted, or would be lesser, with " N/A " remark, if no specific emissions from the EUT are recorded (ie: margin>20dB from the applicable limit) and considered that's already beyond the background noise floor.
6. Margin (dB) = Remark result (dBuV/m) – Average limit (dBuV/m).



Test Mode: TX / IEEE 802.11g(CH Low)

Tested by: Jack Chen

Ambient temperature: 24°C Relative humidity: 52% RH

Date: March 29, 2016

Frequency (MHz)	Reading (dBuV)	Correction Factor (dB/m)	Result (dBuV/m)	Limit (dBuV/m)	Margin (dB)	Antenna Pole (V/H)	Remark
1198.000	52.84	-7.80	45.04	74.00	-28.96	V	Peak
1747.000	56.06	-6.38	49.68	74.00	-24.32	V	Peak
2197.000	51.50	-3.92	47.58	74.00	-26.42	V	Peak
4825.000	49.27	4.41	53.68	74.00	-20.32	V	Peak
4825.000	36.81	4.41	41.22	54.00	-12.78	V	AVG
7219.000	40.47	8.13	48.60	74.00	-25.40	V	Peak
7795.000	39.85	9.25	49.10	74.00	-24.90	V	Peak
1000.0000	57.62	-9.36	48.26	74.00	-25.74	H	Peak
1198.000	55.75	-7.80	47.95	74.00	-26.05	H	Peak
1747.000	52.96	-6.38	46.58	74.00	-27.42	H	Peak
3214.000	43.23	-1.00	42.23	74.00	-31.77	H	Peak
4168.000	42.55	2.18	44.73	74.00	-29.27	H	Peak
4816.000	48.98	4.38	53.36	74.00	-20.64	H	Peak
4816.000	36.95	4.38	41.33	54.00	-12.67	H	AVG

REMARKS:

1. Measuring frequencies from 1 GHz to the 10th harmonic of highest fundamental frequency.
2. Radiated emissions measured in frequency above 1000MHz were made with an instrument using peak/average detector mode.
3. Average test would be performed if the peak result were greater than the average limit or as required by the applicant.
4. Data of measurement within this frequency range shown “ --- ” in the table above means the reading of emissions are attenuated more than 20dB below the permissible limits or the field strength is too small to be measured.
5. Measurements above show only up to 6 maximum emissions noted, or would be lesser, with “ N/A ” remark, if no specific emissions from the EUT are recorded (ie: margin>20dB from the applicable limit) and considered that's already beyond the background noise floor.
6. Margin (dB) = Remark result (dBuV/m) – Average limit (dBuV/m).



Test Mode: TX / IEEE 802.11g (CH Mid)

Tested by: Jack Chen

Ambient temperature: 24°C Relative humidity: 52% RH

Date: March 29, 2016

Frequency (MHz)	Reading (dBuV)	Correction Factor (dB/m)	Result (dBuV/m)	Limit (dBuV/m)	Margin (dB)	Antenna Pole (V/H)	Remark
1765.000	52.66	-6.35	46.31	74.00	-27.69	V	Peak
2197.000	55.18	-3.92	51.26	74.00	-22.74	V	Peak
3250.000	43.92	-0.94	42.98	74.00	-31.02	V	Peak
4879.000	50.47	4.59	55.06	74.00	-18.94	V	Peak
4879.000	38.68	4.59	43.27	54.00	-10.73	V	AVG
5302.000	38.93	5.52	44.45	74.00	-29.55	V	Peak
7309.000	41.00	8.30	49.30	74.00	-24.70	V	Peak
1198.000	56.75	-7.80	48.95	74.00	-25.05	H	Peak
1198.000	56.75	-7.80	48.95	74.00	-25.05	H	Peak
1747.000	56.13	-6.38	49.75	74.00	-24.25	H	Peak
3250.000	43.75	-0.94	42.81	74.00	-31.19	H	Peak
4870.000	47.61	4.56	52.17	74.00	-21.83	H	Peak
4870.000	37.10	4.56	41.66	54.00	-12.34	H	AVG
6823.000	40.07	7.41	47.48	74.00	-26.52	H	Peak

REMARKS:

1. Measuring frequencies from 1 GHz to the 10th harmonic of highest fundamental frequency.
2. Radiated emissions measured in frequency above 1000MHz were made with an instrument using peak/average detector mode.
3. Average test would be performed if the peak result were greater than the average limit or as required by the applicant.
4. Data of measurement within this frequency range shown " --- " in the table above means the reading of emissions are attenuated more than 20dB below the permissible limits or the field strength is too small to be measured.
5. Measurements above show only up to 6 maximum emissions noted, or would be lesser, with " N/A " remark, if no specific emissions from the EUT are recorded (ie: margin>20dB from the applicable limit) and considered that's already beyond the background noise floor.
6. Margin (dB) = Remark result (dBuV/m) – Average limit (dBuV/m).



Test Mode: TX / IEEE 802.11g (CH High)

Tested by: Jack Chen

Ambient temperature: 24°C Relative humidity: 52% RH

Date: March 29, 2016

Frequency (MHz)	Reading (dBuV)	Correction Factor (dB/m)	Result (dBuV/m)	Limit (dBuV/m)	Margin (dB)	Antenna Pole (V/H)	Remark
2053.000	50.94	-4.71	46.23	74.00	-27.77	V	Peak
2197.000	53.79	-3.92	49.87	74.00	-24.13	V	Peak
4006.000	41.45	1.61	43.06	74.00	-30.94	V	Peak
4942.000	46.94	4.79	51.73	74.00	-22.27	V	Peak
6823.000	40.50	7.41	47.91	74.00	-26.09	V	Peak
7759.000	40.99	9.18	50.17	74.00	-23.83	V	Peak
1747.000	58.37	-6.38	51.99	74.00	-22.01	H	Peak
2197.000	49.77	-3.92	45.85	74.00	-28.15	H	Peak
4942.000	46.99	4.79	51.78	74.00	-22.22	H	Peak
6940.000	40.49	7.60	48.09	74.00	-25.91	H	Peak
7795.000	41.01	9.25	50.26	74.00	-23.74	H	Peak
8263.000	40.84	9.51	50.35	74.00	-23.65	H	Peak

REMARKS:

1. Measuring frequencies from 1 GHz to the 10th harmonic of highest fundamental frequency.
2. Radiated emissions measured in frequency above 1000MHz were made with an instrument using peak/average detector mode.
3. Average test would be performed if the peak result were greater than the average limit or as required by the applicant.
4. Data of measurement within this frequency range shown " --- " in the table above means the reading of emissions are attenuated more than 20dB below the permissible limits or the field strength is too small to be measured.
5. Measurements above show only up to 6 maximum emissions noted, or would be lesser, with " N/A " remark, if no specific emissions from the EUT are recorded (ie: margin>20dB from the applicable limit) and considered that's already beyond the background noise floor.
6. Margin (dB) = Remark result (dBuV/m) – Average limit (dBuV/m).



Test Mode: TX / IEEE 802.11n HT20 MHz (CH Low)

Tested by: Jack Chen

Ambient temperature: 24°C Relative humidity: 52% RH

Date: March 29, 2016

Frequency (MHz)	Reading (dBuV)	Correction Factor (dB/m)	Result (dBuV/m)	Limit (dBuV/m)	Margin (dB)	Antenna Pole (V/H)	Remark
1747.000	56.64	-6.38	50.26	74.00	-23.74	V	Peak
2197.000	52.01	-3.92	48.09	74.00	-25.91	V	Peak
3214.000	44.19	-1.00	43.19	74.00	-30.81	V	Peak
4825.000	48.78	4.41	53.19	74.00	-20.81	V	Peak
4825.000	37.24	4.41	41.65	54.00	-12.35	V	AVG
6949.000	40.69	7.62	48.31	74.00	-25.69	V	Peak
7876.000	41.14	9.41	50.55	74.00	-23.45	V	Peak
1747.000	51.77	-6.38	45.39	74.00	-28.61	H	Peak
2197.000	50.76	-3.92	46.84	74.00	-27.16	H	Peak
4816.000	48.19	4.38	52.57	74.00	-21.43	H	Peak
4816.000	36.28	4.38	40.66	54.00	-13.34	H	AVG
5968.000	39.34	6.07	45.41	74.00	-28.59	H	Peak
7237.000	39.82	8.16	47.98	74.00	-26.02	H	Peak
7939.000	40.24	9.53	49.77	74.00	-24.23	H	Peak

REMARKS:

1. *Measuring frequencies from 1 GHz to the 10th harmonic of highest fundamental frequency.*
2. *Radiated emissions measured in frequency above 1000MHz were made with an instrument using peak/average detector mode.*
3. *Average test would be performed if the peak result were greater than the average limit or as required by the applicant.*
4. *Data of measurement within this frequency range shown " --- " in the table above means the reading of emissions are attenuated more than 20dB below the permissible limits or the field strength is too small to be measured.*
5. *Measurements above show only up to 6 maximum emissions noted, or would be lesser, with " N/A " remark, if no specific emissions from the EUT are recorded (ie: margin>20dB from the applicable limit) and considered that's already beyond the background noise floor.*
6. *Margin (dB) = Remark result (dBuV/m) – Average limit (dBuV/m).*



Test Mode: TX / IEEE 802.11n HT20 MHz (CH Mid)

Tested by: Jack Chen

Ambient temperature: 24°C Relative humidity: 52% RH

Date: March 29, 2016

Frequency (MHz)	Reading (dBuV)	Correction Factor (dB/m)	Result (dBuV/m)	Limit (dBuV/m)	Margin (dB)	Antenna Pole (V/H)	Remark
1198.000	54.68	-7.80	46.88	74.00	-27.12	V	Peak
1747.000	53.12	-6.38	46.74	74.00	-27.26	V	Peak
3367.000	42.42	-0.74	41.68	74.00	-32.32	V	Peak
4870.000	47.69	4.56	52.25	74.00	-21.75	V	Peak
4870.000	36.66	4.56	41.22	54.00	-12.78	V	AVG
6454.000	40.37	6.82	47.19	74.00	-26.81	V	Peak
7786.000	40.25	9.23	49.48	74.00	-24.52	V	Peak
2053.000	52.45	-4.71	47.74	74.00	-26.26	H	Peak
2197.000	54.47	-3.92	50.55	74.00	-23.45	H	Peak
3439.000	41.91	-0.62	41.29	74.00	-32.71	H	Peak
4870.000	49.92	4.56	54.48	74.00	-19.52	H	Peak
4870.000	37.77	4.56	42.33	54.00	-11.67	H	AVG
5734.000	39.24	5.97	45.21	74.00	-28.79	H	Peak
6940.000	40.35	7.60	47.95	74.00	-26.05	H	Peak

REMARKS:

1. *Measuring frequencies from 1 GHz to the 10th harmonic of highest fundamental frequency.*
2. *Radiated emissions measured in frequency above 1000MHz were made with an instrument using peak/average detector mode.*
3. *Average test would be performed if the peak result were greater than the average limit or as required by the applicant.*
4. *Data of measurement within this frequency range shown “ --- ” in the table above means the reading of emissions are attenuated more than 20dB below the permissible limits or the field strength is too small to be measured.*
5. *Measurements above show only up to 6 maximum emissions noted, or would be lesser, with “ N/A ” remark, if no specific emissions from the EUT are recorded (ie: margin>20dB from the applicable limit) and considered that's already beyond the background noise floor.*
6. *Margin (dB) = Remark result (dBuV/m) – Average limit (dBuV/m).*



Test Mode: TX / EEE 802.11n HT20 MHz (CH High)

Tested by: Jack Chen

Ambient temperature: 24°C Relative humidity: 52% RH

Date: March 29, 2016

Frequency (MHz)	Reading (dBUV)	Correction Factor (dB/m)	Result (dBUV/m)	Limit (dBUV/m)	Margin (dB)	Antenna Pole (V/H)	Remark
2053.000	50.73	-4.71	46.02	74.00	-27.98	V	Peak
3286.000	45.49	-0.88	44.61	74.00	-29.39	V	Peak
4924.000	46.00	4.73	50.73	74.00	-23.27	V	Peak
6832.000	40.05	7.43	47.48	74.00	-26.52	V	Peak
7723.000	40.26	9.11	49.37	74.00	-24.63	V	Peak
8326.000	41.28	9.47	50.75	74.00	-23.25	V	Peak
1198.000	55.36	-7.80	47.56	74.00	-26.44	H	Peak
1801.000	51.04	-6.26	44.78	74.00	-29.22	H	Peak
2197.000	50.48	-3.92	46.56	74.00	-27.44	H	Peak
4924.000	47.40	4.73	52.13	74.00	-21.87	H	Peak
4924.000	38.82	4.73	43.55	54.00	-10.45	H	AVG
6733.000	38.71	7.27	45.98	74.00	-28.02	H	Peak
7534.000	40.74	8.74	49.48	74.00	-24.52	H	Peak

REMARKS:

1. Measuring frequencies from 1 GHz to the 10th harmonic of highest fundamental frequency.
2. Radiated emissions measured in frequency above 1000MHz were made with an instrument using peak/average detector mode.
3. Average test would be performed if the peak result were greater than the average limit or as required by the applicant.
4. Data of measurement within this frequency range shown " --- " in the table above means the reading of emissions are attenuated more than 20dB below the permissible limits or the field strength is too small to be measured.
5. Measurements above show only up to 6 maximum emissions noted, or would be lesser, with " N/A " remark, if no specific emissions from the EUT are recorded (ie: margin>20dB from the applicable limit) and considered that's already beyond the background noise floor.
6. Margin (dB) = Remark result (dBUV/m) – Average limit (dBUV/m).



Test Mode: TX/ IEEE 802.11n HT40 MHz (CH Low)

Tested by: Jack Chen

Ambient temperature: 24°C Relative humidity: 52% RH

Date: March 29, 2016

Frequency (MHz)	Reading (dBuV)	Correction Factor (dB/m)	Result (dBuV/m)	Limit (dBuV/m)	Margin (dB)	Antenna Pole (V/H)	Remark
1198.000	54.23	-7.80	46.43	74.00	-27.57	V	Peak
1801.000	51.17	-6.26	44.91	74.00	-29.09	V	Peak
2197.000	51.04	-3.92	47.12	74.00	-26.88	V	Peak
4834.000	45.90	4.44	50.34	74.00	-23.66	V	Peak
6841.000	41.01	7.44	48.45	74.00	-25.55	V	Peak
8344.000	41.46	9.46	50.92	74.00	-23.08	V	Peak
1198.000	55.38	-7.80	47.58	74.00	-26.42	H	Peak
2197.000	48.31	-3.92	44.39	74.00	-29.61	H	Peak
4843.000	44.36	4.47	48.83	74.00	-25.17	H	Peak
5995.000	39.55	6.08	45.63	74.00	-28.37	H	Peak
6985.000	40.22	7.68	47.90	74.00	-26.10	H	Peak
7948.000	40.22	9.55	49.77	74.00	-24.23	H	Peak

REMARKS:

1. Measuring frequencies from 1 GHz to the 10th harmonic of highest fundamental frequency.
2. Radiated emissions measured in frequency above 1000MHz were made with an instrument using peak/average detector mode.
3. Average test would be performed if the peak result were greater than the average limit or as required by the applicant.
4. Data of measurement within this frequency range shown " --- " in the table above means the reading of emissions are attenuated more than 20dB below the permissible limits or the field strength is too small to be measured.
5. Measurements above show only up to 6 maximum emissions noted, or would be lesser, with " N/A " remark, if no specific emissions from the EUT are recorded (ie: margin>20dB from the applicable limit) and considered that's already beyond the background noise floor.
6. Margin (dB) = Remark result (dBuV/m) – Average limit (dBuV/m).



Test Mode: TX / IEEE 802.11n HT40 MHz (CH Mid)

Tested by: Jack Chen

Ambient temperature: 24°C Relative humidity: 52% RH

Date: March 29, 2016

Frequency (MHz)	Reading (dBuV)	Correction Factor (dB/m)	Result (dBuV/m)	Limit (dBuV/m)	Margin (dB)	Antenna Pole (V/H)	Remark
1801.000	51.72	-6.26	45.46	74.00	-28.54	V	Peak
2197.000	54.36	-3.92	50.44	74.00	-23.56	V	Peak
4879.000	45.08	4.59	49.67	74.00	-24.33	V	Peak
5806.000	40.21	6.00	46.21	74.00	-27.79	V	Peak
6895.000	40.04	7.53	47.57	74.00	-26.43	V	Peak
7759.000	40.49	9.18	49.67	74.00	-24.33	V	Peak
1198.000	55.29	-7.80	47.49	74.00	-26.51	H	Peak
1801.000	51.02	-6.26	44.76	74.00	-29.24	H	Peak
2197.000	50.41	-3.92	46.49	74.00	-27.51	H	Peak
2566.000	45.38	-2.14	43.24	74.00	-30.76	H	Peak
4879.000	45.41	4.59	50.00	74.00	-24.00	H	Peak
6904.000	40.20	7.54	47.74	74.00	-26.26	H	Peak

REMARKS:

1. *Measuring frequencies from 1 GHz to the 10th harmonic of highest fundamental frequency.*
2. *Radiated emissions measured in frequency above 1000MHz were made with an instrument using peak/average detector mode.*
3. *Average test would be performed if the peak result were greater than the average limit or as required by the applicant.*
4. *Data of measurement within this frequency range shown " --- " in the table above means the reading of emissions are attenuated more than 20dB below the permissible limits or the field strength is too small to be measured.*
5. *Measurements above show only up to 6 maximum emissions noted, or would be lesser, with " N/A " remark, if no specific emissions from the EUT are recorded (ie: margin>20dB from the applicable limit) and considered that's already beyond the background noise floor.*
6. *Margin (dB) = Remark result (dBuV/m) – Average limit (dBuV/m).*



Test Mode: TX/ IEEE 802.11n HT40 MHz (CH High)

Tested by: Jack Chen

Ambient temperature: 24°C Relative humidity: 52% RH

Date: March 29, 2016

Frequency (MHz)	Reading (dBUV)	Correction Factor (dB/m)	Result (dBUV/m)	Limit (dBUV/m)	Margin (dB)	Antenna Pole (V/H)	Remark
2053.000	51.06	-4.71	46.35	74.00	-27.65	V	Peak
2197.000	54.27	-3.92	50.35	74.00	-23.65	V	Peak
3286.000	44.80	-0.88	43.92	74.00	-30.08	V	Peak
4924.000	43.58	4.73	48.31	74.00	-25.69	V	Peak
6967.000	41.11	7.65	48.76	74.00	-25.24	V	Peak
7768.000	39.93	9.20	49.13	74.00	-24.87	V	Peak
1198.000	55.56	-7.80	47.76	74.00	-26.24	H	Peak
2197.000	50.57	-3.92	46.65	74.00	-27.35	H	Peak
4159.000	40.84	2.15	42.99	74.00	-31.01	H	Peak
4915.000	42.75	4.70	47.45	74.00	-26.55	H	Peak
6373.000	40.01	6.68	46.69	74.00	-27.31	H	Peak
7255.000	39.54	8.20	47.74	74.00	-26.26	H	Peak

REMARKS:

1. Measuring frequencies from 1 GHz to the 10th harmonic of highest fundamental frequency.
2. Radiated emissions measured in frequency above 1000MHz were made with an instrument using peak/average detector mode.
3. Average test would be performed if the peak result were greater than the average limit or as required by the applicant.
4. Data of measurement within this frequency range shown “ --- ” in the table above means the reading of emissions are attenuated more than 20dB below the permissible limits or the field strength is too small to be measured.
5. Measurements above show only up to 6 maximum emissions noted, or would be lesser, with “ N/A ” remark, if no specific emissions from the EUT are recorded (ie: margin>20dB from the applicable limit) and considered that's already beyond the background noise floor.
6. Margin (dB) = Remark result (dBUV/m) – Average limit (dBUV/m).



7.3. 6dB BANDWIDTH MEASUREMENT

7.3.1. LIMITS

According to §15.247(a)(2), systems using digital modulation techniques may operate in the 902 - 928 MHz, 2400 - 2483.5 MHz. The minimum 6 dB bandwidth shall be at least 500 kHz.

7.3.2. TEST INSTRUMENTS

Name of Equipment	Manufacturer	Model	Serial Number	Last Calibration	Calibration Due
Spectrum Analyzer	Agilent	E4446A	US44300399	02/21/2016	02/20/2017

7.3.3. TEST PROCEDURES (please refer to measurement standard)

8.1 Option 1:

- a) Set RBW = 100 kHz.
- b) Set the video bandwidth (VBW) $\geq 3 \times$ RBW.
- c) Detector = Peak.
- d) Trace mode = max hold.
- e) Sweep = auto couple.
- f) Allow the trace to stabilize.
- g) Measure the maximum width of the emission that is constrained by the frequencies associated with the two outermost amplitude points (upper and lower frequencies) that are attenuated by 6 dB relative to the maximum level measured in the fundamental emission.

7.3.4. TEST SETUP

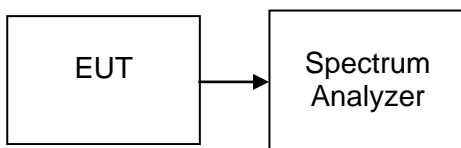



7.3.5. TEST RESULTS

No non-compliance noted

Test Data

Test mode: IEEE 802.11b

Channel	Frequency (MHz)	Bandwidth (kHz)	Limit (kHz)	Test Result
Low	2412	7098	>500	PASS
Mid	2437	7115		PASS
High	2462	7545		PASS

Test mode: IEEE 802.11g

Channel	Frequency (MHz)	Bandwidth (kHz)	Limit (kHz)	Test Result
Low	2412	16395	>500	PASS
Mid	2437	16413		PASS
High	2462	16407		PASS

Test mode: IEEE 802.11n HT20 MHz

Channel	Frequency (MHz)	Bandwidth (kHz)	Limit (kHz)	Test Result
Low	2412	17594	>500	PASS
Mid	2437	17613		PASS
High	2462	17604		PASS

Test mode: IEEE 802.11n HT40 MHz

Channel	Frequency (MHz)	Bandwidth (kHz)	Limit (kHz)	Test Result
Low	2422	35211	>500	PASS
Mid	2437	35171		PASS
High	2452	35164		PASS



Test Plot

