

# 4 Get Control

Your SVS PB-2000 PRO Subwoofer can be controlled from the new SVS Mobile App or via the rear panel for maximum flexibility when optimizing performance based on your room layout, speakers, system set-up and more.

## Download The App

The SVS App is the easiest and most convenient way to access all of the advanced control features available on your PB-2000 PRO, from the comfort of your favorite seat.



## On The Subwoofer

The rear panel features an intuitive all-new user interface with controls for adjusting the subwoofer's primary settings. The blue LED bar shows settings for Volume, Low Pass Frequency, and Phase. Simply press the setting you want to change and then use the "+" and "-" buttons to adjust the settings.

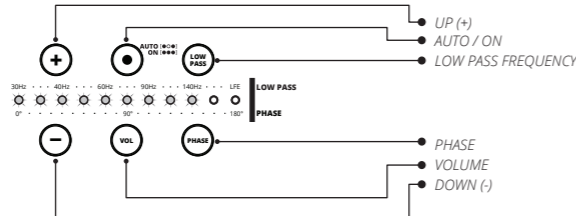

Please note, some DSP settings can only be accessed using the SVS app.

# 5 Get Calibrated

For connection to an AV Receiver, set the PB-2000 PRO volume to -10 in the app (on the rear panel, all but the last two lights illuminated). Set the low pass filter to LFE and the phase to 0 degrees, then run auto-set-up on the AV Receiver. Always re-run set-up if you move the subwoofer to another location.

For connection to a Stereo Receiver or Preamp without auto-set-up, adjust the PB-2000 PRO volume to match the output of your main speakers, and adjust the low pass filter to blend the bass between the PB-2000 PRO and your speakers. If needed, consult with our Sound Experts on the best phase setting.

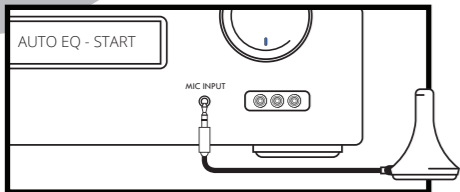

For additional guidance on recommended crossover or low pass filter settings specific to your system, visit our Subwoofer Matching Tool at [www.svsound.com/merlin](http://www.svsound.com/merlin), or just call, email or chat online with our Sound Experts: (877) 626-5623 | [custservice@svsound.com](mailto:custservice@svsound.com) | [www.svsound.com](http://www.svsound.com)



# Quick Start Guide PB-2000 PRO

Congratulations on choosing the SVS PB-2000 PRO, one of the most powerful and advanced subwoofers in the world. We know you're anxious to get it cranking so the following steps will guide you through the quick and easy installation process.

**We strongly recommend reading the PB-2000 PRO Owner's Manual to get the best possible performance out of your new subwoofer.** You'll find useful information about subwoofer placement, connections, DSP functions and more. The full SVS PB-2000 PRO Owner's Manual can be found here: [www.svsound.com/pb-2000pro-manual](http://www.svsound.com/pb-2000pro-manual)

## Unbox It

If you followed the PB-2000 PRO Subwoofer unboxing instructions properly you will have the following items in front of you. Please confirm all pieces are available before continuing.

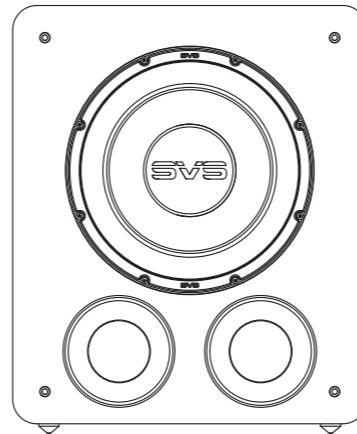

[PB-2000 PRO Subwoofer]

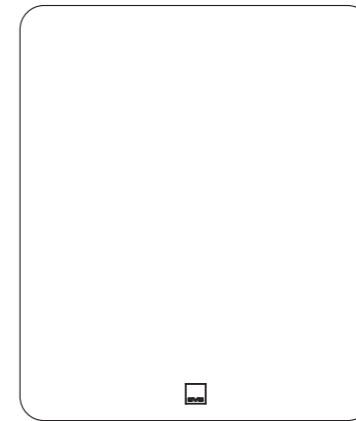

[Removable Grille]

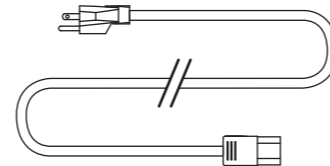

[Detachable Power Cord]

Register Your  
New SVS Product:



Thank you for choosing SVS! Registering your SVS product expedites any Sound Experts support requests, confirms your warranty registration and provides a proof of purchase. Plus, as a registered customer, you'll be the first to get SVS news and updates.

Register your product now at: [www.svsound.com/register](http://www.svsound.com/register)

# REGISTER

# REVIEW

**Review Your New SVS Product:**  
 Your SVS product is built with the highest standards of engineering excellence to achieve stunning sound quality and dynamics. Honest feedback is important to us and others making decisions about audio products. Please share your ownership experience with the SVS community by writing a review today.



Review your product now at: [www.svsound.com/review](http://www.svsound.com/review)

## 2 Set It Up

The location of your subwoofer in the listening environment can affect its performance. If possible, start with corner placement on the same wall as the front speakers, or anywhere along the front stage in between or outside of your main speakers.

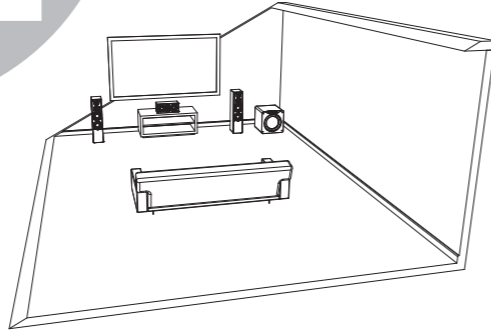

**Corner Placement:** offers huge impact and reduces the potential to encounter bass nulls, or 'dead spots'. If "boominess" occurs, you can try pulling it away from the wall and using the DSP tuning controls to smooth performance.

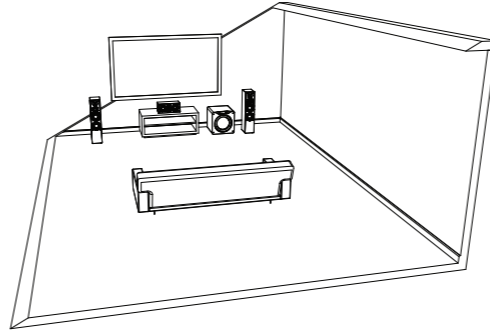

**Front Placement:** In between or to the side of the front channel speakers often results in the best blending with the main speakers and center channel and minimizes localization effects.

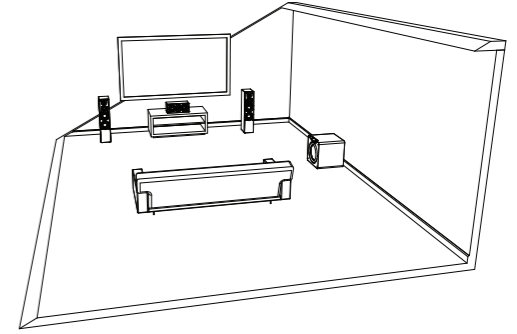

**Side Wall Placement:** Side wall placement is less frequently used but can be an effective subwoofer location for excellent accuracy and output.

## 3 Hook It Up

For most set-ups, a single RCA subwoofer interconnect cable running from the AV Receiver's "SUB 1" output to the PB-2000 PRO's "LFE" line level input is all that's required to connect the subwoofer into your system. If you run separate Preamp and Power Amplifiers, follow the "Line Level Connection - Stereo Receiver or Preamp Left/Right Channels" connection guide below.

### Line Level Connection - Single LFE Channel

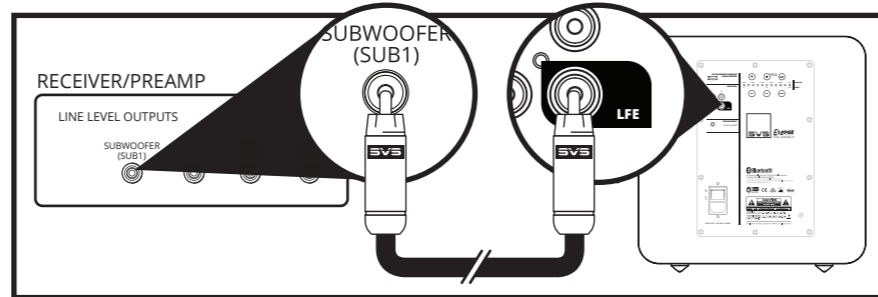

### Line Level Connection - Stereo Receiver or Preamp Left/Right Channels

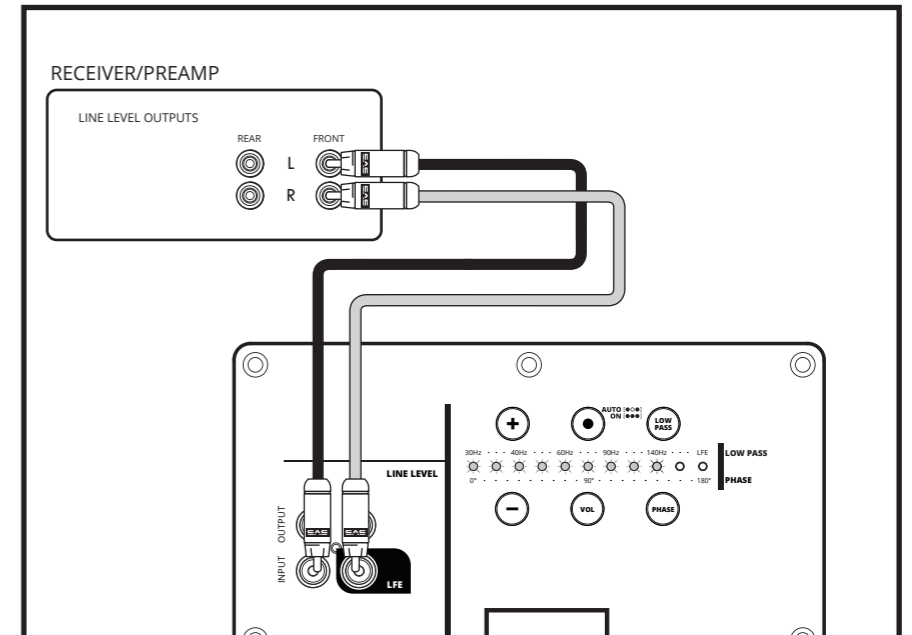

## Need Help?

Our Sound Experts are standing by to help with subwoofer placement, installation, calibration, AV receiver settings, room rattle and anything else you need advice about. Just call, email or chat online with our Sound Experts:

(877) 626-5623 | [custservice@svsound.com](mailto:custservice@svsound.com) | [www.svsound.com](http://www.svsound.com)

- Read these instructions.
- Keep these instructions.
- Heed all warnings.
- Follow all instructions.
- Do not use this apparatus near water.
- Clean only with dry cloth.
- Do not block any ventilation openings. Install in accordance with the manufacturer's instructions.
- Do not install near any heat sources such as radiators, heat registers, stoves, or other apparatus (including amplifiers) that produce heat.
- Do not defeat the safety purpose of any polarized or grounding-type plug. A polarized plug has two blades with one wider than the other. A grounding type plug has two prongs and a third grounding point. The wide blade or the third prong are provided for your safety. If the provided plug does not fit into your outlet, consult an electrician for replacement of the obsolete outlet.
- Protect the power cord from being walked on or pinched particularly at plugs, convenience receptacles, and the point where they exit from the apparatus.
- Only use attachments/accessories specified by the manufacturer.
- Use only with the cart, stand, tripod, bracket, or table specified by the manufacturer, or sold with the apparatus. When a cart is used, use caution when moving the cart/apparatus combination to avoid injury from tip-over.
- Unplug this apparatus during lightning storms or when unused for long periods of time.
- Refer all servicing to qualified service personnel. Servicing is required when the apparatus has been damaged in any way, such as power-supply cord or plug is damaged, liquid has been spilled or objects have fallen into the apparatus, the apparatus has been exposed to rain or moisture, does not operate normally, or has been dropped.
- **WARNING:** To reduce the risk of fire or electric shock, this apparatus should not be exposed to rain or moisture and objects filled with liquids, such as vases, should not be placed on this apparatus.
- This apparatus conforms to the use requirement in tropical and moderate climates, with a maximum temperature of the environment not exceeding 45°C (113°F).
- If the subwoofer is to be used in a confined space (e.g. built into furniture), the space must be ventilated to allow sufficient air to circulate and cool the unit.
- To completely disconnect this equipment from the mains, disconnect the power supply cord plug from the receptacle.
- The mains plug of the power supply cord shall remain readily operable.



The lightning flash with arrowhead symbol within an equilateral triangle is intended to alert the user to the presence of uninsulated "dangerous voltage" within the products enclosure that may be of sufficient magnitude to constitute risk of electric shock to persons.



The exclamation point within a triangle is intended to alert the user to the presence of importance operating and maintenance (servicing) instructions in the literature accompanying the product.

## FCC Statement

This device complies with part 15 of the FCC Rules. Operation is subject to the following two conditions: (1) This device may not cause harmful interference, and (2) this device must accept any interference received, including interference that may cause undesired operation.

NOTE: This equipment has been tested and found to comply with the limits for a Class B digital device, pursuant to part 15 of the FCC Rules. These limits are designed to provide reasonable protection against harmful interference in a residential installation. This equipment generates, uses and can radiate radio frequency energy and, if not installed and used in accordance with the instructions, may cause harmful interference to radio communications. However, there is no guarantee that interference will not occur in a particular installation. If this equipment does cause harmful interference to radio or television reception, which can be determined by turning the equipment off and on, the user is encouraged to try to correct the interference by one or more of the following measures:

- Reorient or relocate the receiving antenna.
- Increase the separation between the equipment and receiver.
- Connect the equipment into an outlet on a circuit different from that to which the receiver is connected.
- Consult the dealer or an experienced radio/TV technician for help.

**WARNING:** Any changes or modifications to this unit not expressly approved by the party responsible for compliance could void the user's authority to operate the equipment.

The device must not be co-located or operating in conjunction with any other antenna or transmitter.

"FCC RF Radiation Exposure Statement Caution: To maintain compliance with the FCC's RF exposure guidelines, place the product at least 20cm from nearby persons."

## IC Statement

This device complies with RSS247 of Industry Canada. Cet appareil se conforme à RSS247 de Canada d'Industrie. This device complies with Industry Canada license-exempt RSS standard(s). Operation is subject to the following two conditions: (1) this device may not cause interference, and (2) this device must accept any interference, including interference that may cause undesired operation of the device. appareils radio exempts de licence. Son fonctionnement est sujet aux deux conditions suivantes: (1) le dispositif ne doit pas produire de brouillage préjudiciable, et (2) ce dispositif doit accepter tout brouillage reçu, y compris un brouillage susceptible de provoquer un fonctionnement indésirable

This device complies with FCC and IC radiation exposure limits set forth for an uncontrolled environment. Cet appareil est conforme aux limites d'exposition aux rayonnements de la FCC et de l'IC établies pour un incontrôlé environnement.

The device should be installed and operated with a minimum distance of 20cm between the radiator and your body. L'appareil doit être installé et utilisé avec une distance minimale de 20 cm entre le radiateur et votre corps.