

Confidential



Manual

TetraNode Base Station System

TetraNode





**Correct Disposal of This Product
(Waste Electrical & Electronic Equipment)**

(Applicable in the European Union and countries with separated waste collection systems).

This marking shown on the product or its literature indicates that it should not be disposed of with household waste at the end of its working life.

To promote the sustainable reuse of material resources and to prevent possible harm to the environment or human health from uncontrolled waste disposal, please separate this from other types of wastes and recycle it responsibly.

Users should contact either the retailer where they purchased this product, or their local government office, for details of where and how they can send this item for environmentally safe recycling.

Business users should contact their supplier and check the terms and conditions of the purchase contract. This product should not be mixed with other commercial wastes for disposal.



© Copyright 2009-2015, Rohill Technologies B.V.

Issue 1.0, 18 November 2015 This version supersedes all previous versions. Please check you have the latest version before continuing.

Information in this manual is subject to change without notice and does not represent a commitment on the part of the manufacturer. This manual is copyrighted; it may not, in whole or in part, be copied, photocopied, translated, or reduced to any electronic medium or machine readable form without prior consent in writing from Rohill Technologies B.V.

Rohill Technologies B.V. / Rohill Engineering B.V.

Edisonstraat 12

7903 AN Hoozevee

The Netherlands

Telephone: +31 528 263355

Telefax: +31 528 271844

Internet: www.rohill.com

Change history

Version	Date	Name	Changes
V1.0	18-11-15	HW team	FCC version of manual. FCC warnings added.

Warnings and Cautions



Caution:

This manual contains important information concerning installation, maintenance and user instructions for the R-8070 based TetraNode Base Station.

Read the following pages before installing or using the equipment.



Warning:

This Equipment **MUST** be connected to a SAFETY EARTH.



Warning:

Do **NOT** operate the TetraNode Base Station without a suitable high-power 50Ω load(s) or correctly tuned antenna system being connected.



Warning:

Do **NOT** touch or disconnect live (in use) antennas – RF energy can cause burns!



Warning:

Always ensure that the equipment is turned off before disconnecting antenna cables.



Warning:

If working on a partially running site (half online), be careful of live power and RF connections.



Warning:

If connecting to floating power supplies take care to minimise touch-currents. Correctly earthed supplies are preferred over floating supplies.

**Warning:**

If dual power supplies are used for redundancy, ensure warnings are clearly posted on the cabinet and double circuit isolators are provided.

**Warning:**

Do not connect equipment-room earth to the same earth used for the tower lightning protection.

**Warning:**

Do NOT work on antenna cables or systems when there is any nearby/local electrical storm activity.

**Warning:**

The protective earths within the TetraNode Base Station should be adequately bonded to the electrical earth of the 19" rack cabinet and NOT to any lightning protection system for transmitter-towers/antennas.

**Warning:**

The power supply for the TETRA Base Station is low-voltage, but is nonetheless capable of delivering a hazardous energy level if short-circuited. Always disconnect the power before working on this equipment or connected systems.

**Warning:**

All power installations must additionally comply with all local wiring regulations.

**Warning:**

Do NOT fit 3rd party equipment into this cabinet. Operating the equipment with non-Rohill-approved components inside invalidates all warranties and may compromise your safety!

**Warning:**

This device complies with part 15 of the FCC rules. Operation is subject to the following two conditions: (1) This device may not cause harmful interference, and (2) this device must accept any interference received, including interference that may cause undesired operation.

**Warning:**

Rohill Engineering B.V. is not responsible for any changes or modification not expressly approved by the party responsible for compliance. Such modifications could void the user's authority to operate the equipment.

**Caution:**

Service and /or maintenance of this equipment should only be carried out by qualified and trained service technicians/personnel. Ensure cabinet and/or equipment room is kept locked.

**Caution:**

This equipment is designed to transmit and receive RF signals for which a **license is normally required**. Although the equipment complies with the manufacturing requirements for such equipment, it is the responsibility of the customer to obtain a suitable license and to ensure that local requirements and compatibility issues are complied with.

**Caution:**

When testing a running base site, consider first the impact on users before disconnecting equipment!

**Caution:**

The calibration of the crystal reference in the TBS-SYN can be detuned by mechanical shock. References so affected must be reconnected to a GPS signal until auto-calibration has settled and corrected any errors.

**Caution:**

The transmitter output and receiver input filters are qualified by Rohill for their high performance and form part of the output filtering circuit. They must not be replaced with alternatives nor be manually re-tuned.

**Caution:**

12VDC is present on the receiver inputs of the R-8070. Do NOT short circuit the receiver inputs. Do NOT connect receivers to test equipment without a DC block.

**Caution:**

All unconnected connectors should remain unconnected unless otherwise stated by Rohill. Unconnected connectors inside a BSS do not require any termination either by design or by function.

This statement is not applicable for connectors meant for external connections such as the ANT (antenna) output of combiners, power supply.

Table of Contents

1	Introduction	10
1.1	Scope	10
1.2	Base Station System overview	10
2	System Options	11
2.1	Number of carriers	11
2.2	Cabinet	11
2.3	Power supply	11
2.4	Frequency bands	12
2.5	Transmitter output power	12
2.6	TBS-SYN Timing reference	13
2.7	Line Interface(s)	14
2.8	Environmental	15
3	Technical description	16
3.1	R-8070 transceiver	16
3.1.1	Transceiver User Interface (MMI)	16
3.1.2	Transceiver Alarms and Warnings	21
3.2	Synchronisation TBS-SYN	21
3.3	Connections	22
3.3.1	R-8070 connections	22
3.3.2	R-855 TBS-SYN rear panel layout	24
4	Installation and configuration	25
4.1	Equipment room requirements	25
4.1.1	Equipment-room earth	26
4.2	Installation – floor standing cabinets	26
4.2.1	Ventilation and cooling	27
4.3	Power-supply and Earthing	27
4.3.1	Earthing	28
4.3.2	AC Power cables	28
4.3.3	DC Power cables	29
4.3.4	Power supply	29
4.4	Network Connections	29
4.5	Antenna system	30
4.5.1	Lightning protection	30
4.5.2	Minimization of exposure to non-ionizing radiation	30
4.6	BSS Configuration	31
5	Maintenance and replacement	32

5.1 General	32
5.2 Maintenance policy	32
5.3 Maintenance	32
6 Troubleshooting	33
6.1 General	33
6.2 R-8070 Alarm messages	33
7 Specifications	34
7.1 General transceiver specifications	34
7.2 Receiver specifications	34
7.3 Transmitter specifications	35

1 Introduction

1.1 Scope

This manual covers the R-8070 based TetraNode Base Station System. Available options, a technical description and guidelines for its installation, operation and maintenance are provided.

This manual covers all available frequency band variants and standard configurations. Special configurations and external components such as power back up systems and back-haul networks are not covered by this manual.

Guidance notes (for information) are written in *italics*.

Where specifications are given, these are for illustration as they may be subject to change. The definitive figures should be checked on the appropriate product data sheet.

The R-8070 transceiver **MUST** be operated in combination with the supplied antenna combiner system. i.e. The antenna filters, combiners and low noise amplifier are now part of the transceiver.

1.2 Base Station System overview

A TetraNode Base Station System is designed to provide the radio frequency carriers for one TETRA base site. As standard it consists of one cabinet containing one to four R-8070 transceivers and all the associated cabling, antenna combining, synchronisation unit(s), optional fall-back site controller, line interfacing and optional power supplies.

All Rohill Base Stations are supplied fully assembled and tested. It remains only for antenna connections, power and system (network) connections to be made.

2 System Options

2.1 Number of carriers

The standard number of carriers per cabinet is two or four. However cabinets can be sub-equipped for one or three carrier configurations. If more than four carriers per site are required, then multiple cabinets should be co-located.

2.2 Cabinet

The standard R-8070 Base Station System (1 to 4 carriers) is supplied in a 1670mm high (32U internal) 19" rack unit. 600x600mm footprint with lockable front and rear doors. Colour light grey (RAL 7047). Front door is solid. Rear door is ventilated (exhaust air) top and lower/middle. Main air inlet is under rack, main air exhaust is lower/middle of rear door.

2.3 Power supply

The standard R-8070 Base Station System is supplied from a single +24V (nominal) DC connection. DC range is 18-36VDC negative earth. 3 and 4 carrier systems are dual-redundant supply as standard. Switching power control and backup (e.g. UPS) must be provided separately and externally. Supply options are available for:

- 18-36VDC (nominal +24VDC) negative earth
- AC mains. Input range 100-240VAC 50/60Hz

The system is also prepared for 36-58VDC (nominal -48VDC) positive earth – please enquire. Configurations can be:

- non-redundant, or
- dual-redundant

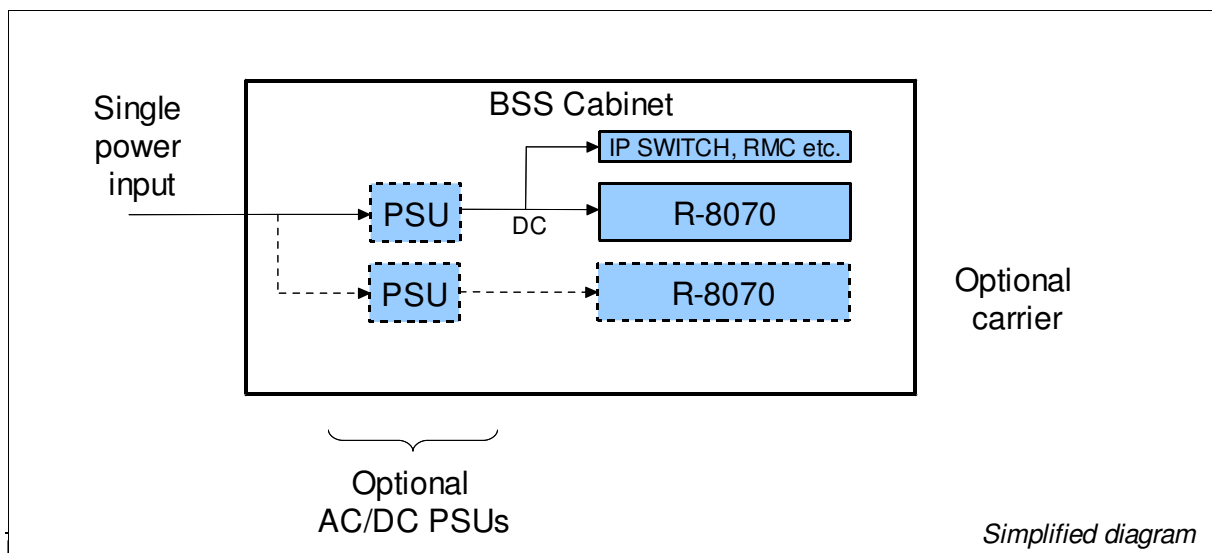

The R-8070 transceivers are each supplied from their own AC/DC PSU. For true redundant operation two power supply input connections are required. Normally, each input will power half of the equipment in the rack.

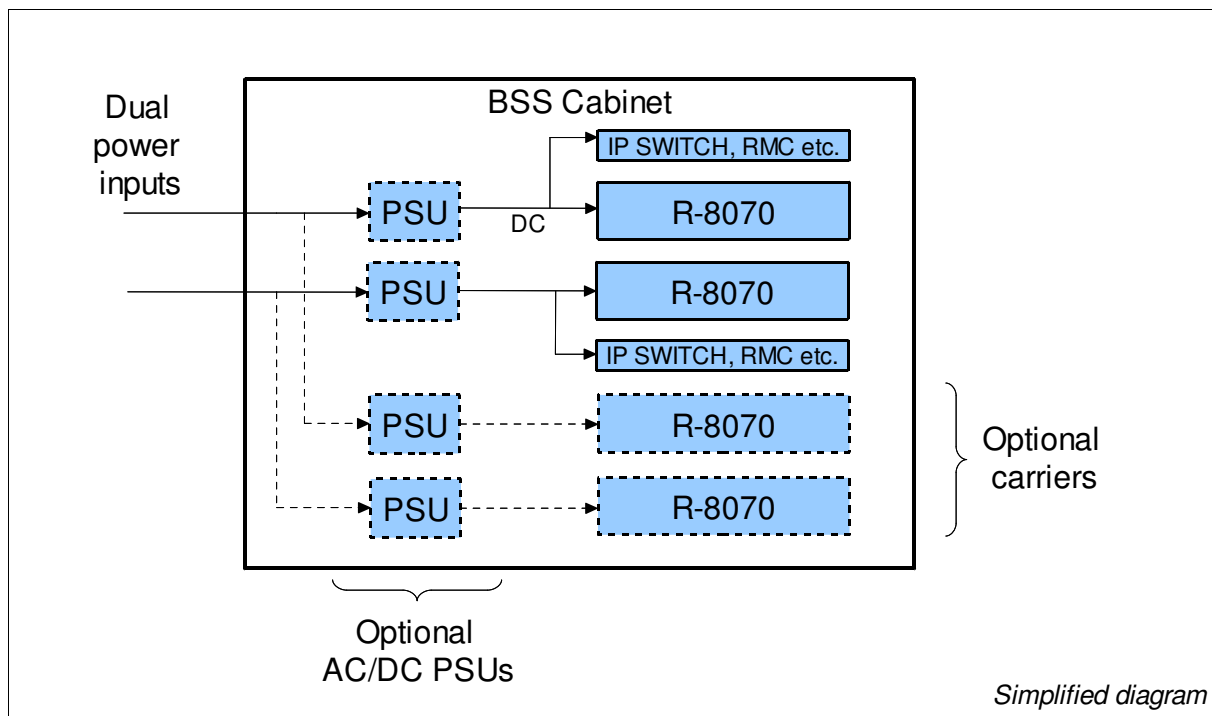

Figure 2, Dual redundant power supply, 2-4 carriers

2.4 Frequency bands

The transceiver unit(s) used in the system have a fundamental tuning bandwidth of 20MHz. The transmitter and receiver can be independently tuned anywhere in this range subject to permitted configurations [see ETSI TS 100 392-15].

Below 500MHz, this range is further constrained by the antenna filtering solution to a pair of 5MHz sub-bands (normally 10MHz duplex offset). Above 500MHz, with 45MHz duplex split, the full band is covered by one antenna system variant.

Standard duplex split is 10MHz when below 500MHz otherwise 45MHz. Other duplex offsets are possible, but may be specials – please enquire. Reverse operation is possible on all bands below 500MHz.

2.5 Transmitter output power

All powers are quoted as continuous rated RMS values. The maximum output power of the R-8070 transceiver (before antenna combining) is +46dBm rms (approx 40W). Lower powers (1dB steps down to 33dBm (2W)) are configured in software.

Note: the approximate loss of a 2:1 hybrid + duplexer/Tx-filter is 4dB.

2.6 TBS-SYN Timing reference

The R-8070 site always contains at least one timing reference. This can be either with or without GPS receiver. Note - Seamless handover is only supported when the system is locked to GPS. A second reference is fitted for dual-redundant operation. The timing reference is normally powered from the R-8070 transceiver(s). Dual power inputs are available for sites with partial redundancy. Specify if required. Timing references without GPS are factory calibrated against GPS. They are designed to run for 10 years within specification.

**Caution:**

The calibration of the crystal reference in the TBS-SYN can be detuned by mechanical shock. References so affected must be reconnected to a GPS signal until auto-calibration has settled and corrected any errors.

2.7 Line Interface(s)

The standard for connecting TetraNode Base Station Systems to the back-haul network (modems) is Ethernet 10/100baseT.

1 – 2 carrier systems contain one switch.

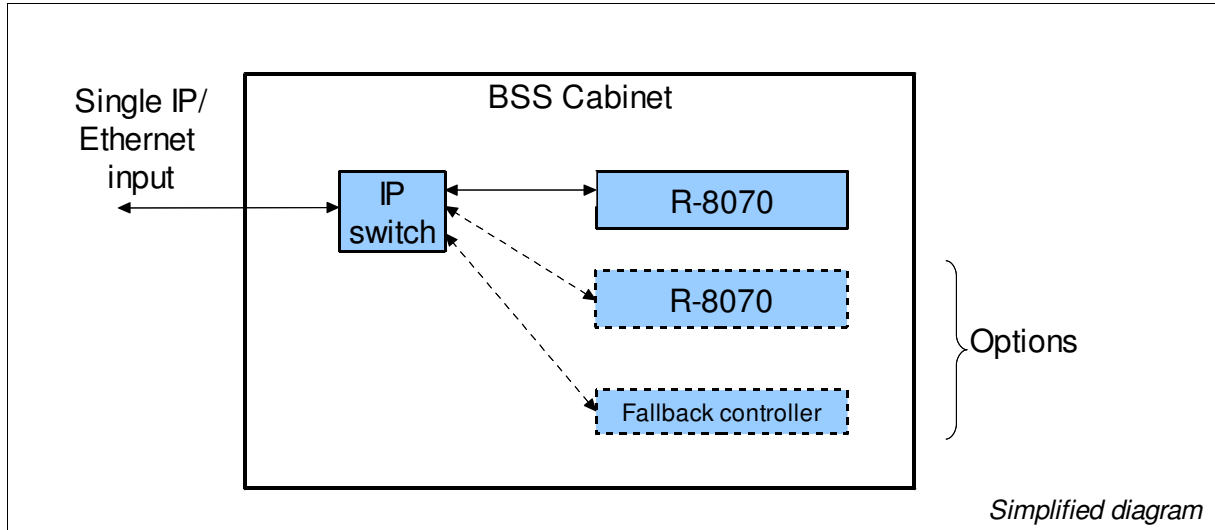

Figure 3, 1-2 carriers, FSC option, single switch

3 – 4 carriers systems are offered with a second switch for dual redundancy. A second set of IP addresses are used in the redundant case.

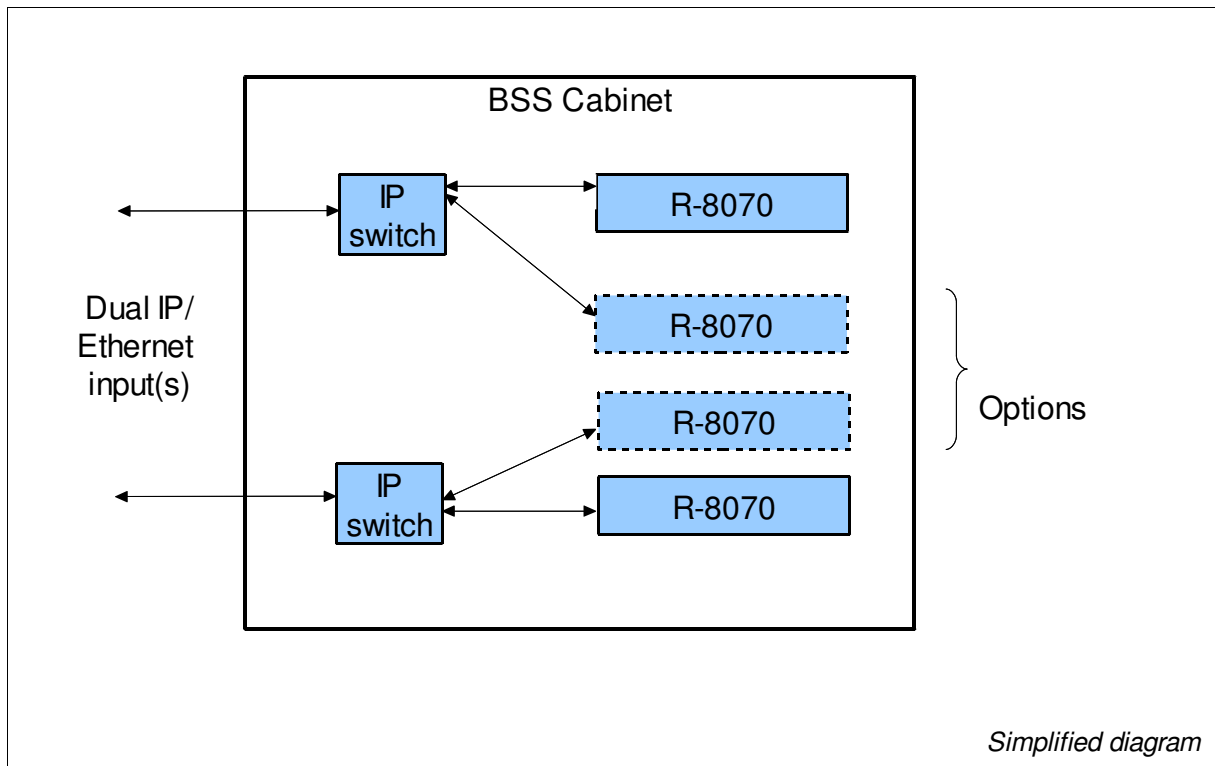

Figure 4, 2-4 carriers, Dual line option, dual switches

2.8 Environmental

The BSS is designed for operation in a dry weather protected and vibration-free location. Exposure to solar radiation should be limited. High humidity can be tolerated, but **MUST** be non-condensing conditions. Air conditioning is only required if the performance envelope of the equipment inside the rack would otherwise be exceeded. However, improved life time and performance will be achieved if temperature is kept below extremes. Temperature performance of the carriers is defined at the air-intake of the transceiver sub-rack.

3 Technical description

3.1 R-8070 transceiver

3.1.1 Transceiver User Interface (MMI)

The User Interface or Man-Machine Interface (MMI) is provided by a 4.3 inch full-colour LED-backlit touch-screen LCD display mounted in the front panel see Figure 5.

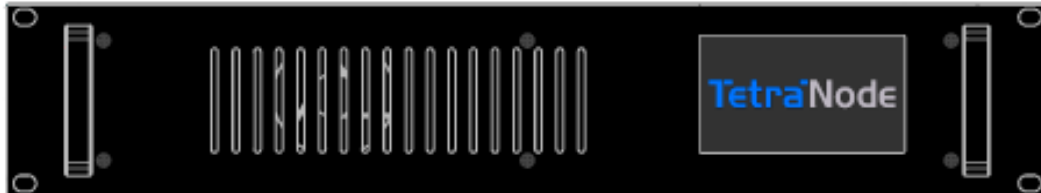

Figure 5, R-8070 transceiver front view

Status, error-codes, heart-beat, configuration and diagnostic/test information can be shown.

After a time-out the display will revert to a screen-saver mode. This can be disabled.

3.1.1.1 MMI operation

At power-up the touch-screen MMI will initially show a TetraNode splash screen whilst the carrier is booting up.

The display will then directly enter the *System Settings* sub-screen:

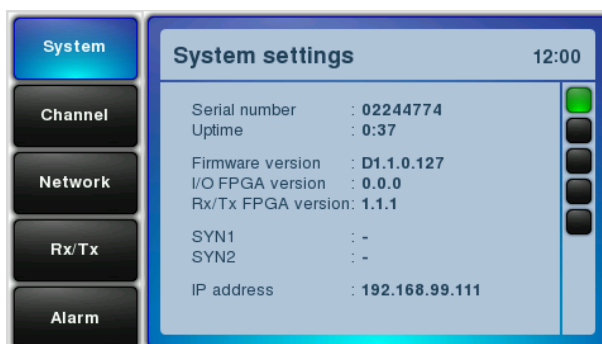
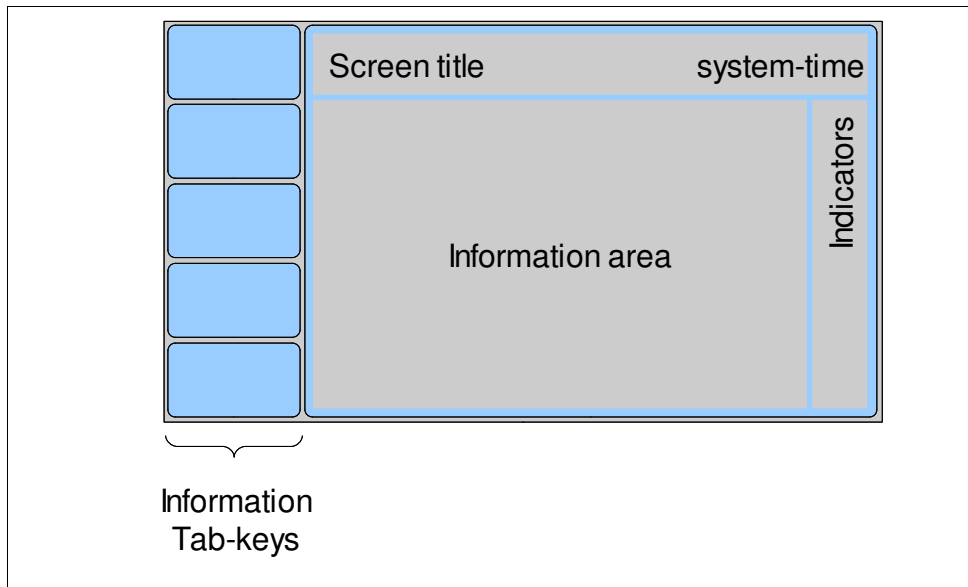

Figure 6, R-8070 MMI generic screen layout

The generic layout of each sub-screen is:



Touching the screen anywhere in the information area will return the user to the *top level* screen:

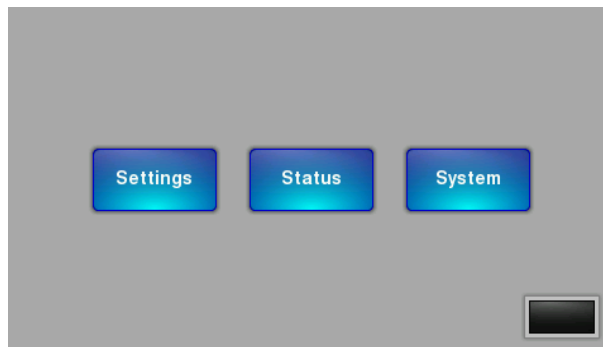
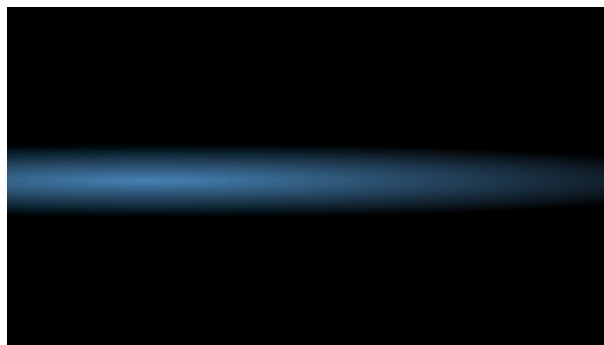

Figure 7, R-8070 MMI Top-level screen

This screen has three navigation buttons and one button (bottom right) to toggle screen-save on/off. When enabled, the display (default) will enter a screen save mode after a time-out period of 60 seconds (10 seconds if after clearing an alarm). The screen saver is a left-scrolling image:



touching the screen will exit screen-save and return to the last viewed screen.

The navigation keys correspond to the three sub-screens described below.

3.1.1.2 Menu Map

The top level menu (Figure 7) presents three choices. The categories within each of these then operate as a “tab” selection, i.e. the selected sub-sub-category is highlighted with a blue tab-key.

Top Level -----

select one of the following three categories:

SETTINGS ---

System

serial number
uptime (days hours:minutes)
Firmware version
I/O FPGA version
Rx/Tx FPGA version
Primary SYN1 serial number
Secondary SYN2 serial number
IP address



Channel

Frequency band (3|4|8)
Channel number
*Frequency offset (-6.25kHz|0kHz|
+6.25kHz|+12.5kHz)*
Duplex spacing
Reverse operation (yes|no)
Transmit frequency (MHz)
Receive frequency (MHz)

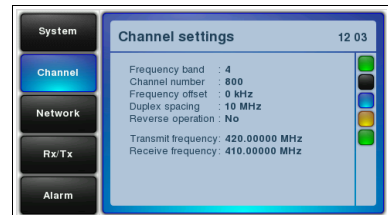

Network

Mobile country code
Mobile network code
Base-station colour code
TNX (name, description)

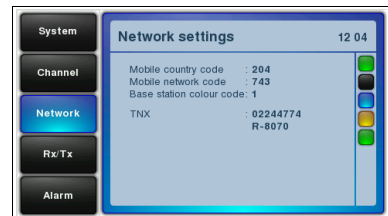

Rx/Tx

Receive diversity (on|off,on|off,on|off)
Transmitter standby timeout
*PA temperature limits (warning/abs-
max)*
Power level

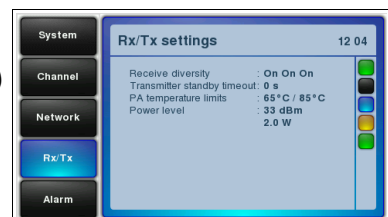

Alarm

list of alarms & warnings
-see section 6.2



STATUS ---

Controller

uptime (days hours:minutes)
Connection (TNSP | IP-Link)
TNX (name, description)
card temperature (C)



Receiver

RSSI value (dBm) by time-slot and receiver
uplink assignment summary (1 row)
scrolling histogram of received data
black – unallocated
blue – control-channel
yellow – traffic
card temperature (C)

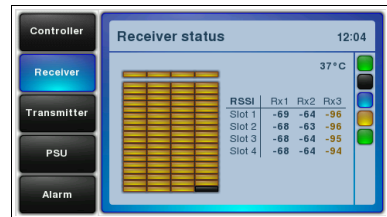

Transmitter

Output (W)
scrolling histogram of transmitted slot types
PA temperature (C)
Tx card temperature (C)

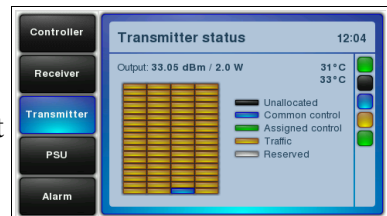

PSU

input voltage (V)
card temperature(C)

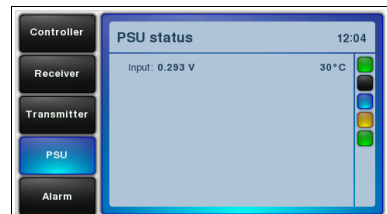

Alarm

list of alarms & warnings
-see section 6.2

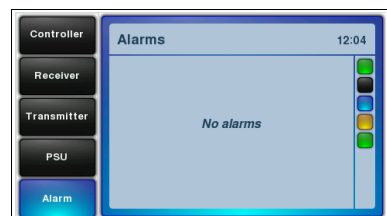

SYSTEM ---

IP address (when empty DHCP used)

[keypad], <backspace> and <enter>
keys for setting:

IP address

network mask

Default gateway

Reset

press both buttons (sequentially),
within 1 second, to reset the carrier.

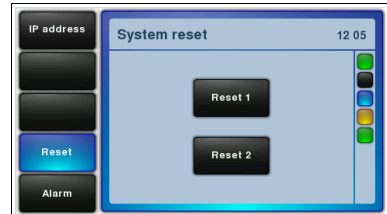
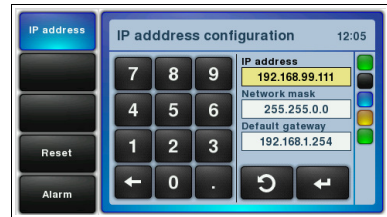

Caution:

Please note that if this soft-button is used during normal operation it will cause an interruption of service to the users.

Alarm

list of alarms & warnings

-see section 6.2

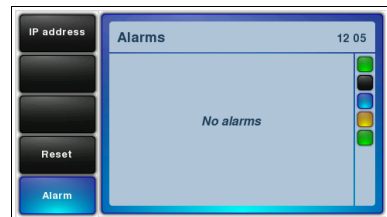

3.1.1.3 MMI status indicators

There are five indicators on the right hand side of the display. These have the following meanings:

- (green) *Reserved for future use*
- (black/red) ALARM indicator
- (black/blue) Tx ON indicator
- (black/yellow) Rx ACTIVE
- (black/green) CONNECTED to TNX or ber-test, (white) LOCAL

3.1.2 Transceiver Alarms and Warnings

If an alarm state occurs, the Alarm tab-key is highlighted red. An alarm is something that is critical to continued operation, e.g. will/has caused failure.

If a warning state occurs, the alarm tab-key is highlighted yellow. A warning is something that affects performance but is non-critical e.g. temperature unusually high. In normal operation, the alarm tab-key is black or blue(selected). For a full list of alarms & warnings see section 6.2 If the transceiver is in screen-saver mode, the display will “wake-up” when an alarm or warning occurs.

3.2 Synchronisation TBS-SYN

The TBS-SYN provides a high stability reference clock from a precision oven-controlled oscillator. Once calibrated, this oscillator will stay within specification for ten years or more. However free-running systems (no GPS antenna) should be periodically checked for accuracy in case of mechanical shock or other detuning.

Fitting the GPS receiver antenna is strongly recommended. GPS satellite timing signals provide a master reference to phase lock and auto-calibrate the ovened crystal reference. GPS reception is essential for systems supporting seamless handover.

One unit can synchronise up to 16 transceivers. Two units are fitted in dual-redundant system designs. Connections to transceivers are made with star connected RJ-45 cables. Power and timing-reference cables are <3m to comply with EMC requirements.

The TBS-SYN is designed to be powered from one or two R-8070 base station transceivers. The second power cable is only fitted as a special as it is only required by partially redundant systems. E.g. in the case that one TBS must be removed without disabling the other(s).

A TBS-SYN contains one GPS receiver with a 3.3V DC power output on the receiver MCX connector for powering a remote active antenna. The antenna and lightning protection must guarantee a DC feed with no short circuit to the active antenna.

Management and GPS signal quality information is available to the network via the transceiver control.

3.3 Connections

3.3.1 R-8070 connections

3.3.1.1 IP connections

In normal systems standard Ethernet network components can be used. However some basic checks should be made:

First make sure that the Ethernet backbone is a dedicated service with a high degree of reliability, say at least an availability of >99.99%. Virtual private networks over the Internet may be cost effective, but are unreliable, especially considering the packet delay and jitter.

Secondly, it is desirable to use a Quality of Service mechanism using DiffServ, also called Differentiated Services Codepoint (DSCP). This allows the operator to carry different classes of traffic over the IP network, the service for connecting TetraNode base stations will use Expedited Forwarding mode. Make sure this is supported.

3.3.1.2 Transmit Antenna connector

The female-N-type Tx power connector at the rear of the transceiver has a 50 Ω unbalanced characteristic impedance. It is connected to the antenna system with a good quality flexible double screened coaxial cable.

The transmitter antenna system should always provide at least 80dB transmit to receive isolation. Therefore always ensure good connections and maximise Rx-Tx cable separations.

Isolators are built-into 20MHz bandwidth PAs as standard, thus the R-8070 is suitable for multi-Tx sites without supplementary intermodulation protection. Extra isolators are also present in the hybrid or cavity combiners.

There is a red-LED next to the output connector. Do NOT remove the antenna/load if this is lit.

**Caution:**

transmitter cables are often critical lengths and should not be cut or mixed up. This is especially true for cavity combiners.

3.3.1.3 Receiver Antenna connectors

The three female snap fit QMA receiver antenna(s) connectors at the rear have a nominal 50 Ω unbalanced characteristic impedance. All three inputs are

equivalent. To provide diversity gain, connect the receivers to physically separated antennas. Ideal diversity separation 7 to 10 lambda (wavelengths). For best performance, diversity antennas should be at the same height (so that they receive comparable average powers)

If multiple R-8070s are used on one site, then received signals are normally split with a Receiver Multi-Coupler. The amplifier in the Coupler must have noise figure and OIP3 performance similar to the R-8070 in order to preserve performance.

On sites with strong signals from other systems, ensure that the receiver amplifier is far from overload. A band limiting filter (pre-selector) should always be fitted (usually part of receiver multi-coupler or duplex filter).

Transmit-receive isolation should exceed 80dB. Use double-screened coax and maximize physical separations between Rx-Tx (e.g. dress cables on opposite side of the rack).

Unused receivers should be disabled (see configuration) to optimize system performance.

3.3.1.4 Synchronization inputs

The reference frequency and synchronization data from the TBS-SYN enters the R-8070 via the SYNC input connector. The spare input is for use in dual-redundant systems.

The R-8070 is designed for a (dual) star connection of synchronisation clocks.

3.3.1.5 RS-232 / DE-9 connector

An asynchronous RS-232 serial port is available on the DE-9 connector. This connector is intended only for testing and alignment of the R-8070 during manufacturing, and cannot be used during normal operation and maintenance.

3.3.1.6 Protective earth

One of the rear panel mounting screws should be connected to the rack protective ground with a short heavy-gauge cable (minimum cable 7/0.85 mm (4 mm²)). To minimise inductance, this cable should NOT be looped/ coiled as it is to provide operator and equipment protection from fast transients and surges. The equipment rack/housing in turn should use a heavier gauge cable/strap to connect to the communications room protective earth.

If in doubt, consult an expert on lightning protection.



Warning:

The protective earths within the TetraNode Base Station should be adequately bonded to the electrical earth of the 19” rack cabinet and NOT to any lightning protection system for transmitter-towers/antennas.

3.3.2 R-855 TBS-SYN rear panel layout

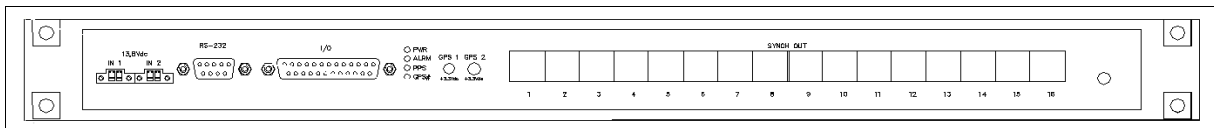

Figure 8: TBS-SYN rear panel connector layout

IN 1	IN 2	RS232	I/O	LEDs	GPS	Synchronisation outputs 1..16	
------	------	-------	-----	------	-----	-------------------------------	--

3.3.2.1 Connector Details

Label	Description
IN 1, IN 2	Twin DC power inputs 12-13.8V
RS-232	(DE-9) Connector for RS-232 diagnostics - factory only
I/O	Input/Output (DB-25) connections for 3 rd party ancillaries etc. (pin-out definition required)
LEDs	PWR Power on (green) ALRM Alarm present (red) PPS Pulse per second (green) GPS# GPS locked (yellow)
GPS	Female MCX connector with +3.3VDC on centre pin for GPS active antenna.
Sync out 1..16	RJ45 x 16 Synchronisation outputs
	Connect earth cable with ring termination under one of the rear panel screws

4 Installation and configuration

The initial alignment and calibration (and if required, factory acceptance testing) of the units is performed in the factory. This section describes the installation after delivery. The cabinets are shipped fully equipped and ready for use. The basic sequence for installation should be:

1. antenna earths and lightning protection
2. equipment room earths (separate from (1))
3. antennas and cables
4. equipment room power-supplies and lighting
5. cabinet placement
6. cabinet earths
7. antenna connections
8. network connections
9. cabinet power connections
10. configure, test and commission (include updating site documentation)



Warning:

Ensure that cables do NOT lie across any sharp metal edges. This applies to ALL cables of all types.

4.1 Equipment room requirements

Equipment must always be operated in a secure manner – i.e. with locked doors and/or in locked “authorised access only” areas. Thus, if possible, choose equipment room locations that are secure, but do not require extra special permissions/training for personnel requiring access (e.g. intrinsic safe areas in oil refineries or hygiene restrictions of drinking-water towers).

All standard TetraNode variants are designed for installation in a weather protected (dry) environments, i.e. an equipment room, except for some specials, such as the “ultra-lite” and transportable cabinets

In all cases, humidity may be high, but must be **non**-condensing. Condensation may be prevented by keeping equipment temperatures higher than circulating air temperature. Consider the likelihood of rapid rises in air temperature that may leave equipment (with high thermal mass) temporarily at a lower temperature.

In the equipment room, ensure that temperature remains within the maximum and minimum operating-limits of the equipment in use. This is usually defined with respect to the (ambient) air inlet of the component in question. It may be necessary to consider the effects of closed cabinet operation and (for specials) ancillary equipment that may be mounted in the rack.

Requirements for air conditioning (chillers) can usually be avoided due to the wide operating range for TetraNode equipment, thus saving considerably on running costs. NB Low temperature operation will generally lead to longer equipment life.

The equipment room should be dry and relatively dust free (clean) and vermin free. For all other environments, the equipment should be fitted in an appropriate environmental housing.

4.1.1 Equipment-room earth

The equipment room should have its own low-impedance protective earth system separate from that of the antenna tower. All incoming/outgoing cables should also be protected (earthed) at the entry point to the equipment room.

Equipment room earth should ideally be constructed as a “halo” over the equipment with connections to ground at the corners. This effectively creates a Faraday cage over and around the equipment.



Warning:

Do not connect equipment-room earth to the same earth used for the tower lightning protection.

When sited near railways also consider extra shielding from magnetic fields and anti-vibration mounts for equipment.

4.2 Installation – floor standing cabinets

Standard R-8070 Base Station configurations are supplied in a 37.5U 19” floor standing cabinet (600x600mm footprint) with supporting shelves or slide rails. The system components are held in the rack by M6 (pozidrive) screws.

The cabinet is designed for internal-cable access at the rear and normal operation/monitoring from the front.

External cables can enter either through the cabinet floor or the lid.

The rack is supported on four feet, but also has two wheels at the front for easy installation. When in position, wind the feet down to equalise the support and level the cabinet.

Ensure that the rear panel can be lifted off if required and the associated earth strap can be removed/replaced without damage.

Ensure that the cabinet will be adequately lit when being worked on. NB. Doors are hinged on the left.

Ensure the earth is connected first.

4.2.1 Ventilation and cooling

Cool air is required at the front/underside of the R-8070 cabinet. Hot air is exhausted at the rear/top. Ensure that hot air is NOT recirculated into the inlet.

Sufficient ventilation to remove typically 190 W per carrier (on full power) and worst case 250 W should be provided. Typically an area of 2 x (15 cm x 15 cm) per carrier should be sufficient for the inlets and outlets respectively.

Allow extra ventilation for cooling of hybrid combiner, power supplies, fall-back site controller, IP-switch and TEP-rack, as required.

Ensure that the installation location is clean to prevent build up of dust in the ventilation grills. Ventilation ducts should be screened with a thin mesh of ~1 cm to keep vermin/debris out and yet not get clogged with dust.

4.3 Power-supply and Earthing



Warning:

All power installations must additionally comply with all local wiring regulations.



Warning:

The cabinet(s) must be supplied via READILY ACCESSIBLE power switch(es).



Warning:

If dual power supplies are used for redundancy, ensure warnings are clearly posted on the cabinet and double circuit isolators are provided. Each isolator must be double-pole, with certified breaking capacity and voltage rating suitable for the cabinet version in question.

**Warning:**

The protective earth point within the TETRA Base Station cabinet should be adequately bonded to the electrical earth of the 19" rack cabinet and NOT to any lightning protection system for transmitter-towers/antennas.

**Warning:**

If connecting to floating power supplies take care to minimise touch-currents. Correctly earthed supplies are preferred over floating supplies.

4.3.1 Earthing

Firstly - All cabinets must first be permanently cross-bonded (connected) to the protective earth point(s) to protect operators from dangerous surges and possible touch currents from 3rd party equipment. Use only a single star connection point. Max cable length 2m. Use double crimped or soldered and strain-relieved ring terminals, do not use spade terminals.

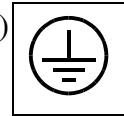

Earth connections must be low impedance (minimum cable cross section MUST exceed that of the (total) supply cable. In any case minimum 7/0.85 mm cable (4 mm²) per two carriers).

Once the protective earth connection is made, other work may proceed.

If multiple cabinets are installed, independently star-connect them to the safety earths.

If third party equipment (e.g. power supplies, line equipment) are used, check that the touch currents (leakage to ground) will not accidentally trip building RCDs (residual current breakers).

4.3.2 AC Power cables

All cables must be installed so as to avoid abrasion (wear) and other forms of damage. Do not run cables over any unprotected metal edges.

The AC power cable must use conductors with cross sectional area $\geq 1.25\text{mm}^2$ per cabinet. Use only (marked) certified cable types (tested for safety and compliance with ratings).

Supplied power cables can be directly connected into isolation switches. Always switch both live and neutral (or in a DC system + and -). **Switches MUST be located in a readily accessible location.**

Dual power supply installations must be clearly labelled and equipped with dual circuit isolators. Each isolator must be double-pole, with certified current-breaking capacity and voltage rating suitable for the cabinet version in question.

4.3.3 DC Power cables

A low impedance DC power supply should be connected to the transceiver power supply input connector (two pins only). The connector is a Phoenix type and is available from Rohill or your Rohill distributor. Use colour-coded multi-strand cable with a minimum cross-section of 2.0 mm² per transceiver for the power supply. All cables should be insulated and be strain relieved as a short circuit could cause a fire hazard. If long cables are used (>1.5m), compensate for voltage drop and protect against transients and surges. Maximum cable length 3m.

Power cables with 7/0.85 mm (4 mm²) cross section with conductors are suitable for one pair of carriers.

A cabinet with 3 or 4 carriers is designed for double cables, 2 positive and 2 negative cables because the single cable alternative would be more than twice as heavy. Supply redundancy is therefore standard for 3 and 4 carrier configurations.

4.3.4 Power supply

Ensure the power supply is capable of providing more than the rated power of the cabinet under all conditions, allowing also for turn-on surges.

If necessary protect equipment from brown-out (voltage dip), over-voltage and supply failures.

Although the power inputs are protected against transients and surges, if connecting to an alternator or generator system (especially a vehicular/generator power supply) care must be taken to provide additional filtering of noise/transients.

4.4 Network Connections

IP over Ethernet requires 50 kbps bandwidth per R-8070.

In either case, total delay to the TNX should not exceed 20ms. If it does, the system will still work, but PTT delays will be increased. Also ensure that the jitter is kept below 4 ms to minimise buffer sizes.

The IP address(es) for the transceiver can be entered via the front panel LCD.

4.5 Antenna system

4.5.1 Lightning protection



Warning:

The reader is advised to seek specialist advice on this subject¹. Rohill accepts no liability for failure of designs that may be based upon the following advice!

DO NOT WORK ON OR TOUCH ANY SYSTEM WHEN LOCAL ELECTRICAL STORM ACTIVITY IS PRESENT.

A correctly designed lightning protection system can protect a radio transmitter from the effects of most direct strikes. Adding effective protection to a system *after* initial installation can be considerably more difficult, therefore consider lightning protection requirements from the outset of system design.

Lightning protection components are not supplied as standard and are the responsibility of the antenna-site engineer.

4.5.2 Minimization of exposure to non-ionizing radiation

In Europe, in order to comply with Council Recommendation 1999/519/EC on "Limitation of exposure of the general public to electromagnetic fields (0 Hz to 300 GHz)" the following actions should be performed for every new or re-engineered transmitter site.



*Figure 9,
Non-ionizing radiation warning*

- As a minimum, the commissioning engineer should perform a calculation to show that the general public will not be exposed to electromagnetic fields in excess of the recommended levels. This calculation is to be signed and stored with the commissioning documentation file for the site. As an alternative to calculation, a measurement may be made to demonstrate compliance in which case calibration details of measuring equipment and measurement results should be recorded in the file.
- Where service/maintenance personnel require access to areas that will exceed the levels stated for exposure of the General Public, non-ionizing radiation warning signs are to be displayed (see Figure 9).

¹Polphasor Corp. have several suitable publications on this subject. E.g. The "Grounds" for Lightning and EMP Protection by Roger R. Block

4.6 BSS Configuration

The configuration of the carriers in a TetraNode BSS is fully automatic once all the necessary connections are made and the unit is powered on.

At power on, the BSS carriers announce themselves to the TNX. The R-8070 identities are captured by the TNX by means of the Plug and Play procedure. The identities are matched against system configuration database and configuration are sent to each unit. New (unknown) carriers will be automatically added to the database and made visible in the NMS.

The manual for the NMS describes the exact procedure used to configure an R-8070 carrier and also gives detailed information about the parameters.

In summary, the following parameters are sent to a BSS to configure a carrier:

- **Channel number**
(channel# = (frequency_in_MHz - Base_Frequency)/0.025)
where Base Frequency = 300, 400 or 800 MHz.
- **Transmitter output power** (dBm, 1dB steps)
- **Duplex orientation** (Tx high | Tx low), default = Tx high,
only variable for frequencies below 500MHz
- **Duplex offset**, (7 | 8 | 10 | 18 | 45)
default= 10MHz below 500MHz, otherwise 45MHz
- **Receiver selection** (enable | disable), default= all enabled
To minimise received noise and reduce power consumption, unused Rx inputs should be disabled.

The basic procedure is as follows:

1. Power-up the BSS cabinet. The R-8070s announce to the TNX but the blue Sync display marker is still off.
2. If required, a TETRA site must be created in the NMS. All parameters for the site have a default value, which is sufficient in case of a single site system. For a multi site system the parameters need to be configured to enable handovers. Make sure the site is enabled.
3. Now the R-8070 carriers must be associated with site. Fill in the carrier number and select the channel plan profile. Select the required output power and enable the receivers to be used.
4. The carrier will now become enabled. The blue Sync display marker will illuminate to indicate that the R-8070 is registered and enabled on the TX. After a timeout only the heartbeat will be shown on the display to indicate that the device is in service and ready to operate.

5 Maintenance and replacement

5.1 General

This section describes the preventive maintenance actions for the TETRA Base Station System. It also describes the replacement of the components within a BSS. Defective units are replaced as a complete unit and repaired in the factory.

5.2 Maintenance policy

There are NO end-user or distributor serviceable parts within the components of a TetraNode Base Station (such as an R-8070 or R-855 TBS-SYN). Spare parts are complete sub-rack components.

Spares holding and support requirements should be negotiated through your Rohill representative.

The network connection(s) can be used for actions such as remote download of software updates. The transceiver controller can hold multiple software versions and permits synchronised network change-over between software versions.

5.3 Maintenance

The TetraNode Base Station System is designed as a maintenance-free installation. No alignment is normally necessary during the lifetime of the equipment. Also no consumables are necessary to keep the system in operation.

Preventive maintenance should include the following checks to ensure the system is operating within specification limits. These tests can be performed from the NMS. See the NMS user manual for detailed information how to obtain the information.

- Check PA temperature (and fan speed); if this is significantly above normal limits, the airflow may be obstructed.
- Check the RF output power of the R-8070. The measured power should be within 2 dB of the selected RF output power. If the measured power is outside these limits, first check whether the problem is caused by antenna mismatch (fault). If not, the R-8070 should be replaced.
- To check for antenna system mismatch, check the reflected power. The measured reflected power should be below 30% of the selected RF output power. If the reflected power is higher, verify whether the antenna, coaxial cables, duplexer and combining equipment are working/tuned correctly.
- Check the Alarm and Failure flags. If there are any reported errors, take action to clear them as described in section Error codes R-8070.

6 Troubleshooting

6.1 General



Caution:

Service and /or maintenance of the equipment should only be carried out by qualified service technicians.

Diagnostics are performed locally or remotely with appropriate software and repair is by component replacement.

Fault find should be step by step to prove that each component of the system is operating normally. Faults can often be isolated by swapping suspect units with known good ones, however exercise care not to damage further equipment e.g. due to faulty antenna or power connections.

6.2 R-8070 Alarm messages

The R-8070 executes continuous measurements on critical parameters such as output power and level of linearization (which influences the quality of the transmitted signal). Errors are indicated by means of error codes shown on the front panel of the R-8070.

Code	Description	Possible remedy
A1	No TNX connection	1. Check TNSP (V.11) cable 2. Check if TNX / FSC is running
A2	Base station disabled	
A3	IP data link failure	1. Check IP connections 2. Check if TNX / FSC is running
A4	R-8070 disabled for maintenance	Contact distributor

Table 1, R-8070 error messages

7 Specifications

7.1 General transceiver specifications

Parameter	Specification
Manufacturer	Rohill, http://www.rohill.com
Type	R-8070
Power supply voltage	18 to 36 V _{DC} (24 V _{DC} nominal)
Power consumption per carrier (excludes ancillary site equipment)	35 W standby 180 W typical for 40W _{rms} RF output 300 W maximum
Physical dimension (WxHxD)	432 x 88 x 350 mm
Weight	9.6 kg
Operating temperature	-25 °C to +60 °C
Storage temperature	-40 °C to +85 °C
Humidity	< 95%, non condensing

Table 2, General specifications

7.2 Receiver specifications

Parameter	Specification
Rx Frequency	350-370, 380-400, 410-430, 450-470, 806-825 MHz
Duplex Spacing **	Variable 4 to 10MHz reversible below 500MHz, 45 MHz above 500MHz
Carrier Spacing	25 kHz
Frequency Offset	-6.25, 0, +6.25 or +12.5 kHz
Modulation Format	$\pi/4$ DQPSK
Channel access	4 slot TDMA
Gross Data Rate	36 kbps
Sensitivity (static)	-120 dBm (typical), minimum -119 dB
Sensitivity (dynamic)	-112 dBm (typical)
Diversity gain (static)*	two way 1.5 dB; three way 2.4 dB
Diversity gain (dynamic)*	two way > 5 dB; three way > 7.5 dB
Receiver Class	Class A (Propagation models: static, TU50, and HT200)
Dynamic Range	Max. input -10 dBm (BER 0%)
Co-channel Interference Rejection	≥ 19 dB
Adjacent channel Interference Rejection	≥ 45 dB

Table 3, Receiver specifications

* depending on antenna and environment

** all duplex splits possible within Rx and Tx band are possible subject to TETRA specification TS100 392-15

7.3 Transmitter specifications

Parameter	Specification
Tx Frequency	350-370; 380-400; 410-430; 450-470; 851-870 MHz
Duplex Spacing	Variable 4 to 10 MHz reversible, 45 MHz
Carrier Spacing	25 kHz
Frequency Offset	-6,25, 0, +6,25 or +12,5 kHz
Modulation Format	$\pi/4$ DQPSK
Data Rate	36 kbps
ITU Emission Designation	18K0 G7W
Max Tx Output Power	33 - 46 dBm (2.0 – 40 W_{rms}) adjustable in 1 dB steps
Tx Power Tolerance	± 1.0 dB (TETRA specification: ± 2.0 dB normal conditions)
Frequency Error	With TBS-SYN: GPS stability, without GPS: < 0.02 ppm below 700MHz <0.01ppm above 700MHz)
Transmit Intermodulation Attenuation	Single TBS / site: < -40 dBc Multiple TBS / site: < -70 dBc (with single isolator)
Transmitter Modulation Accuracy	RMS vector error: < 10% in any burst Peak vector error magnitude: < 30% for any symbol
Residual Carrier Magnitude	< 5% of the magnitude of the modulation symbol
VSWR of Output	< 1.4:1
Max. VSWR of load	< 3: continuous operation > 3: transmit power turned off + warning Maximum VSWR: 20

Table 4, Transmitter specifications