

# FCC CERTIFICATION TEST REPORT

## FOR

<b>Applicant</b>	:	Guangdong Hisense Broadband Technology Co., Ltd
<b>Address</b>	:	No.8 Hisense Road, Tangxia Town, Pengjiang District, Jiangmen City, Guangdong Province
<b>Equipment under Test</b>	:	GPON SFU ONT
<b>Model No.</b>	:	7285G
<b>Trade Mark</b>	:	iPhotonix, CORNING, Hisense
<b>FCC ID</b>	:	2AGHCHBMT07
<b>Manufacturer</b>	:	Guangdong Hisense Broadband Technology Co., Ltd
<b>Address</b>	:	No.8 Hisense Road, Tangxia Town, Pengjiang District, Jiangmen City, Guangdong Province

**Issued By: Dongguan Dongdian Testing Service Co., Ltd.**

**Add:** No. 17, Zongbu Road 2, Songshan Lake Sci&Tech, Industry Park,  
Dongguan City, Guangdong Province, China, 523808

**Tel:** +86-0769-89201699, **E-mail:** ddt@dgddt.com, <http://www.dgddt.com>

# REPORT

## TABLE OF CONTENTS

	Test report declares.....	4
1.	Summary of test results .....	6
2.	General test information .....	7
2.1.	Description of EUT.....	7
2.2.	Accessories of EUT .....	7
2.3.	Assistant equipment used for test.....	7
2.4.	Block diagram of EUT configuration for test .....	8
2.5.	Deviations of test standard .....	8
2.6.	Test environment conditions .....	9
2.7.	Test laboratory.....	9
2.8.	Measurement uncertainty .....	9
3.	Equipment used during test .....	10
4.	6/26dB Bandwidth.....	11
4.1.	Block diagram of test setup .....	11
4.2.	Limits .....	11
4.3.	Test Procedure .....	11
4.4.	Test Result .....	12
4.5.	Original test data.....	14
5.	Maximum Output Power .....	50
5.1.	Block diagram of test setup .....	50
5.2.	Limits .....	50
5.3.	Test Procedure .....	50
5.4.	Test Result .....	50
5.5.	Original test data.....	53
6.	Power Spectral Density .....	89
6.1.	Block diagram of test setup .....	89
6.2.	Limits .....	89
6.3.	Test Procedure .....	89
6.4.	Test Result .....	90
6.5.	Original test data.....	93
7.	Frequency Stability Measurement .....	129
7.1.	Limit of Frequency Stability.....	129
7.2.	Measuring Instruments .....	129
7.3.	Test Procedures .....	129
7.4.	Test Setup .....	129
7.5.	Test Result .....	129
8.	Emissions in restricted frequency bands .....	147

- 8.1. Block diagram of test setup ..... 147
- 8.2. Limit ..... 148
- 8.3. Test Procedure ..... 149
- 8.4. Test result ..... 151
- 9. Band Edge Compliance ..... 157
- 9.1. Block diagram of test setup ..... 157
- 9.2. Limit ..... 157
- 9.3. Test Procedure ..... 157
- 9.4. Test result ..... 158
- 10. Power Line Conducted Emission ..... 177
- 10.1. Block diagram of test setup ..... 177
- 10.2. Power Line Conducted Emission Limits(Class B) ..... 177
- 10.3. Test Procedure ..... 177
- 10.4. Test Result ..... 178
- 11. Antenna Requirements ..... 181
- 11.1. Limit ..... 181
- 11.2. Result ..... 181

## TEST REPORT DECLARE

<b>Applicant</b>	:	Guangdong Hisense Broadband Technology Co., Ltd
<b>Address</b>	:	No.8 Hisense Road, Tangxia Town, Pengjiang District, Jiangmen City, Guangdong Province
<b>Equipment under Test</b>	:	GPON SFU ONT
<b>Model No</b>	:	7285G
<b>Trade Mark</b>	:	iPhotonix, CORNING, Hisense
<b>Manufacturer</b>	:	Guangdong Hisense Broadband Technology Co., Ltd
<b>Address</b>	:	No.8 Hisense Road, Tangxia Town, Pengjiang District, Jiangmen City, Guangdong Province

**Test Standard Used:** FCC Rules and Regulations Part 15 Subpart E

**Test procedure used:** ANSI C63.10:2013, 789033 D02 General UNII Test Procedures New Rules v01

**We Declare:**

The equipment described above is tested by Dongguan Dongdian Testing Service Co., Ltd and in the configuration tested the equipment complied with the standards specified above. The test results are contained in this test report and Dongguan Dongdian Testing Service Co., Ltd is assumed of full responsibility for the accuracy and completeness of these tests.

**After test and evaluation, our opinion is that the equipment provided for test compliance with the requirement of the above FCC&IC standards.**

<b>Report No:</b>	DDT-R18030203-1E2		
<b>Date of Receipt:</b>	Mar. 06, 2018	<b>Date of Test:</b>	Mar. 06, 2018 ~ Apr. 24, 2018

**Prepared By:**

*Sam Li*

**Sam Li/Engineer**

**Approved By:**



**Kevin Feng/EMC Manager**

Note: This report applies to above tested sample only. This report shall not be reproduced in parts without written approval of Dongguan Dongdian Testing Service Co., Ltd.

### Revision history

Rev.	Revisions	Issue Date	Revised By
---	Initial issue	Apr. 24, 2018	

## 1. Summary of test results

The EUT have been tested according to the applicable standards as referenced below.		
Description of Test Item	Standard	Results
6/26db Bandwidth	FCC 15.407 (e)	PASS
Maximum Conducted Output Power	FCC 15.407 (a)	PASS
Power Spectral Density	FCC 15.407 (a)	PASS
Frequency Stability Measurement	FCC 15.407 (g)	PASS
Emissions in restricted frequency bands	FCC 15.407 (a) FCC 15.209 FCC 15.205	PASS
Band Edge Compliance	FCC 15.407 (a) FCC 15.209 FCC 15.205	PASS
Power Line Conducted Emission	FCC 15.207	PASS
Antenna requirement	FCC 15.203	PASS
Dynamic Frequency Selection	FCC 15.407 (h)	N/A

N/A is an abbreviation for Not Applicable.

## 2. General test information

### 2.1. Description of EUT

EUT* Name	: GPON SFU ONT
Model Number	: 7285G
EUT function description	: Please reference user manual of this device
Power supply	: DC 12V from external AC Adapter
Radio Technology	: IEEE802.11n/a/ac
Operation frequency	: IEEE 802.11a: 5180MHz-5240MHz, 5745MHz-5825MHz IEEE 802.11n HT20: 5180MHz-5240MHz, 5745MHz-5825MHz IEEE 802.11n HT40: 5190MHz-5230MHz, 5755MHz-5795MHz IEEE 802.11ac HT20: 5180MHz-5240MHz, 5745MHz-5825MHz IEEE 802.11ac HT40: 5190MHz-5230MHz, 5755MHz-5795MHz IEEE 802.11ac HT80: 5210MHz, 5775MHz
Modulation	: IEEE 802.11a: OFDM (64QAM, 16QAM, QPSK, BPSK) IEEE 802.11n: OFDM (64QAM, 16QAM, QPSK, BPSK) IEEE 802.11ac: OFDM (256QAM, 64QAM, 16QAM, QPSK, BPSK)
Transmitter rate	: IEEE 802.11a: 6, 9, 12, 18, 24, 36, 48, 54 Mbps IEEE 802.11n HT20: up to 150 Mbps, HT40: up to 300 Mbps IEEE 802.11ac VHT20: up to 150 Mbps, VHT40: up to 300 Mbps VHT80: up to 886.7 Mbps
Antenna Type	: External PCB antenna 1: 5G band maximum PK gain 3.89dBi Integrated metal antenna 2: 5G band maximum PK gain 3.85dBi Integrated metal antenna 3: 5G band maximum PK gain 4.17dBi
Sample Type	: Series production

Note: EUT is the ab. of equipment under test.

Antenna information				
	Ant1 gain	Ant2 gain	Ant3 gain	MIMO
IEEE 802.11a	3.89	/	/	/
IEEE 802.11n HT20	3.89	3.85	4.17	8.74
IEEE 802.11n HT40	3.89	3.85	4.17	8.74
IEEE 802.11ac VHT20	3.89	3.85	4.17	8.74
IEEE 802.11ac VHT40	3.89	3.85	4.17	8.74
IEEE 802.11ac VHT80	3.89	3.85	4.17	8.74

### 2.2. Accessories of EUT

Description of Accessories	Manufacturer	Model number	Serial No.	Other
AC Adapter	N/A	RD1201500-C55-24 MG	N/A	Input: AC 100-240V -50/60Hz, 0.6A; Output: DC 12V, 1.5A; Length: 1.60m

### 2.3. Assistant equipment used for test

Assistant equipment	Manufacturer	Model number	EMC Compliance	SN
Notebook	DELL	Latitude D610	FCC DOC	00045-534-136-300

## 2.4. Block diagram of EUT configuration for test



EUT was connected to control to provided by manufacturer which has a standard LAN PORT connector to connect to Notebook, and the Notebook will run “CMD telnet” to control EUT work in Continuous Tx mode, and select test channel, wireless mode and data rate.

Tested mode, channel, and data rate information				
Mode	Setting Tx Power	data rate (Mbps) (see Note)	Channel	Frequency (MHz)
IEEE 802.11a	/	54	Low :CH36	5180
	/	54	Middle: CH40	5200
	/	54	High: CH48	5240
	/	54	Low :CH149	5745
	/	54	Middle: CH157	5785
	/	54	High: CH165	5825
IEEE 802.11n HT20	/	MCS 7	Low :CH36	5180
	/	MCS 7	Middle: CH40	5200
	/	MCS 7	High: CH48	5240
	/	MCS 7	Low :CH149	5745
	/	MCS 7	Middle: CH157	5785
	/	MCS 7	High: CH165	5825
IEEE 802.11n HT40	/	MCS 7	Low :CH36	5190
	/	MCS 7	High: CH44	5230
	/	MCS 7	Low: CH149	5755
	/	MCS 7	High: CH157	5795
IEEE 802.11ac VHT20	/	MCS 7	Low :CH36	5180
	/	MCS 7	Middle: CH40	5200
	/	MCS 7	High: CH48	5240
	/	MCS 7	Low :CH149	5745
	/	MCS 7	Middle: CH157	5785
	/	MCS 7	High: CH165	5825
IEEE 802.11ac VHT40	/	MCS 8	Low :CH36	5190
	/	MCS 8	High: CH44	5230
	/	MCS 8	Low: CH149	5755
	/	MCS 8	High: CH157	5795
IEEE 802.11ac VHT80	/	MCS 9	CH36	5210
	/	MCS 9	CH149	5775

Note: According exploratory test, EUT will have maximum output power in those data rate, so those data rate were used for all test.

## 2.5. Deviations of test standard

No Deviation.



## 2.6. Test environment conditions

During the measurement the environmental conditions were within the listed ranges:

Temperature range:	21-25℃
Humidity range:	40-75%
Pressure range:	86-106kPa

## 2.7. Test laboratory

Dongguan Dongdian Testing Service Co., Ltd

Add: No. 17, Zongbu Road 2, Songshan Lake Sci&Tech, Industry Park, Dongguan City, Guangdong Province, China, 523808

Tel: +86-0769-89201699, <http://www.dgddt.com>, Email: [ddt@dgddt.com](mailto:ddt@dgddt.com)

CNAS Accreditation No. L6451; A2LA Accreditation No. 3870.01

Designation Number: CN1182; Test Firm Registration Number: 540522

Industry Canada site registration number: 10288A-1

## 2.8. Measurement uncertainty

Test Item	Uncertainty
Bandwidth	1.1%
Peak Output Power(Conducted)(Spectrum analyzer)	0.86dB (10 MHz ≤ f < 3.6GHz); 1.38dB (3.6GHz ≤ f < 8GHz)
Peak Output Power(Conducted)(Power Sensor)	0.74dB
Power Spectral Density	0.74dB (10 MHz ≤ f < 3.6GHz); 1.38dB (3.6GHz ≤ f < 8GHz)
Frequencies Stability	6.7 × 10 <sup>-8</sup> (Antenna couple method) 5.5 × 10 <sup>-8</sup> (Conducted method)
Conducted spurious emissions	0.86dB (10 MHz ≤ f < 3.6GHz); 1.40dB (3.6GHz ≤ f < 8GHz) 1.66dB (8GHz ≤ f < 22GHz)
Uncertainty for radio frequency (RBW<20kHz)	3×10 <sup>-8</sup>
Temperature	0.4℃
Humidity	2%
Uncertainty for Radiation Emission test (30MHz-1GHz)	4.70 dB (Antenna Polarize: V) 4.84 dB (Antenna Polarize: H)
Uncertainty for Radiation Emission test (1GHz-40GHz)	4.10dB (1-6GHz) 4.40dB (6GHz-18GHz) 3.54dB (18GHz-26GHz) 4.30dB (26GHz-40GHz)
Uncertainty for Power line conduction emission test	3.32dB (150kHz-30MHz)
Note: This uncertainty represents an expanded uncertainty expressed at approximately the 95% confidence level using a coverage factor of k=2.	

### 3. Equipment used during test

Equipment	Manufacturer	Model No.	Serial No.	Last Cal.	Cal. Interval
<b>RF Connected Test (Tonscend RF Measurement System)</b>					
Spectrum analyzer	R&S	FSU26	200071	Oct. 23, 2017	1 Year
Spectrum analyzer	Agilent	E4447A	MY50180031	Jun. 16, 2017	1 Year
Wideband Radio Communication tester	R&S	CMW500	117491	Jun. 16, 2017	1 Year
Vector Signal Generator	Agilent	E8267D	US49060192	Oct. 23, 2017	1 Year
Vector Signal Generator	Agilent	N5182A	MY48180737	Jun.16, 2017	1 Year
Power Sensor	Agilent	U2021XA	MY55150010	Oct. 21, 2017	1 Year
Power Sensor	Agilent	U2021XA	MY55150011	Oct. 23, 2017	1 Year
DC Power Source	MATRIS	MPS-3005L-3	D813058W	Aug. 18, 2017	1 Year
Attenuator	Mini-Circuits	BW-S10W2	101109	Aug. 18, 2017	1 Year
RF Cable	Micable	C10-01-01-1	100309	Oct. 21, 2017	1 Year
Temp&Humi Programmable	ZHIXIANG	ZXGDJS-150 L	ZX170110-A	Oct. 21, 2017	1 Year
Test Software	JS Tonscend	JS1120-3	Ver.2.7	N/A	N/A
<b>Radiated Emission Test Chamber 1#</b>					
EMI Test Receiver	R&S	ESU8	100316	Oct. 21, 2017	1 Year
Spectrum analyzer	Agilent	E4447A	MY50180031	Jun. 16, 2017	1 Year
Trilog Broadband Antenna	Schwarzbeck	VULB9163	9163-462	Nov. 09, 2017	1 Year
Active Loop antenna	Schwarzbeck	FMZB-1519	1519-038	Oct. 17, 2017	1 Year
Double Ridged Horn Antenna	R&S	HF907	100276	Oct. 17, 2017	1 Year
Broad Band Horn Antenna	Schwarzbeck	BBHA 9170	790	Nov. 09, 2017	1 Year
Pre-amplifier	A.H.	PAM-0118	360	Oct. 21, 2017	1 Year
Pre-amplifier	TERA-MW	TRLA-0040G35	101303	Oct. 21, 2017	1 Year
RF Cable	HUBSER	CP-X2+ CP-X1	W11.03+ W12.02	Oct. 21, 2017	1 Year
RF Cable	N/A	SMAJ-SMAJ-1M+ 11M	17070133+17070131	Nov. 08, 2017	1 Year
MI Cable	HUBSER	C10-01-01-1 M	1091629	Oct. 21, 2017	1 Year
Test software	Audix	E3	V 6.11111b	N/A	N/A
<b>Power Line Conducted Emissions Test</b>					
Test Receiver	R&S	ESPI	101761	Oct. 21, 2017	1 Year
LISN 1	R&S	ENV216	101109	Oct. 21, 2017	1 Year
LISN 2	R&S	ESH2-Z5	100309	Oct. 21, 2017	1 Year
Pulse Limiter	R&S	ESH3-Z2	101242	Oct. 21, 2017	1 Year
CE Cable 1	HUBSER	N/A	W10.01	Oct. 21, 2017	1 Year
Test software	Audix	E3	V 6.11111b	N/A	N/A

## 4. 6/26dB Bandwidth

### 4.1. Block diagram of test setup

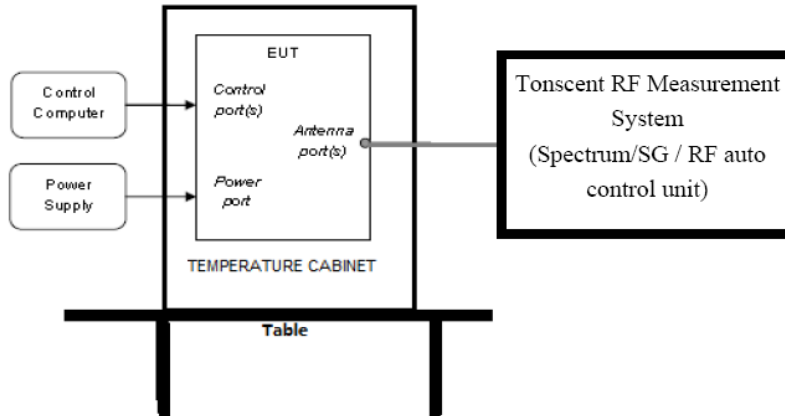

### 4.2. Limits

FCC Part15, Subpart E		
Test Item	Limit	Frequency Range (MHz)
Bandwidth	26 dB Bandwidth	5150-5250
	Minimum 500kHz 6dB Bandwidth	5725-5850

### 4.3. Test Procedure

(1) Connect EUT's antenna output to spectrum analyzer by RF cable.

Center Frequency	The centre frequency of the channel under test
Detector	Peak
RBW	For 6dB Bandwidth: RBW=300kHz For 26dB Bandwidth: approximately 1% of the emission bandwidth.
VBW	For 6dB Bandwidth : VBW=1MHz For 26dB Bandwidth : >3RBW
Trace	Max hold
Sweep	Auto couple

(2) Allow the trace to stabilize, measure the maximum width of the emission that is constrained by the frequencies associated with the two outermost amplitude points (upper and lower frequencies) that are attenuated by 26 dB or 6dB relative to the maximum level measured in the fundamental emission.

#### 4.4. Test Result

Test Mode	Antenna	Test Channel	EBW[MHz]	Limit[MHz]	Verdict
11N20MIMO	ANT1	5180	20.550	---	PASS
11N20MIMO	ANT2	5180	20.400	---	PASS
11N20MIMO	ANT3	5180	21.660	---	PASS
11N20MIMO	ANT1	5200	20.550	---	PASS
11N20MIMO	ANT2	5200	20.400	---	PASS
11N20MIMO	ANT3	5200	20.550	---	PASS
11N20MIMO	ANT1	5240	20.520	---	PASS
11N20MIMO	ANT2	5240	20.400	---	PASS
11N20MIMO	ANT3	5240	20.520	---	PASS
11N20MIMO	ANT1	5745	17.670	0.5	PASS
11N20MIMO	ANT2	5745	17.790	0.5	PASS
11N20MIMO	ANT3	5745	17.820	0.5	PASS
11N20MIMO	ANT1	5785	17.820	0.5	PASS
11N20MIMO	ANT2	5785	17.760	0.5	PASS
11N20MIMO	ANT3	5785	17.700	0.5	PASS
11N20MIMO	ANT1	5825	17.820	0.5	PASS
11N20MIMO	ANT2	5825	17.760	0.5	PASS
11N20MIMO	ANT3	5825	17.940	0.5	PASS
11N40MIMO	ANT1	5190	44.340	---	PASS
11N40MIMO	ANT2	5190	39.960	---	PASS
11N40MIMO	ANT3	5190	46.380	---	PASS
11N40MIMO	ANT1	5230	46.440	---	PASS
11N40MIMO	ANT2	5230	40.020	---	PASS
11N40MIMO	ANT3	5230	44.400	---	PASS
11N40MIMO	ANT1	5755	36.420	0.5	PASS
11N40MIMO	ANT2	5755	36.720	0.5	PASS
11N40MIMO	ANT3	5755	36.660	0.5	PASS
11N40MIMO	ANT1	5795	36.660	0.5	PASS
11N40MIMO	ANT2	5795	36.780	0.5	PASS
11N40MIMO	ANT3	5795	36.600	0.5	PASS
11AC20MIMO	ANT1	5180	20.640	---	PASS
11AC20MIMO	ANT2	5180	20.430	---	PASS
11AC20MIMO	ANT3	5180	20.520	---	PASS
11AC20MIMO	ANT1	5200	20.670	---	PASS
11AC20MIMO	ANT2	5200	20.580	---	PASS
11AC20MIMO	ANT3	5200	20.670	---	PASS

11AC20MIMO	ANT1	5240	20.490	---	PASS
11AC20MIMO	ANT2	5240	20.520	---	PASS
11AC20MIMO	ANT3	5240	20.610	---	PASS
11AC20MIMO	ANT1	5745	17.850	0.5	PASS
11AC20MIMO	ANT2	5745	17.910	0.5	PASS
11AC20MIMO	ANT3	5745	17.880	0.5	PASS
11AC20MIMO	ANT1	5785	17.790	0.5	PASS
11AC20MIMO	ANT2	5785	17.730	0.5	PASS
11AC20MIMO	ANT3	5785	17.760	0.5	PASS
11AC20MIMO	ANT1	5825	17.970	0.5	PASS
11AC20MIMO	ANT2	5825	17.820	0.5	PASS
11AC20MIMO	ANT3	5825	17.880	0.5	PASS
11AC40MIMO	ANT1	5190	40.020	---	PASS
11AC40MIMO	ANT2	5190	39.840	---	PASS
11AC40MIMO	ANT3	5190	42.360	---	PASS
11AC40MIMO	ANT1	5230	40.140	---	PASS
11AC40MIMO	ANT2	5230	39.840	---	PASS
11AC40MIMO	ANT3	5230	40.080	---	PASS
11AC40MIMO	ANT1	5755	36.480	0.5	PASS
11AC40MIMO	ANT2	5755	36.540	0.5	PASS
11AC40MIMO	ANT3	5755	36.600	0.5	PASS
11AC40MIMO	ANT1	5795	36.540	0.5	PASS
11AC40MIMO	ANT2	5795	36.660	0.5	PASS
11AC40MIMO	ANT3	5795	36.480	0.5	PASS
11AC80MIMO	ANT1	5210	80.480	---	PASS
11AC80MIMO	ANT2	5210	80.000	---	PASS
11AC80MIMO	ANT3	5210	80.960	---	PASS
11AC80MIMO	ANT1	5775	76.320	0.5	PASS
11AC80MIMO	ANT2	5775	76.800	0.5	PASS
11AC80MIMO	ANT3	5775	76.640	0.5	PASS
11ASISO	ANT1	5180	20.340	---	PASS
11ASISO	ANT1	5200	20.250	---	PASS
11ASISO	ANT1	5240	20.340	---	PASS
11ASISO	ANT1	5745	16.470	0.5	PASS
11ASISO	ANT1	5785	16.500	0.5	PASS
11ASISO	ANT1	5825	16.500	0.5	PASS

### 4.5. Original test data

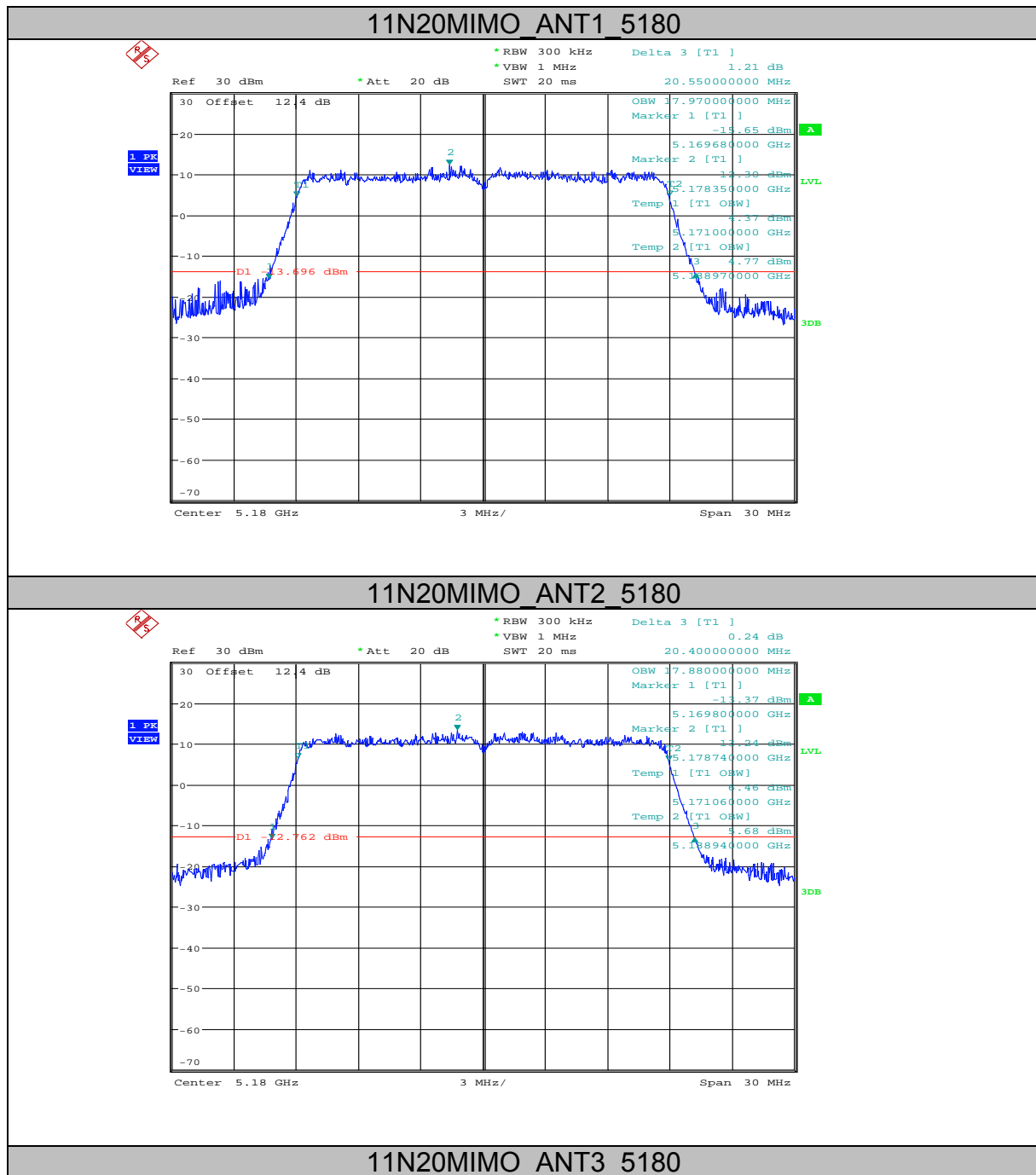

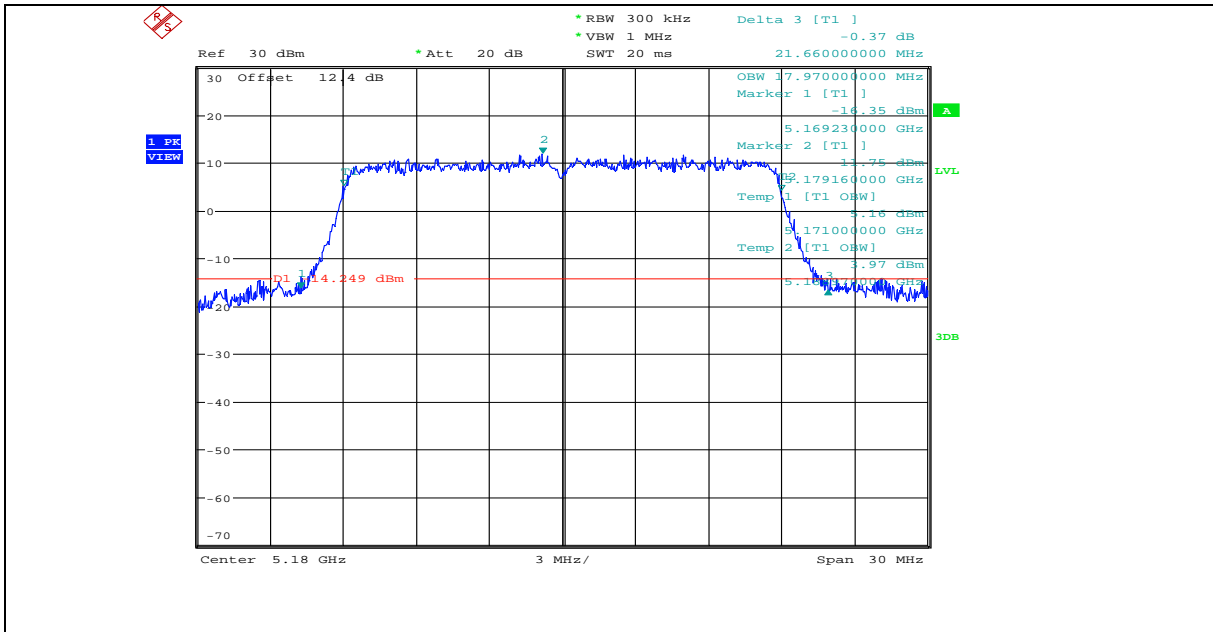

11N20MIMO\_ANT1\_5200

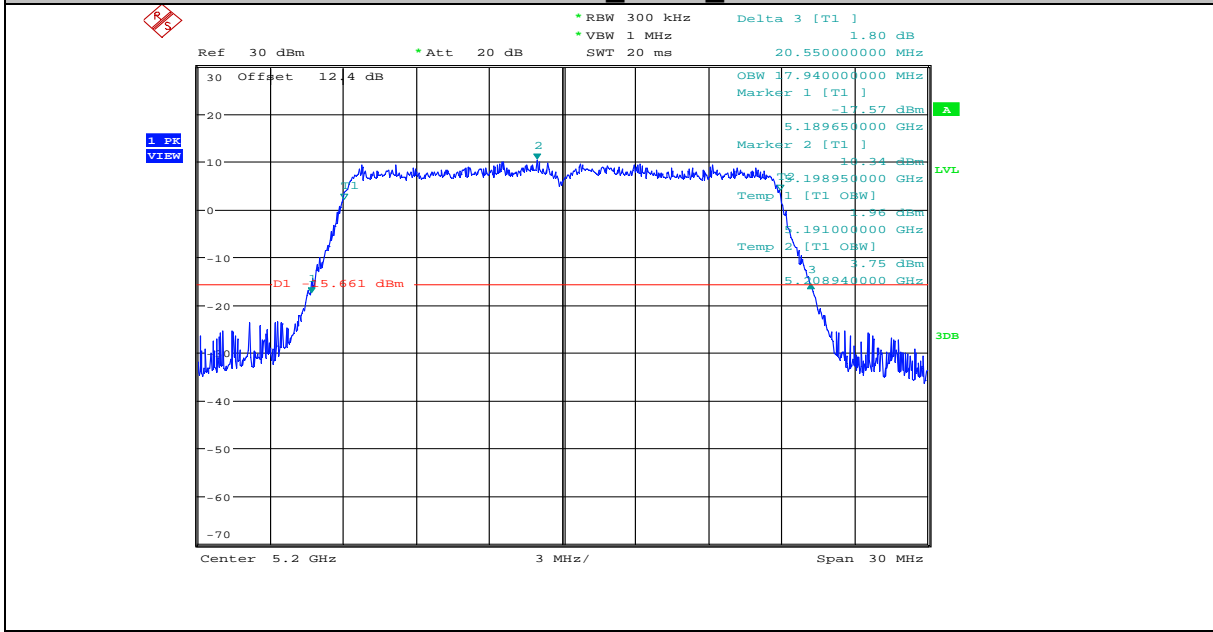

11N20MIMO\_ANT2\_5200

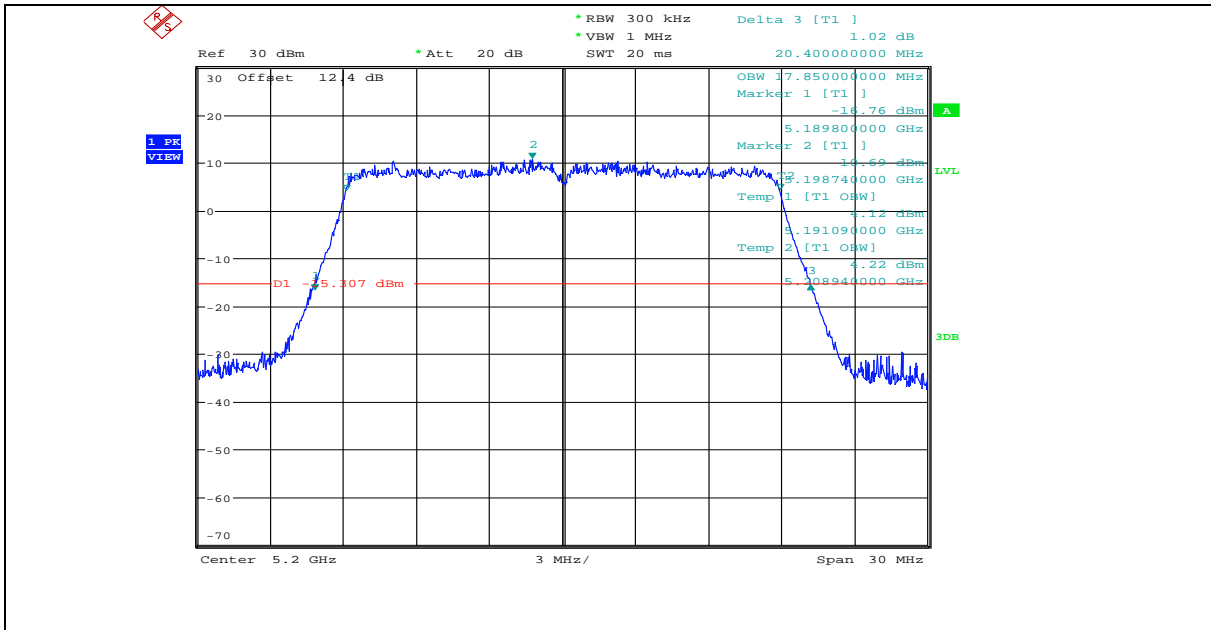

11N20MIMO\_ANT3\_5200

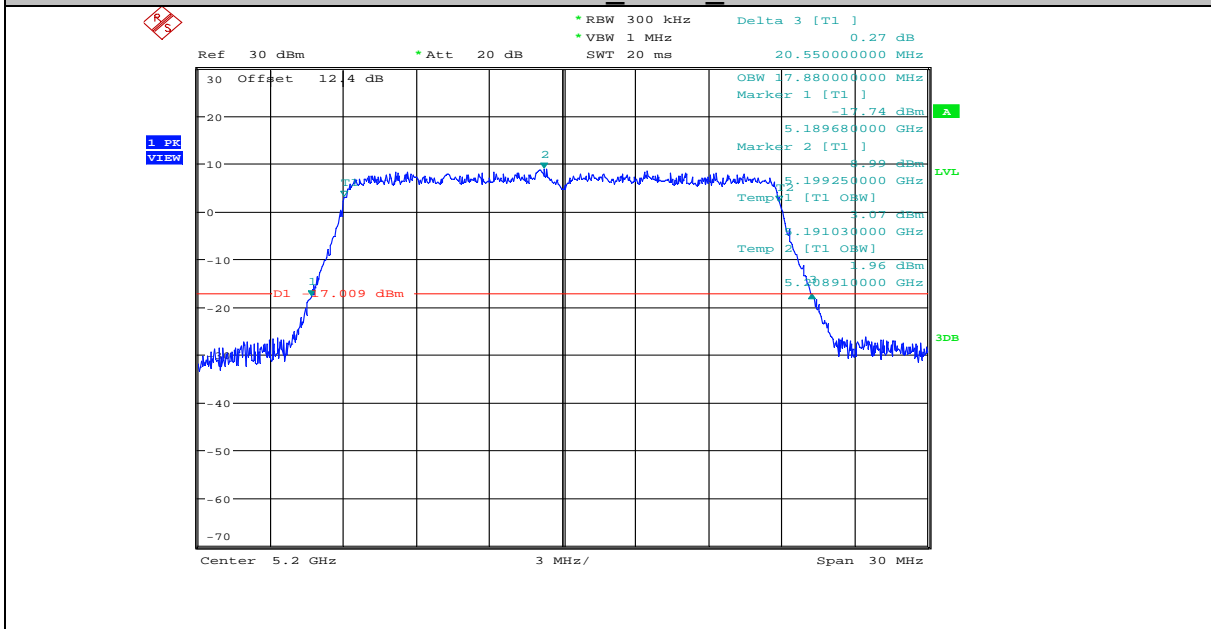

11N20MIMO\_ANT1\_5240



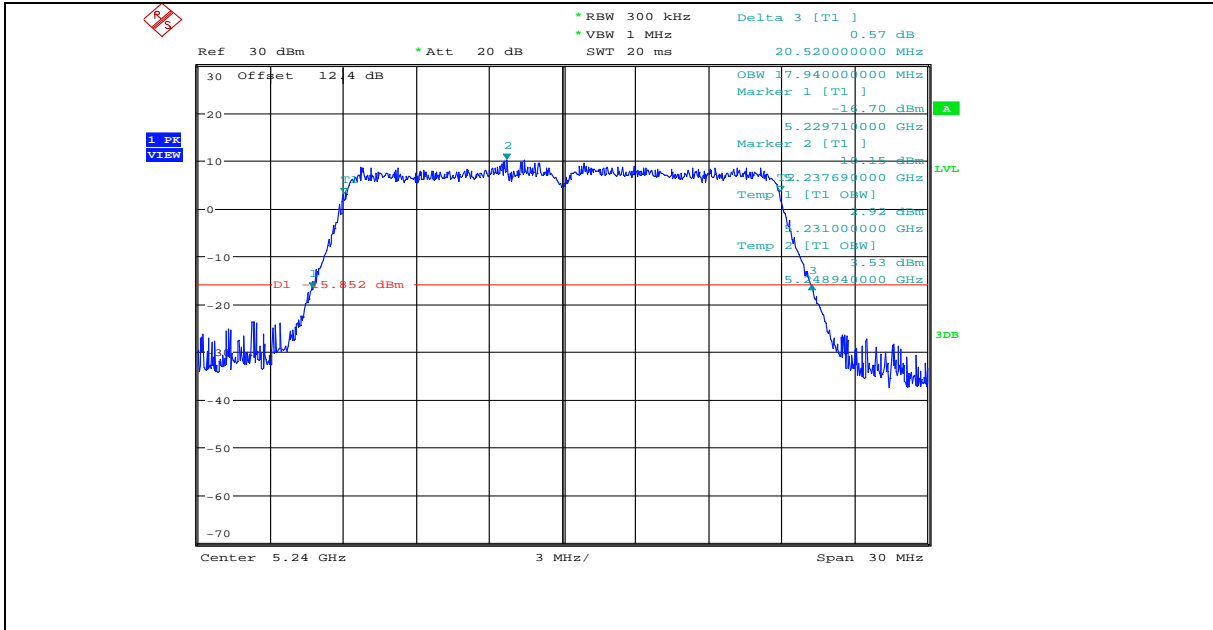

11N20MIMO\_ANT2\_5240

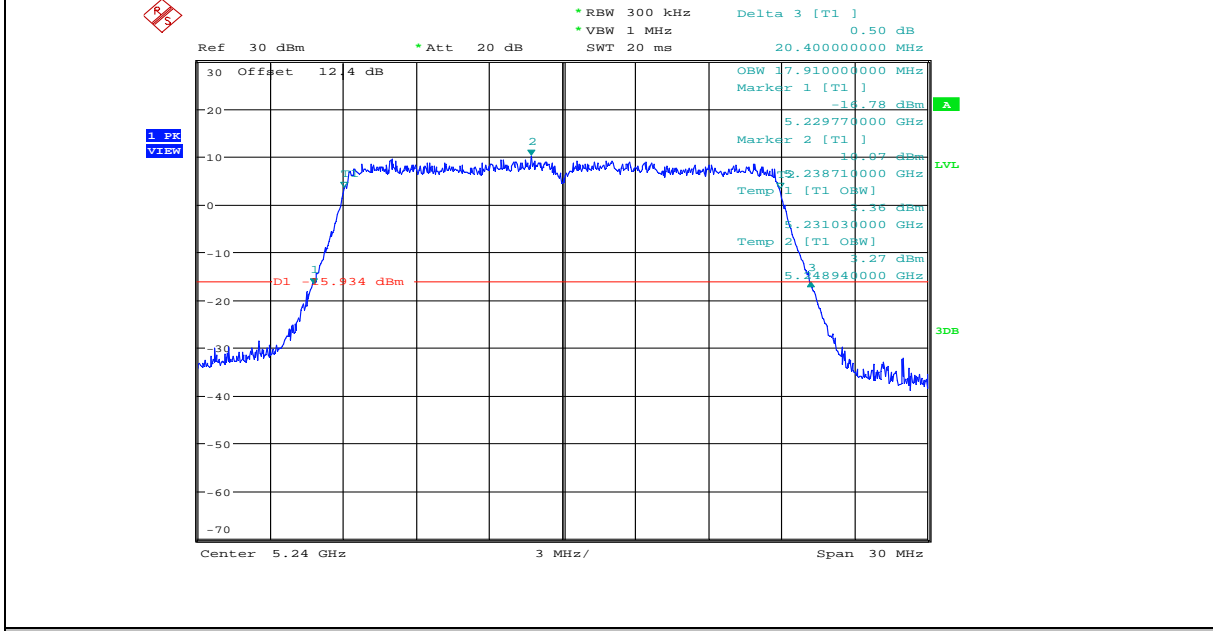

11N20MIMO\_ANT3\_5240

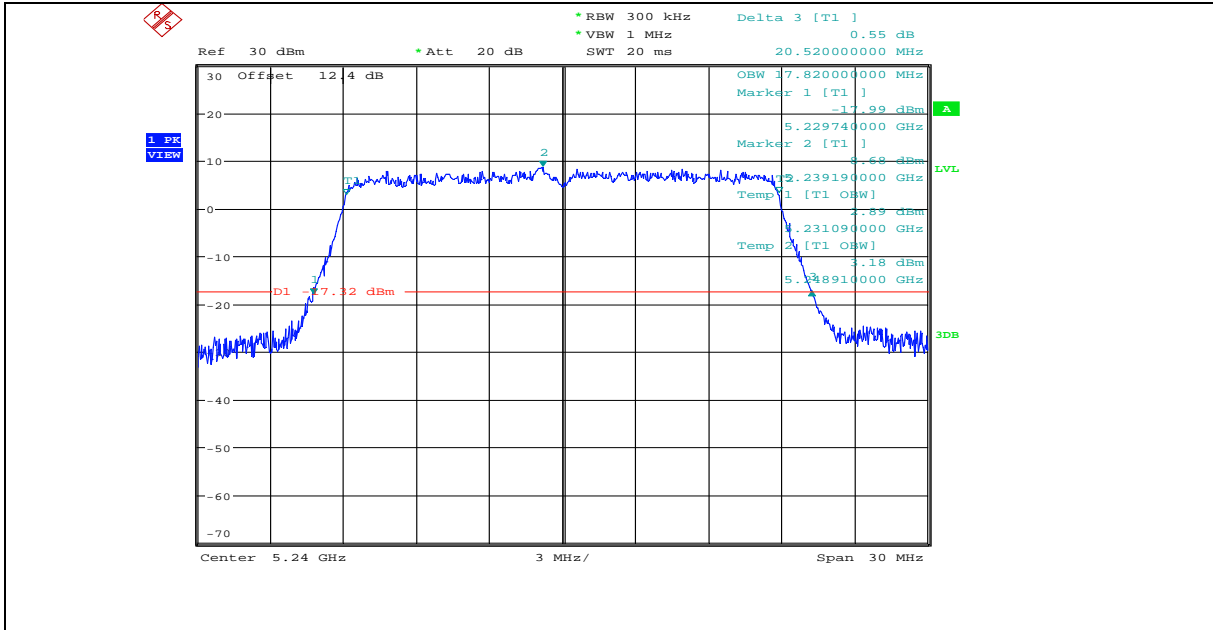

11N20MIMO ANT1 5745

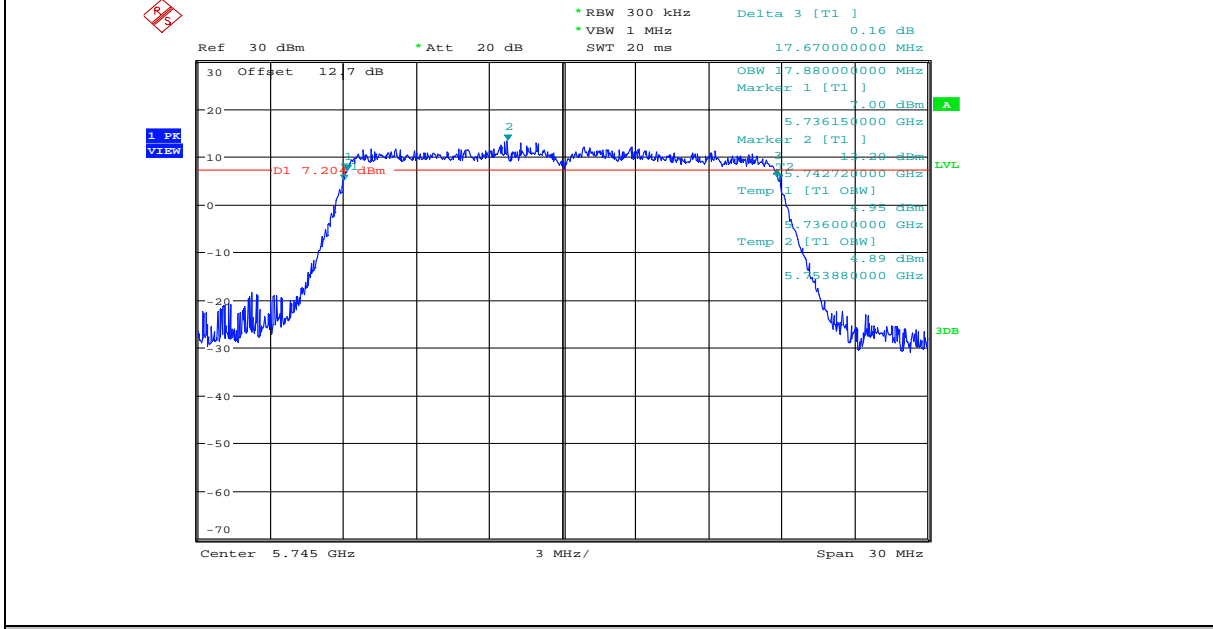

11N20MIMO ANT2 5745

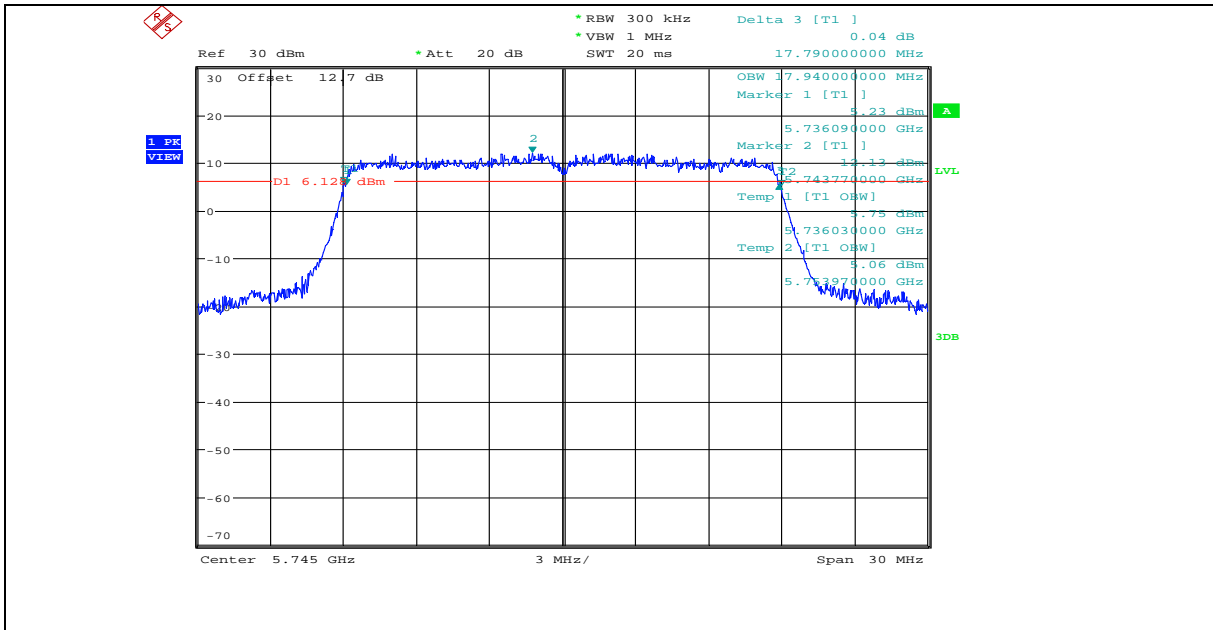

11N20MIMO\_ANT3\_5745

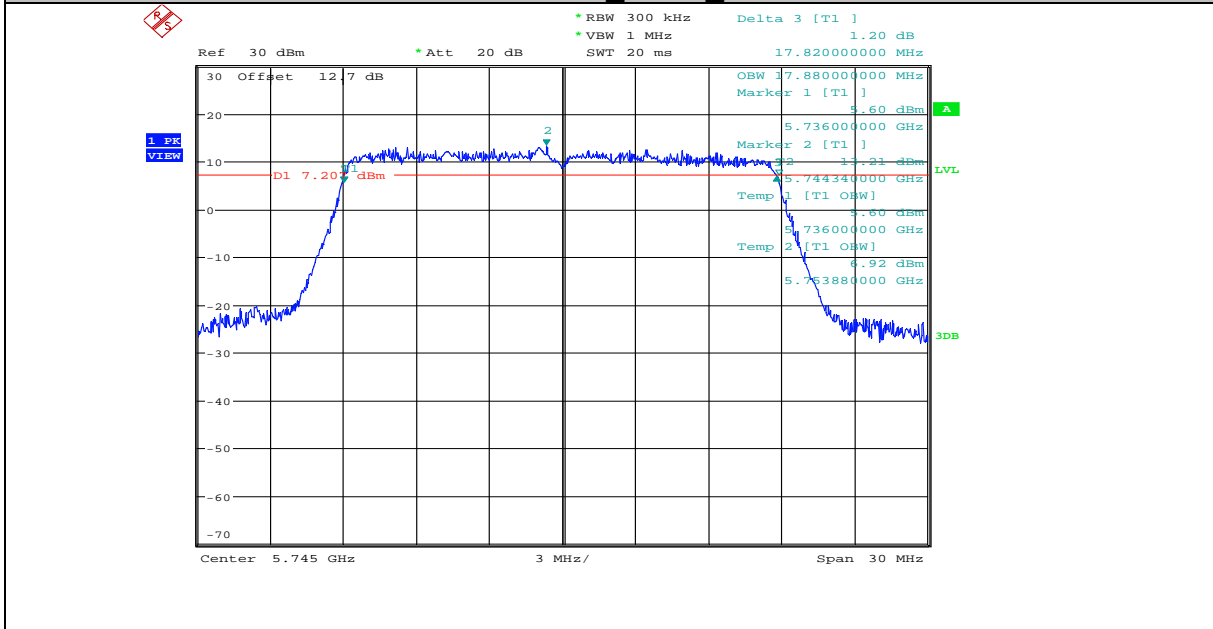

11N20MIMO\_ANT1\_5785

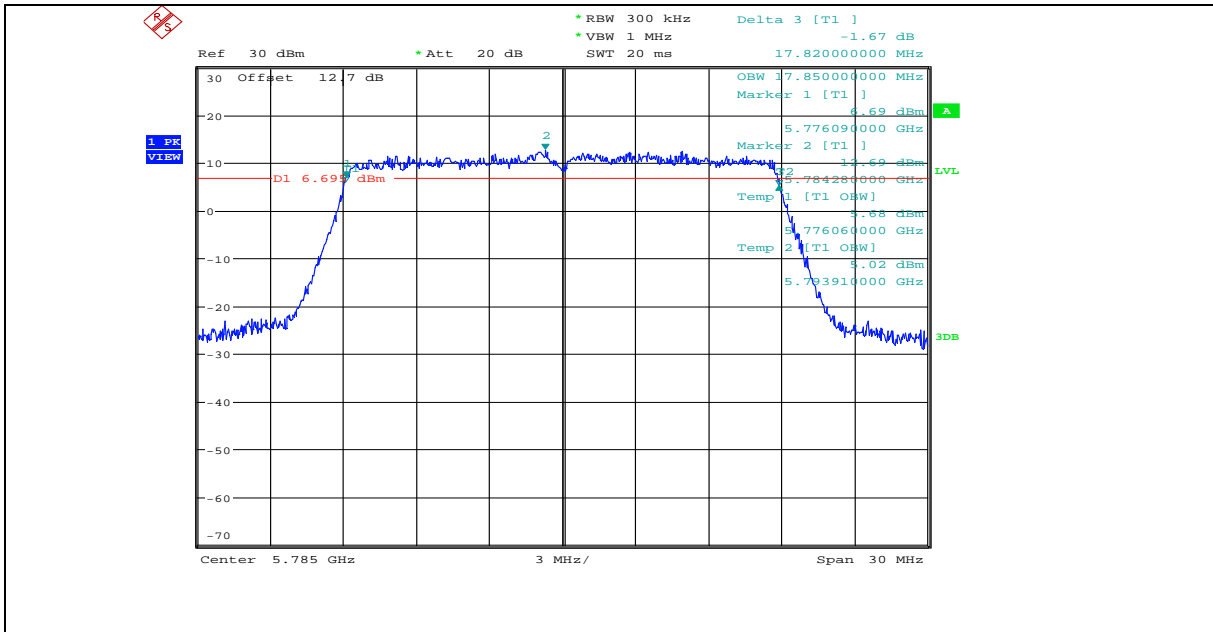

11N20MIMO ANT2 5785

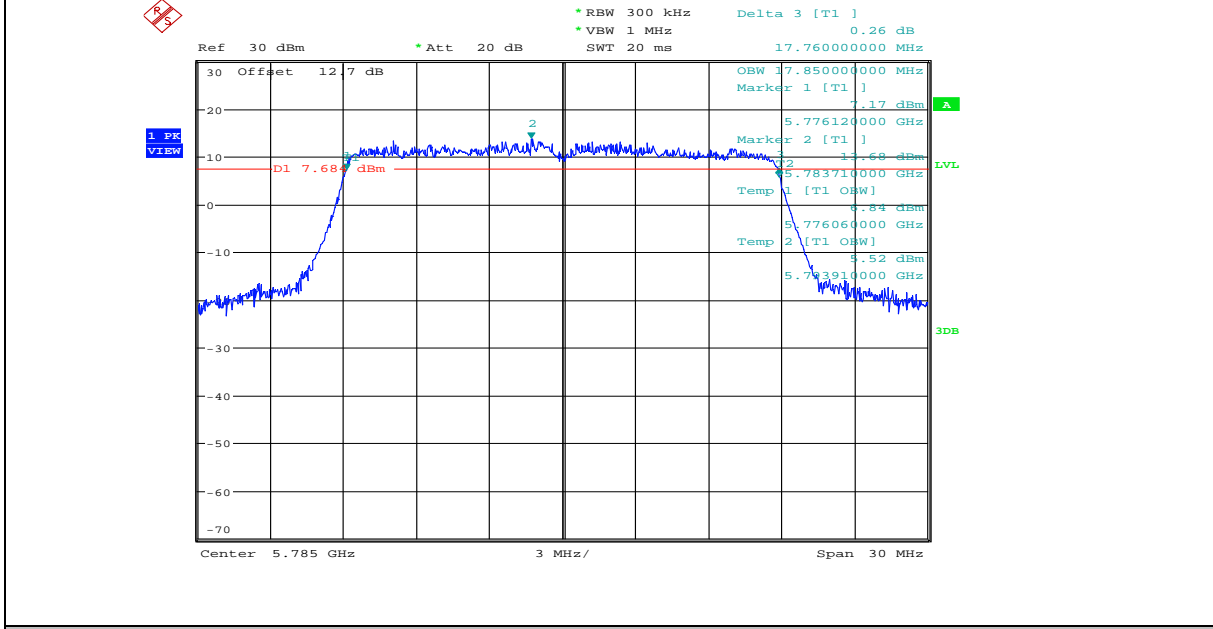

11N20MIMO ANT3 5785

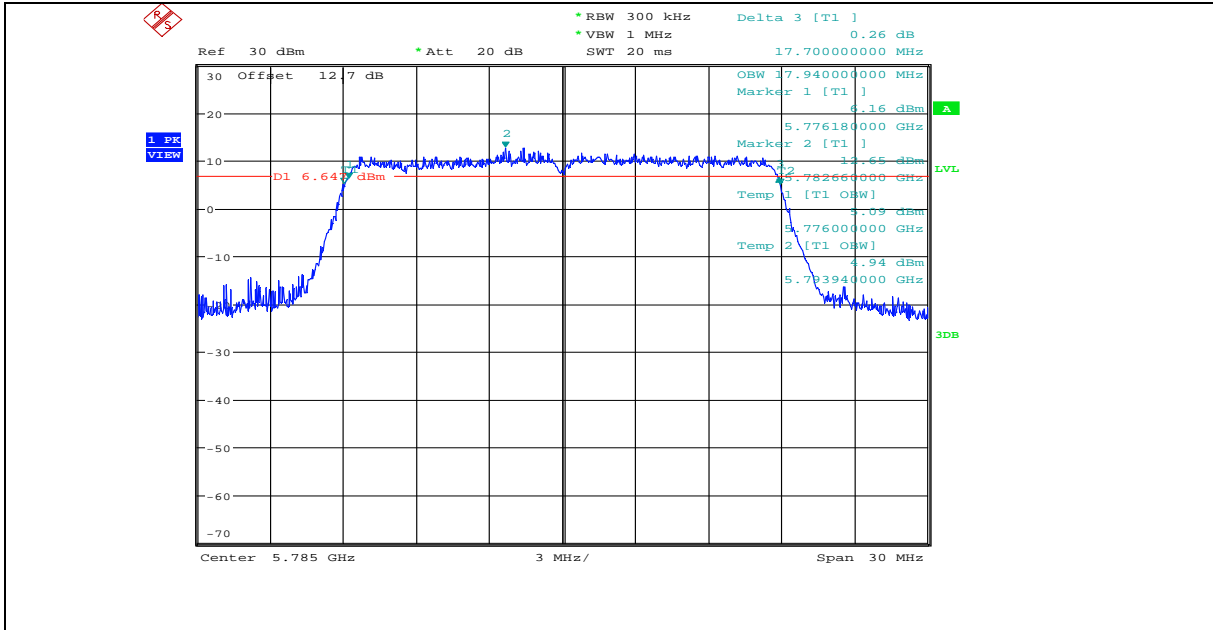

11N20MIMO\_ANT1\_5825

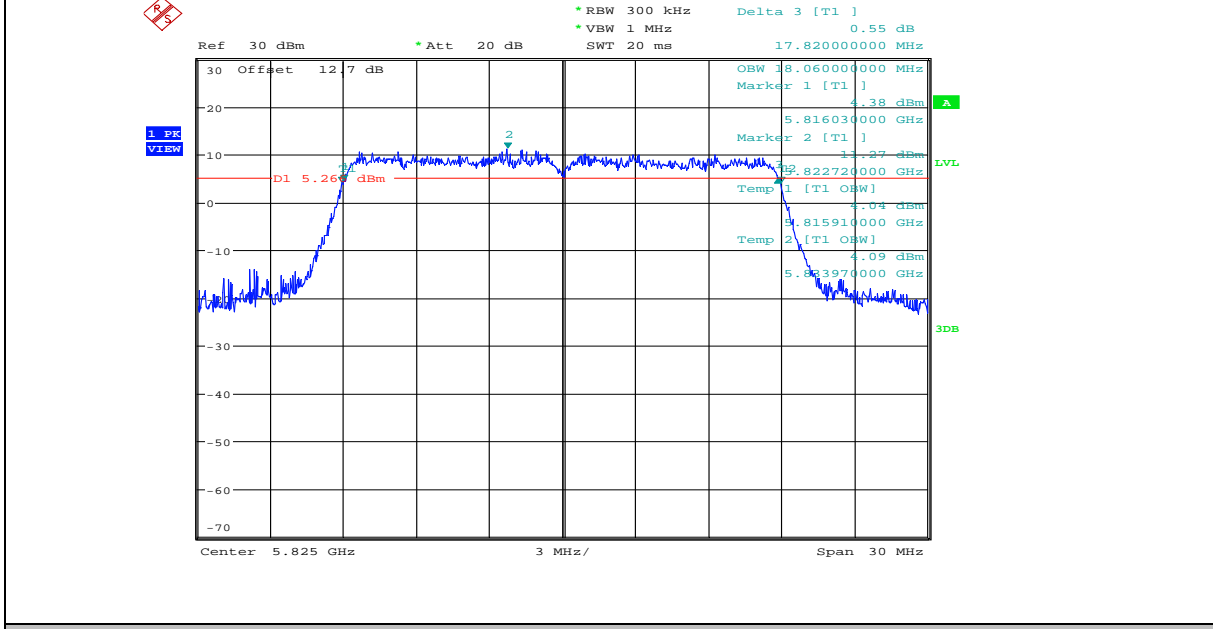

11N20MIMO\_ANT2\_5825

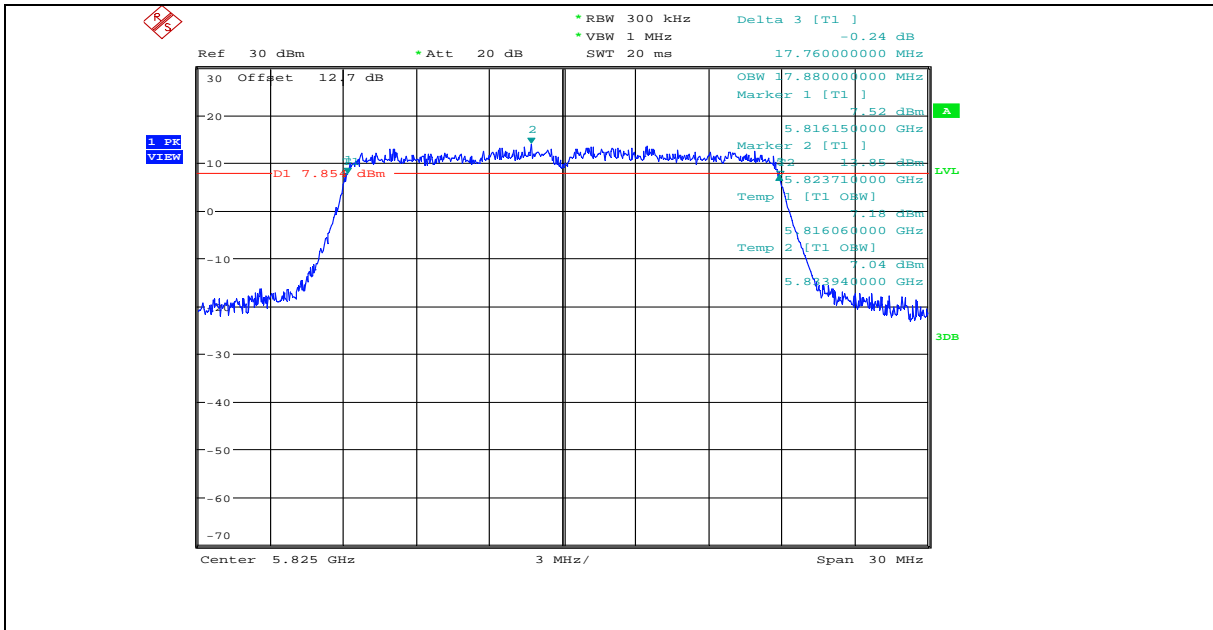

11N20MIMO\_ANT3\_5825

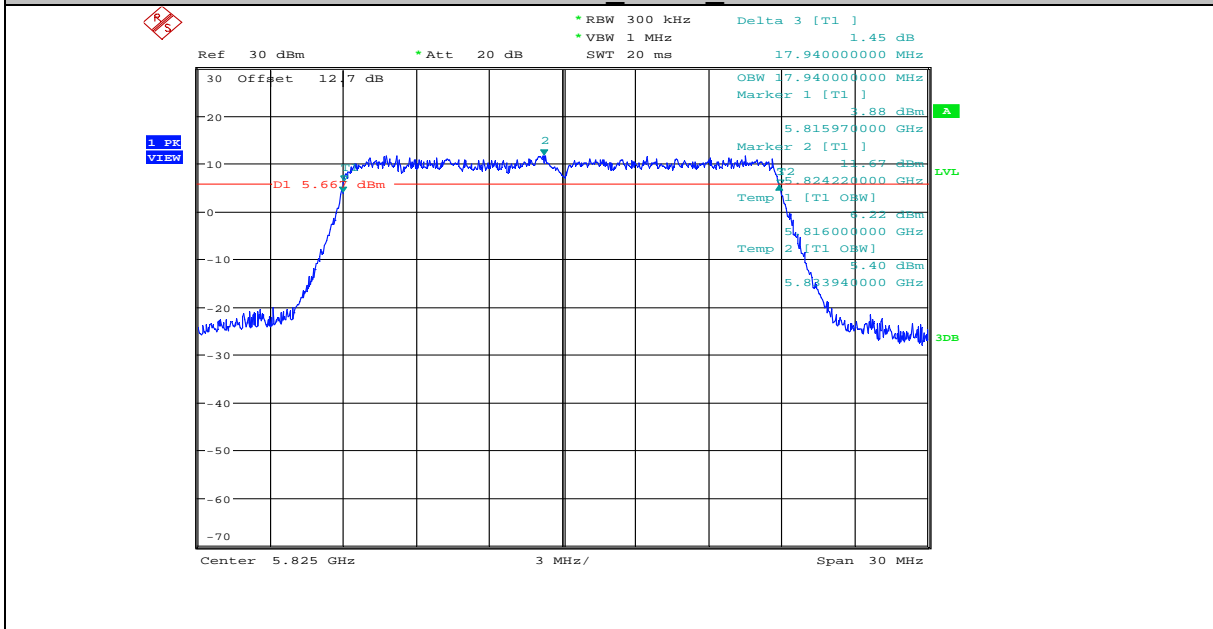

11N40MIMO\_ANT1\_5190

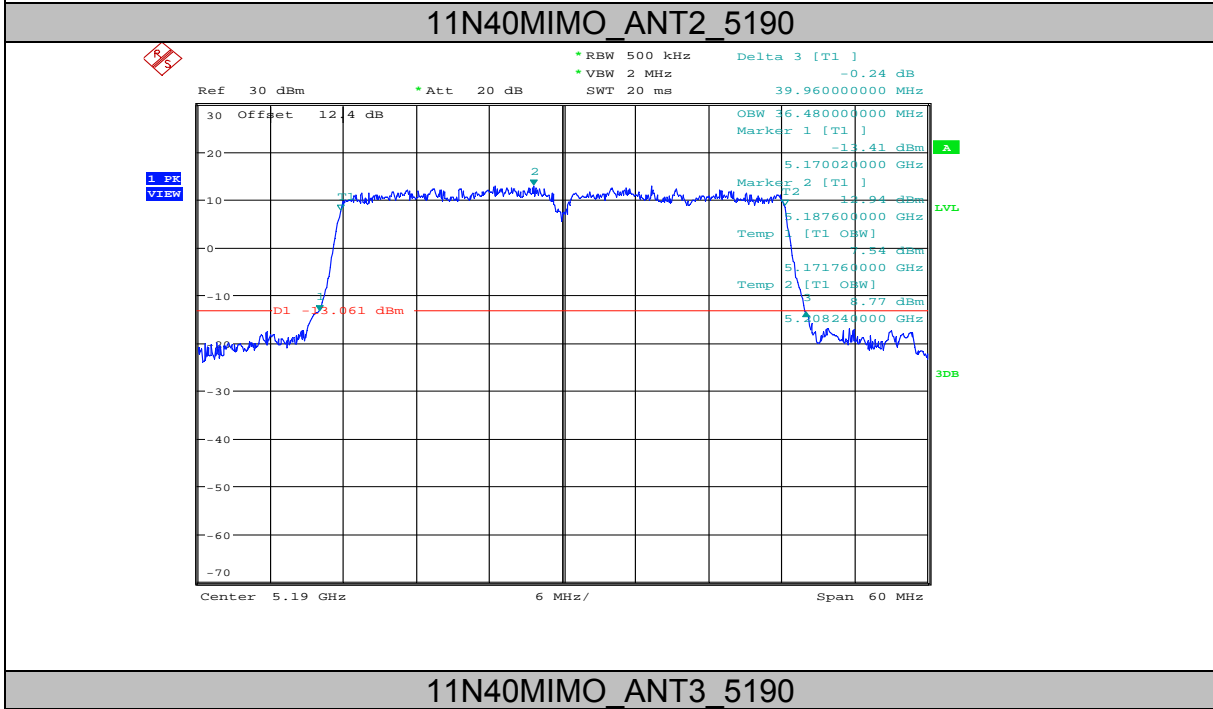
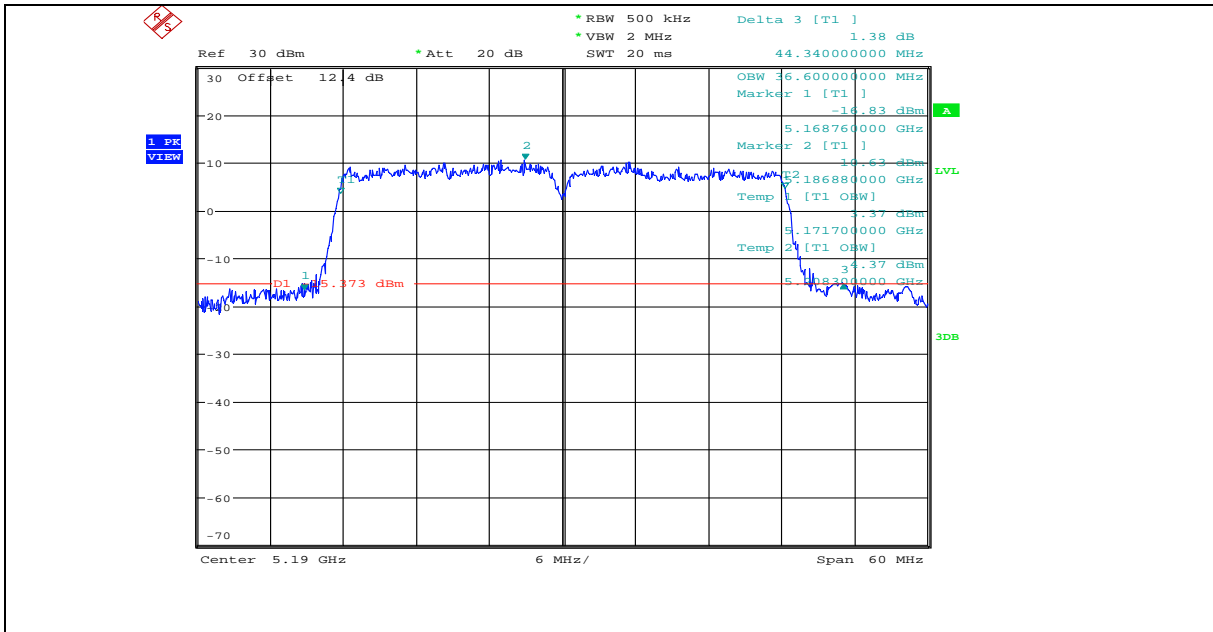

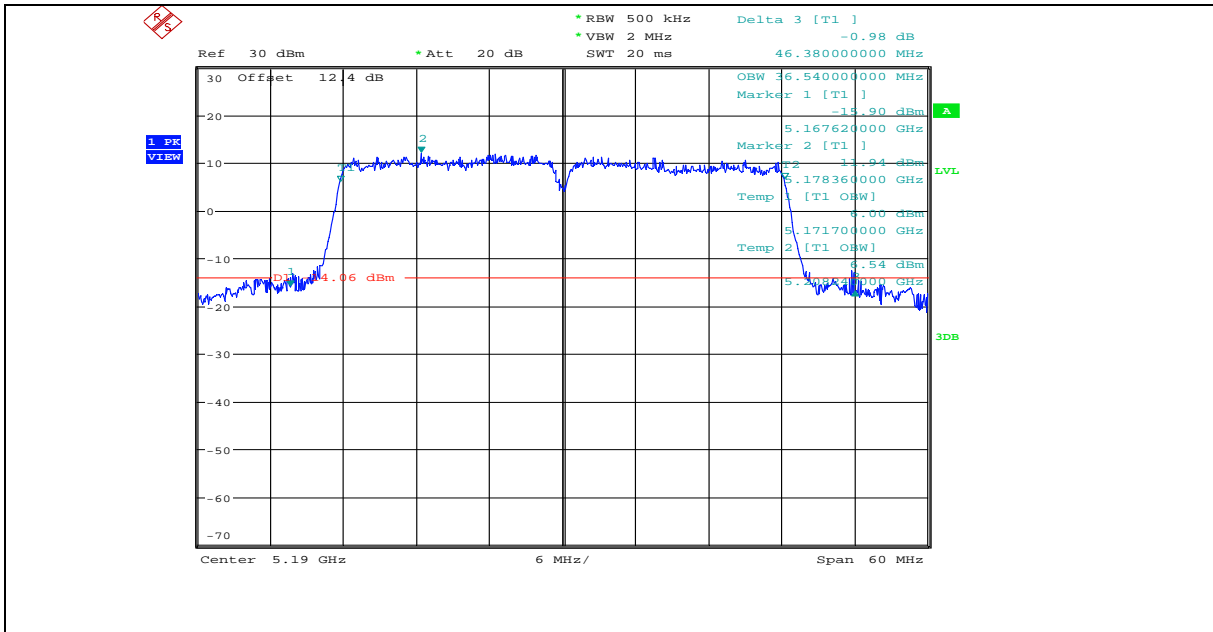

11N40MIMO ANT1 5230

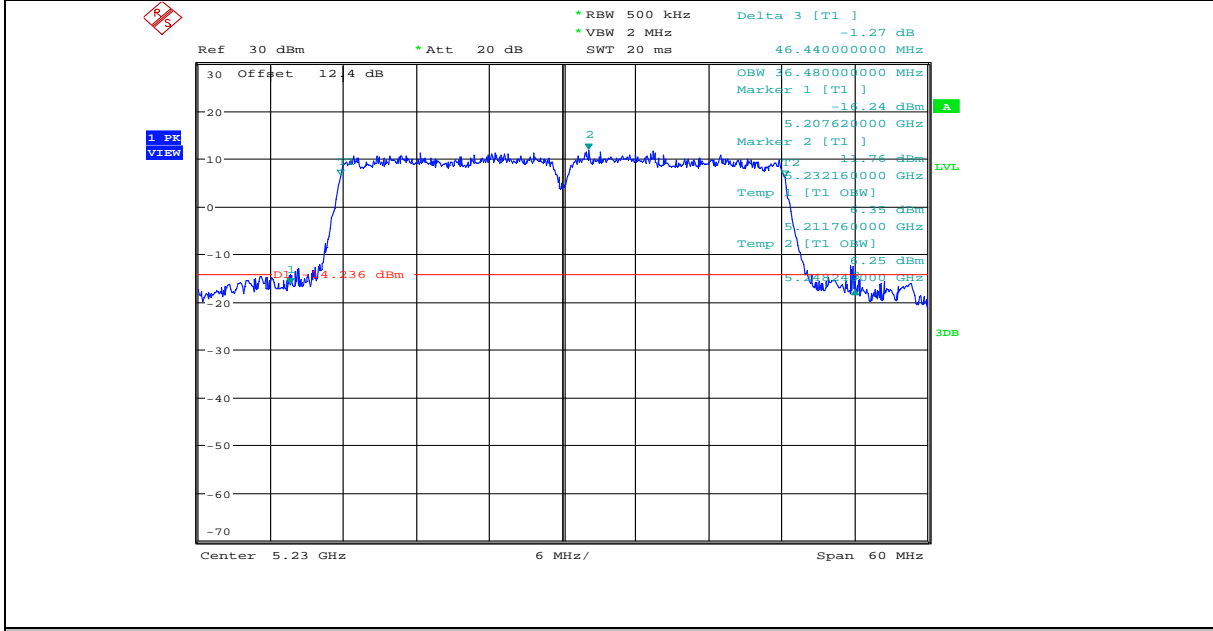

11N40MIMO ANT2 5230



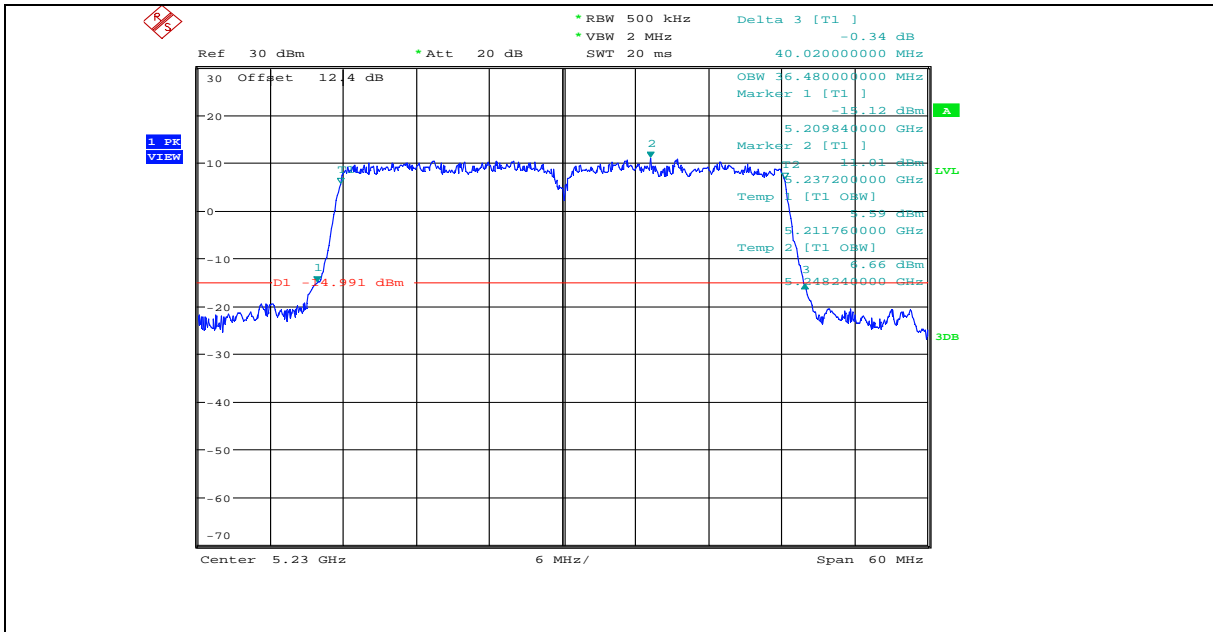

11N40MIMO\_ANT3\_5230

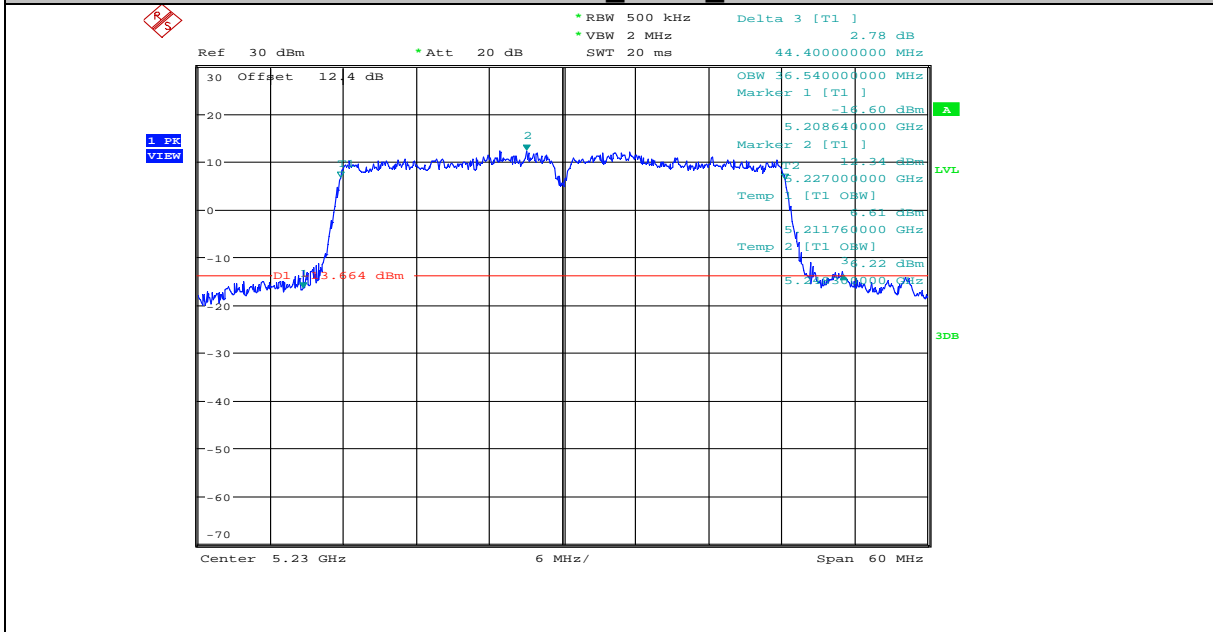

11N40MIMO\_ANT1\_5755

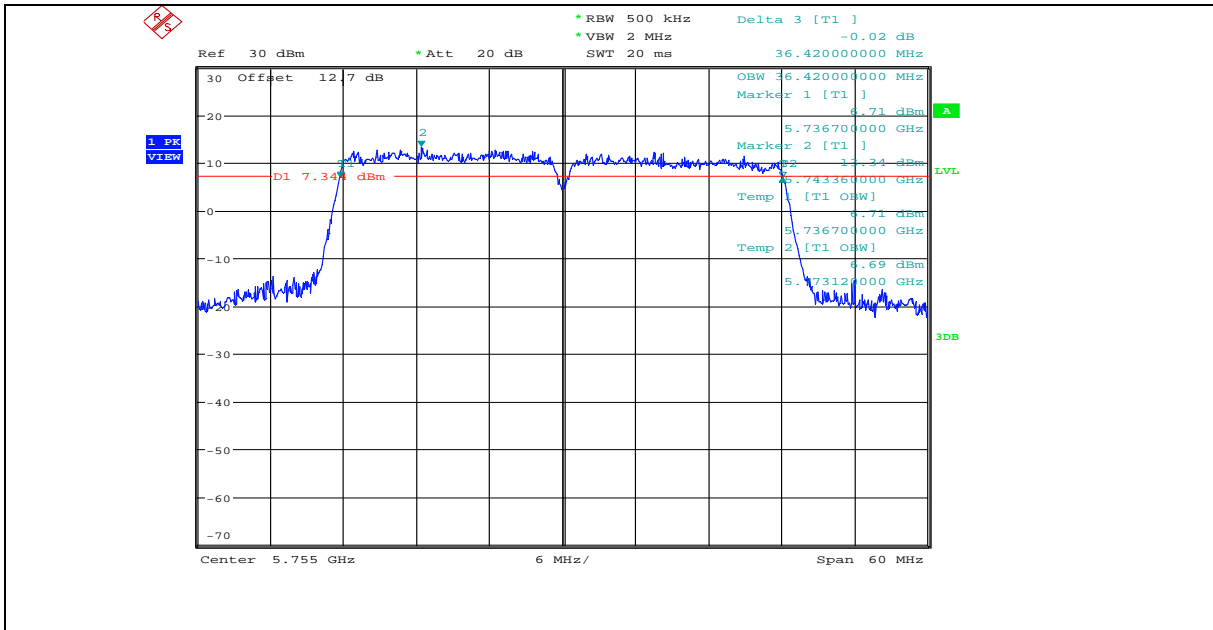

11N40MIMO\_ANT2\_5755

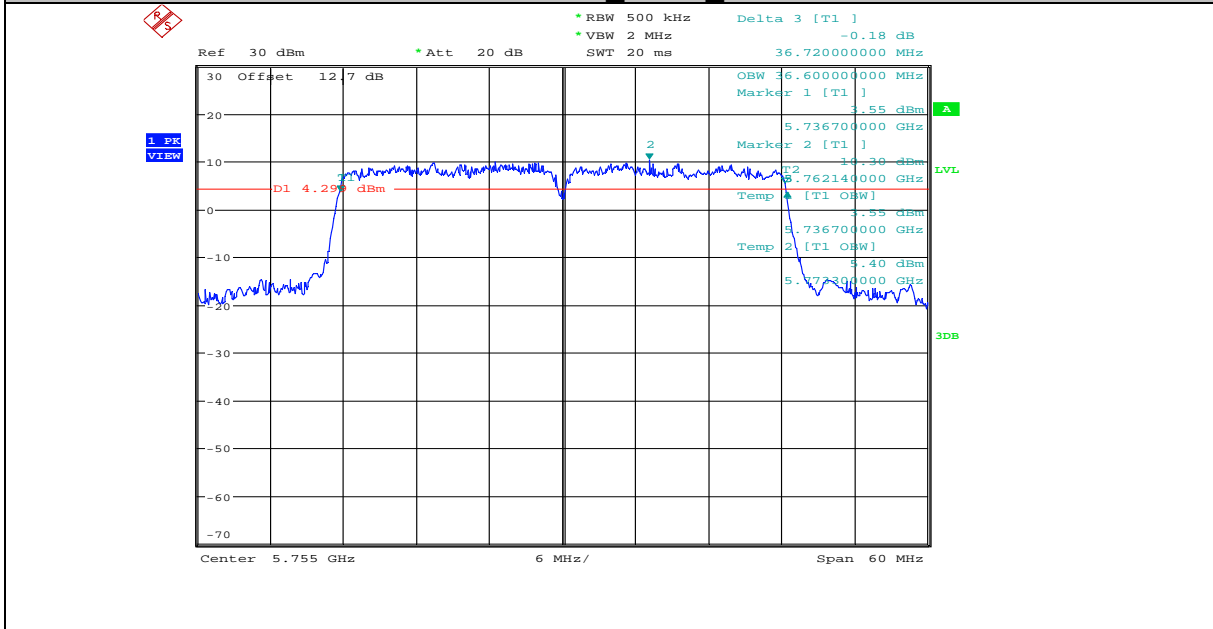

11N40MIMO\_ANT3\_5755

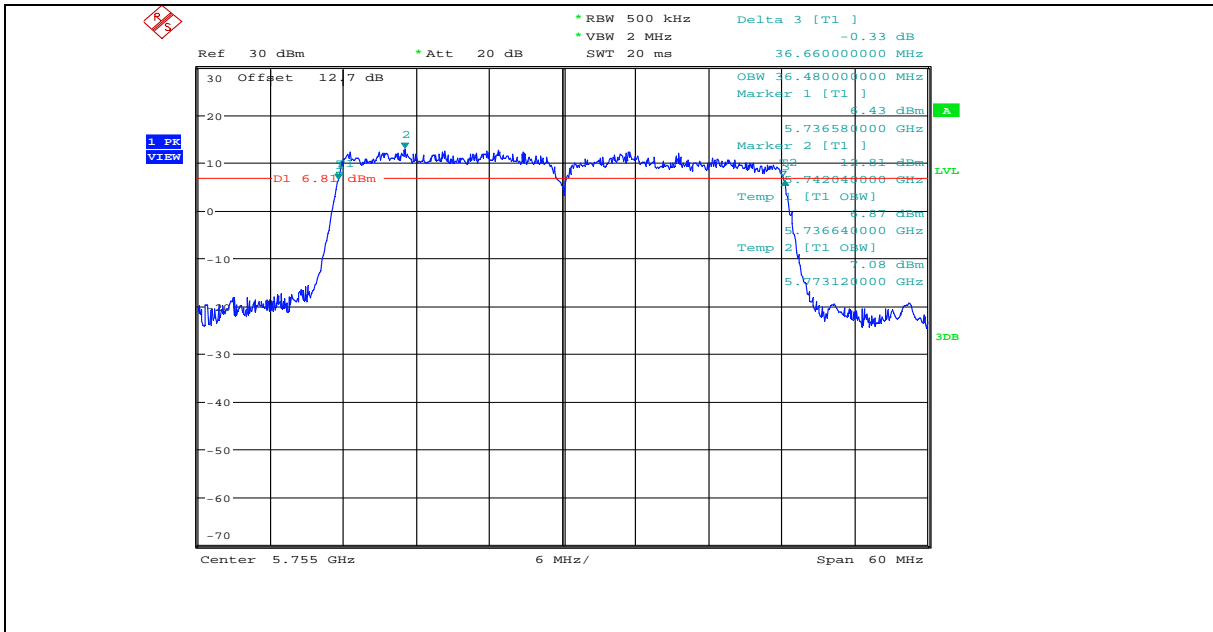

11N40MIMO\_ANT1\_5795

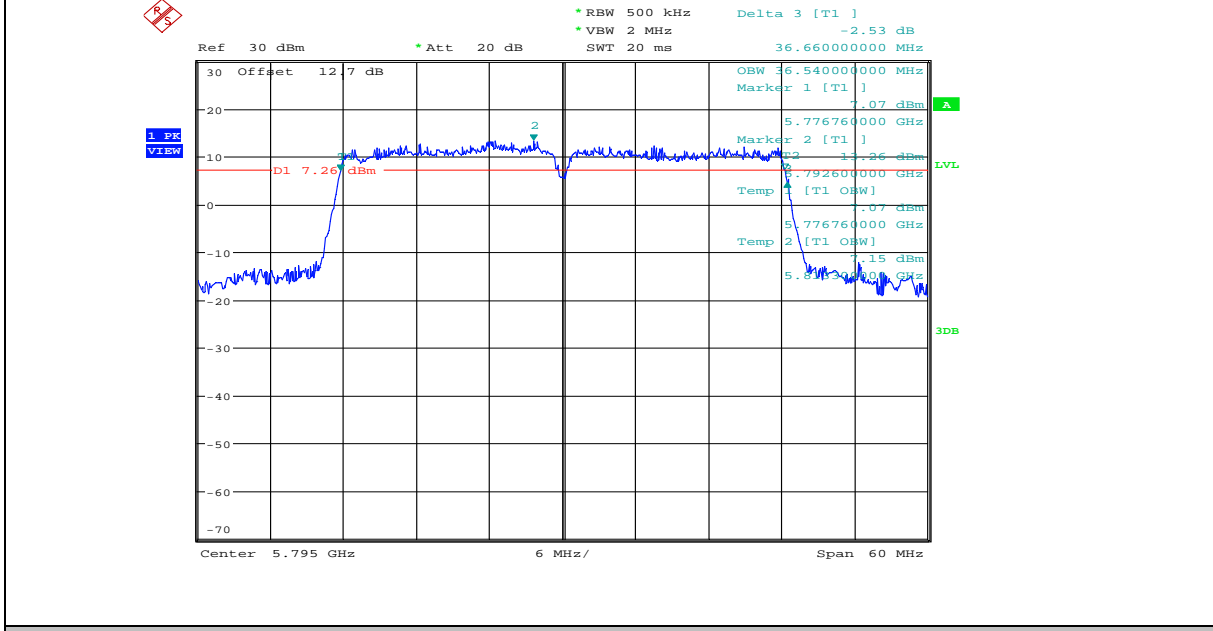

11N40MIMO\_ANT2\_5795

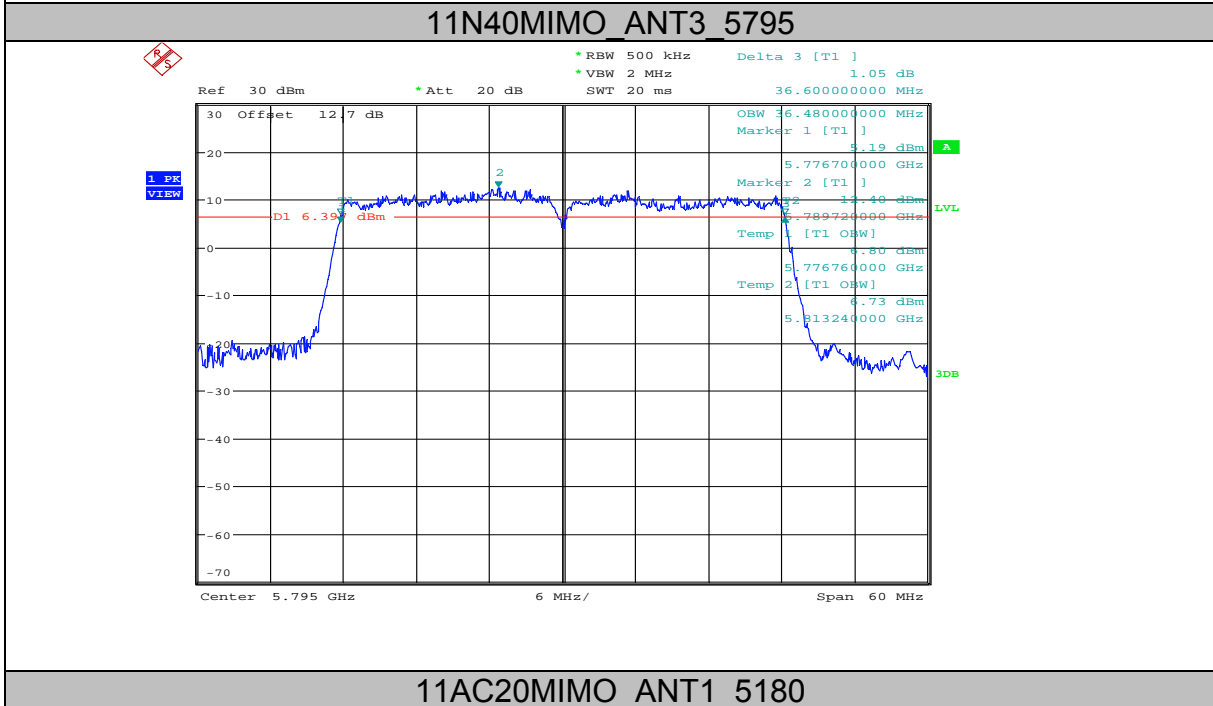
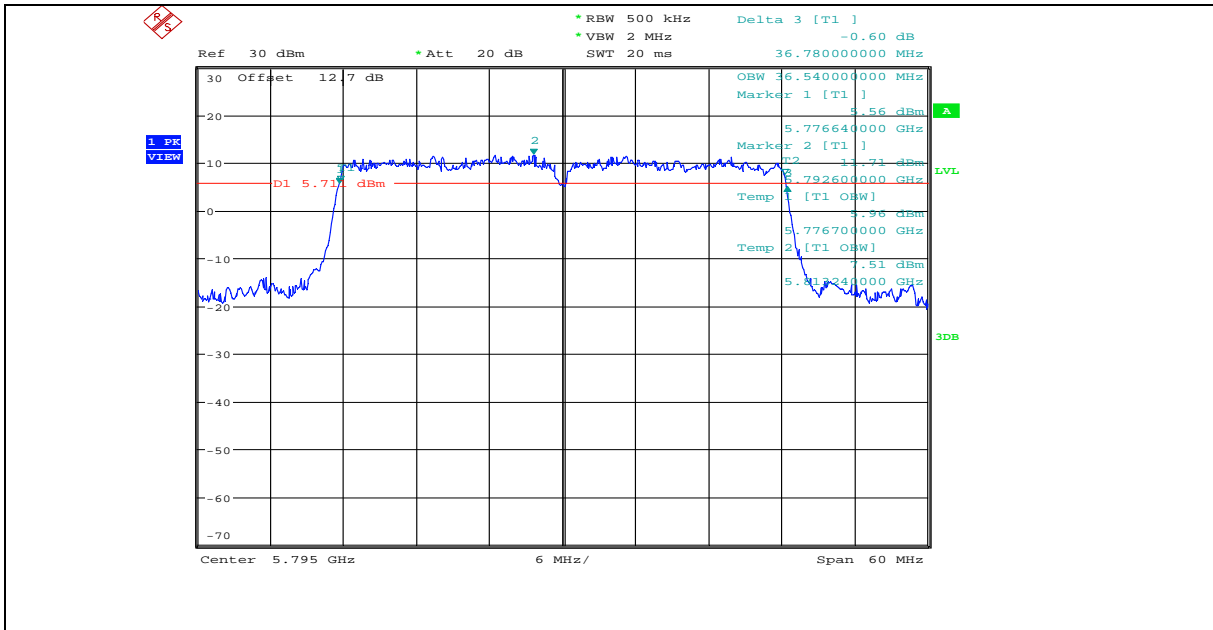

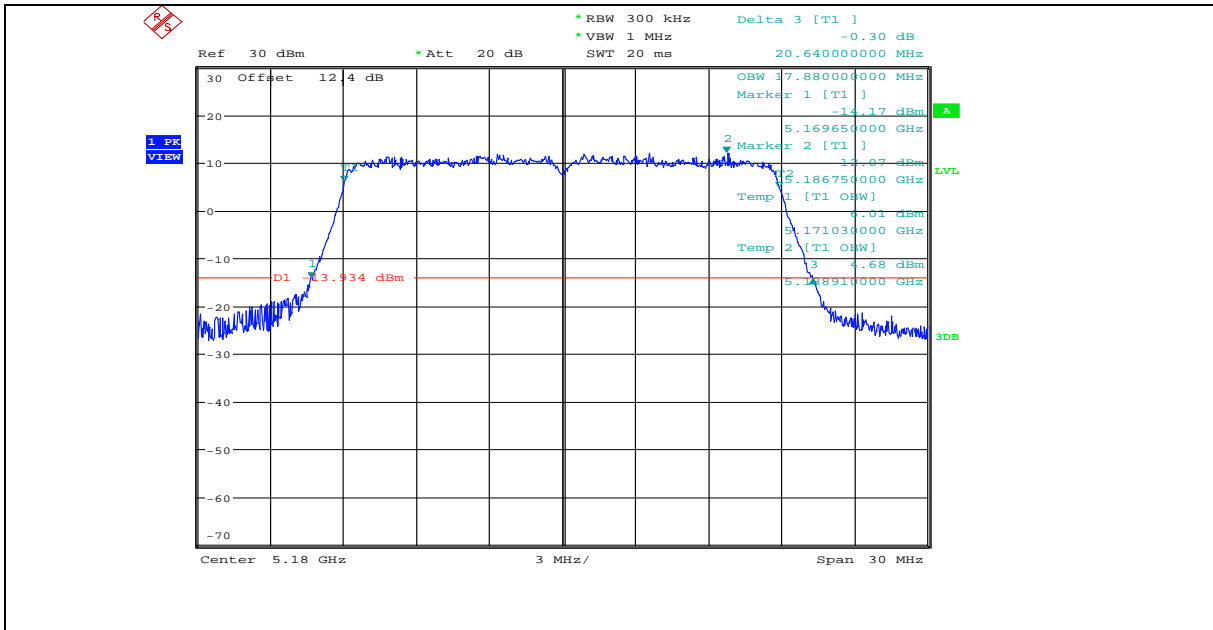

11AC20MIMO ANT2 5180

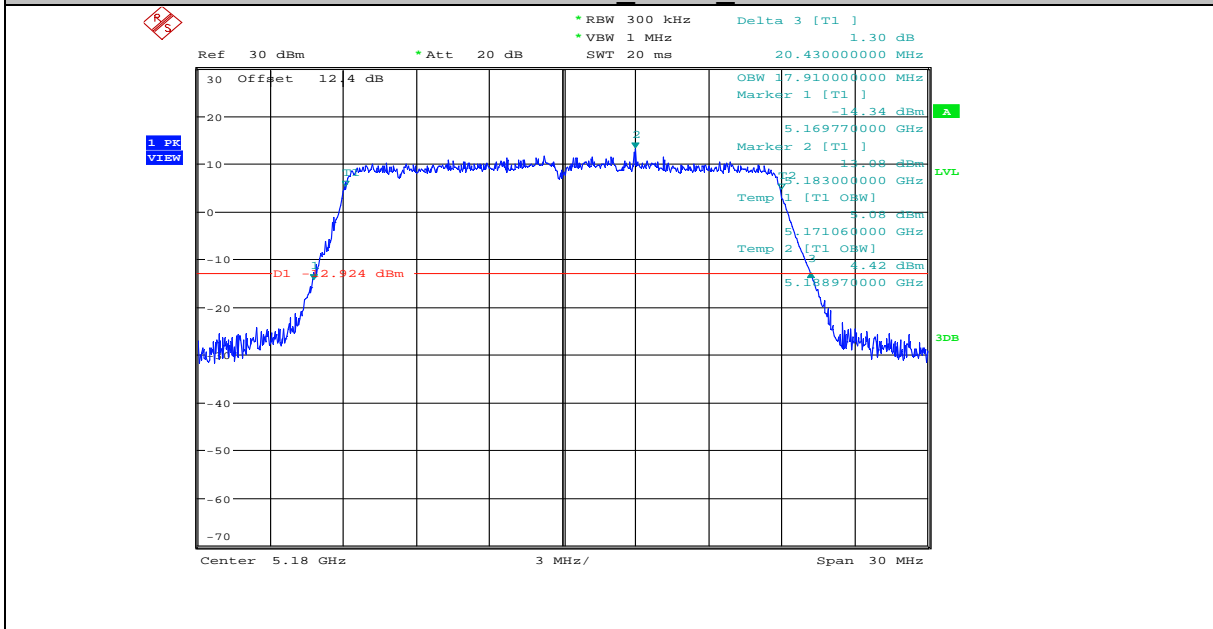

11AC20MIMO ANT3 5180

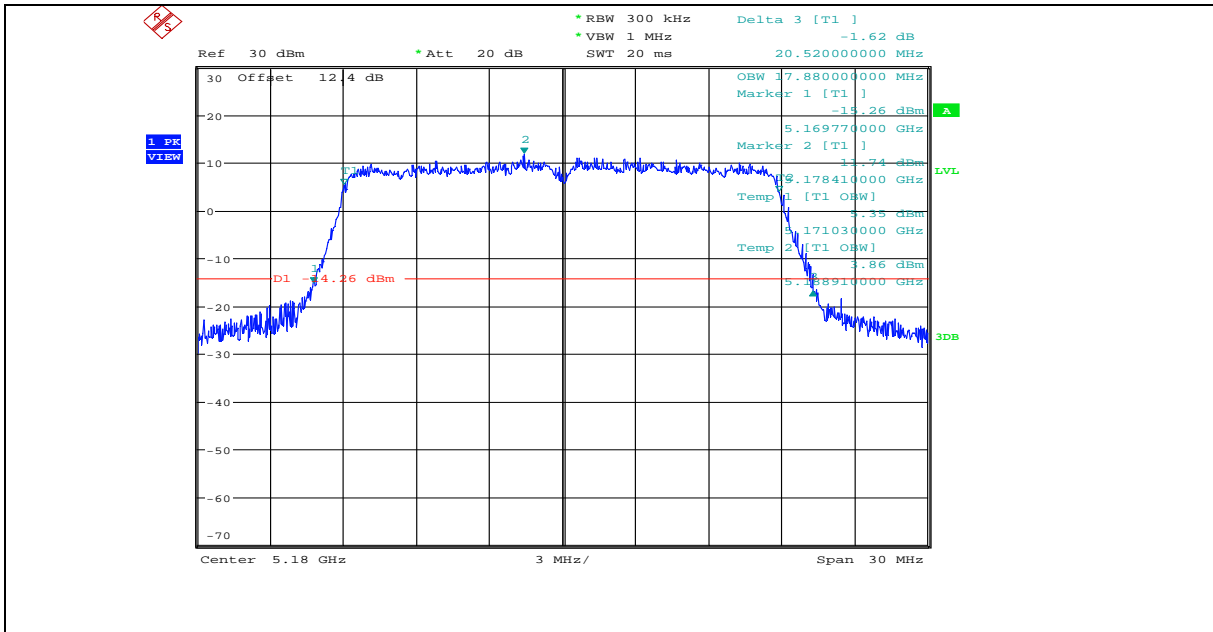

11AC20MIMO\_ANT1\_5200

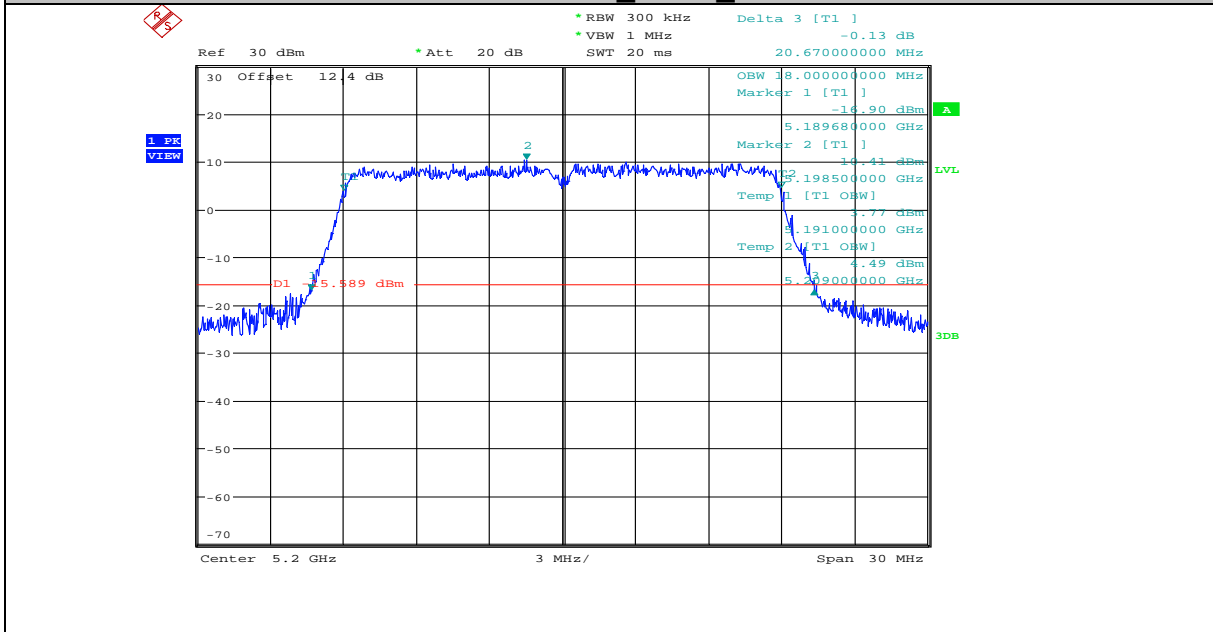

11AC20MIMO\_ANT2\_5200

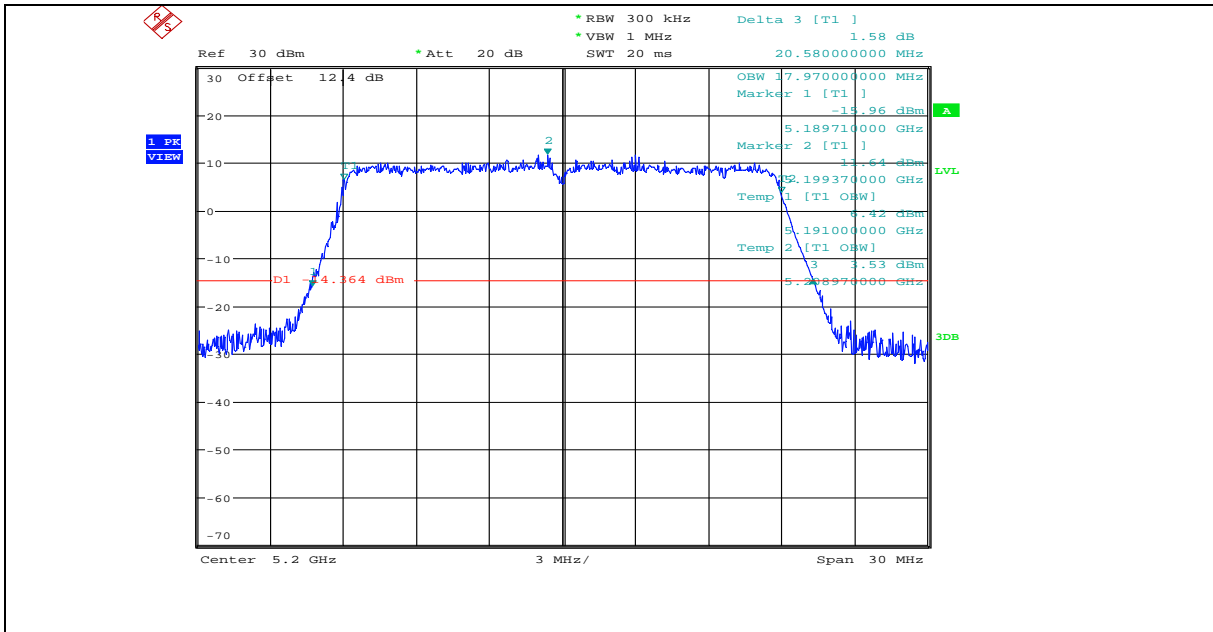

11AC20MIMO\_ANT3\_5200

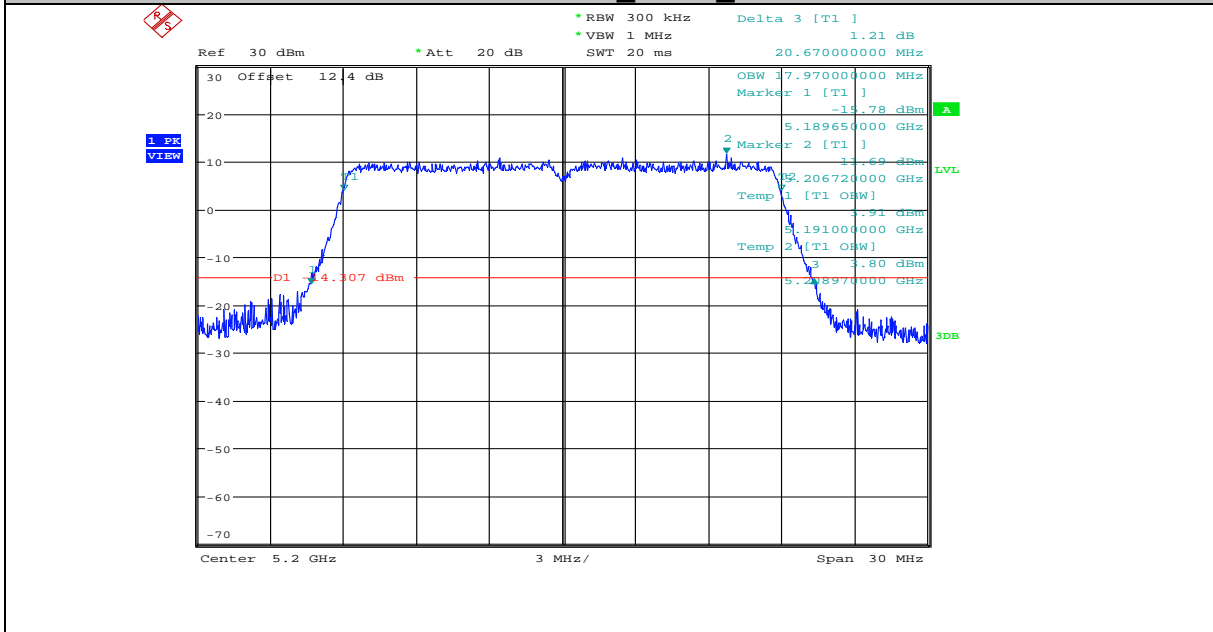

11AC20MIMO\_ANT1\_5240

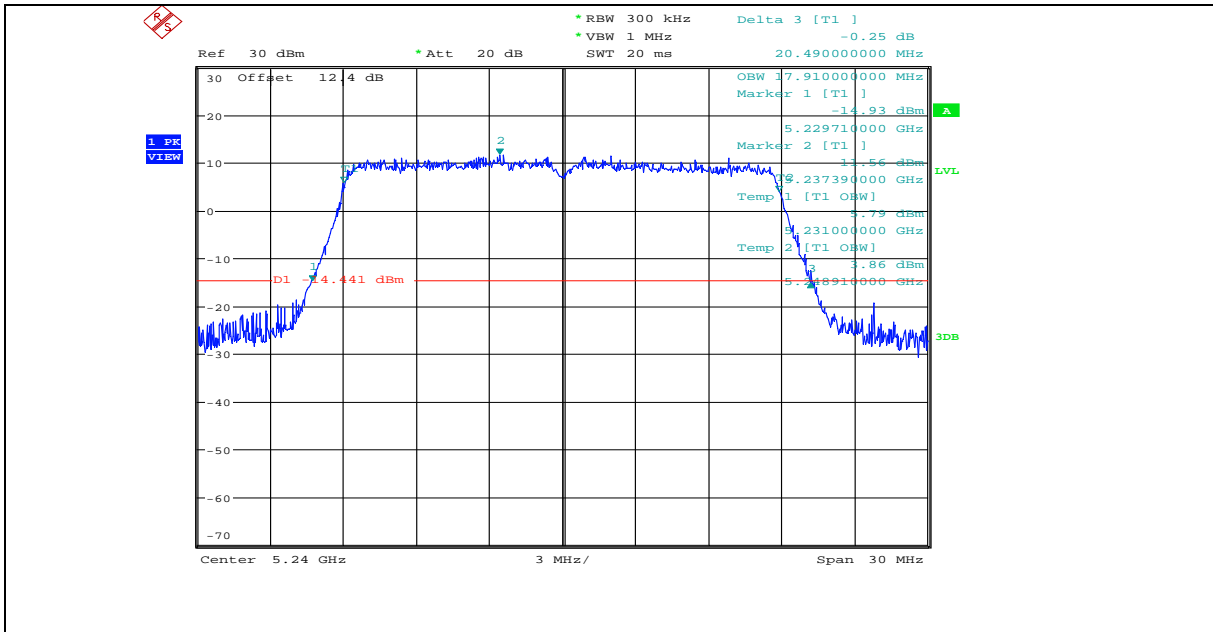

11AC20MIMO\_ANT2\_5240

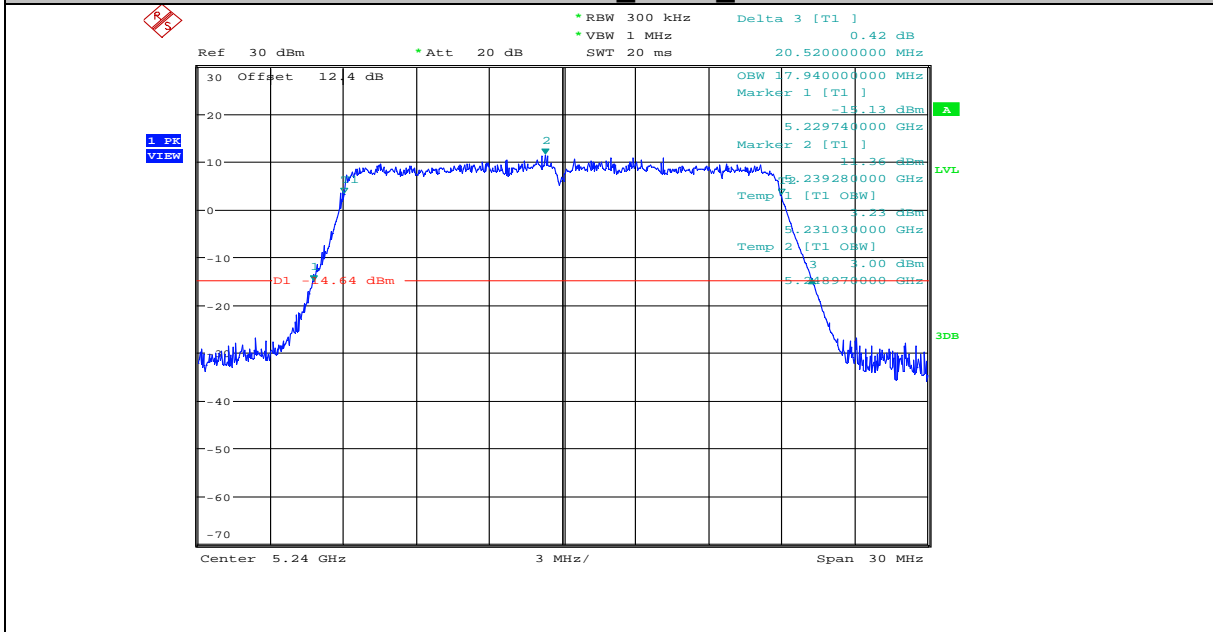

11AC20MIMO\_ANT3\_5240



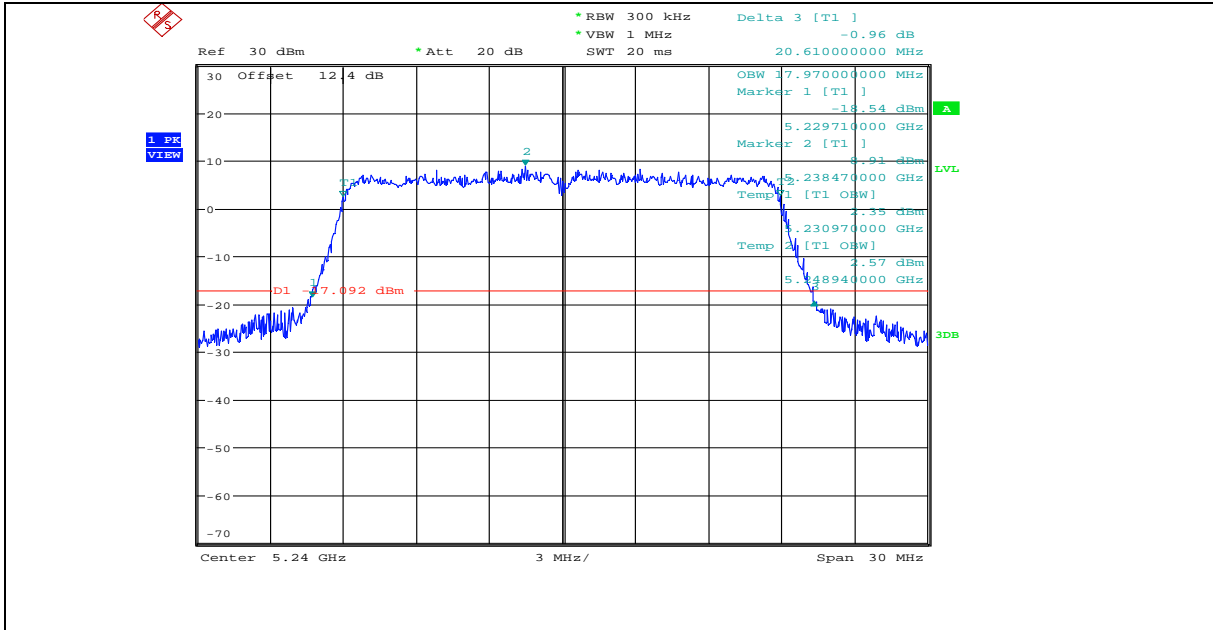

11AC20MIMO\_ANT1\_5745

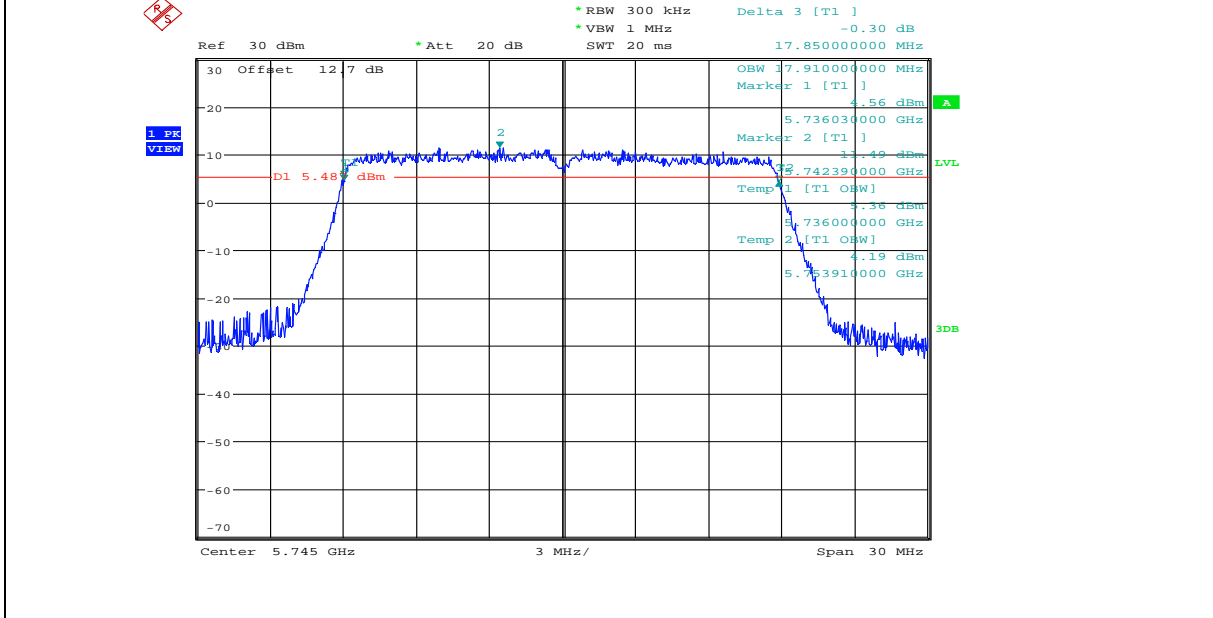

11AC20MIMO\_ANT2\_5745

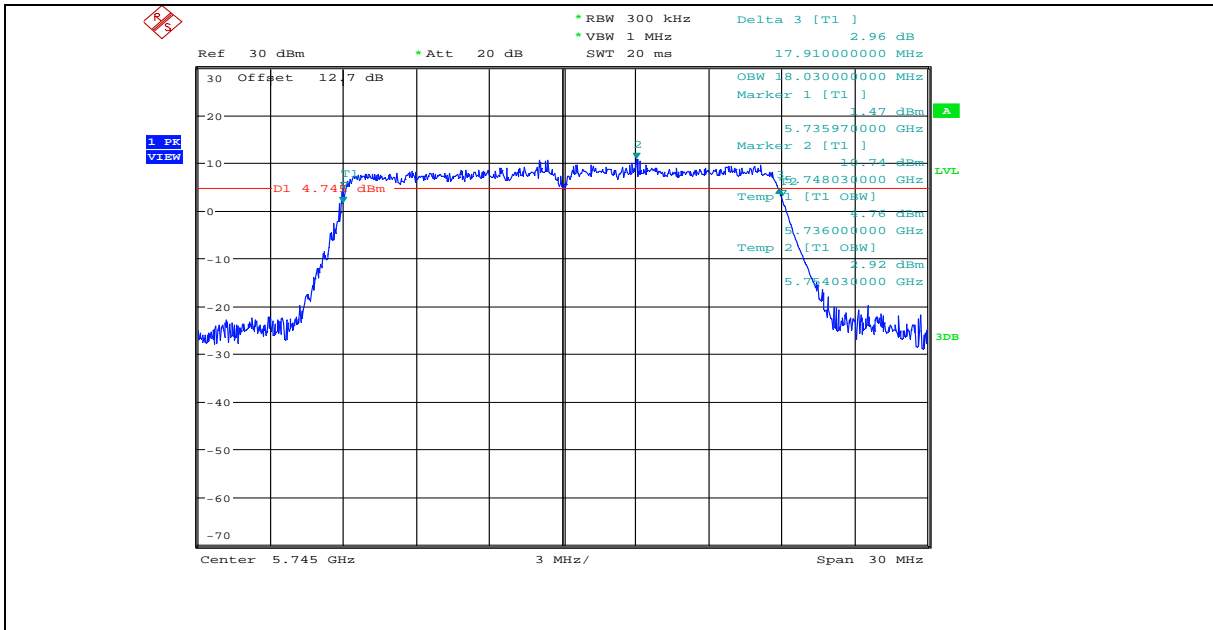

11AC20MIMO ANT3 5745

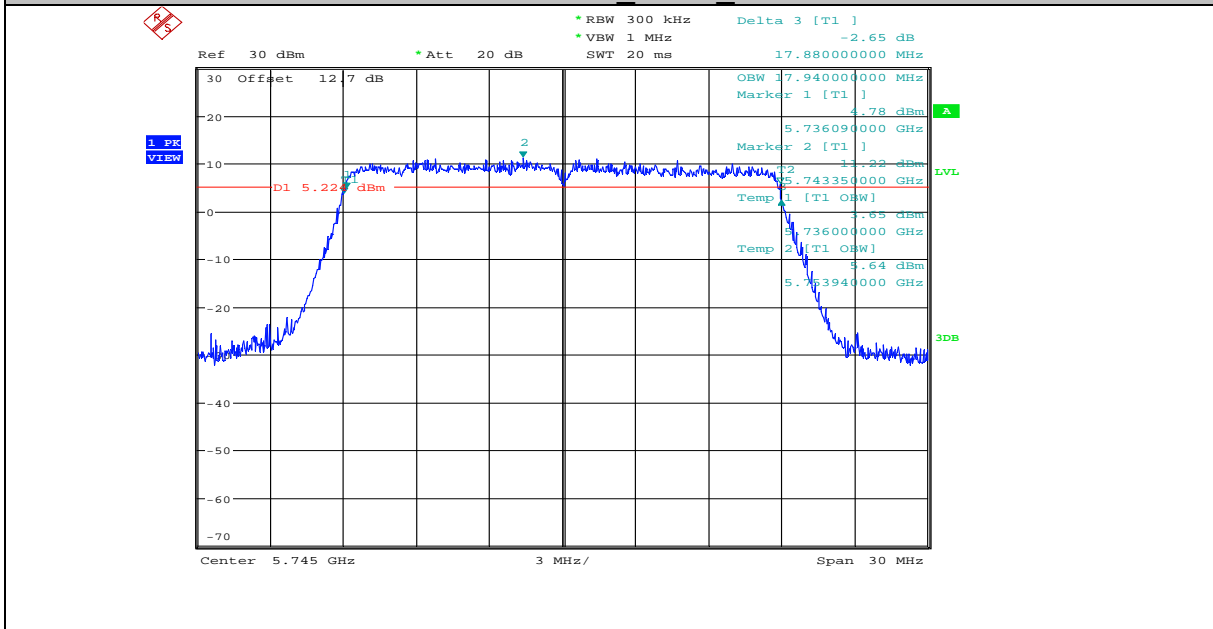

11AC20MIMO ANT1 5785

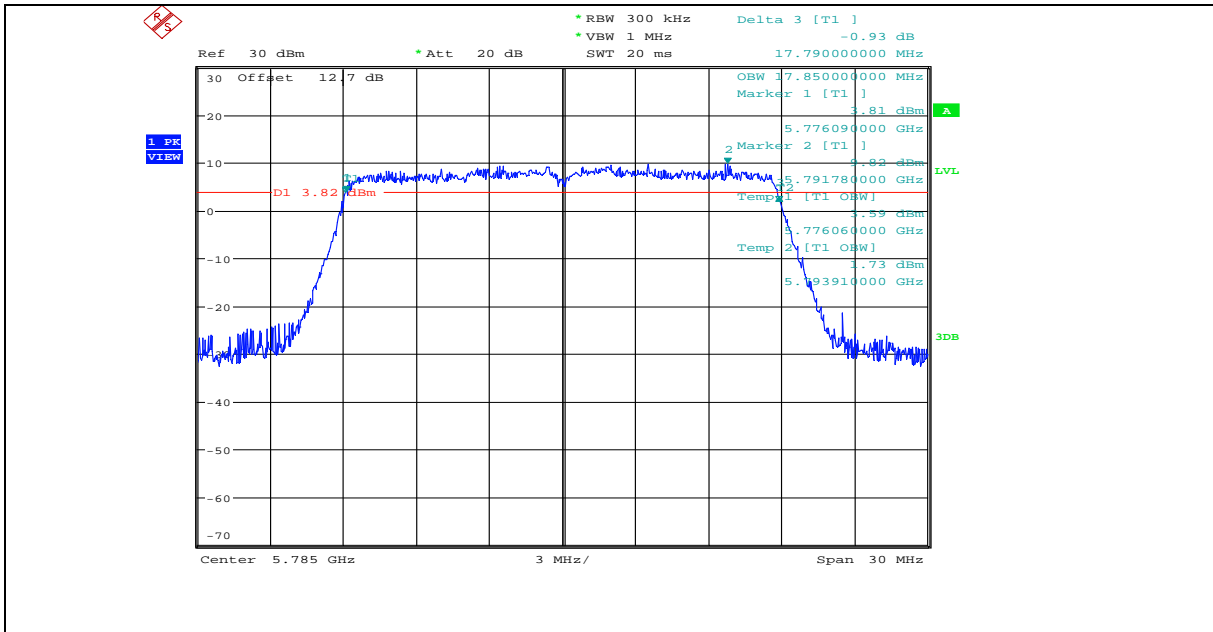

11AC20MIMO\_ANT2\_5785

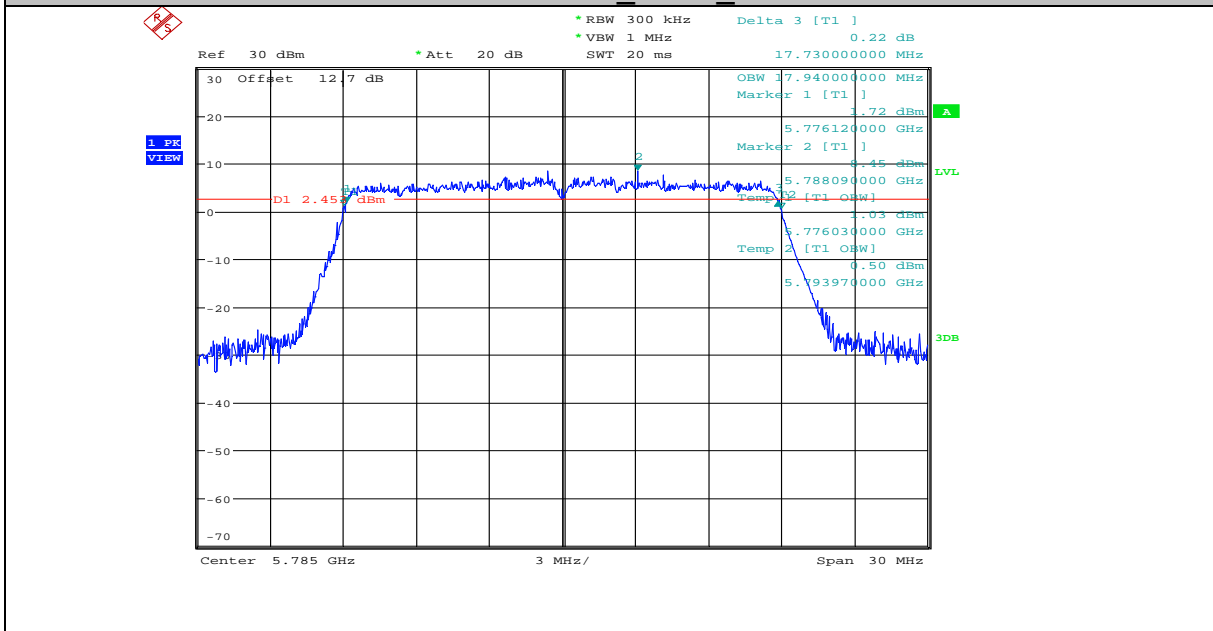

11AC20MIMO\_ANT3\_5785

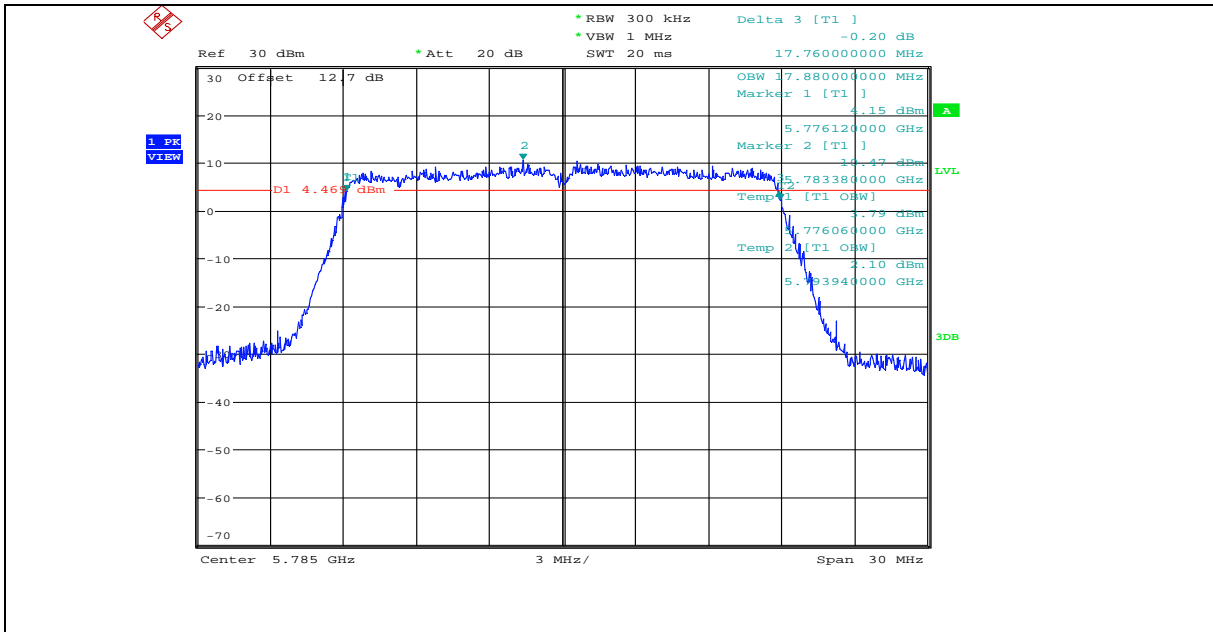

11AC20MIMO\_ANT1\_5825

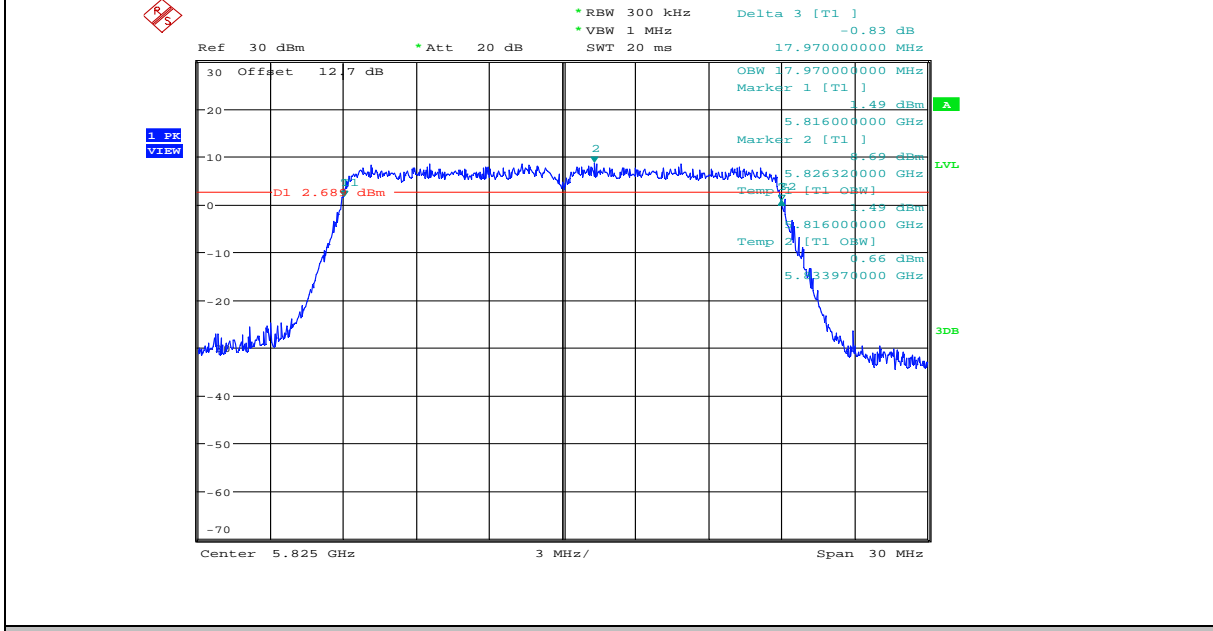

11AC20MIMO\_ANT2\_5825

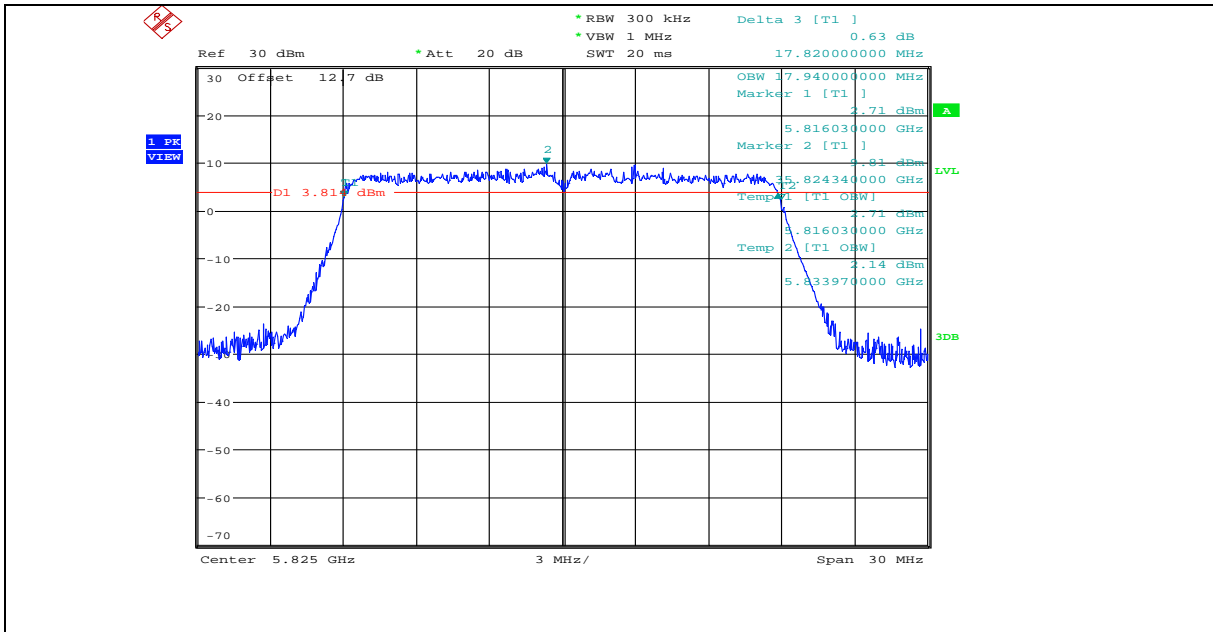

11AC20MIMO\_ANT3\_5825

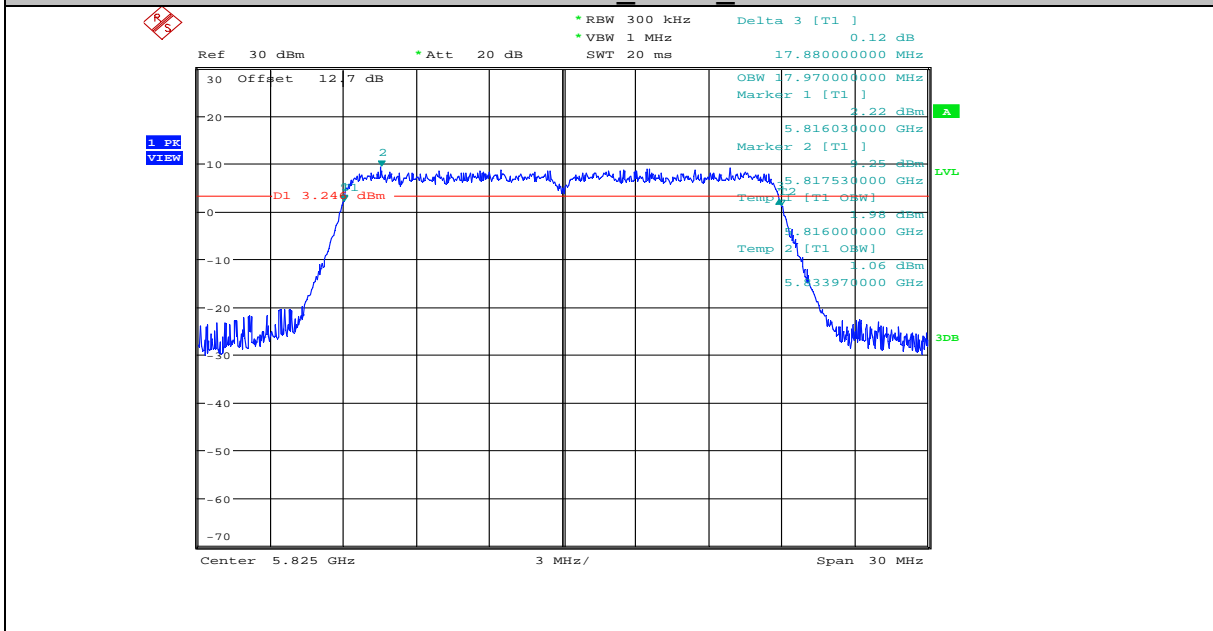

11AC40MIMO\_ANT1\_5190

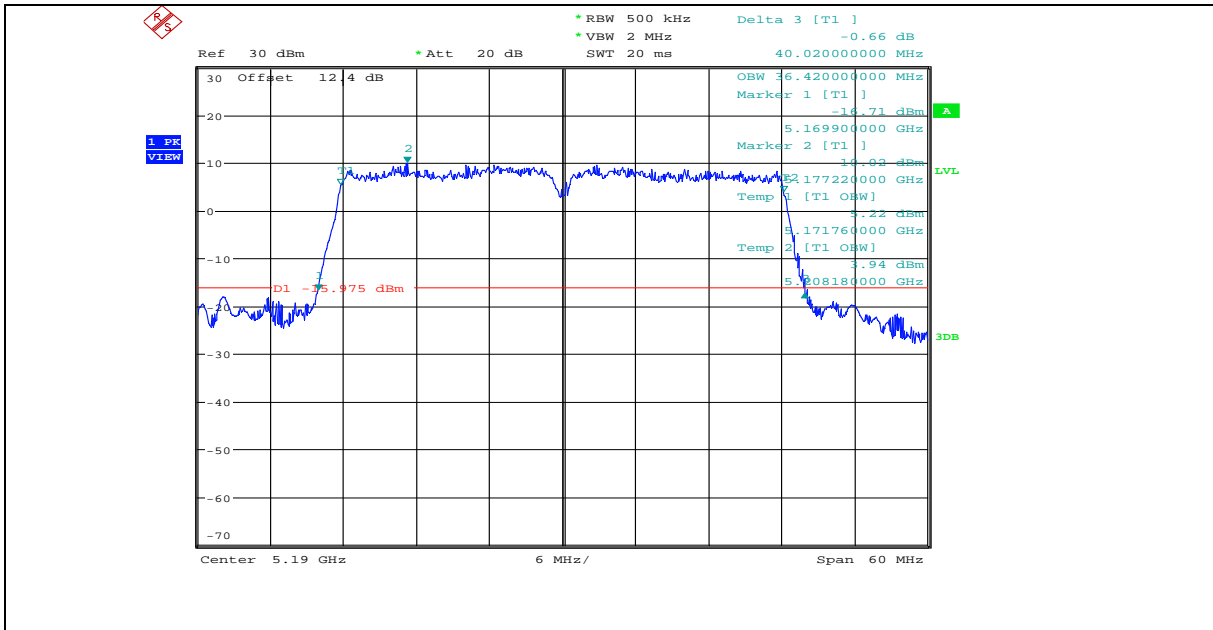

11AC40MIMO ANT2 5190

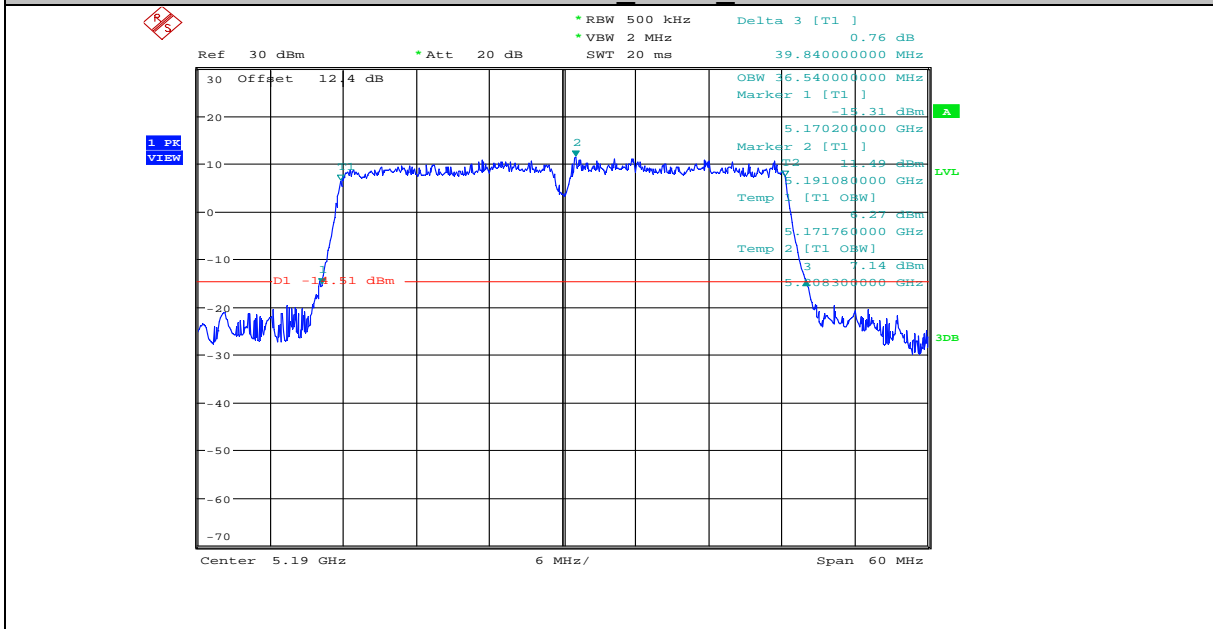

11AC40MIMO ANT3 5190

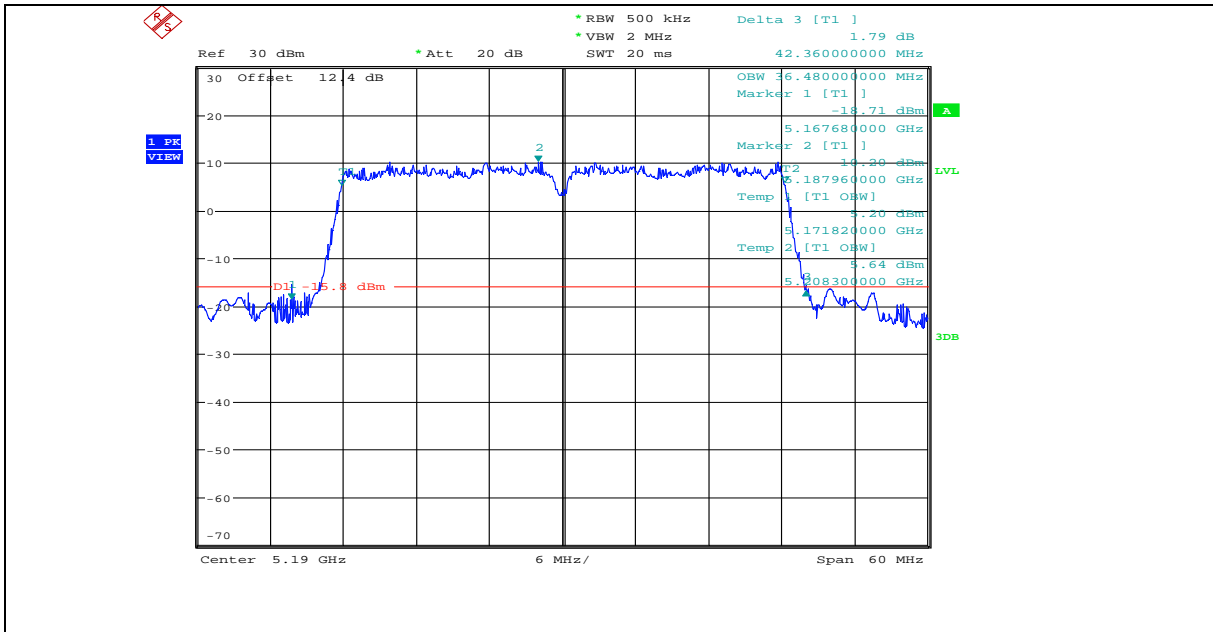

11AC40MIMO\_ANT1\_5230

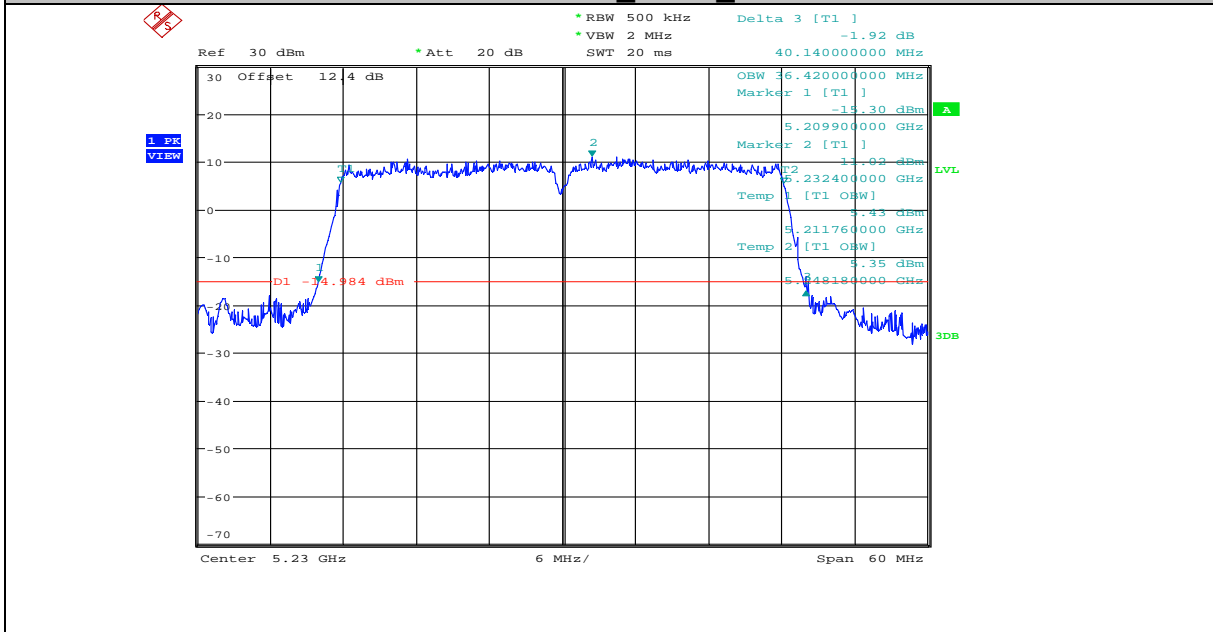

11AC40MIMO\_ANT2\_5230

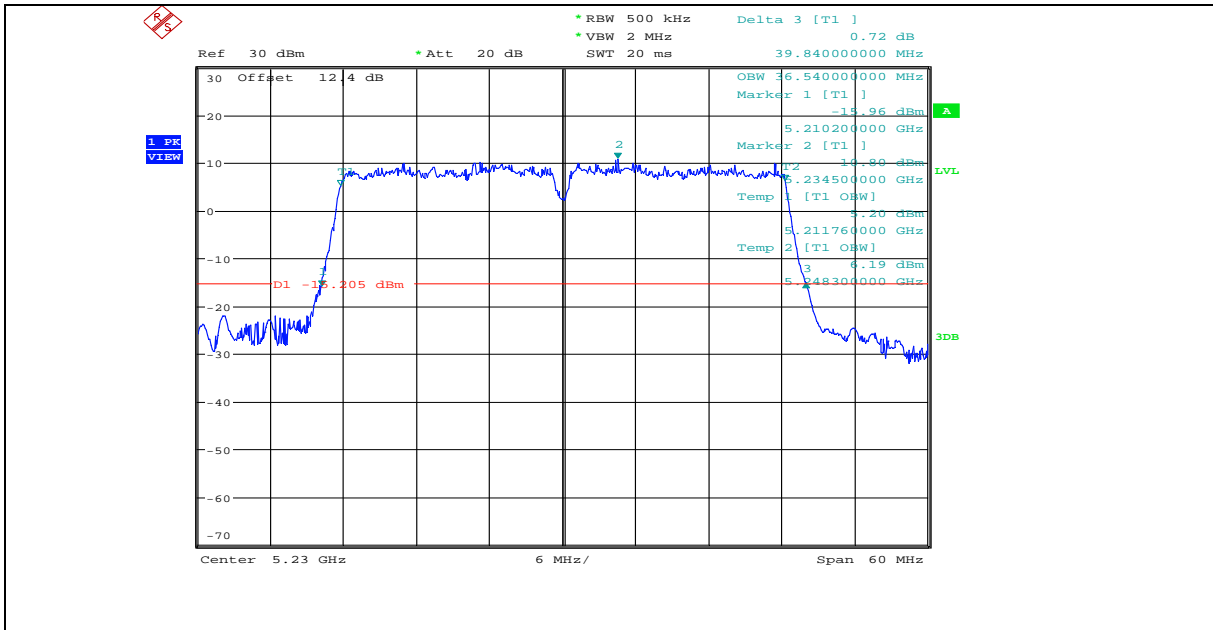

11AC40MIMO ANT3 5230

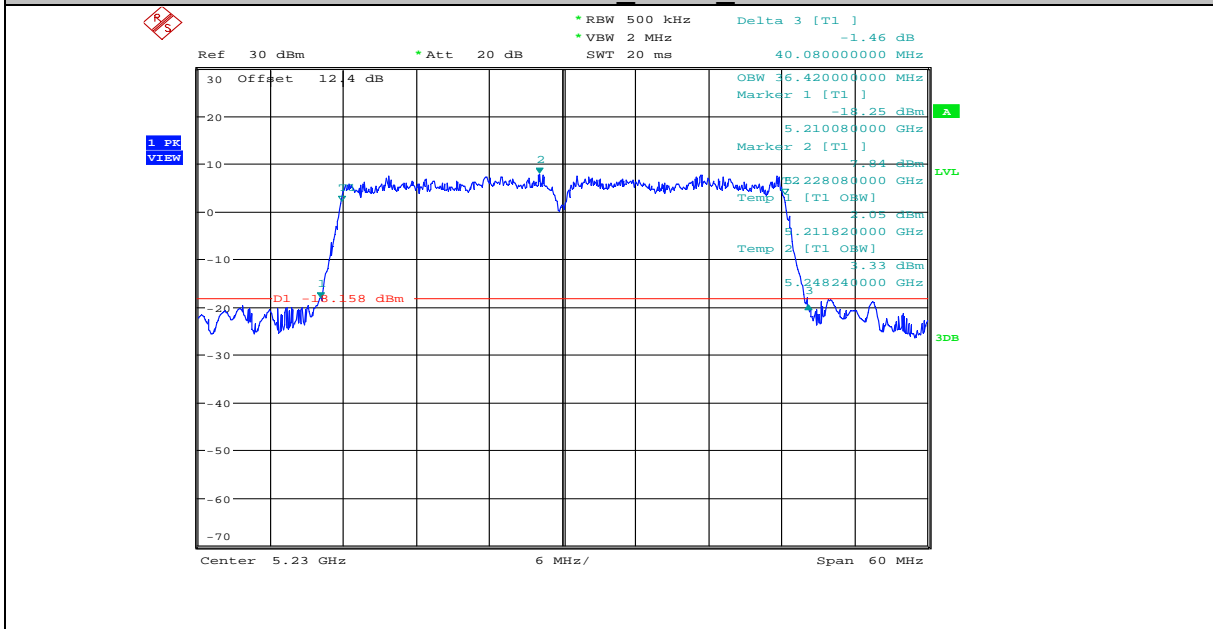

11AC40MIMO ANT1 5755



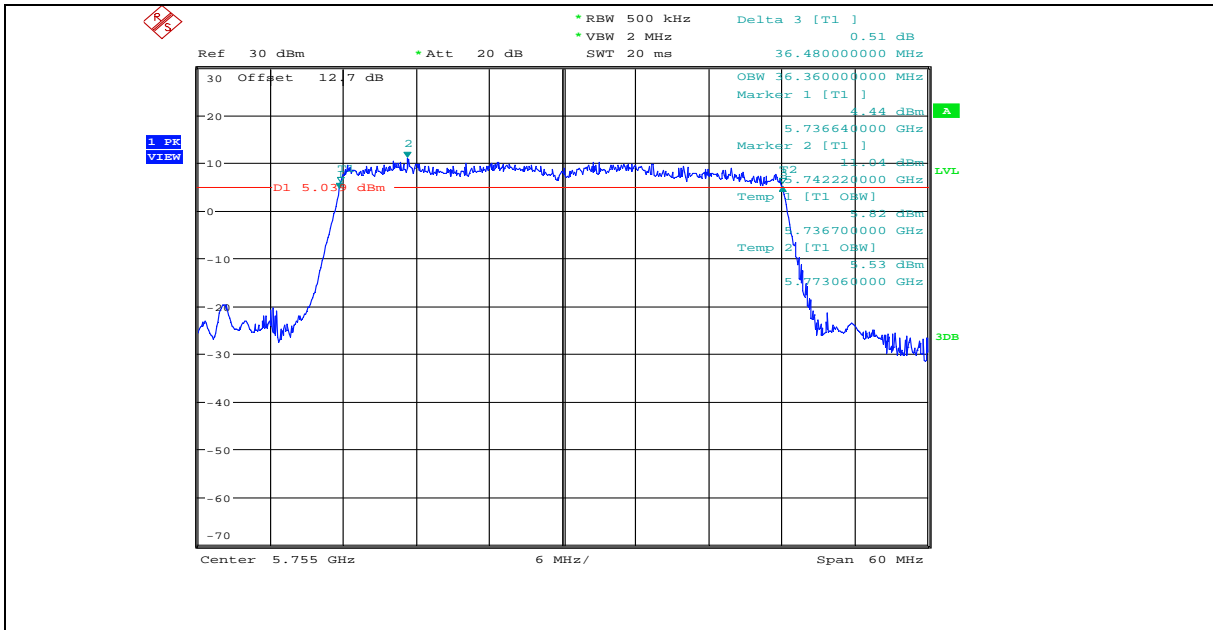

11AC40MIMO ANT2 5755

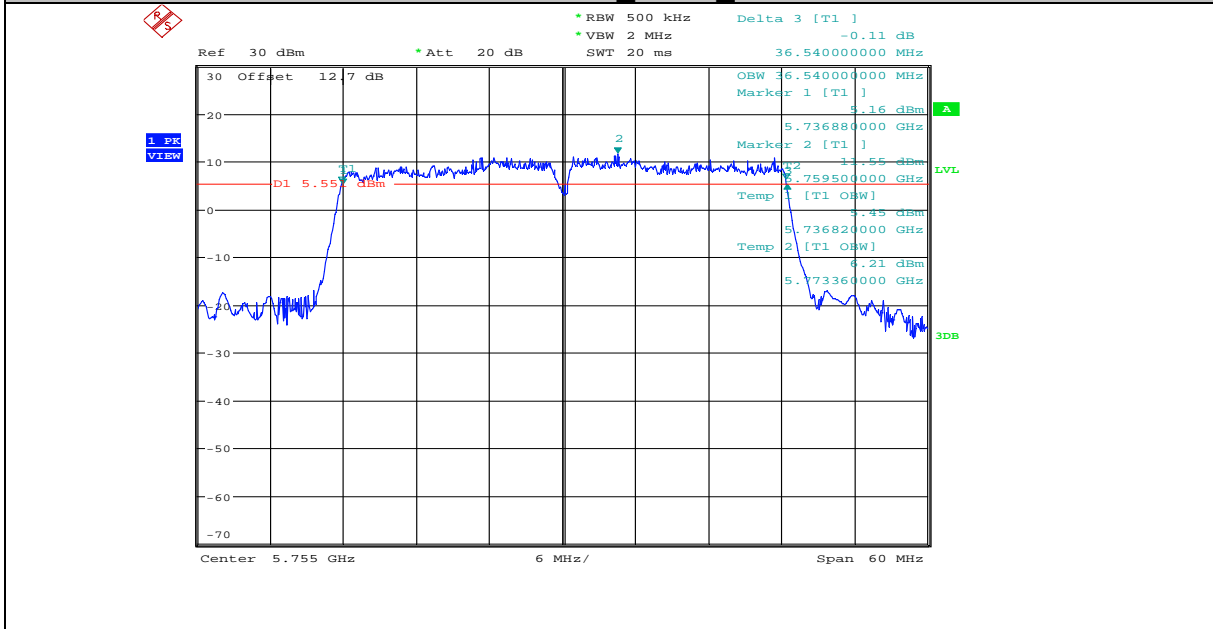

11AC40MIMO ANT3 5755

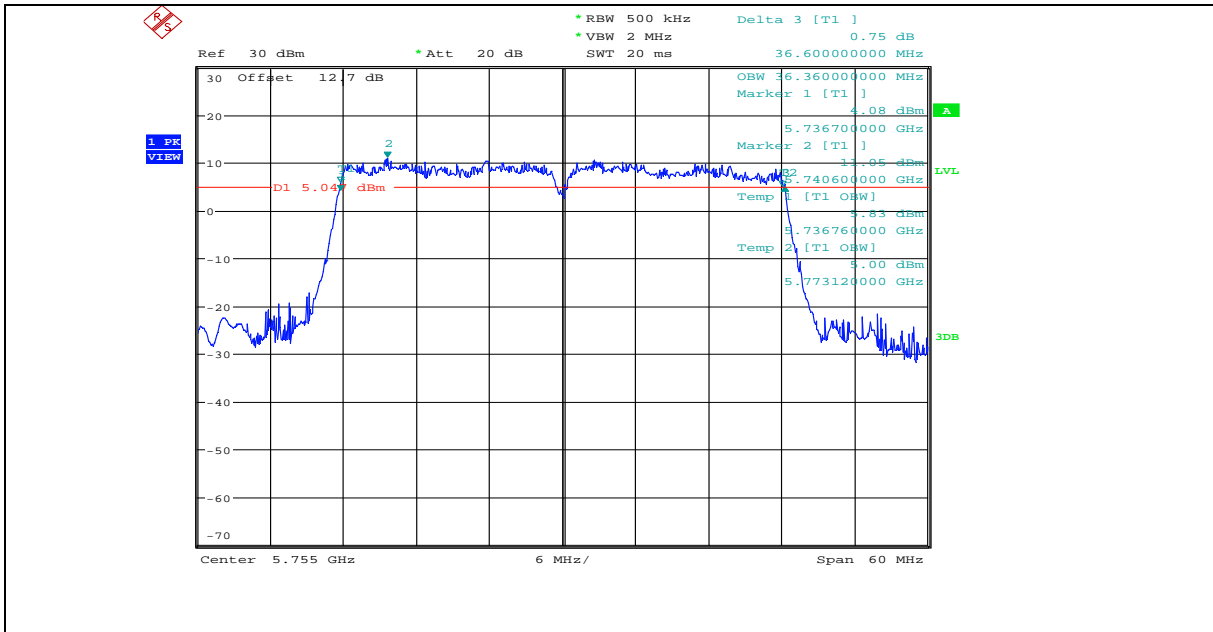

11AC40MIMO\_ANT1\_5795

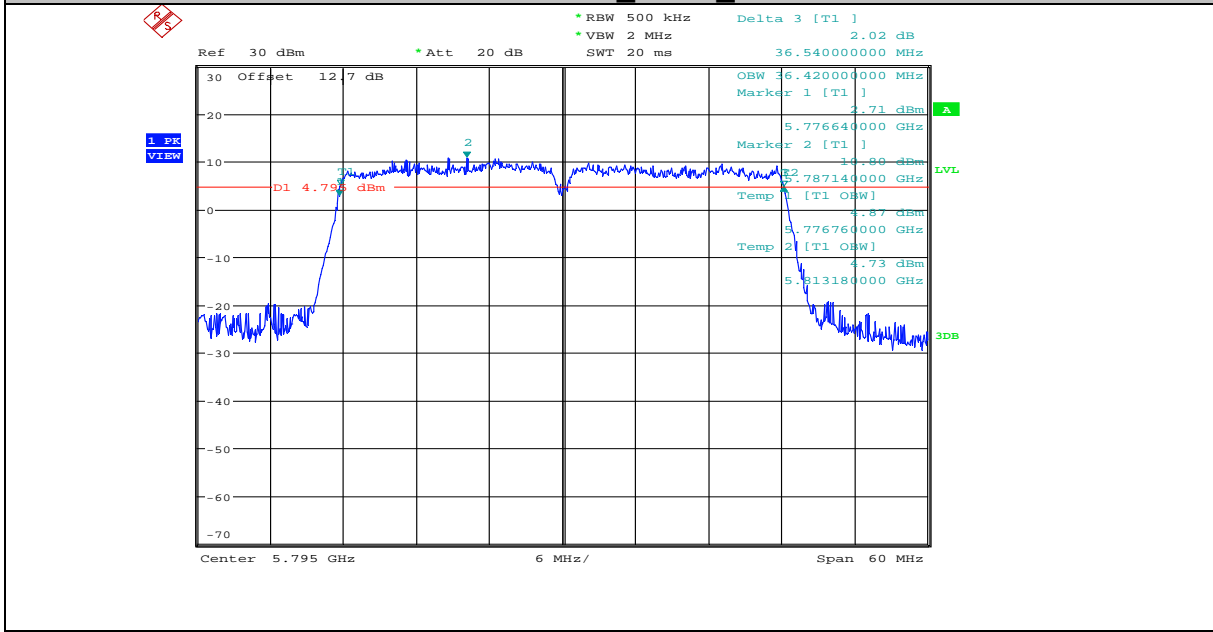

11AC40MIMO\_ANT2\_5795

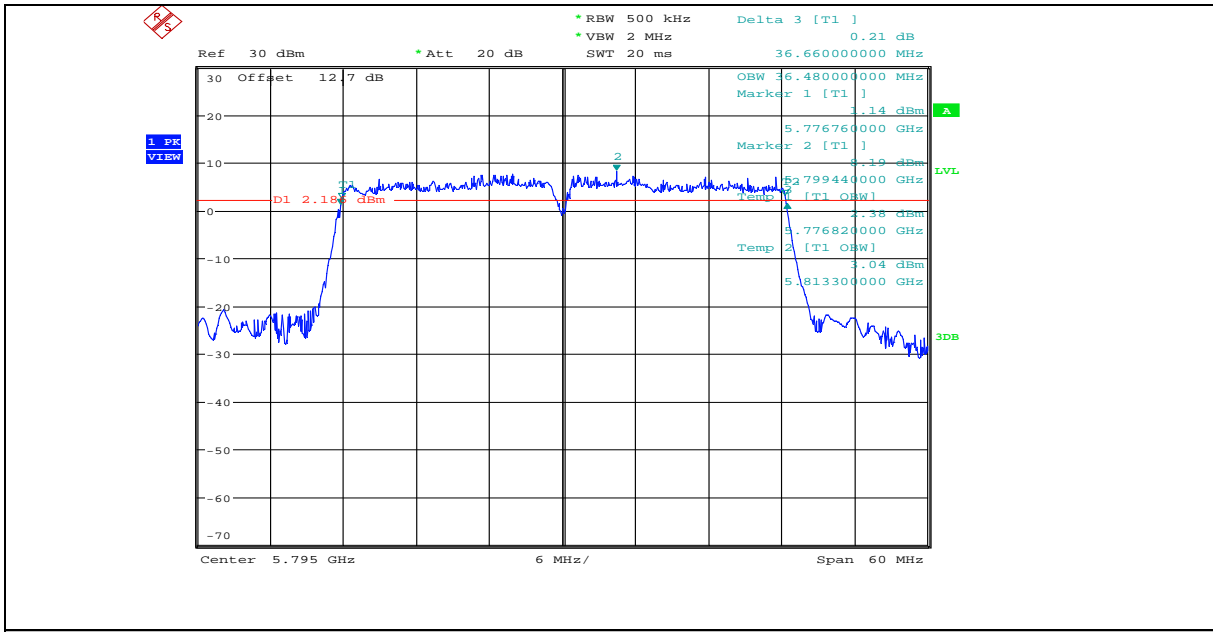

11AC40MIMO\_ANT3\_5795

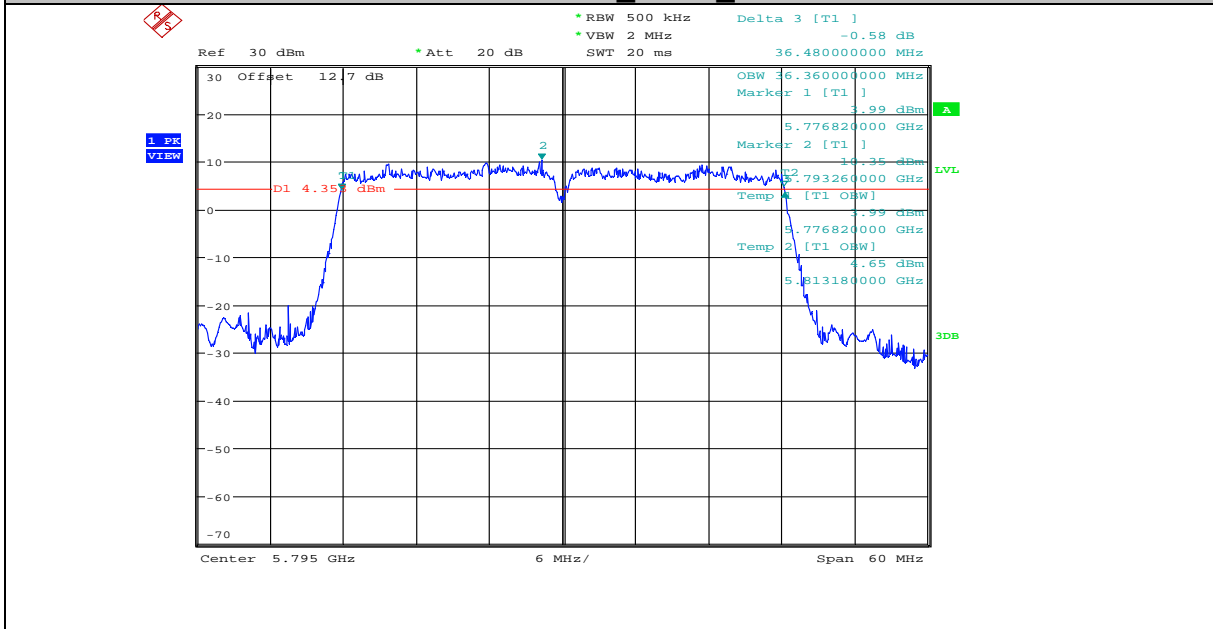

11AC80MIMO\_ANT1\_5210

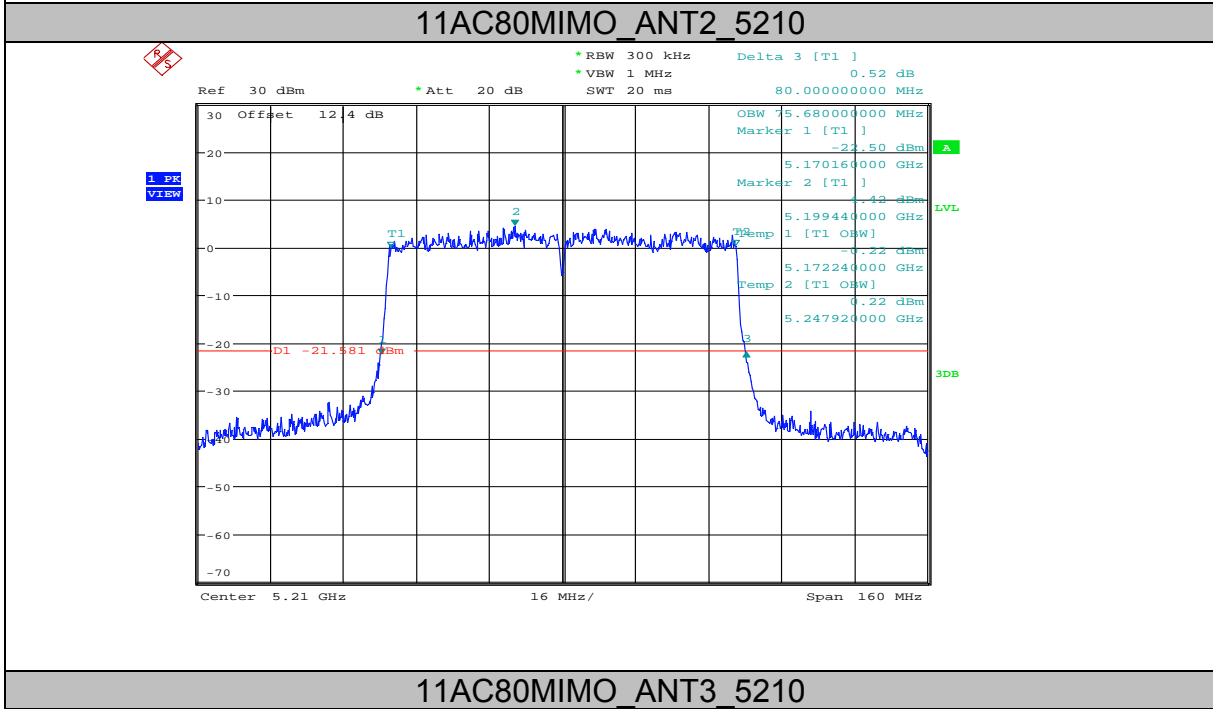
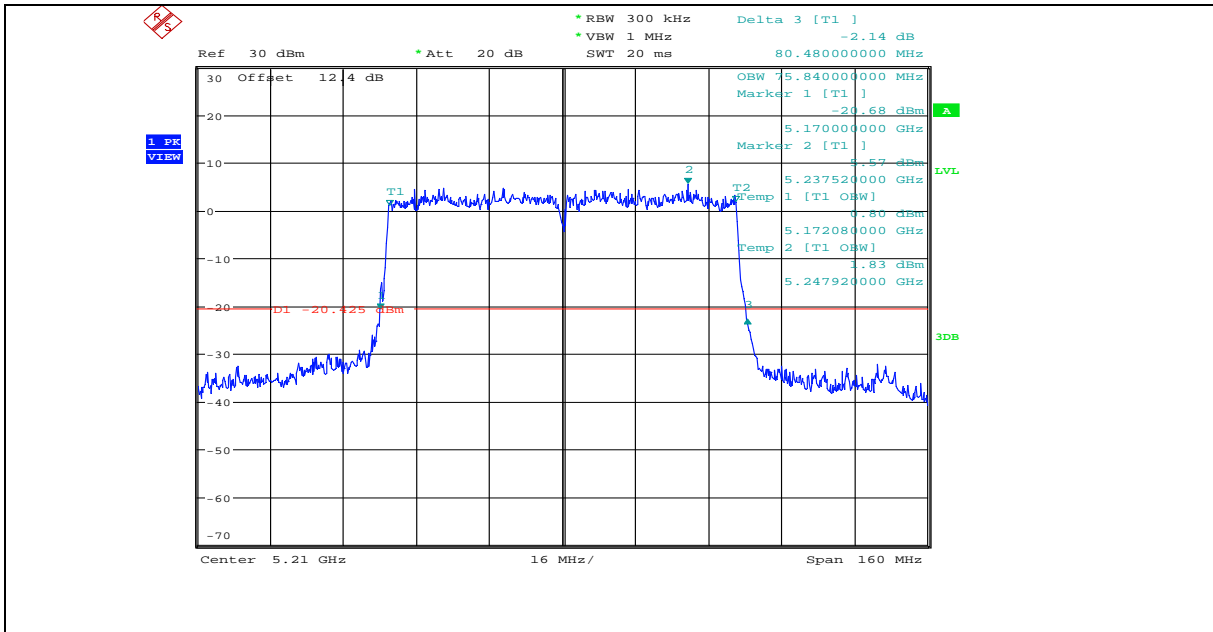

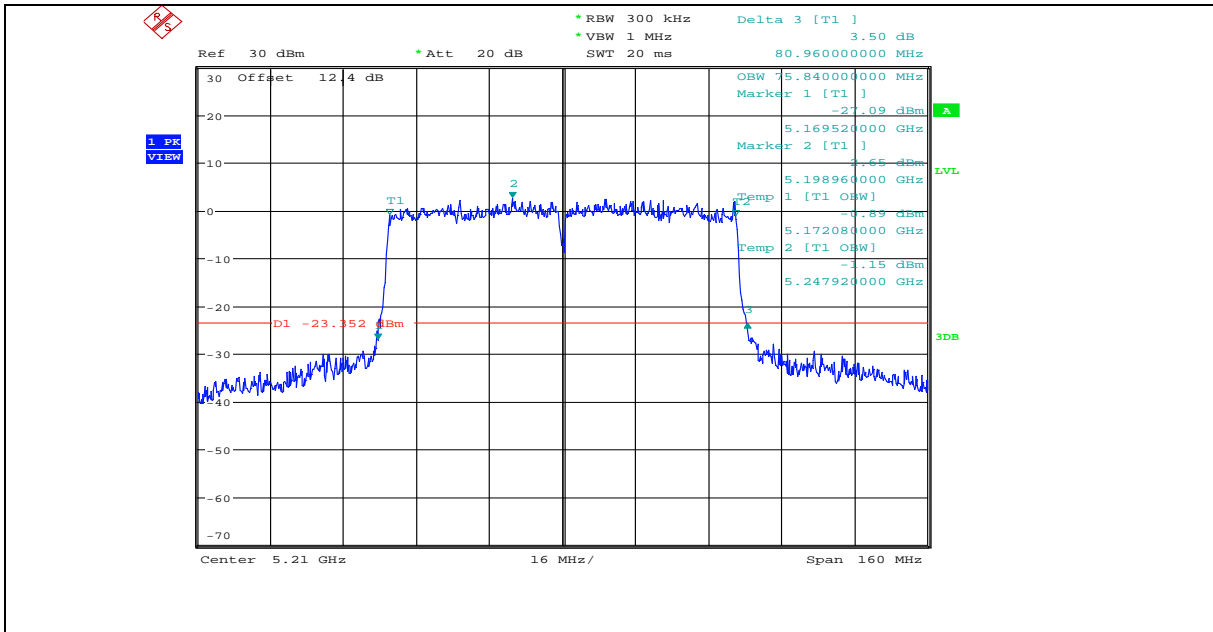

11AC80MIMO\_ANT1\_5775

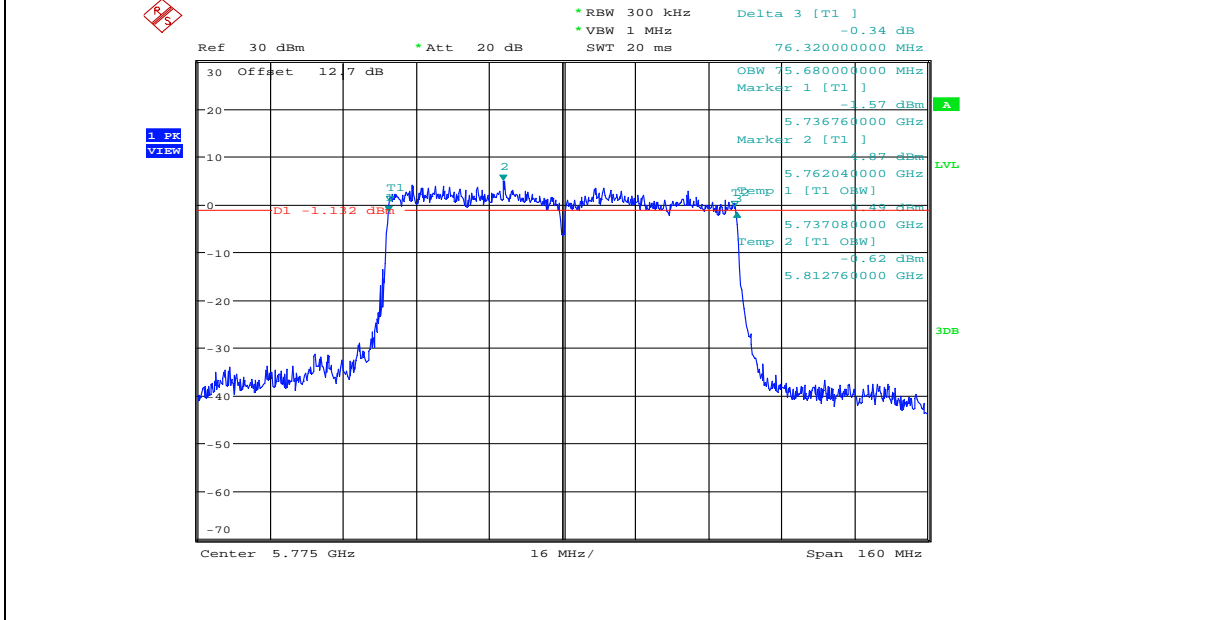

11AC80MIMO\_ANT2\_5775

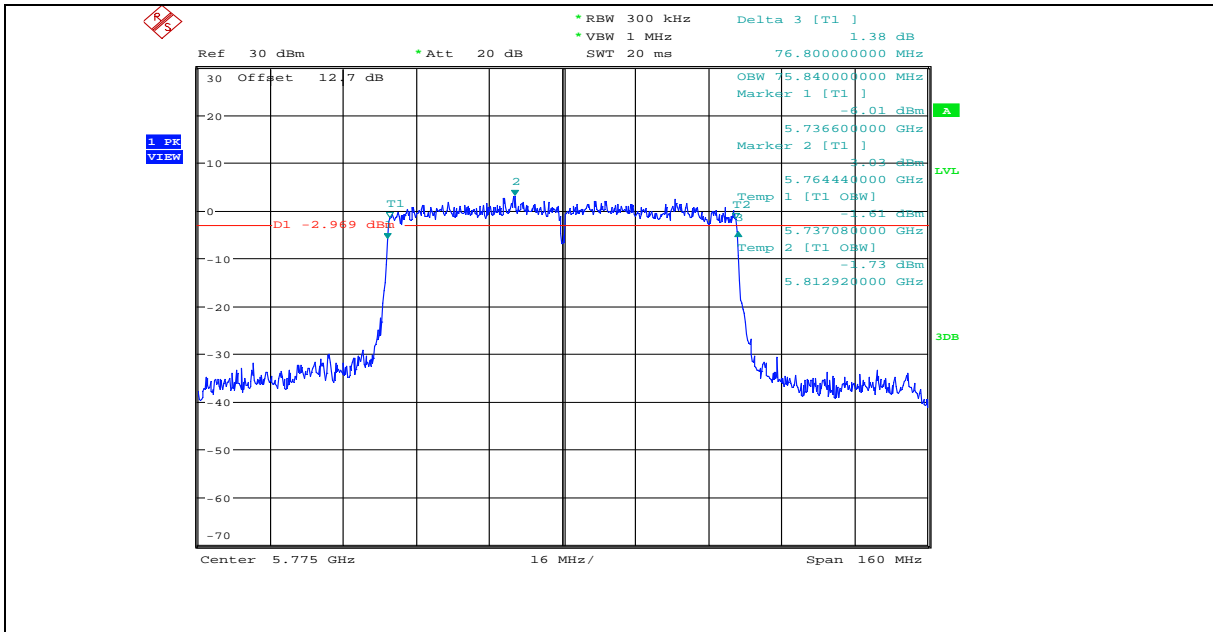

11AC80MIMO\_ANT3\_5775

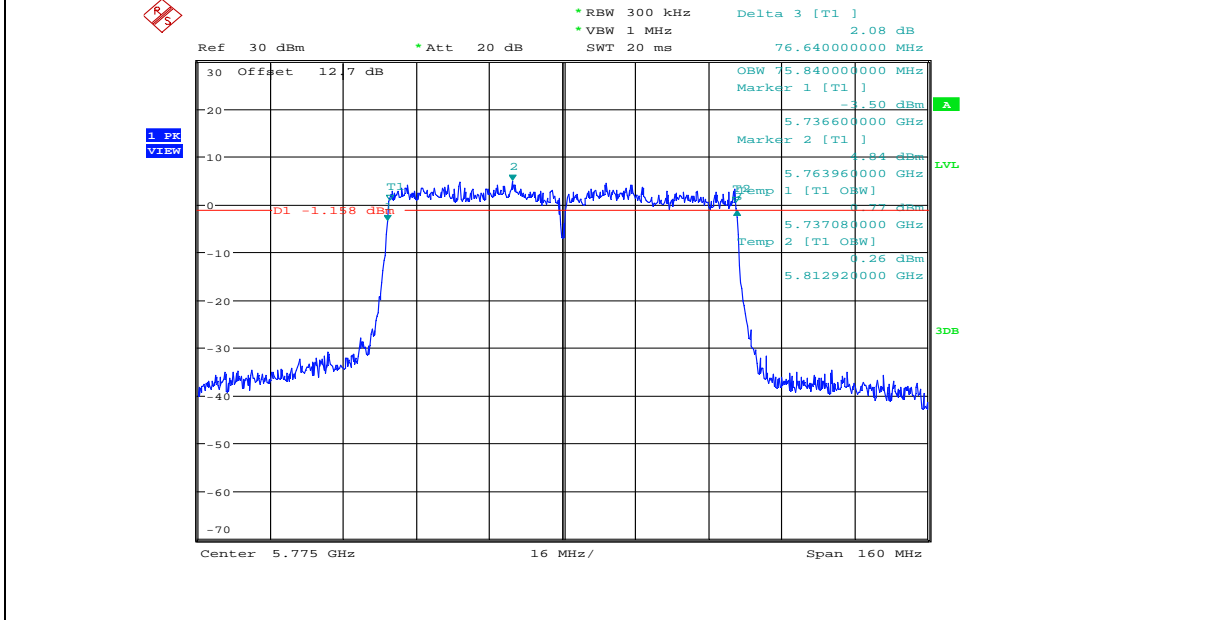

11ASISO\_ANT1\_5180

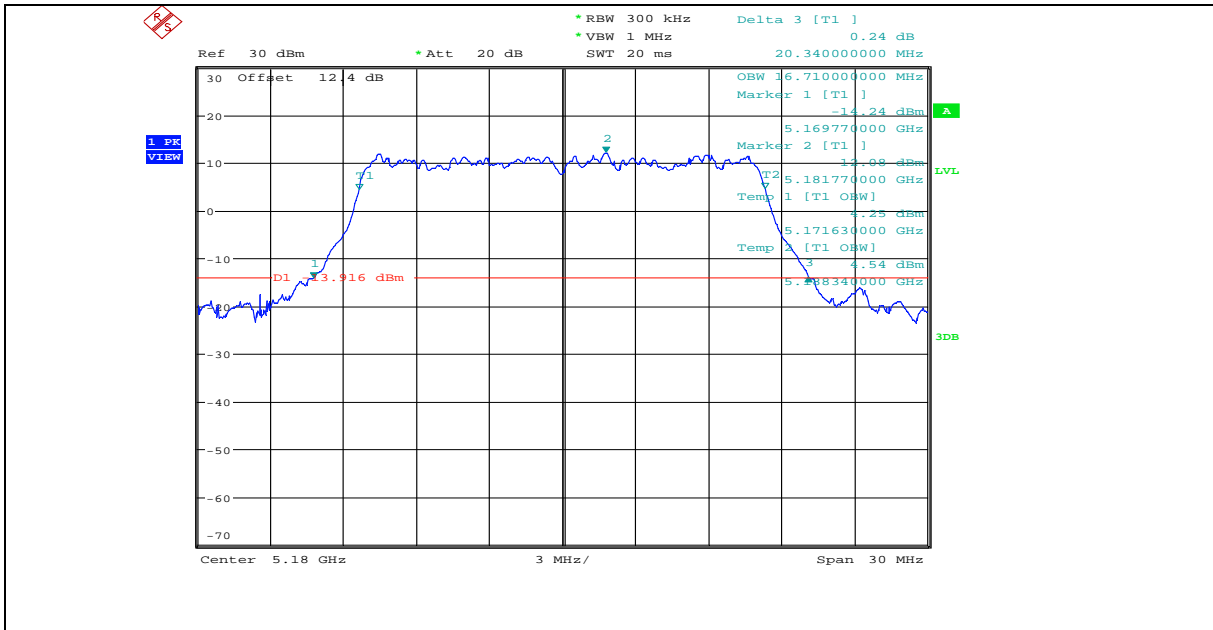

11ASISO ANT1 5200

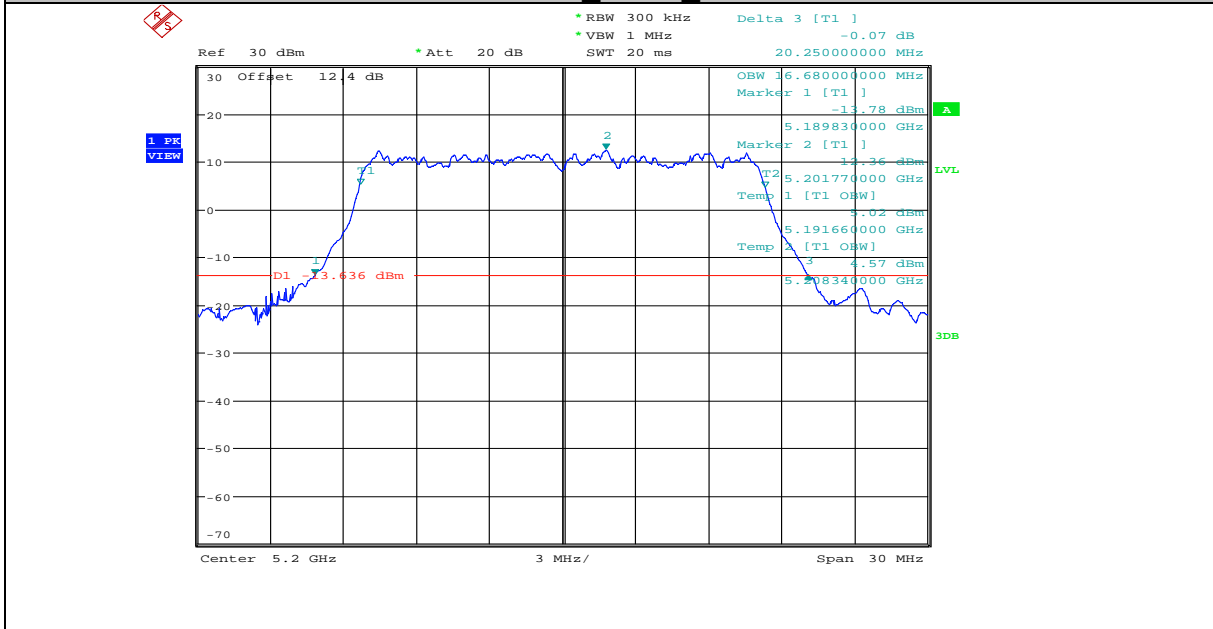

11ASISO ANT1 5240

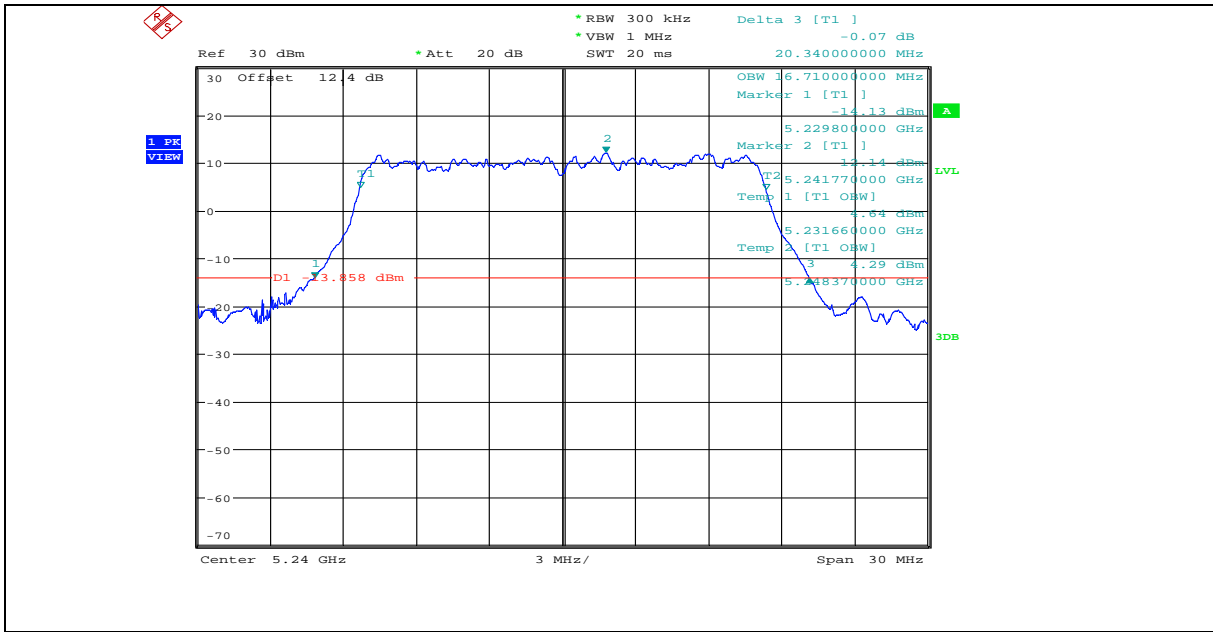

11ASISO ANT1\_5745

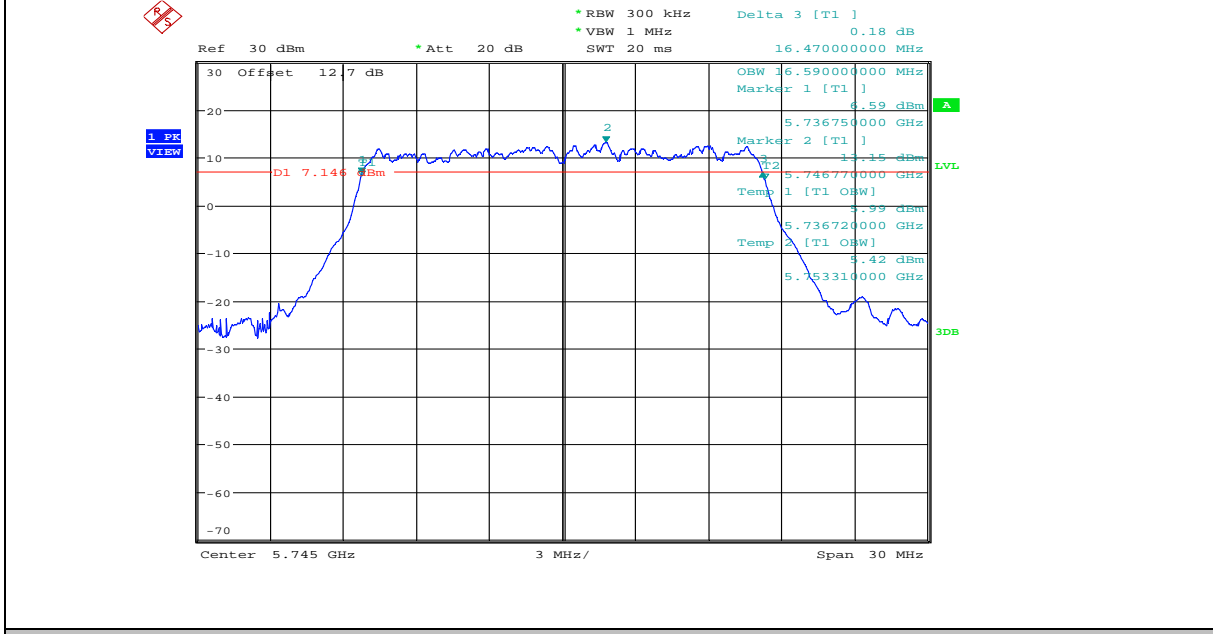

11ASISO ANT1\_5785



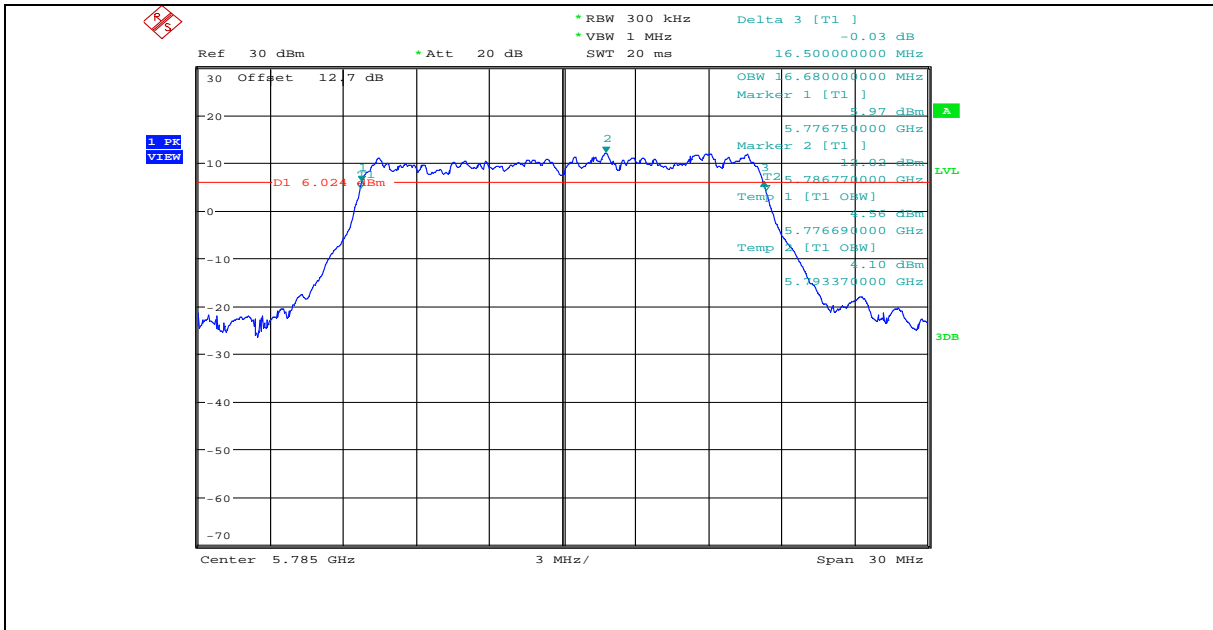

11ASISO ANT1 5825

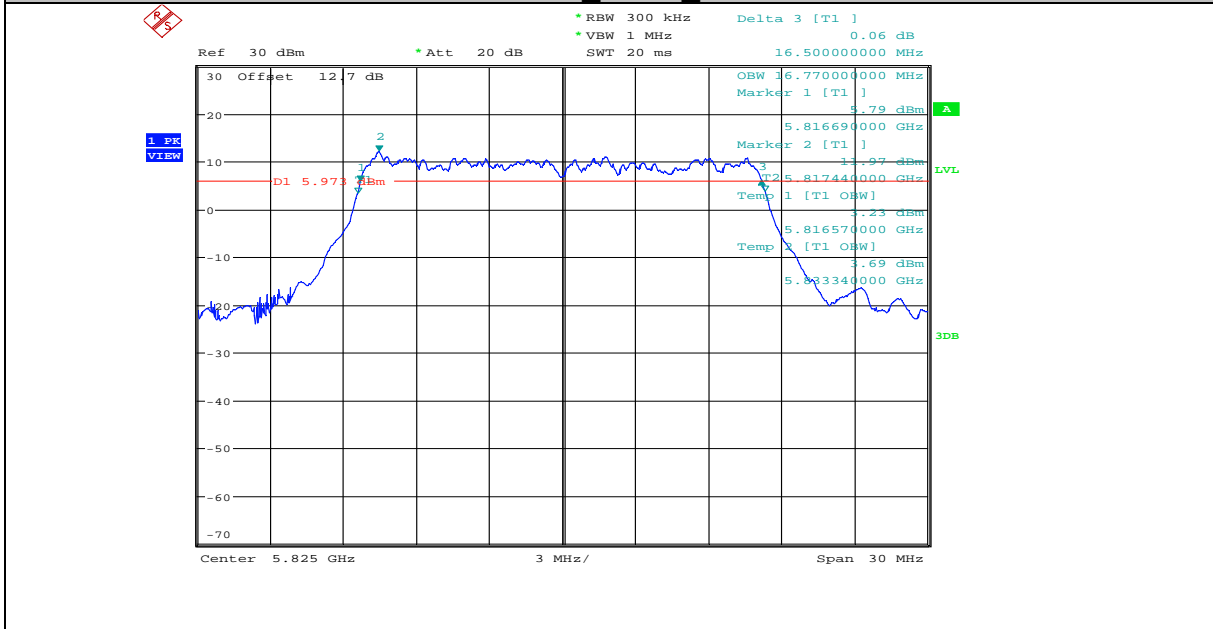

## 5. Maximum Output Power

### 5.1. Block diagram of test setup

Same as section 4.1

### 5.2. Limits

FCC Part15, Subpart E		
Test Item	Limit	Frequency Range (MHz)
Conducted Output Power	For 802.11a: 30dBm For 802.11n and 802.11ac: 27.26dBm	5150-5250
	For 802.11a: 30dBm For 802.11n and 802.11ac: 27.26dBm	5725-5850
Note: For 802.11n and 802.11ac, the EUT incorporates a MIMO function. The Antenna directional gain is 8.74dBi. The UNII-1 and UNII-3 Output Power limit is $30-(8.74-6)=27.26\text{dBm}$		

### 5.3. Test Procedure

- (1) Connect each EUT's antenna output to Spectrum Analyzer by RF cable and attenuator
- (2) Add each antenna port's results to get the total output power of EUT.

### 5.4. Test Result

Test Mode	Antenna	Channel	Result	Limit	Verdict
11N20MIMO	ANT1	5180	18.58	27.26	PASS
11N20MIMO	ANT2	5180	21.46	27.26	PASS
11N20MIMO	ANT3	5180	20.41	27.26	PASS
11N20MIMO	total	5180	25.10	27.26	PASS
11N20MIMO	ANT1	5200	18.36	27.26	PASS
11N20MIMO	ANT2	5200	18.33	27.26	PASS
11N20MIMO	ANT3	5200	17.35	27.26	PASS
11N20MIMO	total	5200	22.83	27.26	PASS
11N20MIMO	ANT1	5240	17.68	27.26	PASS
11N20MIMO	ANT2	5240	18.03	27.26	PASS
11N20MIMO	ANT3	5240	17.12	27.26	PASS
11N20MIMO	total	5240	22.39	27.26	PASS
11N20MIMO	ANT1	5745	20.51	27.26	PASS
11N20MIMO	ANT2	5745	20.45	27.26	PASS
11N20MIMO	ANT3	5745	21.23	27.26	PASS
11N20MIMO	total	5745	25.52	27.26	PASS
11N20MIMO	ANT1	5785	20.64	27.26	PASS
11N20MIMO	ANT2	5785	21.41	27.26	PASS

11N20MIMO	ANT3	5785	20.18	27.26	PASS
11N20MIMO	total	5785	25.53	27.26	PASS
11N20MIMO	ANT1	5825	19.08	27.26	PASS
11N20MIMO	ANT2	5825	21.69	27.26	PASS
11N20MIMO	ANT3	5825	20.38	27.26	PASS
11N20MIMO	total	5825	25.30	27.26	PASS
11N40MIMO	ANT1	5190	19.60	27.26	PASS
11N40MIMO	ANT2	5190	22.32	27.26	PASS
11N40MIMO	ANT3	5190	21.22	27.26	PASS
11N40MIMO	total	5190	25.94	27.26	PASS
11N40MIMO	ANT1	5230	20.96	27.26	PASS
11N40MIMO	ANT2	5230	20.28	27.26	PASS
11N40MIMO	ANT3	5230	21.29	27.26	PASS
11N40MIMO	total	5230	25.66	27.26	PASS
11N40MIMO	ANT1	5755	22.09	27.26	PASS
11N40MIMO	ANT2	5755	19.49	27.26	PASS
11N40MIMO	ANT3	5755	21.86	27.26	PASS
11N40MIMO	total	5755	26.09	27.26	PASS
11N40MIMO	ANT1	5795	22.45	27.26	PASS
11N40MIMO	ANT2	5795	21.25	27.26	PASS
11N40MIMO	ANT3	5795	21.25	27.26	PASS
11N40MIMO	total	5795	26.51	27.26	PASS
11AC20MIMO	ANT1	5180	20.49	27.26	PASS
11AC20MIMO	ANT2	5180	20.02	27.26	PASS
11AC20MIMO	ANT3	5180	19.27	27.26	PASS
11AC20MIMO	total	5180	24.73	27.26	PASS
11AC20MIMO	ANT1	5200	18.43	27.26	PASS
11AC20MIMO	ANT2	5200	19.48	27.26	PASS
11AC20MIMO	ANT3	5200	19.59	27.26	PASS
11AC20MIMO	total	5200	23.97	27.26	PASS
11AC20MIMO	ANT1	5240	19.88	27.26	PASS
11AC20MIMO	ANT2	5240	19.24	27.26	PASS
11AC20MIMO	ANT3	5240	16.69	27.26	PASS
11AC20MIMO	total	5240	23.57	27.26	PASS
11AC20MIMO	ANT1	5745	19.81	27.26	PASS
11AC20MIMO	ANT2	5745	18.40	27.26	PASS
11AC20MIMO	ANT3	5745	19.41	27.26	PASS
11AC20MIMO	total	5745	24.01	27.26	PASS
11AC20MIMO	ANT1	5785	17.86	27.26	PASS

11AC20MIMO	ANT2	5785	15.79	27.26	PASS
11AC20MIMO	ANT3	5785	18.09	27.26	PASS
11AC20MIMO	total	5785	22.15	27.26	PASS
11AC20MIMO	ANT1	5825	16.90	27.26	PASS
11AC20MIMO	ANT2	5825	17.48	27.26	PASS
11AC20MIMO	ANT3	5825	17.69	27.26	PASS
11AC20MIMO	total	5825	22.15	27.26	PASS
11AC40MIMO	ANT1	5190	19.08	27.26	PASS
11AC40MIMO	ANT2	5190	20.30	27.26	PASS
11AC40MIMO	ANT3	5190	19.53	27.26	PASS
11AC40MIMO	total	5190	24.43	27.26	PASS
11AC40MIMO	ANT1	5230	19.93	27.26	PASS
11AC40MIMO	ANT2	5230	19.39	27.26	PASS
11AC40MIMO	ANT3	5230	16.91	27.26	PASS
11AC40MIMO	total	5230	23.69	27.26	PASS
11AC40MIMO	ANT1	5755	19.58	27.26	PASS
11AC40MIMO	ANT2	5755	19.85	27.26	PASS
11AC40MIMO	ANT3	5755	19.67	27.26	PASS
11AC40MIMO	total	5755	24.51	27.26	PASS
11AC40MIMO	ANT1	5795	19.55	27.26	PASS
11AC40MIMO	ANT2	5795	16.59	27.26	PASS
11AC40MIMO	ANT3	5795	18.72	27.26	PASS
11AC40MIMO	total	5795	23.24	27.26	PASS
11AC80MIMO	ANT1	5210	20.04	27.26	PASS
11AC80MIMO	ANT2	5210	19.25	27.26	PASS
11AC80MIMO	ANT3	5210	17.55	27.26	PASS
11AC80MIMO	total	5210	23.85	27.26	PASS
11AC80MIMO	ANT1	5775	18.98	27.26	PASS
11AC80MIMO	ANT2	5775	17.92	27.26	PASS
11AC80MIMO	ANT3	5775	19.56	27.26	PASS
11AC80MIMO	total	5775	23.66	27.26	PASS
11ASISO	ANT1	5180	20.78	30	PASS
11ASISO	ANT1	5200	20.91	30	PASS
11ASISO	ANT1	5240	20.62	30	PASS
11ASISO	ANT1	5745	21.44	30	PASS
11ASISO	ANT1	5785	20.33	30	PASS
11ASISO	ANT1	5825	19.98	30	PASS

### 5.5. Original test data

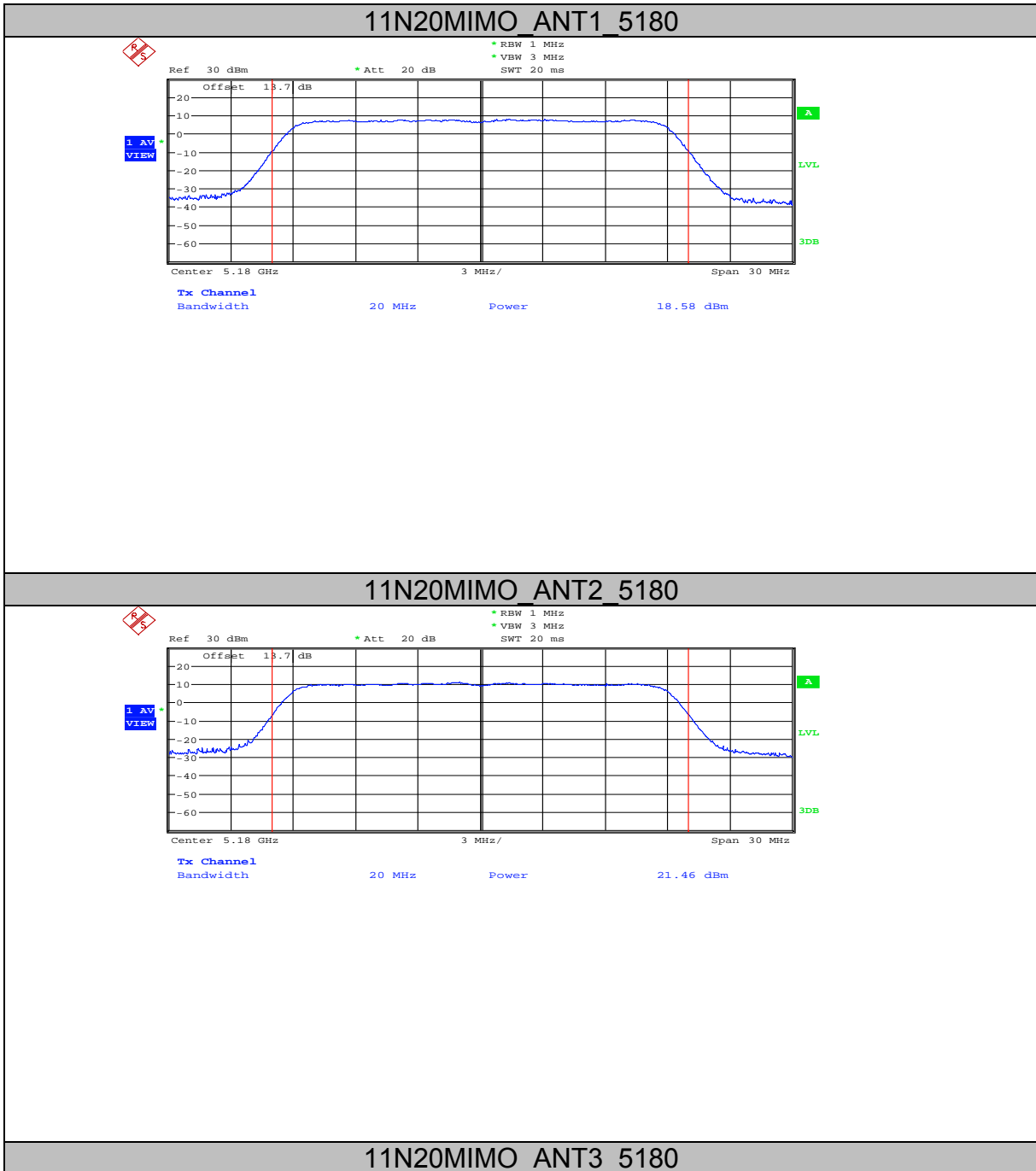

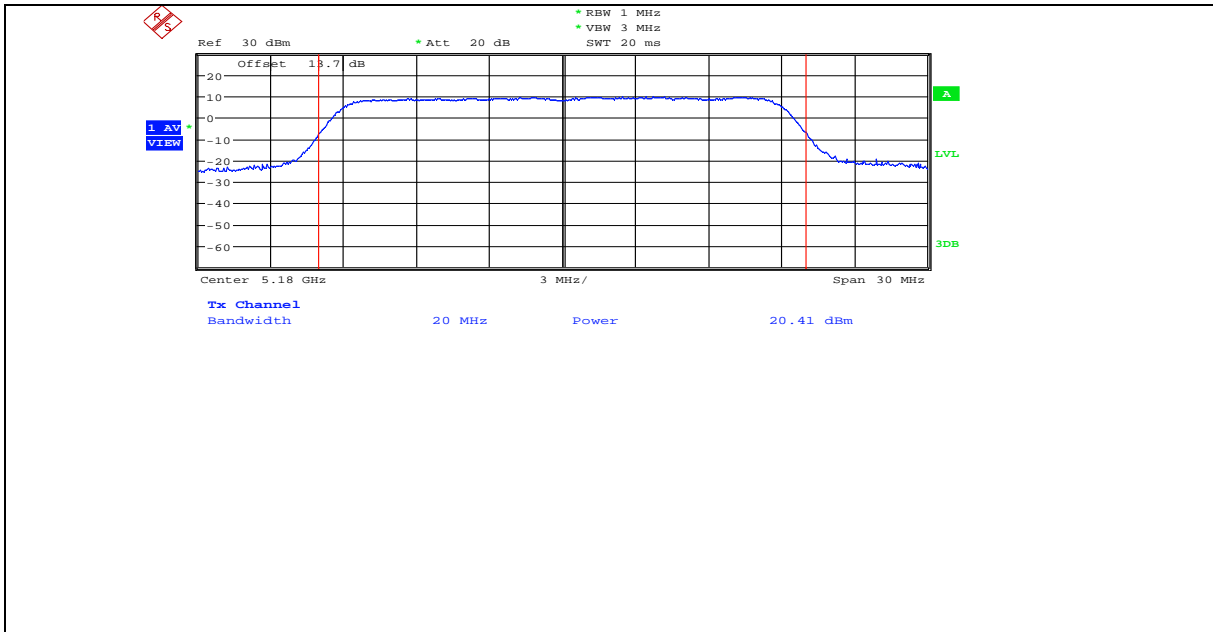

11N20MIMO\_ANT1\_5200

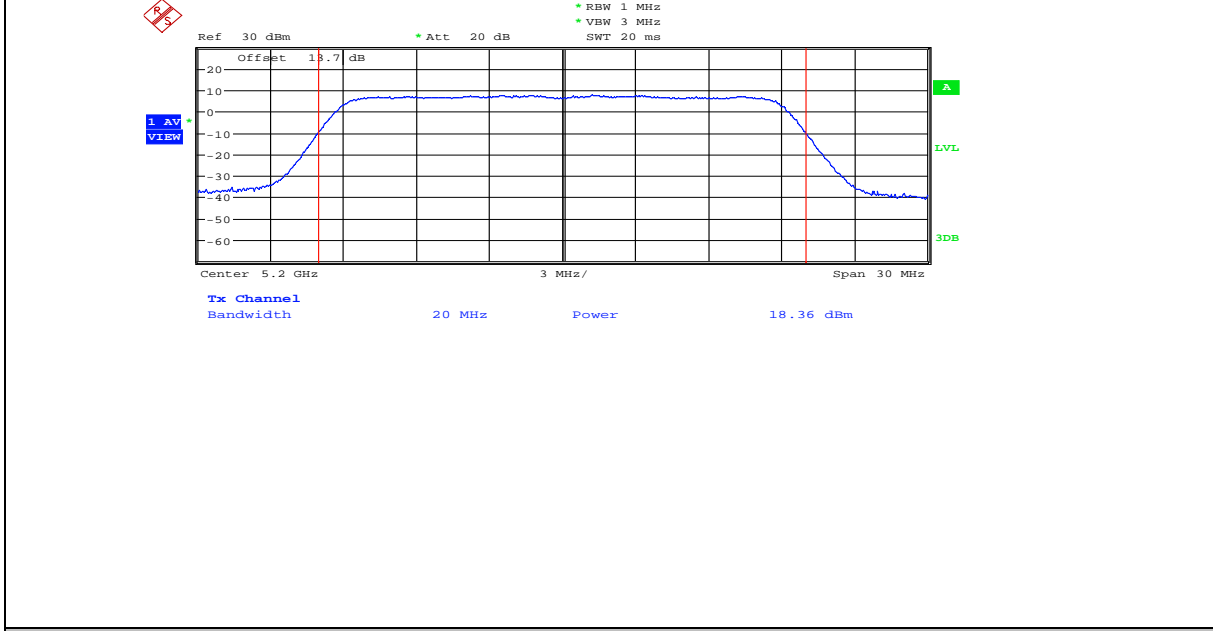

11N20MIMO\_ANT2\_5200

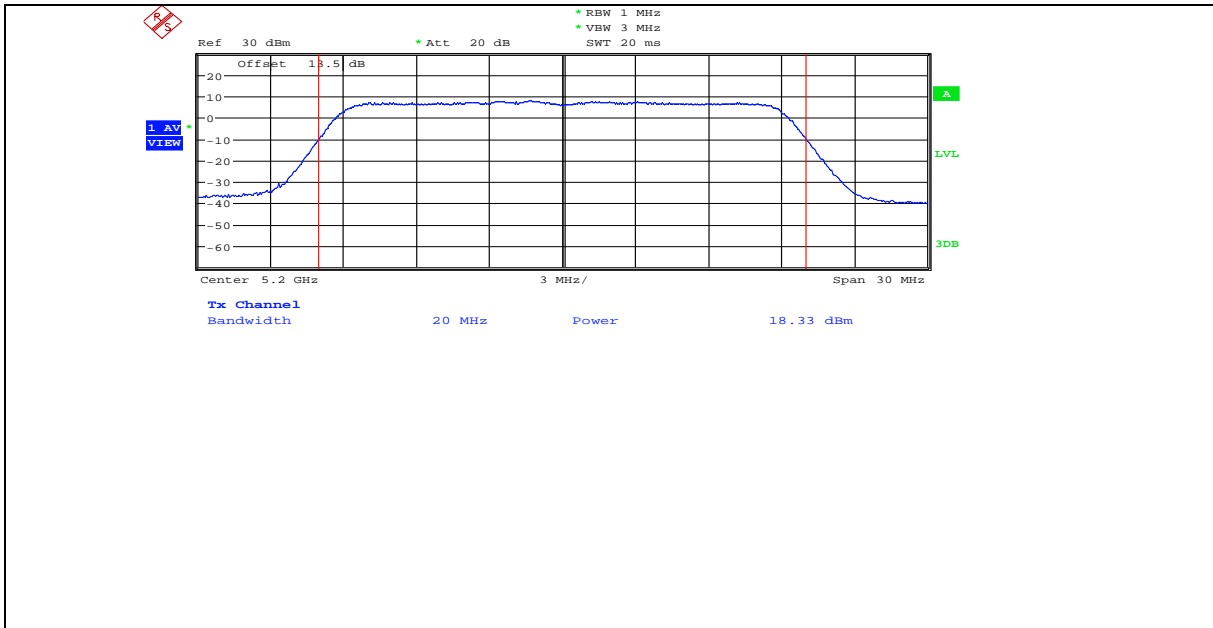

11N20MIMO\_ANT3\_5200

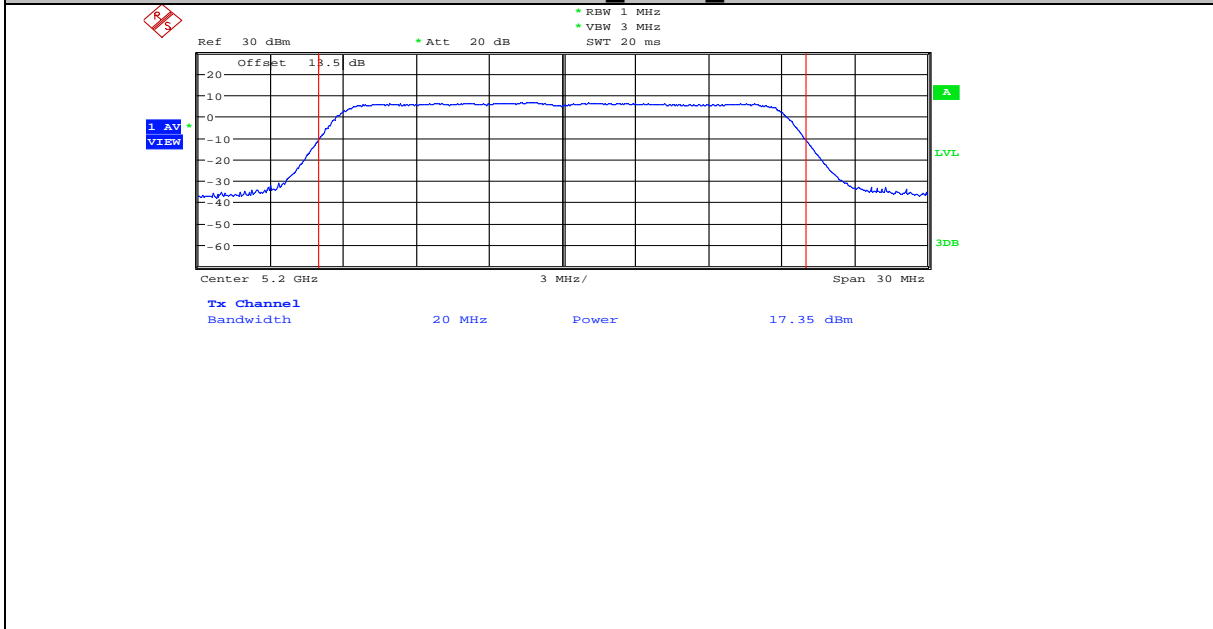

11N20MIMO\_ANT1\_5240

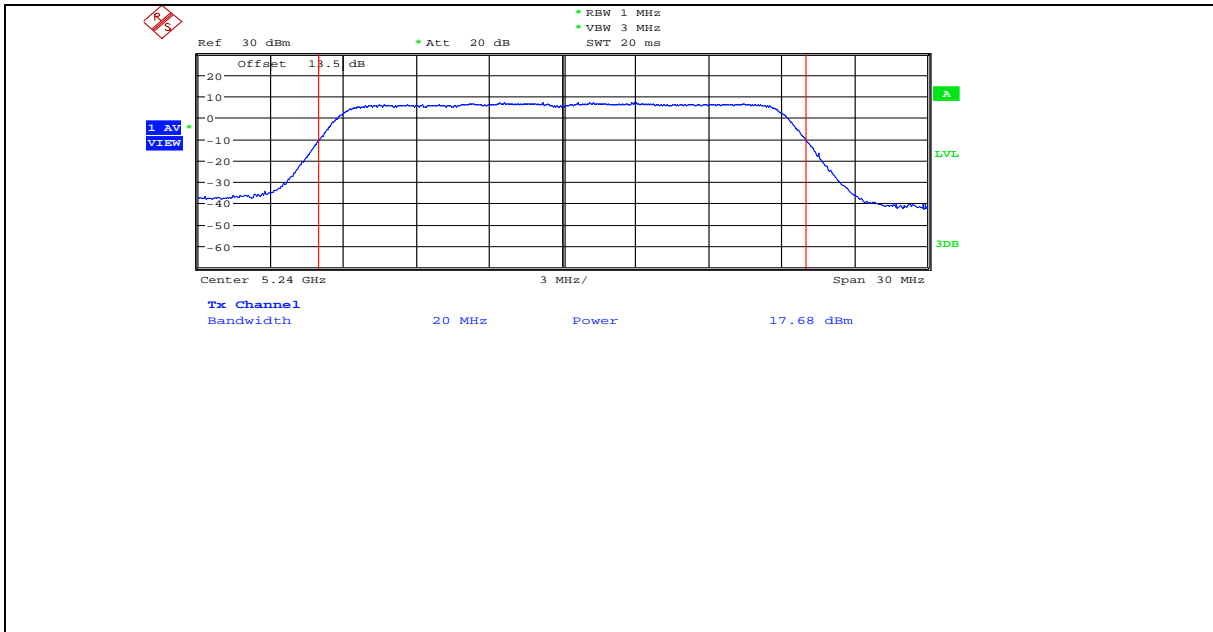

11N20MIMO\_ANT2\_5240

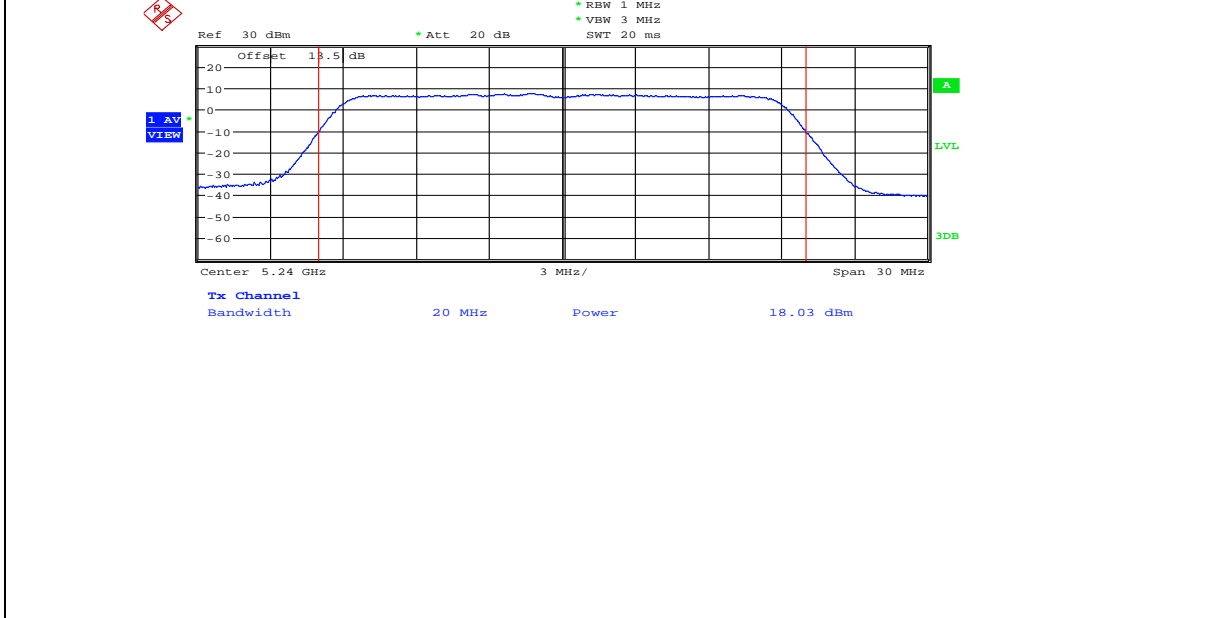

11N20MIMO\_ANT3\_5240



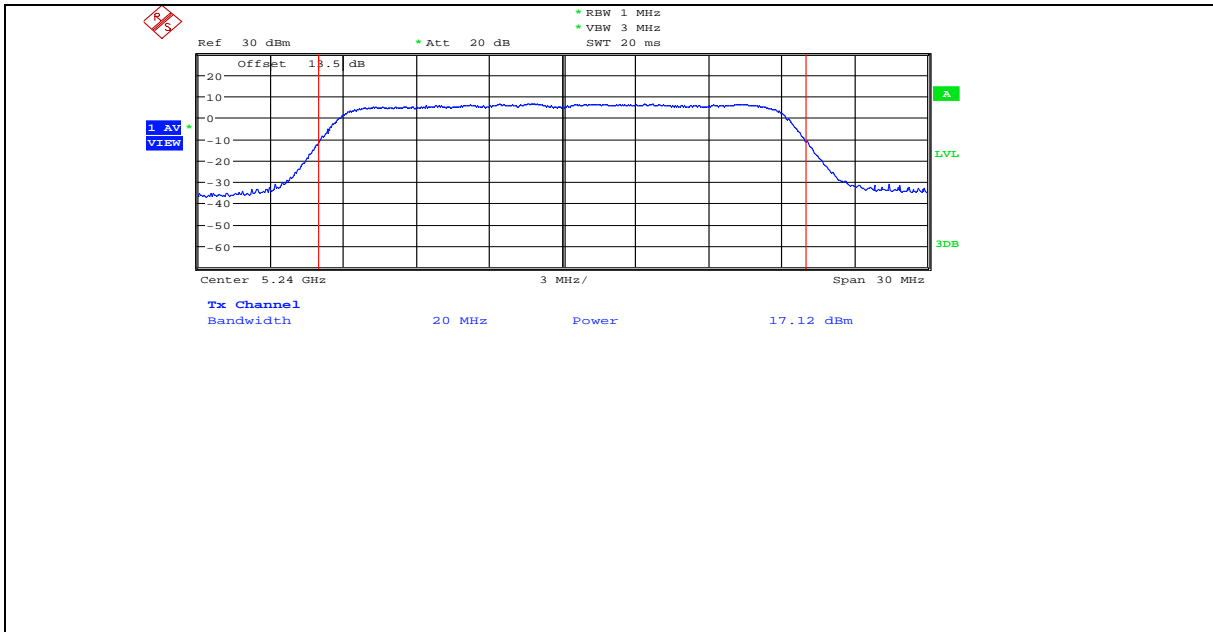

11N20MIMO\_ANT1\_5745

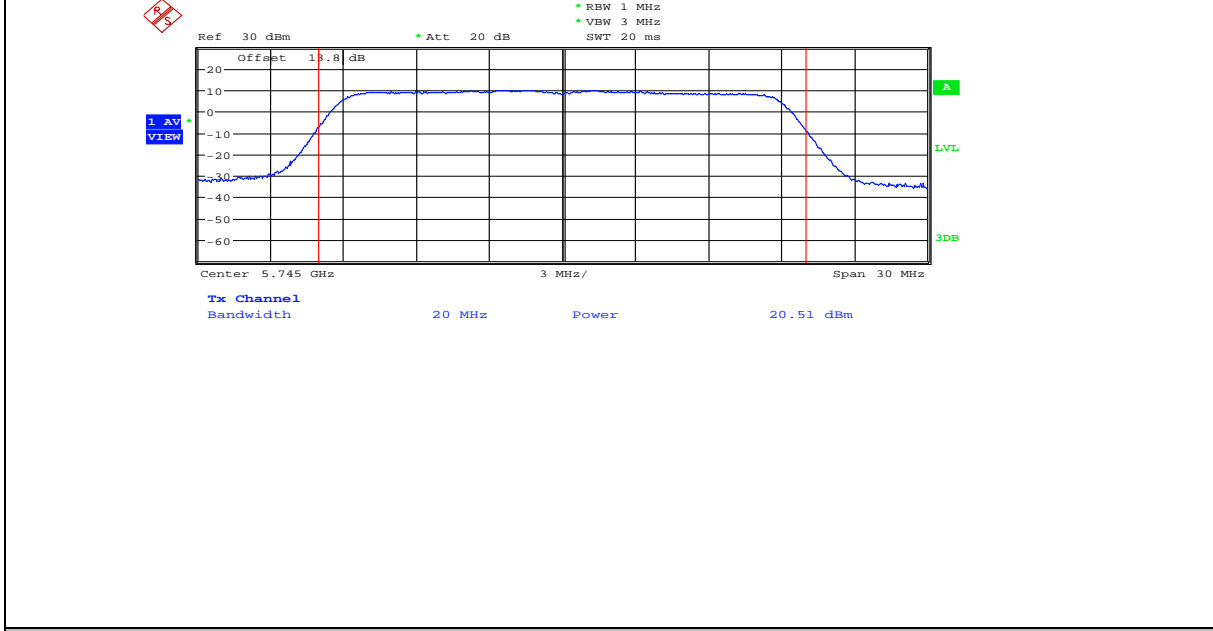

11N20MIMO\_ANT2\_5745

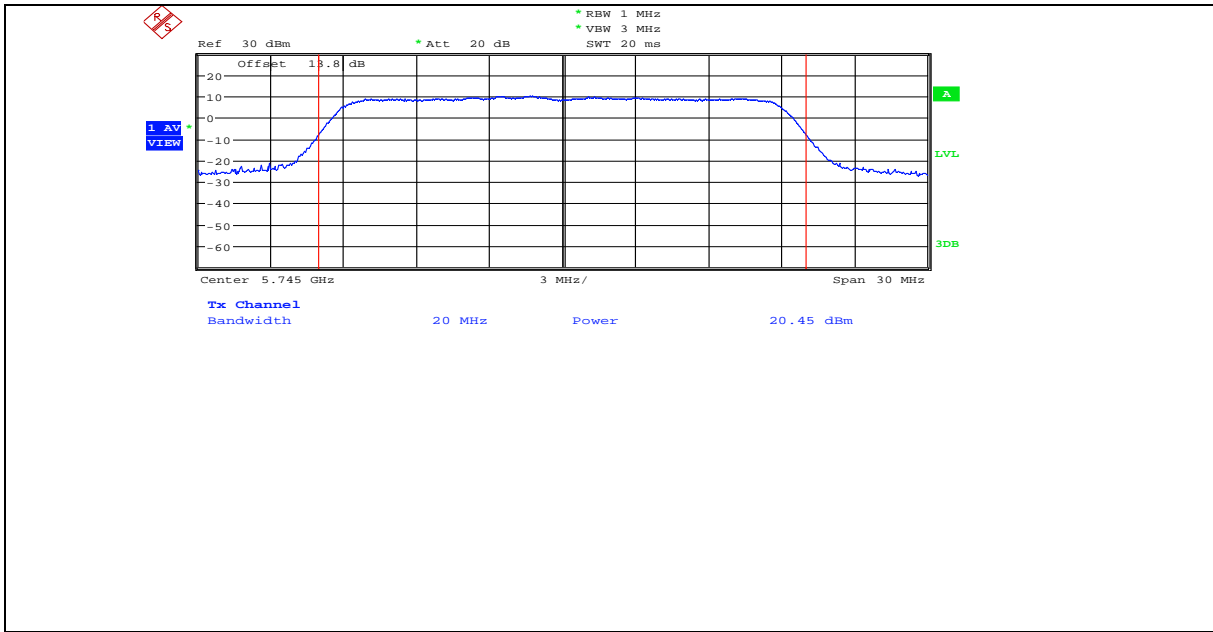

11N20MIMO\_ANT3\_5745

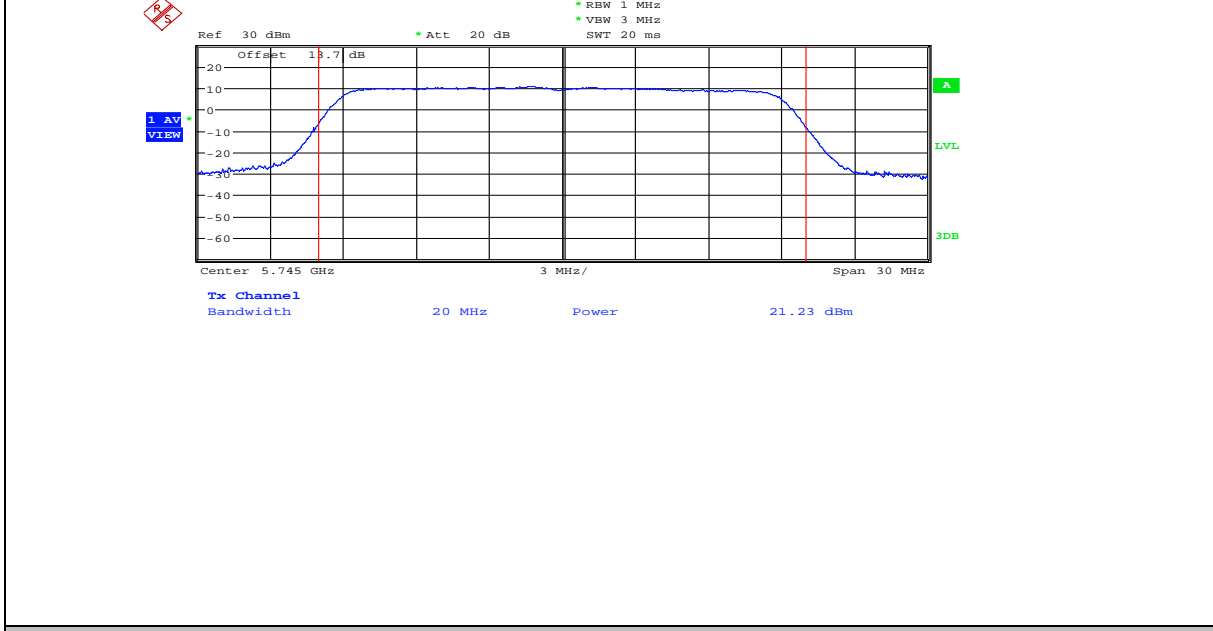

11N20MIMO\_ANT1\_5785

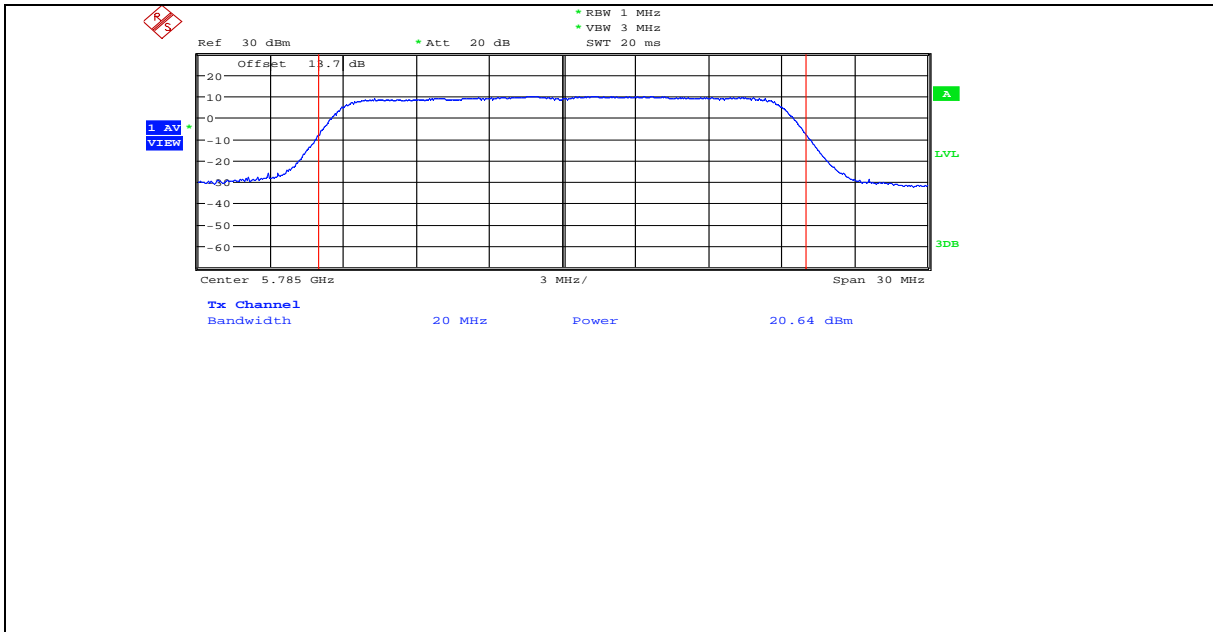

11N20MIMO\_ANT2\_5785

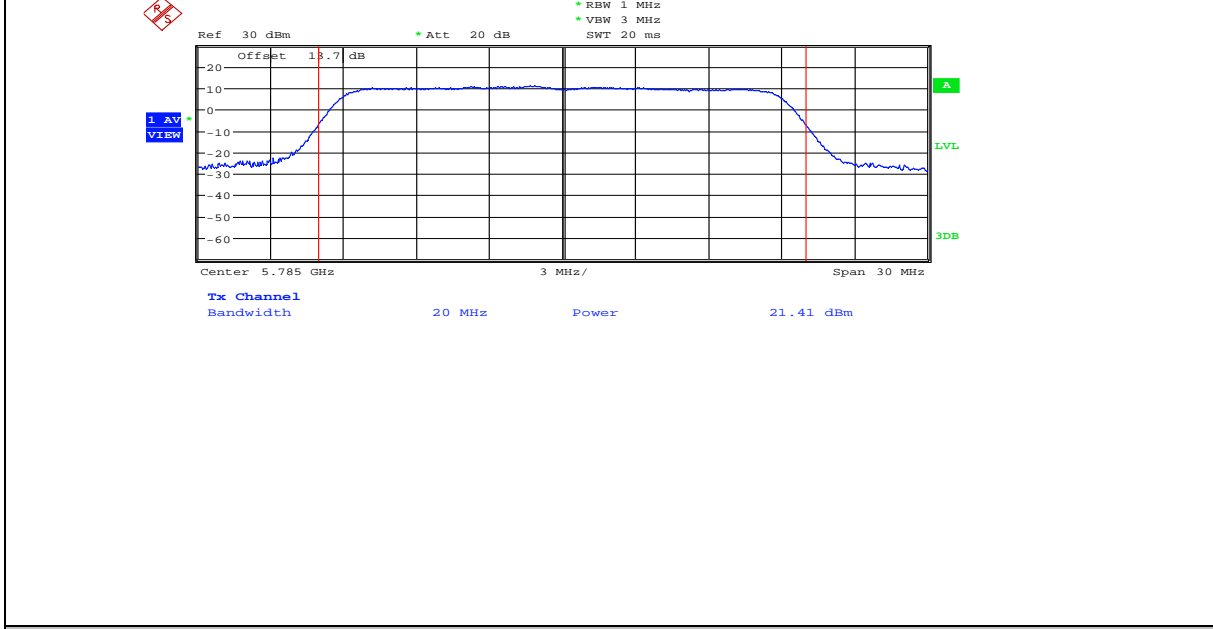

11N20MIMO\_ANT3\_5785

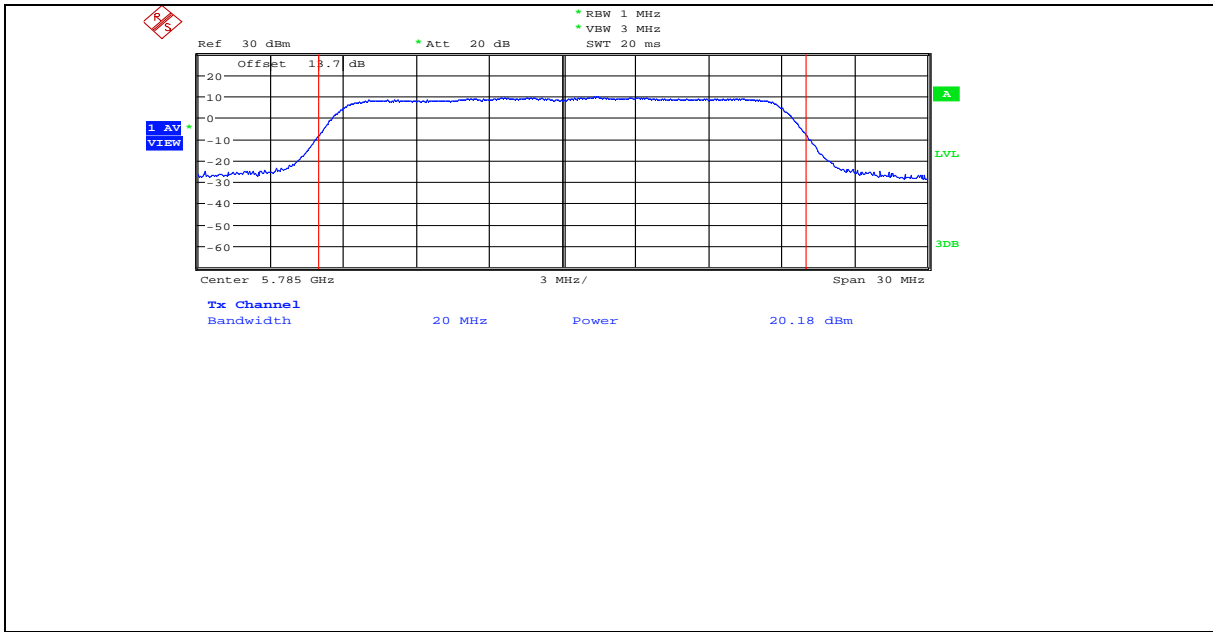

11N20MIMO\_ANT1\_5825

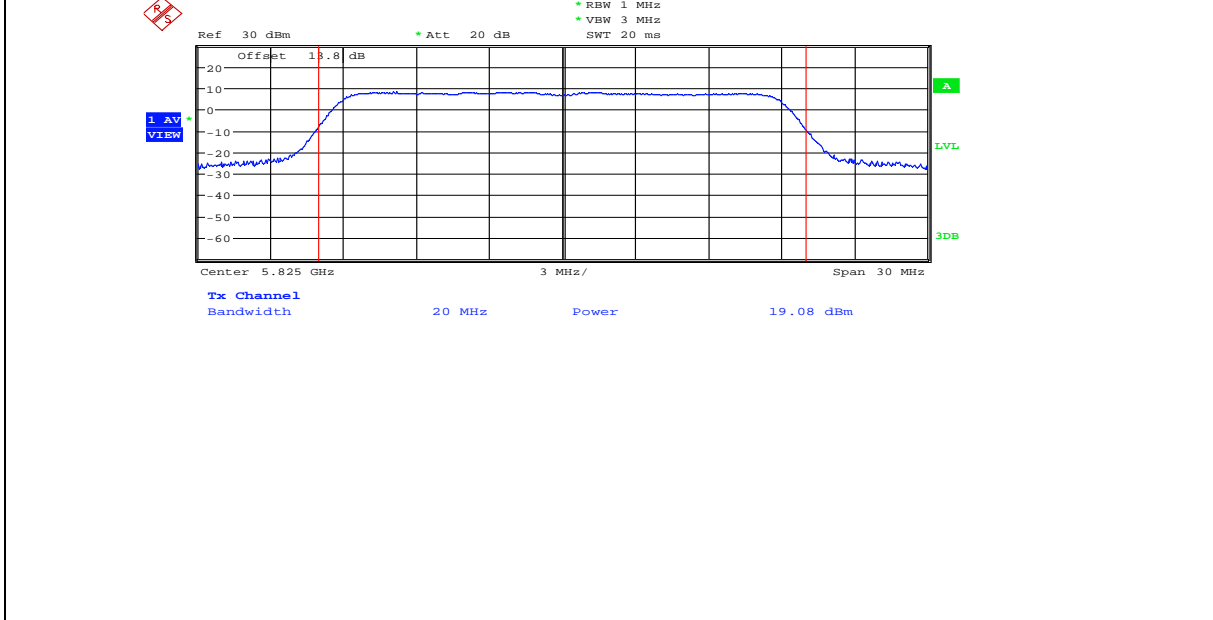

11N20MIMO\_ANT2\_5825

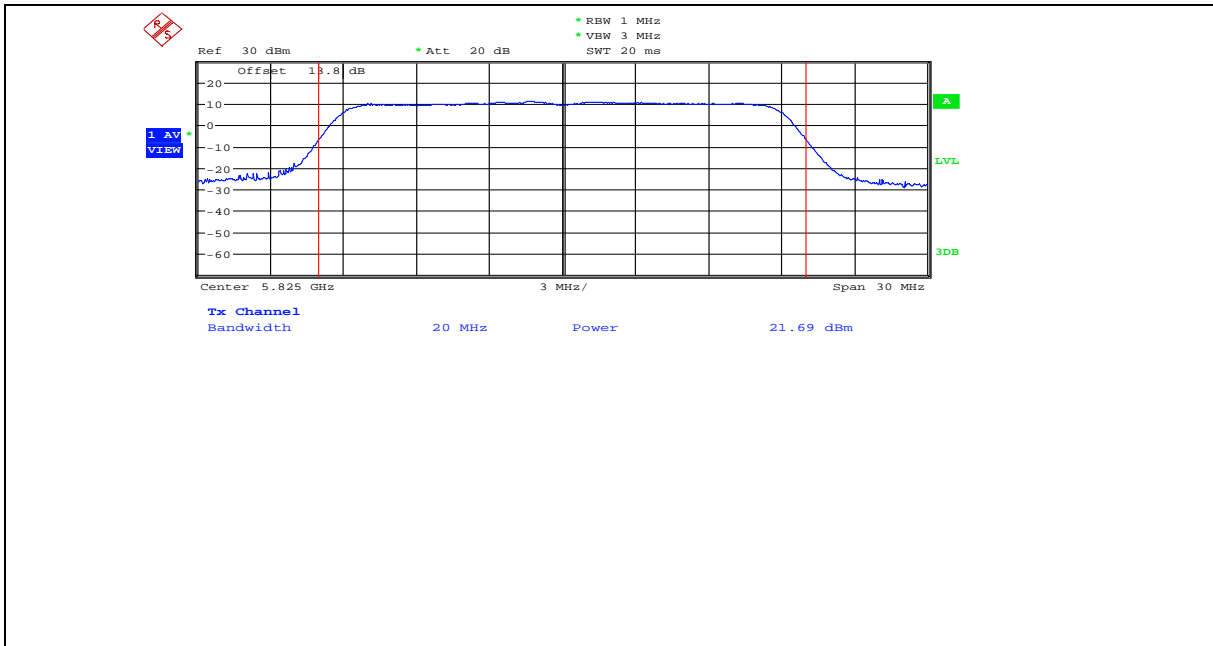

11N20MIMO\_ANT3\_5825

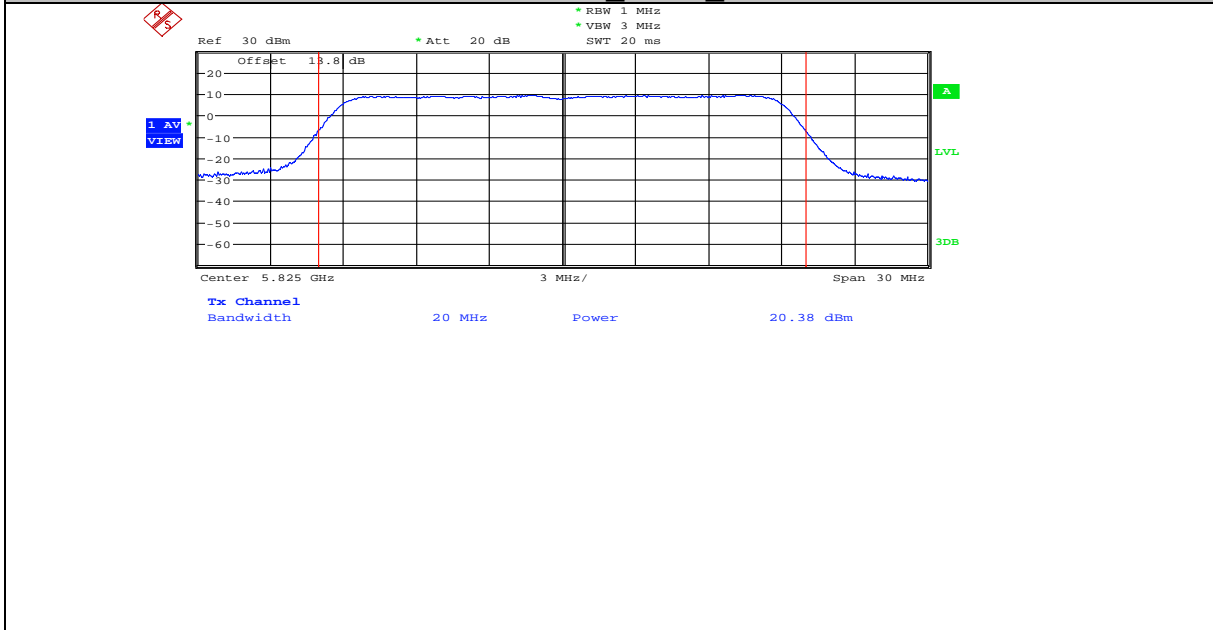

11N40MIMO\_ANT1\_5190

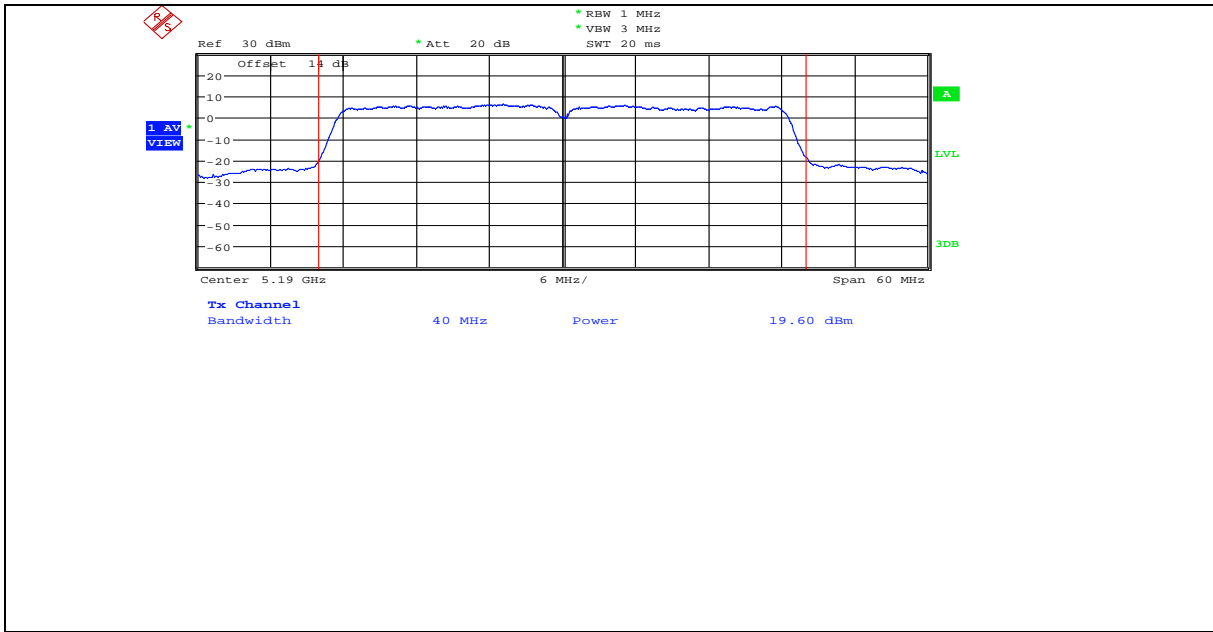

11N40MIMO\_ANT2\_5190

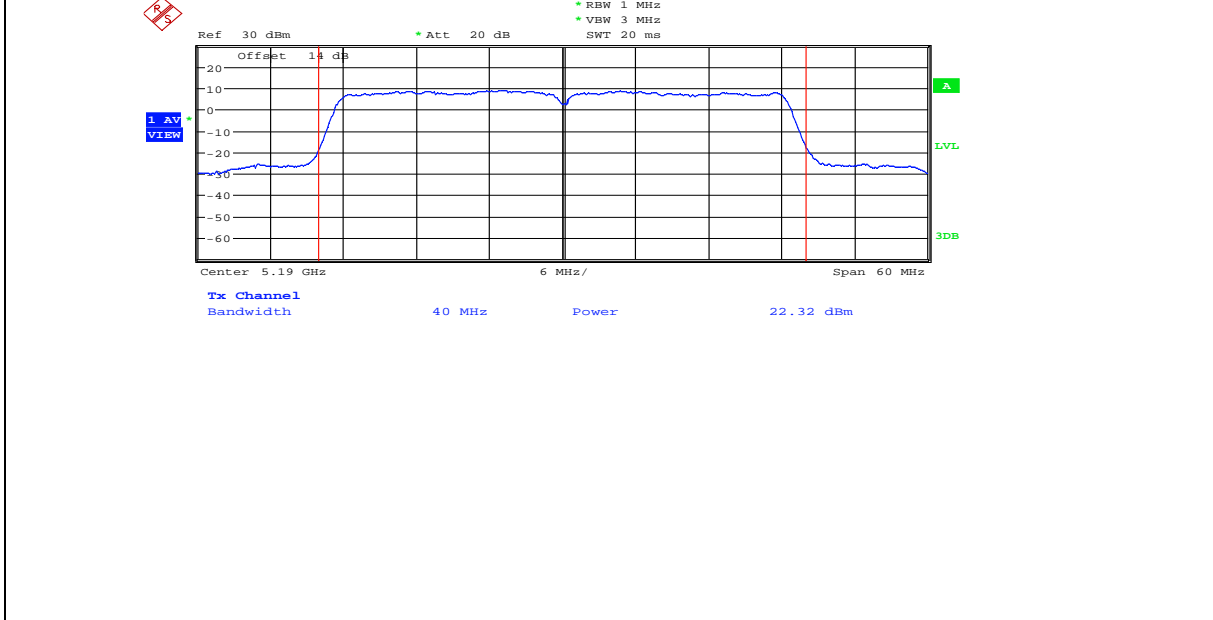

11N40MIMO\_ANT3\_5190

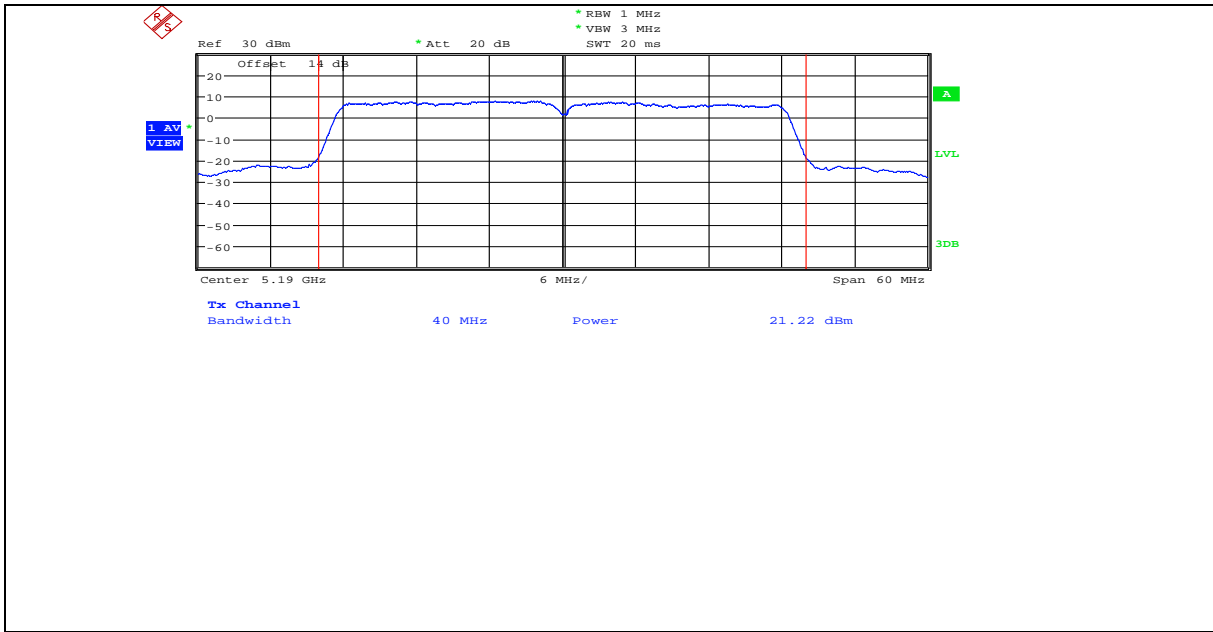

11N40MIMO\_ANT1\_5230

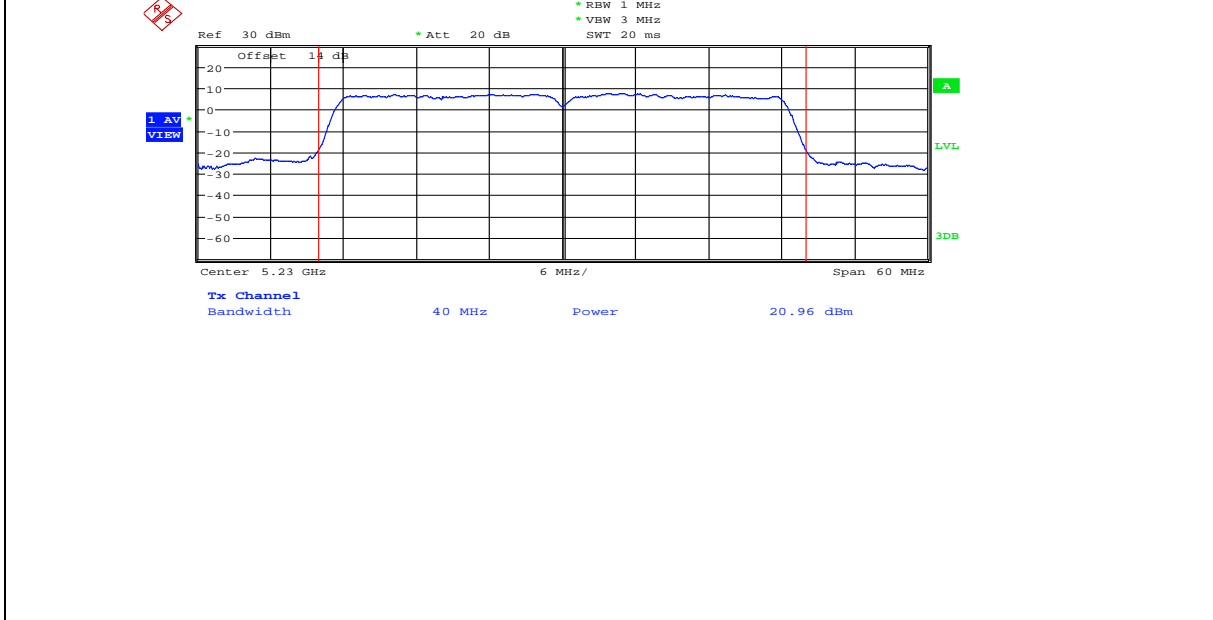

11N40MIMO\_ANT2\_5230

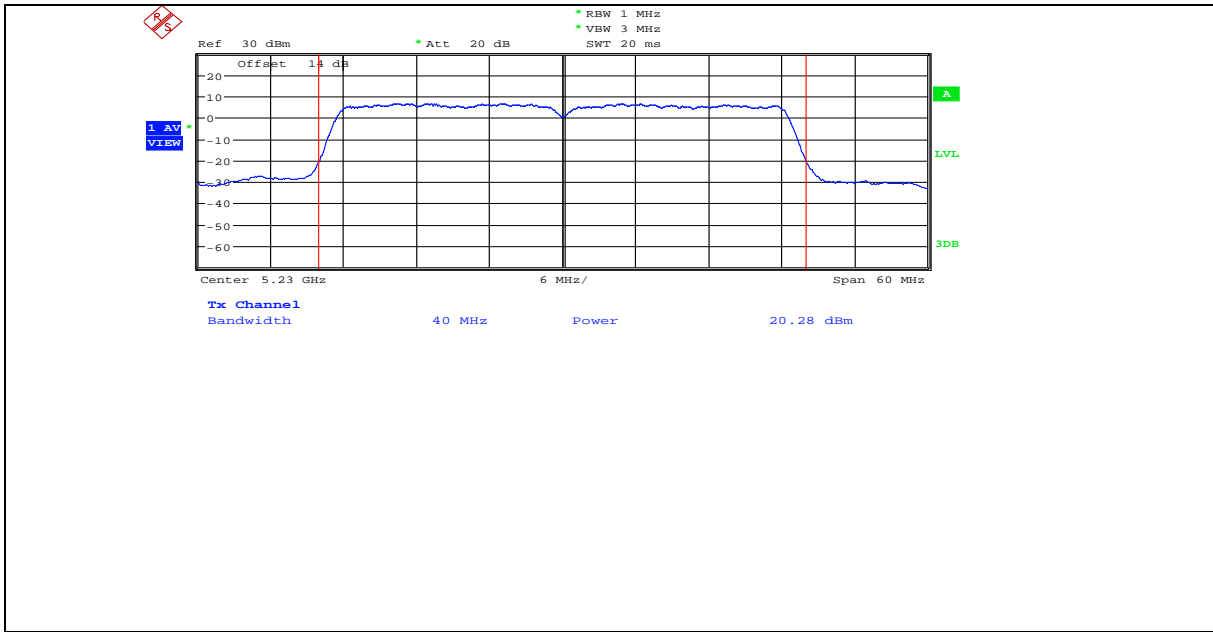

11N40MIMO ANT3 5230

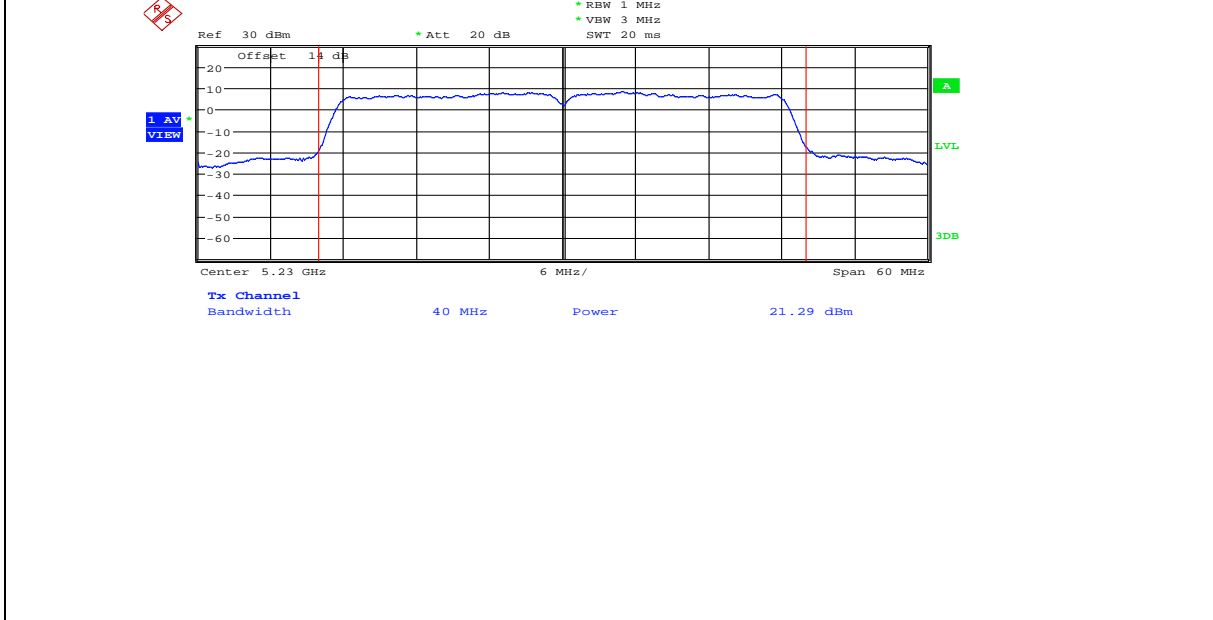

11N40MIMO ANT1 5755



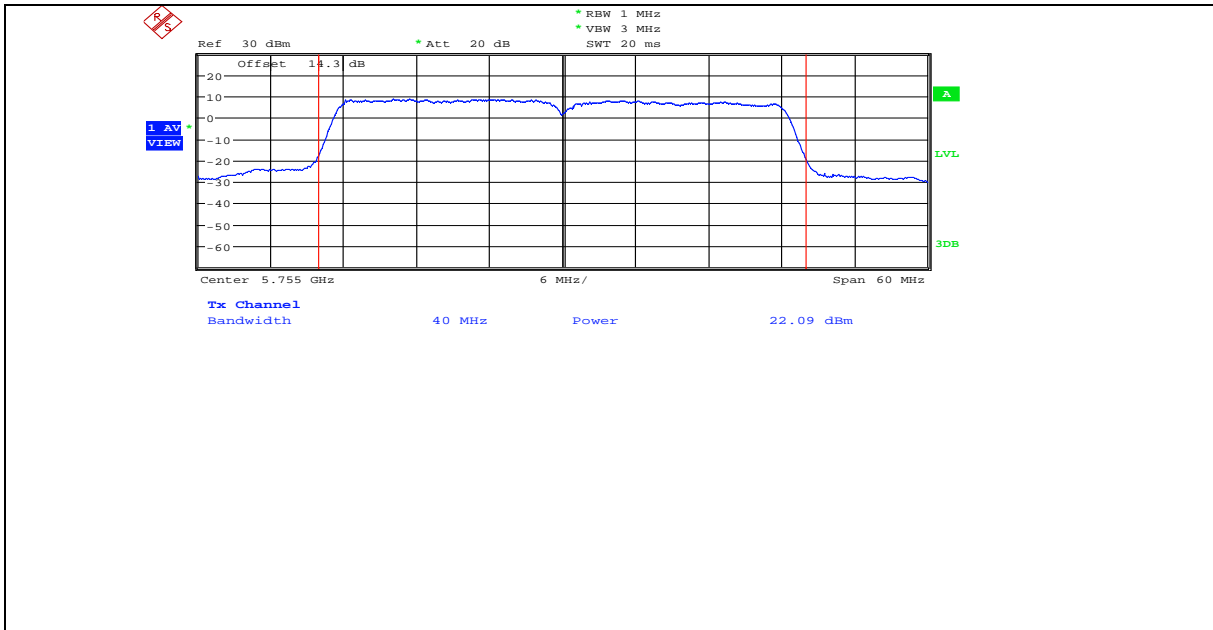

11N40MIMO\_ANT2\_5755

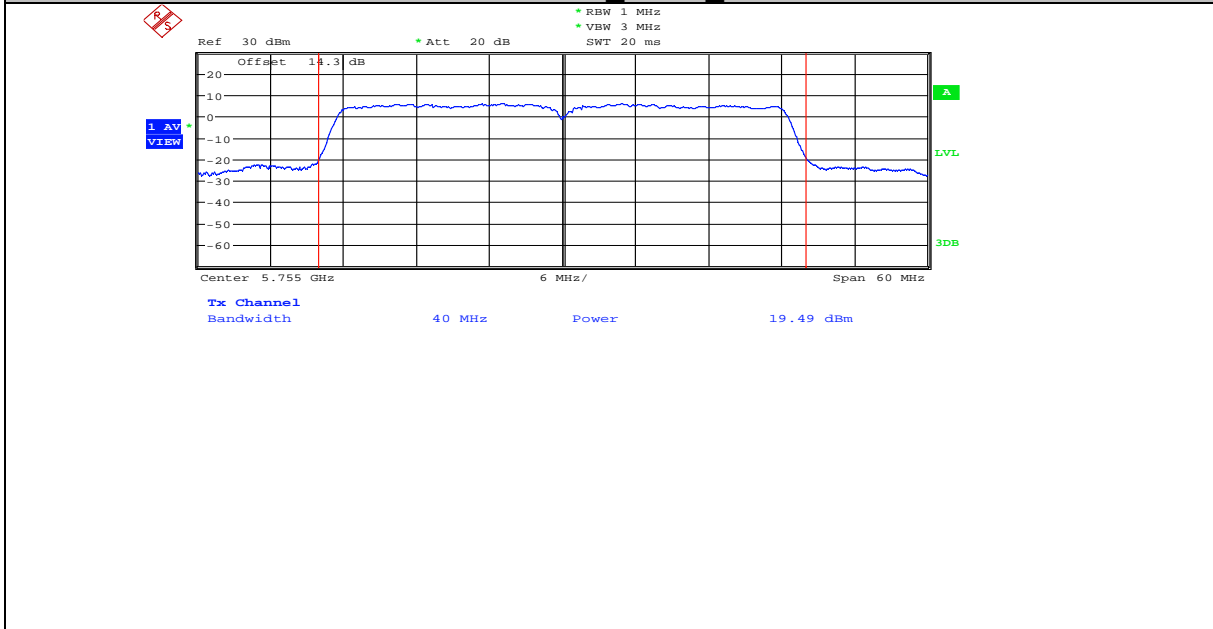

11N40MIMO\_ANT3\_5755

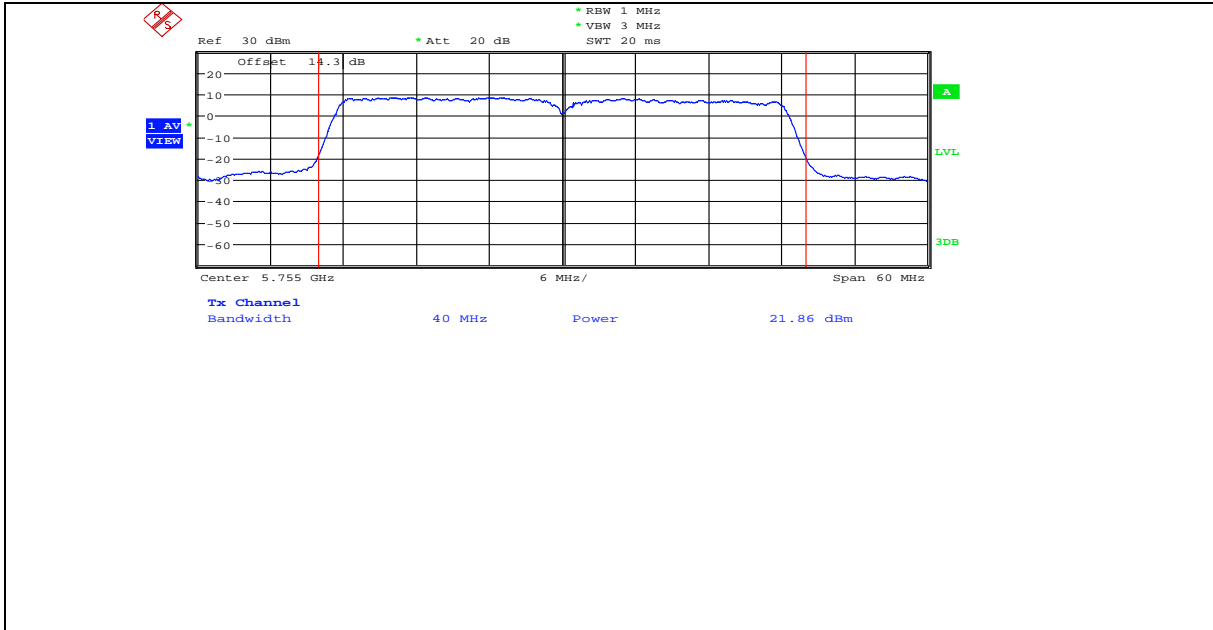

11N40MIMO\_ANT1\_5795

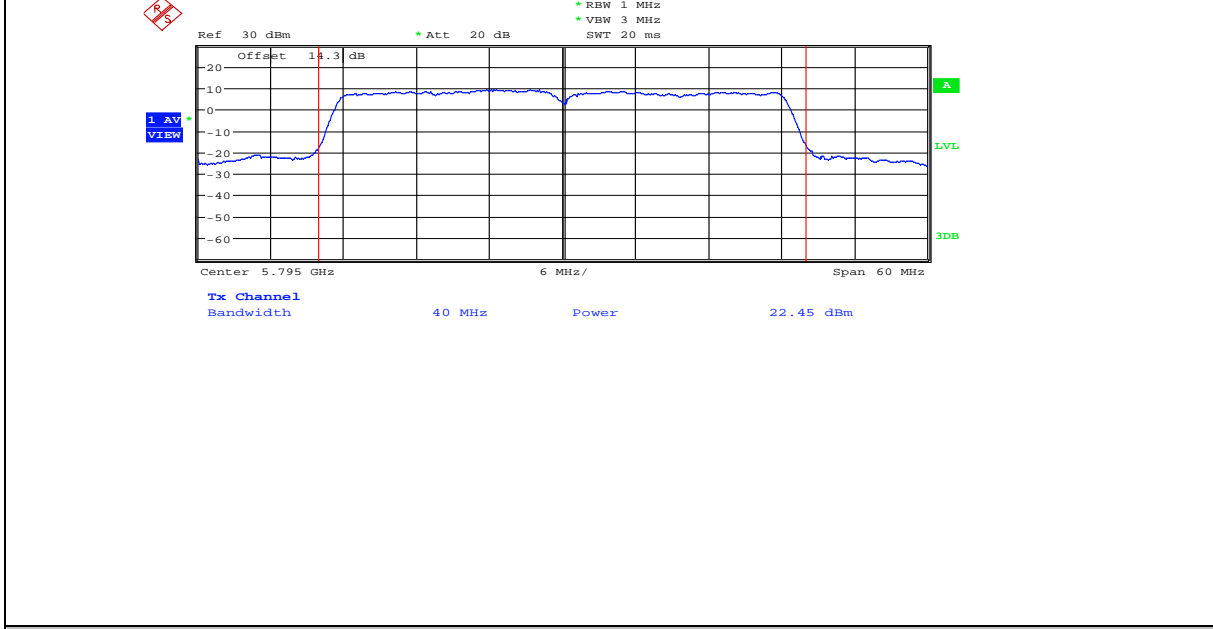

11N40MIMO\_ANT2\_5795

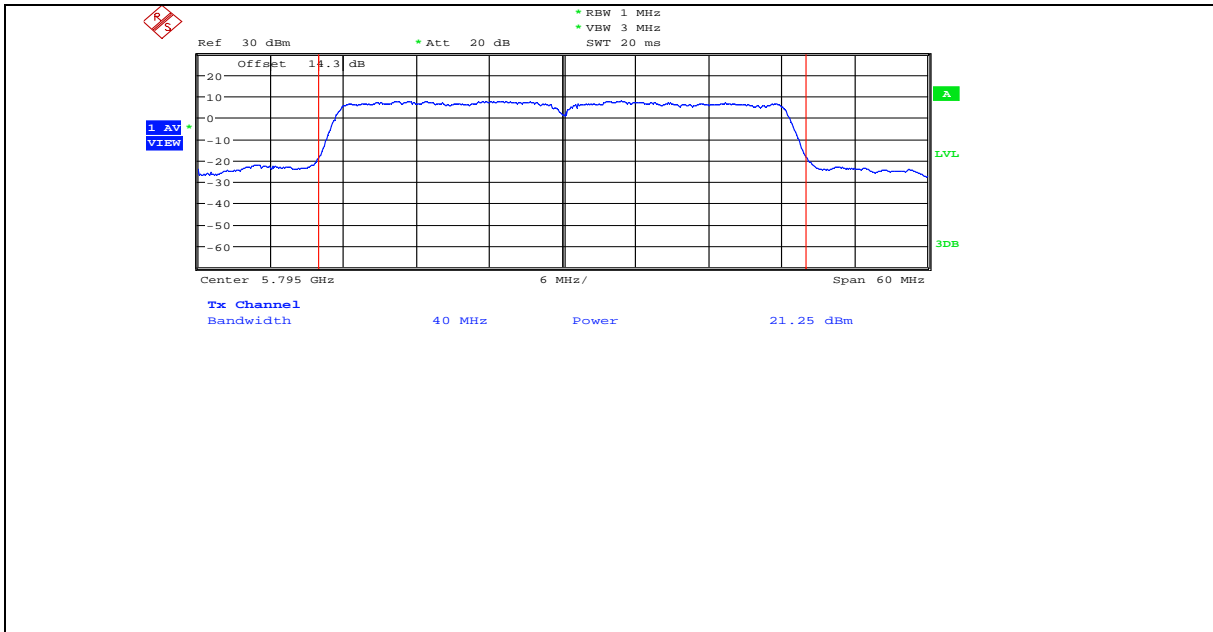

11N40MIMO\_ANT3\_5795

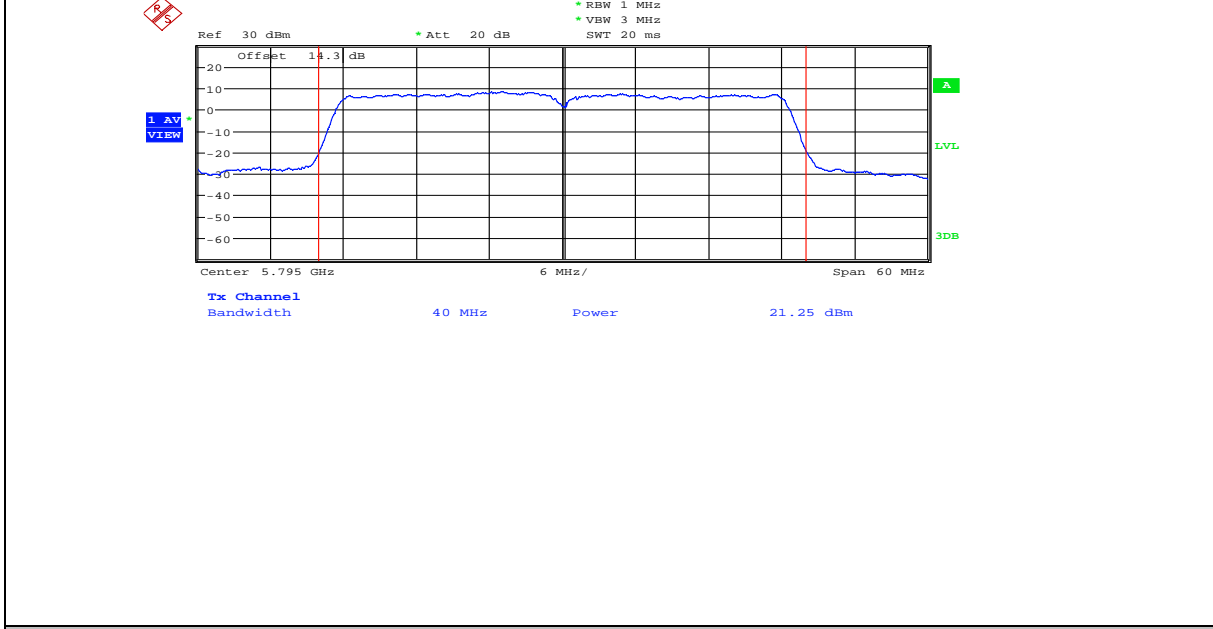

11AC20MIMO\_ANT1\_5180

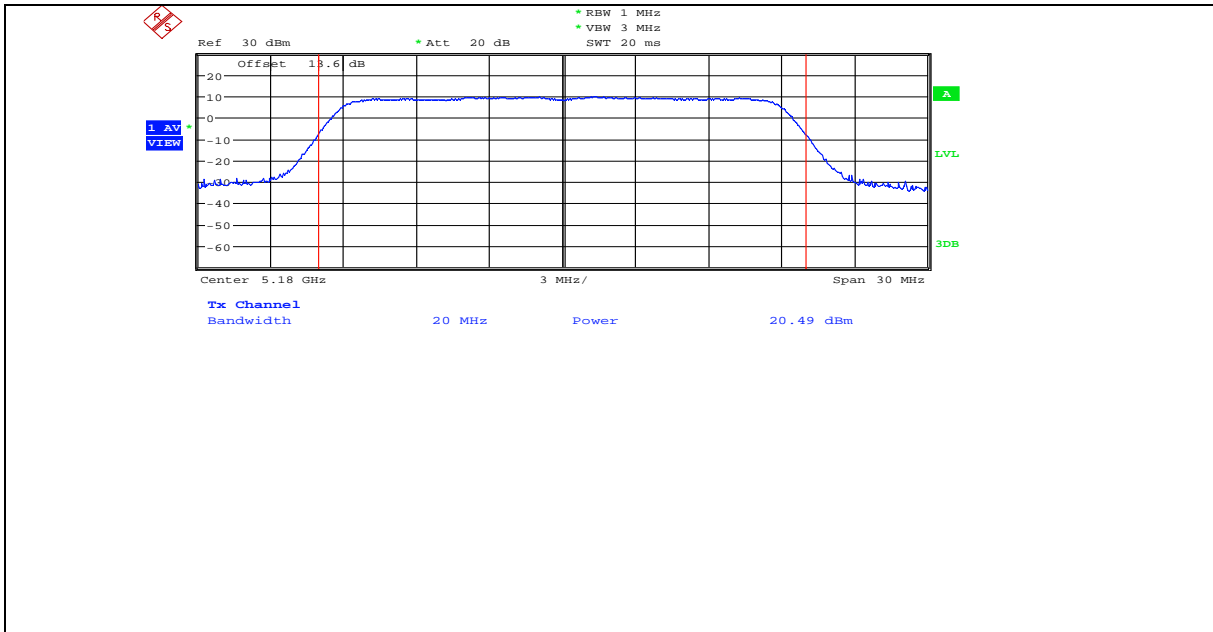

11AC20MIMO\_ANT2\_5180

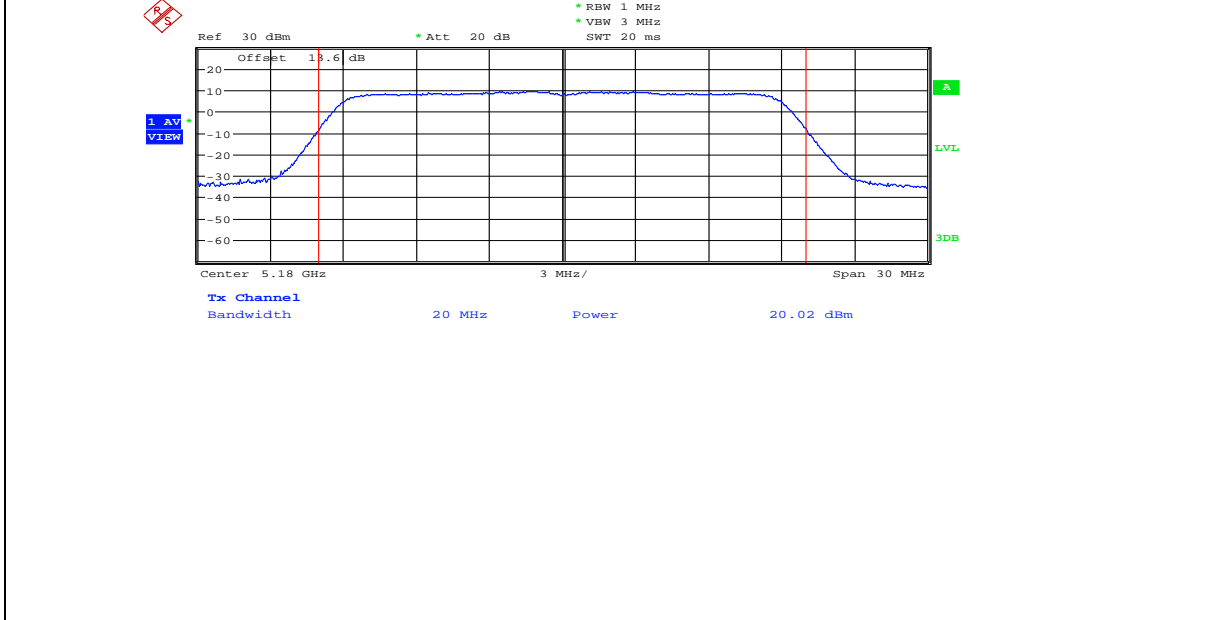

11AC20MIMO\_ANT3\_5180

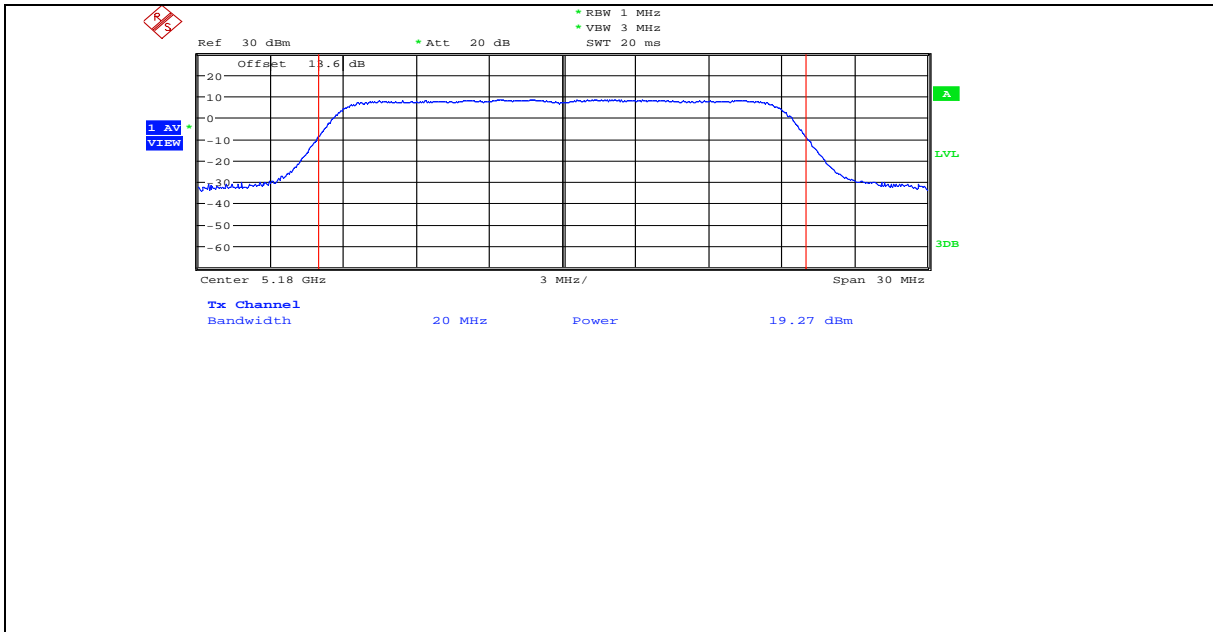

11AC20MIMO\_ANT1\_5200

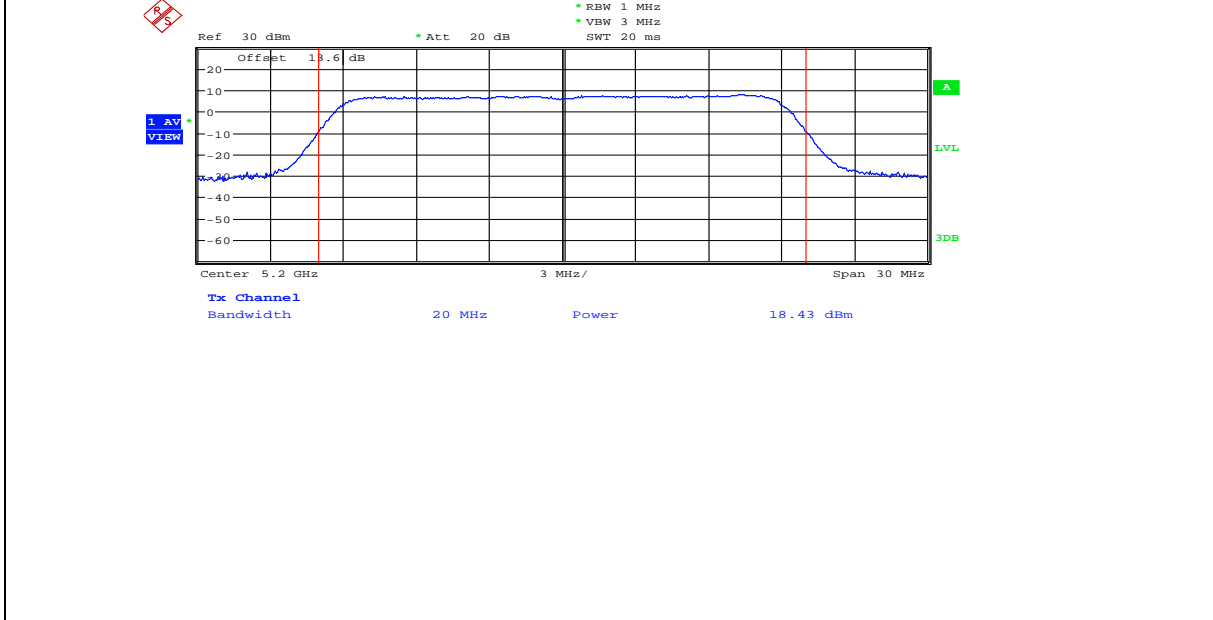

11AC20MIMO\_ANT2\_5200

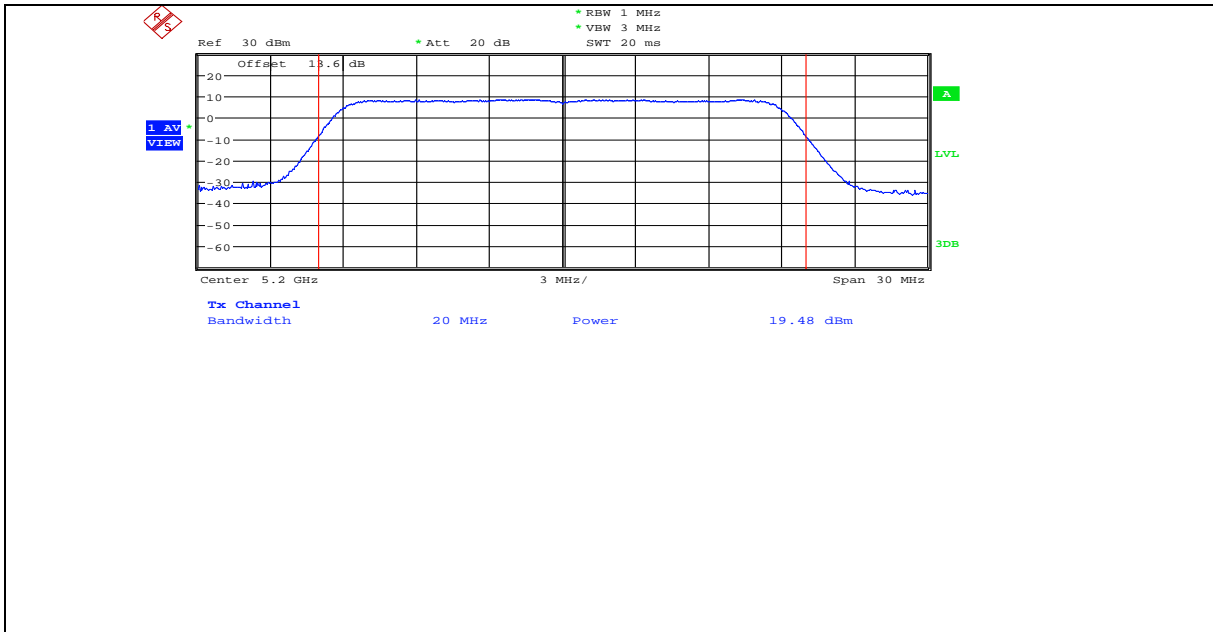

11AC20MIMO\_ANT3\_5200

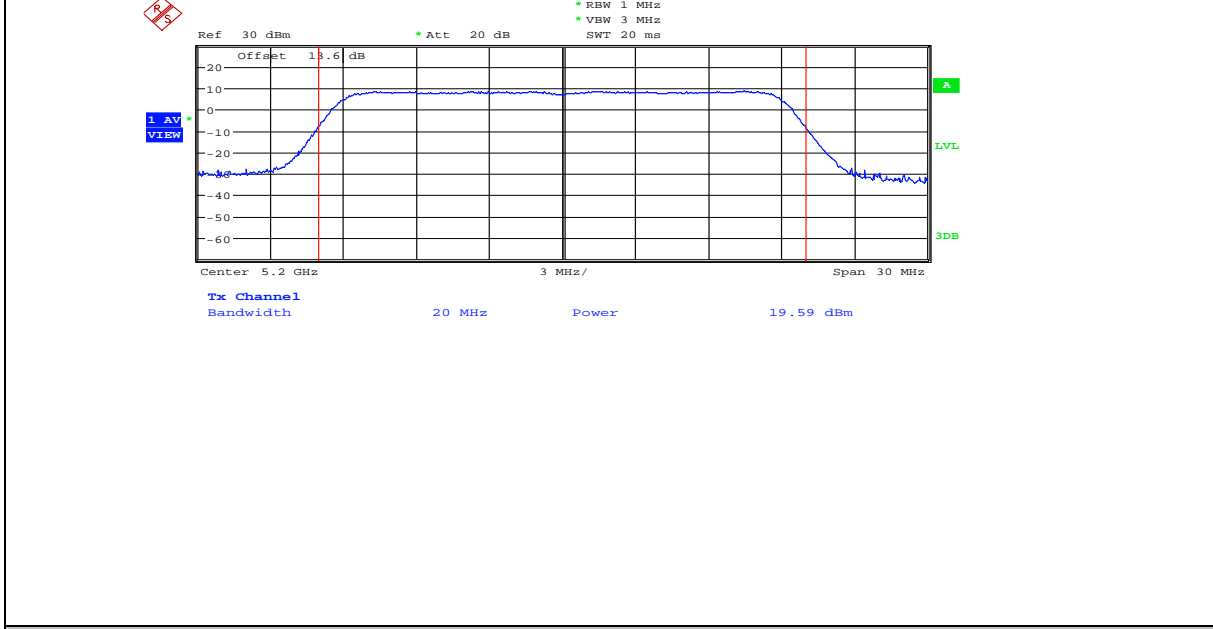

11AC20MIMO\_ANT1\_5240

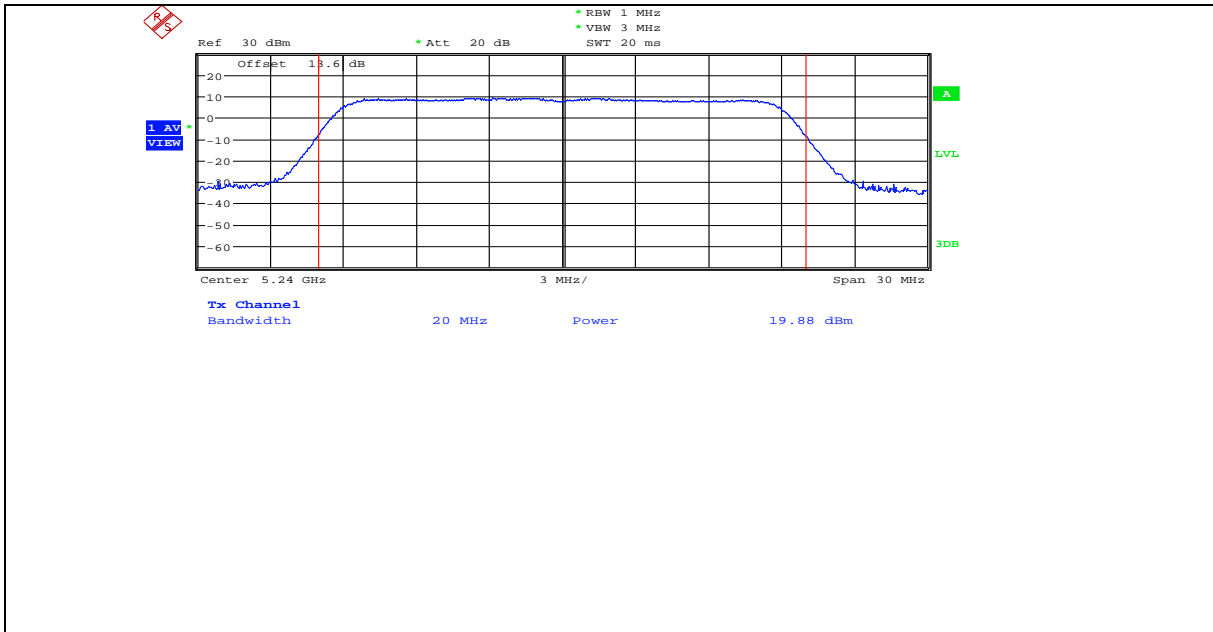

11AC20MIMO\_ANT2\_5240

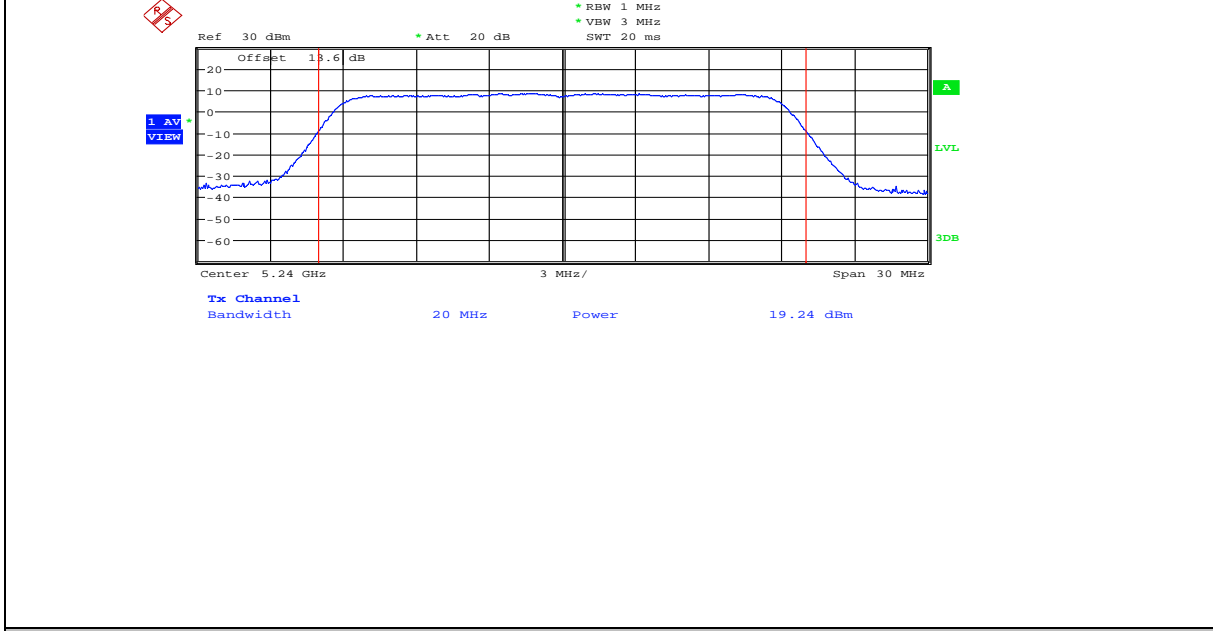

11AC20MIMO\_ANT3\_5240

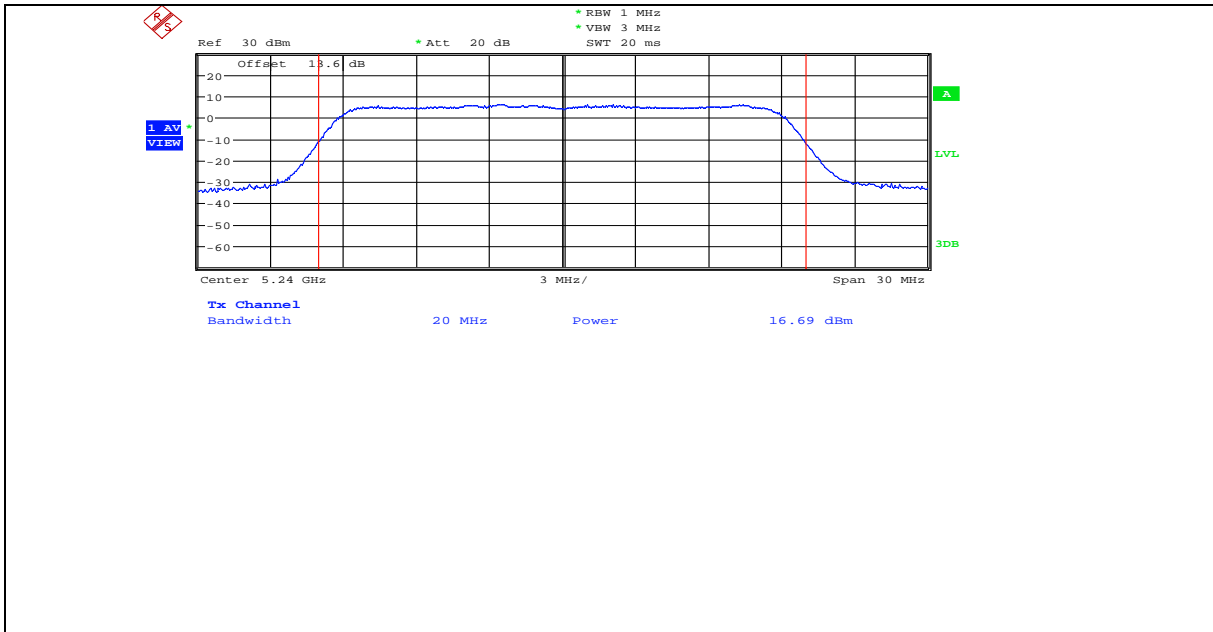

11AC20MIMO\_ANT1\_5745

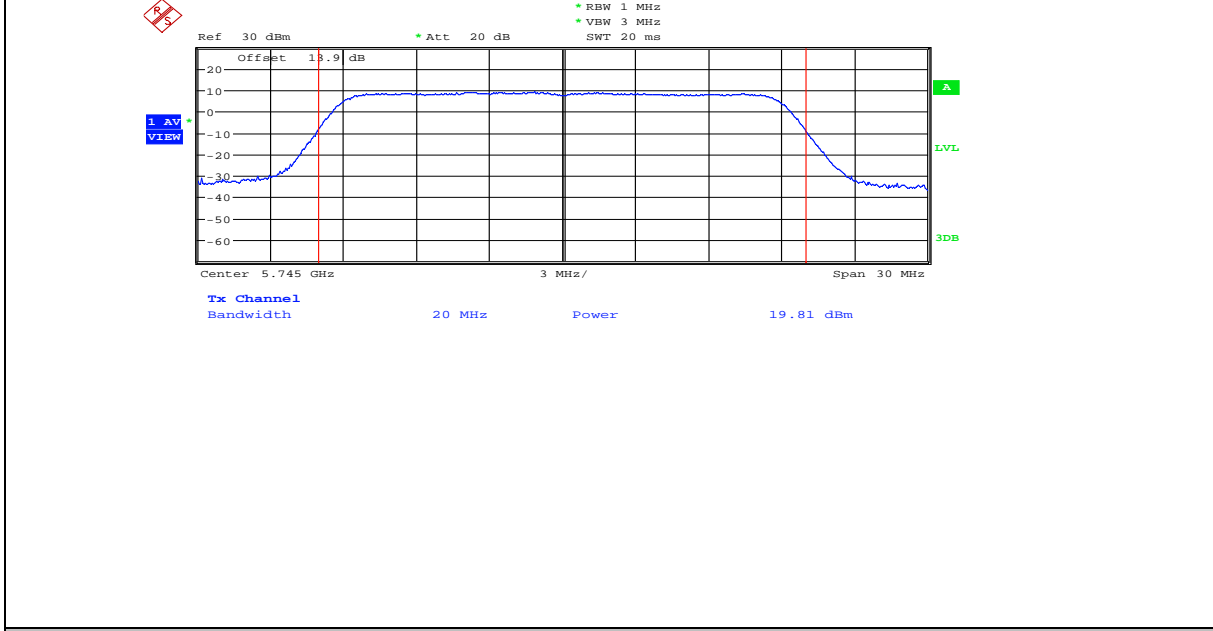

11AC20MIMO\_ANT2\_5745



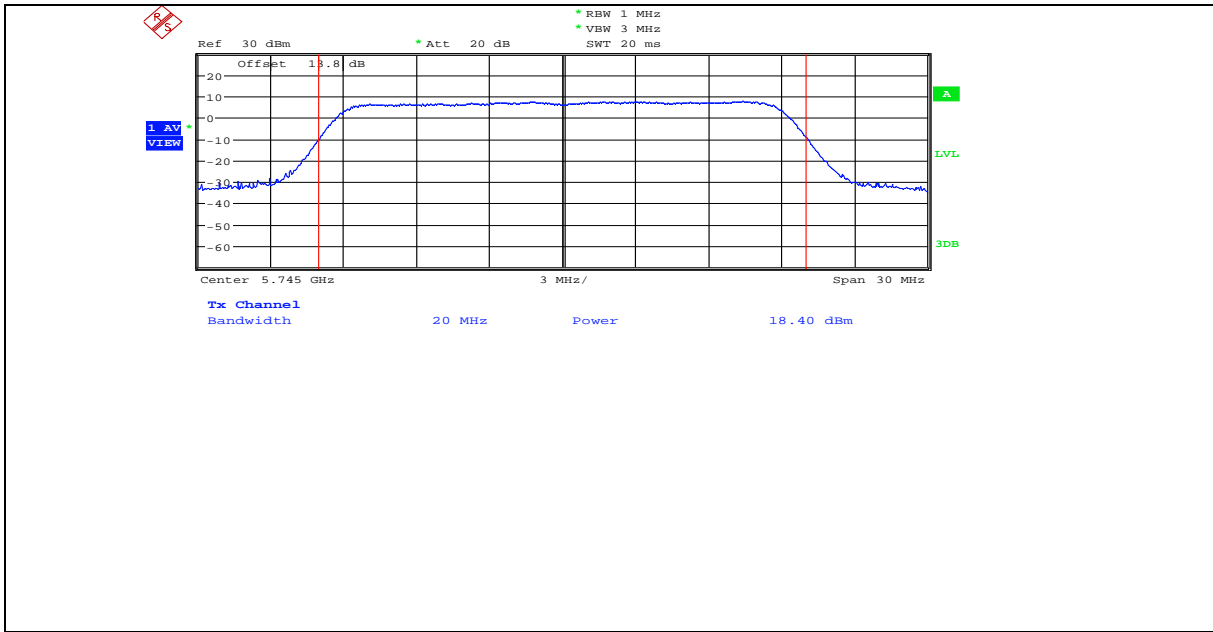

11AC20MIMO ANT3\_5745

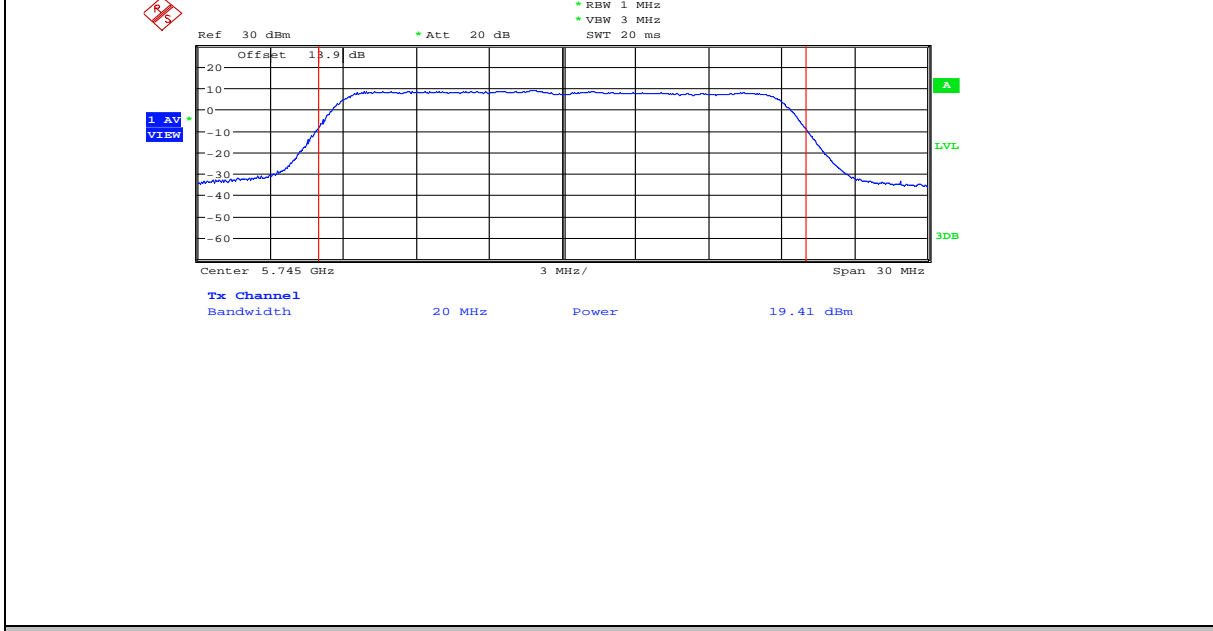

11AC20MIMO ANT1\_5785

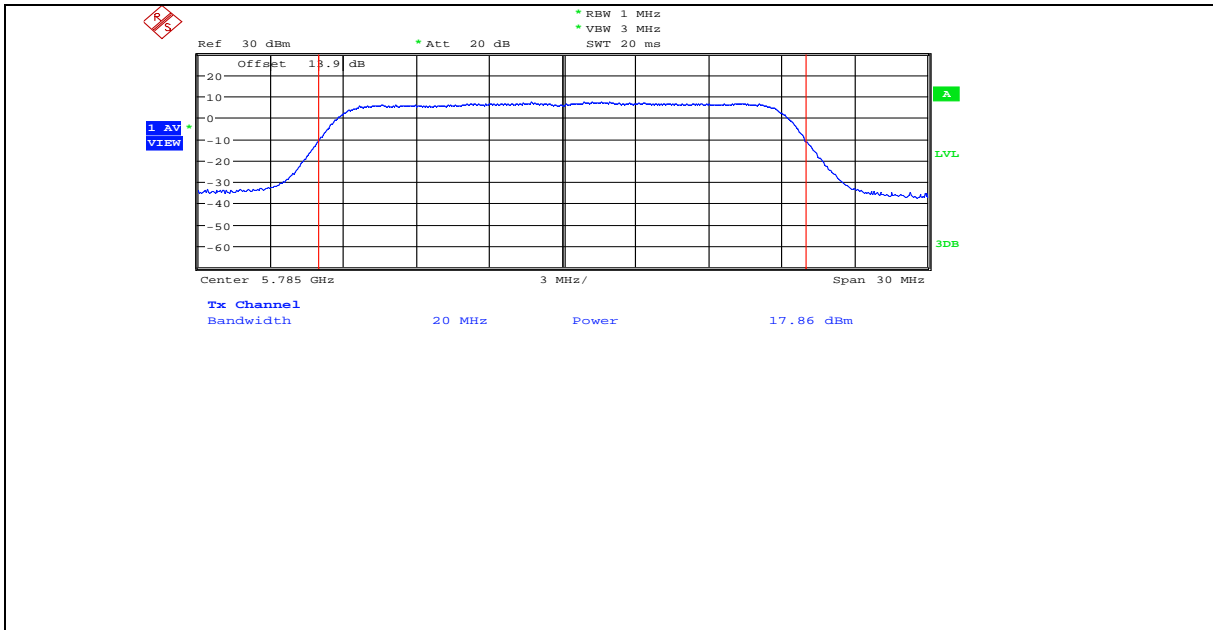

11AC20MIMO ANT2\_5785

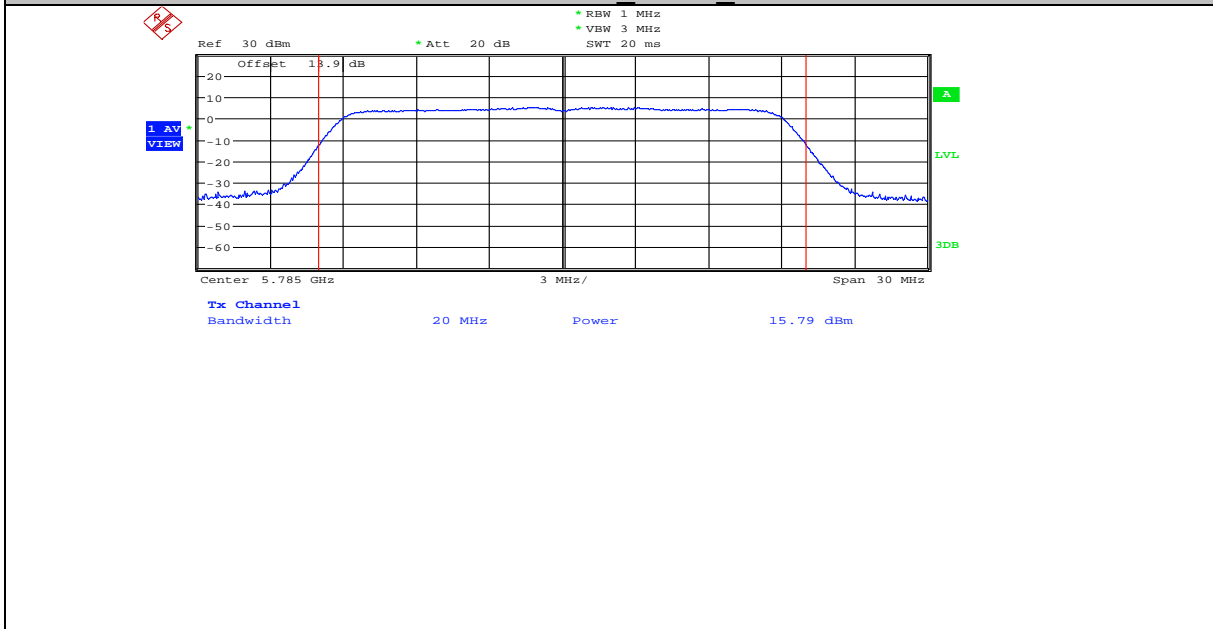

11AC20MIMO ANT3\_5785

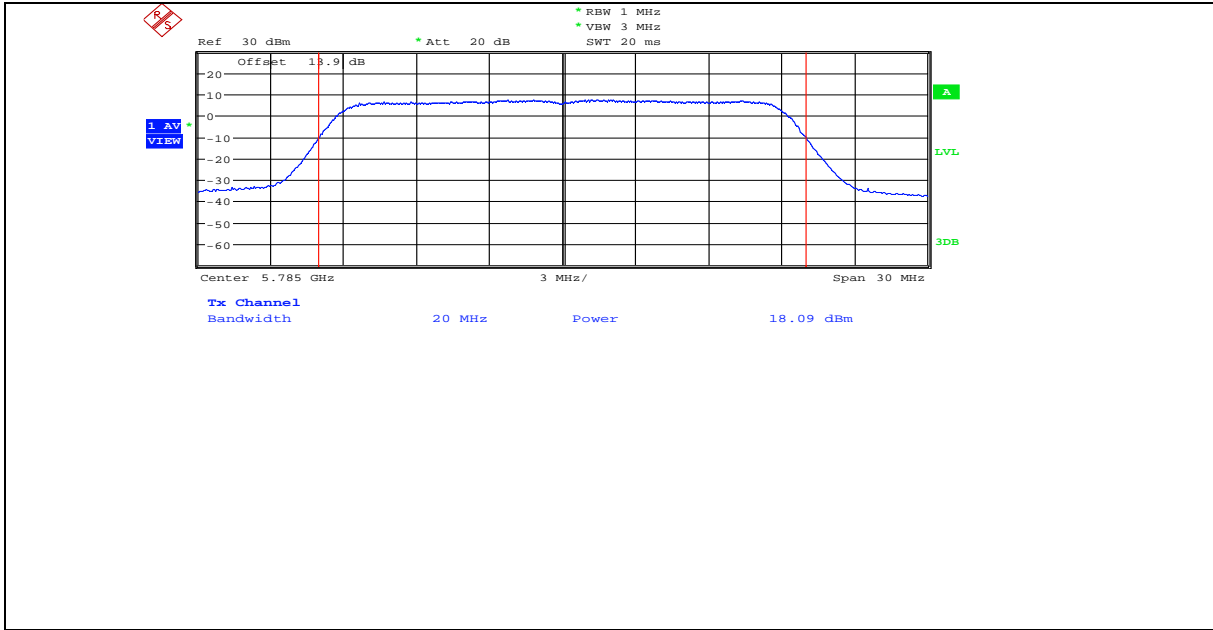

11AC20MIMO ANT1\_5825

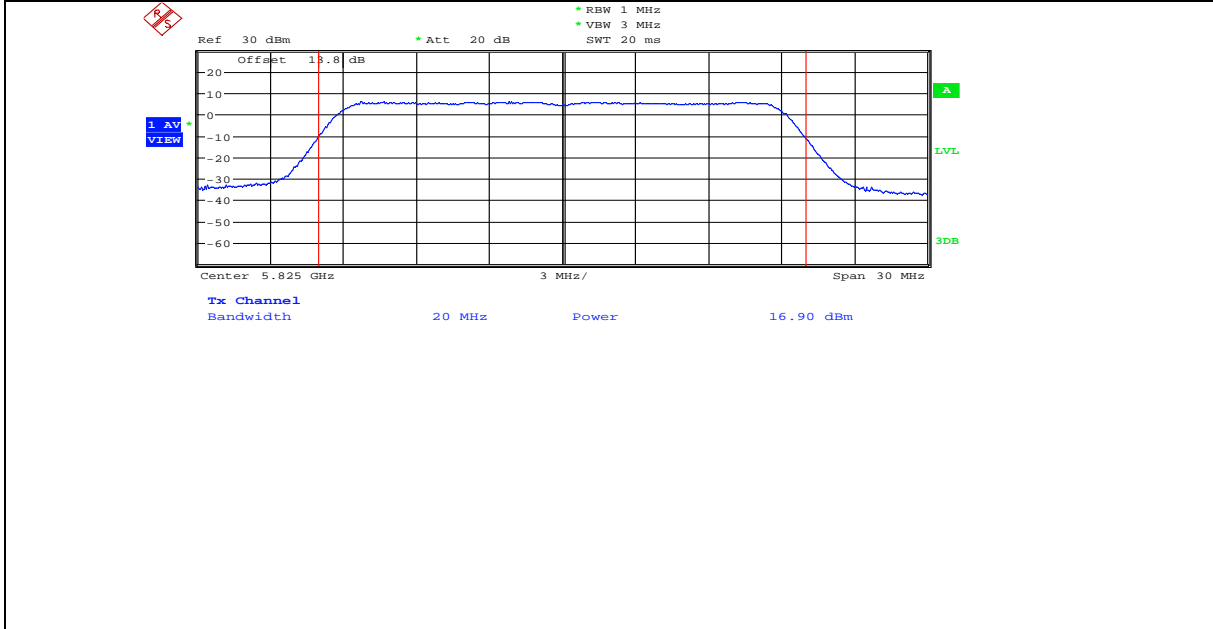

11AC20MIMO ANT2\_5825

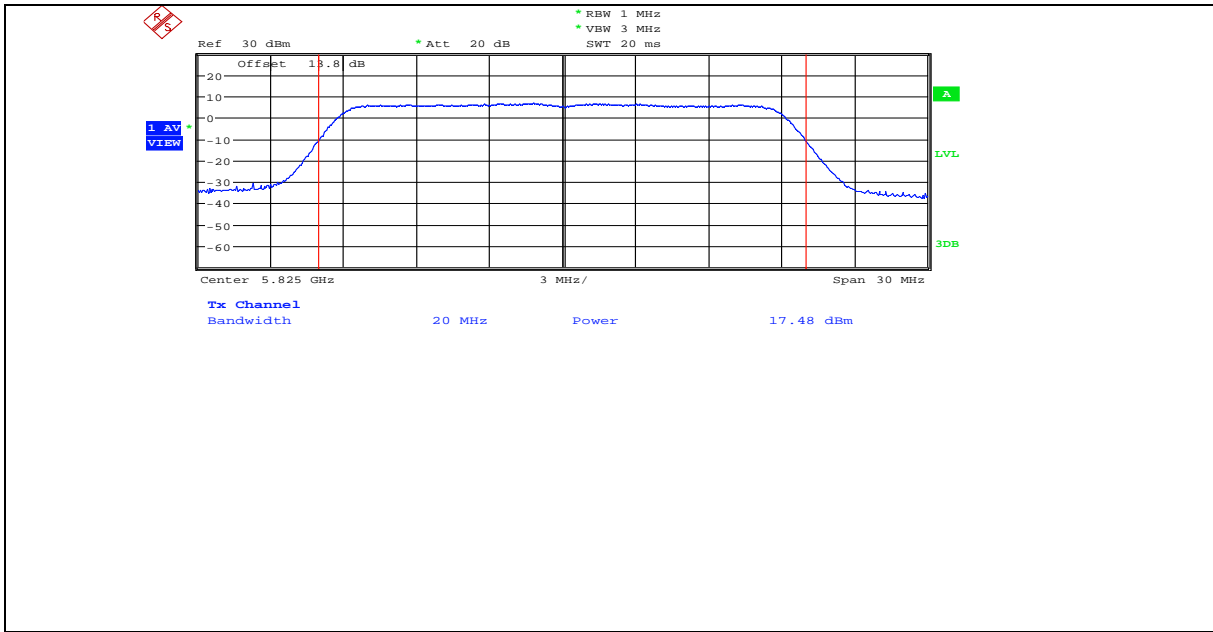

11AC20MIMO\_ANT3\_5825

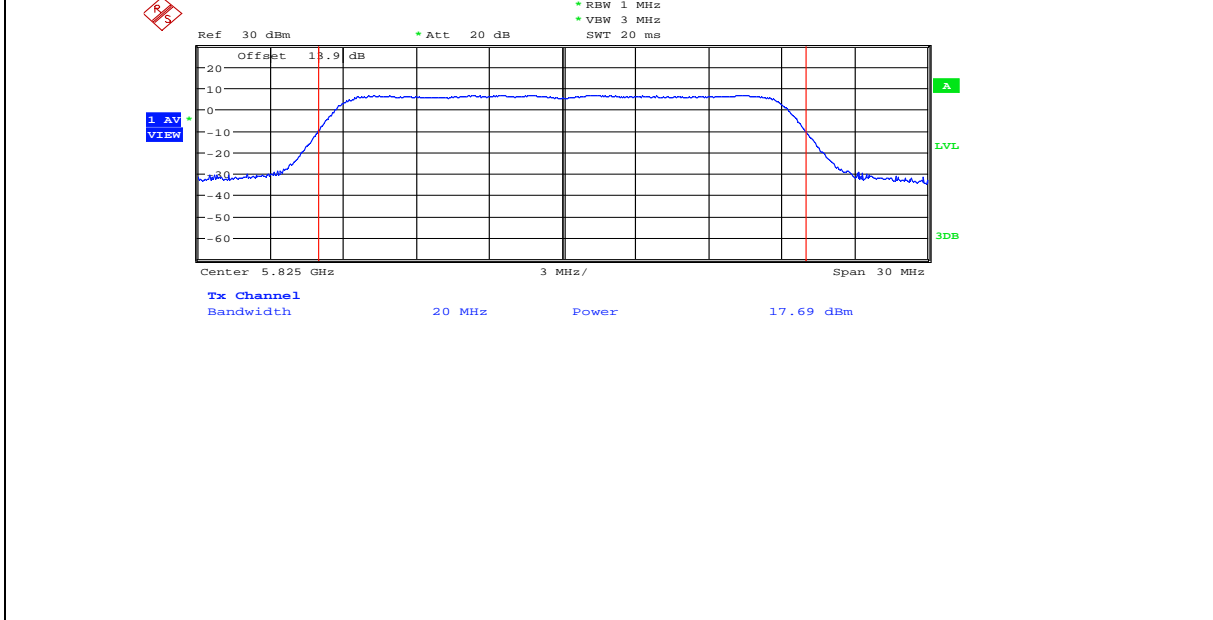

11AC40MIMO\_ANT1\_5190

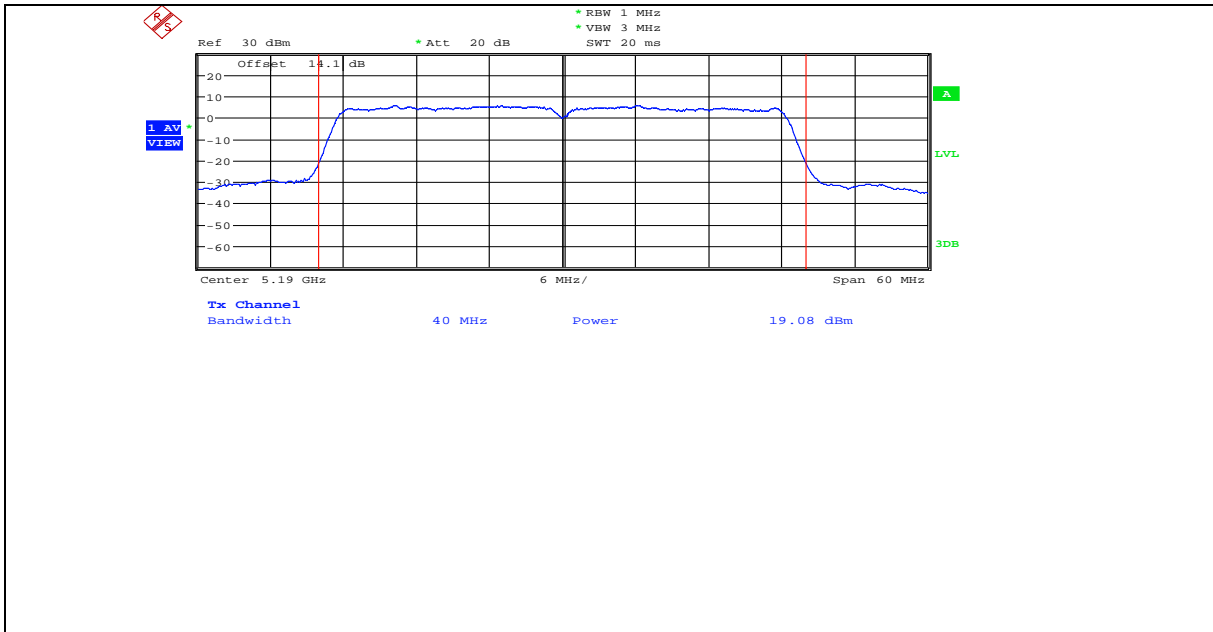

11AC40MIMO\_ANT2\_5190

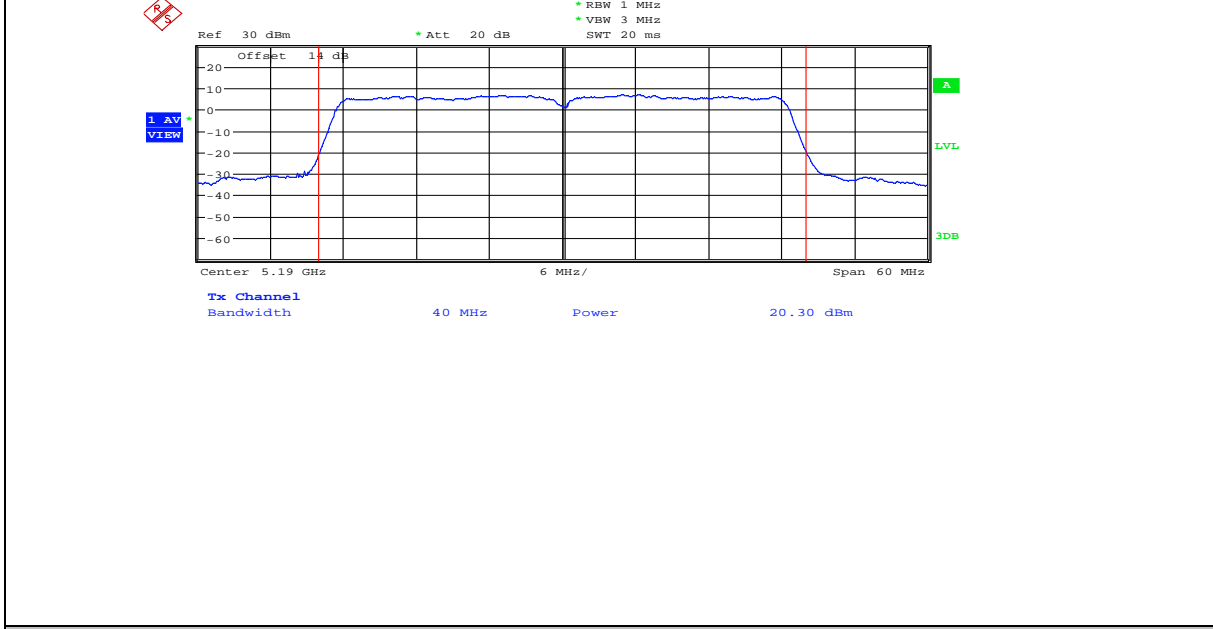

11AC40MIMO\_ANT3\_5190

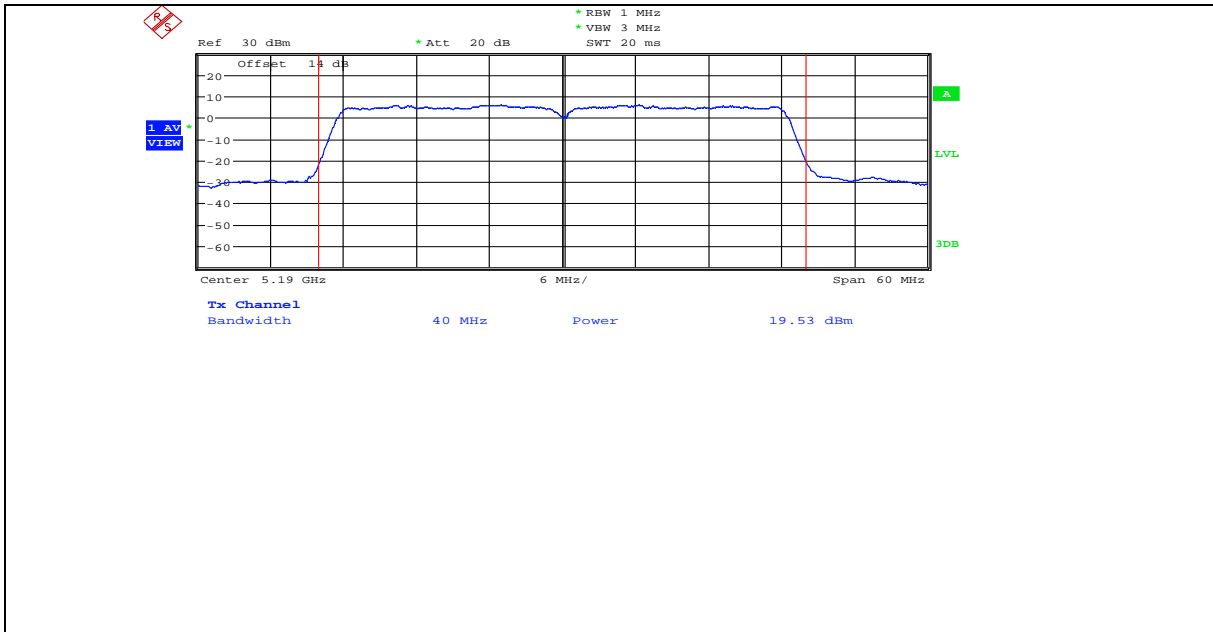

11AC40MIMO\_ANT1\_5230

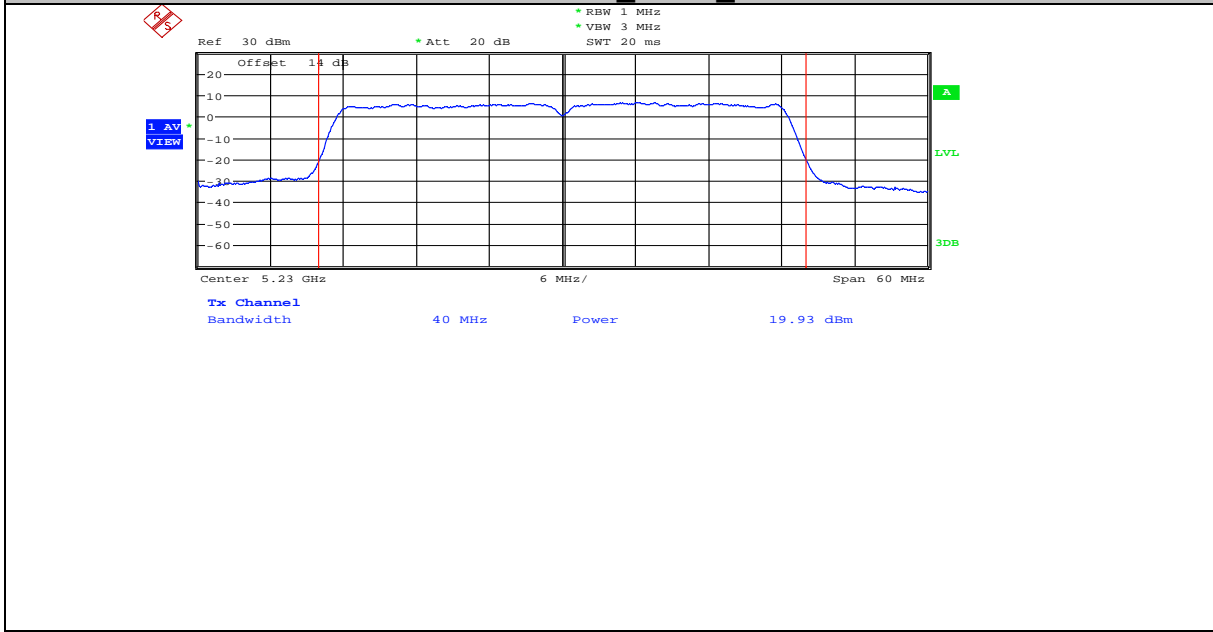

11AC40MIMO\_ANT2\_5230

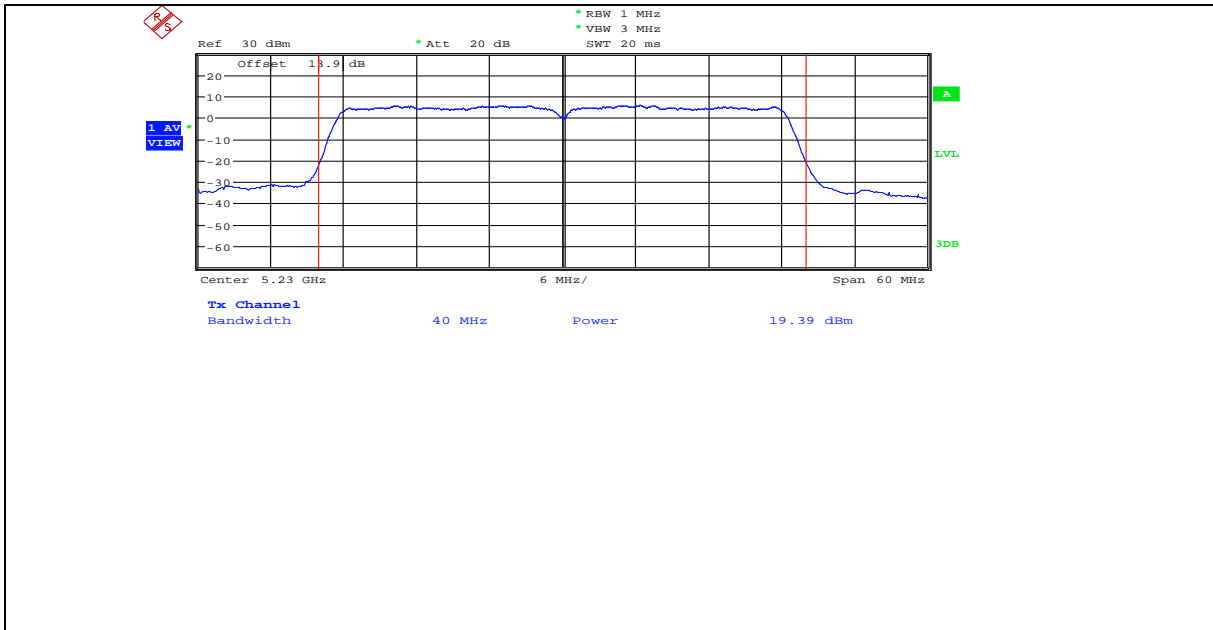

11AC40MIMO ANT3\_5230

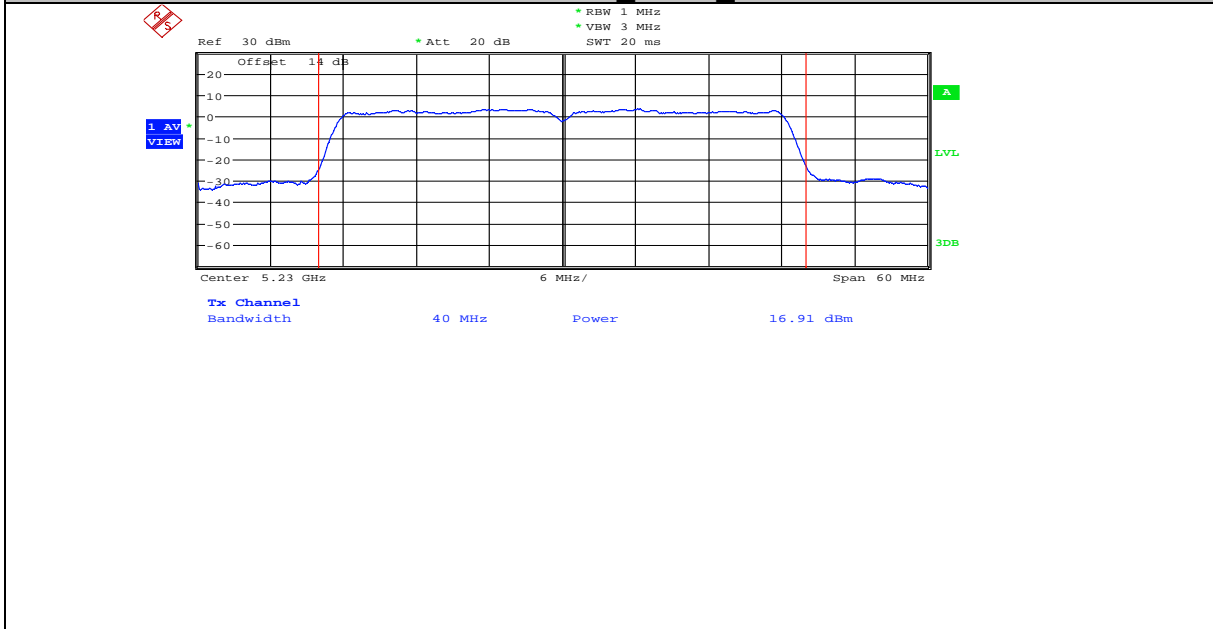

11AC40MIMO ANT1\_5755

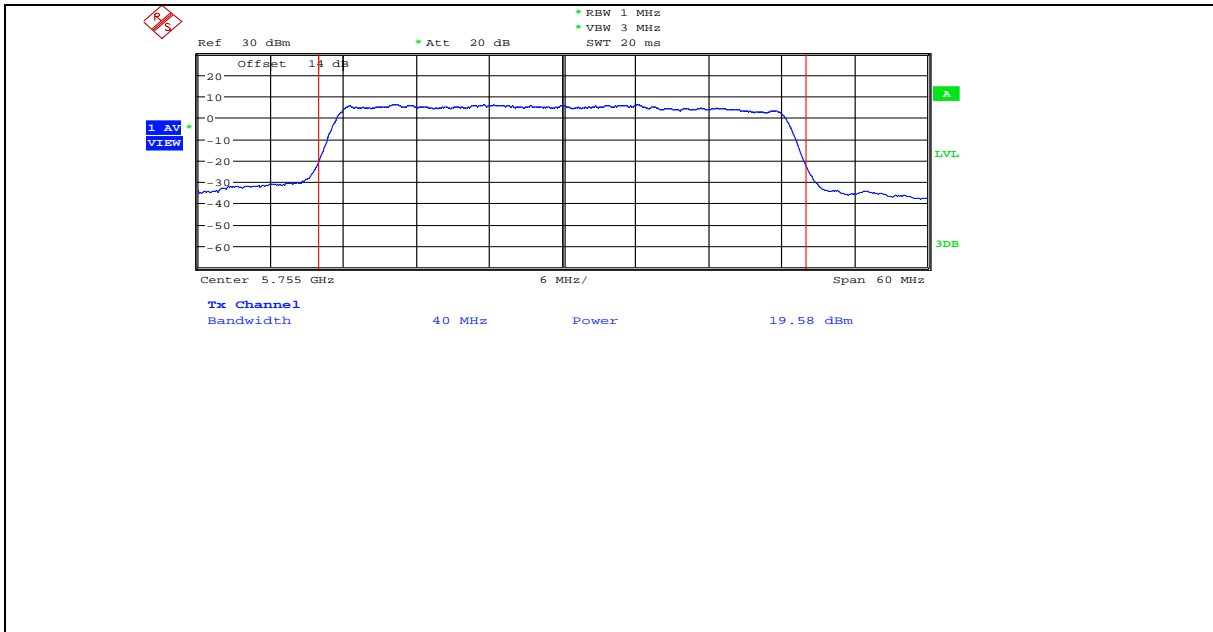

11AC40MIMO\_ANT2\_5755

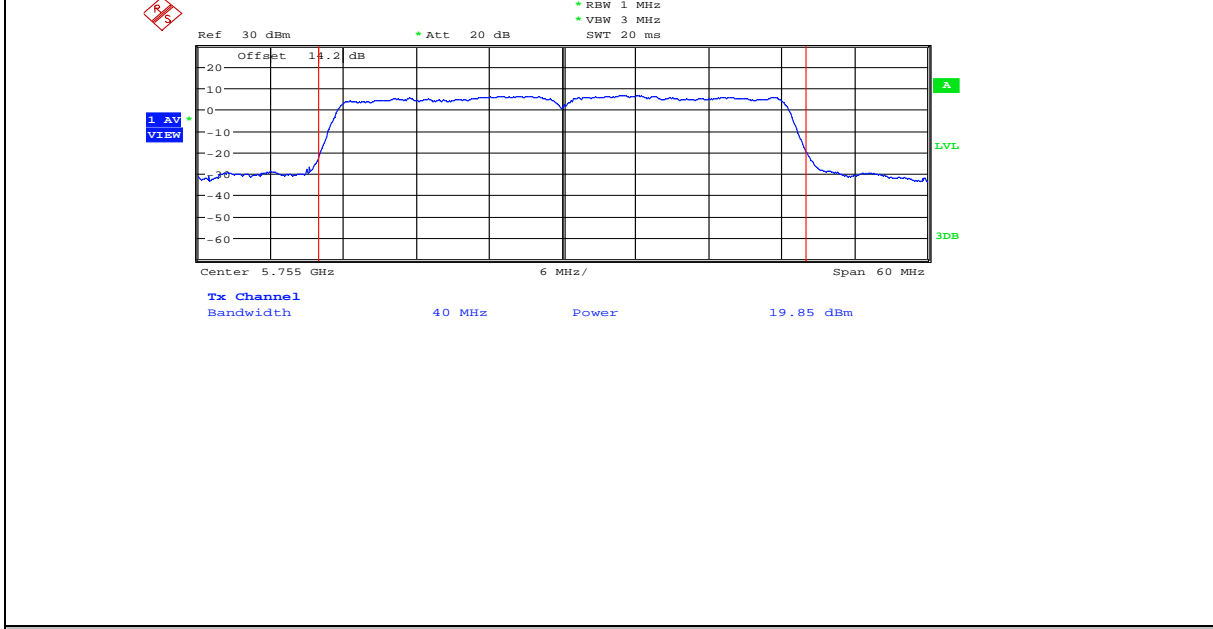

11AC40MIMO\_ANT3\_5755



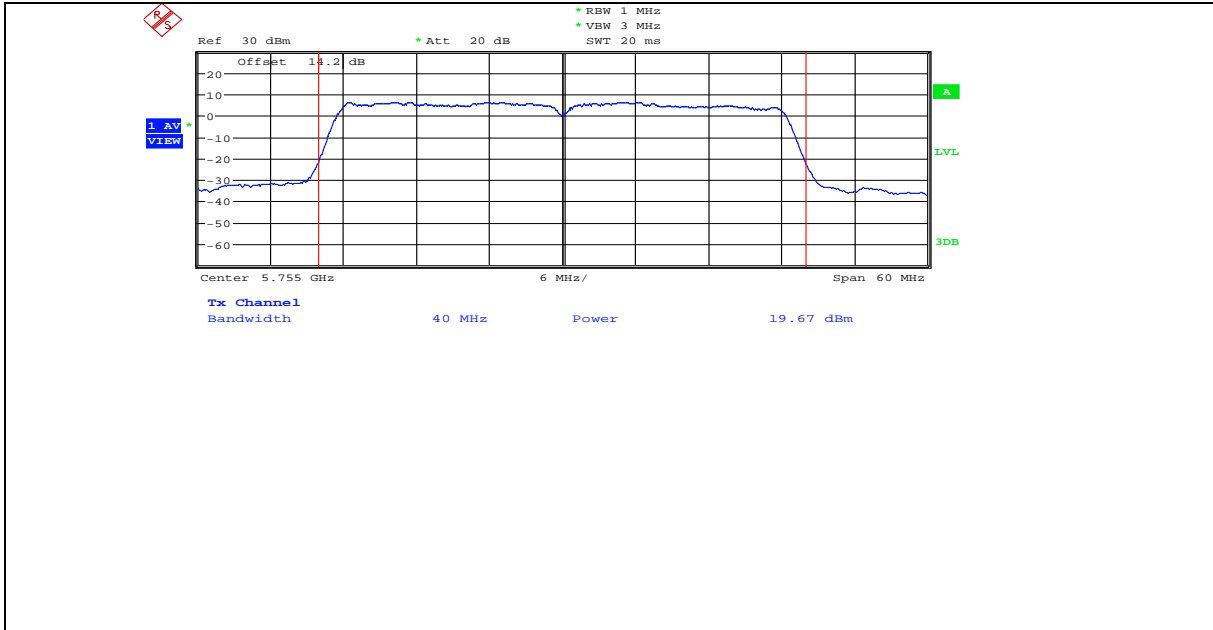

11AC40MIMO\_ANT1\_5795

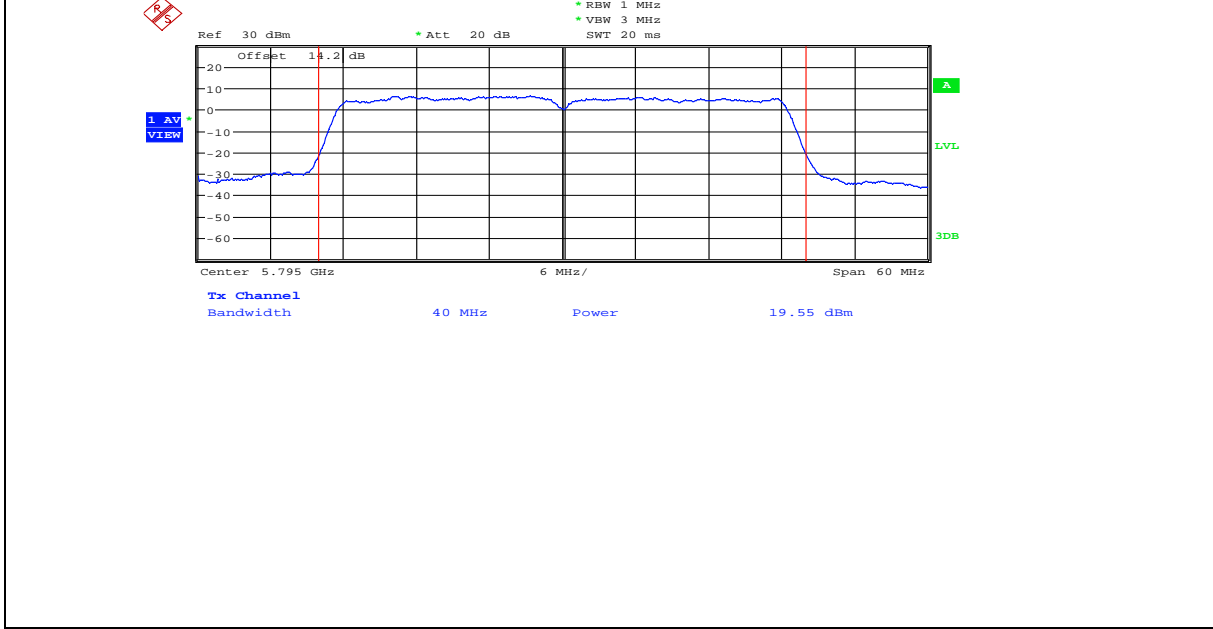

11AC40MIMO\_ANT2\_5795

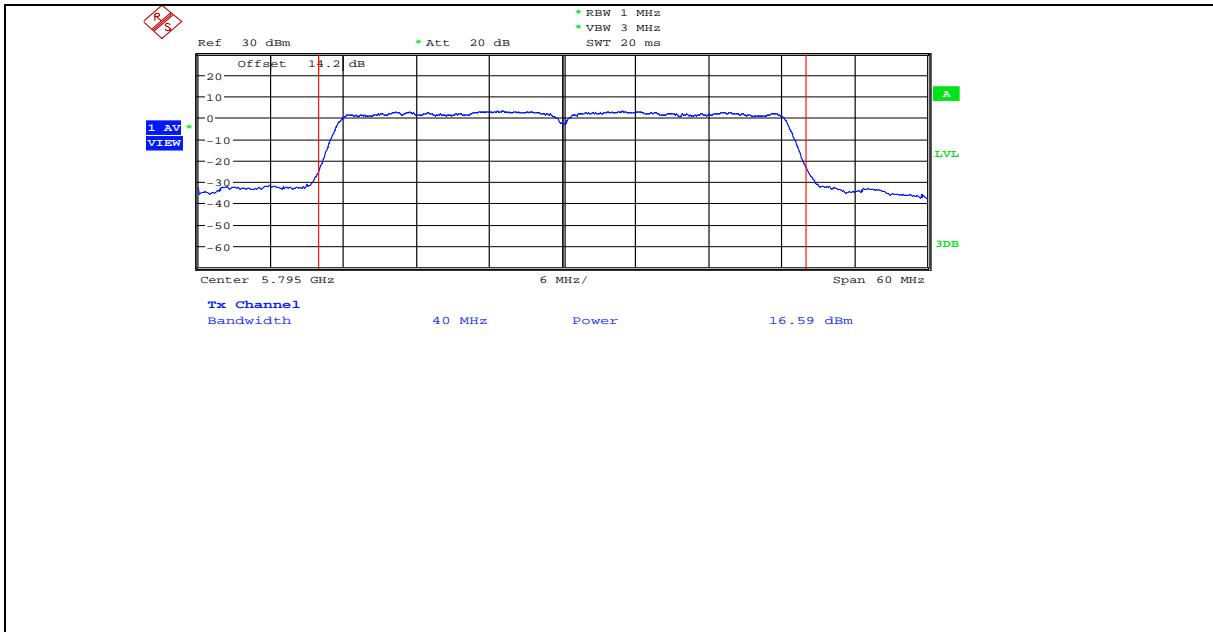

11AC40MIMO\_ANT3\_5795

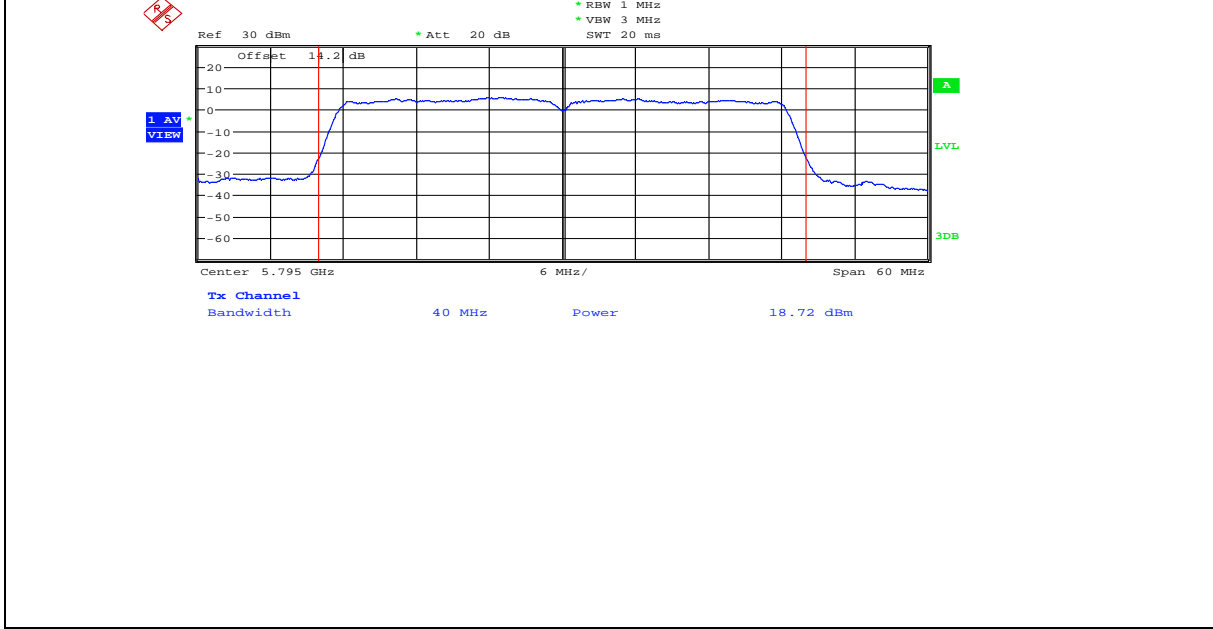

11AC80MIMO\_ANT1\_5210

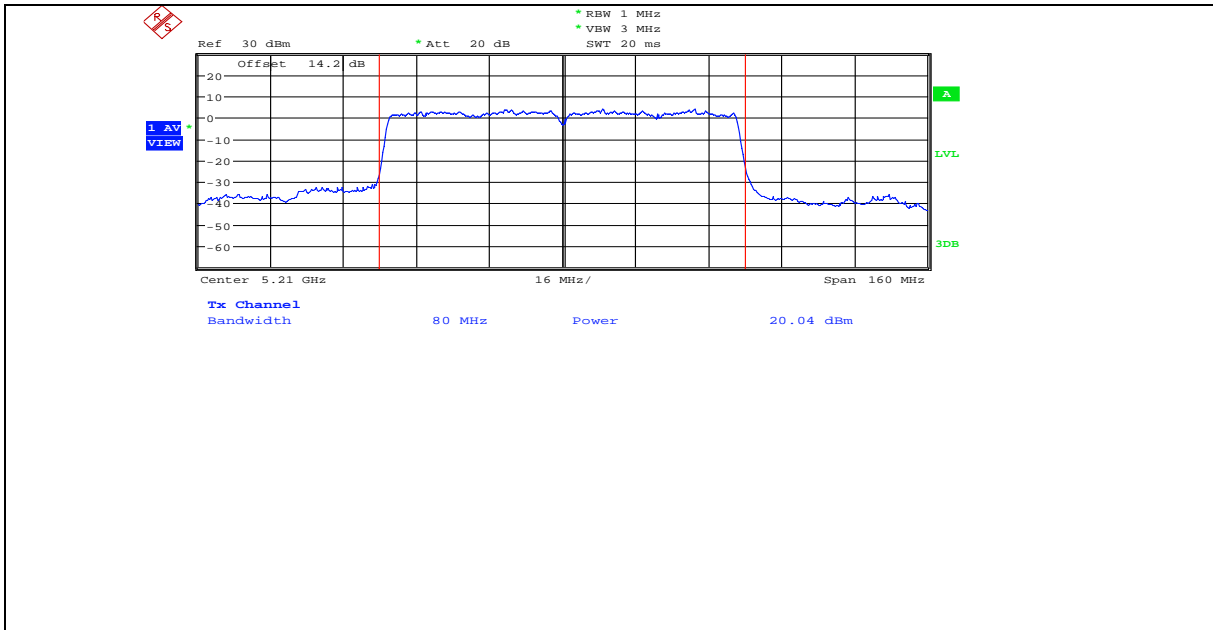

11AC80MIMO ANT2\_5210

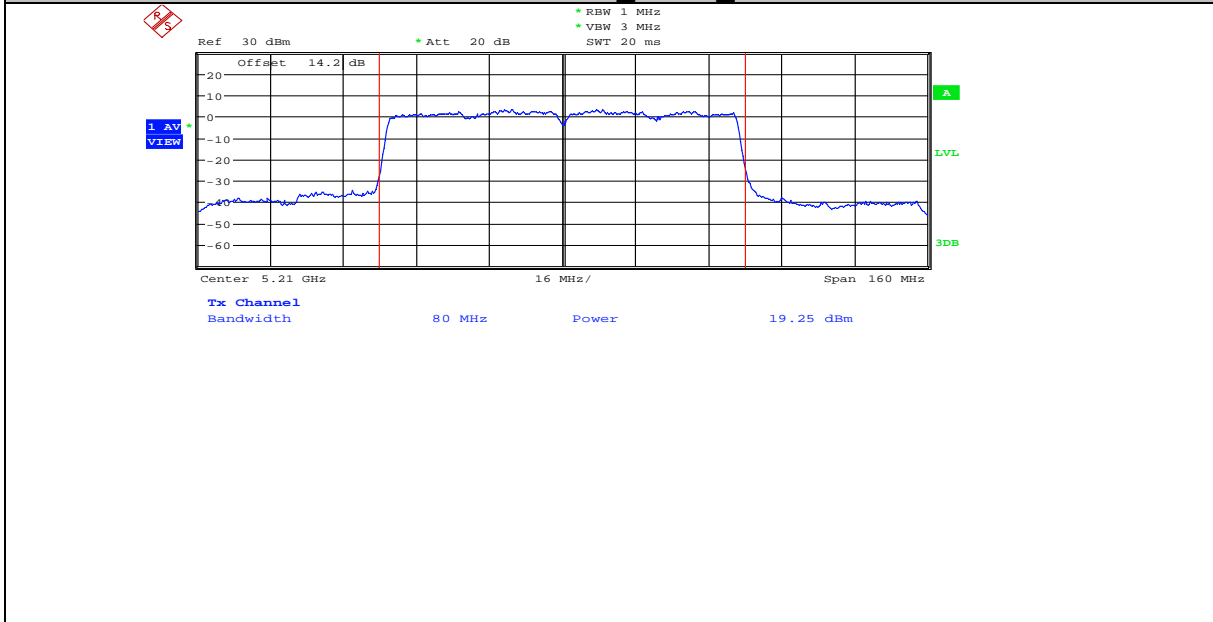

11AC80MIMO ANT3\_5210

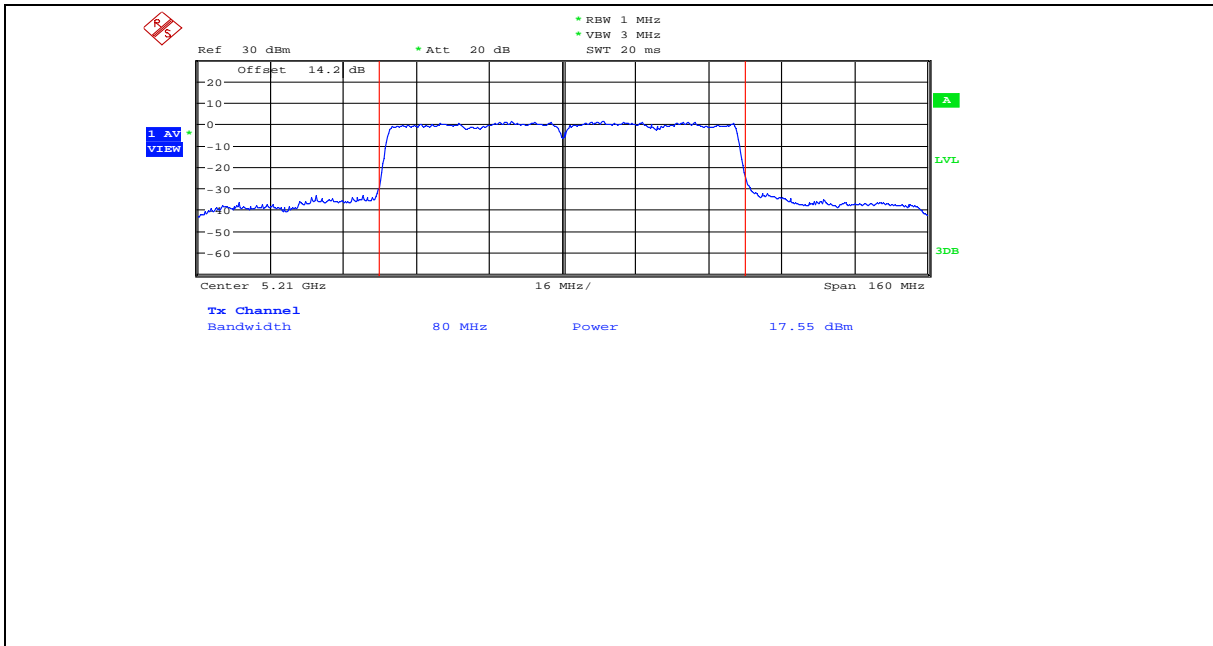

11AC80MIMO ANT1\_5775

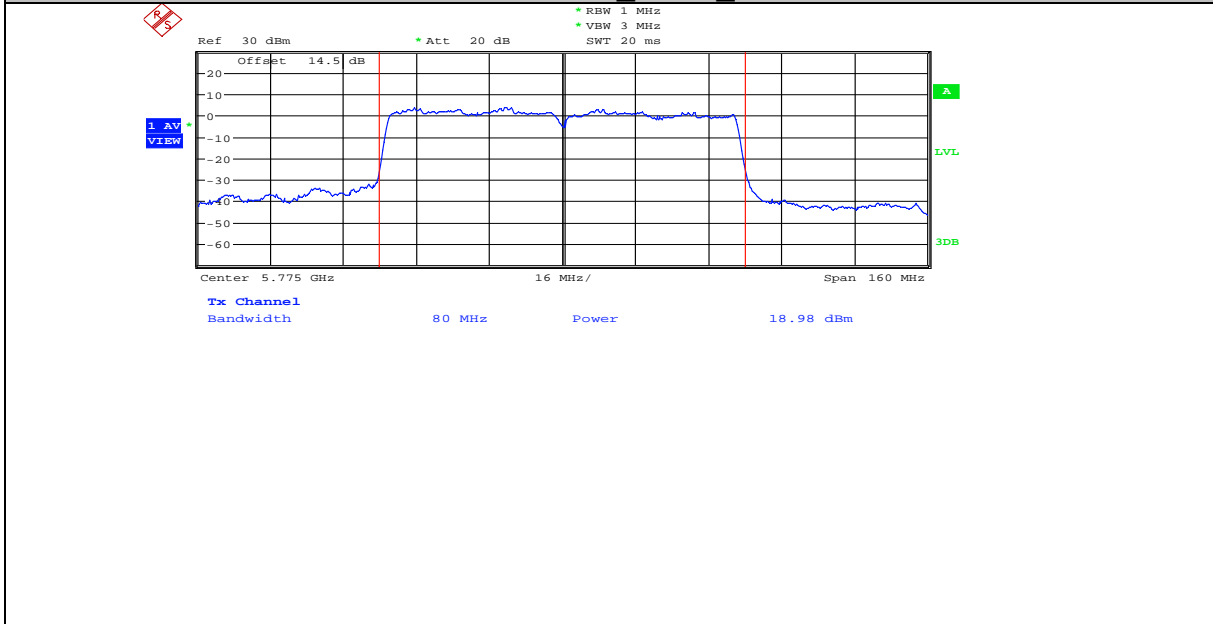

11AC80MIMO ANT2\_5775

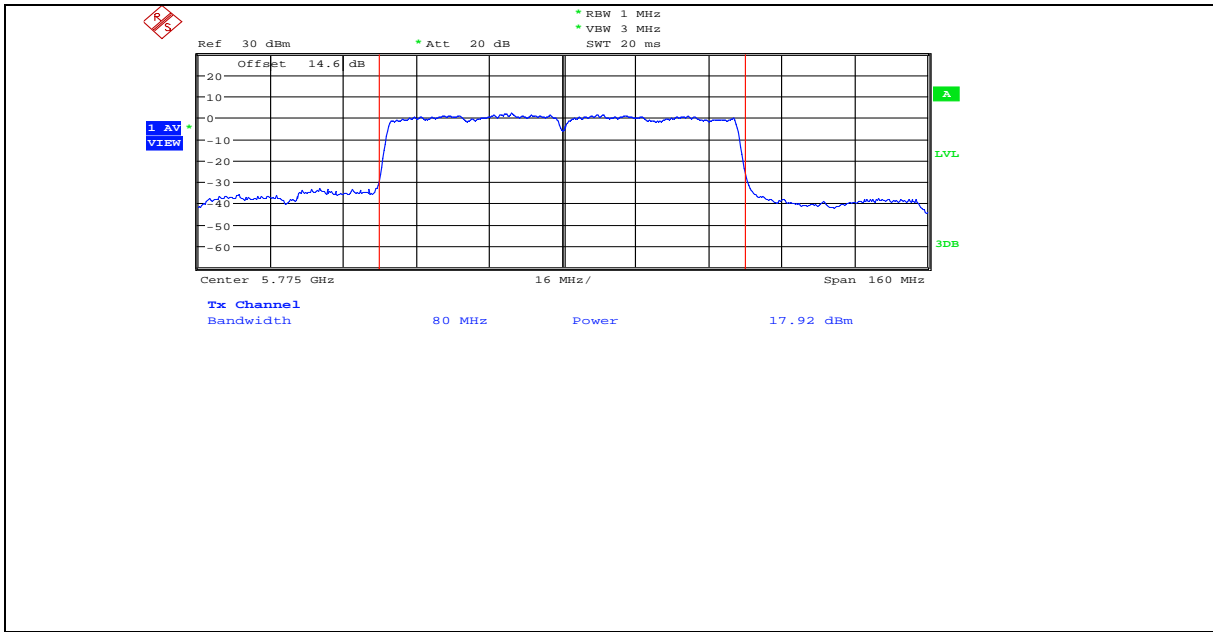

11AC80MIMO ANT3\_5775

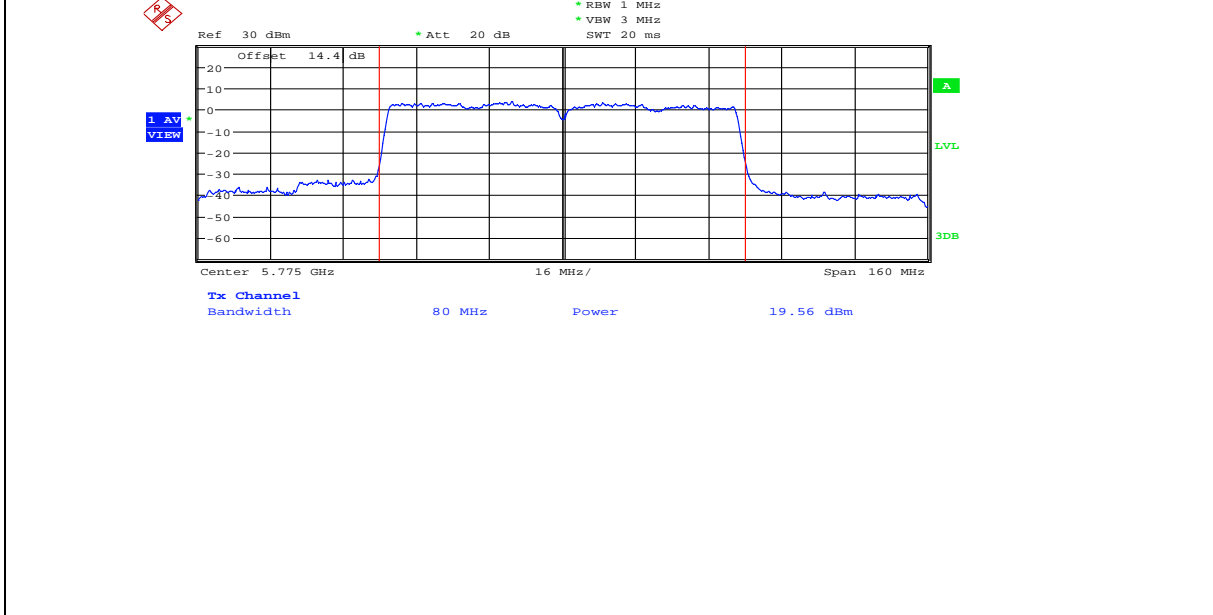

11ASISO\_ANT1\_5180

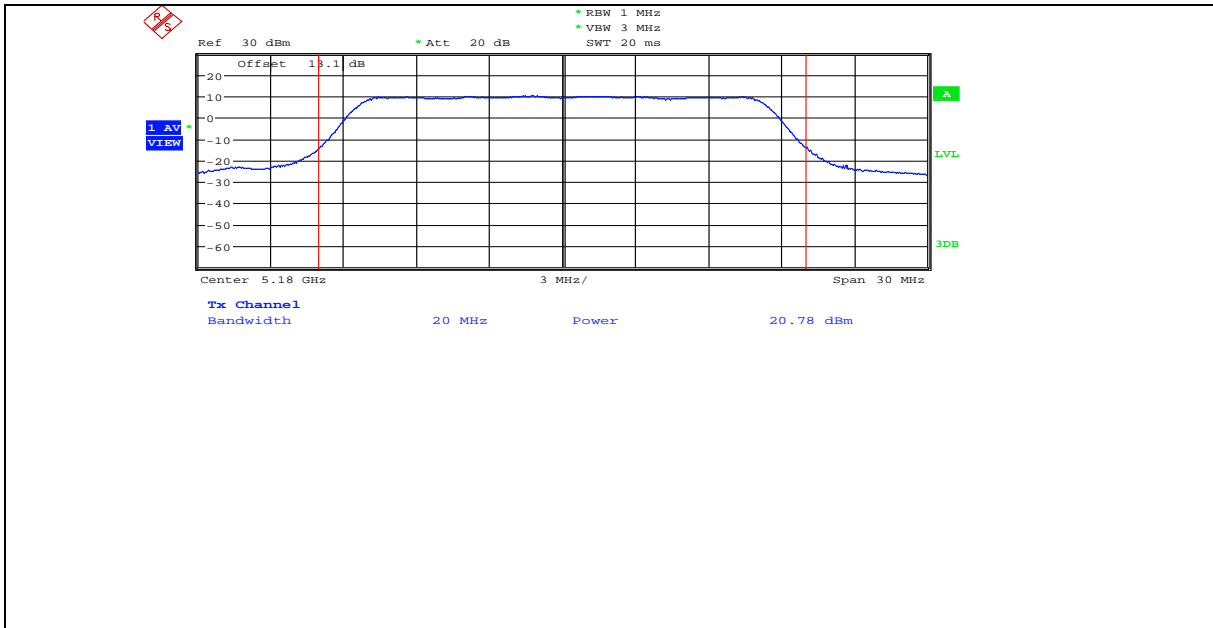

11ASISO ANT1\_5200

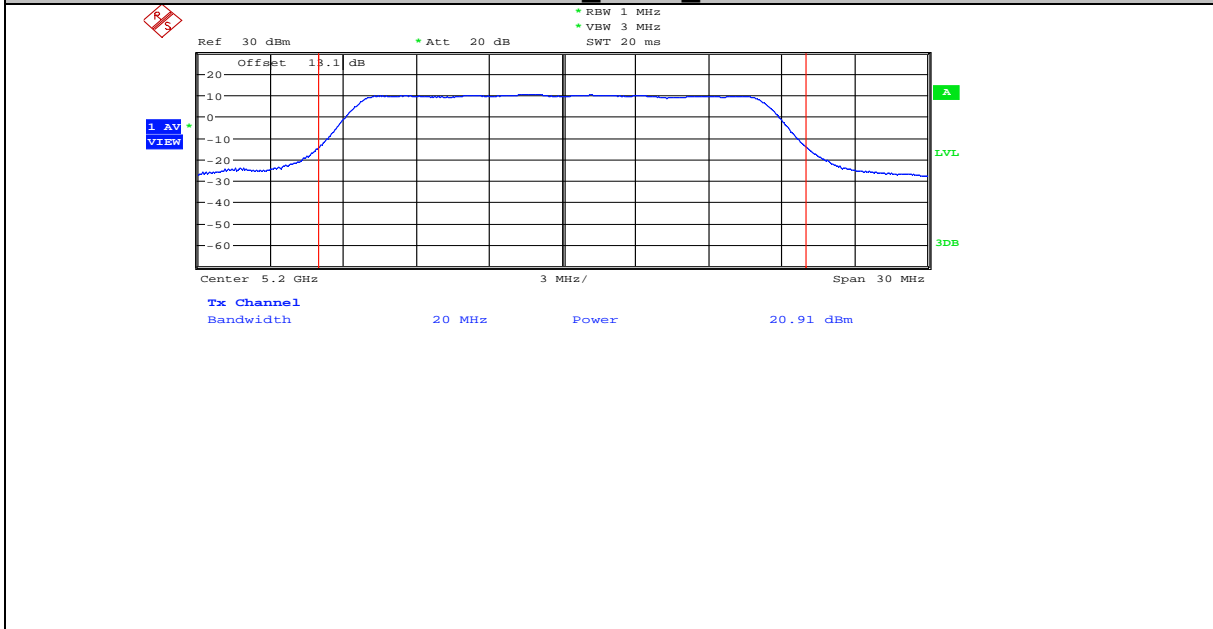

11ASISO ANT1\_5240

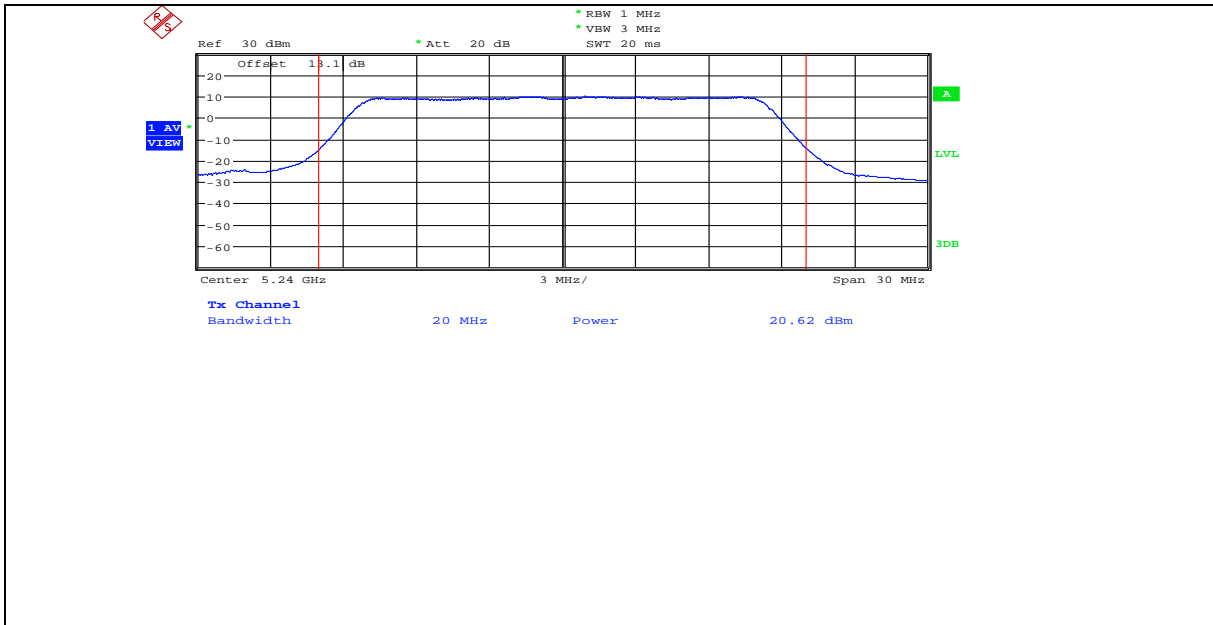

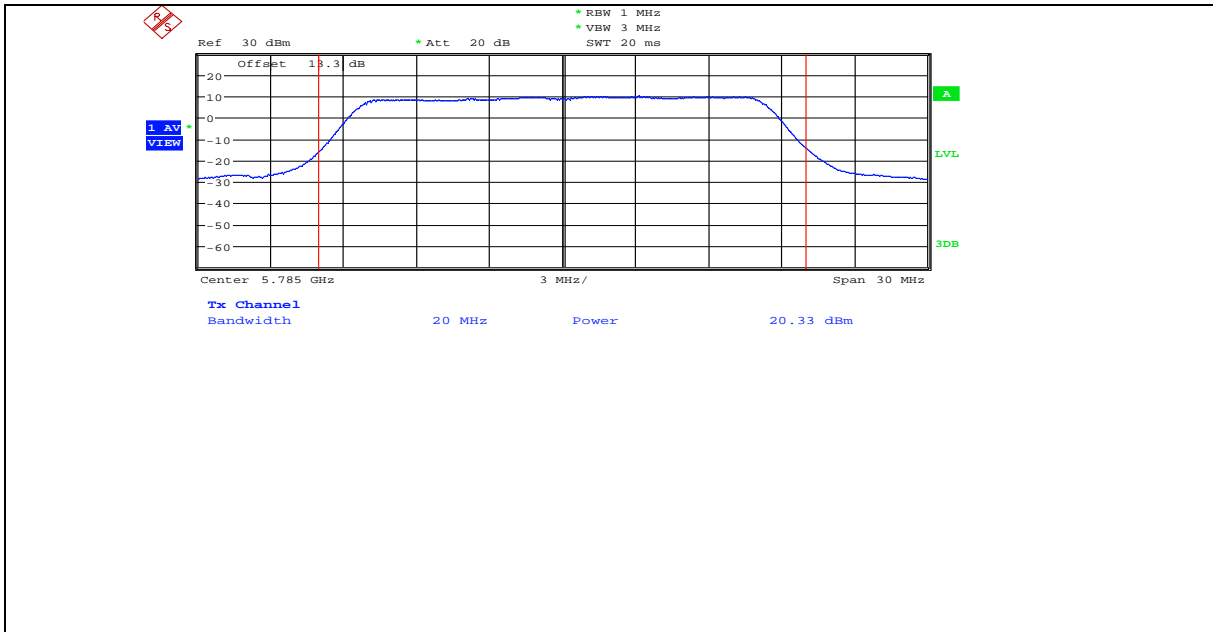

11ASISO\_ANT1\_5825

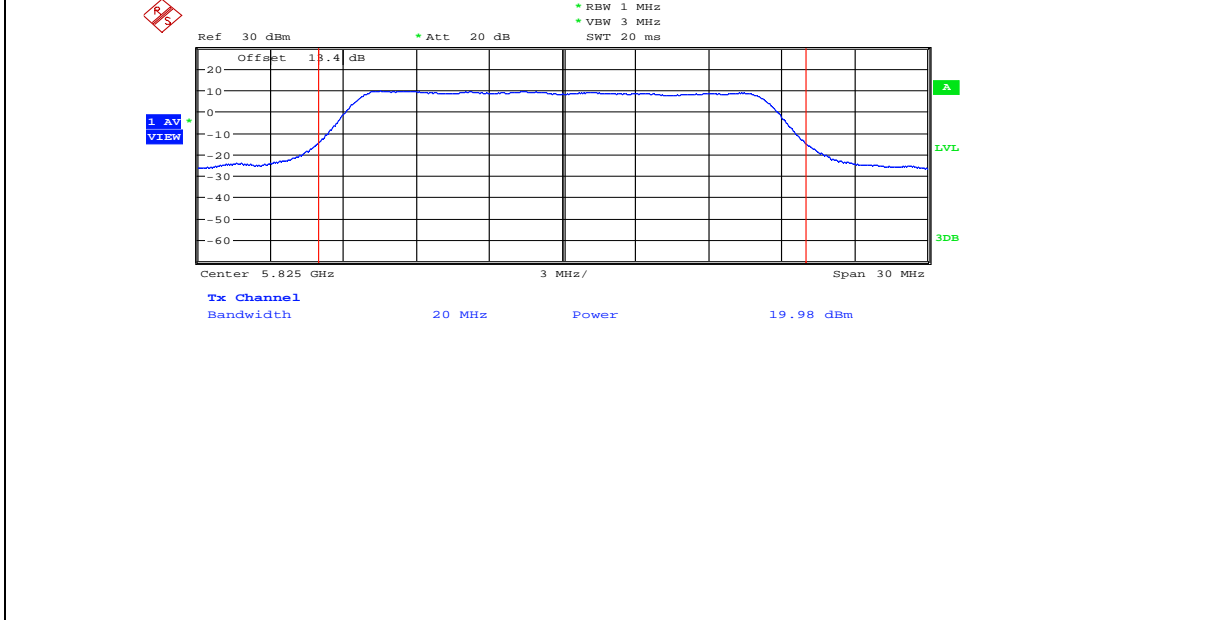



## 6. Power Spectral Density

### 6.1. Block diagram of test setup

Same with 4.1

### 6.2. Limits

FCC Part15, Subpart E		
Test Item	Limit	Frequency Range (MHz)
Power Spectral Density	For 802.11a: 17dBm/MHz For 802.11n and 802.11ac: 14.26dBm/MHz	5150-5250
	For 802.11a: 30dBm/500kHz For 802.11n and 802.11ac: 27.26dBm/500kHz	5725-5850
Note: For 802.11n and 802.11ac, the EUT incorporates a MIMO function. The Antenna directional gain is 8.74dBi. The UNII-1 Power Spectral Density limit is $17-(8.74-6)=14.26\text{dBm/MHz}$ The UNII-3 Power Spectral Density limit is $30-(8.74-6)=27.26\text{dBm/500kHz}$		

### 6.3. Test Procedure

The transmitter output was connected to a spectrum analyzer, use the following settings:  
5150MHz~5250MHz

Center Frequency	The centre frequency of the channel under test
Detector	RMS
RBW	1MHz
VBW	$\geq 3 \times \text{RBW}$
Span	Encompass the entire emissions bandwidth (EBW) of the signal
Trace	Max hold
Sweep time	Auto

5725MHz-5850MHz

Center Frequency	The centre frequency of the channel under test
Detector	RMS
RBW	500kHz
VBW	$\geq 3 \times \text{RBW}$
Span	Encompass the entire emissions bandwidth (EBW) of the signal
Trace	Max hold
Sweep time	Auto

Allow trace to fully stabilize and use the peak marker function to determine the maximum amplitude level within the RBW.

#### 6.4. Test Result

TestMode	Antenna	Channel	Result	Limit	Verdict
11N20MIMO	ANT1	5180	7.69	14.26	PASS
11N20MIMO	ANT2	5180	10.41	14.26	PASS
11N20MIMO	ANT3	5180	9.25	14.26	PASS
11N20MIMO	total	5180	14.03	14.26	PASS
11N20MIMO	ANT1	5200	7.14	14.26	PASS
11N20MIMO	ANT2	5200	7.51	14.26	PASS
11N20MIMO	ANT3	5200	6.42	14.26	PASS
11N20MIMO	total	5200	11.82	14.26	PASS
11N20MIMO	ANT1	5240	6.91	14.26	PASS
11N20MIMO	ANT2	5240	7.52	14.26	PASS
11N20MIMO	ANT3	5240	6.48	14.26	PASS
11N20MIMO	total	5240	11.76	14.26	PASS
11N20MIMO	ANT1	5745	7.86	27.26	PASS
11N20MIMO	ANT2	5745	7.88	27.26	PASS
11N20MIMO	ANT3	5745	8.64	27.26	PASS
11N20MIMO	total	5745	12.91	27.26	PASS
11N20MIMO	ANT1	5785	8.04	27.26	PASS
11N20MIMO	ANT2	5785	8.94	27.26	PASS
11N20MIMO	ANT3	5785	7.69	27.26	PASS
11N20MIMO	total	5785	13.03	27.26	PASS
11N20MIMO	ANT1	5825	5.98	27.26	PASS
11N20MIMO	ANT2	5825	8.67	27.26	PASS
11N20MIMO	ANT3	5825	7.34	27.26	PASS
11N20MIMO	total	5825	12.24	27.26	PASS
11N40MIMO	ANT1	5190	5.94	14.26	PASS
11N40MIMO	ANT2	5190	8.71	14.26	PASS
11N40MIMO	ANT3	5190	7.79	14.26	PASS
11N40MIMO	total	5190	12.40	14.26	PASS
11N40MIMO	ANT1	5230	7.18	14.26	PASS
11N40MIMO	ANT2	5230	6.50	14.26	PASS
11N40MIMO	ANT3	5230	8.13	14.26	PASS
11N40MIMO	total	5230	12.09	14.26	PASS
11N40MIMO	ANT1	5755	6.6	27.26	PASS
11N40MIMO	ANT2	5755	3.95	27.26	PASS
11N40MIMO	ANT3	5755	6.57	27.26	PASS
11N40MIMO	total	5755	10.64	27.26	PASS
11N40MIMO	ANT1	5795	6.93	27.26	PASS

11N40MIMO	ANT2	5795	5.72	27.26	PASS
11N40MIMO	ANT3	5795	6.47	27.26	PASS
11N40MIMO	total	5795	11.17	27.26	PASS
11AC20MIMO	ANT1	5180	9.56	14.26	PASS
11AC20MIMO	ANT2	5180	9.11	14.26	PASS
11AC20MIMO	ANT3	5180	8.33	14.26	PASS
11AC20MIMO	total	5180	13.80	14.26	PASS
11AC20MIMO	ANT1	5200	7.61	14.26	PASS
11AC20MIMO	ANT2	5200	8.24	14.26	PASS
11AC20MIMO	ANT3	5200	8.46	14.26	PASS
11AC20MIMO	total	5200	12.89	14.26	PASS
11AC20MIMO	ANT1	5240	9.07	14.26	PASS
11AC20MIMO	ANT2	5240	8.34	14.26	PASS
11AC20MIMO	ANT3	5240	5.69	14.26	PASS
11AC20MIMO	total	5240	12.70	14.26	PASS
11AC20MIMO	ANT1	5745	6.79	27.26	PASS
11AC20MIMO	ANT2	5745	5.30	27.26	PASS
11AC20MIMO	ANT3	5745	6.87	27.26	PASS
11AC20MIMO	total	5745	11.15	27.26	PASS
11AC20MIMO	ANT1	5785	5.04	27.26	PASS
11AC20MIMO	ANT2	5785	2.75	27.26	PASS
11AC20MIMO	ANT3	5785	4.95	27.26	PASS
11AC20MIMO	total	5785	9.14	27.26	PASS
11AC20MIMO	ANT1	5825	3.67	27.26	PASS
11AC20MIMO	ANT2	5825	4.65	27.26	PASS
11AC20MIMO	ANT3	5825	4.51	27.26	PASS
11AC20MIMO	total	5825	9.07	27.26	PASS
11AC40MIMO	ANT1	5190	5.03	14.26	PASS
11AC40MIMO	ANT2	5190	6.65	14.26	PASS
11AC40MIMO	ANT3	5190	5.45	14.26	PASS
11AC40MIMO	total	5190	10.54	14.26	PASS
11AC40MIMO	ANT1	5230	6.23	14.26	PASS
11AC40MIMO	ANT2	5230	5.74	14.26	PASS
11AC40MIMO	ANT3	5230	3.32	14.26	PASS
11AC40MIMO	total	5230	10.04	14.26	PASS
11AC40MIMO	ANT1	5755	4.79	27.26	PASS
11AC40MIMO	ANT2	5755	4.26	27.26	PASS
11AC40MIMO	ANT3	5755	4.13	27.26	PASS
11AC40MIMO	total	5755	9.17	27.26	PASS

11AC40MIMO	ANT1	5795	4.04	27.26	PASS
11AC40MIMO	ANT2	5795	1.26	27.26	PASS
11AC40MIMO	ANT3	5795	3.84	27.26	PASS
11AC40MIMO	total	5795	7.99	27.26	PASS
11AC80MIMO	ANT1	5210	3.86	14.26	PASS
11AC80MIMO	ANT2	5210	3.11	14.26	PASS
11AC80MIMO	ANT3	5210	1.23	14.26	PASS
11AC80MIMO	total	5210	7.64	14.26	PASS
11AC80MIMO	ANT1	5775	1.55	27.26	PASS
11AC80MIMO	ANT2	5775	-0.51	27.26	PASS
11AC80MIMO	ANT3	5775	1.24	27.26	PASS
11AC80MIMO	total	5775	5.62	27.26	PASS
11ASISO	ANT1	5180	9.90	17	PASS
11ASISO	ANT1	5200	10.07	17	PASS
11ASISO	ANT1	5240	9.81	17	PASS
11ASISO	ANT1	5745	8.5	30	PASS
11ASISO	ANT1	5785	7.26	30	PASS
11ASISO	ANT1	5825	7.43	30	PASS

### 6.5. Original test data

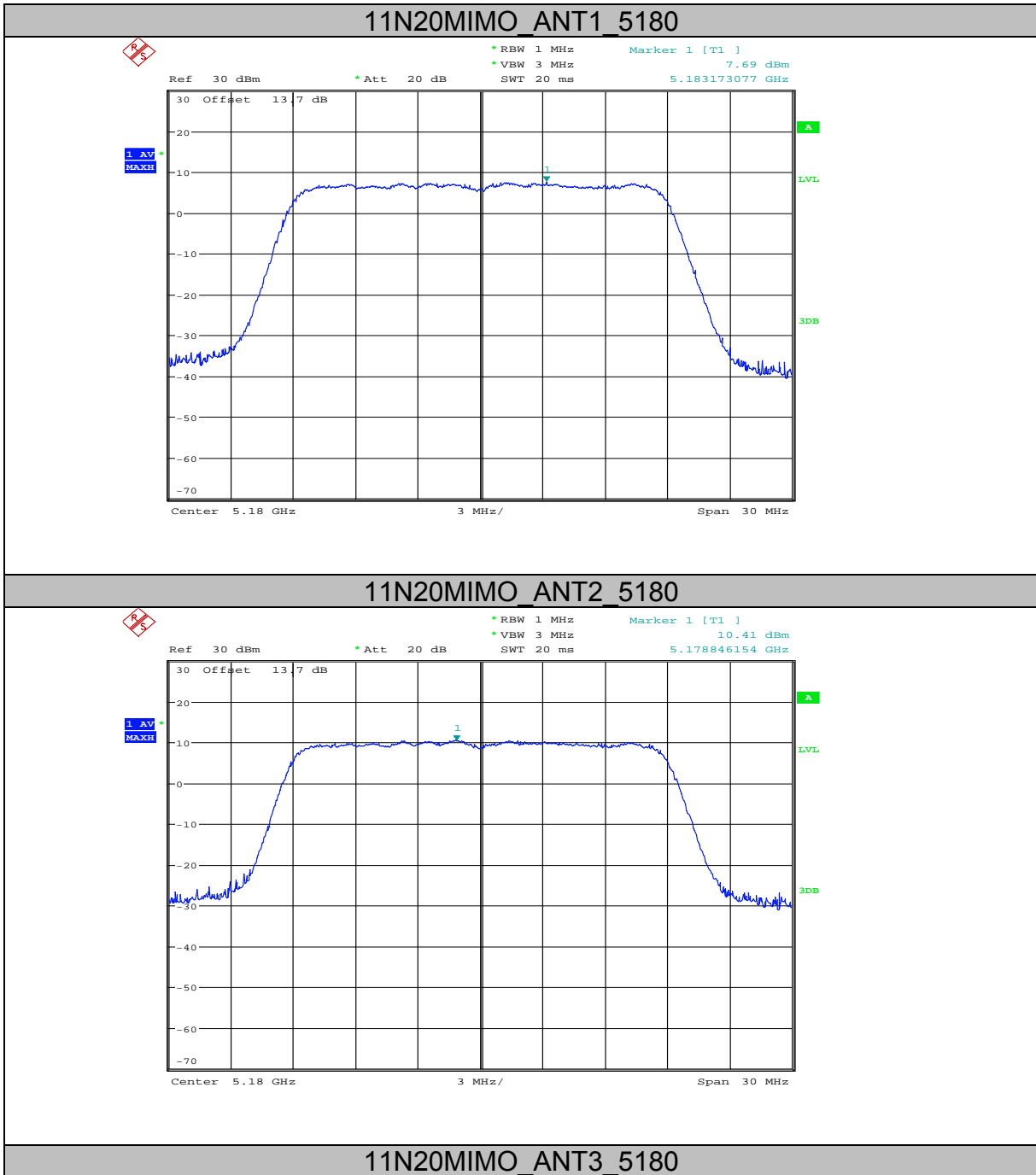

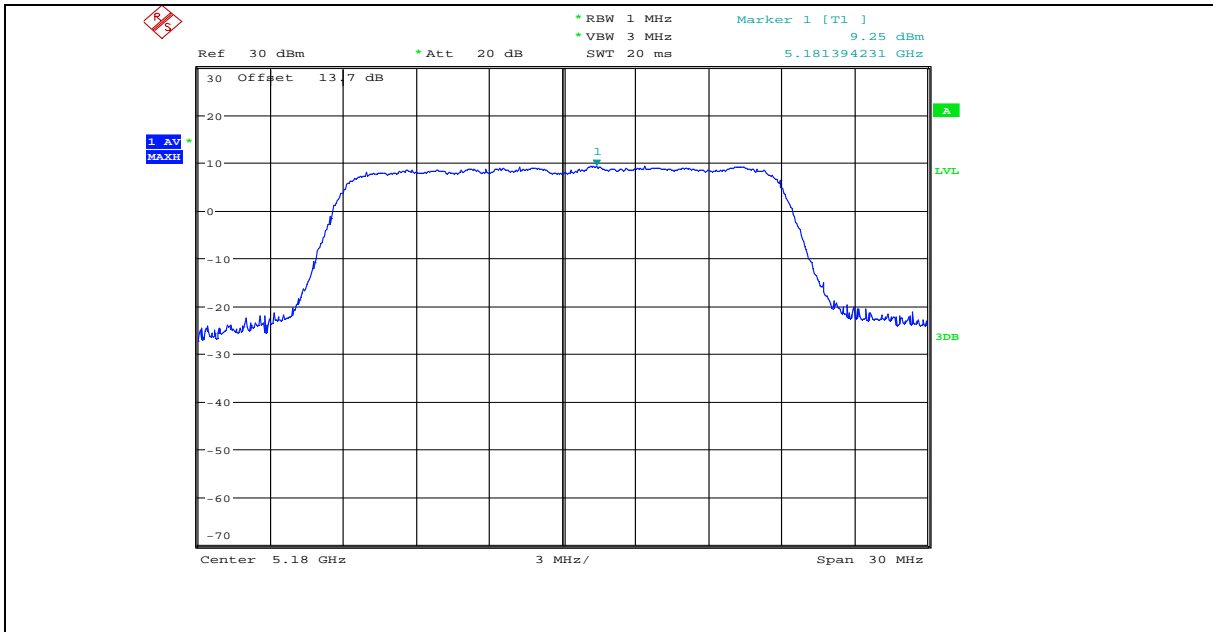

11N20MIMO\_ANT1\_5200

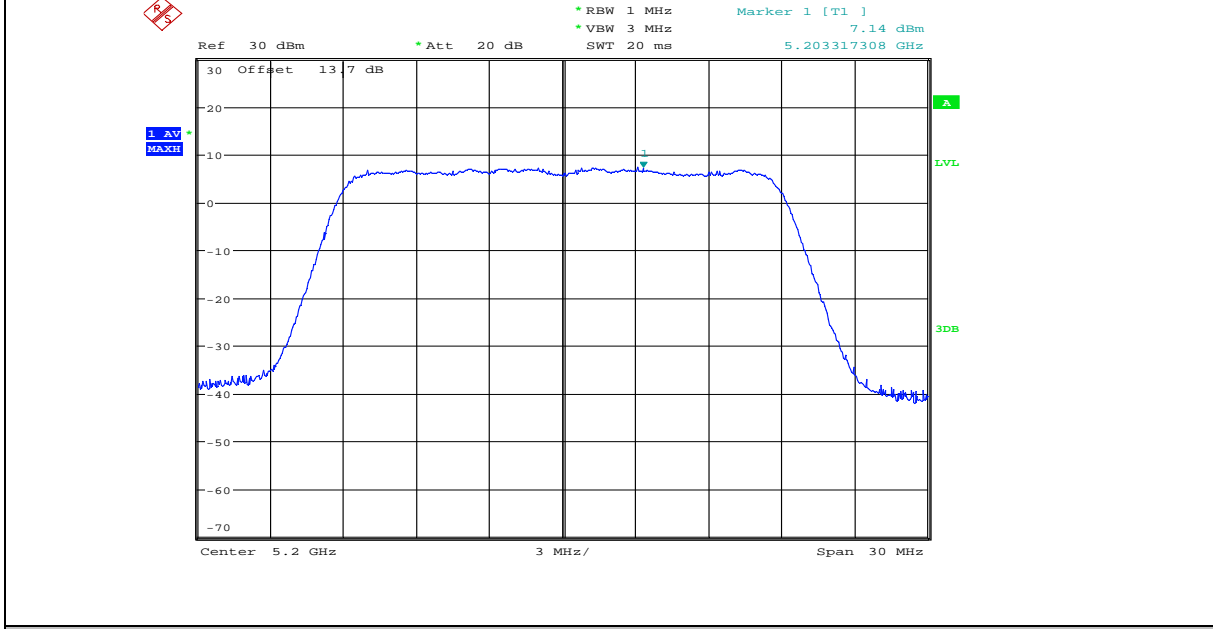

11N20MIMO\_ANT2\_5200

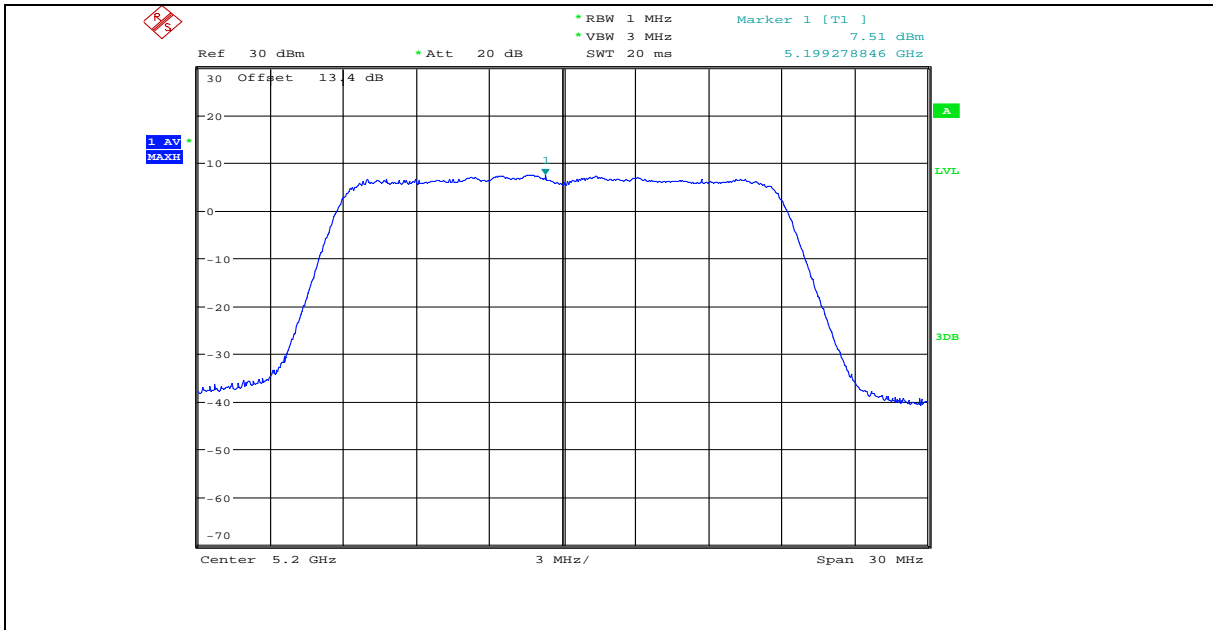

11N20MIMO\_ANT3\_5200

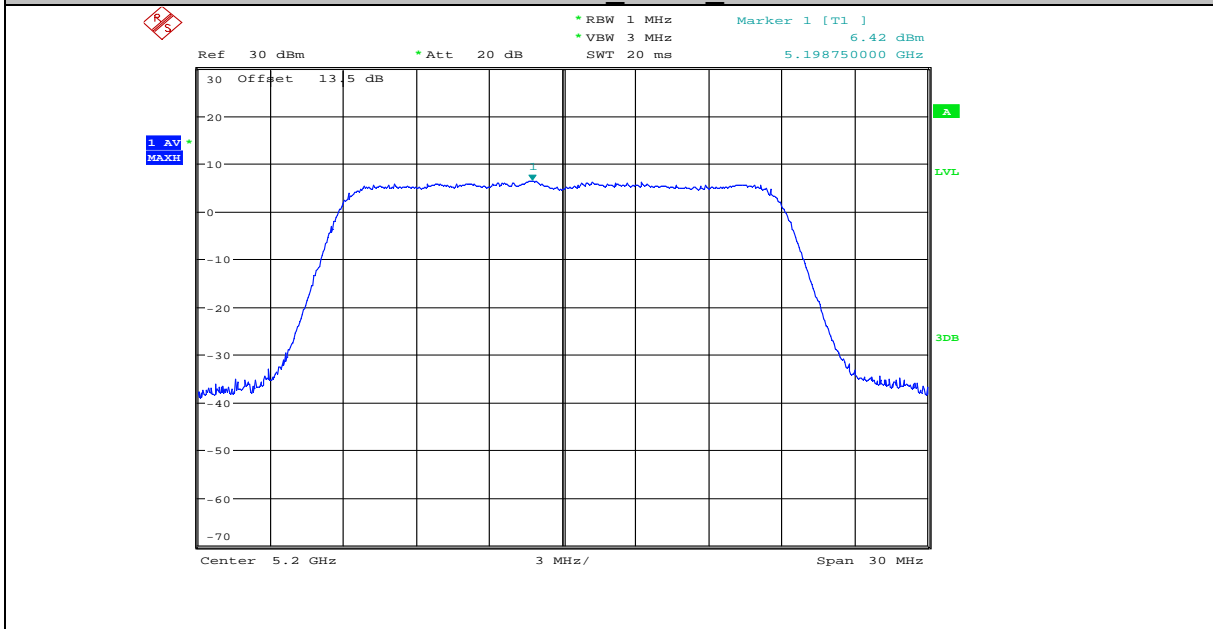

11N20MIMO\_ANT1\_5240

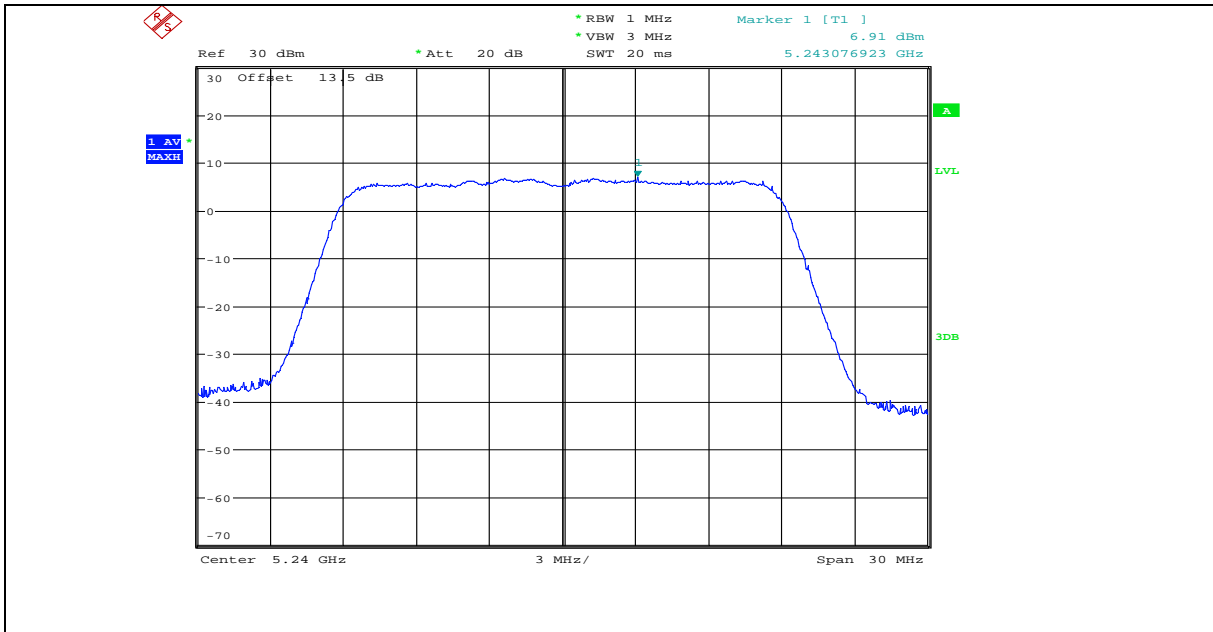

11N20MIMO\_ANT2\_5240

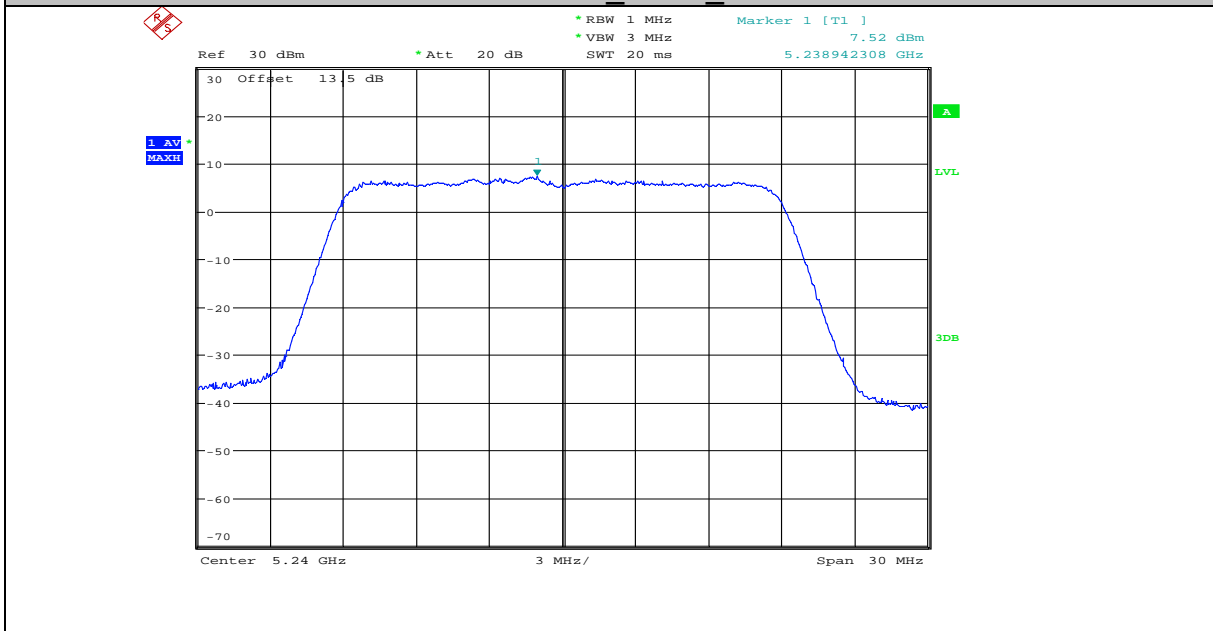

11N20MIMO\_ANT3\_5240



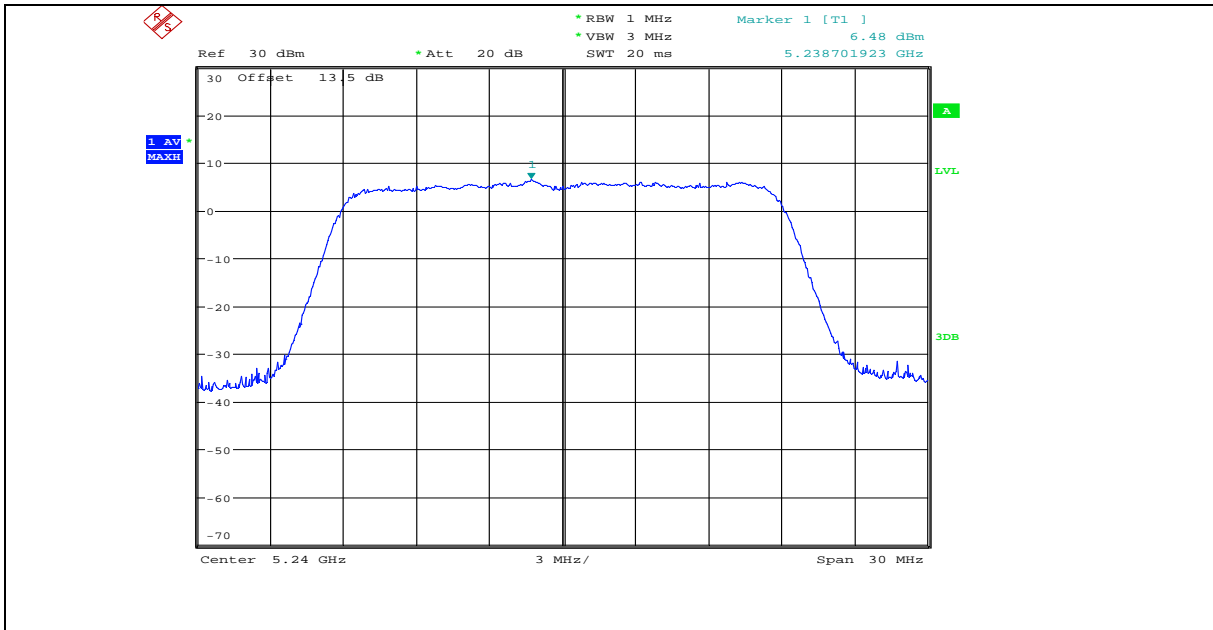

11N20MIMO\_ANT1\_5745

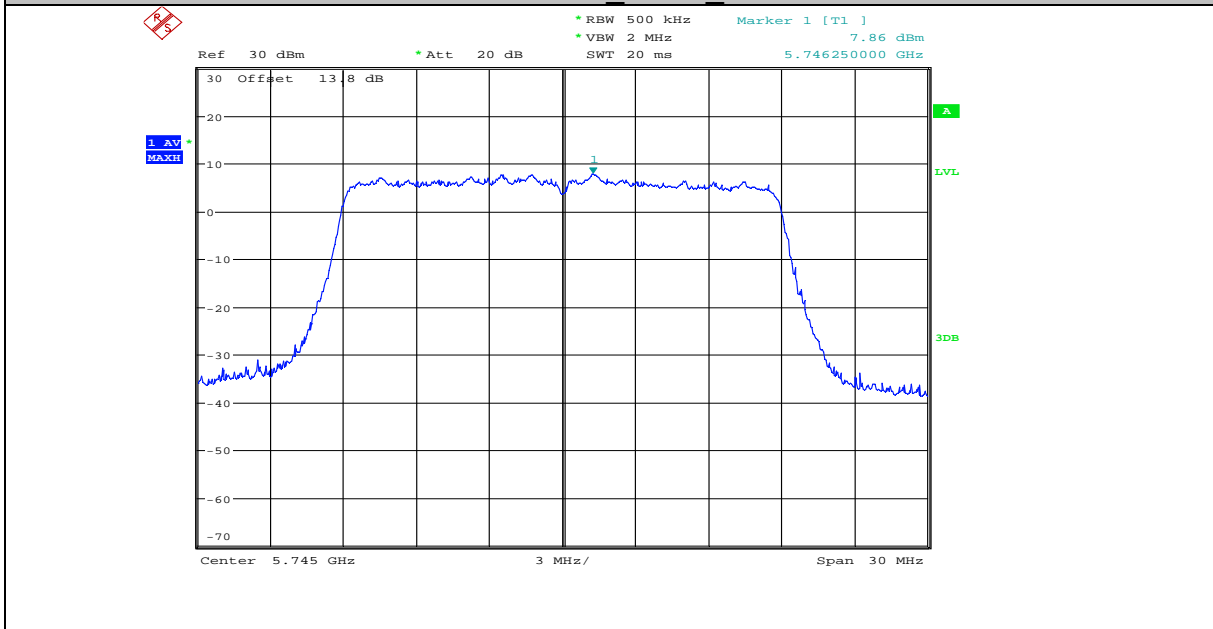

11N20MIMO\_ANT2\_5745

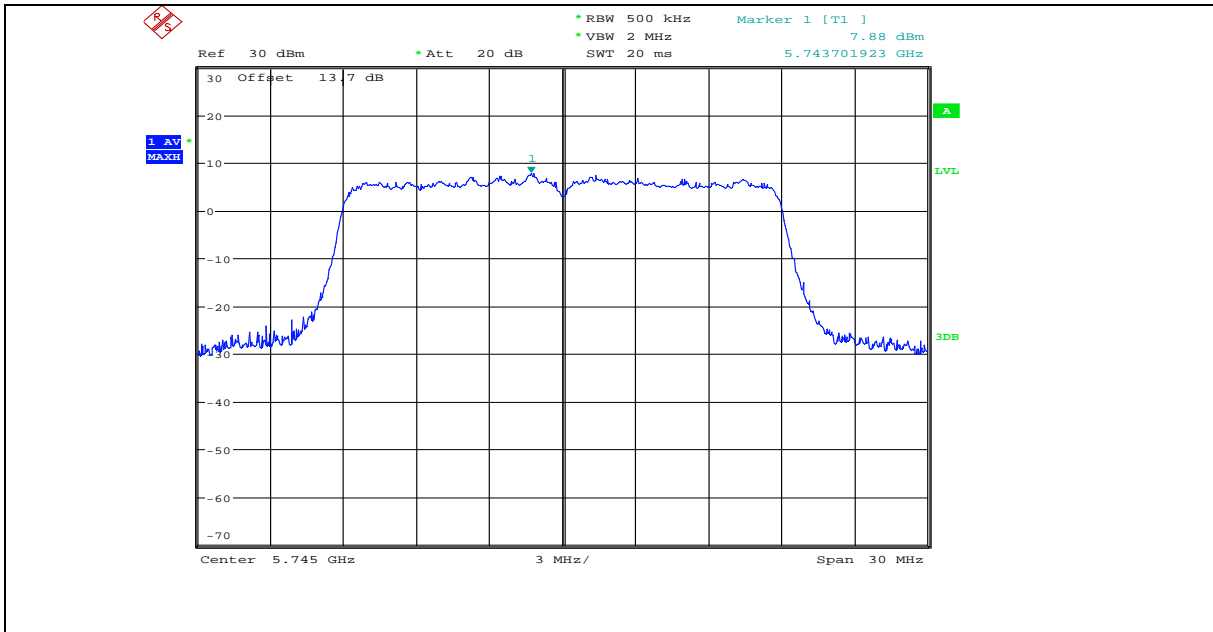

11N20MIMO ANT3 5745

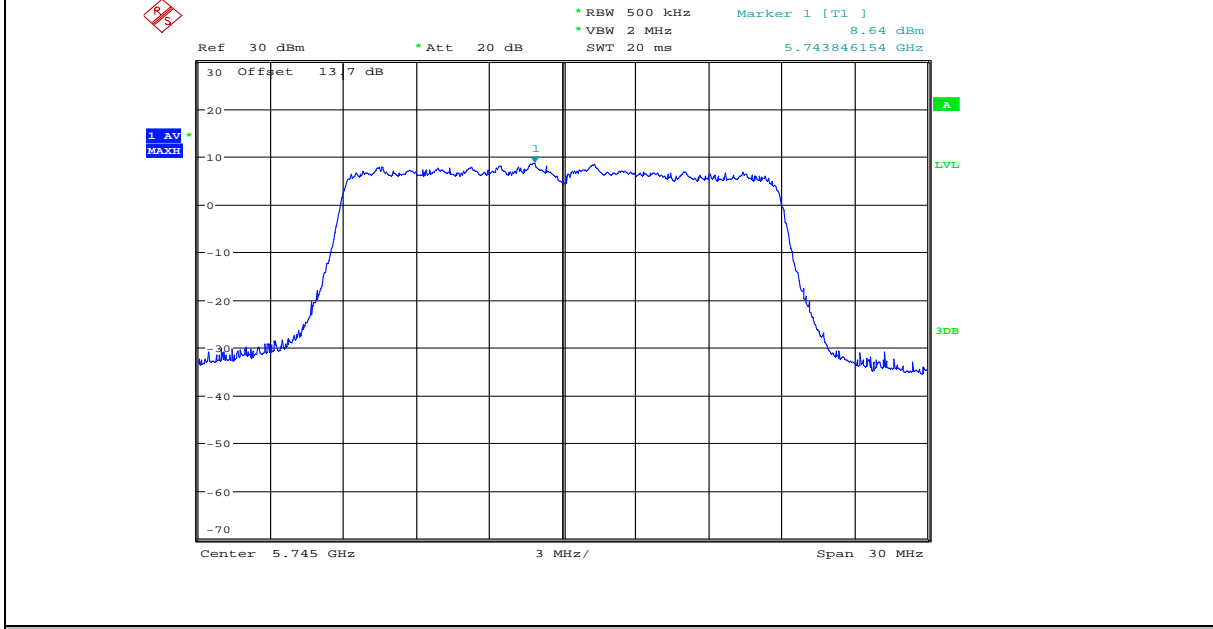

11N20MIMO ANT1 5785

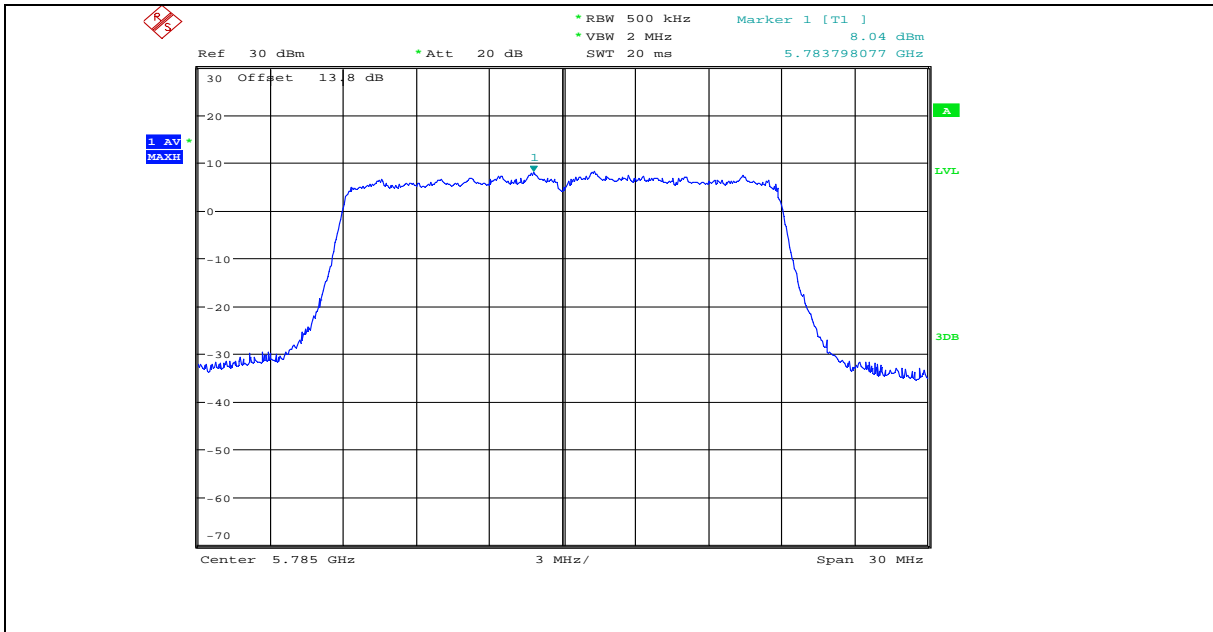

11N20MIMO\_ANT2\_5785

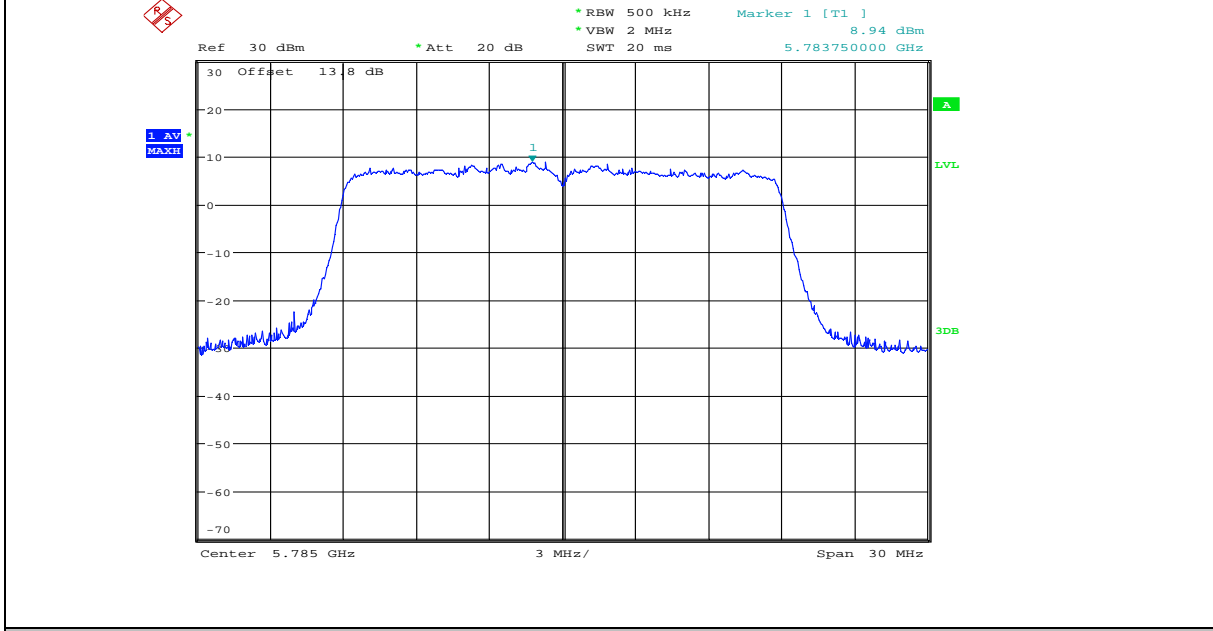

11N20MIMO\_ANT3\_5785

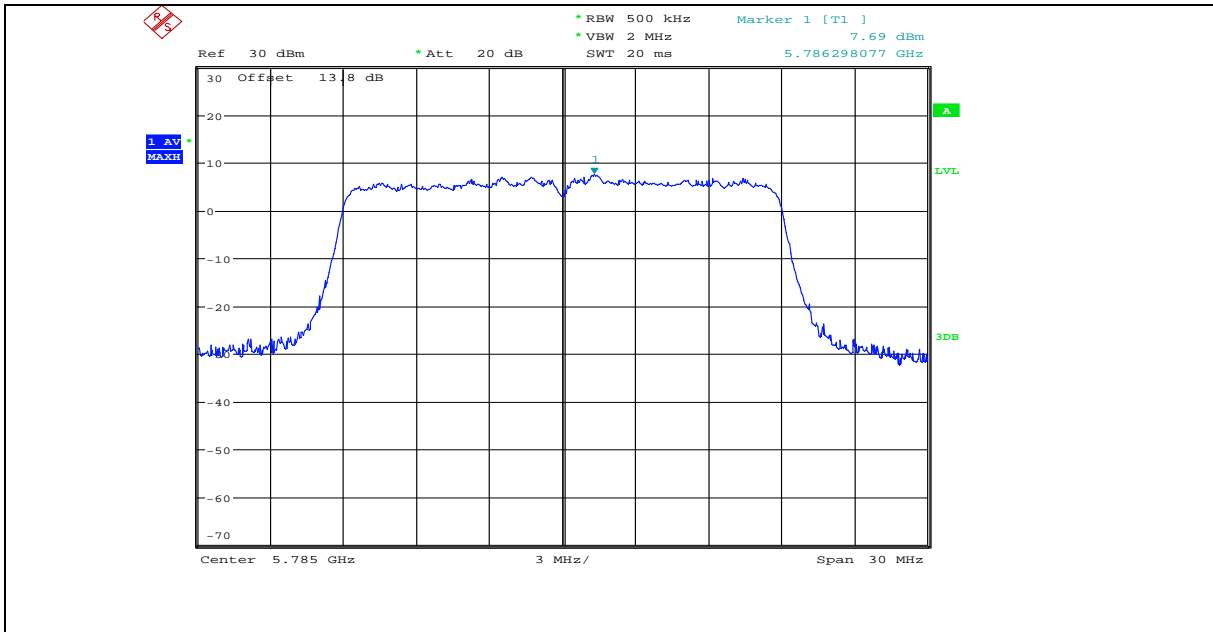

11N20MIMO\_ANT1\_5825

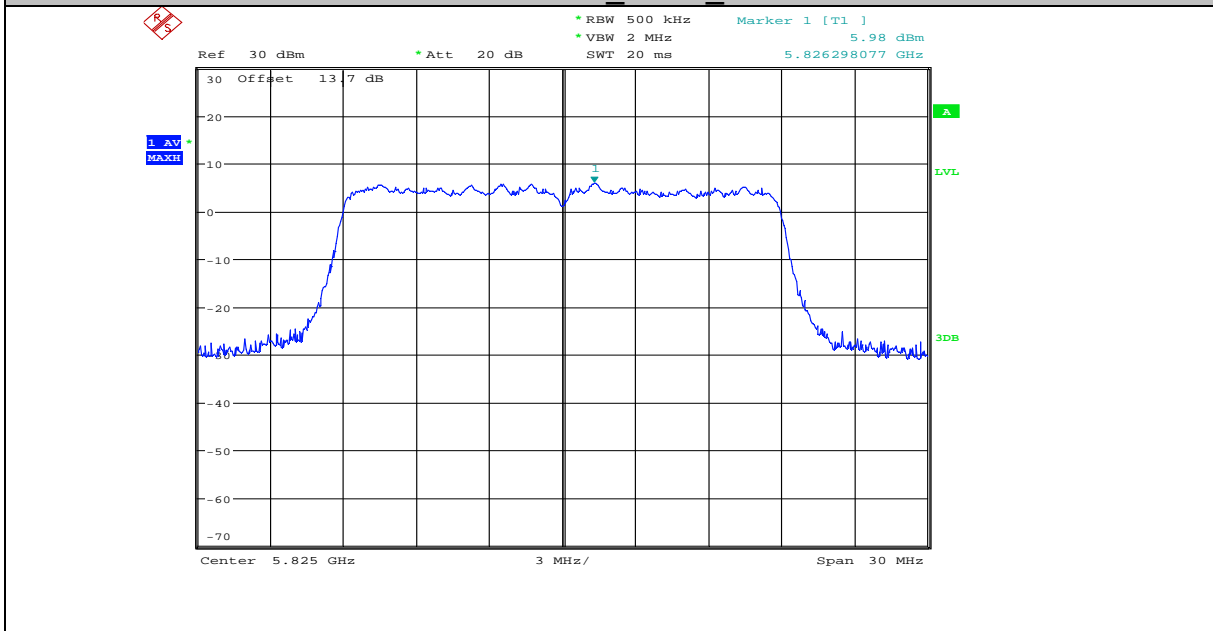

11N20MIMO\_ANT2\_5825

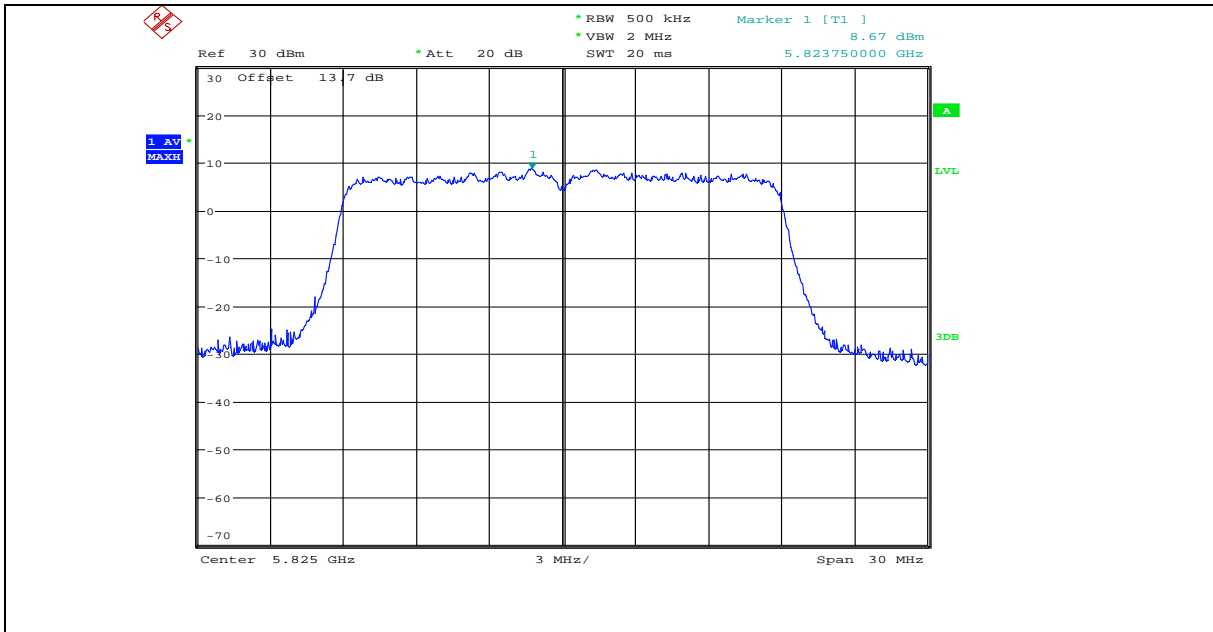

11N20MIMO\_ANT3\_5825

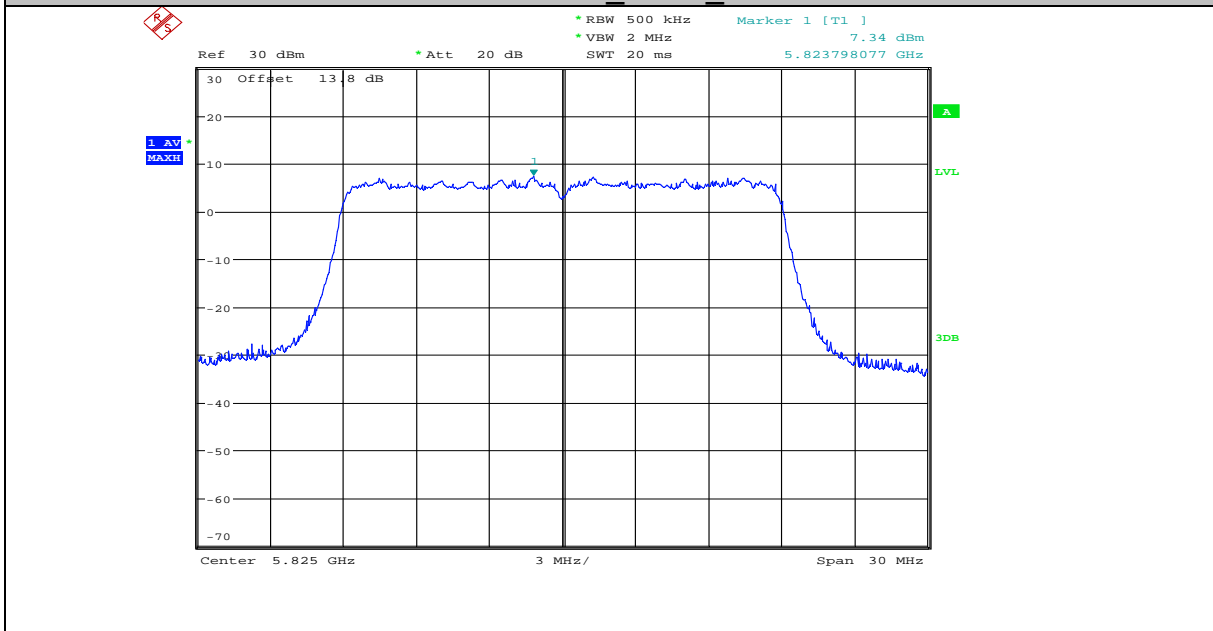

11N40MIMO\_ANT1\_5190

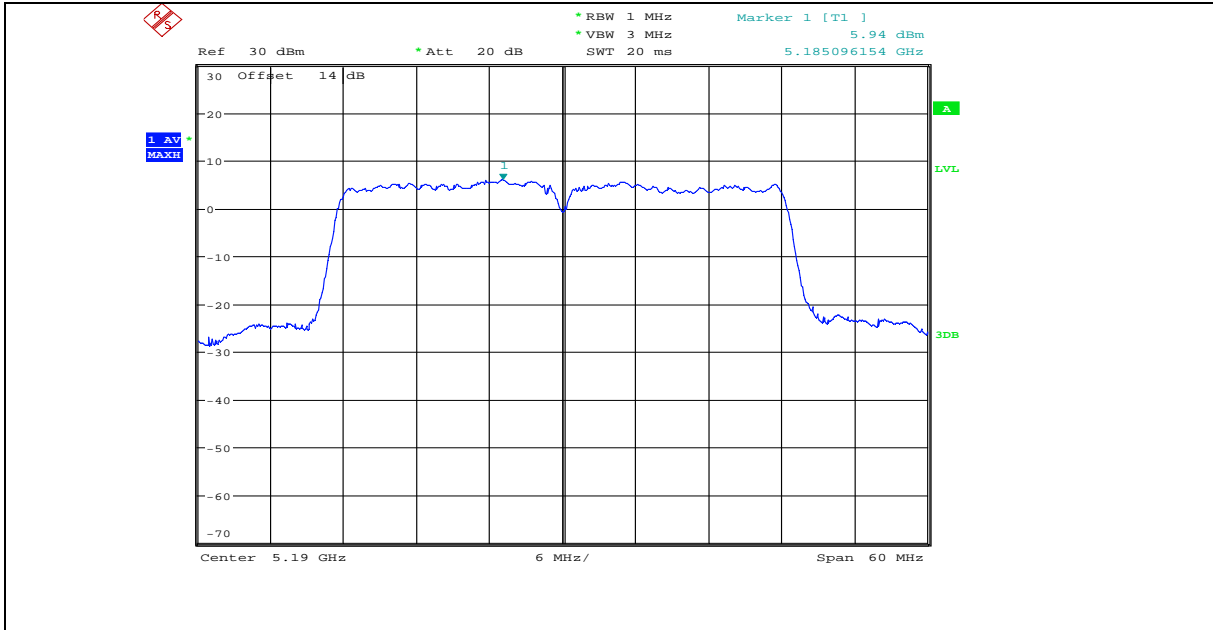

11N40MIMO\_ANT2\_5190

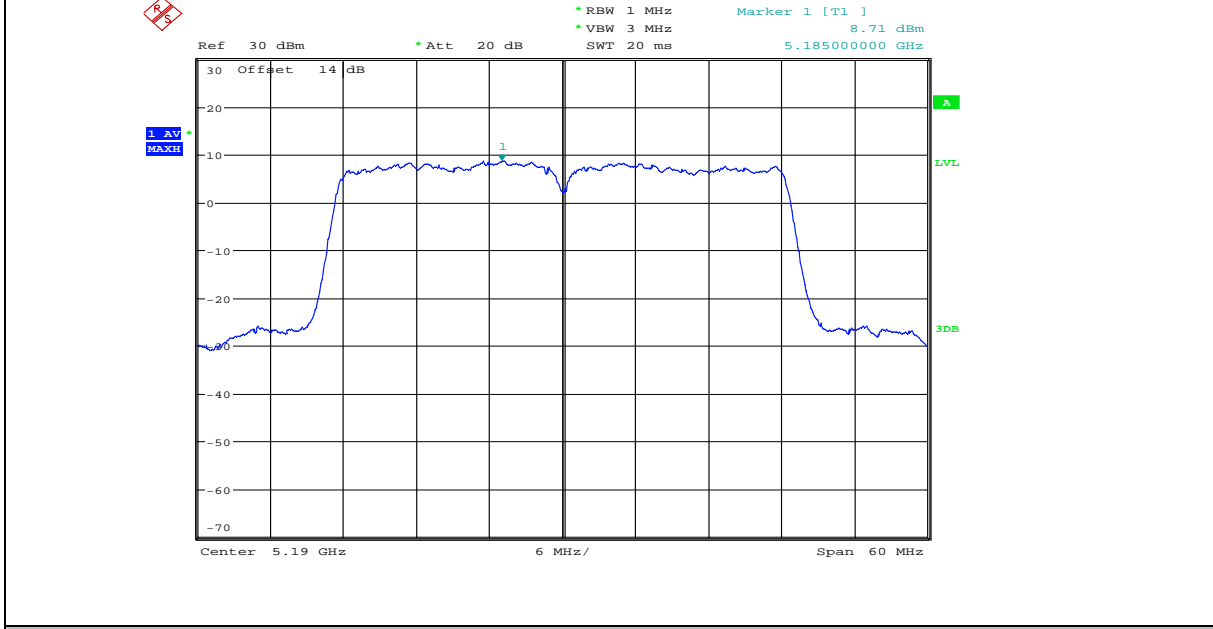

11N40MIMO\_ANT3\_5190

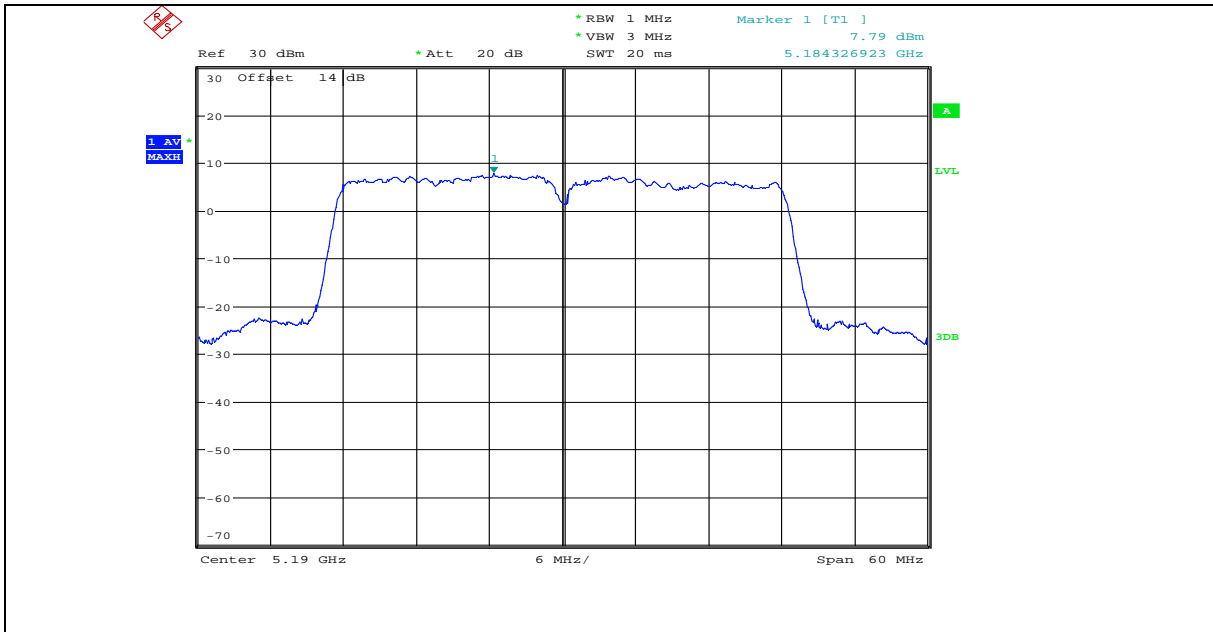

11N40MIMO ANT1 5230

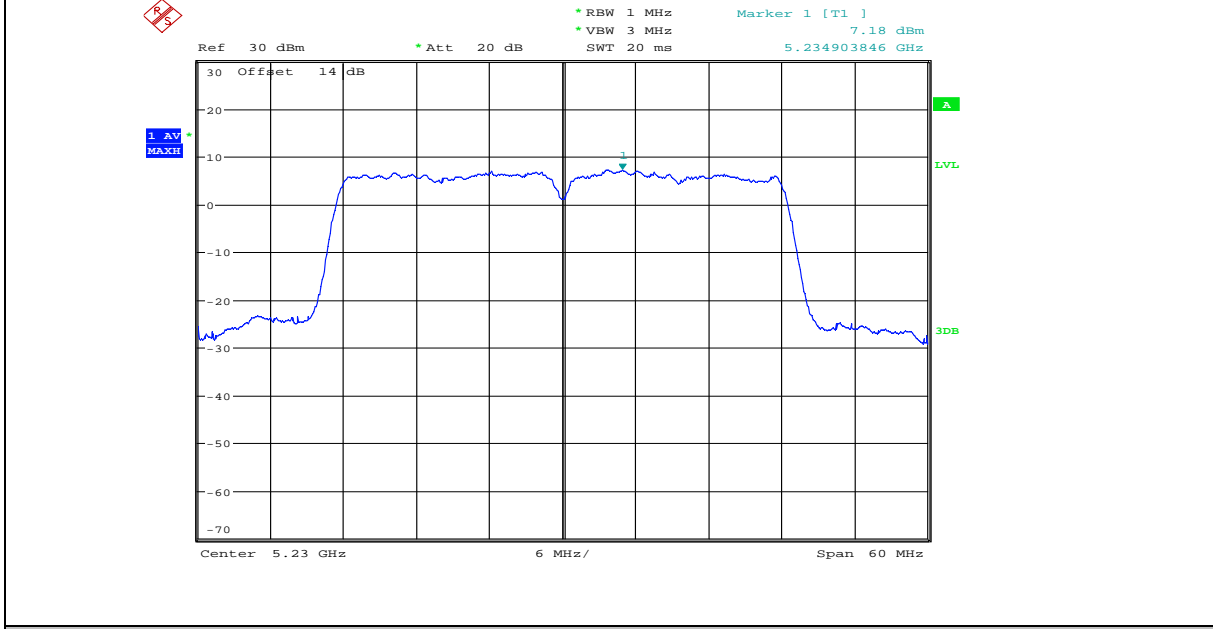

11N40MIMO ANT2 5230

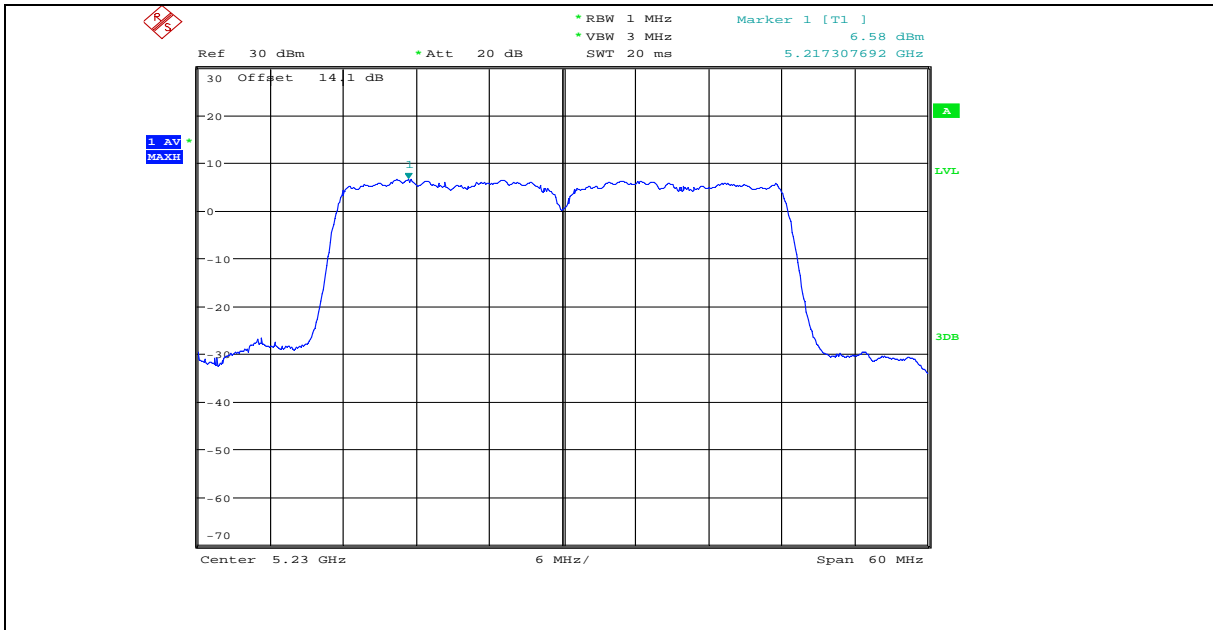

11N40MIMO ANT3 5230

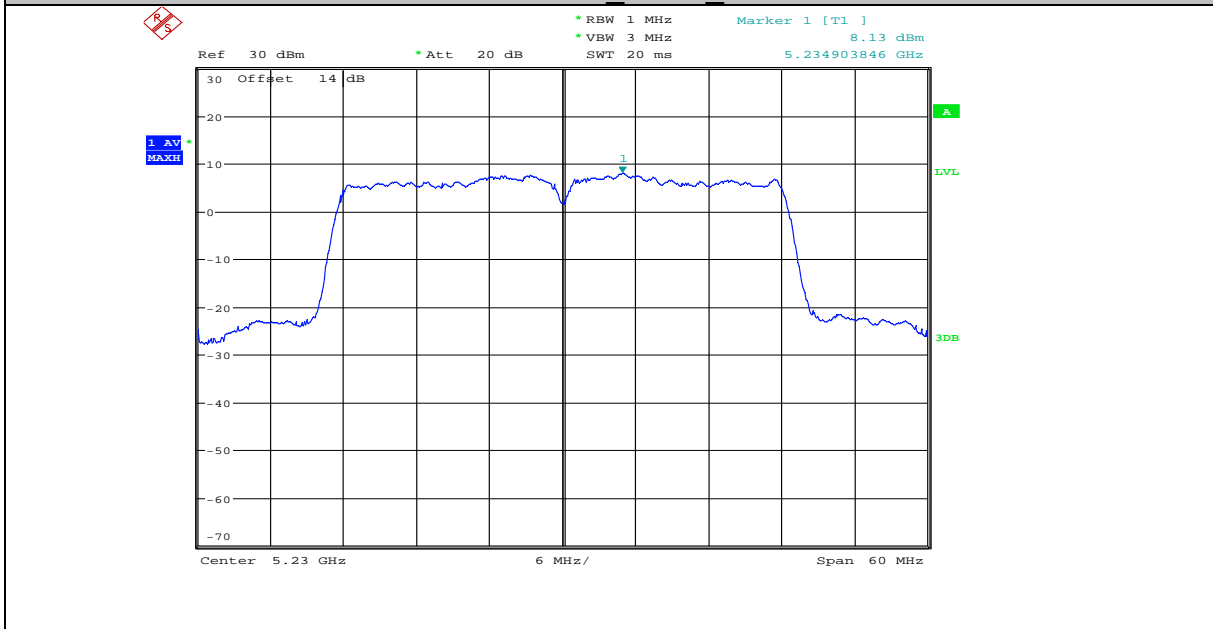

11N40MIMO ANT1 5755



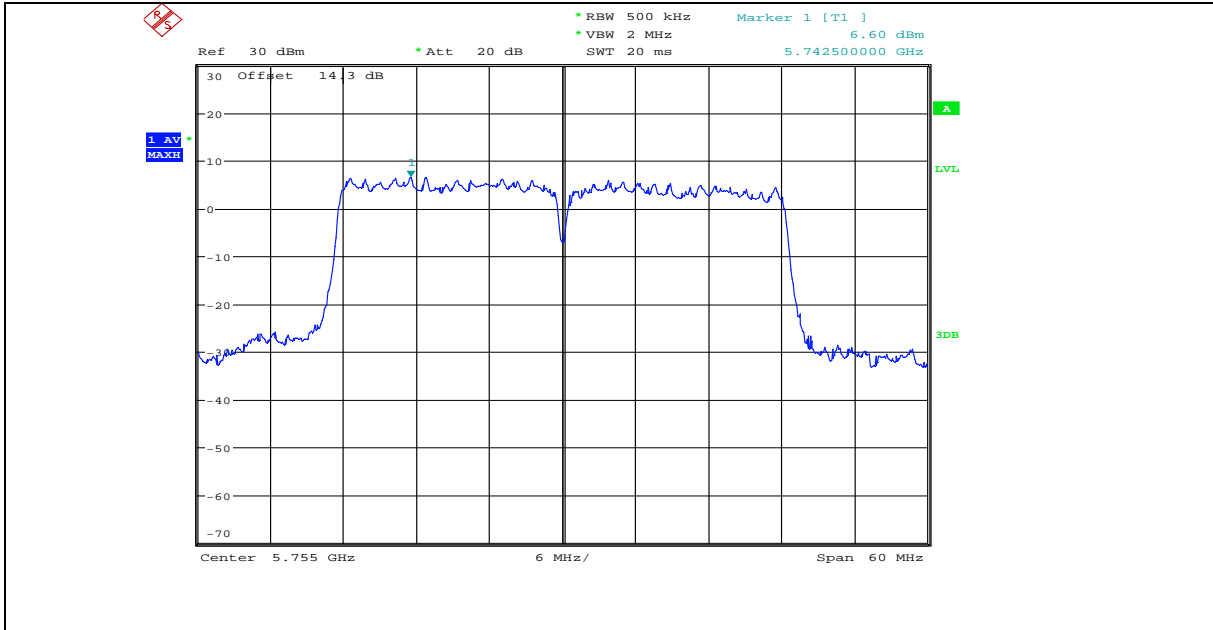

11N40MIMO\_ANT2\_5755

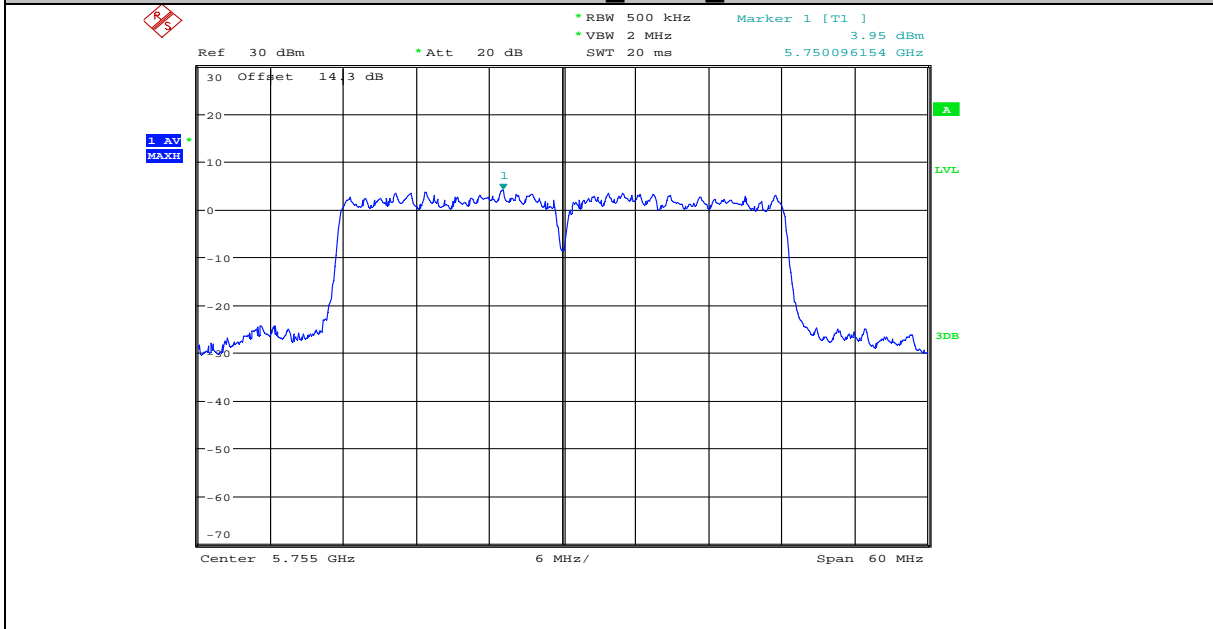

11N40MIMO\_ANT3\_5755

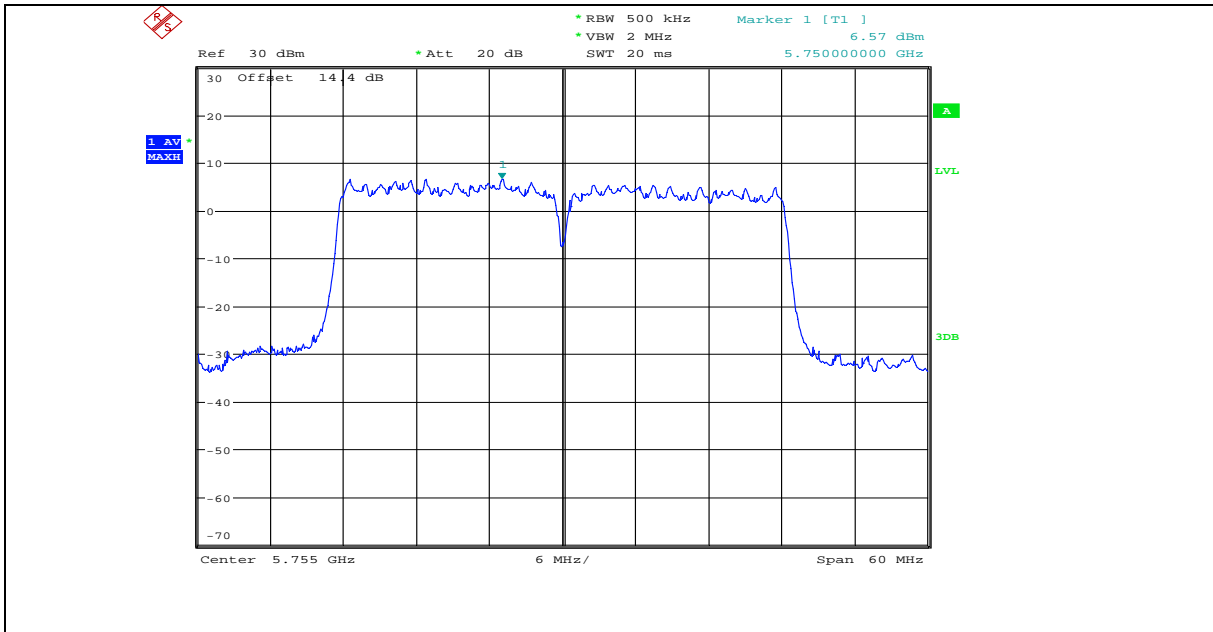

11N40MIMO ANT1 5795

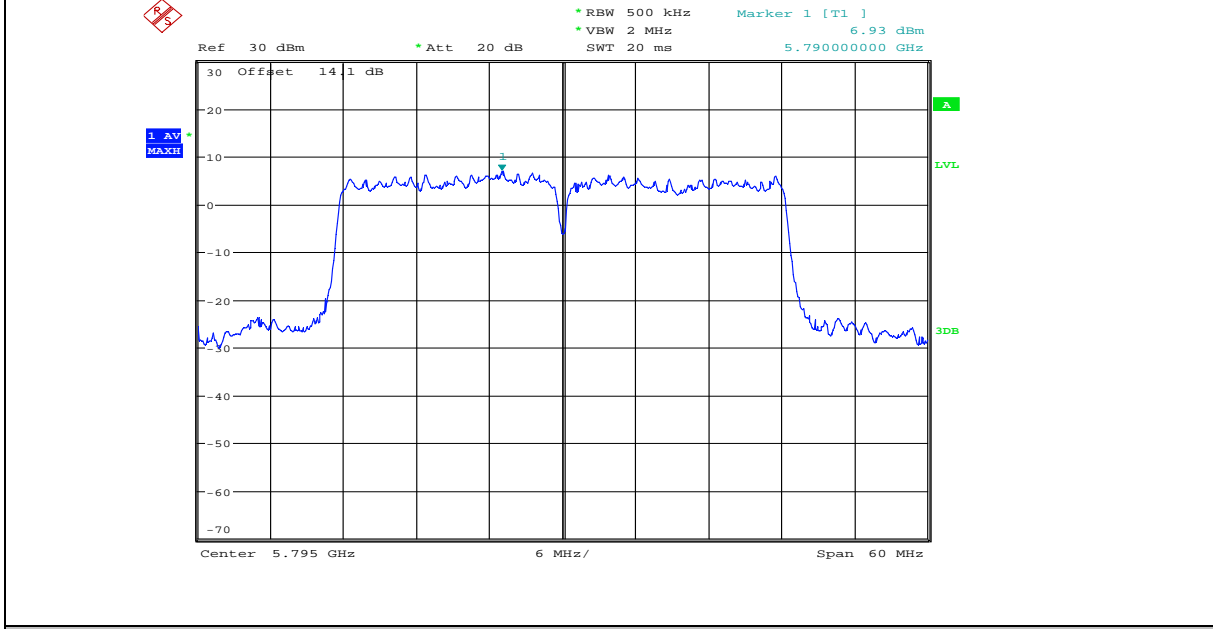

11N40MIMO ANT2 5795

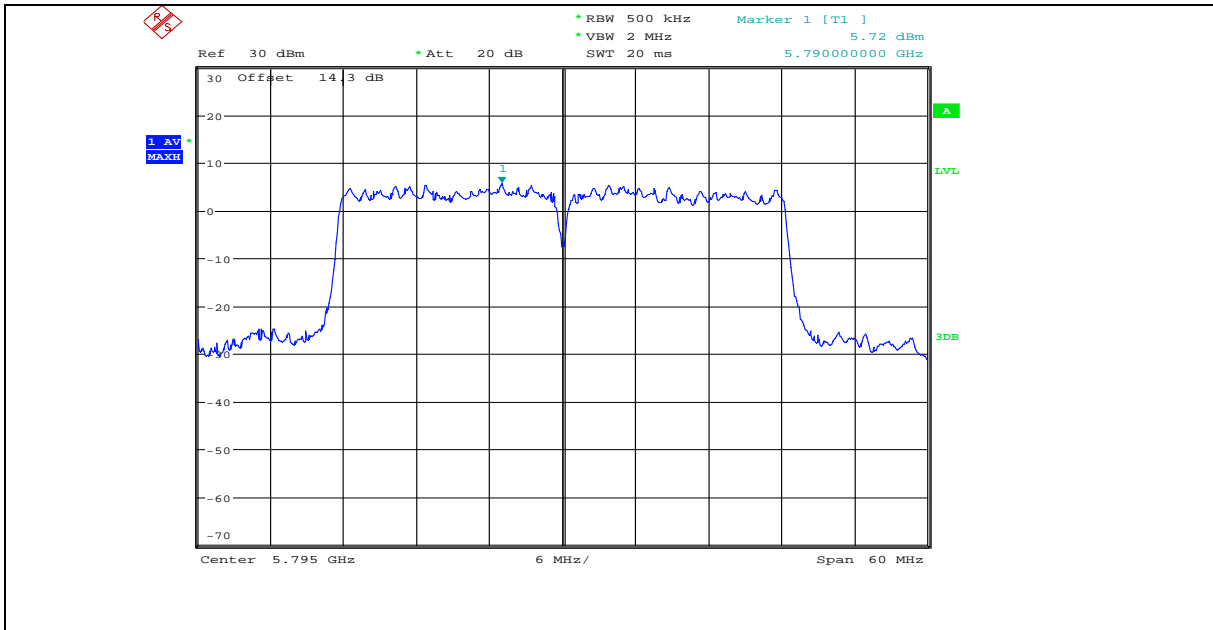

11N40MIMO\_ANT3\_5795

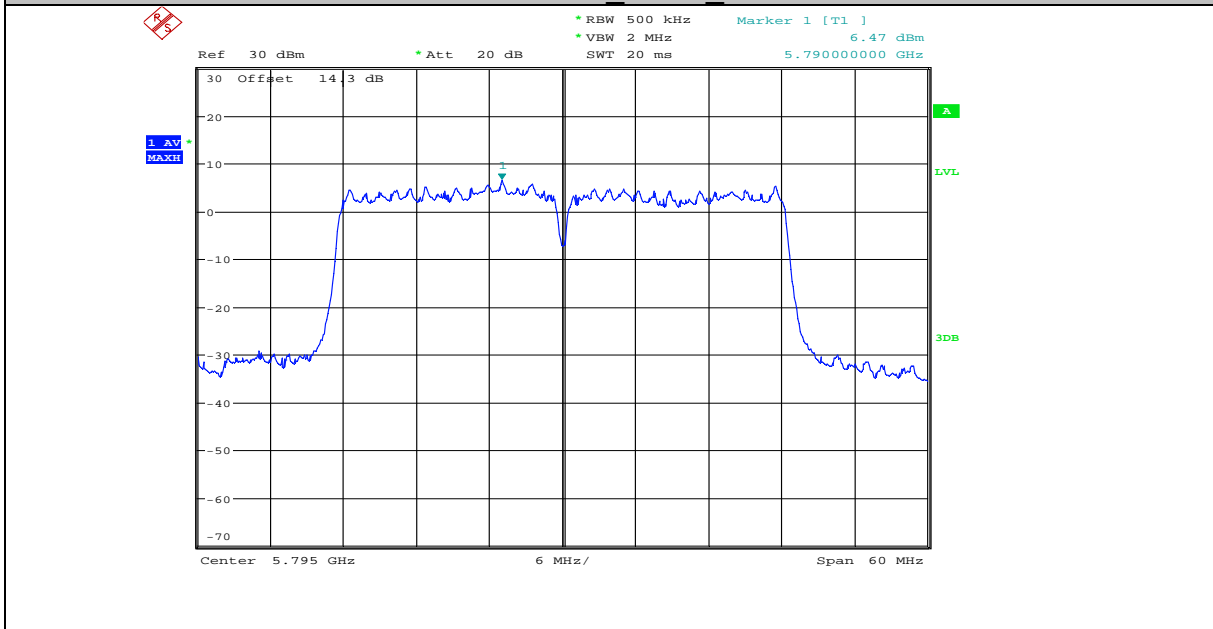

11AC20MIMO\_ANT1\_5180

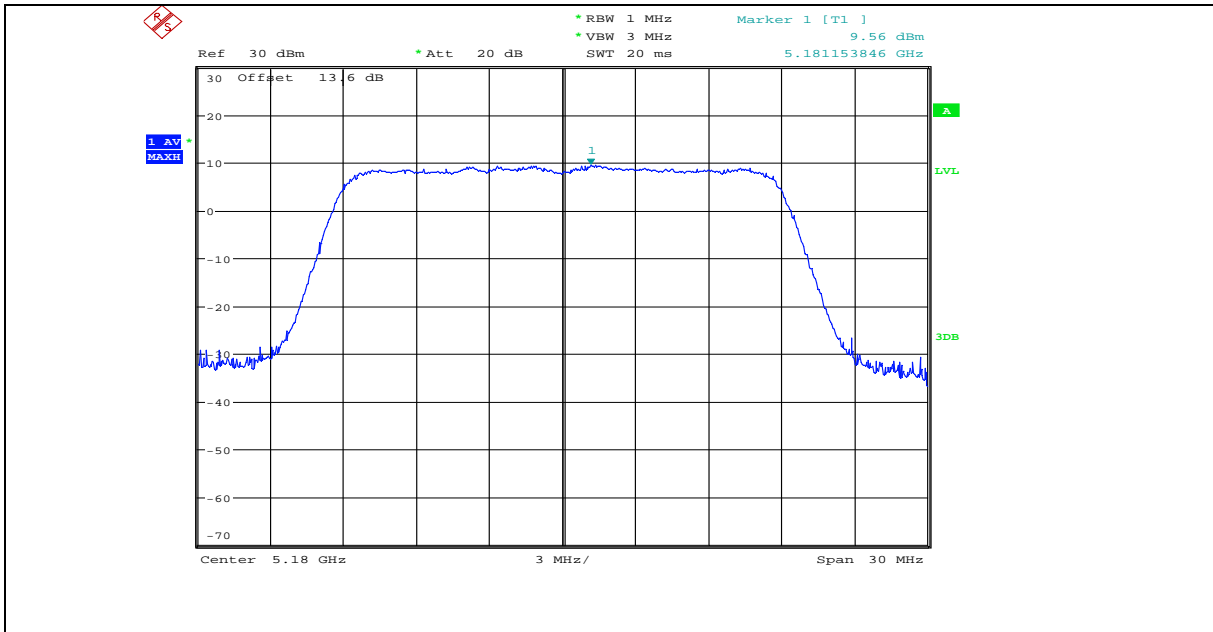

11AC20MIMO\_ANT2\_5180

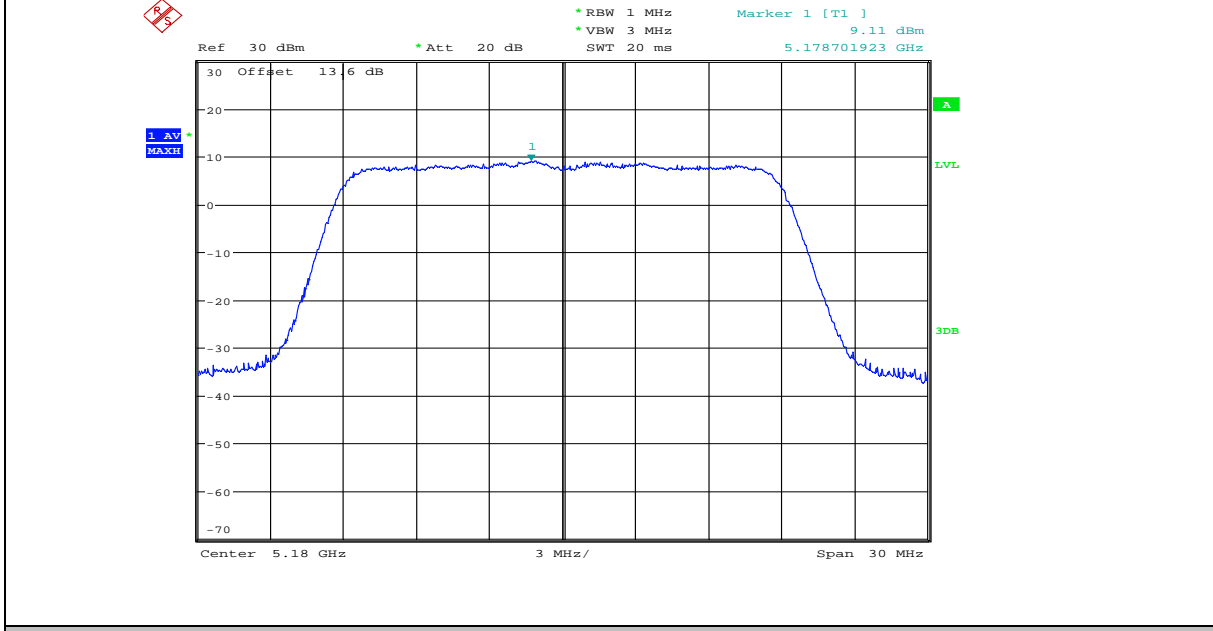

11AC20MIMO\_ANT3\_5180

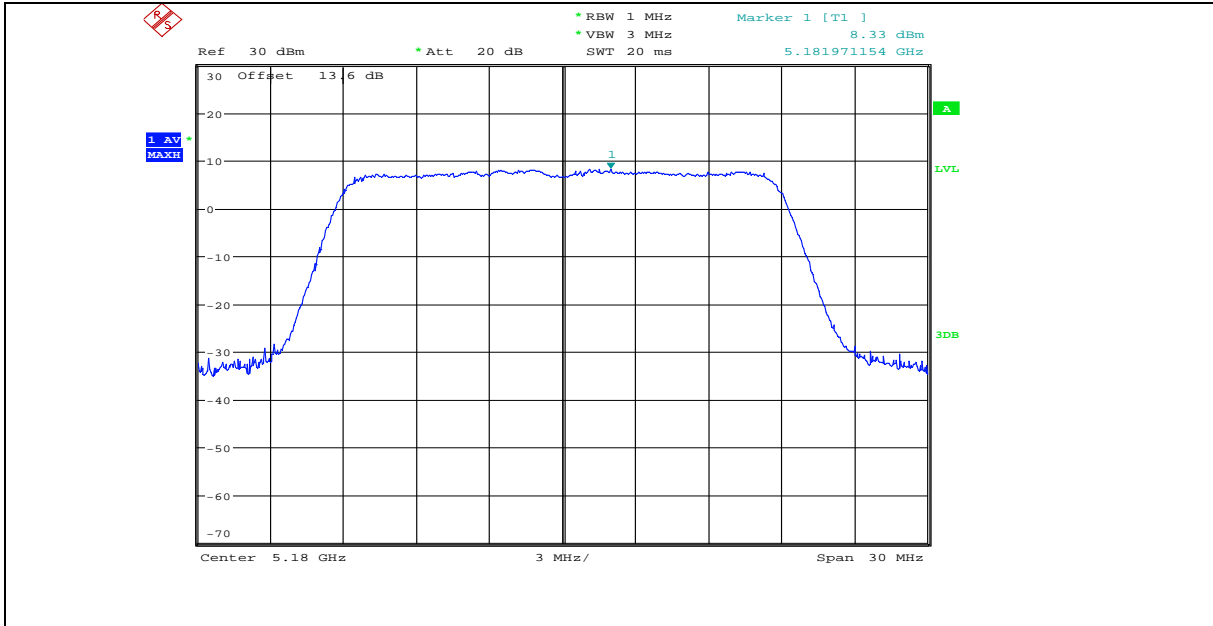

11AC20MIMO\_ANT1\_5200

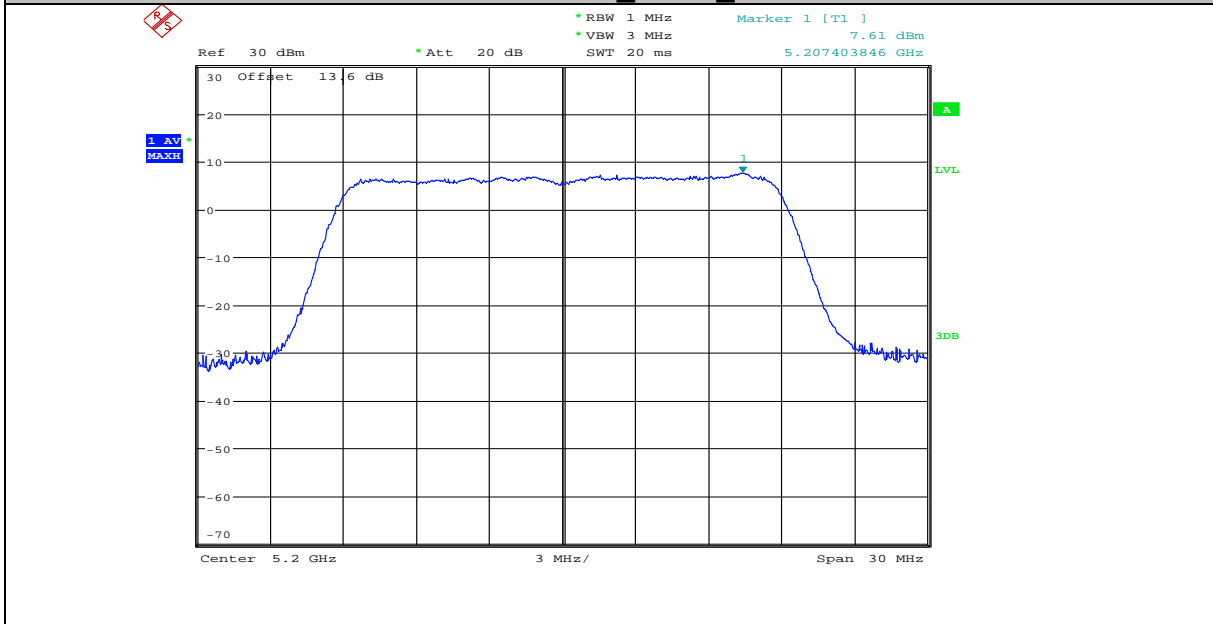

11AC20MIMO\_ANT2\_5200

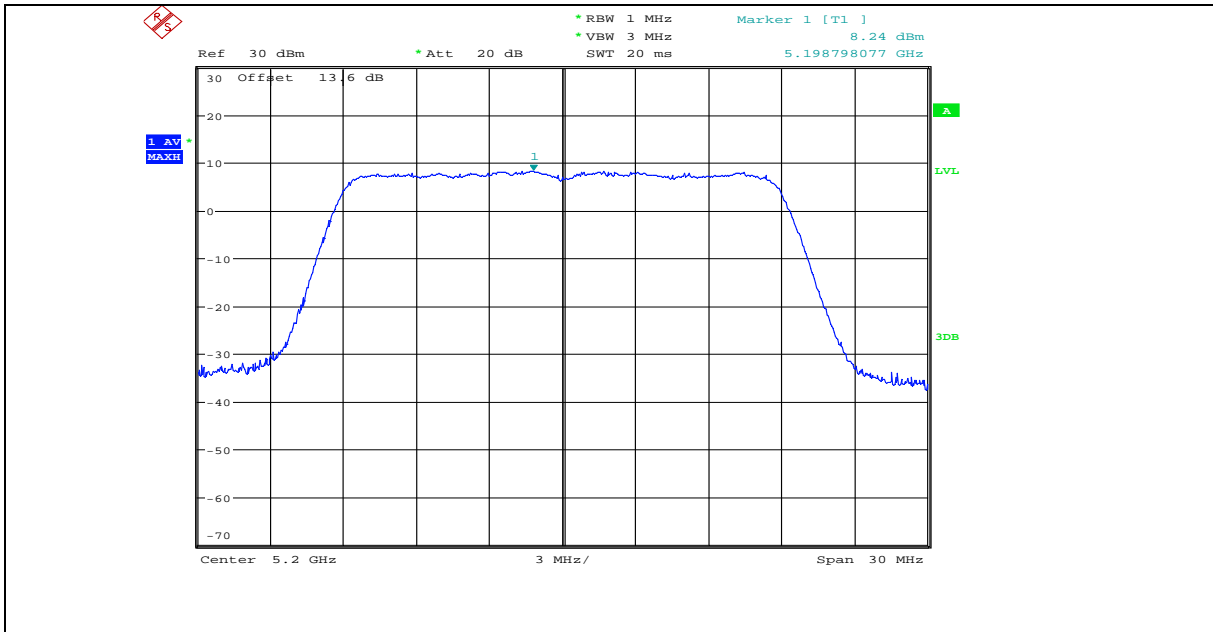

11AC20MIMO\_ANT3\_5200

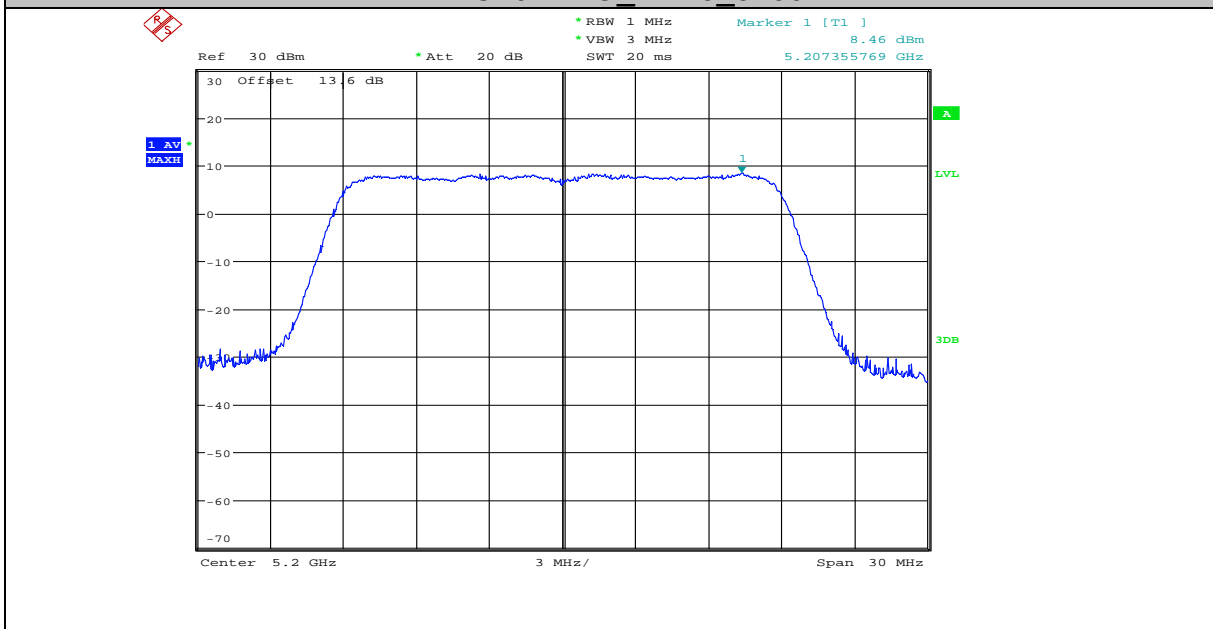

11AC20MIMO\_ANT1\_5240

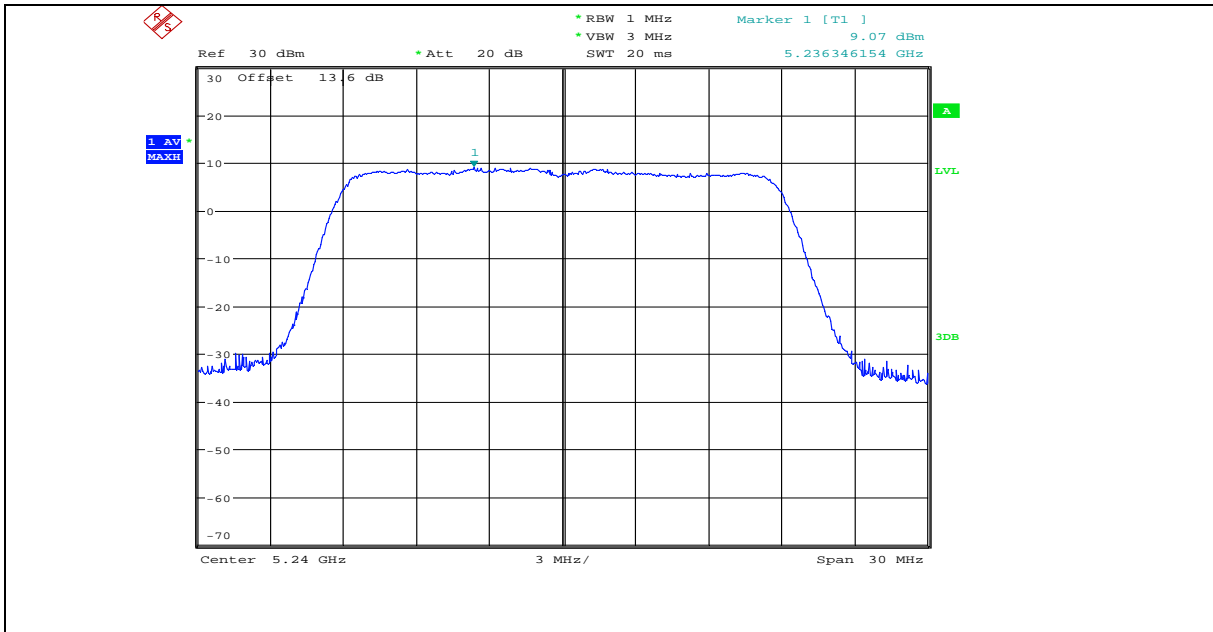

11AC20MIMO ANT2 5240

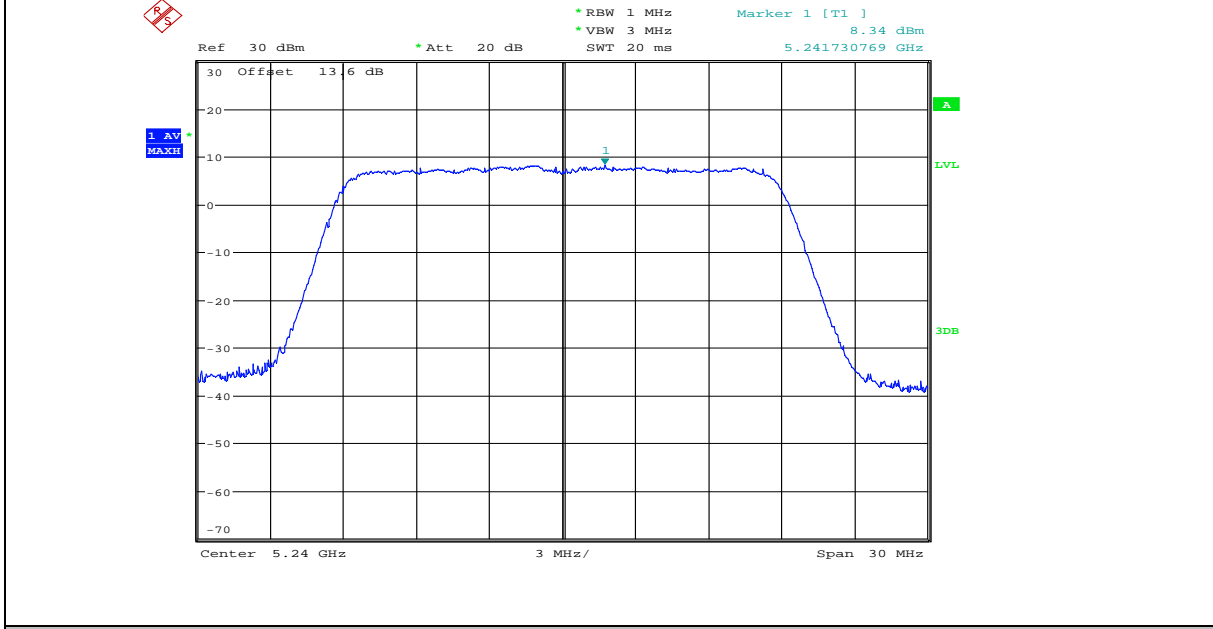

11AC20MIMO ANT3 5240

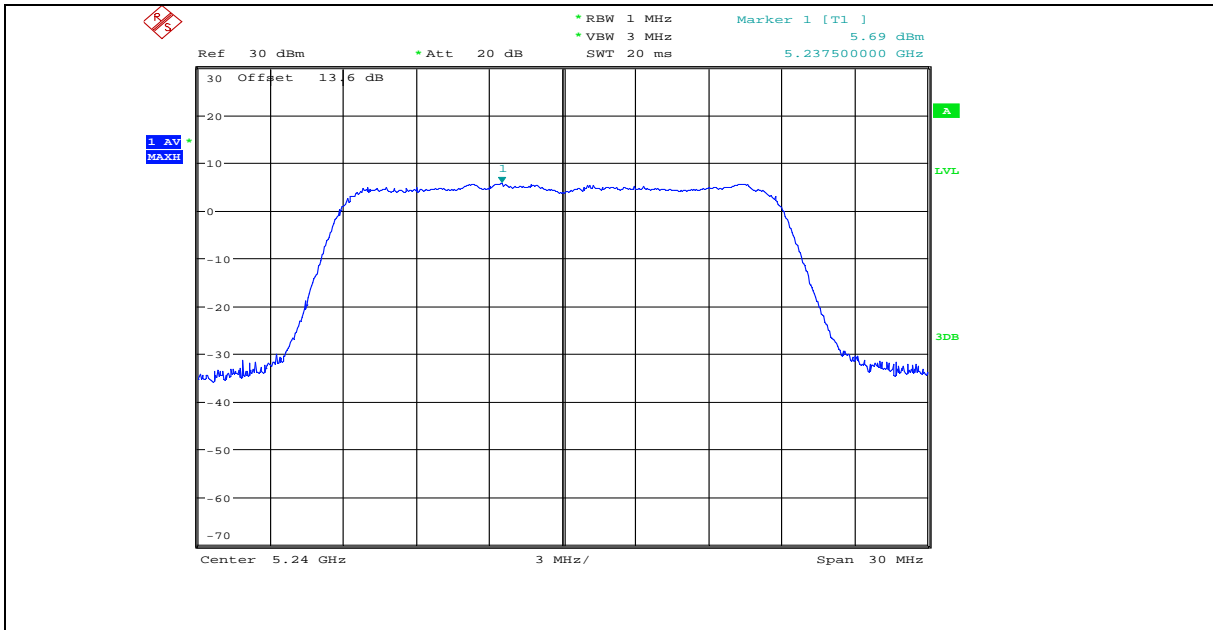

11AC20MIMO ANT1 5745

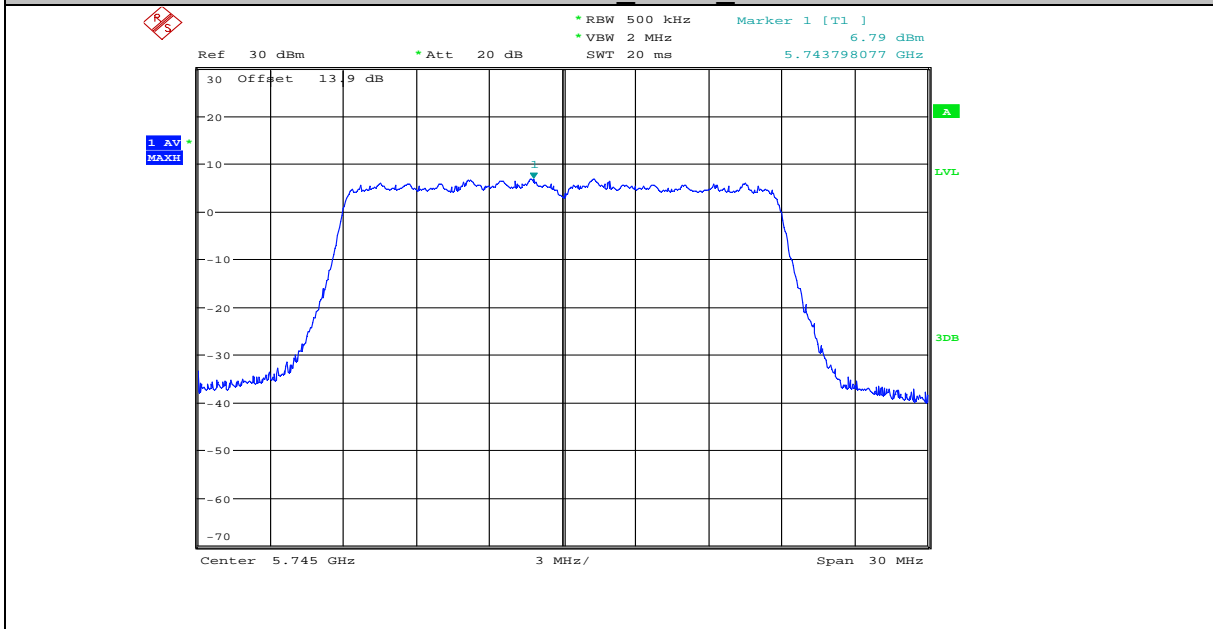

11AC20MIMO ANT2 5745



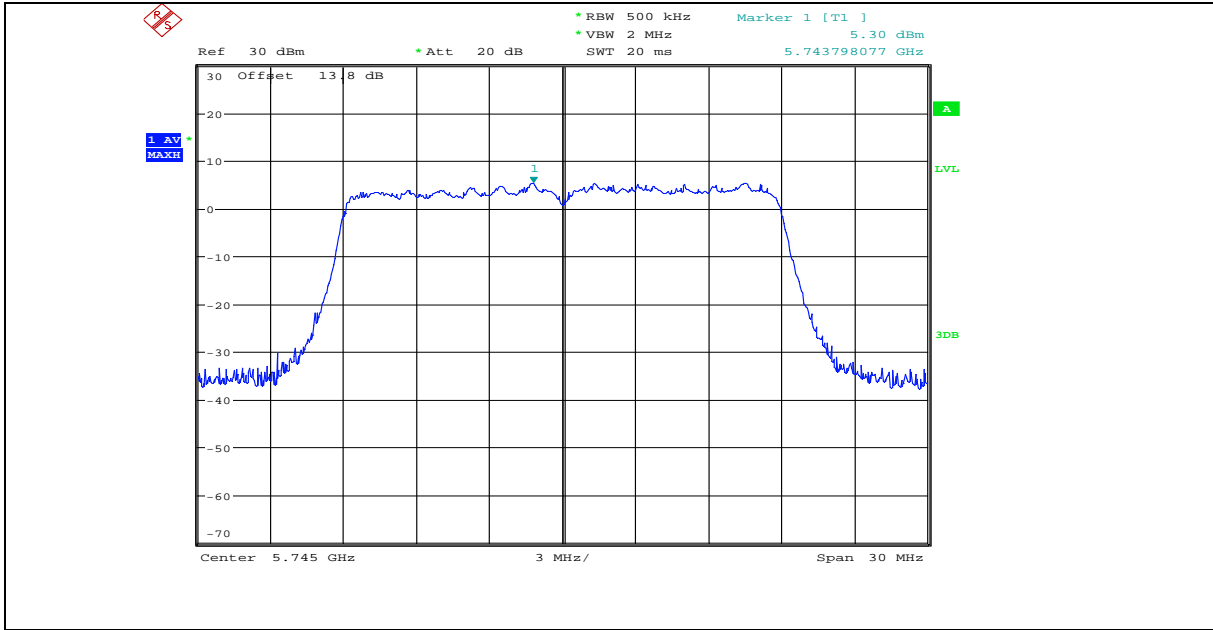

11AC20MIMO ANT3 5745

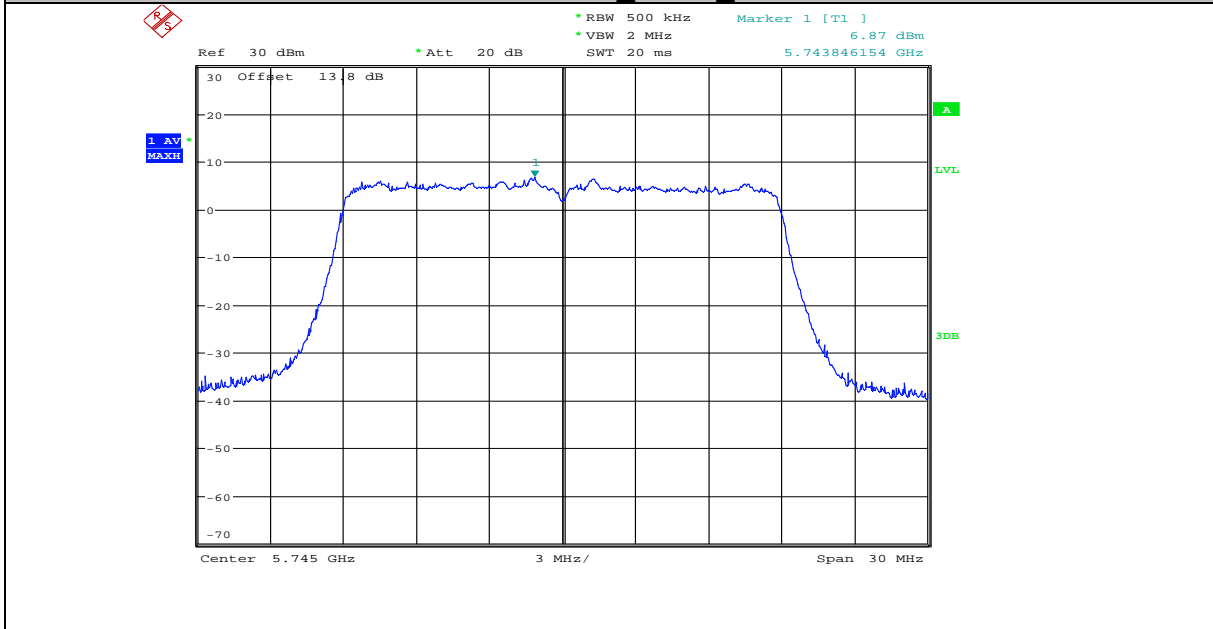

11AC20MIMO ANT1 5785

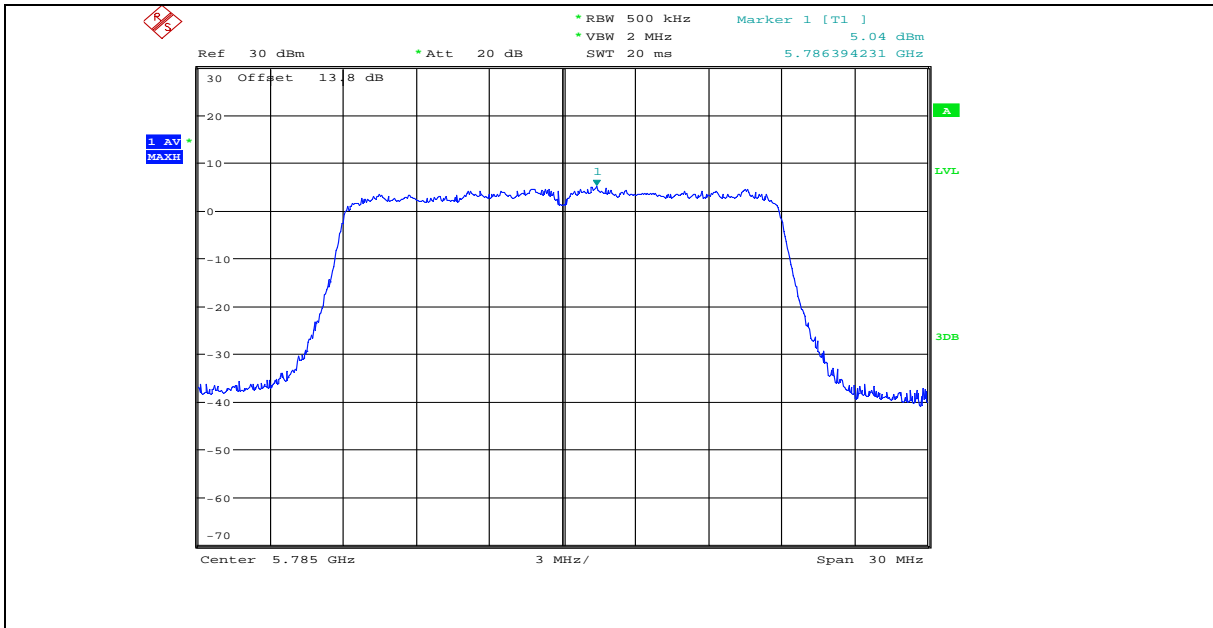

11AC20MIMO\_ANT2\_5785

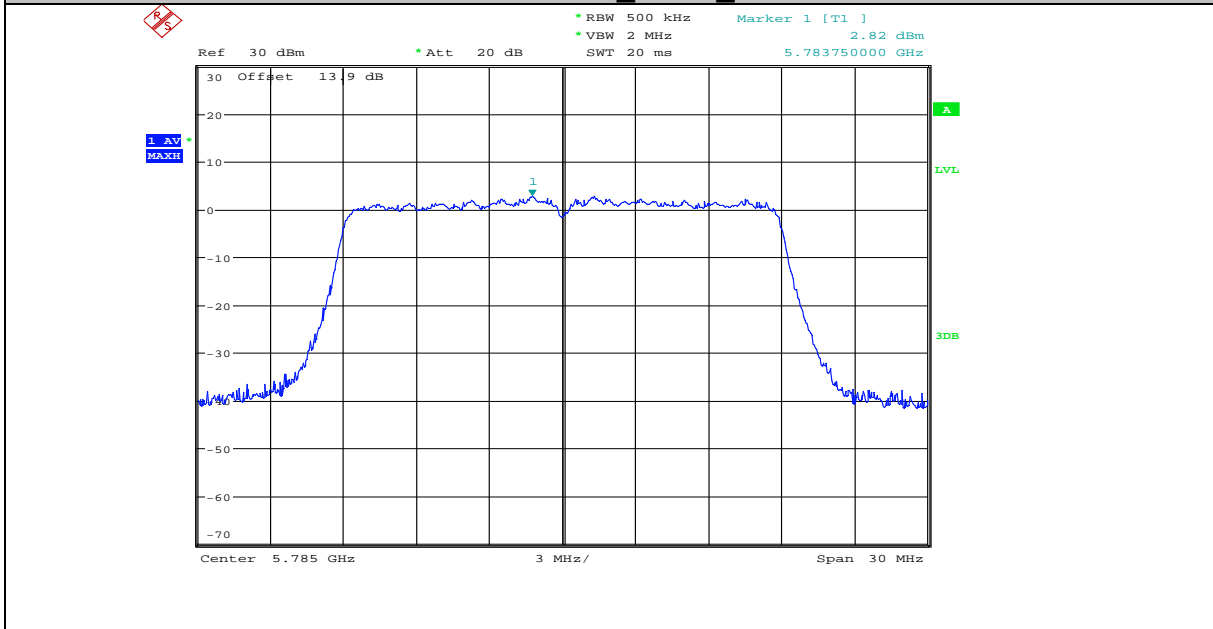

11AC20MIMO\_ANT3\_5785

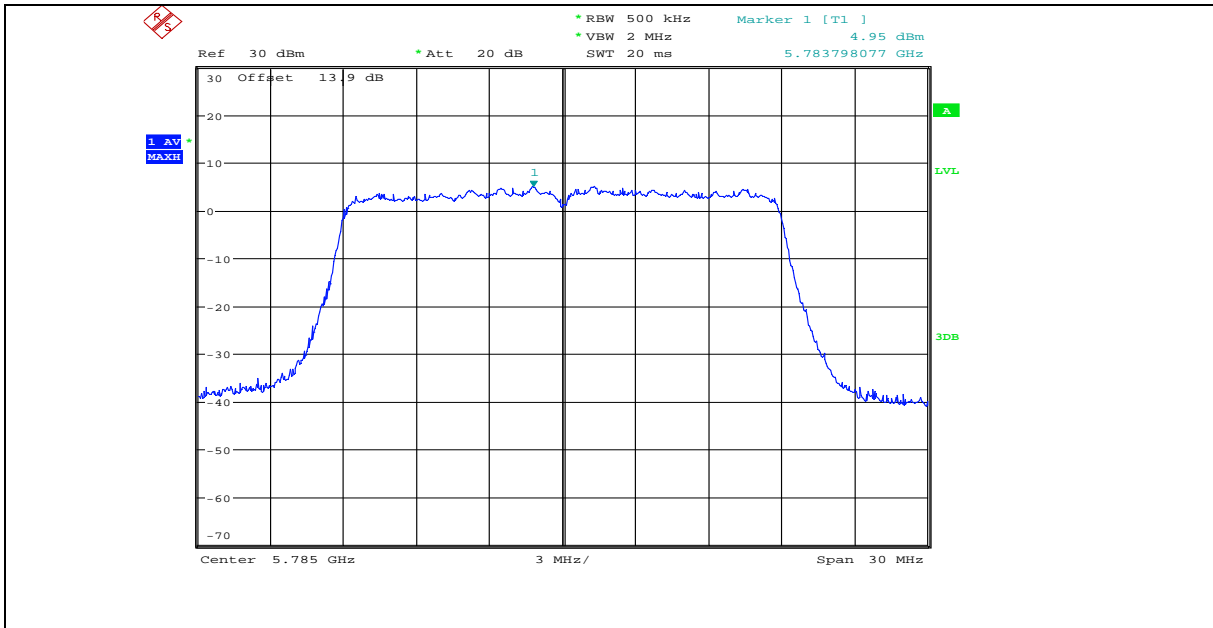

11AC20MIMO\_ANT1\_5825

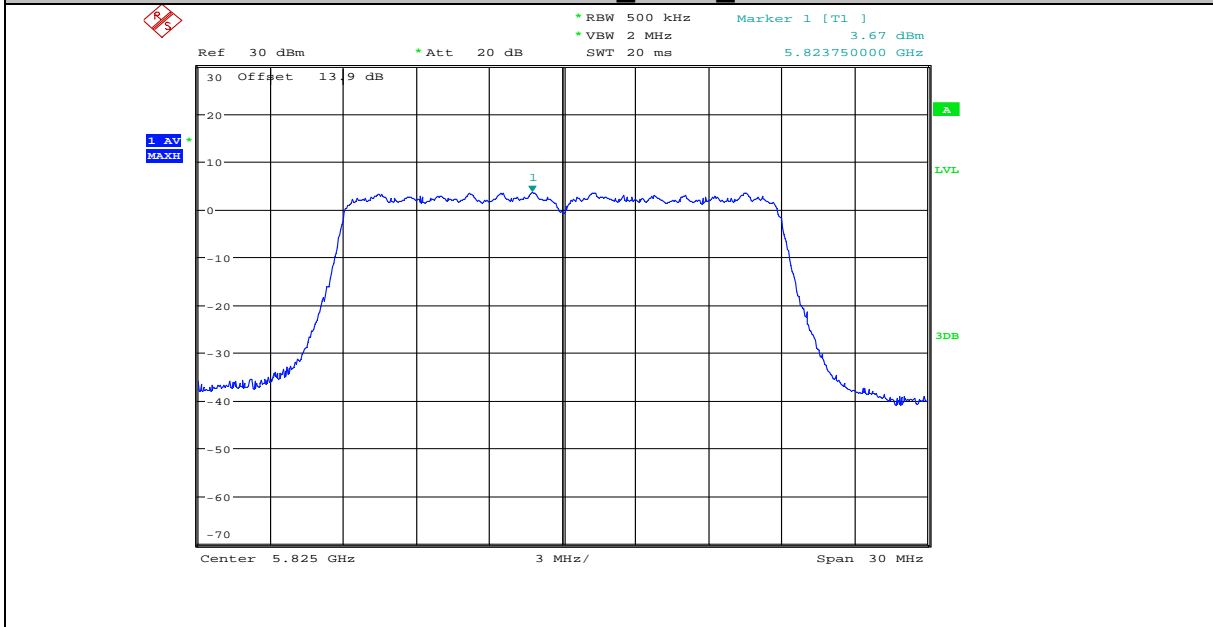

11AC20MIMO\_ANT2\_5825

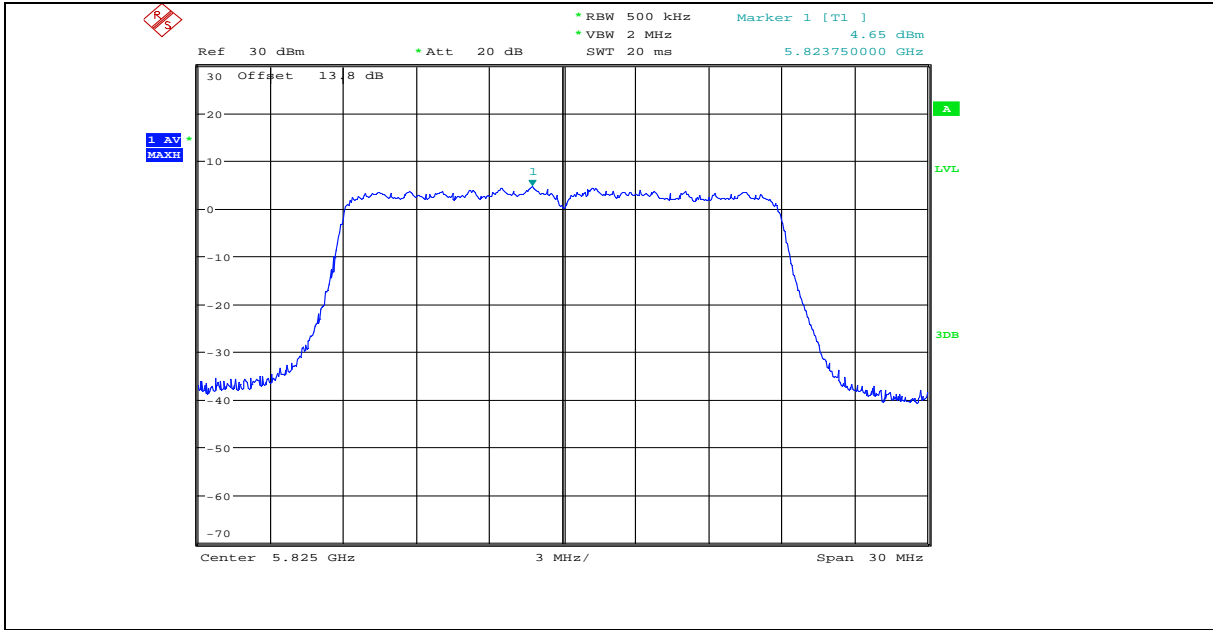

11AC20MIMO ANT3 5825

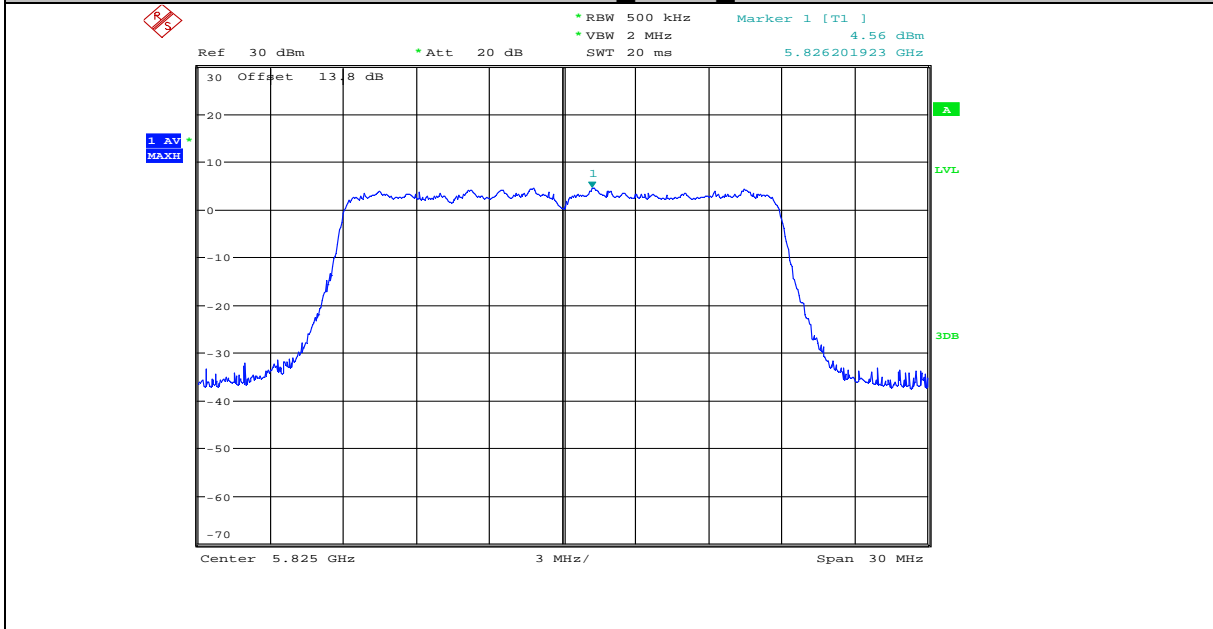

11AC40MIMO ANT1 5190

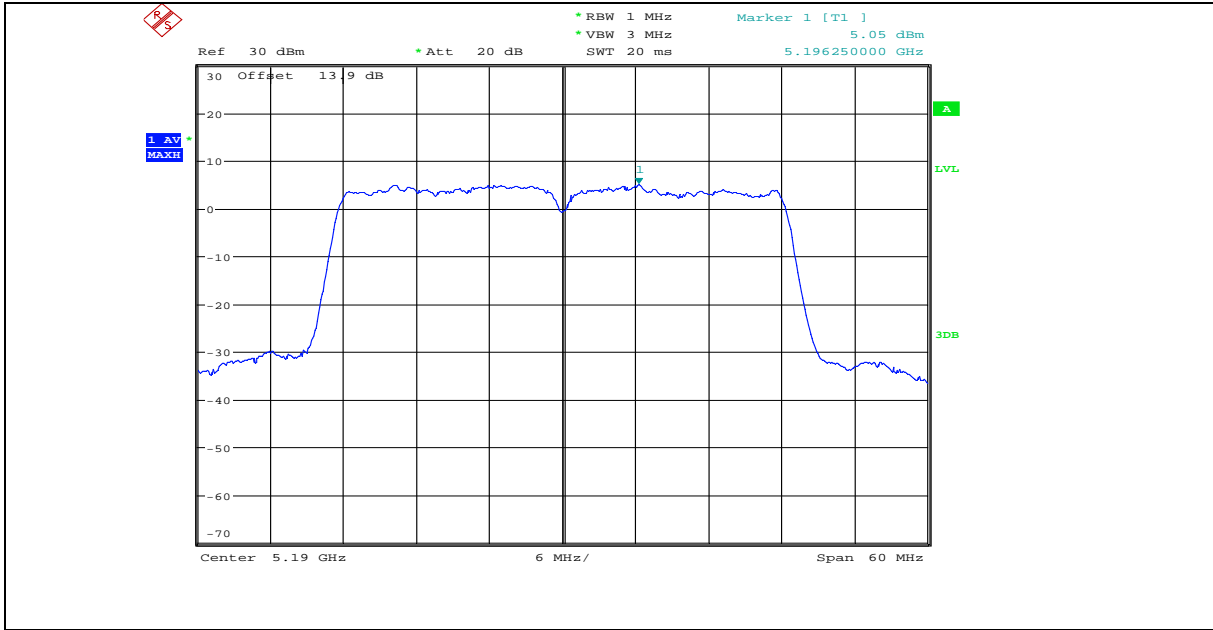

11AC40MIMO ANT2 5190

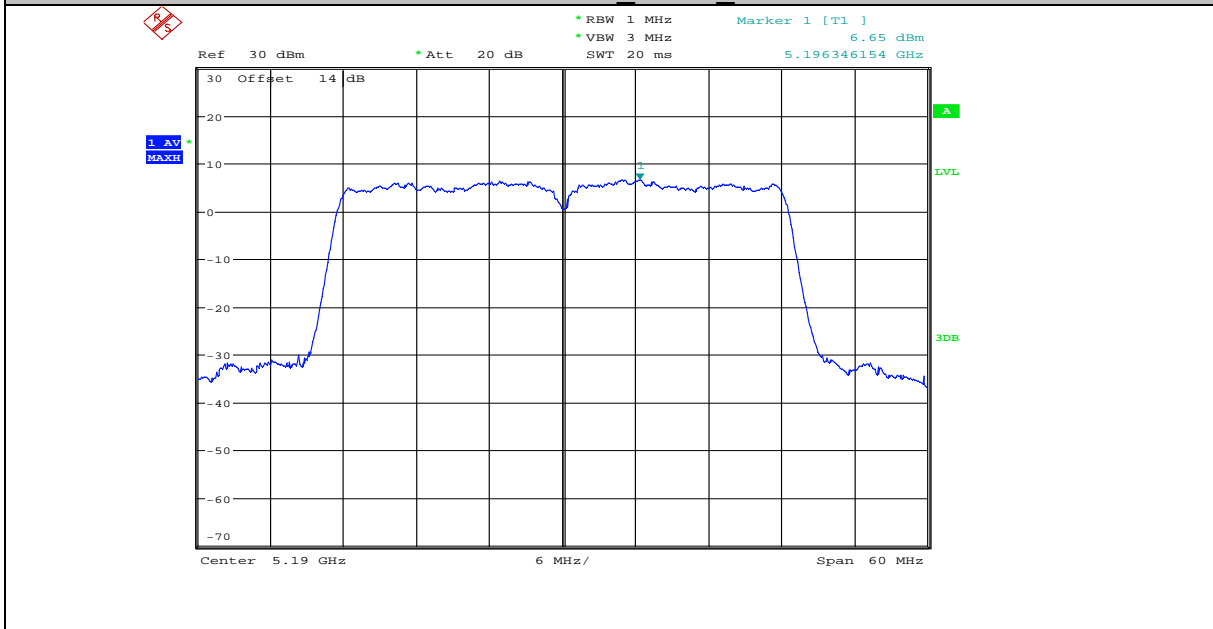

11AC40MIMO ANT3 5190

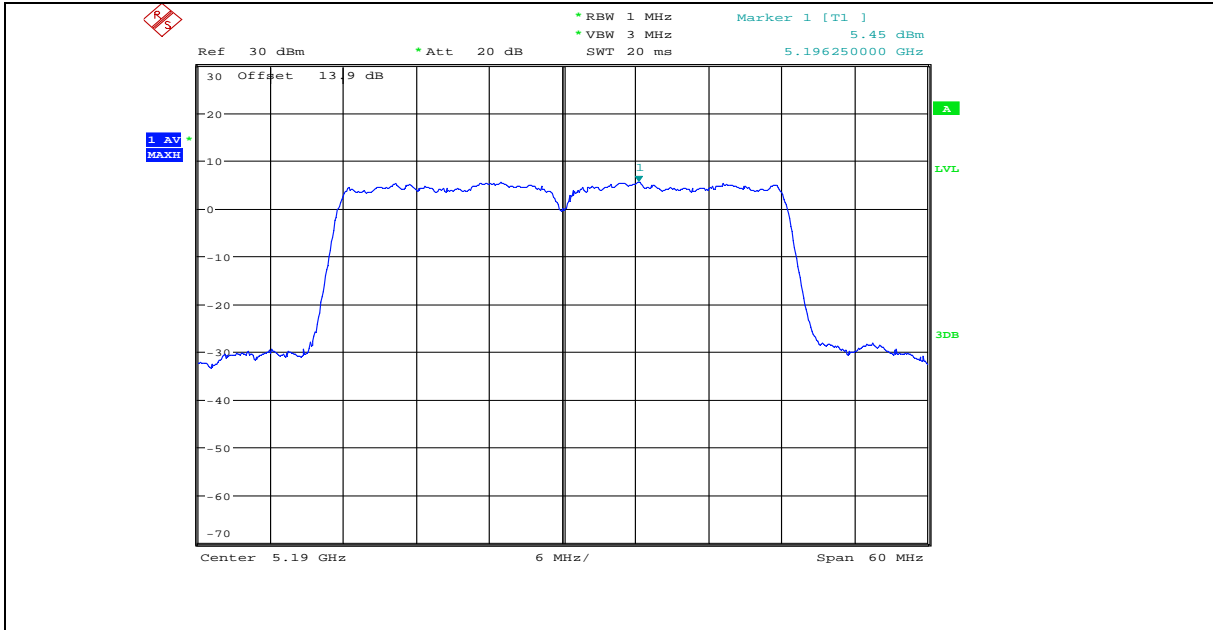

11AC40MIMO\_ANT1\_5230

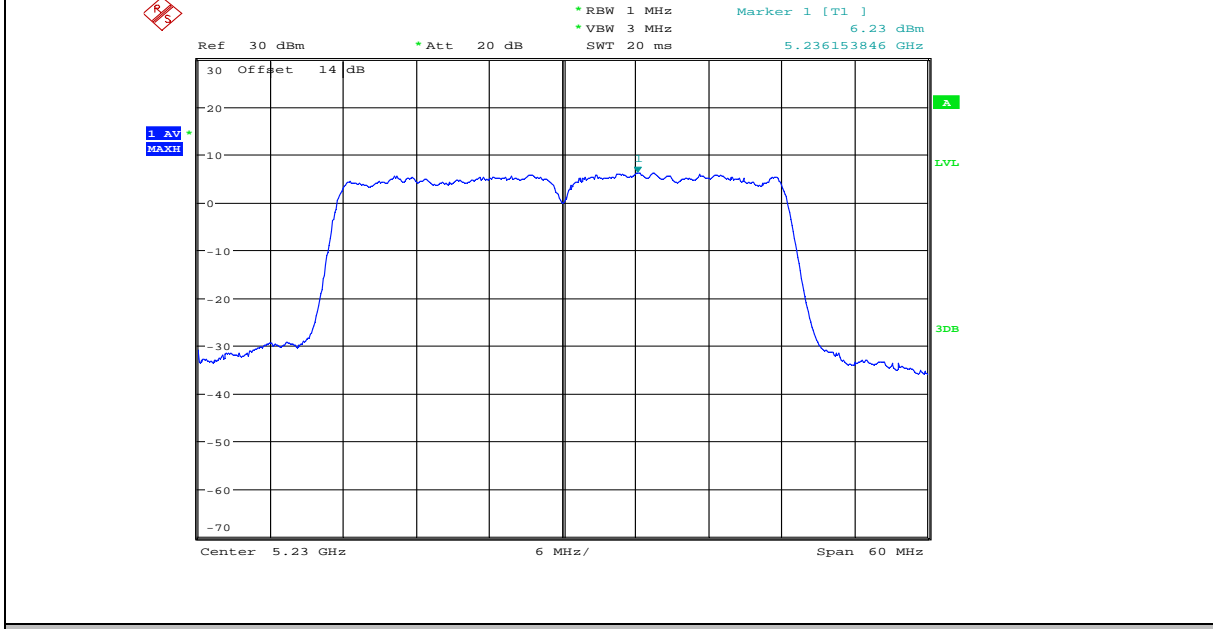

11AC40MIMO\_ANT2\_5230

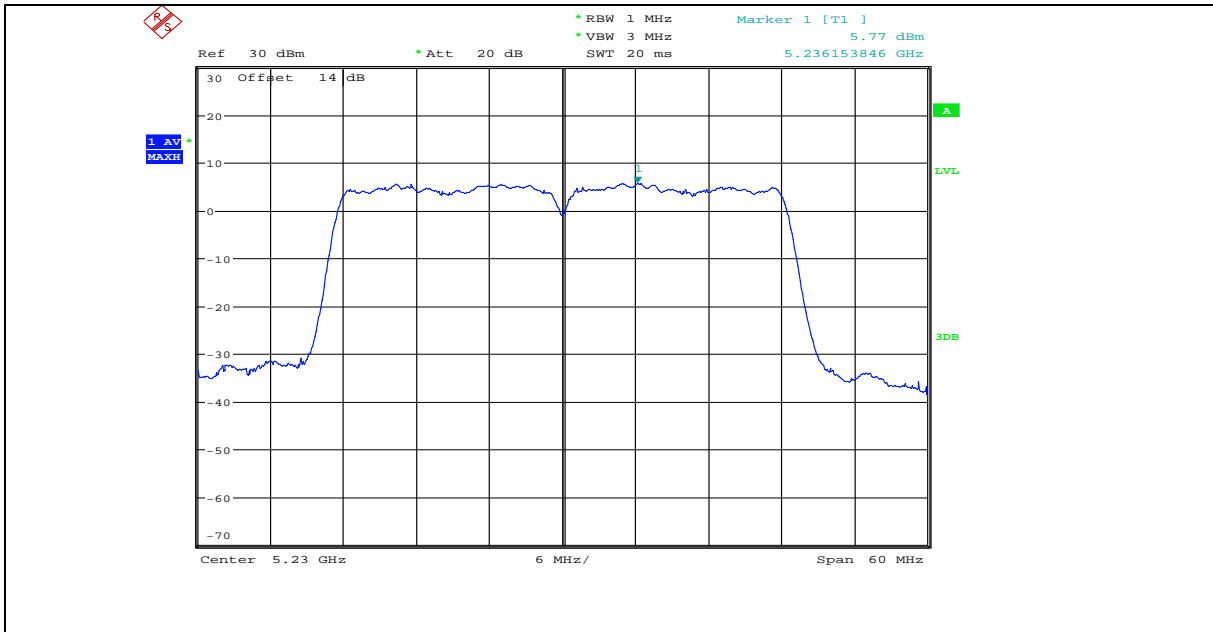

11AC40MIMO\_ANT3\_5230

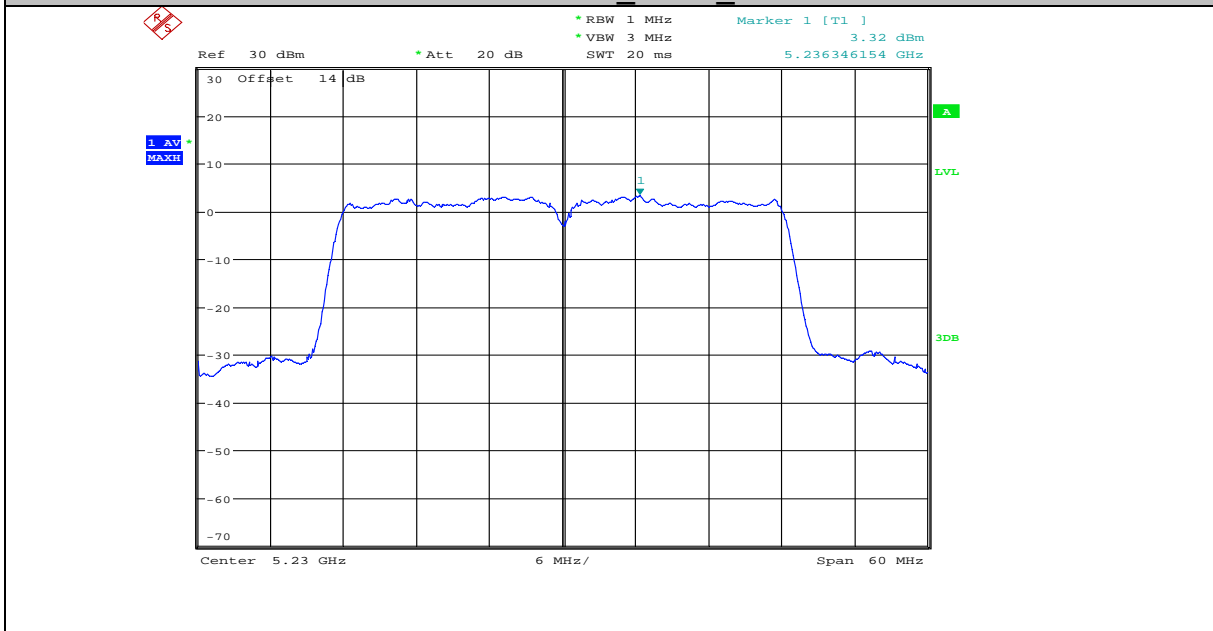

11AC40MIMO\_ANT1\_5755

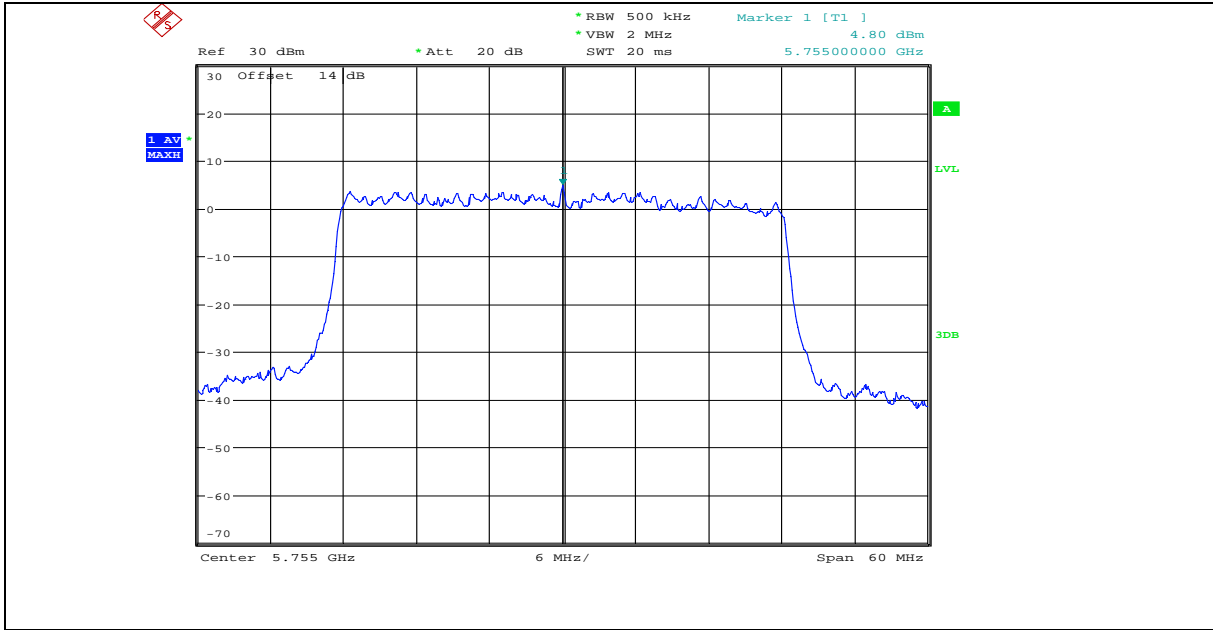

11AC40MIMO ANT2 5755

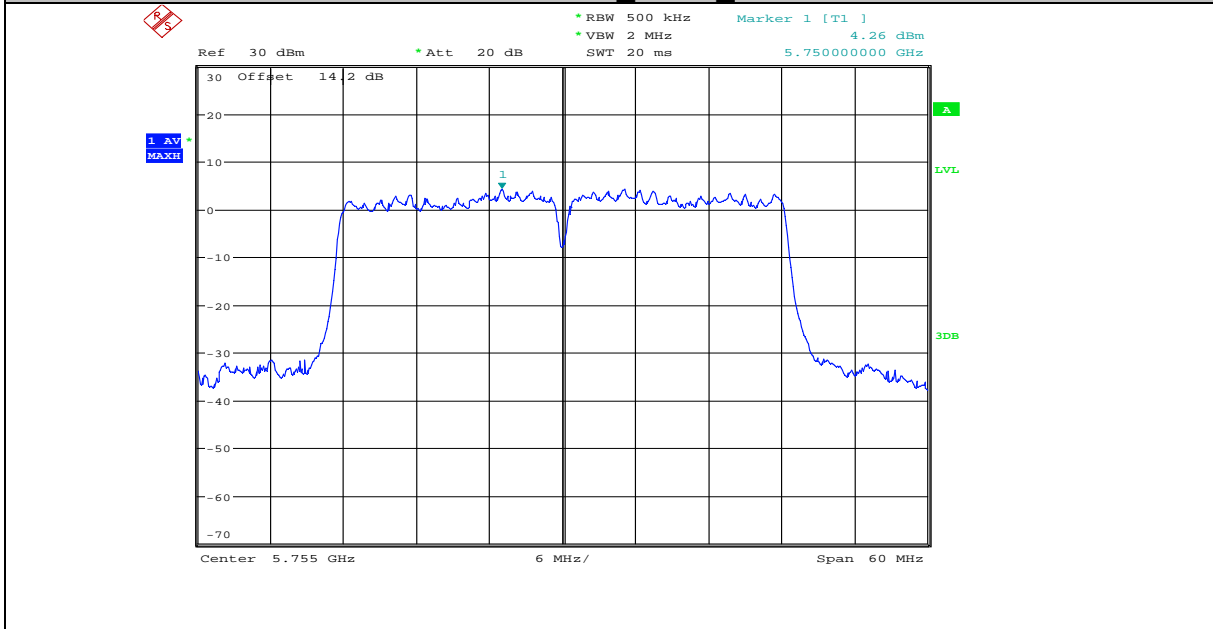

11AC40MIMO ANT3 5755



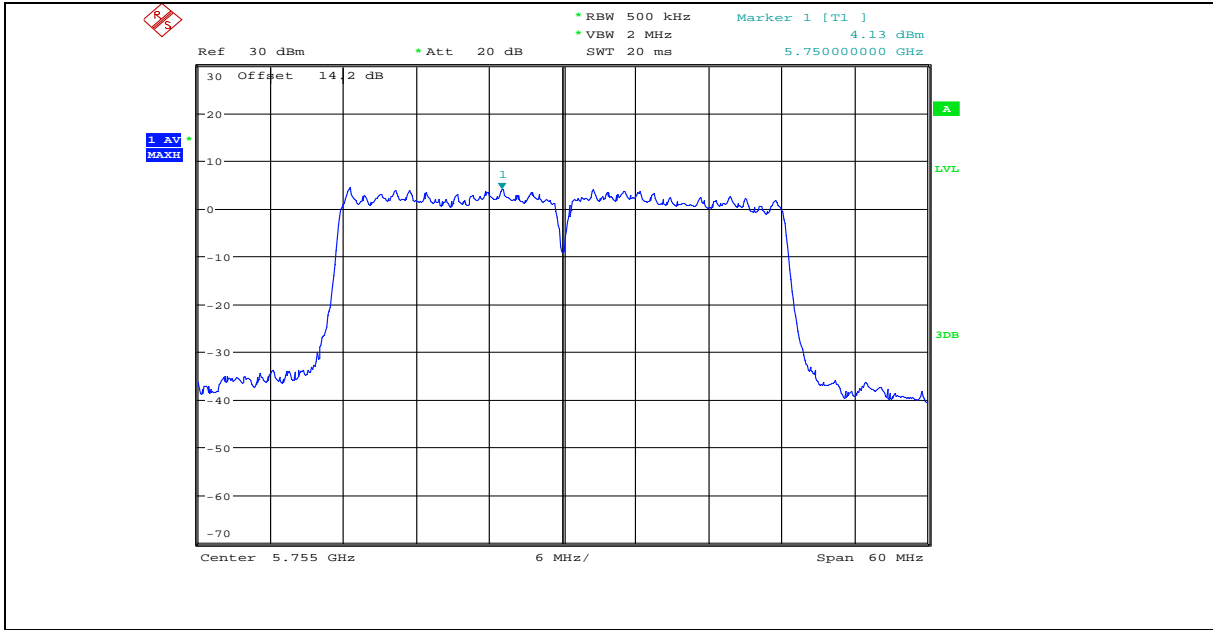

11AC40MIMO ANT1 5795

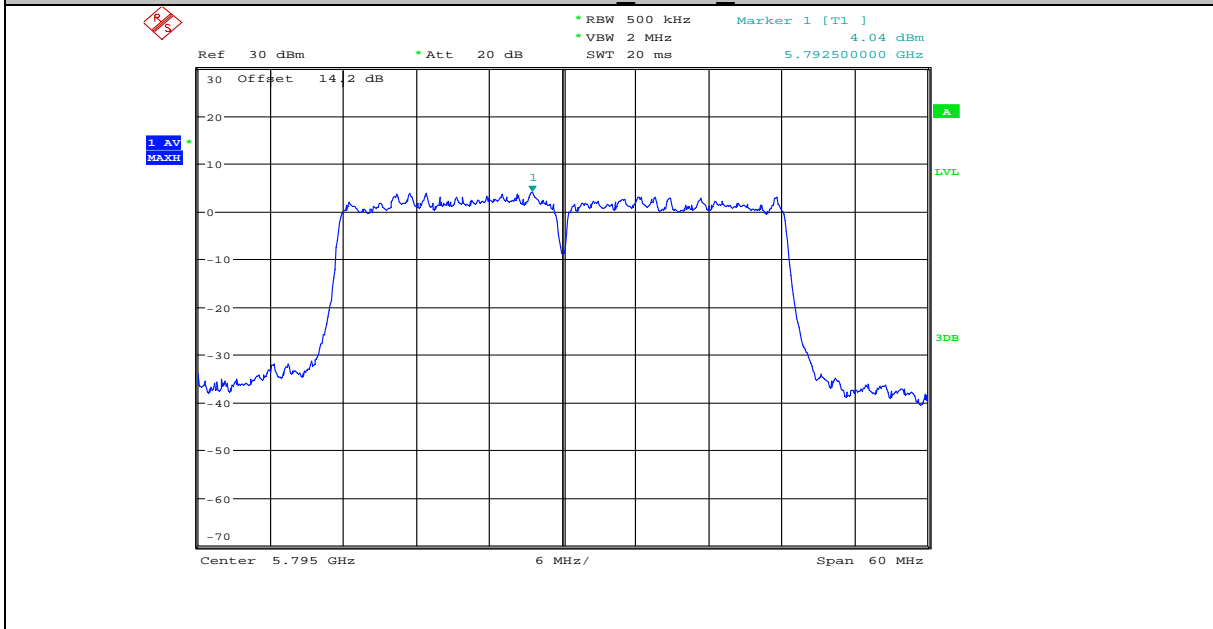

11AC40MIMO ANT2 5795

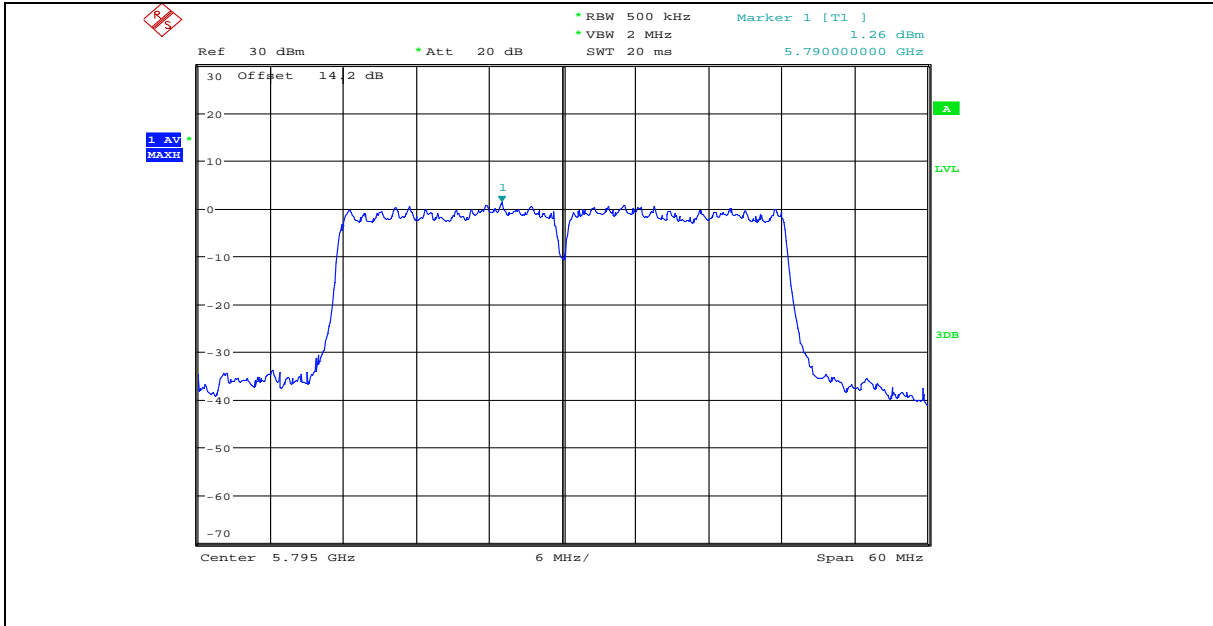

11AC40MIMO\_ANT3\_5795

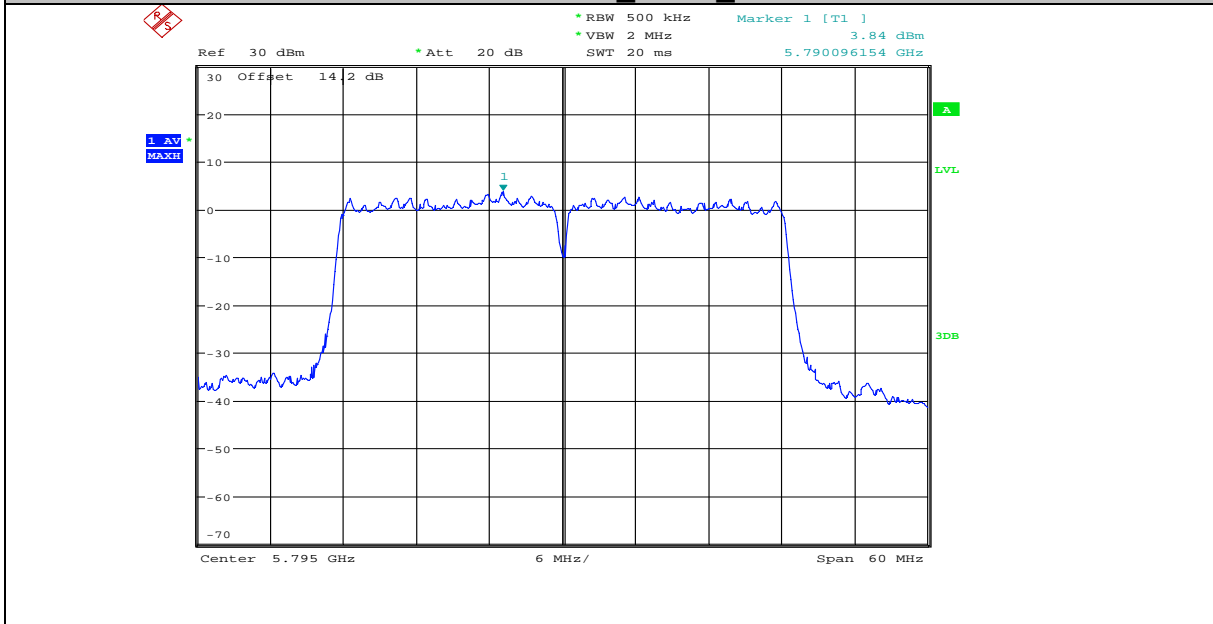

11AC80MIMO\_ANT1\_5210

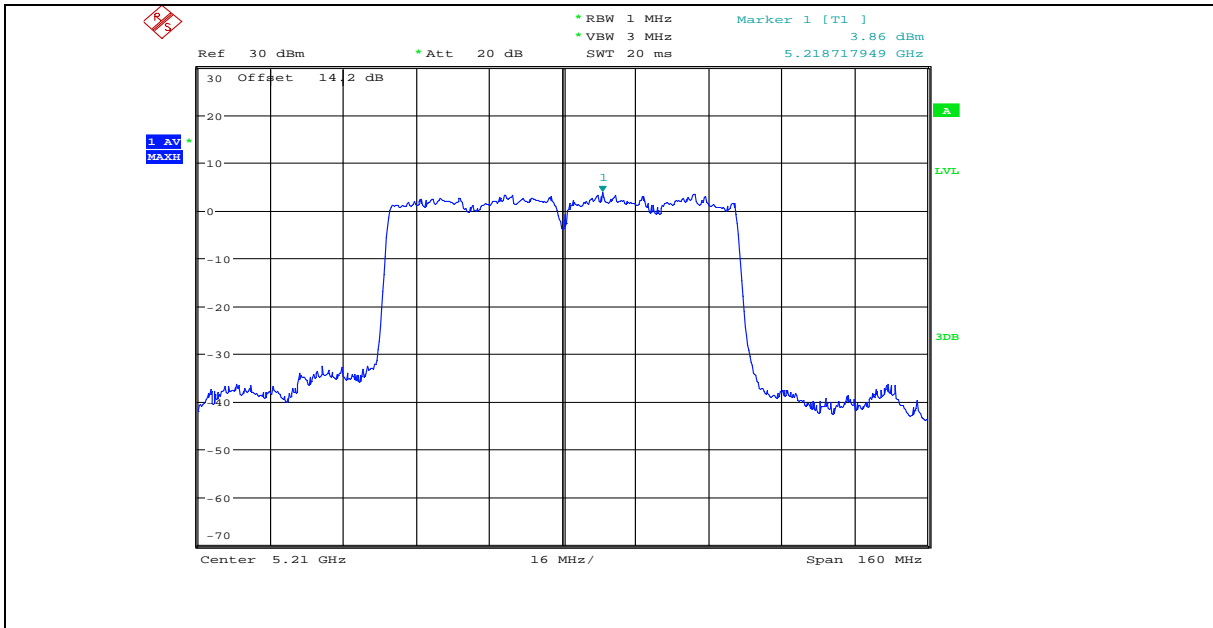

11AC80MIMO\_ANT2\_5210

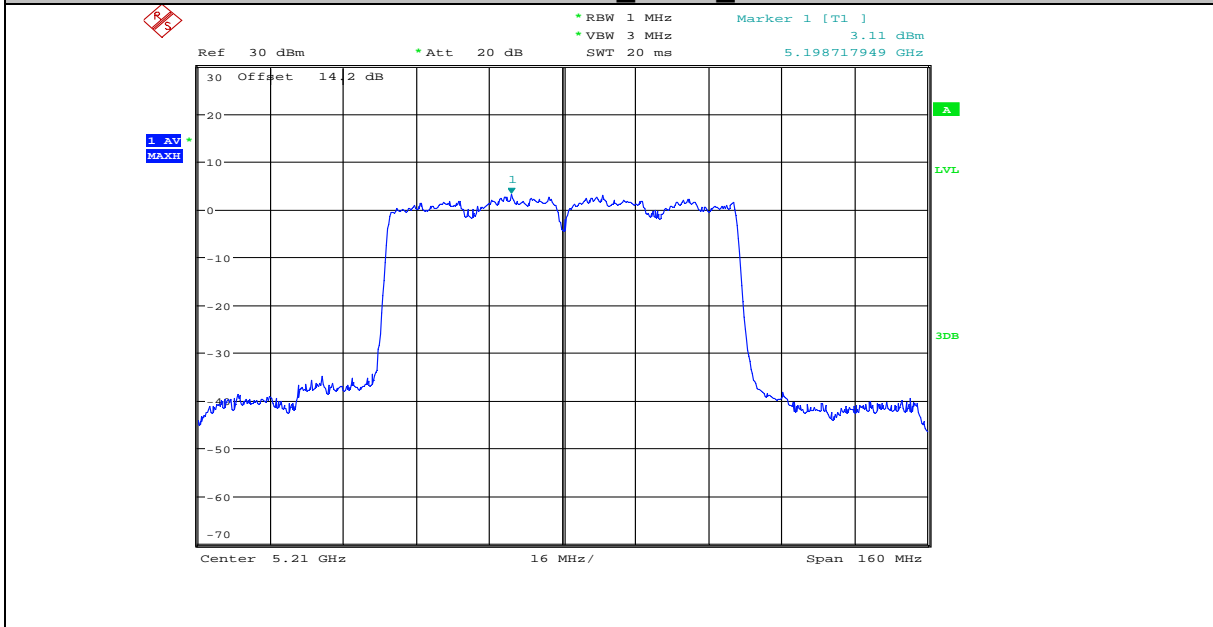

11AC80MIMO\_ANT3\_5210

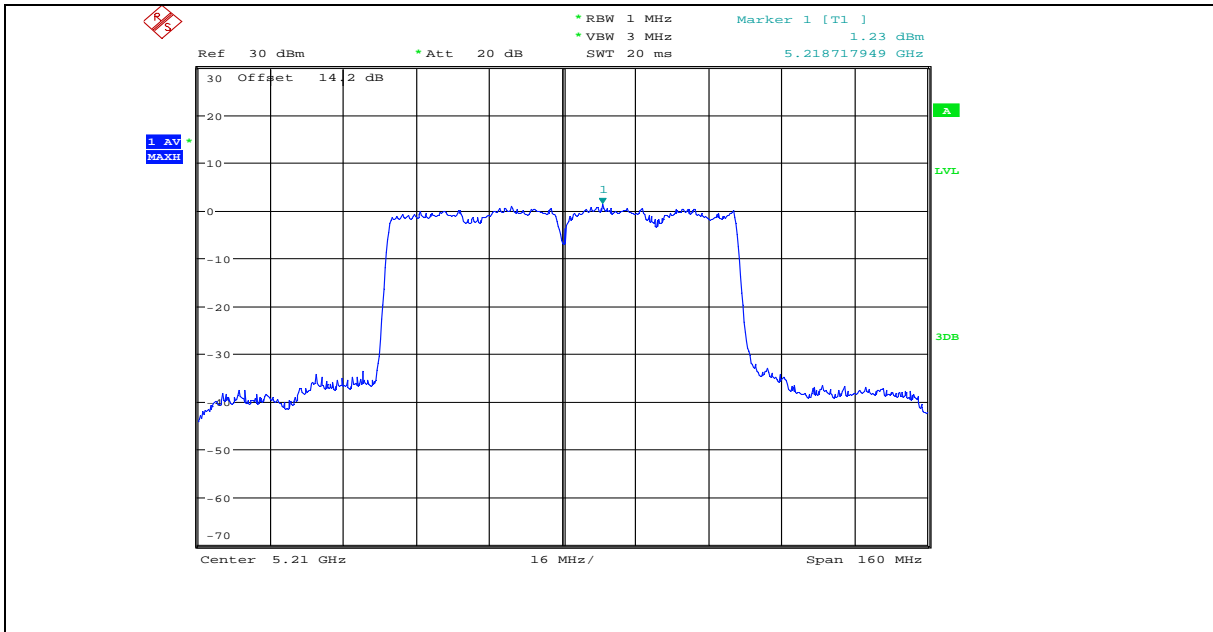

11AC80MIMO\_ANT1\_5775

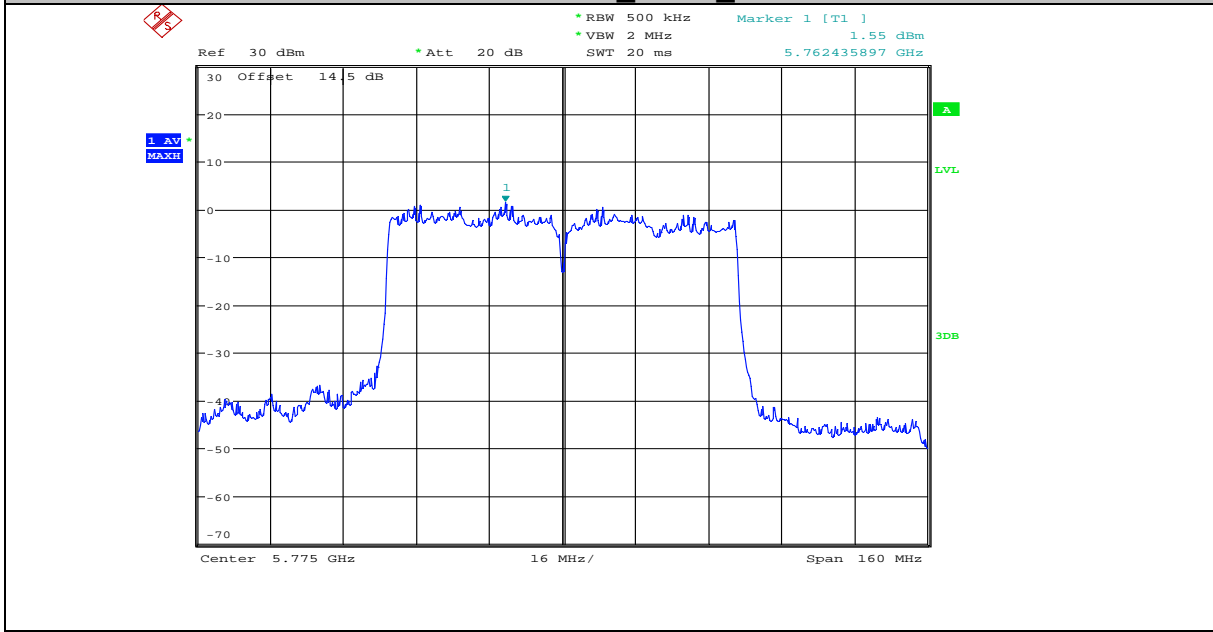

11AC80MIMO\_ANT2\_5775

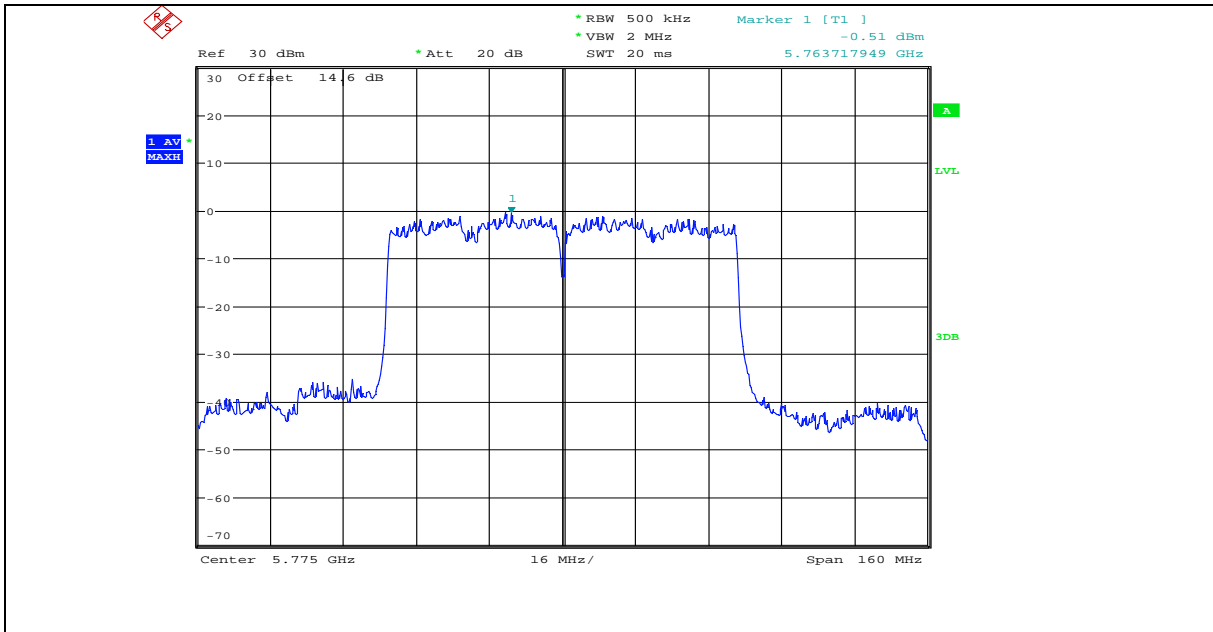

11AC80MIMO\_ANT3\_5775

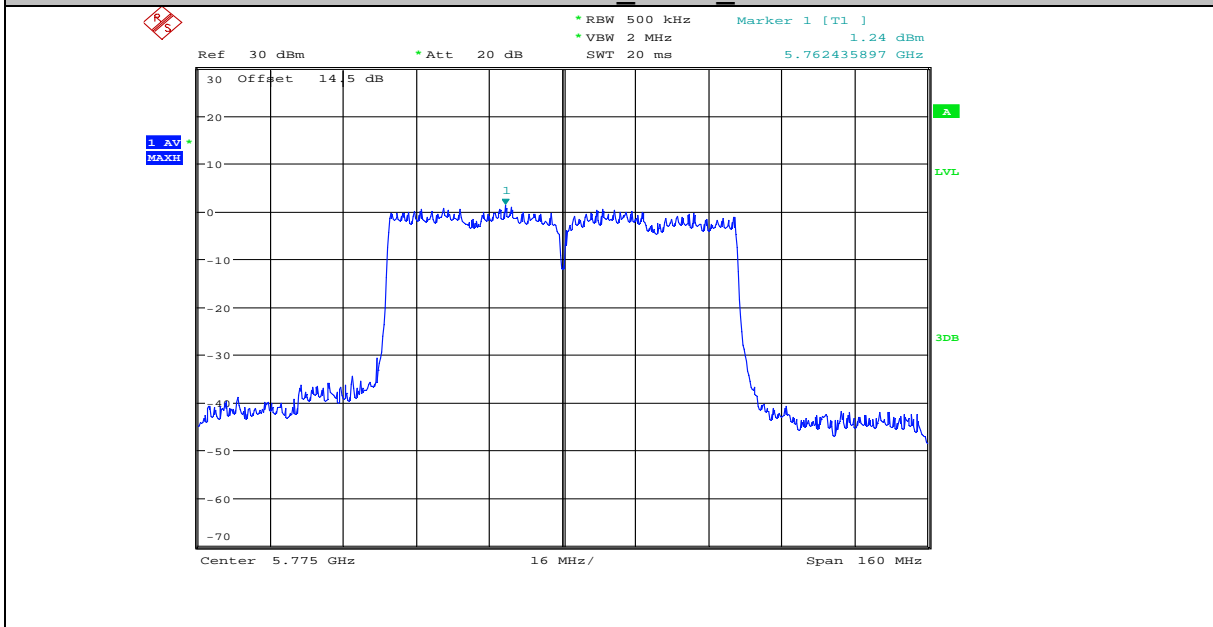

11ASISO\_ANT1\_5180

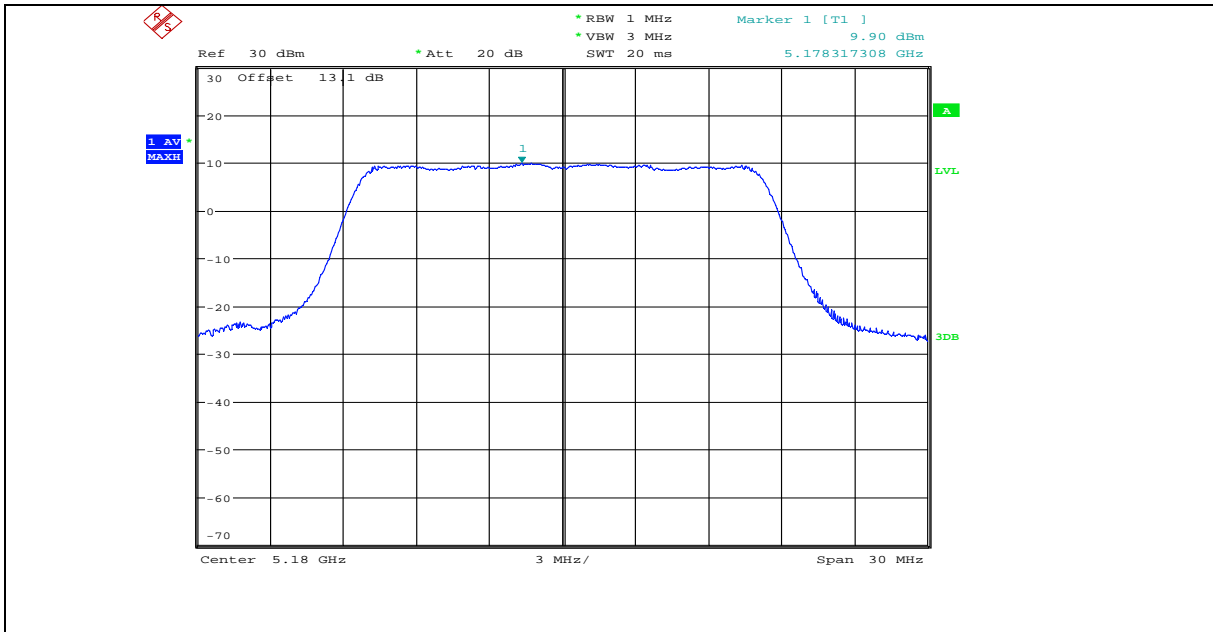

11ASISO\_ANT1\_5200

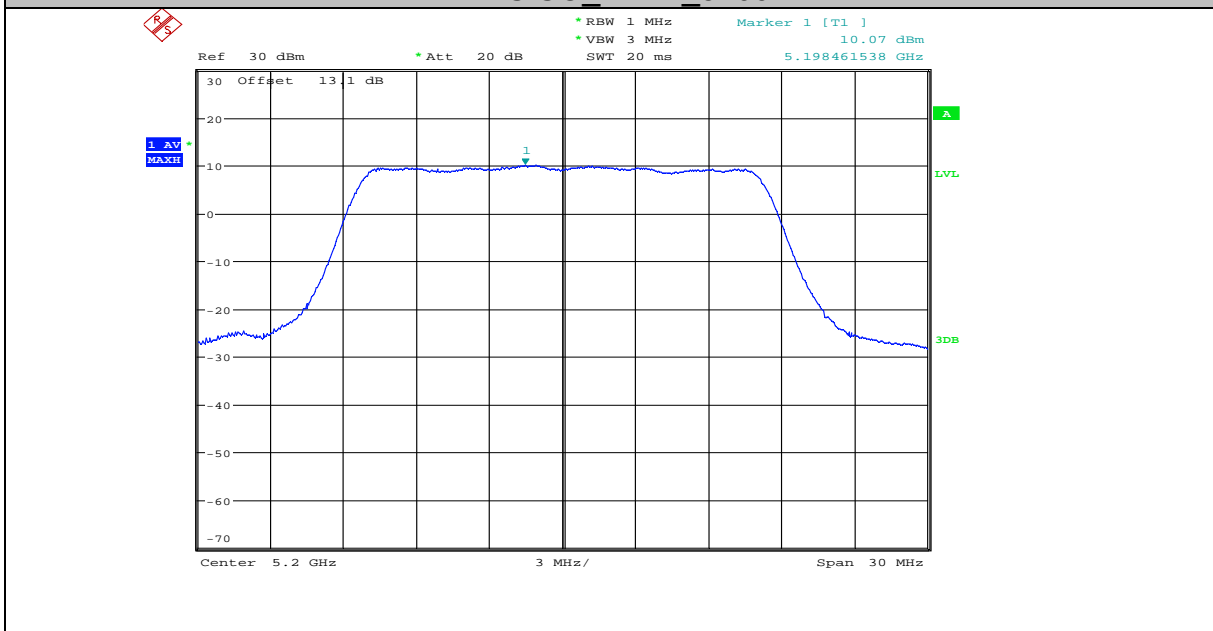

11ASISO\_ANT1\_5240

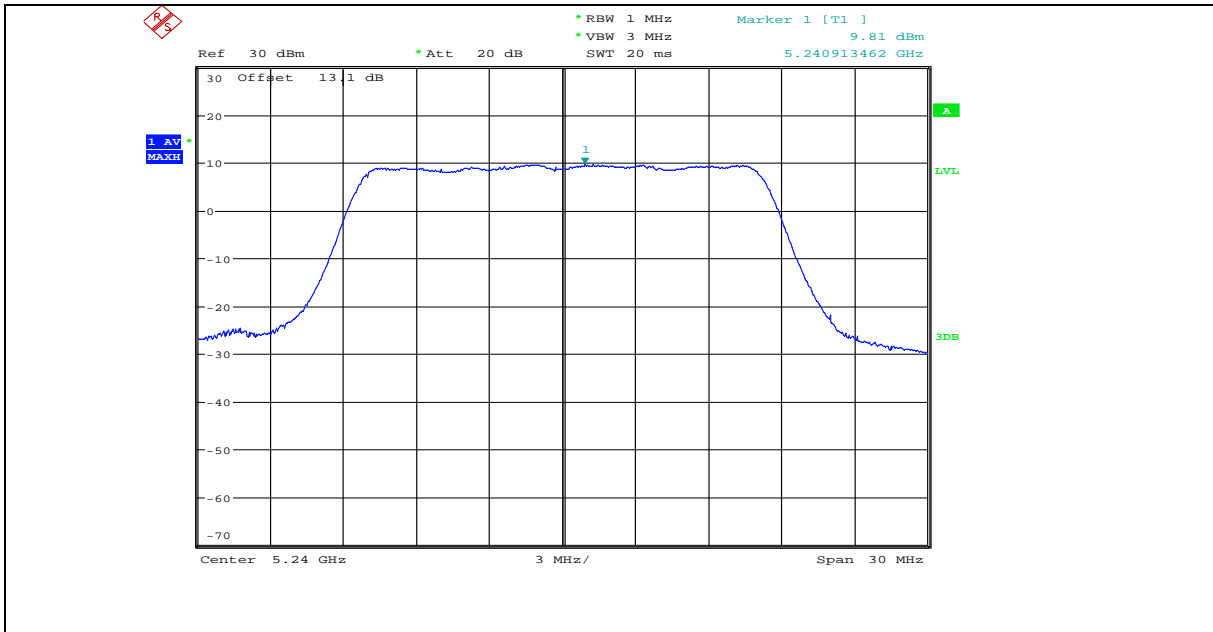

11ASISO ANT1\_5745

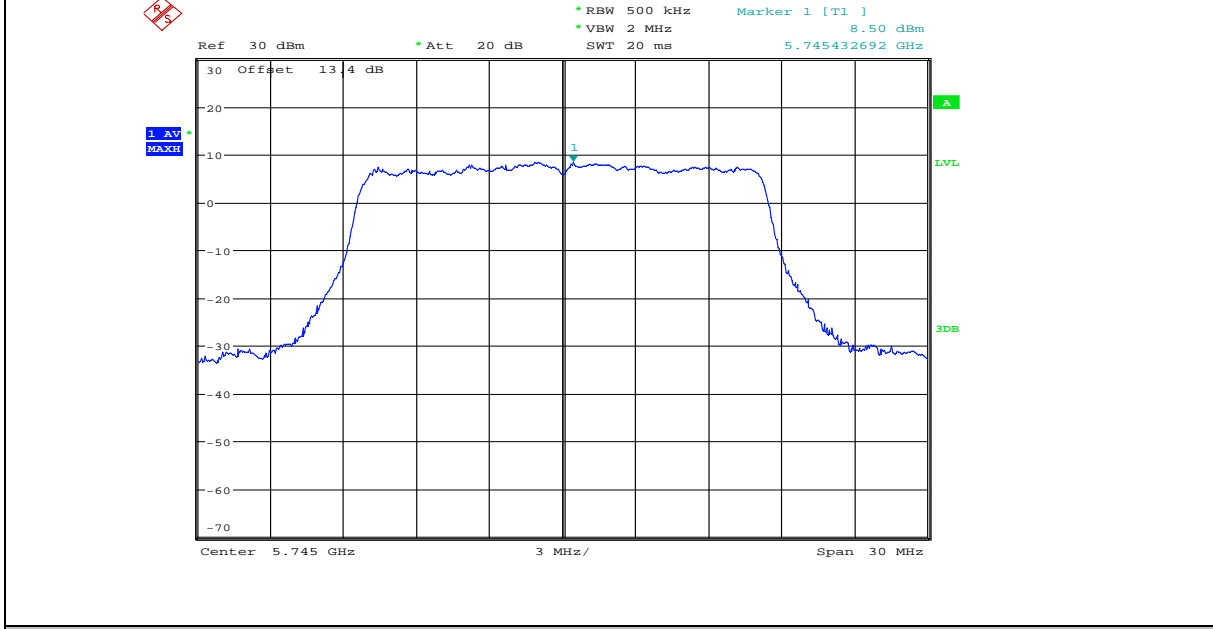

11ASISO ANT1\_5785

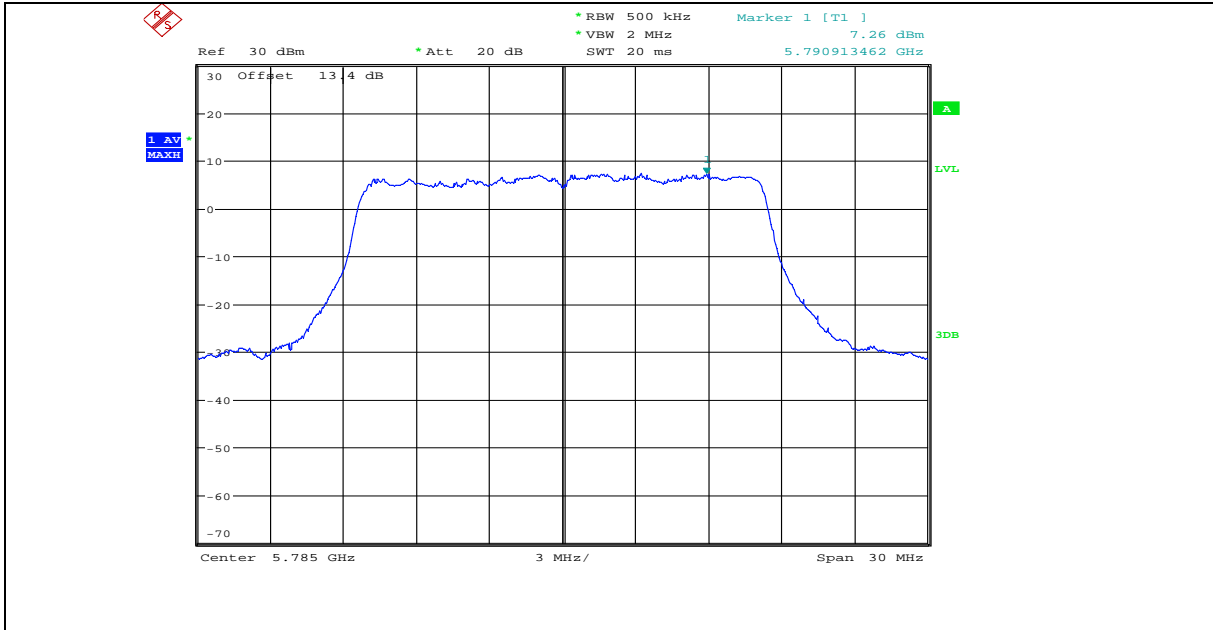

11ASISO\_ANT1\_5825

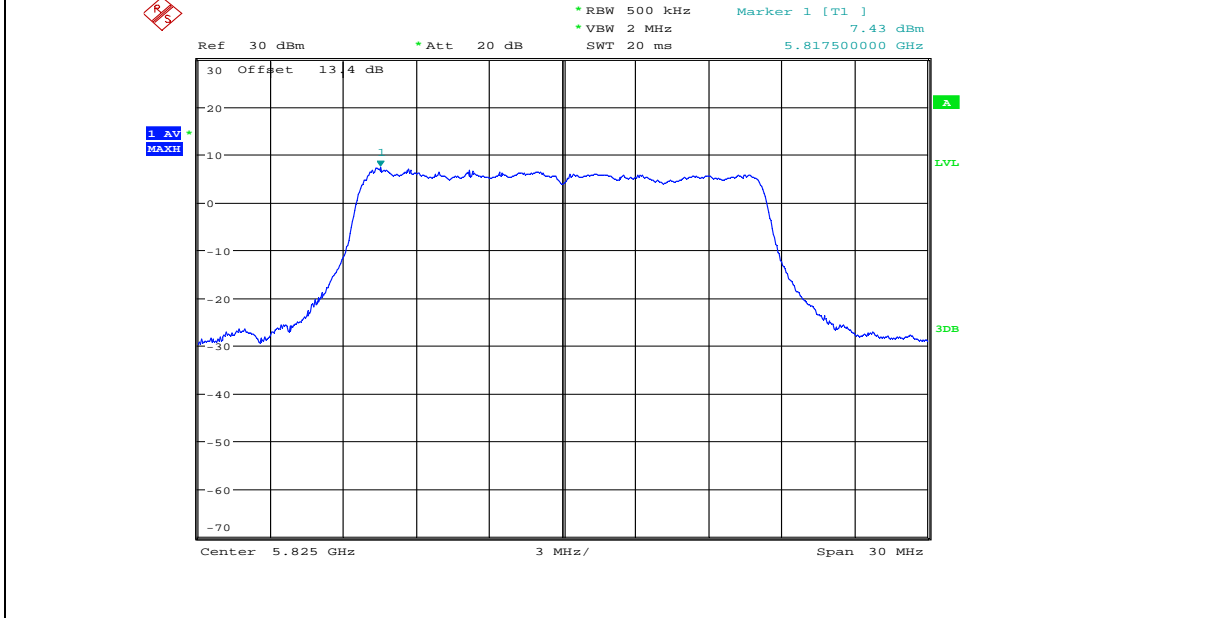



## 7. Frequency Stability Measurement

### 7.1. Limit of Frequency Stability

Manufacturers of U-NII devices are responsible for ensuring frequency stability such that an emission is maintained within the band of operation under all conditions of normal operation as specified in the user's manual.

### 7.2. Measuring Instruments

The measuring equipment is listed in the section 4 of this test report.

### 7.3. Test Procedures

- (1) To ensure emission at the band edge is maintained within the authorized band, those values shall be measured by radiation emissions at upper and lower frequency points, and finally compensated by frequency deviation as procedures below.
- (2) The EUT was operated at the maximum output power, and connected to the spectrum analyzer, which is set to maximum hold function and peak detector. The peak value of the power envelope was measured and noted. The upper and lower frequency points were respectively measured relatively 10dB lower than the measured peak value.
- (3) The frequency deviation was calculated by adding the upper frequency point and the lower frequency point divided by two. Those detailed values of frequency deviation are provided in table below.

### 7.4. Test Setup

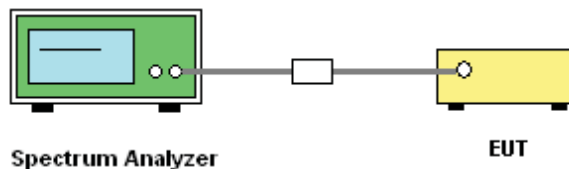

### 7.5. Test Result

Voltage vs. Frequency Stability								
TestMode	Antenna	Channel	Voltage [Vdc]	Temperature (°C)	Deviation (MHz)	Deviation (ppm)	Limit (ppm)	Verdict
11N20MIMO	ANT1	5180	NV	NT	0	0	20	PASS
11N20MIMO	ANT1	5180	LV	NT	0	0	20	PASS
11N20MIMO	ANT1	5180	HV	NT	-0.02	-3.861004	20	PASS
11N20MIMO	ANT2	5180	HV	NT	-0.02	-3.861004	20	PASS
11N20MIMO	ANT2	5180	NV	NT	-0.02	-3.861004	20	PASS
11N20MIMO	ANT2	5180	LV	NT	0	0	20	PASS
11N20MIMO	ANT3	5180	HV	NT	-0.02	-3.861004	20	PASS
11N20MIMO	ANT3	5180	NV	NT	-0.02	-3.861004	20	PASS
11N20MIMO	ANT3	5180	LV	NT	0	0	20	PASS
11N20MIMO	ANT1	5200	NV	NT	0	0	20	PASS
11N20MIMO	ANT1	5200	LV	NT	-0.02	-3.846154	20	PASS
11N20MIMO	ANT1	5200	HV	NT	0	0	20	PASS
11N20MIMO	ANT2	5200	HV	NT	-0.02	-3.846154	20	PASS
11N20MIMO	ANT2	5200	NV	NT	-0.02	-3.846154	20	PASS
11N20MIMO	ANT2	5200	LV	NT	0	0	20	PASS

11N20MIMO	ANT3	5200	HV	NT	0	0	20	PASS
11N20MIMO	ANT3	5200	LV	NT	0	0	20	PASS
11N20MIMO	ANT3	5200	NV	NT	-0.02	-3.846154	20	PASS
11N20MIMO	ANT1	5240	NV	NT	0	0	20	PASS
11N20MIMO	ANT1	5240	LV	NT	0	0	20	PASS
11N20MIMO	ANT1	5240	HV	NT	0	0	20	PASS
11N20MIMO	ANT2	5240	NV	NT	-0.02	-3.816794	20	PASS
11N20MIMO	ANT2	5240	LV	NT	0	0	20	PASS
11N20MIMO	ANT2	5240	HV	NT	-0.02	-3.816794	20	PASS
11N20MIMO	ANT3	5240	NV	NT	0	0	20	PASS
11N20MIMO	ANT3	5240	LV	NT	0	0	20	PASS
11N20MIMO	ANT3	5240	HV	NT	0	0	20	PASS
11N20MIMO	ANT1	5745	NV	NT	-0.04	-6.962576	20	PASS
11N20MIMO	ANT1	5745	LV	NT	-0.02	-3.481288	20	PASS
11N20MIMO	ANT1	5745	HV	NT	-0.04	-6.962576	20	PASS
11N20MIMO	ANT2	5745	NV	NT	-0.02	-3.481288	20	PASS
11N20MIMO	ANT2	5745	LV	NT	0	0	20	PASS
11N20MIMO	ANT2	5745	HV	NT	0	0	20	PASS
11N20MIMO	ANT3	5745	NV	NT	-0.04	-6.962576	20	PASS
11N20MIMO	ANT3	5745	HV	NT	-0.02	-3.481288	20	PASS
11N20MIMO	ANT3	5745	LV	NT	-0.04	-6.962576	20	PASS
11N20MIMO	ANT1	5785	NV	NT	0	0	20	PASS
11N20MIMO	ANT1	5785	LV	NT	-0.02	-3.457217	20	PASS
11N20MIMO	ANT1	5785	HV	NT	0	0	20	PASS
11N20MIMO	ANT2	5785	NV	NT	-0.02	-3.457217	20	PASS
11N20MIMO	ANT2	5785	LV	NT	-0.02	-3.457217	20	PASS
11N20MIMO	ANT2	5785	HV	NT	-0.02	-3.457217	20	PASS
11N20MIMO	ANT3	5785	NV	NT	0	0	20	PASS
11N20MIMO	ANT3	5785	LV	NT	-0.02	-3.457217	20	PASS
11N20MIMO	ANT3	5785	HV	NT	0	0	20	PASS
11N20MIMO	ANT1	5825	NV	NT	-0.02	-3.433476	20	PASS
11N20MIMO	ANT1	5825	LV	NT	-0.02	-3.433476	20	PASS
11N20MIMO	ANT1	5825	HV	NT	-0.02	-3.433476	20	PASS
11N20MIMO	ANT2	5825	NV	NT	-0.02	-3.433476	20	PASS
11N20MIMO	ANT2	5825	LV	NT	0	0	20	PASS
11N20MIMO	ANT2	5825	HV	NT	0	0	20	PASS
11N20MIMO	ANT3	5825	NV	NT	0	0	20	PASS
11N20MIMO	ANT3	5825	HV	NT	-0.02	-3.433476	20	PASS
11N20MIMO	ANT3	5825	LV	NT	-0.02	-3.433476	20	PASS
11N40MIMO	ANT1	5190	NV	NT	-0.04	-7.707129	20	PASS
11N40MIMO	ANT1	5190	LV	NT	-0.04	-7.707129	20	PASS
11N40MIMO	ANT1	5190	HV	NT	0	0	20	PASS
11N40MIMO	ANT2	5190	NV	NT	-0.04	-7.707129	20	PASS
11N40MIMO	ANT2	5190	LV	NT	-0.04	-7.707129	20	PASS
11N40MIMO	ANT2	5190	HV	NT	-0.04	-7.707129	20	PASS
11N40MIMO	ANT3	5190	NV	NT	0	0	20	PASS
11N40MIMO	ANT3	5190	LV	NT	-0.04	-7.707129	20	PASS
11N40MIMO	ANT3	5190	HV	NT	-0.04	-7.707129	20	PASS
11N40MIMO	ANT1	5230	HV	NT	-0.04	-7.648184	20	PASS
11N40MIMO	ANT1	5230	NV	NT	0	0	20	PASS
11N40MIMO	ANT1	5230	LV	NT	0	0	20	PASS

11N40MIMO	ANT2	5230	NV	NT	-0.04	-7.648184	20	PASS
11N40MIMO	ANT2	5230	LV	NT	0	0	20	PASS
11N40MIMO	ANT2	5230	HV	NT	-0.04	-7.648184	20	PASS
11N40MIMO	ANT3	5230	LV	NT	0	0	20	PASS
11N40MIMO	ANT3	5230	HV	NT	0	0	20	PASS
11N40MIMO	ANT3	5230	NV	NT	-0.04	-7.648184	20	PASS
11N40MIMO	ANT1	5755	NV	NT	-0.04	-6.950478	20	PASS
11N40MIMO	ANT1	5755	LV	NT	-0.04	-6.950478	20	PASS
11N40MIMO	ANT1	5755	HV	NT	0	0	20	PASS
11N40MIMO	ANT2	5755	HV	NT	-0.04	-6.950478	20	PASS
11N40MIMO	ANT2	5755	NV	NT	-0.04	-6.950478	20	PASS
11N40MIMO	ANT2	5755	LV	NT	0	0	20	PASS
11N40MIMO	ANT3	5755	LV	NT	0	0	20	PASS
11N40MIMO	ANT3	5755	HV	NT	-0.04	-6.950478	20	PASS
11N40MIMO	ANT3	5755	NV	NT	-0.04	-6.950478	20	PASS
11N40MIMO	ANT1	5795	NV	NT	0	0	20	PASS
11N40MIMO	ANT1	5795	LV	NT	-0.04	-6.902502	20	PASS
11N40MIMO	ANT1	5795	HV	NT	0	0	20	PASS
11N40MIMO	ANT2	5795	HV	NT	0	0	20	PASS
11N40MIMO	ANT2	5795	NV	NT	-0.04	-6.902502	20	PASS
11N40MIMO	ANT2	5795	LV	NT	-0.04	-6.902502	20	PASS
11N40MIMO	ANT3	5795	HV	NT	0	0	20	PASS
11N40MIMO	ANT3	5795	NV	NT	0	0	20	PASS
11N40MIMO	ANT3	5795	LV	NT	-0.04	-6.902502	20	PASS
11AC20MIMO	ANT1	5180	NV	NT	0	0	20	PASS
11AC20MIMO	ANT1	5180	LV	NT	0	0	20	PASS
11AC20MIMO	ANT1	5180	HV	NT	0	0	20	PASS
11AC20MIMO	ANT2	5180	LV	NT	0	0	20	PASS
11AC20MIMO	ANT2	5180	HV	NT	0	0	20	PASS
11AC20MIMO	ANT2	5180	NV	NT	-0.02	-3.861004	20	PASS
11AC20MIMO	ANT3	5180	LV	NT	-0.02	-3.861004	20	PASS
11AC20MIMO	ANT3	5180	NV	NT	-0.02	-3.861004	20	PASS
11AC20MIMO	ANT3	5180	HV	NT	0	0	20	PASS
11AC20MIMO	ANT1	5200	NV	NT	0.02	3.846154	20	PASS
11AC20MIMO	ANT1	5200	LV	NT	-0.02	-3.846154	20	PASS
11AC20MIMO	ANT1	5200	HV	NT	0.02	3.846154	20	PASS
11AC20MIMO	ANT2	5200	NV	NT	-0.02	-3.846154	20	PASS
11AC20MIMO	ANT2	5200	LV	NT	0	0	20	PASS
11AC20MIMO	ANT2	5200	HV	NT	-0.02	-3.846154	20	PASS
11AC20MIMO	ANT3	5200	NV	NT	0	0	20	PASS
11AC20MIMO	ANT3	5200	LV	NT	0	0	20	PASS
11AC20MIMO	ANT3	5200	HV	NT	0	0	20	PASS
11AC20MIMO	ANT1	5240	NV	NT	-0.02	-3.816794	20	PASS
11AC20MIMO	ANT1	5240	LV	NT	-0.02	-3.816794	20	PASS
11AC20MIMO	ANT1	5240	HV	NT	0	0	20	PASS
11AC20MIMO	ANT2	5240	NV	NT	-0.02	-3.816794	20	PASS
11AC20MIMO	ANT2	5240	LV	NT	0	0	20	PASS
11AC20MIMO	ANT2	5240	HV	NT	0	0	20	PASS
11AC20MIMO	ANT3	5240	NV	NT	-0.04	-7.633588	20	PASS
11AC20MIMO	ANT3	5240	LV	NT	-0.02	-3.816794	20	PASS
11AC20MIMO	ANT3	5240	HV	NT	-0.02	-3.816794	20	PASS

11AC20MIMO	ANT1	5745	LV	NT	0	0	20	PASS
11AC20MIMO	ANT1	5745	HV	NT	0	0	20	PASS
11AC20MIMO	ANT1	5745	NV	NT	0	0	20	PASS
11AC20MIMO	ANT2	5745	NV	NT	0	0	20	PASS
11AC20MIMO	ANT2	5745	LV	NT	0	0	20	PASS
11AC20MIMO	ANT2	5745	HV	NT	0	0	20	PASS
11AC20MIMO	ANT3	5745	NV	NT	0	0	20	PASS
11AC20MIMO	ANT3	5745	LV	NT	-0.02	-3.481288	20	PASS
11AC20MIMO	ANT3	5745	HV	NT	-0.02	-3.481288	20	PASS
11AC20MIMO	ANT1	5785	HV	NT	0	0	20	PASS
11AC20MIMO	ANT1	5785	NV	NT	0	0	20	PASS
11AC20MIMO	ANT1	5785	LV	NT	0	0	20	PASS
11AC20MIMO	ANT2	5785	HV	NT	-0.02	-3.457217	20	PASS
11AC20MIMO	ANT2	5785	NV	NT	0	0	20	PASS
11AC20MIMO	ANT2	5785	LV	NT	0	0	20	PASS
11AC20MIMO	ANT3	5785	NV	NT	0	0	20	PASS
11AC20MIMO	ANT3	5785	LV	NT	0	0	20	PASS
11AC20MIMO	ANT3	5785	HV	NT	0	0	20	PASS
11AC20MIMO	ANT1	5825	NV	NT	-0.02	-3.433476	20	PASS
11AC20MIMO	ANT1	5825	LV	NT	-0.02	-3.433476	20	PASS
11AC20MIMO	ANT1	5825	HV	NT	-0.02	-3.433476	20	PASS
11AC20MIMO	ANT2	5825	LV	NT	0	0	20	PASS
11AC20MIMO	ANT2	5825	HV	NT	0	0	20	PASS
11AC20MIMO	ANT2	5825	NV	NT	0	0	20	PASS
11AC20MIMO	ANT3	5825	LV	NT	0	0	20	PASS
11AC20MIMO	ANT3	5825	HV	NT	0	0	20	PASS
11AC20MIMO	ANT3	5825	NV	NT	0	0	20	PASS
11AC40MIMO	ANT1	5190	NV	NT	-0.04	-7.707129	20	PASS
11AC40MIMO	ANT1	5190	LV	NT	-0.04	-7.707129	20	PASS
11AC40MIMO	ANT1	5190	HV	NT	-0.04	-7.707129	20	PASS
11AC40MIMO	ANT2	5190	HV	NT	-0.04	-7.707129	20	PASS
11AC40MIMO	ANT2	5190	NV	NT	-0.04	-7.707129	20	PASS
11AC40MIMO	ANT2	5190	LV	NT	-0.04	-7.707129	20	PASS
11AC40MIMO	ANT3	5190	HV	NT	0	0	20	PASS
11AC40MIMO	ANT3	5190	NV	NT	-0.04	-7.707129	20	PASS
11AC40MIMO	ANT3	5190	LV	NT	-0.04	-7.707129	20	PASS
11AC40MIMO	ANT1	5230	NV	NT	-0.02	-3.824092	20	PASS
11AC40MIMO	ANT1	5230	LV	NT	-0.02	-3.824092	20	PASS
11AC40MIMO	ANT1	5230	HV	NT	-0.02	-3.824092	20	PASS
11AC40MIMO	ANT2	5230	NV	NT	0	0	20	PASS
11AC40MIMO	ANT2	5230	LV	NT	0	0	20	PASS
11AC40MIMO	ANT2	5230	HV	NT	0	0	20	PASS
11AC40MIMO	ANT3	5230	LV	NT	-0.02	-3.824092	20	PASS
11AC40MIMO	ANT3	5230	HV	NT	-0.02	-3.824092	20	PASS
11AC40MIMO	ANT3	5230	NV	NT	-0.02	-3.824092	20	PASS
11AC40MIMO	ANT1	5755	NV	NT	0	0	20	PASS
11AC40MIMO	ANT1	5755	LV	NT	0	0	20	PASS
11AC40MIMO	ANT1	5755	HV	NT	0	0	20	PASS
11AC40MIMO	ANT2	5755	NV	NT	-0.04	-6.950478	20	PASS
11AC40MIMO	ANT2	5755	LV	NT	-0.04	-6.950478	20	PASS
11AC40MIMO	ANT2	5755	HV	NT	-0.04	-6.950478	20	PASS

11AC40MIMO	ANT3	5755	NV	NT	-0.04	-6.950478	20	PASS
11AC40MIMO	ANT3	5755	LV	NT	-0.04	-6.950478	20	PASS
11AC40MIMO	ANT3	5755	HV	NT	-0.04	-6.950478	20	PASS
11AC40MIMO	ANT1	5795	NV	NT	-0.02	-3.451251	20	PASS
11AC40MIMO	ANT1	5795	LV	NT	-0.02	-3.451251	20	PASS
11AC40MIMO	ANT1	5795	HV	NT	-0.02	-3.451251	20	PASS
11AC40MIMO	ANT2	5795	LV	NT	-0.04	-6.902502	20	PASS
11AC40MIMO	ANT2	5795	HV	NT	-0.04	-6.902502	20	PASS
11AC40MIMO	ANT2	5795	NV	NT	-0.04	-6.902502	20	PASS
11AC40MIMO	ANT3	5795	LV	NT	-0.04	-6.902502	20	PASS
11AC40MIMO	ANT3	5795	HV	NT	0	0	20	PASS
11AC40MIMO	ANT3	5795	NV	NT	-0.04	-6.902502	20	PASS
11AC80MIMO	ANT1	5210	NV	NT	0	0	20	PASS
11AC80MIMO	ANT1	5210	LV	NT	0	0	20	PASS
11AC80MIMO	ANT1	5210	HV	NT	0	0	20	PASS
11AC80MIMO	ANT2	5210	NV	NT	0	0	20	PASS
11AC80MIMO	ANT2	5210	LV	NT	0	0	20	PASS
11AC80MIMO	ANT2	5210	HV	NT	0	0	20	PASS
11AC80MIMO	ANT3	5210	NV	NT	0	0	20	PASS
11AC80MIMO	ANT3	5210	LV	NT	0	0	20	PASS
11AC80MIMO	ANT3	5210	HV	NT	0	0	20	PASS
11AC80MIMO	ANT1	5775	LV	NT	0	0	20	PASS
11AC80MIMO	ANT1	5775	HV	NT	0	0	20	PASS
11AC80MIMO	ANT1	5775	NV	NT	0	0	20	PASS
11AC80MIMO	ANT2	5775	NV	NT	0	0	20	PASS
11AC80MIMO	ANT2	5775	LV	NT	0	0	20	PASS
11AC80MIMO	ANT2	5775	HV	NT	0	0	20	PASS
11AC80MIMO	ANT3	5775	HV	NT	0	0	20	PASS
11AC80MIMO	ANT3	5775	LV	NT	0	0	20	PASS
11AC80MIMO	ANT3	5775	NV	NT	-0.08	-13.852814	20	PASS
11ASISO	ANT1	5180	NV	NT	-0.02	-3.861004	20	PASS
11ASISO	ANT1	5180	LV	NT	-0.02	-3.861004	20	PASS
11ASISO	ANT1	5180	HV	NT	-0.02	-3.861004	20	PASS
11ASISO	ANT1	5200	NV	NT	-0.02	-3.846154	20	PASS
11ASISO	ANT1	5200	LV	NT	-0.02	-3.846154	20	PASS
11ASISO	ANT1	5200	HV	NT	-0.02	-3.846154	20	PASS
11ASISO	ANT1	5240	HV	NT	-0.02	-3.816794	20	PASS
11ASISO	ANT1	5240	LV	NT	-0.02	-3.816794	20	PASS
11ASISO	ANT1	5240	NV	NT	-0.02	-3.816794	20	PASS
11ASISO	ANT1	5745	HV	NT	0	0	20	PASS
11ASISO	ANT1	5745	NV	NT	0	0	20	PASS
11ASISO	ANT1	5745	LV	NT	0	0	20	PASS
11ASISO	ANT1	5785	NV	NT	-0.02	-3.457217	20	PASS
11ASISO	ANT1	5785	HV	NT	-0.02	-3.457217	20	PASS
11ASISO	ANT1	5785	LV	NT	-0.02	-3.457217	20	PASS
11ASISO	ANT1	5825	NV	NT	-0.02	-3.433476	20	PASS
11ASISO	ANT1	5825	HV	NT	-0.02	-3.433476	20	PASS
11ASISO	ANT1	5825	LV	NT	-0.02	-3.433476	20	PASS

Temperature vs. Frequency Stability								
TestMode	Antenna	Channel	Voltage [Vdc]	Temperature (°C)	Deviation (Hz)	Deviation (ppm)	Limit (ppm)	Verdict
11A	ANT1	5180	NV	-30	-0.02	-3.861004	20	PASS
11A	ANT1	5180	NV	-20	-0.02	-3.861004	20	PASS
11A	ANT1	5180	NV	-10	-0.02	-3.861004	20	PASS
11A	ANT1	5180	NV	0	-0.02	-3.861004	20	PASS
11A	ANT1	5180	NV	10	-0.02	-3.861004	20	PASS
11A	ANT1	5180	NV	20	-0.02	-3.861004	20	PASS
11A	ANT1	5180	NV	30	-0.02	-3.861004	20	PASS
11A	ANT1	5180	NV	40	-0.02	-3.861004	20	PASS
11A	ANT1	5180	NV	50	-0.02	-3.861004	20	PASS
11N20MIMO	ANT1	5180	NV	-30	-0.02	-3.861004	20	PASS
11N20MIMO	ANT1	5180	NV	-20	-0.02	-3.861004	20	PASS
11N20MIMO	ANT1	5180	NV	-10	-0.02	-3.861004	20	PASS
11N20MIMO	ANT1	5180	NV	0	-0.02	-3.861004	20	PASS
11N20MIMO	ANT1	5180	NV	10	0	0	20	PASS
11N20MIMO	ANT1	5180	NV	20	0	0	20	PASS
11N20MIMO	ANT1	5180	NV	30	0	0	20	PASS
11N20MIMO	ANT1	5180	NV	40	0.02	3.861004	20	PASS
11N20MIMO	ANT1	5180	NV	50	0	0	20	PASS
11N20MIMO	ANT2	5180	NV	-30	0	0	20	PASS
11N20MIMO	ANT2	5180	NV	-20	0	0	20	PASS
11N20MIMO	ANT2	5180	NV	-10	0	0	20	PASS
11N20MIMO	ANT2	5180	NV	0	0	0	20	PASS
11N20MIMO	ANT2	5180	NV	10	-0.02	-3.861004	20	PASS
11N20MIMO	ANT2	5180	NV	20	0	0	20	PASS
11N20MIMO	ANT2	5180	NV	30	0	0	20	PASS
11N20MIMO	ANT2	5180	NV	40	-0.02	-3.861004	20	PASS
11N20MIMO	ANT2	5180	NV	50	0	0	20	PASS
11N20MIMO	ANT3	5180	NV	-30	0	0	20	PASS
11N20MIMO	ANT3	5180	NV	-20	0	0	20	PASS
11N20MIMO	ANT3	5180	NV	-10	0	0	20	PASS
11N20MIMO	ANT3	5180	NV	0	0	0	20	PASS
11N20MIMO	ANT3	5180	NV	10	0	0	20	PASS
11N20MIMO	ANT3	5180	NV	20	0	0	20	PASS
11N20MIMO	ANT3	5180	NV	30	0	0	20	PASS
11N20MIMO	ANT3	5180	NV	40	0	0	20	PASS
11N20MIMO	ANT3	5180	NV	50	0	0	20	PASS
11N20MIMO	ANT1	5200	NV	-30	0	0	20	PASS
11N20MIMO	ANT1	5200	NV	-20	0	0	20	PASS
11N20MIMO	ANT1	5200	NV	-10	0	0	20	PASS
11N20MIMO	ANT1	5200	NV	0	-0.02	-3.846154	20	PASS
11N20MIMO	ANT1	5200	NV	10	0	0	20	PASS
11N20MIMO	ANT1	5200	NV	20	-0.02	-3.846154	20	PASS
11N20MIMO	ANT1	5200	NV	30	0	0	20	PASS
11N20MIMO	ANT1	5200	NV	40	-0.02	-3.846154	20	PASS
11N20MIMO	ANT1	5200	NV	50	-0.02	-3.846154	20	PASS
11N20MIMO	ANT2	5200	NV	-30	0	0	20	PASS
11N20MIMO	ANT2	5200	NV	-20	0	0	20	PASS
11N20MIMO	ANT2	5200	NV	-10	0	0	20	PASS
11N20MIMO	ANT2	5200	NV	0	0	0	20	PASS

11N20MIMO	ANT2	5200	NV	10	0	0	20	PASS
11N20MIMO	ANT2	5200	NV	20	0	0	20	PASS
11N20MIMO	ANT2	5200	NV	30	-0.02	-3.846154	20	PASS
11N20MIMO	ANT2	5200	NV	40	0	0	20	PASS
11N20MIMO	ANT2	5200	NV	50	0	0	20	PASS
11N20MIMO	ANT3	5200	NV	-30	-0.02	-3.846154	20	PASS
11N20MIMO	ANT3	5200	NV	-20	-0.02	-3.846154	20	PASS
11N20MIMO	ANT3	5200	NV	-10	-0.02	-3.846154	20	PASS
11N20MIMO	ANT3	5200	NV	0	-0.02	-3.846154	20	PASS
11N20MIMO	ANT3	5200	NV	10	0	0	20	PASS
11N20MIMO	ANT3	5200	NV	20	-0.02	-3.846154	20	PASS
11N20MIMO	ANT3	5200	NV	30	-0.02	-3.846154	20	PASS
11N20MIMO	ANT3	5200	NV	40	-0.02	-3.846154	20	PASS
11N20MIMO	ANT3	5200	NV	50	-0.02	-3.846154	20	PASS
11N20MIMO	ANT1	5240	NV	-30	0	0	20	PASS
11N20MIMO	ANT1	5240	NV	-20	-0.02	-3.816794	20	PASS
11N20MIMO	ANT1	5240	NV	-10	0	0	20	PASS
11N20MIMO	ANT1	5240	NV	0	-0.02	-3.816794	20	PASS
11N20MIMO	ANT1	5240	NV	10	-0.02	-3.816794	20	PASS
11N20MIMO	ANT1	5240	NV	20	0	0	20	PASS
11N20MIMO	ANT1	5240	NV	30	-0.02	-3.816794	20	PASS
11N20MIMO	ANT1	5240	NV	40	0	0	20	PASS
11N20MIMO	ANT1	5240	NV	50	-0.02	-3.816794	20	PASS
11N20MIMO	ANT2	5240	NV	-30	0	0	20	PASS
11N20MIMO	ANT2	5240	NV	-20	0	0	20	PASS
11N20MIMO	ANT2	5240	NV	-10	0	0	20	PASS
11N20MIMO	ANT2	5240	NV	0	0	0	20	PASS
11N20MIMO	ANT2	5240	NV	10	-0.02	-3.816794	20	PASS
11N20MIMO	ANT2	5240	NV	20	0	0	20	PASS
11N20MIMO	ANT2	5240	NV	30	-0.02	-3.816794	20	PASS
11N20MIMO	ANT2	5240	NV	40	0	0	20	PASS
11N20MIMO	ANT2	5240	NV	50	0	0	20	PASS
11N20MIMO	ANT3	5240	NV	-30	0	0	20	PASS
11N20MIMO	ANT3	5240	NV	-20	0	0	20	PASS
11N20MIMO	ANT3	5240	NV	-10	0	0	20	PASS
11N20MIMO	ANT3	5240	NV	0	0	0	20	PASS
11N20MIMO	ANT3	5240	NV	10	0	0	20	PASS
11N20MIMO	ANT3	5240	NV	20	0	0	20	PASS
11N20MIMO	ANT3	5240	NV	30	0	0	20	PASS
11N20MIMO	ANT3	5240	NV	40	0	0	20	PASS
11N20MIMO	ANT3	5240	NV	50	0	0	20	PASS
11N20MIMO	ANT1	5745	NV	-30	-0.02	-3.481288	20	PASS
11N20MIMO	ANT1	5745	NV	-20	-0.04	-6.962576	20	PASS
11N20MIMO	ANT1	5745	NV	-10	-0.02	-3.481288	20	PASS
11N20MIMO	ANT1	5745	NV	0	-0.02	-3.481288	20	PASS
11N20MIMO	ANT1	5745	NV	10	-0.02	-3.481288	20	PASS
11N20MIMO	ANT1	5745	NV	20	-0.04	-6.962576	20	PASS
11N20MIMO	ANT1	5745	NV	30	-0.04	-6.962576	20	PASS
11N20MIMO	ANT1	5745	NV	40	-0.04	-6.962576	20	PASS
11N20MIMO	ANT1	5745	NV	50	-0.02	-3.481288	20	PASS
11N20MIMO	ANT2	5745	NV	-30	0	0	20	PASS

11N20MIMO	ANT2	5745	NV	-20	-0.02	-3.481288	20	PASS
11N20MIMO	ANT2	5745	NV	-10	-0.02	-3.481288	20	PASS
11N20MIMO	ANT2	5745	NV	0	-0.02	-3.481288	20	PASS
11N20MIMO	ANT2	5745	NV	10	0	0	20	PASS
11N20MIMO	ANT2	5745	NV	20	0	0	20	PASS
11N20MIMO	ANT2	5745	NV	30	0	0	20	PASS
11N20MIMO	ANT2	5745	NV	40	0	0	20	PASS
11N20MIMO	ANT2	5745	NV	50	0	0	20	PASS
11N20MIMO	ANT3	5745	NV	-30	0	0	20	PASS
11N20MIMO	ANT3	5745	NV	-20	-0.04	-6.962576	20	PASS
11N20MIMO	ANT3	5745	NV	-10	-0.02	-3.481288	20	PASS
11N20MIMO	ANT3	5745	NV	0	-0.02	-3.481288	20	PASS
11N20MIMO	ANT3	5745	NV	10	-0.04	-6.962576	20	PASS
11N20MIMO	ANT3	5745	NV	20	-0.04	-6.962576	20	PASS
11N20MIMO	ANT3	5745	NV	30	-0.04	-6.962576	20	PASS
11N20MIMO	ANT3	5745	NV	40	-0.02	-3.481288	20	PASS
11N20MIMO	ANT3	5745	NV	50	-0.04	-6.962576	20	PASS
11N20MIMO	ANT1	5785	NV	-30	0	0	20	PASS
11N20MIMO	ANT1	5785	NV	-20	0	0	20	PASS
11N20MIMO	ANT1	5785	NV	-10	-0.02	-3.457217	20	PASS
11N20MIMO	ANT1	5785	NV	0	-0.02	-3.457217	20	PASS
11N20MIMO	ANT1	5785	NV	10	-0.02	-3.457217	20	PASS
11N20MIMO	ANT1	5785	NV	20	-0.02	-3.457217	20	PASS
11N20MIMO	ANT1	5785	NV	30	0	0	20	PASS
11N20MIMO	ANT1	5785	NV	40	0	0	20	PASS
11N20MIMO	ANT1	5785	NV	50	0	0	20	PASS
11N20MIMO	ANT2	5785	NV	-30	-0.02	-3.457217	20	PASS
11N20MIMO	ANT2	5785	NV	-20	0	0	20	PASS
11N20MIMO	ANT2	5785	NV	-10	0	0	20	PASS
11N20MIMO	ANT2	5785	NV	0	0	0	20	PASS
11N20MIMO	ANT2	5785	NV	10	0	0	20	PASS
11N20MIMO	ANT2	5785	NV	20	0	0	20	PASS
11N20MIMO	ANT2	5785	NV	30	0	0	20	PASS
11N20MIMO	ANT2	5785	NV	40	0	0	20	PASS
11N20MIMO	ANT2	5785	NV	50	0	0	20	PASS
11N20MIMO	ANT3	5785	NV	-30	0	0	20	PASS
11N20MIMO	ANT3	5785	NV	-20	0	0	20	PASS
11N20MIMO	ANT3	5785	NV	-10	0	0	20	PASS
11N20MIMO	ANT3	5785	NV	0	0	0	20	PASS
11N20MIMO	ANT3	5785	NV	10	0	0	20	PASS
11N20MIMO	ANT3	5785	NV	20	-0.02	-3.457217	20	PASS
11N20MIMO	ANT3	5785	NV	30	0	0	20	PASS
11N20MIMO	ANT3	5785	NV	40	0	0	20	PASS
11N20MIMO	ANT3	5785	NV	50	-0.02	-3.457217	20	PASS
11N20MIMO	ANT1	5825	NV	-30	-0.02	-3.433476	20	PASS
11N20MIMO	ANT1	5825	NV	-20	-0.02	-3.433476	20	PASS
11N20MIMO	ANT1	5825	NV	-10	-0.02	-3.433476	20	PASS
11N20MIMO	ANT1	5825	NV	0	-0.02	-3.433476	20	PASS
11N20MIMO	ANT1	5825	NV	10	-0.02	-3.433476	20	PASS
11N20MIMO	ANT1	5825	NV	20	-0.02	-3.433476	20	PASS
11N20MIMO	ANT1	5825	NV	30	-0.02	-3.433476	20	PASS



11N20MIMO	ANT1	5825	NV	40	-0.02	-3.433476	20	PASS
11N20MIMO	ANT1	5825	NV	50	-0.02	-3.433476	20	PASS
11N20MIMO	ANT2	5825	NV	-30	0	0	20	PASS
11N20MIMO	ANT2	5825	NV	-20	-0.02	-3.433476	20	PASS
11N20MIMO	ANT2	5825	NV	-10	0	0	20	PASS
11N20MIMO	ANT2	5825	NV	0	-0.02	-3.433476	20	PASS
11N20MIMO	ANT2	5825	NV	10	-0.02	-3.433476	20	PASS
11N20MIMO	ANT2	5825	NV	20	-0.02	-3.433476	20	PASS
11N20MIMO	ANT2	5825	NV	30	0	0	20	PASS
11N20MIMO	ANT2	5825	NV	40	0	0	20	PASS
11N20MIMO	ANT2	5825	NV	50	0	0	20	PASS
11N20MIMO	ANT3	5825	NV	-30	0	0	20	PASS
11N20MIMO	ANT3	5825	NV	-20	0	0	20	PASS
11N20MIMO	ANT3	5825	NV	-10	0	0	20	PASS
11N20MIMO	ANT3	5825	NV	0	-0.02	-3.433476	20	PASS
11N20MIMO	ANT3	5825	NV	10	-0.02	-3.433476	20	PASS
11N20MIMO	ANT3	5825	NV	20	-0.02	-3.433476	20	PASS
11N20MIMO	ANT3	5825	NV	30	-0.02	-3.433476	20	PASS
11N20MIMO	ANT3	5825	NV	40	-0.02	-3.433476	20	PASS
11N20MIMO	ANT3	5825	NV	50	-0.02	-3.433476	20	PASS
11N40MIMO	ANT1	5190	NV	-30	-0.04	-7.707129	20	PASS
11N40MIMO	ANT1	5190	NV	-20	-0.04	-7.707129	20	PASS
11N40MIMO	ANT1	5190	NV	-10	0	0	20	PASS
11N40MIMO	ANT1	5190	NV	0	-0.04	-7.707129	20	PASS
11N40MIMO	ANT1	5190	NV	10	0	0	20	PASS
11N40MIMO	ANT1	5190	NV	20	0.04	7.707129	20	PASS
11N40MIMO	ANT1	5190	NV	30	0	0	20	PASS
11N40MIMO	ANT1	5190	NV	40	-0.04	-7.707129	20	PASS
11N40MIMO	ANT1	5190	NV	50	0	0	20	PASS
11N40MIMO	ANT2	5190	NV	-30	0	0	20	PASS
11N40MIMO	ANT2	5190	NV	-20	-0.04	-7.707129	20	PASS
11N40MIMO	ANT2	5190	NV	-10	-0.04	-7.707129	20	PASS
11N40MIMO	ANT2	5190	NV	0	0	0	20	PASS
11N40MIMO	ANT2	5190	NV	10	-0.04	-7.707129	20	PASS
11N40MIMO	ANT2	5190	NV	20	-0.04	-7.707129	20	PASS
11N40MIMO	ANT2	5190	NV	30	-0.04	-7.707129	20	PASS
11N40MIMO	ANT2	5190	NV	40	-0.04	-7.707129	20	PASS
11N40MIMO	ANT2	5190	NV	50	0	0	20	PASS
11N40MIMO	ANT3	5190	NV	-30	0	0	20	PASS
11N40MIMO	ANT3	5190	NV	-20	0	0	20	PASS
11N40MIMO	ANT3	5190	NV	-10	0	0	20	PASS
11N40MIMO	ANT3	5190	NV	0	0	0	20	PASS
11N40MIMO	ANT3	5190	NV	10	0	0	20	PASS
11N40MIMO	ANT3	5190	NV	20	0	0	20	PASS
11N40MIMO	ANT3	5190	NV	30	0	0	20	PASS
11N40MIMO	ANT3	5190	NV	40	-0.04	-7.707129	20	PASS
11N40MIMO	ANT3	5190	NV	50	0	0	20	PASS
11N40MIMO	ANT1	5230	NV	-30	0.02	3.824092	20	PASS
11N40MIMO	ANT1	5230	NV	-20	0.02	3.824092	20	PASS
11N40MIMO	ANT1	5230	NV	-10	0.02	3.824092	20	PASS
11N40MIMO	ANT1	5230	NV	0	0.02	3.824092	20	PASS

11N40MIMO	ANT1	5230	NV	10	0.06	11.472275	20	PASS
11N40MIMO	ANT1	5230	NV	20	0.02	3.824092	20	PASS
11N40MIMO	ANT1	5230	NV	30	0.02	3.824092	20	PASS
11N40MIMO	ANT1	5230	NV	40	0.02	3.824092	20	PASS
11N40MIMO	ANT1	5230	NV	50	0.02	3.824092	20	PASS
11N40MIMO	ANT2	5230	NV	-30	-0.04	-7.648184	20	PASS
11N40MIMO	ANT2	5230	NV	-20	-0.04	-7.648184	20	PASS
11N40MIMO	ANT2	5230	NV	-10	-0.04	-7.648184	20	PASS
11N40MIMO	ANT2	5230	NV	0	-0.04	-7.648184	20	PASS
11N40MIMO	ANT2	5230	NV	10	-0.04	-7.648184	20	PASS
11N40MIMO	ANT2	5230	NV	20	-0.04	-7.648184	20	PASS
11N40MIMO	ANT2	5230	NV	30	-0.04	-7.648184	20	PASS
11N40MIMO	ANT2	5230	NV	40	-0.04	-7.648184	20	PASS
11N40MIMO	ANT2	5230	NV	50	-0.04	-7.648184	20	PASS
11N40MIMO	ANT3	5230	NV	-30	-0.02	-3.824092	20	PASS
11N40MIMO	ANT3	5230	NV	-20	-0.02	-3.824092	20	PASS
11N40MIMO	ANT3	5230	NV	-10	-0.02	-3.824092	20	PASS
11N40MIMO	ANT3	5230	NV	0	-0.02	-3.824092	20	PASS
11N40MIMO	ANT3	5230	NV	10	-0.02	-3.824092	20	PASS
11N40MIMO	ANT3	5230	NV	20	-0.02	-3.824092	20	PASS
11N40MIMO	ANT3	5230	NV	30	-0.02	-3.824092	20	PASS
11N40MIMO	ANT3	5230	NV	40	-0.02	-3.824092	20	PASS
11N40MIMO	ANT3	5230	NV	50	-0.02	-3.824092	20	PASS
11N40MIMO	ANT1	5755	NV	-30	-0.04	-6.950478	20	PASS
11N40MIMO	ANT1	5755	NV	-20	-0.04	-6.950478	20	PASS
11N40MIMO	ANT1	5755	NV	-10	-0.04	-6.950478	20	PASS
11N40MIMO	ANT1	5755	NV	0	-0.04	-6.950478	20	PASS
11N40MIMO	ANT1	5755	NV	10	-0.04	-6.950478	20	PASS
11N40MIMO	ANT1	5755	NV	20	-0.04	-6.950478	20	PASS
11N40MIMO	ANT1	5755	NV	30	-0.04	-6.950478	20	PASS
11N40MIMO	ANT1	5755	NV	40	-0.04	-6.950478	20	PASS
11N40MIMO	ANT1	5755	NV	50	-0.04	-6.950478	20	PASS
11N40MIMO	ANT2	5755	NV	-30	-0.04	-6.950478	20	PASS
11N40MIMO	ANT2	5755	NV	-20	-0.04	-6.950478	20	PASS
11N40MIMO	ANT2	5755	NV	-10	-0.04	-6.950478	20	PASS
11N40MIMO	ANT2	5755	NV	0	-0.04	-6.950478	20	PASS
11N40MIMO	ANT2	5755	NV	10	-0.04	-6.950478	20	PASS
11N40MIMO	ANT2	5755	NV	20	-0.04	-6.950478	20	PASS
11N40MIMO	ANT2	5755	NV	30	-0.04	-6.950478	20	PASS
11N40MIMO	ANT2	5755	NV	40	-0.04	-6.950478	20	PASS
11N40MIMO	ANT2	5755	NV	50	-0.04	-6.950478	20	PASS
11N40MIMO	ANT3	5755	NV	-30	-0.04	-6.950478	20	PASS
11N40MIMO	ANT3	5755	NV	-20	-0.04	-6.950478	20	PASS
11N40MIMO	ANT3	5755	NV	-10	-0.04	-6.950478	20	PASS
11N40MIMO	ANT3	5755	NV	0	-0.04	-6.950478	20	PASS
11N40MIMO	ANT3	5755	NV	10	-0.04	-6.950478	20	PASS
11N40MIMO	ANT3	5755	NV	20	-0.04	-6.950478	20	PASS
11N40MIMO	ANT3	5755	NV	30	-0.04	-6.950478	20	PASS
11N40MIMO	ANT3	5755	NV	40	-0.04	-6.950478	20	PASS
11N40MIMO	ANT3	5755	NV	50	-0.04	-6.950478	20	PASS
11N40MIMO	ANT1	5795	NV	-30	0	0	20	PASS

11N40MIMO	ANT1	5795	NV	-20	0	0	20	PASS
11N40MIMO	ANT1	5795	NV	-10	-0.04	-6.902502	20	PASS
11N40MIMO	ANT1	5795	NV	0	-0.04	-6.902502	20	PASS
11N40MIMO	ANT1	5795	NV	10	0	0	20	PASS
11N40MIMO	ANT1	5795	NV	20	0	0	20	PASS
11N40MIMO	ANT1	5795	NV	30	0	0	20	PASS
11N40MIMO	ANT1	5795	NV	40	-0.04	-6.902502	20	PASS
11N40MIMO	ANT1	5795	NV	50	0	0	20	PASS
11N40MIMO	ANT2	5795	NV	-30	-0.04	-6.902502	20	PASS
11N40MIMO	ANT2	5795	NV	-20	-0.04	-6.902502	20	PASS
11N40MIMO	ANT2	5795	NV	-10	-0.04	-6.902502	20	PASS
11N40MIMO	ANT2	5795	NV	0	-0.04	-6.902502	20	PASS
11N40MIMO	ANT2	5795	NV	10	-0.04	-6.902502	20	PASS
11N40MIMO	ANT2	5795	NV	20	-0.04	-6.902502	20	PASS
11N40MIMO	ANT2	5795	NV	30	-0.04	-6.902502	20	PASS
11N40MIMO	ANT2	5795	NV	40	-0.04	-6.902502	20	PASS
11N40MIMO	ANT2	5795	NV	50	-0.04	-6.902502	20	PASS
11N40MIMO	ANT3	5795	NV	-30	-0.04	-6.902502	20	PASS
11N40MIMO	ANT3	5795	NV	-20	0	0	20	PASS
11N40MIMO	ANT3	5795	NV	-10	-0.04	-6.902502	20	PASS
11N40MIMO	ANT3	5795	NV	0	0	0	20	PASS
11N40MIMO	ANT3	5795	NV	10	-0.04	-6.902502	20	PASS
11N40MIMO	ANT3	5795	NV	20	-0.04	-6.902502	20	PASS
11N40MIMO	ANT3	5795	NV	30	0	0	20	PASS
11N40MIMO	ANT3	5795	NV	40	0	0	20	PASS
11N40MIMO	ANT3	5795	NV	50	-0.04	-6.902502	20	PASS
11AC20MIMO	ANT1	5180	NV	-30	0	0	20	PASS
11AC20MIMO	ANT1	5180	NV	-20	-0.02	-3.861004	20	PASS
11AC20MIMO	ANT1	5180	NV	-10	0	0	20	PASS
11AC20MIMO	ANT1	5180	NV	0	0	0	20	PASS
11AC20MIMO	ANT1	5180	NV	10	0	0	20	PASS
11AC20MIMO	ANT1	5180	NV	20	0	0	20	PASS
11AC20MIMO	ANT1	5180	NV	30	0	0	20	PASS
11AC20MIMO	ANT1	5180	NV	40	0	0	20	PASS
11AC20MIMO	ANT1	5180	NV	50	0	0	20	PASS
11AC20MIMO	ANT2	5180	NV	-30	0	0	20	PASS
11AC20MIMO	ANT2	5180	NV	-20	-0.02	-3.861004	20	PASS
11AC20MIMO	ANT2	5180	NV	-10	0	0	20	PASS
11AC20MIMO	ANT2	5180	NV	0	0	0	20	PASS
11AC20MIMO	ANT2	5180	NV	10	0	0	20	PASS
11AC20MIMO	ANT2	5180	NV	20	0	0	20	PASS
11AC20MIMO	ANT2	5180	NV	30	-0.02	-3.861004	20	PASS
11AC20MIMO	ANT2	5180	NV	40	0	0	20	PASS
11AC20MIMO	ANT2	5180	NV	50	0	0	20	PASS
11AC20MIMO	ANT3	5180	NV	-30	0	0	20	PASS
11AC20MIMO	ANT3	5180	NV	-20	0	0	20	PASS
11AC20MIMO	ANT3	5180	NV	-10	0	0	20	PASS
11AC20MIMO	ANT3	5180	NV	0	-0.02	-3.861004	20	PASS
11AC20MIMO	ANT3	5180	NV	10	-0.02	-3.861004	20	PASS
11AC20MIMO	ANT3	5180	NV	20	-0.02	-3.861004	20	PASS
11AC20MIMO	ANT3	5180	NV	30	0	0	20	PASS

11AC20MIMO	ANT3	5180	NV	40	-0.02	-3.861004	20	PASS
11AC20MIMO	ANT3	5180	NV	50	0	0	20	PASS
11AC20MIMO	ANT1	5200	NV	-30	0	0	20	PASS
11AC20MIMO	ANT1	5200	NV	-20	0	0	20	PASS
11AC20MIMO	ANT1	5200	NV	-10	0	0	20	PASS
11AC20MIMO	ANT1	5200	NV	0	0	0	20	PASS
11AC20MIMO	ANT1	5200	NV	10	0	0	20	PASS
11AC20MIMO	ANT1	5200	NV	20	0	0	20	PASS
11AC20MIMO	ANT1	5200	NV	30	0	0	20	PASS
11AC20MIMO	ANT1	5200	NV	40	0	0	20	PASS
11AC20MIMO	ANT1	5200	NV	50	0.02	3.846154	20	PASS
11AC20MIMO	ANT2	5200	NV	-30	0.02	3.846154	20	PASS
11AC20MIMO	ANT2	5200	NV	-20	0	0	20	PASS
11AC20MIMO	ANT2	5200	NV	-10	0	0	20	PASS
11AC20MIMO	ANT2	5200	NV	0	0	0	20	PASS
11AC20MIMO	ANT2	5200	NV	10	-0.02	-3.846154	20	PASS
11AC20MIMO	ANT2	5200	NV	20	-0.02	-3.846154	20	PASS
11AC20MIMO	ANT2	5200	NV	30	0.02	3.846154	20	PASS
11AC20MIMO	ANT2	5200	NV	40	0	0	20	PASS
11AC20MIMO	ANT2	5200	NV	50	0	0	20	PASS
11AC20MIMO	ANT3	5200	NV	-30	-0.02	-3.846154	20	PASS
11AC20MIMO	ANT3	5200	NV	-20	0	0	20	PASS
11AC20MIMO	ANT3	5200	NV	-10	-0.02	-3.846154	20	PASS
11AC20MIMO	ANT3	5200	NV	0	-0.02	-3.846154	20	PASS
11AC20MIMO	ANT3	5200	NV	10	-0.02	-3.846154	20	PASS
11AC20MIMO	ANT3	5200	NV	20	0	0	20	PASS
11AC20MIMO	ANT3	5200	NV	30	0	0	20	PASS
11AC20MIMO	ANT3	5200	NV	40	0	0	20	PASS
11AC20MIMO	ANT3	5200	NV	50	0.02	3.846154	20	PASS
11AC20MIMO	ANT1	5240	NV	-30	-0.02	-3.816794	20	PASS
11AC20MIMO	ANT1	5240	NV	-20	-0.02	-3.816794	20	PASS
11AC20MIMO	ANT1	5240	NV	-10	-0.02	-3.816794	20	PASS
11AC20MIMO	ANT1	5240	NV	0	-0.02	-3.816794	20	PASS
11AC20MIMO	ANT1	5240	NV	10	-0.02	-3.816794	20	PASS
11AC20MIMO	ANT1	5240	NV	20	-0.02	-3.816794	20	PASS
11AC20MIMO	ANT1	5240	NV	30	-0.02	-3.816794	20	PASS
11AC20MIMO	ANT1	5240	NV	40	-0.02	-3.816794	20	PASS
11AC20MIMO	ANT1	5240	NV	50	0	0	20	PASS
11AC20MIMO	ANT2	5240	NV	-30	0	0	20	PASS
11AC20MIMO	ANT2	5240	NV	-20	0	0	20	PASS
11AC20MIMO	ANT2	5240	NV	-10	-0.02	-3.816794	20	PASS
11AC20MIMO	ANT2	5240	NV	0	-0.02	-3.816794	20	PASS
11AC20MIMO	ANT2	5240	NV	10	-0.02	-3.816794	20	PASS
11AC20MIMO	ANT2	5240	NV	20	-0.02	-3.816794	20	PASS
11AC20MIMO	ANT2	5240	NV	30	-0.02	-3.816794	20	PASS
11AC20MIMO	ANT2	5240	NV	40	-0.02	-3.816794	20	PASS
11AC20MIMO	ANT2	5240	NV	50	0	0	20	PASS
11AC20MIMO	ANT3	5240	NV	-30	-0.02	-3.816794	20	PASS
11AC20MIMO	ANT3	5240	NV	-20	-0.02	-3.816794	20	PASS
11AC20MIMO	ANT3	5240	NV	-10	-0.02	-3.816794	20	PASS
11AC20MIMO	ANT3	5240	NV	0	-0.02	-3.816794	20	PASS

11AC20MIMO	ANT3	5240	NV	10	-0.02	-3.816794	20	PASS
11AC20MIMO	ANT3	5240	NV	20	0	0	20	PASS
11AC20MIMO	ANT3	5240	NV	30	-0.02	-3.816794	20	PASS
11AC20MIMO	ANT3	5240	NV	40	0	0	20	PASS
11AC20MIMO	ANT3	5240	NV	50	0	0	20	PASS
11AC20MIMO	ANT1	5745	NV	-30	0	0	20	PASS
11AC20MIMO	ANT1	5745	NV	-20	0	0	20	PASS
11AC20MIMO	ANT1	5745	NV	-10	0	0	20	PASS
11AC20MIMO	ANT1	5745	NV	0	-0.02	-3.481288	20	PASS
11AC20MIMO	ANT1	5745	NV	10	0	0	20	PASS
11AC20MIMO	ANT1	5745	NV	20	0	0	20	PASS
11AC20MIMO	ANT1	5745	NV	30	0	0	20	PASS
11AC20MIMO	ANT1	5745	NV	40	0	0	20	PASS
11AC20MIMO	ANT1	5745	NV	50	-0.02	-3.481288	20	PASS
11AC20MIMO	ANT2	5745	NV	-30	0	0	20	PASS
11AC20MIMO	ANT2	5745	NV	-20	0	0	20	PASS
11AC20MIMO	ANT2	5745	NV	-10	0	0	20	PASS
11AC20MIMO	ANT2	5745	NV	0	0	0	20	PASS
11AC20MIMO	ANT2	5745	NV	10	0	0	20	PASS
11AC20MIMO	ANT2	5745	NV	20	0	0	20	PASS
11AC20MIMO	ANT2	5745	NV	30	0	0	20	PASS
11AC20MIMO	ANT2	5745	NV	40	0	0	20	PASS
11AC20MIMO	ANT2	5745	NV	50	0	0	20	PASS
11AC20MIMO	ANT3	5745	NV	-30	0	0	20	PASS
11AC20MIMO	ANT3	5745	NV	-20	-0.02	-3.481288	20	PASS
11AC20MIMO	ANT3	5745	NV	-10	-0.02	-3.481288	20	PASS
11AC20MIMO	ANT3	5745	NV	0	0	0	20	PASS
11AC20MIMO	ANT3	5745	NV	10	0	0	20	PASS
11AC20MIMO	ANT3	5745	NV	20	-0.02	-3.481288	20	PASS
11AC20MIMO	ANT3	5745	NV	30	0	0	20	PASS
11AC20MIMO	ANT3	5745	NV	40	-0.02	-3.481288	20	PASS
11AC20MIMO	ANT3	5745	NV	50	-0.02	-3.481288	20	PASS
11AC20MIMO	ANT1	5785	NV	-30	0	0	20	PASS
11AC20MIMO	ANT1	5785	NV	-20	0	0	20	PASS
11AC20MIMO	ANT1	5785	NV	-10	0	0	20	PASS
11AC20MIMO	ANT1	5785	NV	0	0	0	20	PASS
11AC20MIMO	ANT1	5785	NV	10	0	0	20	PASS
11AC20MIMO	ANT1	5785	NV	20	0	0	20	PASS
11AC20MIMO	ANT1	5785	NV	30	0	0	20	PASS
11AC20MIMO	ANT1	5785	NV	40	0	0	20	PASS
11AC20MIMO	ANT1	5785	NV	50	0	0	20	PASS
11AC20MIMO	ANT2	5785	NV	-30	0	0	20	PASS
11AC20MIMO	ANT2	5785	NV	-20	0	0	20	PASS
11AC20MIMO	ANT2	5785	NV	-10	0	0	20	PASS
11AC20MIMO	ANT2	5785	NV	0	0	0	20	PASS
11AC20MIMO	ANT2	5785	NV	10	0	0	20	PASS
11AC20MIMO	ANT2	5785	NV	20	0	0	20	PASS
11AC20MIMO	ANT2	5785	NV	30	0	0	20	PASS
11AC20MIMO	ANT2	5785	NV	40	0	0	20	PASS
11AC20MIMO	ANT2	5785	NV	50	0	0	20	PASS
11AC20MIMO	ANT3	5785	NV	-30	0	0	20	PASS

11AC20MIMO	ANT3	5785	NV	-20	0	0	20	PASS
11AC20MIMO	ANT3	5785	NV	-10	0	0	20	PASS
11AC20MIMO	ANT3	5785	NV	0	0	0	20	PASS
11AC20MIMO	ANT3	5785	NV	10	0	0	20	PASS
11AC20MIMO	ANT3	5785	NV	20	0	0	20	PASS
11AC20MIMO	ANT3	5785	NV	30	0	0	20	PASS
11AC20MIMO	ANT3	5785	NV	40	0	0	20	PASS
11AC20MIMO	ANT3	5785	NV	50	0	0	20	PASS
11AC20MIMO	ANT1	5825	NV	-30	-0.02	-3.433476	20	PASS
11AC20MIMO	ANT1	5825	NV	-20	-0.02	-3.433476	20	PASS
11AC20MIMO	ANT1	5825	NV	-10	-0.02	-3.433476	20	PASS
11AC20MIMO	ANT1	5825	NV	0	-0.02	-3.433476	20	PASS
11AC20MIMO	ANT1	5825	NV	10	0	0	20	PASS
11AC20MIMO	ANT1	5825	NV	20	0	0	20	PASS
11AC20MIMO	ANT1	5825	NV	30	-0.02	-3.433476	20	PASS
11AC20MIMO	ANT1	5825	NV	40	-0.02	-3.433476	20	PASS
11AC20MIMO	ANT1	5825	NV	50	-0.02	-3.433476	20	PASS
11AC20MIMO	ANT2	5825	NV	-30	0	0	20	PASS
11AC20MIMO	ANT2	5825	NV	-20	0	0	20	PASS
11AC20MIMO	ANT2	5825	NV	-10	-0.02	-3.433476	20	PASS
11AC20MIMO	ANT2	5825	NV	0	0	0	20	PASS
11AC20MIMO	ANT2	5825	NV	10	-0.02	-3.433476	20	PASS
11AC20MIMO	ANT2	5825	NV	20	0	0	20	PASS
11AC20MIMO	ANT2	5825	NV	30	-0.02	-3.433476	20	PASS
11AC20MIMO	ANT2	5825	NV	40	-0.02	-3.433476	20	PASS
11AC20MIMO	ANT2	5825	NV	50	0	0	20	PASS
11AC20MIMO	ANT3	5825	NV	-30	0	0	20	PASS
11AC20MIMO	ANT3	5825	NV	-20	0	0	20	PASS
11AC20MIMO	ANT3	5825	NV	-10	0.02	3.433476	20	PASS
11AC20MIMO	ANT3	5825	NV	0	0	0	20	PASS
11AC20MIMO	ANT3	5825	NV	10	0	0	20	PASS
11AC20MIMO	ANT3	5825	NV	20	0	0	20	PASS
11AC20MIMO	ANT3	5825	NV	30	-0.02	-3.433476	20	PASS
11AC20MIMO	ANT3	5825	NV	40	0	0	20	PASS
11AC20MIMO	ANT3	5825	NV	50	0	0	20	PASS
11AC40MIMO	ANT1	5190	NV	-30	-0.04	-7.707129	20	PASS
11AC40MIMO	ANT1	5190	NV	-20	-0.04	-7.707129	20	PASS
11AC40MIMO	ANT1	5190	NV	-10	-0.04	-7.707129	20	PASS
11AC40MIMO	ANT1	5190	NV	0	-0.04	-7.707129	20	PASS
11AC40MIMO	ANT1	5190	NV	10	0	0	20	PASS
11AC40MIMO	ANT1	5190	NV	20	-0.04	-7.707129	20	PASS
11AC40MIMO	ANT1	5190	NV	30	-0.04	-7.707129	20	PASS
11AC40MIMO	ANT1	5190	NV	40	-0.04	-7.707129	20	PASS
11AC40MIMO	ANT1	5190	NV	50	-0.04	-7.707129	20	PASS
11AC40MIMO	ANT2	5190	NV	-30	-0.04	-7.707129	20	PASS
11AC40MIMO	ANT2	5190	NV	-20	-0.04	-7.707129	20	PASS
11AC40MIMO	ANT2	5190	NV	-10	-0.04	-7.707129	20	PASS
11AC40MIMO	ANT2	5190	NV	0	-0.04	-7.707129	20	PASS
11AC40MIMO	ANT2	5190	NV	10	-0.04	-7.707129	20	PASS
11AC40MIMO	ANT2	5190	NV	20	-0.04	-7.707129	20	PASS
11AC40MIMO	ANT2	5190	NV	30	-0.04	-7.707129	20	PASS

11AC40MIMO	ANT2	5190	NV	40	-0.04	-7.707129	20	PASS
11AC40MIMO	ANT2	5190	NV	50	-0.04	-7.707129	20	PASS
11AC40MIMO	ANT3	5190	NV	-30	0	0	20	PASS
11AC40MIMO	ANT3	5190	NV	-20	-0.04	-7.707129	20	PASS
11AC40MIMO	ANT3	5190	NV	-10	-0.04	-7.707129	20	PASS
11AC40MIMO	ANT3	5190	NV	0	-0.04	-7.707129	20	PASS
11AC40MIMO	ANT3	5190	NV	10	0	0	20	PASS
11AC40MIMO	ANT3	5190	NV	20	0	0	20	PASS
11AC40MIMO	ANT3	5190	NV	30	-0.04	-7.707129	20	PASS
11AC40MIMO	ANT3	5190	NV	40	-0.04	-7.707129	20	PASS
11AC40MIMO	ANT3	5190	NV	50	-0.04	-7.707129	20	PASS
11AC40MIMO	ANT1	5230	NV	-30	-0.02	-3.824092	20	PASS
11AC40MIMO	ANT1	5230	NV	-20	-0.02	-3.824092	20	PASS
11AC40MIMO	ANT1	5230	NV	-10	-0.02	-3.824092	20	PASS
11AC40MIMO	ANT1	5230	NV	0	-0.02	-3.824092	20	PASS
11AC40MIMO	ANT1	5230	NV	10	-0.02	-3.824092	20	PASS
11AC40MIMO	ANT1	5230	NV	20	-0.02	-3.824092	20	PASS
11AC40MIMO	ANT1	5230	NV	30	-0.02	-3.824092	20	PASS
11AC40MIMO	ANT1	5230	NV	40	-0.02	-3.824092	20	PASS
11AC40MIMO	ANT1	5230	NV	50	-0.02	-3.824092	20	PASS
11AC40MIMO	ANT2	5230	NV	-30	-0.04	-7.648184	20	PASS
11AC40MIMO	ANT2	5230	NV	-20	0	0	20	PASS
11AC40MIMO	ANT2	5230	NV	-10	-0.04	-7.648184	20	PASS
11AC40MIMO	ANT2	5230	NV	0	-0.04	-7.648184	20	PASS
11AC40MIMO	ANT2	5230	NV	10	0	0	20	PASS
11AC40MIMO	ANT2	5230	NV	20	0	0	20	PASS
11AC40MIMO	ANT2	5230	NV	30	-0.04	-7.648184	20	PASS
11AC40MIMO	ANT2	5230	NV	40	-0.04	-7.648184	20	PASS
11AC40MIMO	ANT2	5230	NV	50	0	0	20	PASS
11AC40MIMO	ANT3	5230	NV	-30	-0.02	-3.824092	20	PASS
11AC40MIMO	ANT3	5230	NV	-20	-0.02	-3.824092	20	PASS
11AC40MIMO	ANT3	5230	NV	-10	-0.02	-3.824092	20	PASS
11AC40MIMO	ANT3	5230	NV	0	-0.02	-3.824092	20	PASS
11AC40MIMO	ANT3	5230	NV	10	-0.02	-3.824092	20	PASS
11AC40MIMO	ANT3	5230	NV	20	-0.02	-3.824092	20	PASS
11AC40MIMO	ANT3	5230	NV	30	-0.02	-3.824092	20	PASS
11AC40MIMO	ANT3	5230	NV	40	-0.02	-3.824092	20	PASS
11AC40MIMO	ANT3	5230	NV	50	-0.02	-3.824092	20	PASS
11AC40MIMO	ANT1	5755	NV	-30	0	0	20	PASS
11AC40MIMO	ANT1	5755	NV	-20	0.06	10.425717	20	PASS
11AC40MIMO	ANT1	5755	NV	-10	0.06	10.425717	20	PASS
11AC40MIMO	ANT1	5755	NV	0	0	0	20	PASS
11AC40MIMO	ANT1	5755	NV	10	0	0	20	PASS
11AC40MIMO	ANT1	5755	NV	20	0	0	20	PASS
11AC40MIMO	ANT1	5755	NV	30	0	0	20	PASS
11AC40MIMO	ANT1	5755	NV	40	0	0	20	PASS
11AC40MIMO	ANT1	5755	NV	50	0.06	10.425717	20	PASS
11AC40MIMO	ANT2	5755	NV	-30	-0.04	-6.950478	20	PASS
11AC40MIMO	ANT2	5755	NV	-20	-0.04	-6.950478	20	PASS
11AC40MIMO	ANT2	5755	NV	-10	-0.04	-6.950478	20	PASS
11AC40MIMO	ANT2	5755	NV	0	-0.04	-6.950478	20	PASS

11AC40MIMO	ANT2	5755	NV	10	-0.04	-6.950478	20	PASS
11AC40MIMO	ANT2	5755	NV	20	-0.04	-6.950478	20	PASS
11AC40MIMO	ANT2	5755	NV	30	-0.04	-6.950478	20	PASS
11AC40MIMO	ANT2	5755	NV	40	-0.04	-6.950478	20	PASS
11AC40MIMO	ANT2	5755	NV	50	-0.04	-6.950478	20	PASS
11AC40MIMO	ANT3	5755	NV	-30	-0.04	-6.950478	20	PASS
11AC40MIMO	ANT3	5755	NV	-20	-0.04	-6.950478	20	PASS
11AC40MIMO	ANT3	5755	NV	-10	-0.04	-6.950478	20	PASS
11AC40MIMO	ANT3	5755	NV	0	-0.04	-6.950478	20	PASS
11AC40MIMO	ANT3	5755	NV	10	-0.04	-6.950478	20	PASS
11AC40MIMO	ANT3	5755	NV	20	-0.04	-6.950478	20	PASS
11AC40MIMO	ANT3	5755	NV	30	-0.04	-6.950478	20	PASS
11AC40MIMO	ANT3	5755	NV	40	-0.04	-6.950478	20	PASS
11AC40MIMO	ANT3	5755	NV	50	-0.04	-6.950478	20	PASS
11AC40MIMO	ANT1	5795	NV	-30	-0.02	-3.451251	20	PASS
11AC40MIMO	ANT1	5795	NV	-20	-0.02	-3.451251	20	PASS
11AC40MIMO	ANT1	5795	NV	-10	-0.02	-3.451251	20	PASS
11AC40MIMO	ANT1	5795	NV	0	-0.02	-3.451251	20	PASS
11AC40MIMO	ANT1	5795	NV	10	-0.02	-3.451251	20	PASS
11AC40MIMO	ANT1	5795	NV	20	-0.02	-3.451251	20	PASS
11AC40MIMO	ANT1	5795	NV	30	-0.02	-3.451251	20	PASS
11AC40MIMO	ANT1	5795	NV	40	-0.02	-3.451251	20	PASS
11AC40MIMO	ANT1	5795	NV	50	-0.02	-3.451251	20	PASS
11AC40MIMO	ANT2	5795	NV	-30	-0.04	-6.902502	20	PASS
11AC40MIMO	ANT2	5795	NV	-20	-0.04	-6.902502	20	PASS
11AC40MIMO	ANT2	5795	NV	-10	-0.04	-6.902502	20	PASS
11AC40MIMO	ANT2	5795	NV	0	-0.04	-6.902502	20	PASS
11AC40MIMO	ANT2	5795	NV	10	-0.04	-6.902502	20	PASS
11AC40MIMO	ANT2	5795	NV	20	-0.04	-6.902502	20	PASS
11AC40MIMO	ANT2	5795	NV	30	-0.04	-6.902502	20	PASS
11AC40MIMO	ANT2	5795	NV	40	-0.04	-6.902502	20	PASS
11AC40MIMO	ANT2	5795	NV	50	-0.04	-6.902502	20	PASS
11AC40MIMO	ANT3	5795	NV	-30	-0.04	-6.902502	20	PASS
11AC40MIMO	ANT3	5795	NV	-20	-0.04	-6.902502	20	PASS
11AC40MIMO	ANT3	5795	NV	-10	-0.04	-6.902502	20	PASS
11AC40MIMO	ANT3	5795	NV	0	-0.04	-6.902502	20	PASS
11AC40MIMO	ANT3	5795	NV	10	-0.04	-6.902502	20	PASS
11AC40MIMO	ANT3	5795	NV	20	0	0	20	PASS
11AC40MIMO	ANT3	5795	NV	30	-0.04	-6.902502	20	PASS
11AC40MIMO	ANT3	5795	NV	40	-0.04	-6.902502	20	PASS
11AC40MIMO	ANT3	5795	NV	50	-0.04	-6.902502	20	PASS
11AC80MIMO	ANT1	5210	NV	-30	0	0	20	PASS
11AC80MIMO	ANT1	5210	NV	-20	0	0	20	PASS
11AC80MIMO	ANT1	5210	NV	-10	0	0	20	PASS
11AC80MIMO	ANT1	5210	NV	0	0	0	20	PASS
11AC80MIMO	ANT1	5210	NV	10	0	0	20	PASS
11AC80MIMO	ANT1	5210	NV	20	0	0	20	PASS
11AC80MIMO	ANT1	5210	NV	30	0	0	20	PASS
11AC80MIMO	ANT1	5210	NV	40	0	0	20	PASS
11AC80MIMO	ANT1	5210	NV	50	0	0	20	PASS
11AC80MIMO	ANT2	5210	NV	-30	0	0	20	PASS



11AC80MIMO	ANT2	5210	NV	-20	0	0	20	PASS
11AC80MIMO	ANT2	5210	NV	-10	0	0	20	PASS
11AC80MIMO	ANT2	5210	NV	0	0	0	20	PASS
11AC80MIMO	ANT2	5210	NV	10	0	0	20	PASS
11AC80MIMO	ANT2	5210	NV	20	0	0	20	PASS
11AC80MIMO	ANT2	5210	NV	30	0	0	20	PASS
11AC80MIMO	ANT2	5210	NV	40	0	0	20	PASS
11AC80MIMO	ANT2	5210	NV	50	0	0	20	PASS
11AC80MIMO	ANT3	5210	NV	-30	0	0	20	PASS
11AC80MIMO	ANT3	5210	NV	-20	0	0	20	PASS
11AC80MIMO	ANT3	5210	NV	-10	0	0	20	PASS
11AC80MIMO	ANT3	5210	NV	0	0	0	20	PASS
11AC80MIMO	ANT3	5210	NV	10	0	0	20	PASS
11AC80MIMO	ANT3	5210	NV	20	0	0	20	PASS
11AC80MIMO	ANT3	5210	NV	30	0	0	20	PASS
11AC80MIMO	ANT3	5210	NV	40	0	0	20	PASS
11AC80MIMO	ANT3	5210	NV	50	0	0	20	PASS
11AC80MIMO	ANT1	5775	NV	-30	0	0	20	PASS
11AC80MIMO	ANT1	5775	NV	-20	0	0	20	PASS
11AC80MIMO	ANT1	5775	NV	-10	0	0	20	PASS
11AC80MIMO	ANT1	5775	NV	0	0	0	20	PASS
11AC80MIMO	ANT1	5775	NV	10	0	0	20	PASS
11AC80MIMO	ANT1	5775	NV	20	0	0	20	PASS
11AC80MIMO	ANT1	5775	NV	30	0	0	20	PASS
11AC80MIMO	ANT1	5775	NV	40	0	0	20	PASS
11AC80MIMO	ANT1	5775	NV	50	0	0	20	PASS
11AC80MIMO	ANT2	5775	NV	-30	0	0	20	PASS
11AC80MIMO	ANT2	5775	NV	-20	0	0	20	PASS
11AC80MIMO	ANT2	5775	NV	-10	0	0	20	PASS
11AC80MIMO	ANT2	5775	NV	0	0	0	20	PASS
11AC80MIMO	ANT2	5775	NV	10	0	0	20	PASS
11AC80MIMO	ANT2	5775	NV	20	0	0	20	PASS
11AC80MIMO	ANT2	5775	NV	30	0	0	20	PASS
11AC80MIMO	ANT2	5775	NV	40	0	0	20	PASS
11AC80MIMO	ANT2	5775	NV	50	0	0	20	PASS
11AC80MIMO	ANT3	5775	NV	-30	0	0	20	PASS
11AC80MIMO	ANT3	5775	NV	-20	0	0	20	PASS
11AC80MIMO	ANT3	5775	NV	-10	0	0	20	PASS
11AC80MIMO	ANT3	5775	NV	0	0	0	20	PASS
11AC80MIMO	ANT3	5775	NV	10	0	0	20	PASS
11AC80MIMO	ANT3	5775	NV	20	-0.08	-13.852814	20	PASS
11AC80MIMO	ANT3	5775	NV	30	0	0	20	PASS
11AC80MIMO	ANT3	5775	NV	40	0	0	20	PASS
11AC80MIMO	ANT3	5775	NV	50	0	0	20	PASS
11ASISO	ANT1	5180	NV	-30	-0.02	-3.861004	20	PASS
11ASISO	ANT1	5180	NV	-20	-0.02	-3.861004	20	PASS
11ASISO	ANT1	5180	NV	-10	-0.02	-3.861004	20	PASS
11ASISO	ANT1	5180	NV	0	-0.02	-3.861004	20	PASS
11ASISO	ANT1	5180	NV	10	-0.02	-3.861004	20	PASS
11ASISO	ANT1	5180	NV	20	-0.02	-3.861004	20	PASS
11ASISO	ANT1	5180	NV	30	-0.02	-3.861004	20	PASS

11ASISO	ANT1	5180	NV	40	-0.02	-3.861004	20	PASS
11ASISO	ANT1	5180	NV	50	-0.02	-3.861004	20	PASS
11ASISO	ANT1	5200	NV	-30	-0.02	-3.846154	20	PASS
11ASISO	ANT1	5200	NV	-20	-0.02	-3.846154	20	PASS
11ASISO	ANT1	5200	NV	-10	-0.02	-3.846154	20	PASS
11ASISO	ANT1	5200	NV	0	-0.02	-3.846154	20	PASS
11ASISO	ANT1	5200	NV	10	-0.02	-3.846154	20	PASS
11ASISO	ANT1	5200	NV	20	-0.02	-3.846154	20	PASS
11ASISO	ANT1	5200	NV	30	-0.02	-3.846154	20	PASS
11ASISO	ANT1	5200	NV	40	-0.02	-3.846154	20	PASS
11ASISO	ANT1	5200	NV	50	-0.02	-3.846154	20	PASS
11ASISO	ANT1	5240	NV	-30	-0.02	-3.816794	20	PASS
11ASISO	ANT1	5240	NV	-20	-0.02	-3.816794	20	PASS
11ASISO	ANT1	5240	NV	-10	-0.02	-3.816794	20	PASS
11ASISO	ANT1	5240	NV	0	-0.02	-3.816794	20	PASS
11ASISO	ANT1	5240	NV	10	-0.02	-3.816794	20	PASS
11ASISO	ANT1	5240	NV	20	-0.02	-3.816794	20	PASS
11ASISO	ANT1	5240	NV	30	-0.02	-3.816794	20	PASS
11ASISO	ANT1	5240	NV	40	-0.02	-3.816794	20	PASS
11ASISO	ANT1	5240	NV	50	-0.02	-3.816794	20	PASS
11ASISO	ANT1	5745	NV	-30	0	0	20	PASS
11ASISO	ANT1	5745	NV	-20	0	0	20	PASS
11ASISO	ANT1	5745	NV	-10	0	0	20	PASS
11ASISO	ANT1	5745	NV	0	0	0	20	PASS
11ASISO	ANT1	5745	NV	10	0	0	20	PASS
11ASISO	ANT1	5745	NV	20	0	0	20	PASS
11ASISO	ANT1	5745	NV	30	0	0	20	PASS
11ASISO	ANT1	5745	NV	40	0	0	20	PASS
11ASISO	ANT1	5745	NV	50	0	0	20	PASS
11ASISO	ANT1	5785	NV	-30	-0.02	-3.457217	20	PASS
11ASISO	ANT1	5785	NV	-20	-0.02	-3.457217	20	PASS
11ASISO	ANT1	5785	NV	-10	-0.02	-3.457217	20	PASS
11ASISO	ANT1	5785	NV	0	-0.02	-3.457217	20	PASS
11ASISO	ANT1	5785	NV	10	-0.02	-3.457217	20	PASS
11ASISO	ANT1	5785	NV	20	0	0	20	PASS
11ASISO	ANT1	5785	NV	30	-0.02	-3.457217	20	PASS
11ASISO	ANT1	5785	NV	40	-0.02	-3.457217	20	PASS
11ASISO	ANT1	5785	NV	50	-0.02	-3.457217	20	PASS
11ASISO	ANT1	5825	NV	-30	-0.02	-3.433476	20	PASS
11ASISO	ANT1	5825	NV	-20	-0.02	-3.433476	20	PASS
11ASISO	ANT1	5825	NV	-10	-0.02	-3.433476	20	PASS
11ASISO	ANT1	5825	NV	0	-0.02	-3.433476	20	PASS
11ASISO	ANT1	5825	NV	10	-0.02	-3.433476	20	PASS
11ASISO	ANT1	5825	NV	20	-0.02	-3.433476	20	PASS
11ASISO	ANT1	5825	NV	30	-0.02	-3.433476	20	PASS
11ASISO	ANT1	5825	NV	40	-0.02	-3.433476	20	PASS
11ASISO	ANT1	5825	NV	50	-0.02	-3.433476	20	PASS

## 8. Emissions in restricted frequency bands

### 8.1. Block diagram of test setup

In 3m Anechoic Chamber Test Setup Diagram for 9kHz-30MHz

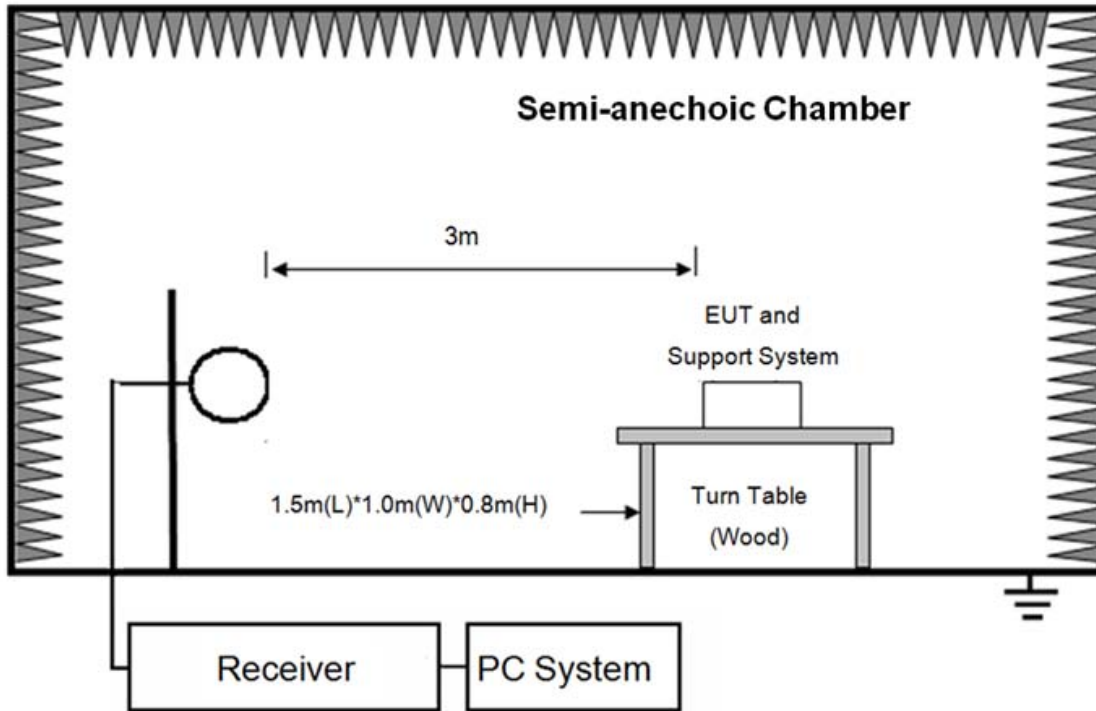

In 3m Anechoic Chamber Test Setup Diagram for 30MHz-1GHz

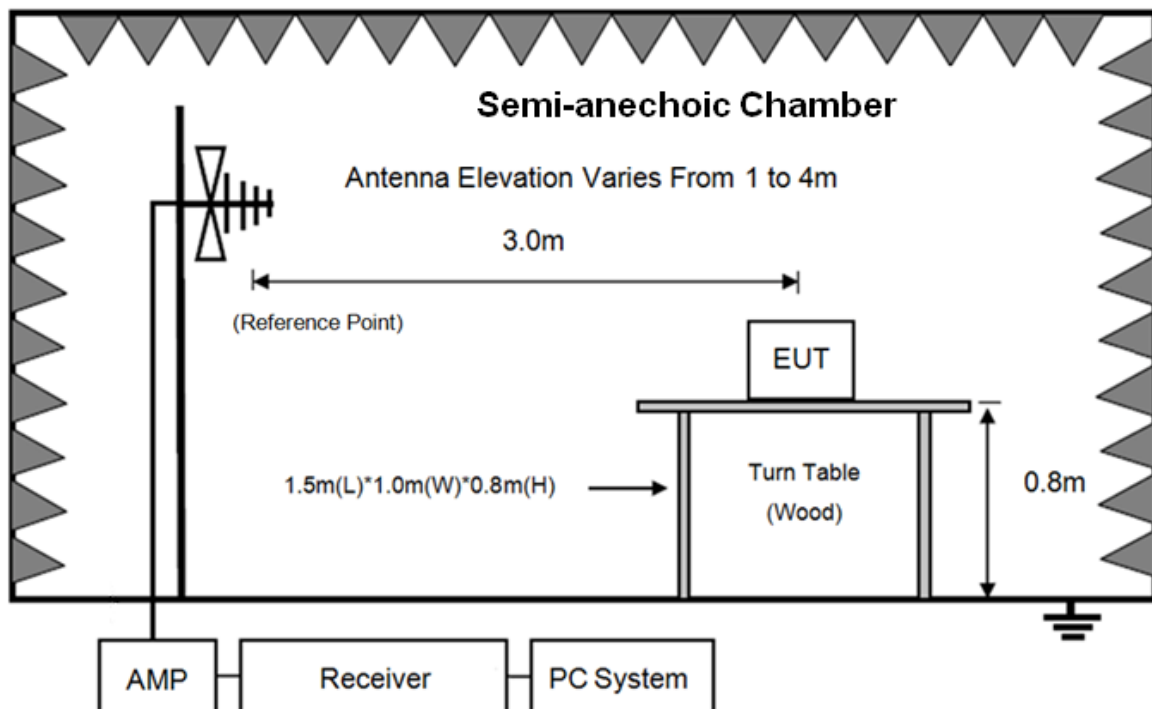

In 3m Anechoic Chamber Test Setup Diagram for frequency above 1GHz

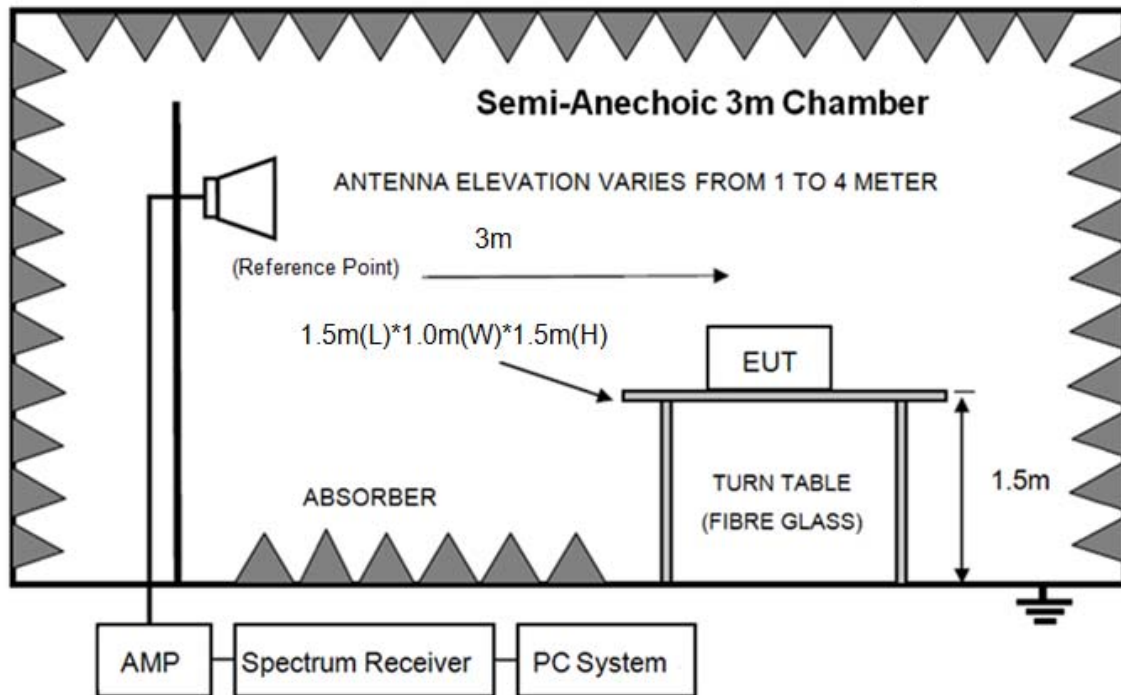

Note: For harmonic emissions test a appropriate high pass filter was inserted in the input port of AMP.

**8.2. Limit**

8.3.1 FCC 15.205 Restricted frequency band

MHz	MHz	MHz	GHz
0.090-0.110	16.42-16.423	399.9-410	4.5-5.15
10.495-0.505	16.69475-16.69525	608-614	5.35-5.46
2.1735-2.1905	16.80425-16.80475	960-1240	7.25-7.75
4.125-4.128	25.5-25.67	1300-1427	8.025-8.5
4.1772&4.1775	37.5-38.25	1435-1626.5	9.0-9.2
4.2072&4.2075	73-74.6	1645.5-1646.5	9.3-9.5
6.215-6.218	74.8-75.2	1660-1710	10.6-12.7
6.26775-6.26825	108-121.94	1718.8-1722.2	13.25-13.4
6.31175-6.31225	123-138	2200-2300	14.47-14.5
8.291-8.294	149.9-150.05	2310-2390	15.35-16.2
8.362-8.366	156.52475-156.52525	2483.5-2500	17.7-21.4
8.37625-8.38675	156.7-156.9	2690-2900	22.01-23.12
8.41425-8.41475	162.0125-167.17	3260-3267	23.6-24.G
12.29-12.293	167.72-173.2	3332-3339	31.2-31.8
12.51975-12.52025	240-285	3345.8-3358	36.43-36.5
12.57675-12.57725	322-335.4	3600-4400	( <sup>2</sup> )
13.36-13.41			

## 8.3.2 FCC 15.209 Limit.

FREQUENCY MHz	DISTANCE Meters	FIELD STRENGTHS LIMIT	
		$\mu\text{V}/\text{m}$	$\text{dB}(\mu\text{V})/\text{m}$
0.009 ~ 0.490	300	2400/F(kHz)	67.6-20log(F)
0.490 ~ 1.705	30	24000/F(kHz)	87.6-20log(F)
1.705 ~ 30.0	30	30	29.54
30 ~ 88	3	100	40.0
88 ~ 216	3	150	43.5
216 ~ 960	3	200	46.0
960 ~ 1000	3	500	54.0
Above 1000	3	74.0 $\text{dB}(\mu\text{V})/\text{m}$ (Peak) 54.0 $\text{dB}(\mu\text{V})/\text{m}$ (Average)	

Note: (1)The emission limits shown in the above table are based on measurements employing a CISPR QP detector except for the frequency bands 9-90kHz, 110-490kHz and above 1000MHz. Radiated emissions limits in these three bands are based on measurements employing an average detector.

(2) At frequencies below 30MHz, measurement may be performed at a distance closer than that specified, and the limit at closer measurement distance can be extrapolated by below formula:

$$\text{Limit}_{3\text{m}}(\text{dB}\mu\text{V}/\text{m}) = \text{Limit}_{30\text{m}}(\text{dB}\mu\text{V}/\text{m}) + 40\text{Log}(30\text{m}/3\text{m})$$

## 8.3.3 Limit for this EUT

All the emissions appearing within 15.205 restricted frequency bands shall not exceed the limits shown in 15.209, all the other emissions shall be at least 20dB below the fundamental emissions, or comply with 15.209 limits.

**8.3. Test Procedure**

- (1) EUT height should be 0.8m for below 1GHz at a semi - anechoic chamber while EUT height should be 1.5m for above 1GHz at full chamber or semi - anechoic chamber ground with absorbers
- (2) Setup EUT and assistant system according clause 2.3 and 8.2
- (3) Test antenna was located 3m from the EUT on an adjustable mast, and the antenna used as below table.

Test frequency range	Test antenna used	Test distance
9kHz-30MHz	Active Loop antenna	3m
30MHz-1GHz	Trilog Broadband Antenna	3m
1GHz-18GHz	Double Ridged Horn Antenna(1GHz-18GHz)	3m
18GHz-40GHz	Horn Antenna(18GHz-40GHz)	1m

According ANSI C63.10:2013 clause 6.4.4.2 and 6.5.3, for measurements below 30 MHz, the loop antenna was positioned with its plane vertical from the EUT and rotated about its vertical

axis for maximum response at each azimuth position around the EUT. And the loop antenna also be positioned with its plane horizontal at the specified distance from the EUT. The center of the loop is 1 m above the ground. for measurement above 30MHz, the Trilog Broadband Antenna or Horn Antenna was located 3m from EUT, Measurements were made with the antenna positioned in both the horizontal and vertical planes of Polarization, and the measurement antenna was varied from 1 m to 4 m. in height above the reference ground plane to obtain the maximum signal strength.

(4) Below pre-scan procedure was first performed in order to find prominent frequency spectrum radiated emissions from 9kHz to 40GHz:

(a) Scanning the peak frequency spectrum with the antenna specified in step (3), and the EUT was rotated 360 degree, the antenna height was varied from 1m to 4m(Except loop antenna, it's fixed 1m above ground.)

(b) Change work frequency or channel of device if practicable.

(c) Change modulation type of device if practicable.

(d) Change power supply range from 85% to 115% of the rated supply voltage

(e) Rotated EUT though three orthogonal axes to determine the attitude of EUT arrangement produces highest emissions.

Spectrum frequency from 9kHz to 40GHz (tenth harmonic of fundamental frequency) was investigated, and no any obvious emission were detected from 9kHz to 30MHz and 18GHz to 40GHz, so below final test was performed with frequency range from 30MHz to 18GHz.

(5) For final emissions measurements at each frequency of interest, the EUT was rotated and the antenna height was varied between 1m and 4m in order to maximize the emission. Measurements in both horizontal and vertical polarities were made and the data was recorded. In order to find the maximum emission, the relative positions of equipments and all of the interface cables were changed according to ANSI C63.10 2013 on Radiated Emission test.

(6) The emissions from 9kHz to 1GHz were measured based on CISPR QP detector except for the frequency bands 9-90kHz, 110-490kHz, for emissions from 9kHz-90kHz,110kHz-490kHz and above 1GHz were measured based on average detector, for emissions above 1GHz, peak emissions also be measured and need comply with Peak limit.

(7) The emissions from 9kHz to 1GHz, QP or average values were measured with EMI receiver with below RBW

Frequency band	RBW
9kHz-150kHz	200Hz
150kHz-30MHz	9kHz
30MHz-1GHz	120kHz

(8) For emissions above 1GHz, both Peak and Average level were measured with Spectrum Analyzer, and the RBW is set at 1MHz, VBW is set at 3MHz ,Peak detector for Peak measure , RMS detector for AV value

## 8.4. Test result

### **PASS. (See below detailed test result)**

All the emissions except fundamental emission from 9kHz to 40GHz were comply with 15.209 limit.

Note1: According exploratory test no any obvious emission were detected from 9kHz to 30MHz and 18GHz to 40GHz, so the final test was performed with frequency range from 30MHz to 18GHz and recorded in below.

Note2: For emissions below 1GHz, according exploratory explorer test, when change Tx mode and channel, have no distinct influence on emissions level, so for emissions below 1GHz, the final test was only performed with EUT working in 11a mode.

Note3: For emissions above 1GHz, 11a ANT1, 11n20, n40, 11ac20, 11ac40, 11ac80 mode ANT 1 ANT 2 ANT 3 mode and MIMO mode all have been tested, only 11a ANT 1 mode is the worst case and reported

## Radiated Emission test (below 1GHz) TR-4-E-009 Radiated Emission Test Result

<b>Test Site</b>	: DDT 3m Chamber 1#	D:\2018 RE1# Report Data\Q18030203-1E GPON SFU	ONT\RF.EM6
<b>Test Date</b>	: 2018-03-22	<b>Tested By</b>	: Sunny
<b>EUT</b>	: GPON SFU ONT	<b>Model Number</b>	: 7285G
<b>Power Supply</b>	: AC 120V/60Hz	<b>Test Mode</b>	: Tx mode
<b>Condition</b>	: Temp:24.5'C,Humi:55%, Press:100.1kPa	<b>Antenna/Distance</b>	: 2017 VULB 9163 1#/3m/HORIZONTAL
<b>Memo</b>	:		

Data: 3

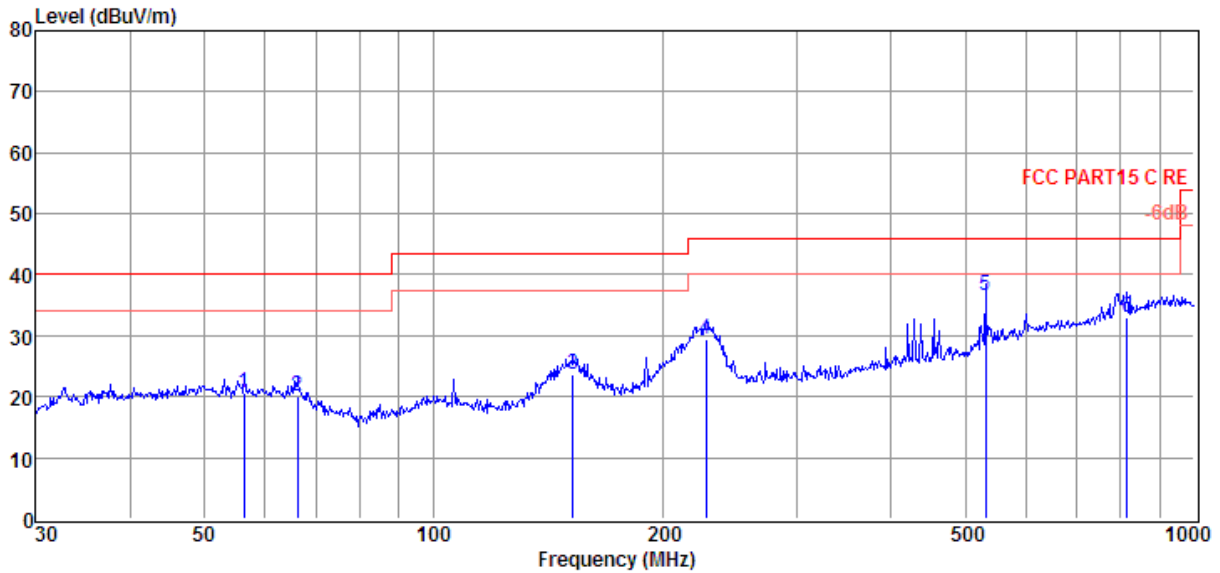

Item (Mark)	Freq. (MHz)	Read Level (dBμV)	Antenna Factor (dB/m)	Cable Loss dB	Result Level (dBμV/m)	Limit Line (dBμV/m)	Over Limit (dB)	Detector	Polarization
1	56.40	4.46	12.22	4.06	20.74	40.00	-19.26	QP	HORIZONTAL
2	66.27	6.06	9.98	4.15	20.19	40.00	-19.81	QP	HORIZONTAL
3	152.66	10.62	8.18	4.78	23.58	43.50	-19.92	QP	HORIZONTAL
4	228.49	12.25	12.09	5.18	29.52	46.00	-16.48	QP	HORIZONTAL
5	531.96	12.51	18.15	5.78	36.44	46.00	-9.56	QP	HORIZONTAL
6	815.97	4.21	21.52	7.36	33.09	46.00	-12.91	QP	HORIZONTAL

- Note: 1. Result Level = Read Level + Antenna Factor + Cable loss.  
 2. If Peak Result complies with QP limit, QP Result is deemed to comply with QP limit.  
 3. Test setup: RBW: 120 kHz, VBW: 300 kHz, Sweep time: auto.



# TR-4-E-009 Radiated Emission Test Result

<b>Test Site</b>	: DDT 3m Chamber 1#	D:\2018 RE1# Report Data\Q18030203-1E GPON SFU ONT\RF.EM6
<b>Test Date</b>	: 2018-03-22	<b>Tested By</b> : Sunny
<b>EUT</b>	: GPON SFU ONT	<b>Model Number</b> : 7285G
<b>Power Supply</b>	: AC 120V/60Hz	<b>Test Mode</b> : Tx mode
<b>Condition</b>	: Temp:24.5'C,Humi:55%, Press:100.1kPa	<b>Antenna/Distance</b> : 2017 VULB 9163 1#/3m/VERTICAL
<b>Memo</b>	:	

Data: 4

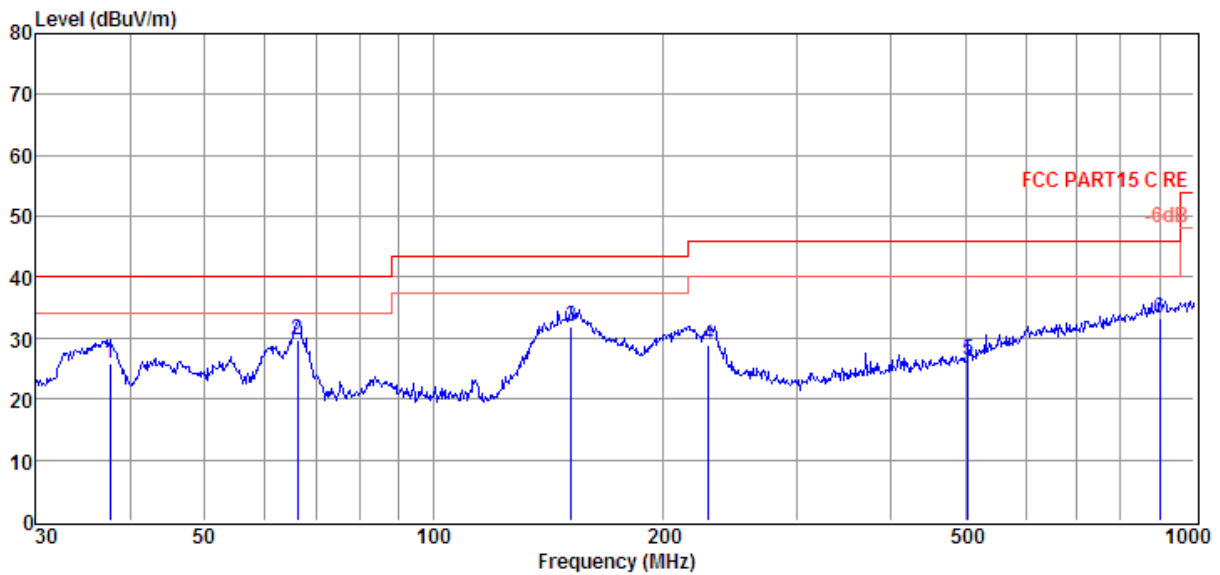

Item (Mark)	Freq. (MHz)	Read Level (dBμV)	Antenna Factor (dB/m)	Cable Loss (dB)	Result Level (dBμV/m)	Limit Line (dBμV/m)	Over Limit (dB)	Detector	Polarization
1	37.55	9.81	12.12	3.85	25.78	40.00	-14.22	QP	VERTICAL
2	66.27	15.60	9.98	4.15	29.73	40.00	-10.27	QP	VERTICAL
3	151.60	19.05	8.12	4.78	31.95	43.50	-11.55	QP	VERTICAL
4	230.10	11.67	12.12	5.19	28.98	46.00	-17.02	QP	VERTICAL
5	504.71	3.50	17.60	5.39	26.49	46.00	-19.51	QP	VERTICAL
6	900.15	3.00	22.60	7.60	33.20	46.00	-12.80	QP	VERTICAL

- Note: 1. Result Level = Read Level + Antenna Factor + Cable loss.  
 2. If Peak Result complies with QP limit, QP Result is deemed to comply with QP limit.  
 3. Test setup: RBW: 120 kHz, VBW: 300 kHz, Sweep time: auto.

**Radiated Emission test (above 1GHz)**

Freq (MHz)	Read level (dB $\mu$ V)	Antenna Factor (dB/m)	PRM Factor (dB)	Cable Loss (dB)	Result Level (dB $\mu$ V/m)	Limit (dB $\mu$ V/m)	Margin (dB)	Detector type	Polarization
<b>11a CH36</b>									
5250.00	42.79	35.25	43.65	7.74	42.13	68.20	-26.07	Peak	HORIZONTAL
7511.00	40.44	37.00	43.65	8.79	42.58	68.20	-25.62	Peak	HORIZONTAL
8956.00	40.75	37.48	44.09	10.32	44.46	68.20	-23.74	Peak	HORIZONTAL
9959.00	40.01	38.16	44.39	10.87	44.65	68.20	-23.55	Peak	HORIZONTAL
11285.00	40.05	38.69	44.21	11.03	45.56	68.20	-22.64	Peak	HORIZONTAL
13070.00	39.47	39.37	44.37	11.42	45.89	68.20	-22.31	Peak	HORIZONTAL
6219.00	40.53	35.70	43.27	8.24	41.20	68.20	-27.00	Peak	VERTICAL
7035.00	40.46	36.81	43.51	8.36	42.12	68.20	-26.08	Peak	VERTICAL
8871.00	39.03	37.45	44.06	10.22	42.64	68.20	-25.56	Peak	VERTICAL
10095.00	39.85	38.26	44.39	10.91	44.63	68.20	-23.57	Peak	VERTICAL
10979.00	39.15	38.79	44.25	11.06	44.75	68.20	-23.45	Peak	VERTICAL
12220.00	39.86	38.86	44.15	11.05	45.62	68.20	-22.58	Peak	VERTICAL
<b>11a CH40</b>									
5250.00	42.79	35.25	43.65	7.74	42.13	68.20	-26.07	Peak	HORIZONTAL
7511.00	40.44	37.00	43.65	8.79	42.58	68.20	-25.62	Peak	HORIZONTAL
8956.00	40.75	37.48	44.09	10.32	44.46	68.20	-23.74	Peak	HORIZONTAL
9959.00	40.01	38.16	44.39	10.87	44.65	68.20	-23.55	Peak	HORIZONTAL
11285.00	40.05	38.69	44.21	11.03	45.56	68.20	-22.64	Peak	HORIZONTAL
13070.00	39.47	39.37	44.37	11.42	45.89	68.20	-22.31	Peak	HORIZONTAL
5675.00	42.58	35.57	43.40	8.01	42.76	68.20	-25.44	Peak	VERTICAL
7086.00	40.49	36.83	43.53	8.41	42.20	68.20	-26.00	Peak	VERTICAL
8990.00	39.91	37.50	44.10	10.36	43.67	68.20	-24.53	Peak	VERTICAL
10826.00	39.06	38.70	44.28	11.03	44.51	68.20	-23.69	Peak	VERTICAL
11744.00	39.30	38.75	44.14	10.99	44.90	68.20	-23.30	Peak	VERTICAL
13070.00	39.92	39.37	44.37	11.42	46.34	68.20	-21.86	Peak	VERTICAL
<b>11a CH48</b>									
5675.00	41.93	35.57	43.40	8.01	42.11	68.20	-26.09	Peak	HORIZONTAL
7171.00	39.49	36.87	43.55	8.48	41.29	68.20	-26.91	Peak	HORIZONTAL
9007.00	39.19	37.50	44.10	10.37	42.96	68.20	-25.24	Peak	HORIZONTAL

									L
9959.00	40.79	38.16	44.39	10.87	45.43	68.20	-22.77	Peak	HORIZONTAL
12033.00	38.94	38.89	44.11	10.98	44.70	68.20	-23.50	Peak	HORIZONTAL
13410.00	39.70	39.71	44.45	11.76	46.72	68.20	-21.48	Peak	HORIZONTAL
5675.00	42.01	35.57	43.40	8.01	42.19	68.20	-26.01	Peak	VERTICAL
7511.00	39.55	37.00	43.65	8.79	41.69	68.20	-26.51	Peak	VERTICAL
10146.00	41.26	38.29	44.38	10.91	46.08	68.20	-22.12	Peak	VERTICAL
10979.00	39.08	38.79	44.25	11.06	44.68	68.20	-23.52	Peak	VERTICAL
12016.00	38.87	38.90	44.10	10.98	44.65	68.20	-23.55	Peak	VERTICAL
13121.00	40.05	39.42	44.38	11.47	46.56	68.20	-21.64	Peak	VERTICAL

Conclusion: Pass

Note:  $-27 \text{ dBm/MHz Limit} = 95.2 + \text{EIRP}[\text{dBm}] = 95.2 - 27 = 68.2 \text{ dB}\mu\text{V/m}$

For transmitters operating in the 5150MHz-5250MHz, 5725MHz-5850MHz band: all emissions outside of the 5.15-5.35 GHz band shall not exceed an EIRP of  $-27 \text{ dBm/MHz}$ .

Freq (MHz)	Read level (dB $\mu$ V)	Antenna Factor (dB/m)	PRM Factor (dB)	Cable Loss (dB)	Result Level (dB $\mu$ V/m)	Limit (dB $\mu$ V/m)	Margin (dB)	Detector type	Polarization
------------	-------------------------	-----------------------	-----------------	-----------------	-----------------------------	----------------------	-------------	---------------	--------------

#### 11a CH149

5199.00	42.37	35.20	43.68	7.71	41.60	68.20	-26.60	Peak	HORIZONTAL
7511.00	40.05	37.00	43.65	8.79	42.19	68.20	-26.01	Peak	HORIZONTAL
8854.00	40.47	37.44	44.06	10.20	44.05	68.20	-24.15	Peak	HORIZONTAL
10061.00	42.09	38.24	44.39	10.90	46.84	68.20	-21.36	Peak	HORIZONTAL
11795.00	39.52	38.78	44.13	10.99	45.16	68.20	-23.04	Peak	HORIZONTAL
13121.00	39.90	39.42	44.38	11.47	46.41	68.20	-21.79	Peak	HORIZONTAL
5675.00	41.74	35.57	43.40	8.01	41.92	68.20	-26.28	Peak	VERTICAL
8871.00	40.05	37.45	44.06	10.22	43.66	68.20	-24.54	Peak	VERTICAL
9891.00	40.28	38.09	44.37	10.83	44.83	68.20	-23.37	Peak	VERTICAL
11030.00	39.54	38.79	44.25	11.06	45.14	68.20	-23.06	Peak	VERTICAL
12288.00	39.00	38.84	44.17	11.08	44.75	68.20	-23.45	Peak	VERTICAL
13444.00	38.30	39.74	44.46	11.80	45.38	68.20	-22.82	Peak	VERTICAL

#### 11a CH157

5590.00	42.17	35.54	43.45	7.95	42.21	68.20	-25.99	Peak	HORIZONTAL
6270.00	39.66	35.70	43.28	8.24	40.32	68.20	-27.88	Peak	HORIZONTAL
8956.00	39.89	37.48	44.09	10.32	43.60	68.20	-24.60	Peak	HORIZONTAL
11404.00	39.52	38.64	44.19	11.02	44.99	68.20	-23.21	Peak	HORIZONTAL
12339.00	39.90	38.83	44.18	11.10	45.65	68.20	-22.55	Peak	HORIZONTAL
13359.00	38.97	39.66	44.44	11.71	45.90	68.20	-22.30	Peak	HORIZONTAL
4264.00	42.72	33.40	44.24	6.84	38.72	74.00	-35.28	Peak	VERTICAL
5675.00	42.69	35.57	43.40	8.01	42.87	74.00	-31.13	Peak	VERTICAL

7834.00	39.70	37.13	43.75	9.08	42.16	74.00	-31.84	Peak	VERTICAL
10979.00	39.51	38.79	44.25	11.06	45.11	74.00	-28.89	Peak	VERTICAL
12101.00	39.29	38.88	44.13	11.01	45.05	68.20	-23.15	Peak	VERTICAL
13410.00	38.46	39.71	44.45	11.76	45.48	68.20	-22.72	Peak	VERTICAL
<b>11a CH165</b>									
6151.00	40.24	35.70	43.25	8.23	40.92	68.20	-27.28	Peak	HORIZONTAL
8480.00	39.45	37.30	43.94	9.78	42.59	68.20	-25.61	Peak	HORIZONTAL
9874.00	40.75	38.07	44.36	10.82	45.28	68.20	-22.92	Peak	HORIZONTAL
10809.00	39.88	38.69	44.28	11.03	45.32	68.20	-22.88	Peak	HORIZONTAL
12050.00	39.81	38.89	44.11	10.99	45.58	68.20	-22.62	Peak	HORIZONTAL
13461.00	38.51	39.76	44.47	11.82	45.62	68.20	-22.58	Peak	HORIZONTAL
4706.00	43.85	34.53	43.98	7.29	41.69	68.20	-26.51	Peak	VERTICAL
6661.00	40.40	36.05	43.40	8.29	41.34	68.20	-26.86	Peak	VERTICAL
7936.00	40.21	37.17	43.78	9.17	42.77	68.20	-25.43	Peak	VERTICAL
10010.00	40.00	38.21	44.40	10.89	44.70	68.20	-23.50	Peak	VERTICAL
12016.00	38.88	38.90	44.10	10.98	44.66	68.20	-23.54	Peak	VERTICAL
13070.00	40.76	39.37	44.37	11.42	47.18	68.20	-21.02	Peak	VERTICAL
Conclusion: Pass									
Note: $-27 \text{ dBm/MHz Limit} = 95.2 + \text{EIRP}[\text{dBm}] = 95.2 - 27 = 68.2 \text{ dB}\mu\text{V/m}$ For transmitters operating in the 5150MHz-5250MHz, 5725MHz-5850MHz band: all emissions outside of the 5.15-5.35 GHz band shall not exceed an EIRP of -27 dBm/MHz. Result Level = Read Level + Antenna Factor + Cable loss - PRM Factor.									

Note: 1. Result Level = Read Level + Antenna Factor + Cable loss - PRM Factor.

2. If Peak Result complies with QP limit, QP Result is deemed to comply with AV limit.

3. Test setup: RBW: 1 MHz, VBW: 3 MHz, Sweep time: auto.

## 9. Band Edge Compliance

### 9.1. Block diagram of test setup

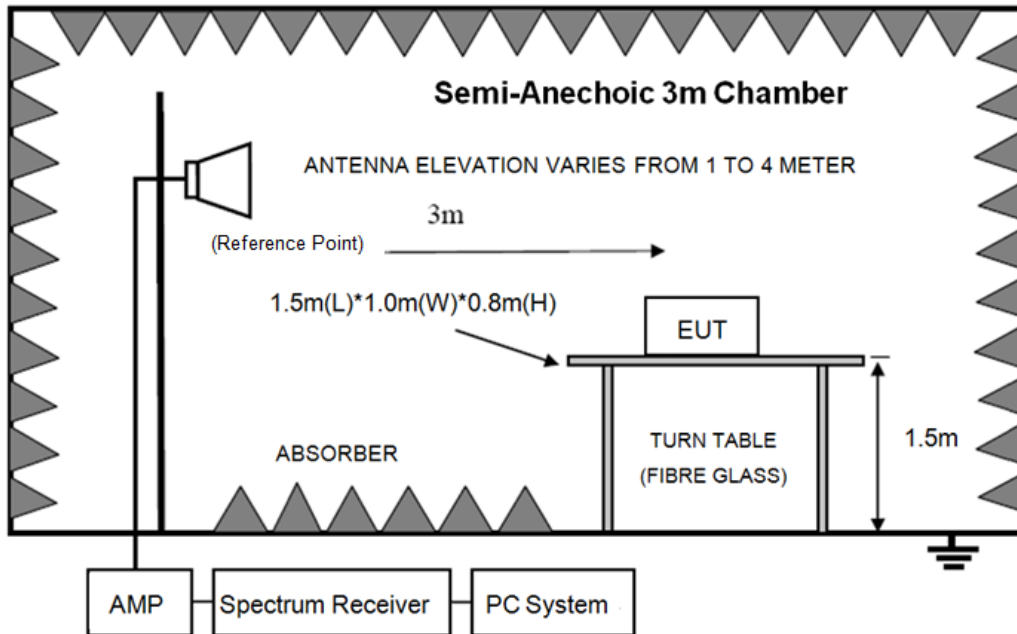

### 9.2. Limit

For transmitters operating in the 5.15-5.25 GHz band: All emissions outside of the 5.15-5.35 GHz band shall not exceed an EIRP of -27dBm/MHz

For transmitters operating in the 5.725-5.85 GHz band: All emissions within the frequency range from the band edge to 10 MHz above or below the band edge shall not exceed an EIRP of -17dBm/MHz; for frequencies 10MHz or greater above or below the band edge, emissions shall not exceed an EIRP of -27dBm/MHz

$$-17 \text{ dBm/MHz Limit} = 95.2 + \text{EIRP}[\text{dBm}] = 95.2 - 17 = 78.2 \text{ dB}\mu\text{V/m}$$

$$-27 \text{ dBm/MHz Limit} = 95.2 + \text{EIRP}[\text{dBm}] = 95.2 - 27 = 68.2 \text{ dB}\mu\text{V/m}$$

### 9.3. Test Procedure

Same with clause 8.3 except change investigated frequency range from 5.15-5.25 GHz, 5.725-5.85 GHz.

Remark: All restriction band have been tested, and only the worse case is shown in report.

#### 9.4. Test result

**PASS. (See below detailed test result)**

Note1: As specified in 15.407(b), emissions above 1000 MHz that are outside of the restricted bands are subject to a peak emission limit of -27 dBm/MHz (or -17 dBm/MHz as specified in 15.407(b)(4)). However, an out-of-band emission that complies with both the average and peak limits of 15.209 is not required to satisfy the -27 dBm/MHz or -17 dBm/MHz peak emission limit

Note2: 11a ANT 1, 11n, 11ac mode ANT 1 ANT 2 ANT 3 mode and MIMO mode all have been tested, only ANT 1 mode is the worst case and reported.

# TR-4-E-009 Radiated Emission Test Result

**Test Site** : DDT 3m Chamber 1# D:\2018 RE1# Report Data\Q18030203-1E GPON SFU ONT\RF.EM6  
**Test Date** : 2018-03-23 **Tested By** : Sunny  
**EUT** : GPON SFU ONT **Model Number** : 7285G  
**Power Supply** : AC 120V/60Hz **Test Mode** : Tx mode  
**Condition** : Temp:24.5°C,Humi:55%,  
 Press:100.1kPa **Antenna/Distance** : 2017 HF907/3m/HORIZONTAL  
**Memo** : 11a 5180MHz

Data: 27

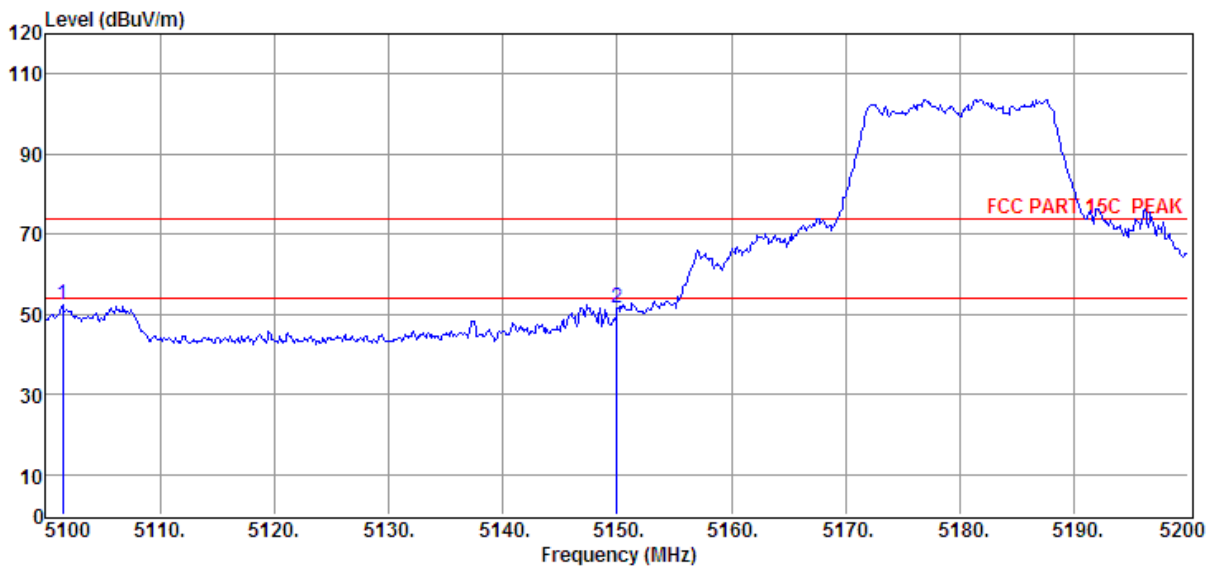

Item (Mark)	Freq. (MHz)	Read Level (dBμV)	Antenna Factor (dB/m)	PRM Factor dB	Cable Loss dB	Result Level (dBμV/m )	Limit Line (dBμV/ m)	Over Limit (dB)	Detector	Polarization
1	5101.50	53.32	35.10	43.74	7.64	52.32	74.00	-21.68	Peak	HORIZONTAL
2	5150.00	52.29	35.15	43.71	7.67	51.40	74.00	-22.60	Peak	HORIZONTAL

- Note: 1. Result Level = Read Level + Antenna Factor + Cable loss - PRM Factor.  
 2. If Peak Result complies with AV limit, AV Result is deemed to comply with AV limit.  
 3. Test setup: RBW: 1 MHz, VBW: 3 MHz, Sweep time: auto.

# TR-4-E-009 Radiated Emission Test Result

**Test Site** : DDT 3m Chamber 1# D:\2018 RE1# Report Data\Q18030203-1E GPON SFU ONT\RF.EM6  
**Test Date** : 2018-03-23 **Tested By** : Sunny  
**EUT** : GPON SFU ONT **Model Number** : 7285G  
**Power Supply** : AC 120V/60Hz **Test Mode** : Tx mode  
**Condition** : Temp:24.5°C,Humi:55%,  
 Press:100.1kPa **Antenna/Distance** : 2017 HF907/3m/VERTICAL  
**Memo** : 11a 5180MHz

Data: 28

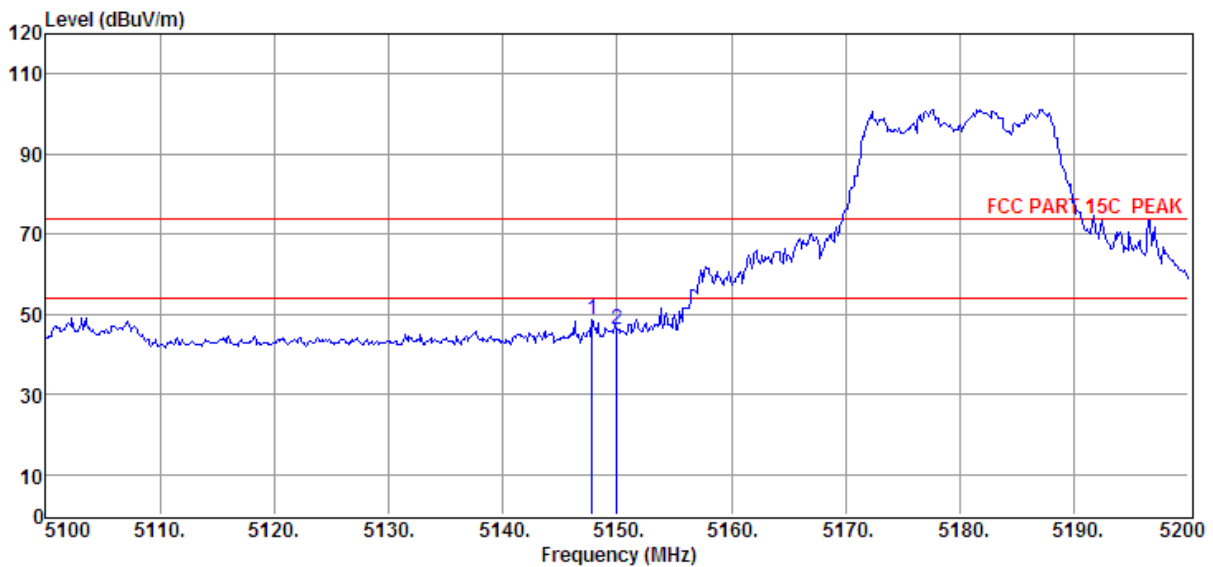

Item (Mark)	Freq. (MHz)	Read Level (dBμV)	Antenna Factor (dB/m)	PRM Factor dB	Cable Loss dB	Result Level (dBμV/m)	Limit Line (dBμV/m)	Over Limit (dB)	Detector	Polarization
1	5147.80	49.62	35.15	43.71	7.67	48.73	74.00	-25.27	Peak	VERTICAL
2	5150.00	46.91	35.15	43.71	7.67	46.02	74.00	-27.98	Peak	VERTICAL

- Note: 1. Result Level = Read Level + Antenna Factor + Cable loss - PRM Factor.  
 2. If Peak Result complies with AV limit, AV Result is deemed to comply with AV limit.  
 3. Test setup: RBW: 1 MHz, VBW: 3 MHz, Sweep time: auto.



# TR-4-E-009 Radiated Emission Test Result

<b>Test Site</b>	: DDT 3m Chamber 1#	D:\2018 RE1# Report Data\Q18030203-1E GPON SFU ONT\RF.EM6
<b>Test Date</b>	: 2018-03-23	<b>Tested By</b> : Sunny
<b>EUT</b>	: GPON SFU ONT	<b>Model Number</b> : 7285G
<b>Power Supply</b>	: AC 120V/60Hz	<b>Test Mode</b> : Tx mode
<b>Condition</b>	: Temp:24.5°C,Humi:55%, Press:100.1kPa	<b>Antenna/Distance</b> : 2017 HF907/3m/VERTICAL
<b>Memo</b>	: 11a 5240MHz	

Data: 41

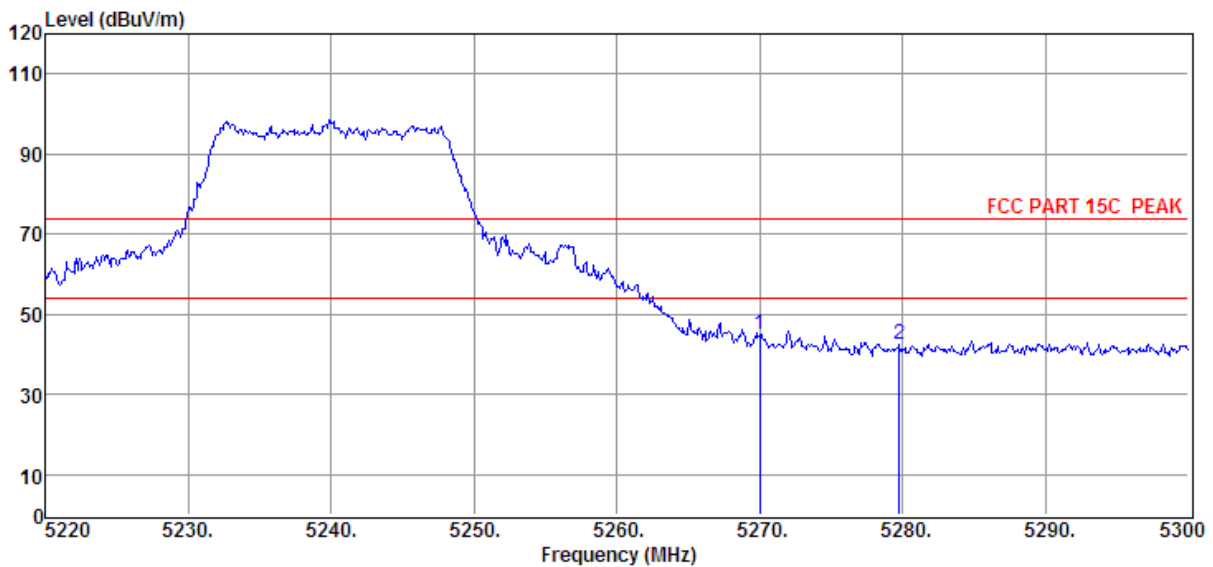

Item (Mark)	Freq. (MHz)	Read Level (dBμV)	Antenna Factor (dB/m)	PRM Factor dB	Cable Loss dB	Result Level (dBμV/m)	Limit Line (dBμV/m)	Over Limit (dB)	Detector	Polarization
1	5270.00	45.75	35.27	43.64	7.75	45.13	74.00	-28.87	Peak	VERTICAL
2	5279.76	43.03	35.28	43.63	7.76	42.44	74.00	-31.56	Peak	VERTICAL

Note: 1. Result Level = Read Level + Antenna Factor + Cable loss - PRM Factor.  
 2. If Peak Result complies with AV limit, AV Result is deemed to comply with AV limit.  
 3. Test setup: RBW: 1 MHz, VBW: 3 MHz, Sweep time: auto.

# TR-4-E-009 Radiated Emission Test Result

**Test Site** : DDT 3m Chamber 1# D:\2018 RE1# Report Data\Q18030203-1E GPON SFU ONT\RF.EM6  
**Test Date** : 2018-03-23 **Tested By** : Sunny  
**EUT** : GPON SFU ONT **Model Number** : 7285G  
**Power Supply** : AC 120V/60Hz **Test Mode** : Tx mode  
**Condition** : Temp:24.5°C,Humi:55%,  
 Press:100.1kPa **Antenna/Distance** : 2017 HF907/3m/HORIZONTAL  
**Memo** : 11a 5240MHz

Data: 42

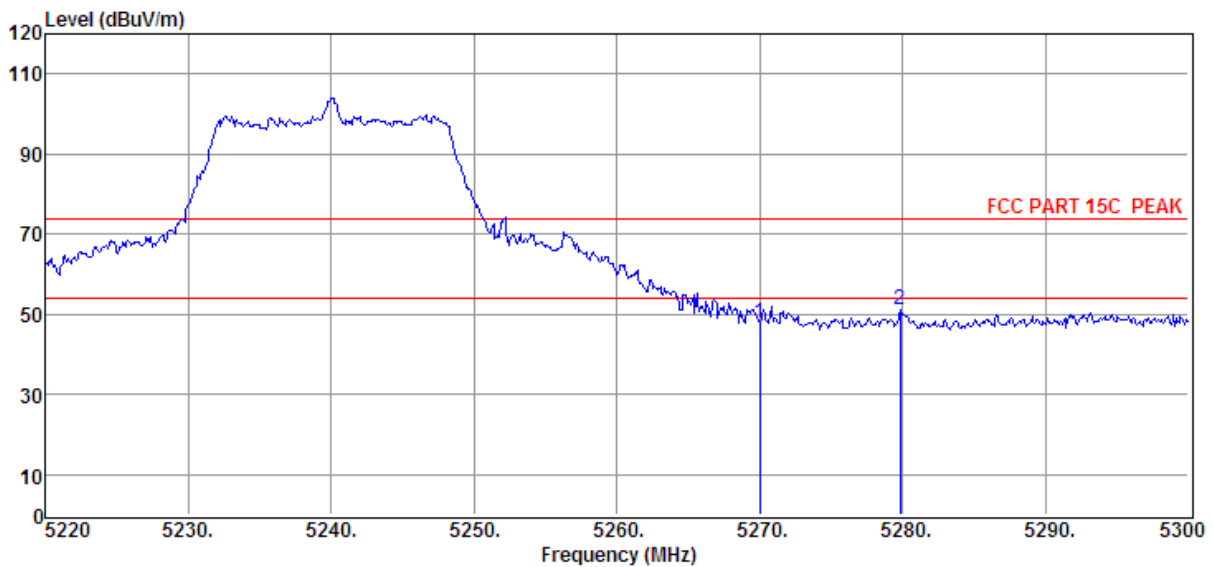

Item (Mark)	Freq. (MHz)	Read Level (dBμV)	Antenna Factor (dB/m)	PRM Factor dB	Cable Loss dB	Result Level (dBμV/m )	Limit Line (dBμV/ m)	Over Limit (dB)	Detector	Polarization
1	5270.00	48.39	35.27	43.64	7.75	47.77	74.00	-26.23	Peak	HORIZONTAL
2	5279.84	51.75	35.28	43.63	7.76	51.16	74.00	-22.84	Peak	HORIZONTAL

- Note: 1. Result Level = Read Level + Antenna Factor + Cable loss - PRM Factor.  
 2. If Peak Result complies with AV limit, AV Result is deemed to comply with AV limit.  
 3. Test setup: RBW: 1 MHz, VBW: 3 MHz, Sweep time: auto.

# TR-4-E-009 Radiated Emission Test Result

<b>Test Site</b>	: DDT 3m Chamber 1#	D:\2018 RE1# Report Data\Q18030203-1E GPON SFU ONT\RF.EM6
<b>Test Date</b>	: 2018-03-23	<b>Tested By</b> : Sunny
<b>EUT</b>	: GPON SFU ONT	<b>Model Number</b> : 7285G
<b>Power Supply</b>	: AC 120V/60Hz	<b>Test Mode</b> : Tx mode
<b>Condition</b>	: Temp:24.5°C,Humi:55%, Press:100.1kPa	<b>Antenna/Distance</b> : 2017 HF907/3m/HORIZONTAL
<b>Memo</b>	: 11a 5745MHz	

Data: 43

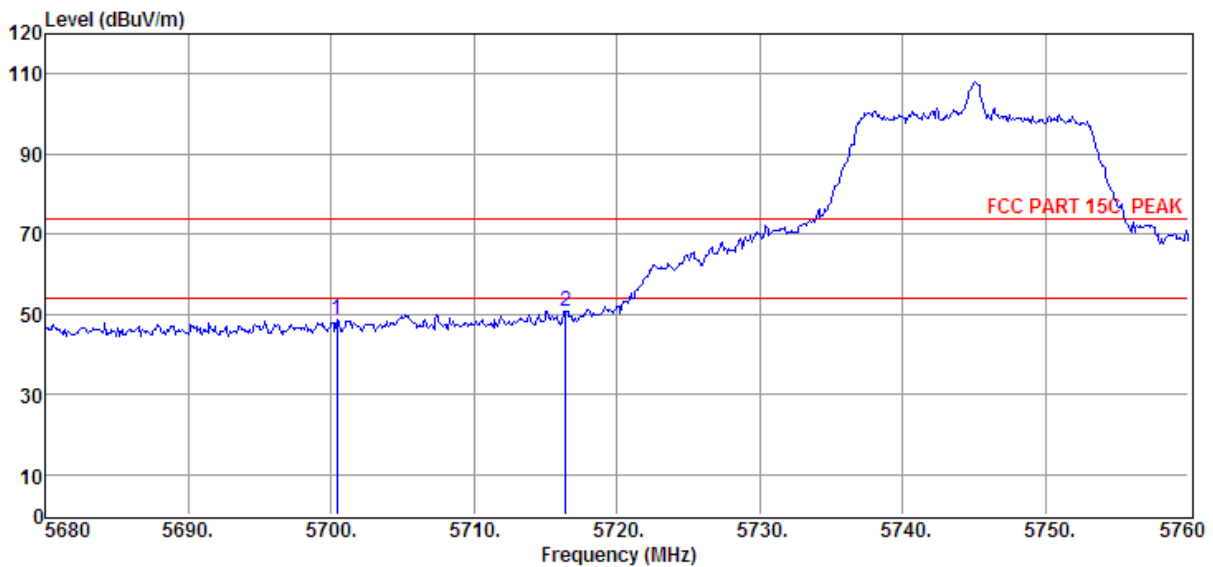

Item (Mark)	Freq. (MHz)	Read Level (dBμV)	Antenna Factor (dB/m)	PRM Factor dB	Cable Loss dB	Result Level (dBμV/m)	Limit Line (dBμV/m)	Over Limit (dB)	Detector	Polarization
1	5700.40	48.27	35.58	43.38	8.02	48.49	74.00	-25.51	Peak	HORIZONTAL
2	5716.40	50.45	35.59	43.37	8.03	50.70	74.00	-23.30	Peak	HORIZONTAL

- Note: 1. Result Level = Read Level + Antenna Factor + Cable loss - PRM Factor.  
 2. If Peak Result complies with AV limit, AV Result is deemed to comply with AV limit.  
 3. Test setup: RBW: 1 MHz, VBW: 3 MHz, Sweep time: auto.

# TR-4-E-009 Radiated Emission Test Result

<b>Test Site</b>	: DDT 3m Chamber 1#	D:\2018 RE1# Report Data\Q18030203-1E GPON SFU ONT\RF.EM6
<b>Test Date</b>	: 2018-03-23	<b>Tested By</b> : Sunny
<b>EUT</b>	: GPON SFU ONT	<b>Model Number</b> : 7285G
<b>Power Supply</b>	: AC 120V/60Hz	<b>Test Mode</b> : Tx mode
<b>Condition</b>	: Temp:24.5°C,Humi:55%, Press:100.1kPa	<b>Antenna/Distance</b> : 2017 HF907/3m/VERTICAL
<b>Memo</b>	: 11a 5745MHz	

Data: 44

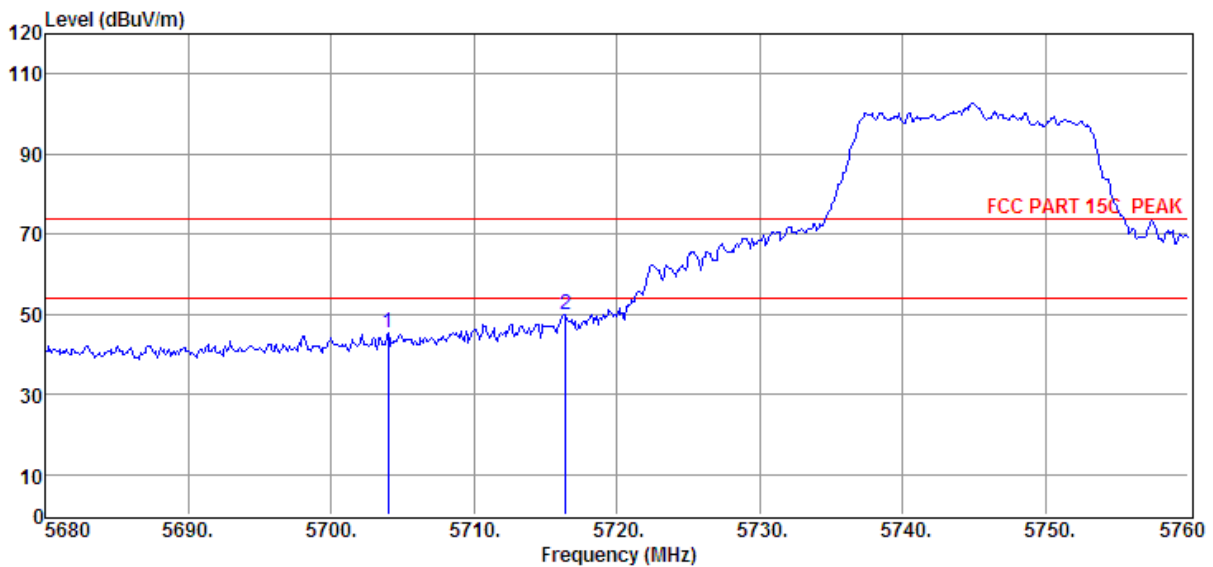

Item (Mark)	Freq. (MHz)	Read Level (dBμV)	Antenna Factor (dB/m)	PRM Factor dB	Cable Loss dB	Result Level (dBμV/m)	Limit Line (dBμV/m)	Over Limit (dB)	Detector	Polarization
1	5704.00	45.13	35.58	43.38	8.02	45.35	74.00	-28.65	Peak	VERTICAL
2	5716.40	49.58	35.59	43.37	8.03	49.83	74.00	-24.17	Peak	VERTICAL

- Note: 1. Result Level = Read Level + Antenna Factor + Cable loss - PRM Factor.  
 2. If Peak Result complies with AV limit, AV Result is deemed to comply with AV limit.  
 3. Test setup: RBW: 1 MHz, VBW: 3 MHz, Sweep time: auto.

# TR-4-E-009 Radiated Emission Test Result

<b>Test Site</b>	: DDT 3m Chamber 1#	D:\2018 RE1# Report Data\Q18030203-1E GPON SFU ONT\RF.EM6
<b>Test Date</b>	: 2018-03-23	<b>Tested By</b> : Sunny
<b>EUT</b>	: GPON SFU ONT	<b>Model Number</b> : 7285G
<b>Power Supply</b>	: AC 120V/60Hz	<b>Test Mode</b> : Tx mode
<b>Condition</b>	: Temp:24.5°C,Humi:55%, Press:100.1kPa	<b>Antenna/Distance</b> : 2017 HF907/3m/VERTICAL
<b>Memo</b>	: 11a 5825MHz	

Data: 45

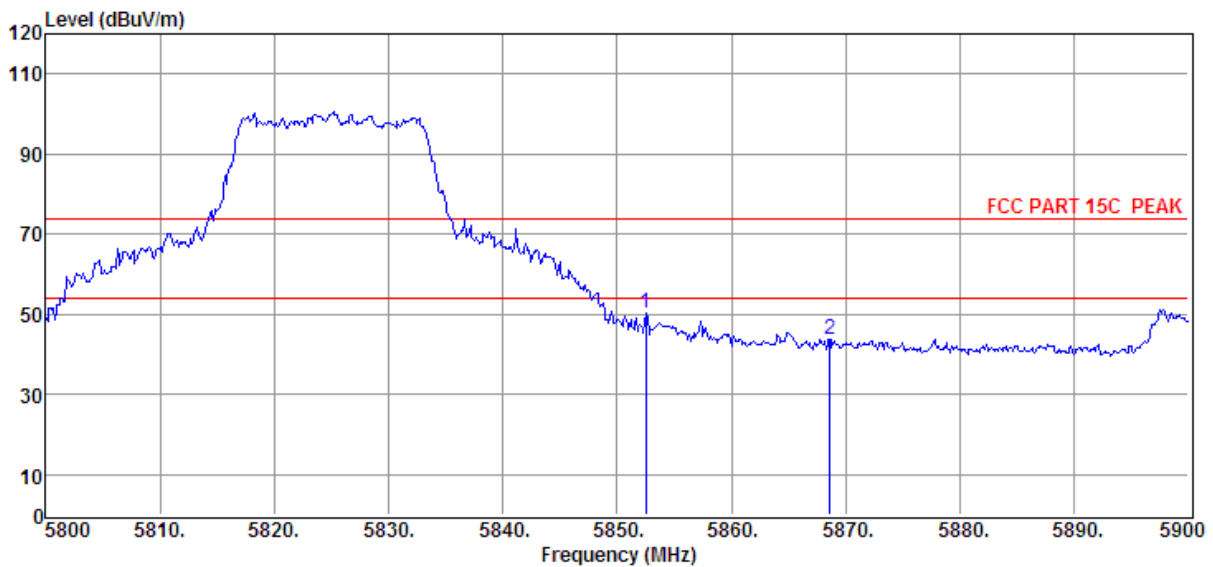

Item (Mark)	Freq. (MHz)	Read Level (dBμV)	Antenna Factor (dB/m)	PRM Factor dB	Cable Loss dB	Result Level (dBμV/m )	Limit Line (dBμV/ m)	Over Limit (dB)	Detector	Polarization
1	5852.50	50.04	35.64	43.29	8.12	50.51	74.00	-23.49	Peak	VERTICAL
2	5868.60	43.23	35.65	43.28	8.13	43.73	74.00	-30.27	Peak	VERTICAL

Note: 1. Result Level = Read Level + Antenna Factor + Cable loss - PRM Factor.  
 2. If Peak Result complies with AV limit, AV Result is deemed to comply with AV limit.  
 3. Test setup: RBW: 1 MHz, VBW: 3 MHz, Sweep time: auto.

# TR-4-E-009 Radiated Emission Test Result

**Test Site** : DDT 3m Chamber 1# D:\2018 RE1# Report Data\Q18030203-1E GPON SFU ONT\RF.EM6  
**Test Date** : 2018-03-23 **Tested By** : Sunny  
**EUT** : GPON SFU ONT **Model Number** : 7285G  
**Power Supply** : AC 120V/60Hz **Test Mode** : Tx mode  
**Condition** : Temp:24.5°C,Humi:55%,  
 Press:100.1kPa **Antenna/Distance** : 2017 HF907/3m/HORIZONTAL  
**Memo** : 11a 5825MHz

Data: 46

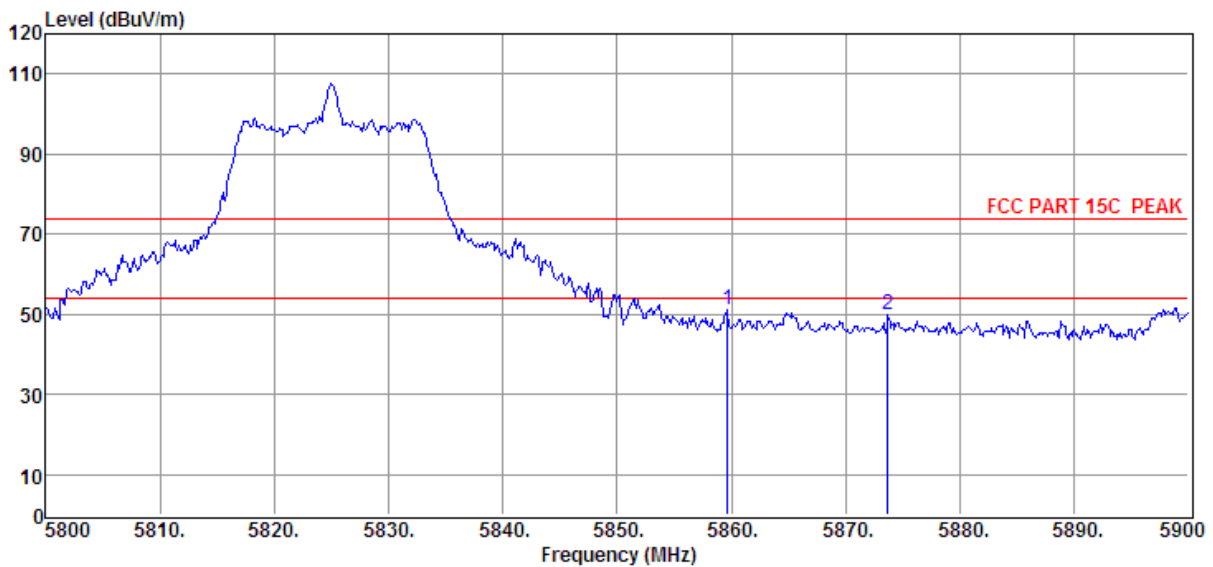

Item (Mark)	Freq. (MHz)	Read Level (dBμV)	Antenna Factor (dB/m)	PRM Factor dB	Cable Loss dB	Result Level (dBμV/m)	Limit Line (dBμV/m)	Over Limit (dB)	Detector	Polarization
1	5859.70	50.71	35.64	43.28	8.12	51.19	74.00	-22.81	Peak	HORIZONTAL
2	5873.70	49.20	35.65	43.28	8.13	49.70	74.00	-24.30	Peak	HORIZONTAL

- Note: 1. Result Level = Read Level + Antenna Factor + Cable loss - PRM Factor.  
 2. If Peak Result complies with AV limit, AV Result is deemed to comply with AV limit.  
 3. Test setup: RBW: 1 MHz, VBW: 3 MHz, Sweep time: auto.

# TR-4-E-009 Radiated Emission Test Result

<b>Test Site</b>	: DDT 3m Chamber 1#	D:\2018 RE1# Report Data\Q18030203-1E GPON SFU ONT\RF.EM6
<b>Test Date</b>	: 2018-03-23	<b>Tested By</b> : Sunny
<b>EUT</b>	: GPON SFU ONT	<b>Model Number</b> : 7285G
<b>Power Supply</b>	: AC 120V/60Hz	<b>Test Mode</b> : Tx mode
<b>Condition</b>	: Temp:24.5°C,Humi:55%, Press:100.1kPa	<b>Antenna/Distance</b> : 2017 HF907/3m/HORIZONTAL
<b>Memo</b>	: 11n20 5180MHz	

Data: 47

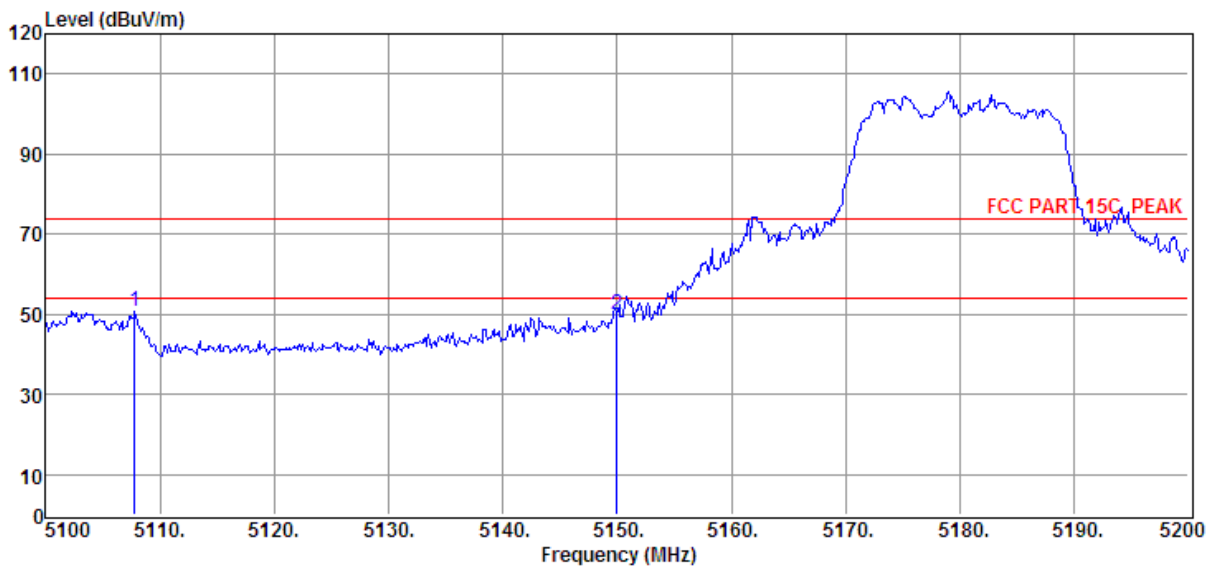

Item (Mark)	Freq. (MHz)	Read Level (dBμV)	Antenna Factor (dB/m)	PRM Factor dB	Cable Loss dB	Result Level (dBμV/m)	Limit Line (dBμV/m)	Over Limit (dB)	Detector	Polarization
1	5107.80	51.88	35.11	43.74	7.65	50.90	74.00	-23.10	Peak	HORIZONTAL
2	5150.00	50.78	35.15	43.71	7.67	49.89	74.00	-24.11	Peak	HORIZONTAL

- Note: 1. Result Level = Read Level + Antenna Factor + Cable loss - PRM Factor.  
 2. If Peak Result complies with AV limit, AV Result is deemed to comply with AV limit.  
 3. Test setup: RBW: 1 MHz, VBW: 3 MHz, Sweep time: auto.

# TR-4-E-009 Radiated Emission Test Result

<b>Test Site</b>	: DDT 3m Chamber 1#	D:\2018 RE1# Report Data\Q18030203-1E GPON SFU ONT\RF.EM6
<b>Test Date</b>	: 2018-03-23	<b>Tested By</b> : Sunny
<b>EUT</b>	: GPON SFU ONT	<b>Model Number</b> : 7285G
<b>Power Supply</b>	: AC 120V/60Hz	<b>Test Mode</b> : Tx mode
<b>Condition</b>	: Temp:24.5°C,Humi:55%, Press:100.1kPa	<b>Antenna/Distance</b> : 2017 HF907/3m/VERTICAL
<b>Memo</b>	: 11n20 5180MHz	

Data: 48

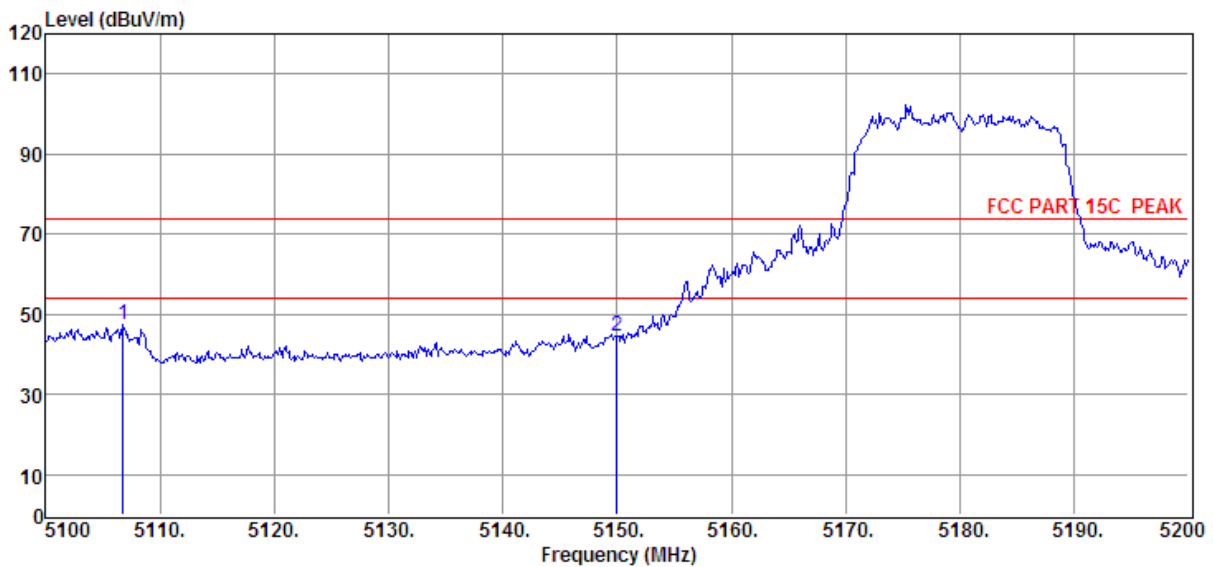

Item (Mark)	Freq. (MHz)	Read Level (dBμV)	Antenna Factor (dB/m)	PRM Factor dB	Cable Loss dB	Result Level (dBμV/m )	Limit Line (dBμV/m)	Over Limit (dB)	Detector	Polarization
1	5106.80	48.60	35.11	43.74	7.65	47.62	74.00	-26.38	Peak	VERTICAL
2	5150.00	45.49	35.15	43.71	7.67	44.60	74.00	-29.40	Peak	VERTICAL

- Note: 1. Result Level = Read Level + Antenna Factor + Cable loss - PRM Factor.  
 2. If Peak Result complies with AV limit, AV Result is deemed to comply with AV limit.  
 3. Test setup: RBW: 1 MHz, VBW: 3 MHz, Sweep time: auto.



# TR-4-E-009 Radiated Emission Test Result

**Test Site** : DDT 3m Chamber 1# D:\2018 RE1# Report Data\Q18030203-1E GPON SFU ONT\RF.EM6  
**Test Date** : 2018-03-23 **Tested By** : Sunny  
**EUT** : GPON SFU ONT **Model Number** : 7285G  
**Power Supply** : AC 120V/60Hz **Test Mode** : Tx mode  
**Condition** : Temp:24.5°C,Humi:55%,  
 Press:100.1kPa **Antenna/Distance** : 2017 HF907/3m/VERTICAL  
**Memo** : 11n40 5190MHz

Data: 69

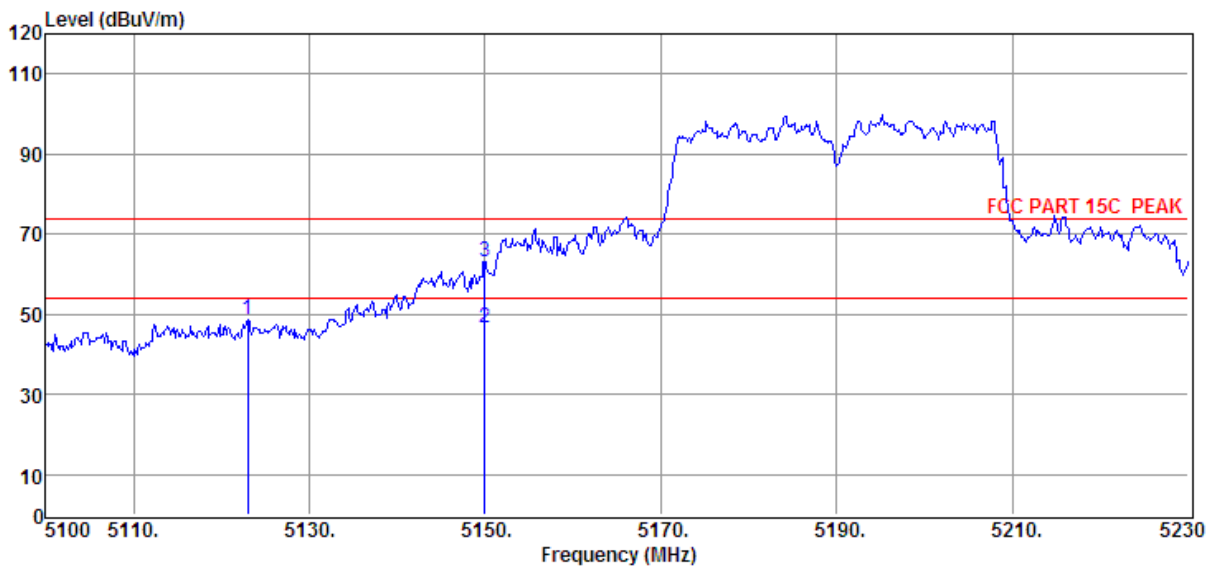

Item (Mark)	Freq. (MHz)	Read Level (dBμV)	Antenna Factor (dB/m)	PRM Factor dB	Cable Loss dB	Result Level (dBμV/m )	Limit Line (dBμV/ m)	Over Limit (dB)	Detector	Polarization
1	5123.01	49.60	35.12	43.73	7.66	48.65	74.00	-25.35	Peak	VERTICAL
2	5150.00	47.45	35.15	43.71	7.67	46.56	54.00	-7.44	Average	VERTICAL
3	5150.00	63.87	35.15	43.71	7.67	62.98	74.00	-11.02	Peak	VERTICAL

- Note: 1. Result Level = Read Level + Antenna Factor + Cable loss - PRM Factor.  
 2. If Peak Result complies with AV limit, AV Result is deemed to comply with AV limit.  
 3. Test setup: RBW: 1 MHz, VBW: 3 MHz, Sweep time: auto.  
 4. Test setup: RBW: 1 MHz, VBW: 10 Hz, Sweep time: auto for average measure.

# TR-4-E-009 Radiated Emission Test Result

**Test Site** : DDT 3m Chamber 1# D:\2018 RE1# Report Data\Q18030203-1E GPON SFU ONT\RF.EM6  
**Test Date** : 2018-03-23 **Tested By** : Sunny  
**EUT** : GPON SFU ONT **Model Number** : 7285G  
**Power Supply** : AC 120V/60Hz **Test Mode** : Tx mode  
**Condition** : Temp:24.5°C,Humi:55%,  
 Press:100.1kPa **Antenna/Distance** : 2017 HF907/3m/HORIZONTAL  
**Memo** : 11n40 5190MHz

Data: 70

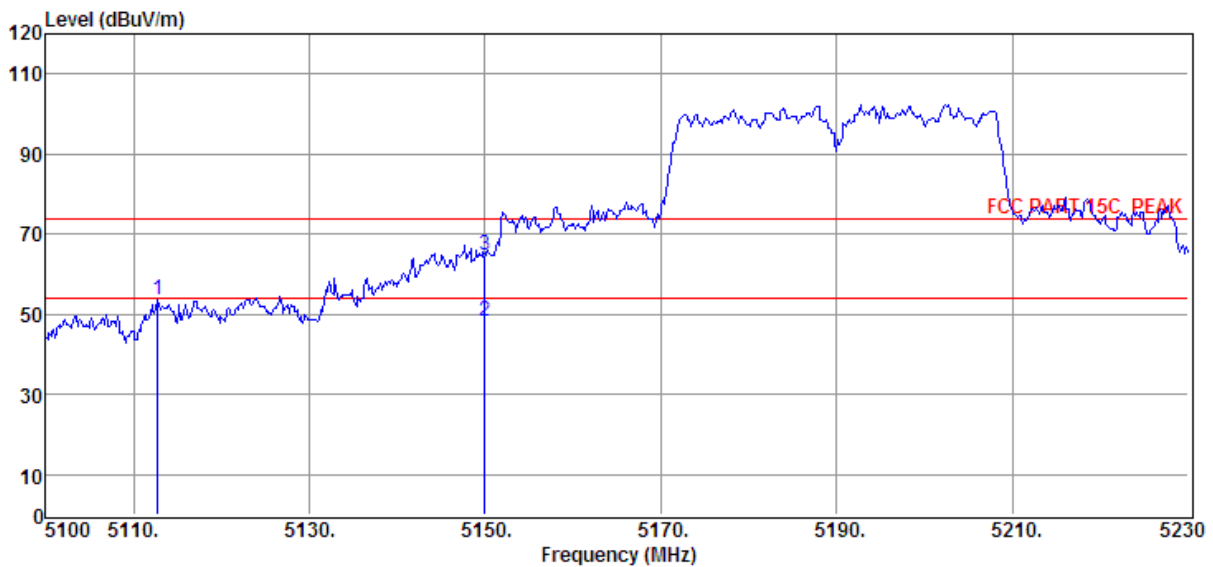

Item (Mark)	Freq. (MHz)	Read Level (dBμV)	Antenna Factor (dB/m)	PRM Factor dB	Cable Loss dB	Result Level (dBμV/m )	Limit Line (dBμV/ m)	Over Limit (dB)	Detector	Polarization
1	5112.74	54.55	35.11	43.73	7.65	53.58	74.00	-20.42	Peak	HORIZONTAL
2	5150.00	49.33	35.15	43.71	7.67	48.44	54.00	-5.56	Average	HORIZONTAL
3	5150.00	65.65	35.15	43.71	7.67	64.76	74.00	-9.24	Peak	HORIZONTAL

- Note: 1. Result Level = Read Level + Antenna Factor + Cable loss - PRM Factor.  
 2. If Peak Result complies with AV limit, AV Result is deemed to comply with AV limit.  
 3. Test setup: RBW: 1 MHz, VBW: 3 MHz, Sweep time: auto.  
 4. Test setup: RBW: 1 MHz, VBW: 10 Hz, Sweep time: auto for average measure.

# TR-4-E-009 Radiated Emission Test Result

<b>Test Site</b>	: DDT 3m Chamber 1#	D:\2018 RE1# Report Data\Q18030203-1E GPON SFU ONT\RF.EM6
<b>Test Date</b>	: 2018-03-23	<b>Tested By</b> : Sunny
<b>EUT</b>	: GPON SFU ONT	<b>Model Number</b> : 7285G
<b>Power Supply</b>	: AC 120V/60Hz	<b>Test Mode</b> : Tx mode
<b>Condition</b>	: Temp:24.5°C,Humi:55%, Press:100.1kPa	<b>Antenna/Distance</b> : 2017 HF907/3m/HORIZONTAL
<b>Memo</b>	: 11ac20 5180MHz	

Data: 71

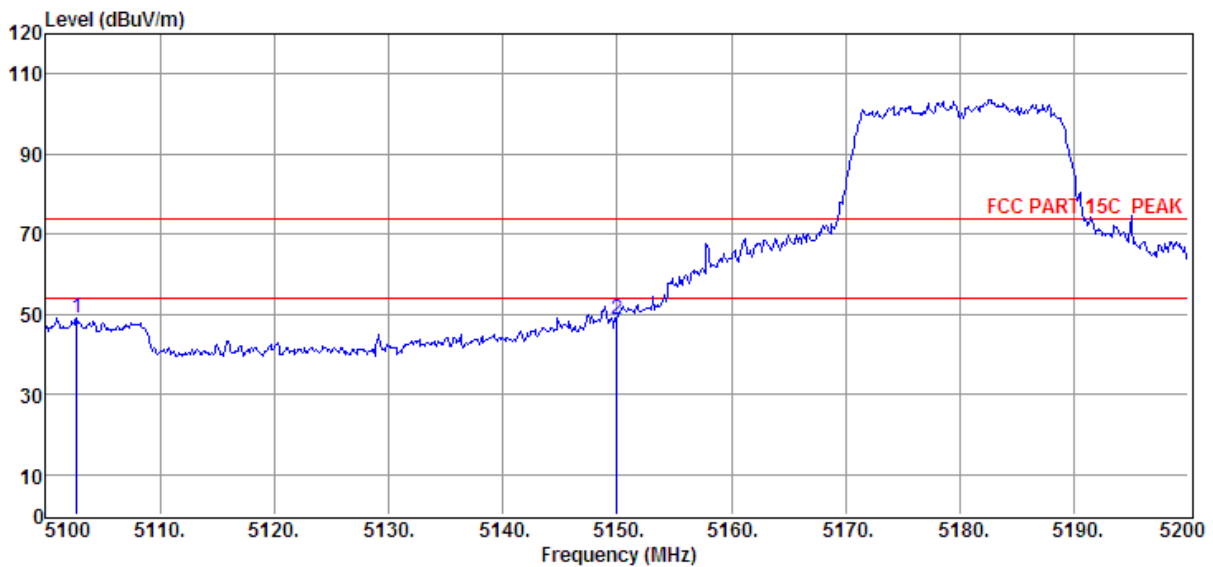

Item (Mark)	Freq. (MHz)	Read Level (dBμV)	Antenna Factor (dB/m)	PRM Factor dB	Cable Loss dB	Result Level (dBμV/m)	Limit Line (dBμV/m)	Over Limit (dB)	Detector	Polarization
1	5102.70	50.15	35.10	43.74	7.64	49.15	74.00	-24.85	Peak	HORIZONTAL
2	5150.00	49.63	35.15	43.71	7.67	48.74	74.00	-25.26	Peak	HORIZONTAL

- Note: 1. Result Level = Read Level + Antenna Factor + Cable loss - PRM Factor.  
 2. If Peak Result complies with AV limit, AV Result is deemed to comply with AV limit.  
 3. Test setup: RBW: 1 MHz, VBW: 3 MHz, Sweep time: auto.

# TR-4-E-009 Radiated Emission Test Result

**Test Site** : DDT 3m Chamber 1# D:\2018 RE1# Report Data\Q18030203-1E GPON SFU ONT\RF.EM6  
**Test Date** : 2018-03-23 **Tested By** : Sunny  
**EUT** : GPON SFU ONT **Model Number** : 7285G  
**Power Supply** : AC 120V/60Hz **Test Mode** : Tx mode  
**Condition** : Temp:24.5°C,Humi:55%,  
 Press:100.1kPa **Antenna/Distance** : 2017 HF907/3m/VERTICAL  
**Memo** : 11ac20 5180MHz

Data: 72

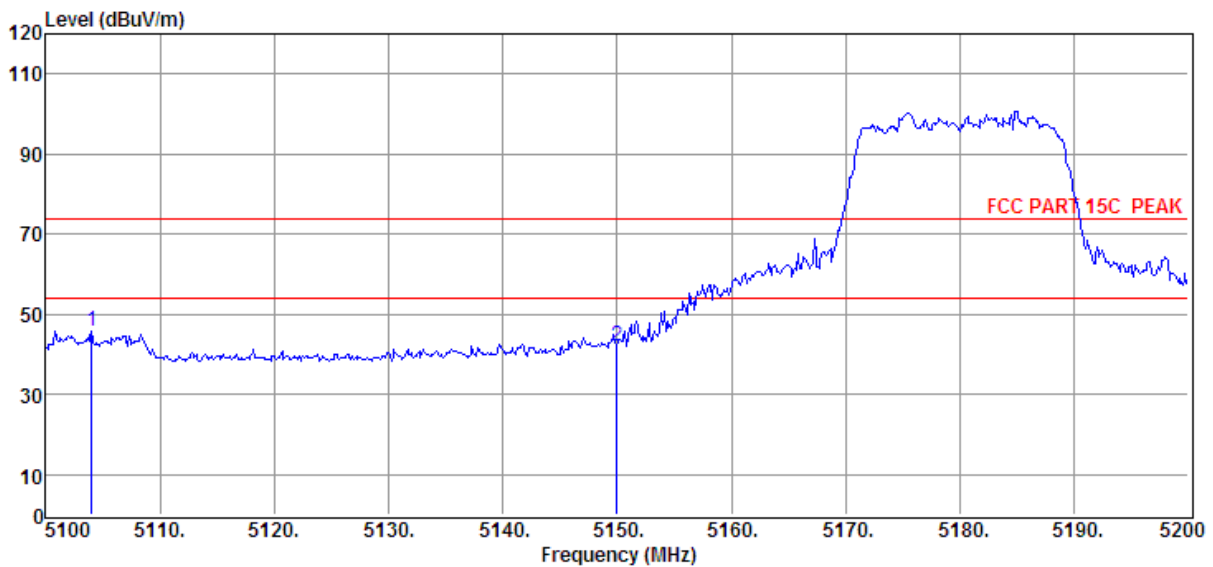

Item (Mark)	Freq. (MHz)	Read Level (dBµV)	Antenna Factor (dB/m)	PRM Factor dB	Cable Loss dB	Result Level (dBµV/m)	Limit Line (dBµV/m)	Over Limit (dB)	Detector	Polarization
1	5104.00	46.77	35.10	43.74	7.65	45.78	74.00	-28.22	Peak	VERTICAL
2	5150.00	42.83	35.15	43.71	7.67	41.94	74.00	-32.06	Peak	VERTICAL

- Note: 1. Result Level = Read Level + Antenna Factor + Cable loss - PRM Factor.  
 2. If Peak Result complies with AV limit, AV Result is deemed to comply with AV limit.  
 3. Test setup: RBW: 1 MHz, VBW: 3 MHz, Sweep time: auto.

# TR-4-E-009 Radiated Emission Test Result

**Test Site** : DDT 3m Chamber 1#  
**Test Date** : 2018-03-23  
**EUT** : GPON SFU ONT  
**Power Supply** : AC 120V/60Hz  
**Condition** : Temp:24.5°C,Humi:55%, Press:100.1kPa  
**Memo** : 11ac40 5190MHz  
**D:\2018 RE1# Report Data\Q18030203-1E GPON SFU ONT\RF.EM6**  
**Tested By** : Sunny  
**Model Number** : 7285G  
**Test Mode** : Tx mode  
**Antenna/Distance** : 2017 HF907/3m/VERTICAL

Data: 93

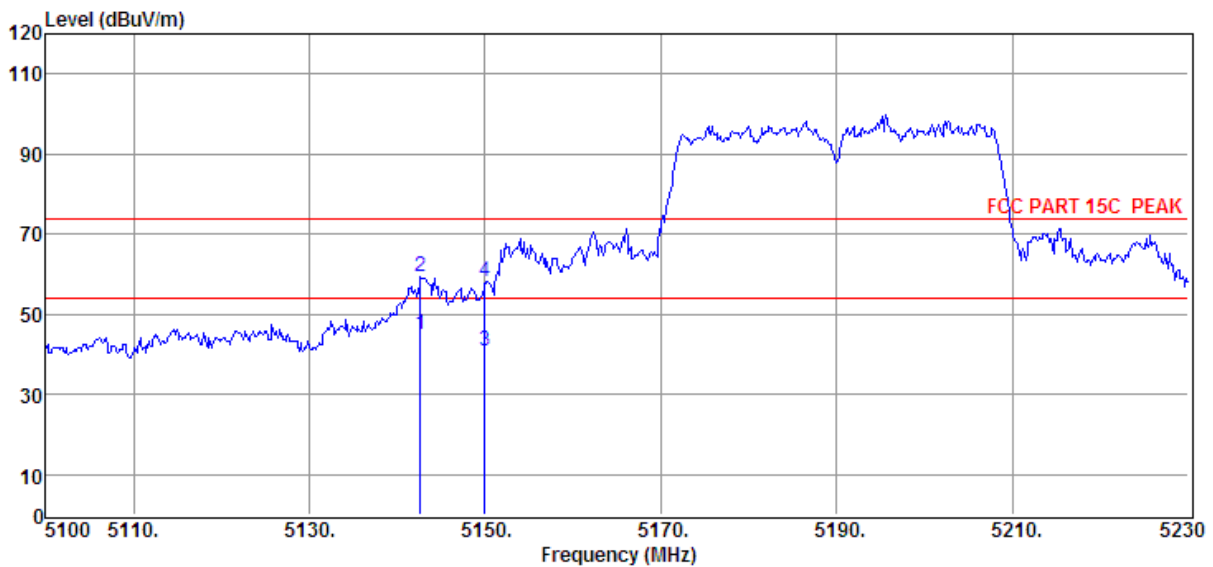

Item (Mark)	Freq. (MHz)	Read Level (dBµV)	Antenna Factor (dB/m)	PRM Factor dB	Cable Loss dB	Result Level (dBµV/m )	Limit Line (dBµV/ m)	Over Limit (dB)	Detector	Polarization
1	5142.64	45.65	35.14	43.71	7.67	44.75	54.00	-9.25	Average	VERTICAL
2	5142.64	60.14	35.14	43.71	7.67	59.24	74.00	-14.76	Peak	VERTICAL
3	5150.00	41.79	35.15	43.71	7.67	40.90	54.00	-13.10	Average	VERTICAL
4	5150.00	58.86	35.15	43.71	7.67	57.97	74.00	-16.03	Peak	VERTICAL

- Note: 1. Result Level = Read Level + Antenna Factor + Cable loss - PRM Factor.  
 2. If Peak Result complies with AV limit, AV Result is deemed to comply with AV limit.  
 3. Test setup: RBW: 1 MHz, VBW: 3 MHz, Sweep time: auto.  
 4. Test setup: RBW: 1 MHz, VBW: 10 Hz, Sweep time: auto for average measure.

# TR-4-E-009 Radiated Emission Test Result

**Test Site** : DDT 3m Chamber 1# D:\2018 RE1# Report Data\Q18030203-1E GPON SFU ONT\RF.EM6  
**Test Date** : 2018-03-23 **Tested By** : Sunny  
**EUT** : GPON SFU ONT **Model Number** : 7285G  
**Power Supply** : AC 120V/60Hz **Test Mode** : Tx mode  
**Condition** : Temp:24.5°C,Humi:55%,  
 Press:100.1kPa **Antenna/Distance** : 2017 HF907/3m/HORIZONTAL  
**Memo** : 11ac40 5190MHz

Data: 94

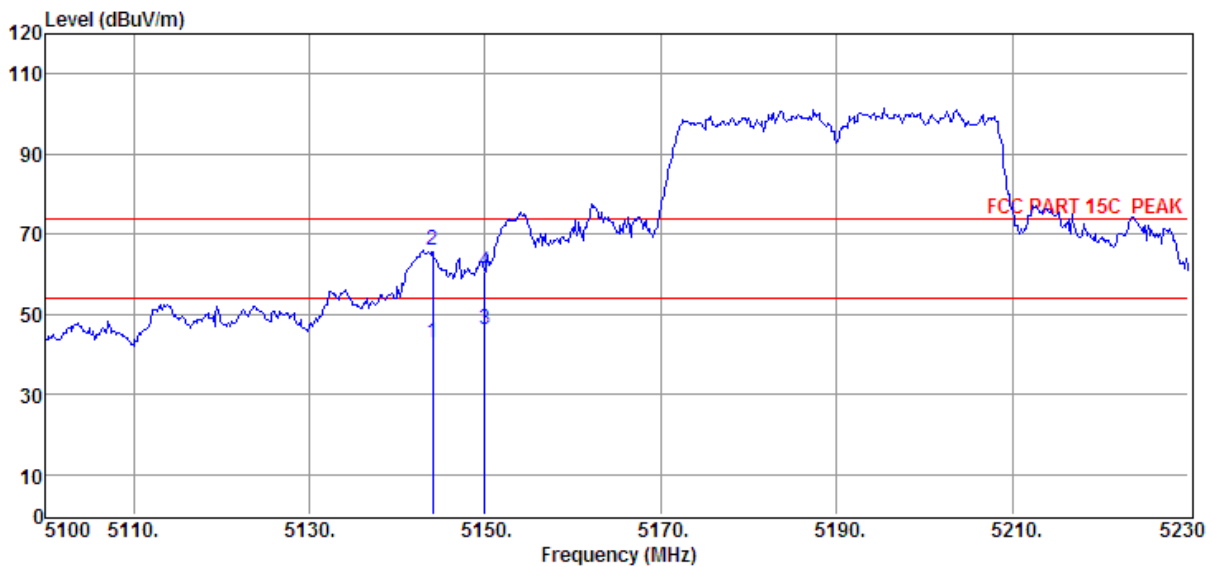

Item (Mark)	Freq. (MHz)	Read Level (dBμV)	Antenna Factor (dB/m)	PRM Factor dB	Cable Loss dB	Result Level (dBμV/m)	Limit Line (dBμV/m)	Over Limit (dB)	Detector	Polarization
1	5144.02	43.86	35.14	43.71	7.67	42.96	54.00	-11.04	Average	HORIZONTAL
2	5144.02	66.80	35.14	43.71	7.67	65.90	74.00	-8.10	Peak	HORIZONTAL
3	5150.00	47.17	35.15	43.71	7.67	46.28	54.00	-7.72	Average	HORIZONTAL
4	5150.00	61.63	35.15	43.71	7.67	60.74	74.00	-13.26	Peak	HORIZONTAL

- Note: 1. Result Level = Read Level + Antenna Factor + Cable loss - PRM Factor.  
 2. If Peak Result complies with AV limit, AV Result is deemed to comply with AV limit.  
 3. Test setup: RBW: 1 MHz, VBW: 3 MHz, Sweep time: auto.  
 4. Test setup: RBW: 1 MHz, VBW: 10 Hz, Sweep time: auto for average measure.

# TR-4-E-009 Radiated Emission Test Result

<b>Test Site</b>	: DDT 3m Chamber 1#	<b>Tested By</b>	: Sunny
<b>Test Date</b>	: 2018-03-29	<b>Model Number</b>	: 7285G
<b>EUT</b>	: GPON SFU ONT	<b>Test Mode</b>	: Tx mode
<b>Power Supply</b>	: AC 120V/60Hz	<b>Antenna/Distance</b>	: 2017 HF907/3m/VERTICAL
<b>Condition</b>	: Temp:24.5°C,Humi:55%, Press:100.1kPa		
<b>Memo</b>	: 11ac80 5210MHz		

Data: 95

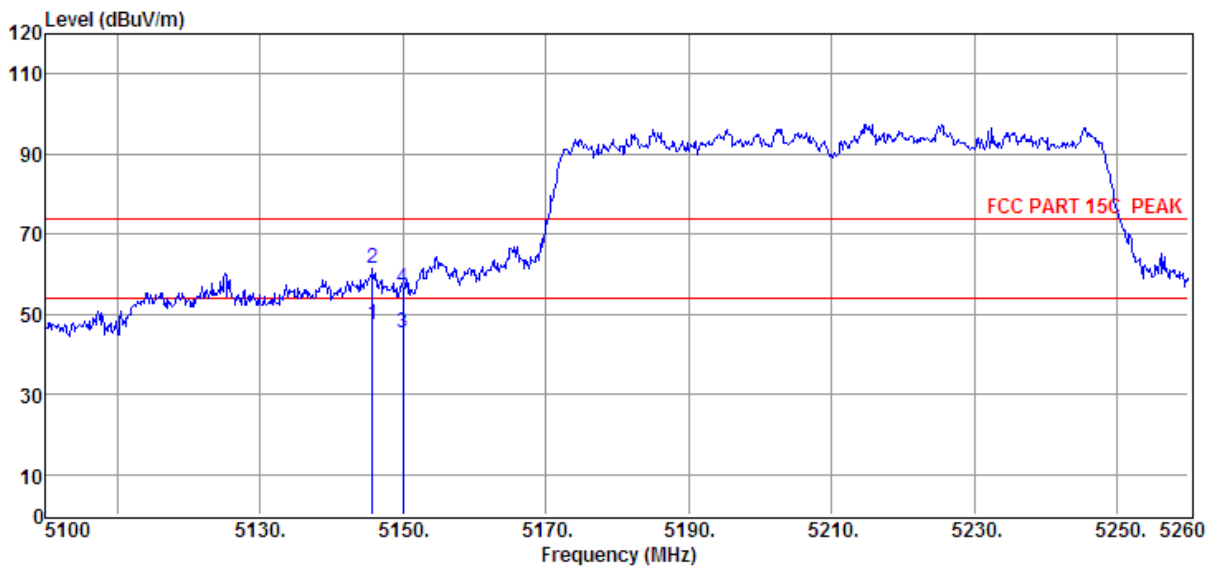

Item (Mark)	Freq. (MHz)	Read Level (dBμV)	Antenna Factor (dB/m)	PRM Factor dB	Cable Loss dB	Result Level (dBμV/m )	Limit Line (dBμV/ m)	Over Limit (dB)	Detector	Polarization
1	5145.76	48.51	35.15	43.71	7.67	47.62	54.00	-6.38	Average	VERTICAL
2	5145.76	62.33	35.15	43.71	7.67	61.44	74.00	-12.56	Peak	VERTICAL
3	5150.08	46.24	35.15	43.71	7.67	45.35	54.00	-8.65	Average	VERTICAL
4	5150.08	57.58	35.15	43.71	7.67	56.69	74.00	-17.31	Peak	VERTICAL

- Note: 1. Result Level = Read Level + Antenna Factor + Cable loss - PRM Factor.  
 2. If Peak Result complies with AV limit, AV Result is deemed to comply with AV limit.  
 3. Test setup: RBW: 1 MHz, VBW: 3 MHz, Sweep time: auto.  
 4. Test setup: RBW: 1 MHz, VBW: 10 Hz, Sweep time: auto for average measure.

# TR-4-E-009 Radiated Emission Test Result

<b>Test Site</b>	: DDT 3m Chamber 1#	<b>D:\2018 RE1# Report Data\Q18030203-1E GPON SFU ONT\RF.EM6</b>
<b>Test Date</b>	: 2018-03-29	<b>Tested By</b> : Sunny
<b>EUT</b>	: GPON SFU ONT	<b>Model Number</b> : 7285G
<b>Power Supply</b>	: AC 120V/60Hz	<b>Test Mode</b> : Tx mode
<b>Condition</b>	: Temp:24.5°C,Humi:55%, Press:100.1kPa	<b>Antenna/Distance</b> : 2017 HF907/3m/HORIZONTAL
<b>Memo</b>	: 11ac80 5210MHz	

Data: 96

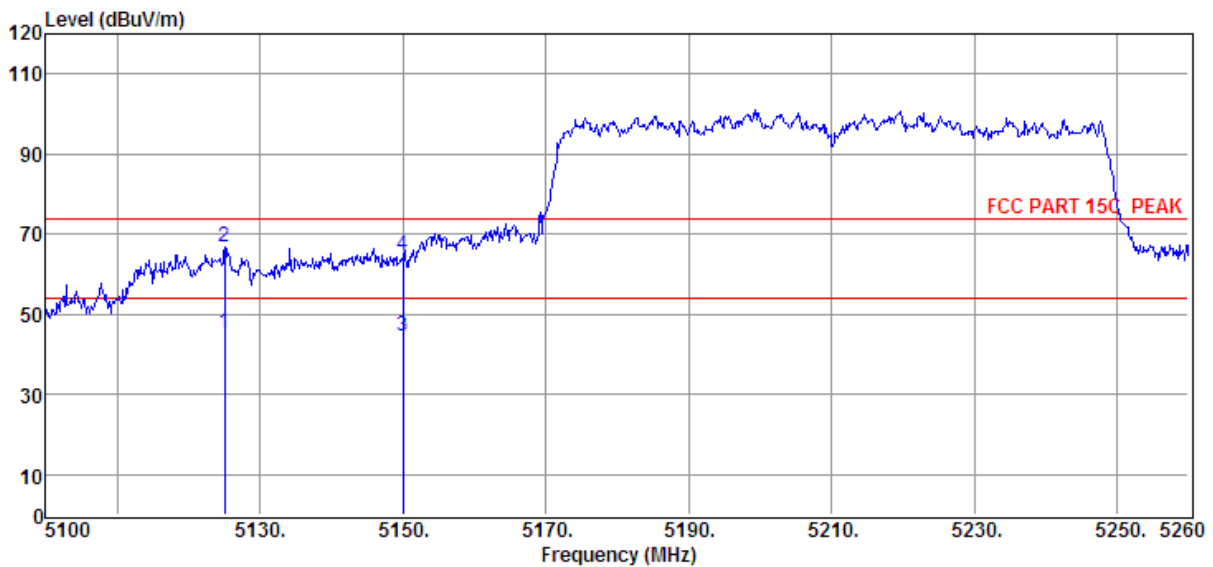

Item (Mark)	Freq. (MHz)	Read Level (dBμV)	Antenna Factor (dB/m)	PRM Factor dB	Cable Loss dB	Result Level (dBμV/m )	Limit Line (dBμV/ m)	Over Limit (dB)	Detector	Polarization
1	5125.12	46.44	35.13	43.72	7.66	45.51	54.00	-8.49	Average	HORIZONTAL
2	5125.12	67.83	35.13	43.72	7.66	66.90	74.00	-7.10	Peak	HORIZONTAL
3	5150.08	45.31	35.15	43.71	7.67	44.42	54.00	-9.58	Average	HORIZONTAL
4	5150.08	65.71	35.15	43.71	7.67	64.82	74.00	-9.18	Peak	HORIZONTAL

- Note: 1. Result Level = Read Level + Antenna Factor + Cable loss - PRM Factor.  
 2. If Peak Result complies with AV limit, AV Result is deemed to comply with AV limit.  
 3. Test setup: RBW: 1 MHz, VBW: 3 MHz, Sweep time: auto.  
 4. Test setup: RBW: 1 MHz, VBW: 10 Hz, Sweep time: auto for average measure.



## 10. Power Line Conducted Emission

### 10.1. Block diagram of test setup

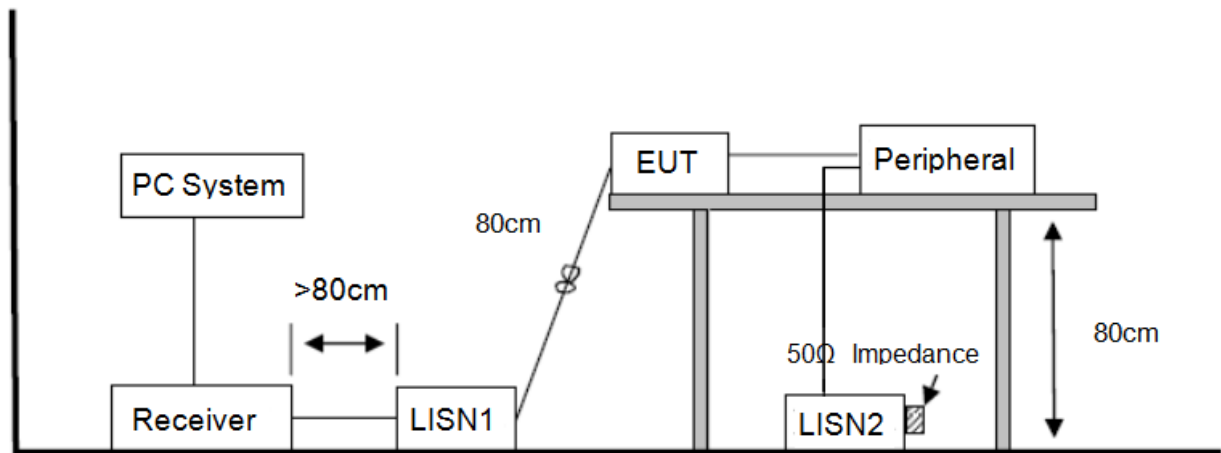

### 10.2. Power Line Conducted Emission Limits(Class B)

Frequency	Quasi-Peak Level dB( $\mu$ V)	Average Level dB( $\mu$ V)
150kHz ~ 500kHz	66 ~ 56*	56 ~ 46*
500kHz ~ 5MHz	56	46
5MHz ~ 30MHz	60	50

Note 1: \* Decreasing linearly with logarithm of frequency.

Note 2: The lower limit shall apply at the transition frequencies.

### 10.3. Test Procedure

The EUT and Support equipment, if needed, were put placed on a non-metallic table, 80cm above the ground plane.

Configuration EUT to simulate typical usage as described in clause 2.3 and test equipment as described in clause 10.2 of this report.

All I/O cables were positioned to simulate typical actual usage as per ANSI C63.4.

All support equipment power received from a second LISN.

Emissions were measured on each current carrying line of the EUT using an EMI Test Receiver connected to the LISN powering the EUT.

The Receiver scanned from 150 kHz to 30MHz for emissions in each of the test modes.

During the above scans, the emissions were maximized by cable manipulation.

The test mode(s) described in clause 2.3 were scanned during the preliminary test.

After the preliminary scan, we found the test mode producing the highest emission level.

The EUT configuration and worse cable configuration of the above highest emission levels were recorded for reference of the final test.

EUT and support equipment were set up on the test bench as per the configuration with highest emission level in the preliminary test.

A scan was taken on both power lines, Neutral and Line, recording at least the six highest emissions.

Emission frequency and amplitude were recorded into a computer in which correction factors were used to calculate the emission level and compare reading to the applicable limit.

The test data of the worst-case condition(s) was recorded.

The bandwidth of test receiver is set at 9 kHz.

#### **10.4. Test Result**

##### **PASS. (See below detailed test result)**

Note1: All emissions not reported below are too low against the prescribed limits.

Note2: "----" means peak detection; "----" means average detection

Note3: Pre-test AC conducted emission at both voltage AC 120V/60Hz and AC 240V/50Hz, recorded worst case (AC 120V/60Hz).

# TR-4-E-010 Conducted Emission Test Result

**Test Site** : DDT 1# Shield Room D:\2018 CE report data\CE.EM6  
**Test Date** : 2018-04-16 **Tested By** : Sunny  
**EUT** : GPON SFU ONT **Model Number** : 7285G  
**Power Supply** : AC 120V/60Hz **Test Mode** : Tx mode  
**Condition** : Temp:24.5°C,Humi:55%,  
**LISN** : 2017 ENV216/LINE  
 Press:100.1kPa  
**Memo** :

Data: 2

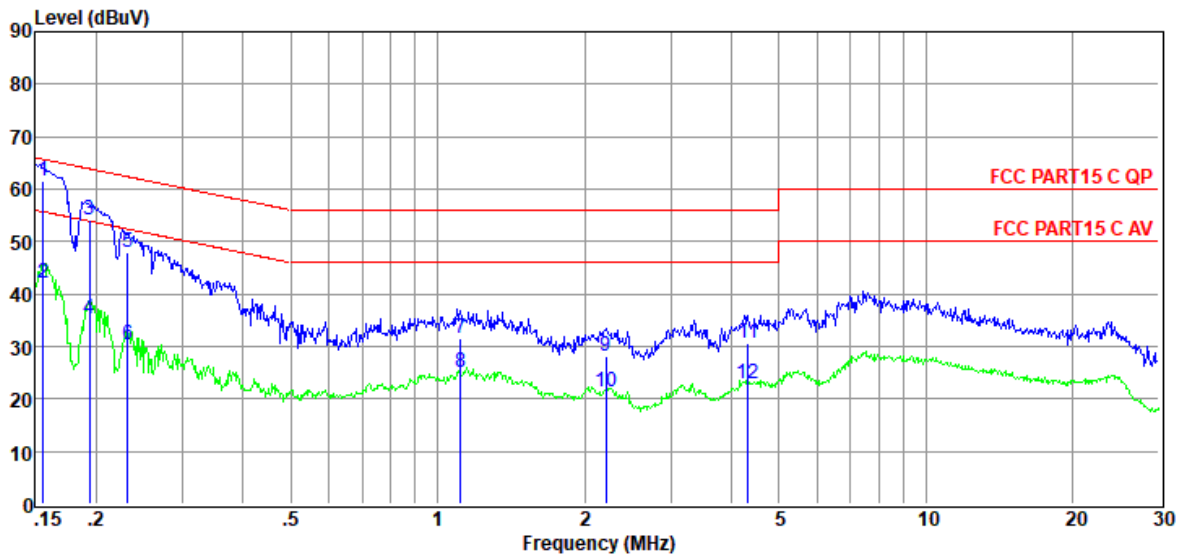

Item (Mark)	Freq. (MHz)	Read Level (dBμV)	LISN Factor (dB)	Cable Loss (dB)	Pulse Limiter Factor (dB)	Result Level (dBμV)	Limit Line (dBμV)	Over Limit (dB)	Detector	Phase
1	0.16	42.05	9.52	0.04	9.86	61.47	65.69	-4.22	QP	LINE
2	0.16	22.58	9.52	0.04	9.86	42.00	55.69	-13.69	Average	LINE
3	0.19	34.68	9.51	0.04	9.86	54.09	63.89	-9.80	QP	LINE
4	0.19	15.76	9.51	0.04	9.86	35.17	53.89	-18.72	Average	LINE
5	0.23	28.43	9.52	0.04	9.86	47.85	62.39	-14.54	QP	LINE
6	0.23	10.81	9.52	0.04	9.86	30.23	52.39	-22.16	Average	LINE
7	1.12	12.13	9.57	0.14	9.86	31.70	56.00	-24.30	QP	LINE
8	1.12	5.46	9.57	0.14	9.86	25.03	46.00	-20.97	Average	LINE
9	2.21	8.45	9.60	0.12	9.87	28.04	56.00	-27.96	QP	LINE
10	2.21	1.68	9.60	0.12	9.87	21.27	46.00	-24.73	Average	LINE
11	4.32	11.15	9.64	0.10	9.87	30.76	56.00	-25.24	QP	LINE
12	4.32	3.20	9.64	0.10	9.87	22.81	46.00	-23.19	Average	LINE

- Note: 1. Result Level = Read Level + LISN Factor + Pulse Limiter Factor + Cable loss.  
 2. If QP Result complies with AV limit, AV Result is deemed to comply with AV limit.  
 3. Test setup: RBW: 200 Hz (9 kHz—150 kHz), 9 kHz (150 kHz—30 MHz).  
 4. Step size: 80Hz (0.009MHz-0.15MHz), 4 kHz (0.15MHz-30MHz), Scan time: auto.

# TR-4-E-010 Conducted Emission Test Result

**Test Site** : DDT 1# Shield Room D:\2018 CE report data\CE.EM6  
**Test Date** : 2018-04-16 **Tested By** : Sunny  
**EUT** : GPON SFU ONT **Model Number** : 7285G  
**Power Supply** : AC 120V/60Hz **Test Mode** : Tx mode  
**Condition** : Temp:24.5°C,Humi:55%,  
**LISN** : 2017 ENV216/NEUTRAL  
 Press:100.1kPa  
**Memo** :

Data: 4

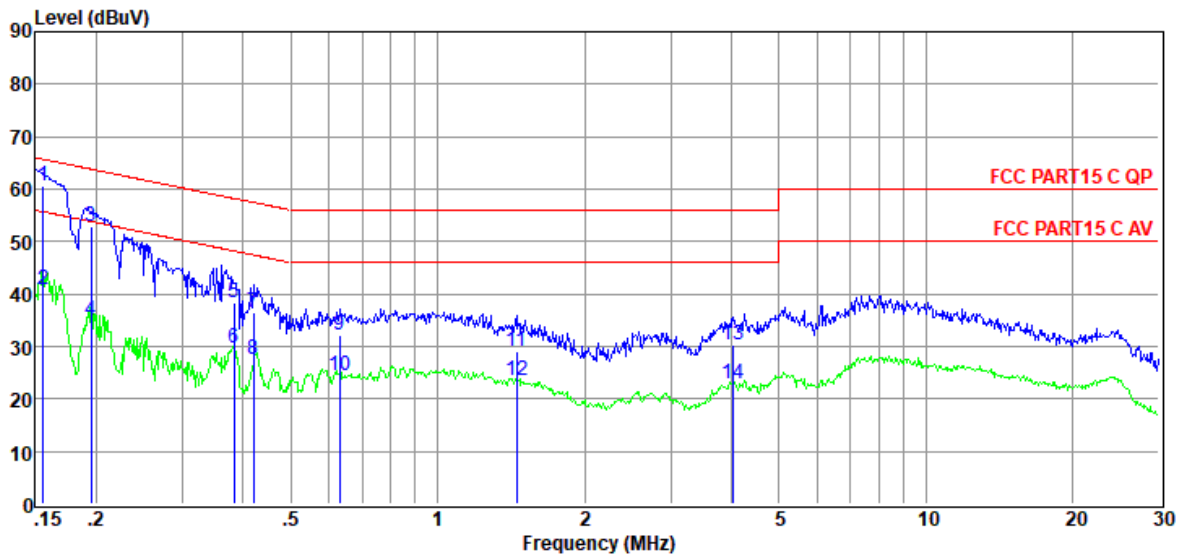

Item (Mark)	Freq. (MHz)	Read Level (dBμV)	LISN Factor (dB)	Cable Loss (dB)	Pulse Limiter Factor (dB)	Result Level (dBμV)	Limit Line (dBμV)	Over Limit (dB)	Detector	Phase
1	0.16	41.34	9.48	0.04	9.86	60.72	65.69	-4.97	QP	NEUTRAL
2	0.16	21.33	9.48	0.04	9.86	40.71	55.69	-14.98	Average	NEUTRAL
3	0.20	33.60	9.45	0.04	9.86	52.95	63.80	-10.85	QP	NEUTRAL
4	0.20	15.69	9.45	0.04	9.86	35.04	53.80	-18.76	Average	NEUTRAL
5	0.38	19.00	9.37	0.04	9.83	38.24	58.21	-19.97	QP	NEUTRAL
6	0.38	10.50	9.37	0.04	9.83	29.74	48.21	-18.47	Average	NEUTRAL
7	0.42	17.19	9.37	0.04	9.82	36.42	57.44	-21.02	QP	NEUTRAL
8	0.42	8.21	9.37	0.04	9.82	27.44	47.44	-20.00	Average	NEUTRAL
9	0.63	12.80	9.33	0.07	9.84	32.04	56.00	-23.96	QP	NEUTRAL
10	0.63	5.34	9.33	0.07	9.84	24.58	46.00	-21.42	Average	NEUTRAL
11	1.45	9.90	9.28	0.13	9.86	29.17	56.00	-26.83	QP	NEUTRAL
12	1.45	4.30	9.28	0.13	9.86	23.57	46.00	-22.43	Average	NEUTRAL

- Note: 1. Result Level = Read Level + LISN Factor + Pulse Limiter Factor + Cable loss.  
 2. If QP Result complies with AV limit, AV Result is deemed to comply with AV limit.  
 3. Test setup: RBW: 200 Hz (9 kHz—150 kHz), 9 kHz (150 kHz—30 MHz).  
 4. Step size: 80Hz (0.009MHz-0.15MHz), 4 kHz (0.15MHz-30MHz), Scan time: auto.

## **11. Antenna Requirements**

### **11.1. Limit**

For intentional device, according to FCC 47 CFR Section 15.203, an intentional radiator shall be designed to ensure that no antenna other than that furnished by the responsible party shall be used with the device. And according to FCC 47 CFR Section 15.407 (a), if transmitting antennas of directional gain greater than 6dBi are used, the power shall be reduced by the amount in dB that the directional gain of the antenna exceeds 6dBi.

### **11.2. Result**

The antennas used for this product are integrated antenna and other than that furnished by the responsible party shall be used with the device, the maximum peak gain of the transmit antenna is 8.74dBi.

**END OF REPORT**