



FCC/IC - TEST REPORT

Report Number : **68.910.19.0013.01** Date of Issue: February 27, 2020

Model : MT01-1335-069001, MT01-1345-069001, MT01-1345-069002

Product Type : Tubular motor

Applicant : Rollease Acmeda Inc

Address : 750 East Main Street, 7th Floor, Stamford Connecticut

: United States 06902

Production Facility : Ningbo Dooya Mechanic & Electronic Technology Co., Ltd.

Address : No.168 Shengguang Road, Luotuo, Zhenhai, Ningbo,

: Zhejiang province, P.R.China 315202

Test Result : **Positive** **Negative**

Total pages including Appendices : 19

TÜV SÜD Certification and Testing (China) Co., Ltd. Shenzhen Branch is a subcontractor to TÜV SÜD Product Service GmbH according to the principles outlined in ISO 17025.

TÜV SÜD Certification and Testing (China) Co., Ltd. Shenzhen Branch reports apply only to the specific samples tested under stated test conditions. Construction of the actual test samples has been documented. It is the manufacturer's responsibility to assure that additional production units of this model are manufactured with identical electrical and mechanical components. The manufacturer/importer is responsible to the Competent Authorities in Europe for any modifications made to the production units which result in non-compliance to the relevant regulations. TÜV SÜD Certification and Testing (China) Co., Ltd. Shenzhen Branch shall have no liability for any deductions, inferences or generalizations drawn by the client or others from TÜV SÜD Certification and Testing (China) Co., Ltd. Shenzhen Branch issued reports.

This report is the confidential property of the client. As a mutual protection to our clients, the public and ourselves, extracts from the test report shall not be reproduced except in full without our written approval



1 Table of Contents

1	Table of Contents	2
2	Details about the Test Laboratory.....	3
3	Description of the Equipment Under Test.....	4
4	Summary of Test Standards	5
5	Summary of Test Results	6
6	General Remarks	7
7	Systems test configuration	8
8	Test Setups	9
9	Test Methodology.....	10
9.1	Conducted Emission.....	10
9.2	Radiated Emission.....	13
9.3	Bandwidth Measurement	16
9.4	Deactivation Time.....	17
10	Test Equipment List.....	18
11	System Measurement Uncertainty.....	19

2 Details about the Test Laboratory

Details about the Test Laboratory

Test Site 1

Company name: TÜV SÜD Certification and Testing (China) Co., Ltd. Shenzhen Branch
Building 12&13, Zhiheng Wisdomland Business Park,
Nantou Checkpoint Road 2, Nanshan District,
Shenzhen City, 518052,
P. R. China

FCC Registration Number: 514049

IC Registration Number: 10320A

Telephone: 86 755 8828 6998
Fax: 86 755 8828 5299

3 Description of the Equipment Under Test

Product: Tubular motor

Model no./HVIN/PMN: MT01-1335-069001, MT01-1345-069001, MT01-1345-069002

FCC ID: 2AGGZMT011335069001

IC: 21769-MT011335001

Ratings: 5VDC, 2.2A, 26W (Supplied by USB Port)
10.8VDC (Supplied by rechargeable battery)

RF Transmission Frequency: 433.925MHz

Modulation: FSK

Antenna Type: Line Antenna

Antenna Gain: 0dBi

Description of the EUT: The Equipment Under Test (EUT) is a Tubular motor operated at 433.925MHz

4 Summary of Test Standards

Test Standards	
FCC Part 15 Subpart C 10-1-2017 Edition	PART 15 - RADIO FREQUENCY DEVICES Subpart C - Intentional Radiators
RSS-Gen Issue 5 March 2019 Amendment 1	General Requirements and Information for the Certification of Radio Apparatus
RSS-210 Issue 9 August 2016	RSS-210 — Licence-exempt Radio Apparatus (All Frequency Bands): Category I Equipment

All the test methods were according to ANSI C63.10-2013.

5 Summary of Test Results

Technical Requirements					
FCC Part 15 Subpart C, RSS-210 Issue 9					
Test Condition			Pages	Test Site	Test Result
§15.207	RSS-GEN A8.8	Conducted emission AC power port	10	Site 1	Pass
§15.205, §15.209, 15.35 (c)§15.231(b)	RSS-210 A.1.2	Radiated Emission, 30MHz to 4.5GHz	13	Site 1	Pass
§15.231(c)	RSS-210 A.1.3	Bandwidth Measurement	16	Site 1	Pass
§15.231(a)(1)	RSS-210 A.1.1(a)	Deactivation Time	17	Site 1	Pass
§15.203	RSS-Gen 6.8	Antenna requirement	--	See Note 2	Pass

Note 1: N/A=Not Applicable.

Note 2: The EUT uses a Line Antenna, which gain is 0dBi. In accordance to §15.203, It is considered sufficiently to comply with the provisions of this section.

6 General Remarks

Remarks

This submittal(s) (test report) is intended for FCC ID: 2AGGZMT011335069001, IC: 21769-MT011335001 complies with Section 15.205, 15.207, 15.209, 15.231 of the FCC Part 15, Subpart C Rules, RSS-Gen Issue 5 and RSS-210 issue 9.

three models are identical except for different lies only in the height of motor, So all the tests were applied on MT01-1335-069001, other models are deemed to fulfil the EMC test without further testing.

SUMMARY:

All tests according to the regulations cited on page 5 were.

n - Performed

o - **Not** Performed

The Equipment Under Test

n - **Fulfills** the general approval requirements.

o - **Does not** fulfill the general approval requirements.

Sample Received Date: March 13, 2019

Testing Start Date: March 13, 2019

Testing End Date: April 25, 2019

TÜV SÜD Certification and Testing (China) Co., Ltd. Shenzhen Branch

Reviewed by:

Prepared by:

Tested by:



John Zhi
EMC Project Manager



Mark Chen
EMC Project Engineer



Carry Cai
EMC Test Engineer



7 Systems test configuration

Auxiliary Equipment Used during Test:

DESCRIPTION	MANUFACTURER	MODEL NO.(SHIELD)	S/N(LENGTH)
--	--	--	--

8 Test Setups

8.1 Radiated test setups

Below 1GHz

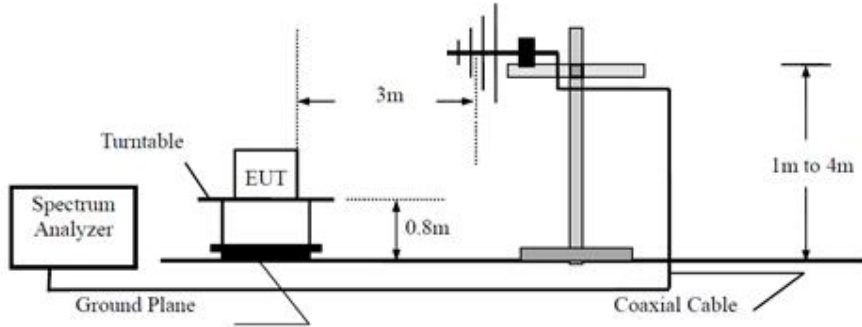

Above 1GHz

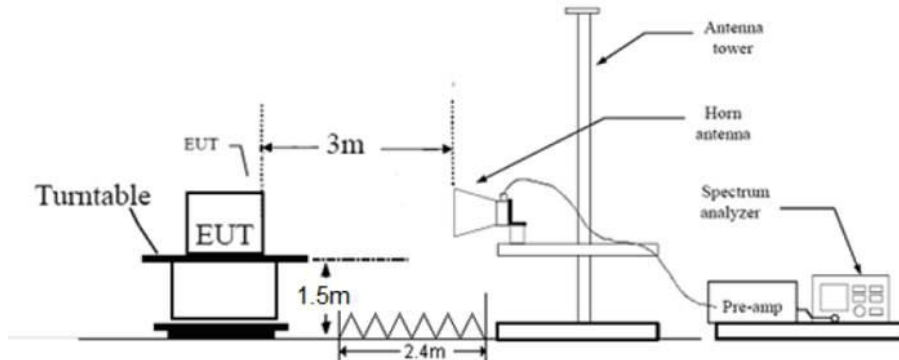

8.2 Conducted RF test setups

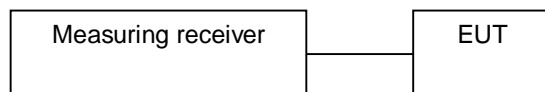

8.3 AC Power Line Conducted Emission test setups

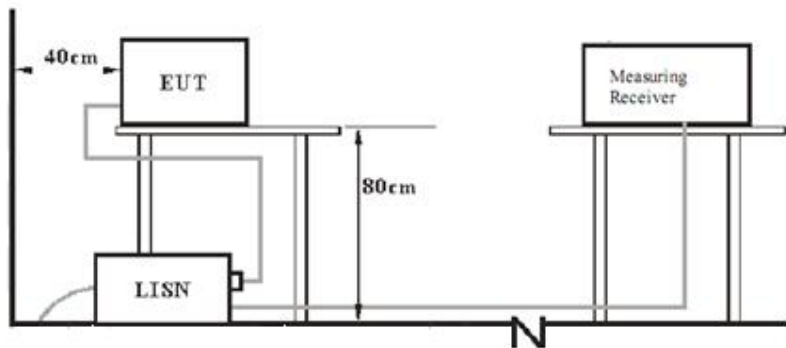



9 Test Methodology

9.1 Conducted Emission

Test Method

1. The EUT was placed 0.4 meter from the conducting wall of the shielding room was kept at least 80 centimeters from any other grounded conducting surface.
2. Connect EUT to the power mains through a line impedance stabilization network (LISN).
3. All the support units are connecting to the other LISN.
4. The LISN provides 50 ohm coupling impedance for the measuring instrument.
6. Both sides of AC line were checked for maximum conducted interference.
7. The frequency range from 150 kHz to 30 MHz was searched.
8. Set the test-receiver system to Peak Detect Function and specified bandwidth (IF Bandwidth = 9kHz) with Maximum Hold Mode. Then measurement is also conducted by Average Detector and Quasi-Peak Detector Function respectively.

Limit

Frequency MHz	QP Limit dB μ V	AV Limit dB μ V
0.150-0.500	66-56*	56-46*
0.500-5	56	46
5-30	60	50

*Decreasing linearly with logarithm of the frequency.

Conducted Emission Test 0.15MHz – 30MHz

EUT: Tubular motor
 M/N: MT01-1335-069001
 Operating Condition: TX
 Test Specification: Power Line, Live
 Comment: AC120V/60Hz

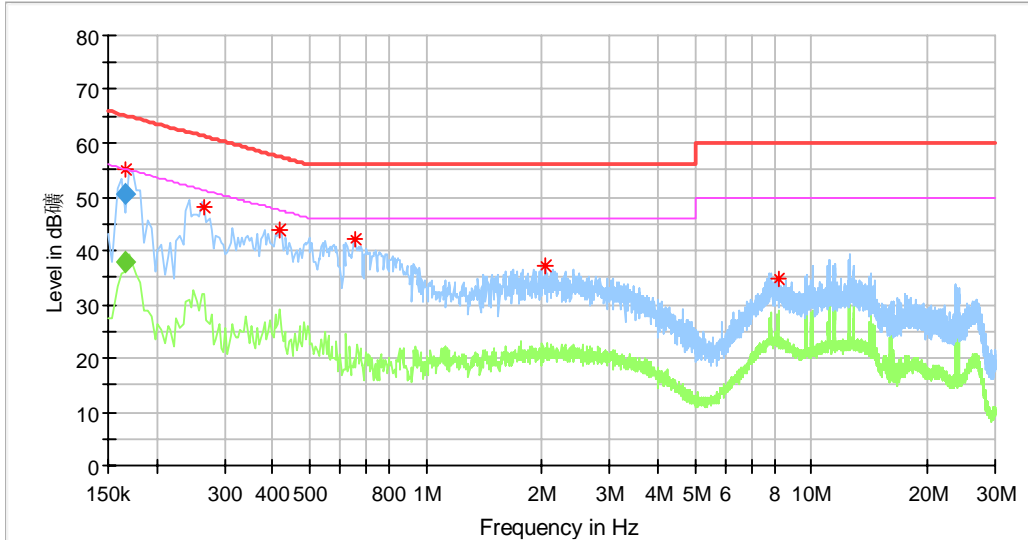

Critical Freqs

Frequency (MHz)	MaxPeak (dBµV)	Average (dBµV)	Limit (dBµV)	Margin (dB)	Line	Corr. (dB/m)
0.165500	55.24	---	64.96	9.72	L1	10.2
0.266000	48.12	---	61.24	13.13	L1	10.2
0.418000	43.69	---	57.49	13.80	L1	10.3
0.654000	42.08	---	56.00	13.92	L1	10.3
2.042000	37.25	---	56.00	18.75	L1	10.3
8.186000	34.68	---	60.00	25.32	L1	10.6

Final Result

Frequency (MHz)	QuasiPeak (dBµV)	Average (dBµV)	Limit (dBµV)	Margin (dB)	Line	Corr. (dB/m)
0.165500	---	37.99	55.18	17.19	L1	10.2
0.165500	50.52	---	65.18	14.66	L1	10.2

Remark:
 Level=Reading Level + Correction Factor
 Correction Factor=Cable Loss + LISN Factor
 (The Reading Level is recorded by software which is not shown in the sheet)

Conducted Emission Test 0.15MHz – 30MHz

EUT: Tubular motor
 M/N: MT01-1335-069001
 Operating Condition: TX
 Test Specification: Power Line, Neutral
 Comment: AC120V/60Hz

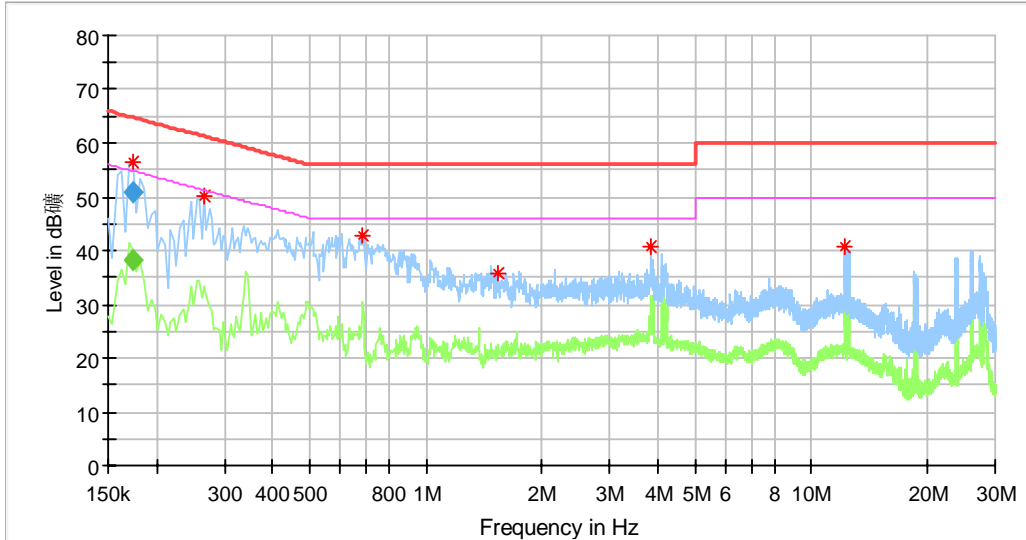

Critical Freqs

Frequency (MHz)	MaxPeak (dBµV)	Average (dBµV)	Limit (dBµV)	Margin (dB)	Line	Corr. (dB/m)
0.173500	56.64	---	64.96	8.32	N	10.2
0.266000	50.22	---	61.24	11.02	N	10.2
0.686000	42.89	---	56.00	13.11	N	10.3
1.542000	35.65	---	56.00	20.35	N	10.3
3.818000	40.84	---	56.00	15.16	N	10.4
12.246000	40.60	---	60.00	19.40	N	10.7

Final Result

Frequency (MHz)	QuasiPeak (dBµV)	Average (dBµV)	Limit (dBµV)	Margin (dB)	Line	Corr. (dB/m)
0.173500	---	38.38	54.79	16.41	N	10.2
0.173500	51.04	---	64.79	13.75	N	10.2

Remark:

Level=Reading Level + Correction Factor

Correction Factor=Cable Loss + LISN Factor

(The Reading Level is recorded by software which is not shown in the sheet)

9.2 Radiated Emission

Test Method

- 1: The EUT was placed on a turn table which is 1.5m above ground plane for above 1GHz and 0.8m above ground for below 1GHz at 3 meter chamber room for test. The table was rotated 360 degrees to determine the position of the highest radiation.
- 2: The EUT was set 3 meters away from the interference – receiving antenna, which was mounted on the top of a variable – height antenna tower.
- 3: The height of antenna is varied from one meter to four meters above the ground to determine the maximum value of the field strength. Both horizontal and vertical polarizations of the antenna are set to make the measurement.
- 4: For each suspected emission, the EUT was arranged to its worst case and then the antenna was tuned to heights from 1 meter to 4 meters and the rotatable table was turned from 0 degrees to 360 degrees to find the maximum reading.
- 5: Use the following spectrum analyzer settings According to C63.10:
For Below 1GHz
Use the following spectrum analyzer settings:
Span = wide enough to capture the peak level of the in-band emission and all spurious
RBW = 100 KHz to 120KHz, VBW \geq RBW for peak measurement, Sweep = auto,
Detector function = peak, Trace = max hold.
For Peak unwanted emissions Above 1GHz:
Span = wide enough to capture the peak level of the in-band emission and all spurious
RBW = 1MHz, VBW \geq RBW for peak measurement, Sweep = auto,
Detector function = peak, Trace = max hold.
Procedures for average unwanted emissions measurements above 1000 MHz:
Span = wide enough to capture the peak level of the in-band emission and all spurious
RBW = 1MHz, VBW=10Hz, Sweep = auto, Detector function = peak, Trace = max hold.
If the dwell time per channel of the hopping signal is less than 100 ms, then the reading obtained with the 10 Hz VBW may be further adjusted by a “duty cycle correction factor”, derived from $20\log(\text{dwell time}/100 \text{ ms})$, in an effort to demonstrate compliance with the limit.
If the emission is pulsed, modify the unit for continuous operation; use the settings shown above, then correct the reading by subtracting the peak-average correction factor, derived from the appropriate duty cycle calculation.

Limit

According to §15.231 (b), the and RSS-210 A.1.2 field strength of emissions from intentional radiators operated under this section shall not exceed the following:

Fundamental frequency (MHz)	Field Strength of Fundamental (Microvolts /meter)	Field Strength of spurious emissions ((Microvolts /meter)
40.66-40.70	2,250	225
70-130	1,250	125
130-174	1,250 to 3,370 *	125 to 375 *
174-260	3,750	375
260-470 √	3,750 to 12, 500*	375 to 1,250*
Above 470	12,500	1,250



Spurious radiated emissions for transmitter

According to C63.10, if the peak (or quasi-peak) measured value complies with the average limit, it is unnecessary to perform an average measurement, so AV emission value did not show in below table if the peak value complies with average limit.

Radiated Emission									
Value	Emissions Frequency MHz	E-Field Polarity	PK Emission dBµV/m	Corr.	Average Factor dB	AV Emission dBµV/m	Limit dBµV/m	Margin	Emission Type
Below 1GHz									
PK	433.925	H	89.85	-29.6	0.00	/	100.83	10.98	Fundamental
AV	433.925	H	89.85	/	-22.29	67.56	80.83	13.27	Fundamental
PK	433.925	V	87.96	-23.3	0.00	/	100.83	12.87	Fundamental
AV	433.925	V	87.96	/	-22.29	65.67	80.83	15.16	Fundamental
PK	869.85	H	67.26	-16.0	0.00	/	80.83	13.57	Spurious
AV	869.85	H	67.26	/	-22.29	44.97	60.83	15.86	Spurious
PK	869.85	V	62.95	-16.0	0.00	/	80.83	17.88	Spurious
AV	869.85	V	62.95	/	-22.29	40.66	60.83	20.17	Spurious
Above 1GHz									
PK	4773.175	H	48.27	2.6	0.00	/	74.00	25.73	Spurious
AV	4773.175	H	48.27	/	-22.29	25.98	54.00	28.02	Spurious
PK	4773.175	V	48.07	2.6	0.00	/	74.00	25.93	Spurious
AV	4773.175	V	48.07	/	-22.29	25.78	54.00	28.22	Spurious

Remark:

- 1: AV Emission Level= PK Emission Level+20log(dutycycle)
- 2: Data of measurement within this frequency range shown " / " in the table above means the reading of emissions are attenuated more than 20db below the permissible limits or the field strength is too small to be measured.
- 3: "*" means the emission(s) appear within the restrict bands shall follow the requirement of section 15.205.
- 4: Level= Reading Level + Correction Factor
Correction Factor = Antenna Factor + Cable Loss- Amplifier Gain
(The Reading Level is recorded by software which is not shown in the sheet)

Duty Cycle = 7.681(ms)/100(ms) = 7.681%
Duty Cycle Factor = 20log (Duty Cycle) = -22.29

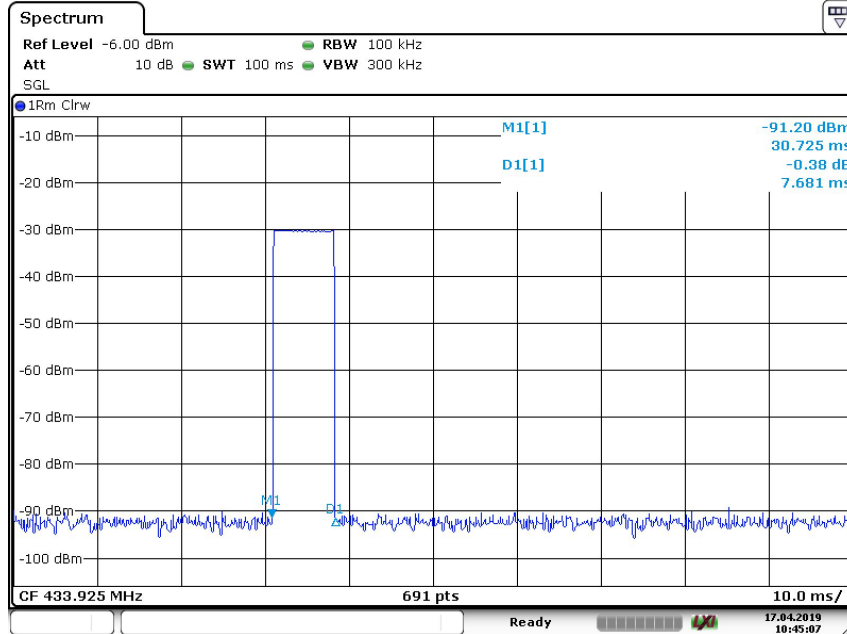

Date: 17.APR.2019 10:45:08

9.3 Bandwidth Measurement

Test Method

1. The EUT was placed on 0.8m height table, the RF output of EUT was connected to the test receiver by RF cable. The path loss was compensated to the results for each measurement.
2. Set to the maximum power setting and enable the EUT transmit continuously.
3. Use the following test receiver settings:
Span = approximately 5 times the 20dB bandwidth, centered on a hopping channel
RBW > the 20dB bandwidth of the emission being measured, VBW ≥ RBW,
Sweep = auto, Detector function = peak, Trace = max hold
4. Allow the trace to stabilize. Use the marker-to-peak function to set the marker to the peak of the emission. Measure the frequency difference of two frequencies that were attenuated 20 dB from the reference level. Record the frequency difference as the emission bandwidth. Record the results.
5. Repeat above procedures until all frequencies measured were complete.

Limit

The bandwidth of the emission shall be no wider than 0.25% of the center frequency for devices operating above 70MHz and below 900MHz. For devices operating above 900MHz, the emission shall be no wider than 0.5% of the center frequency. Bandwidth is determined at the points 20dB down from the modulated carrier.

The limit for the EUT = 0.25% * 433.925 MHz = 1084 kHz

Test Result

Channel	20dB Bandwidth (KHz)	99% bandwidth (KHz)	Limit (KHz)
1	81.04KHz	77.42	1084

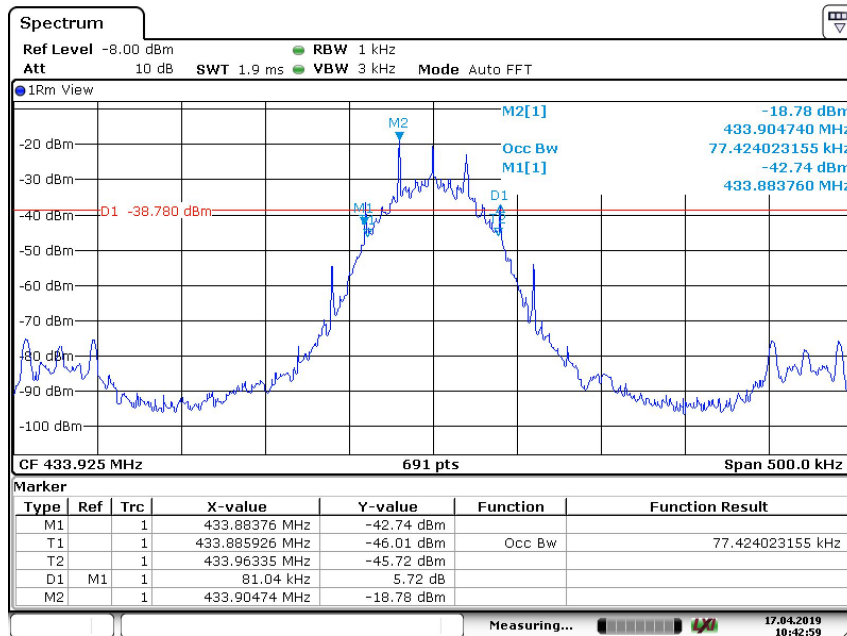

Date: 17.APR.2019 10:43:00

9.4 Deactivation Time

Test Method

1. The EUT was placed on 0.8m height table, the RF output of EUT was connected to the test receiver by RF cable. The path loss was compensated to the results for each measurement.
2. Set to the maximum power setting and enable the EUT in transmitting mode.
3. Set center frequency of spectrum analyzer=operating frequency.
4. Set the spectrum analyzer as $RBW \geq OBW$, $VBW \geq RBW$, Span=0Hz, detector=peak.
5. Repeat above procedures until all frequency measured was complete.

Limit

According to FCC Part 15.231 (a), the transmitter shall be complied the following requirements:

- (√) (1) A manually operated transmitter shall employ a switch that will automatically deactivate the transmitter within not more than 5 seconds of being released.
- (2) A transmitter activated automatically shall cease transmission within 5 seconds after activation.
- (3) Periodic transmissions at regular predetermined intervals are not permitted. However, polling or supervision transmissions, including data, to determine system integrity of transmitters used in security or safety applications are allowed if the total duration of transmissions does not exceed more than two seconds per hour for each transmitter. There is no limit on the number of individual transmissions, provided the total transmission time does not exceed two seconds per hour.

Test Result

Channel	Frequency	Deactivation Time	Result
1	433.925MHz	840.6ms	Pass

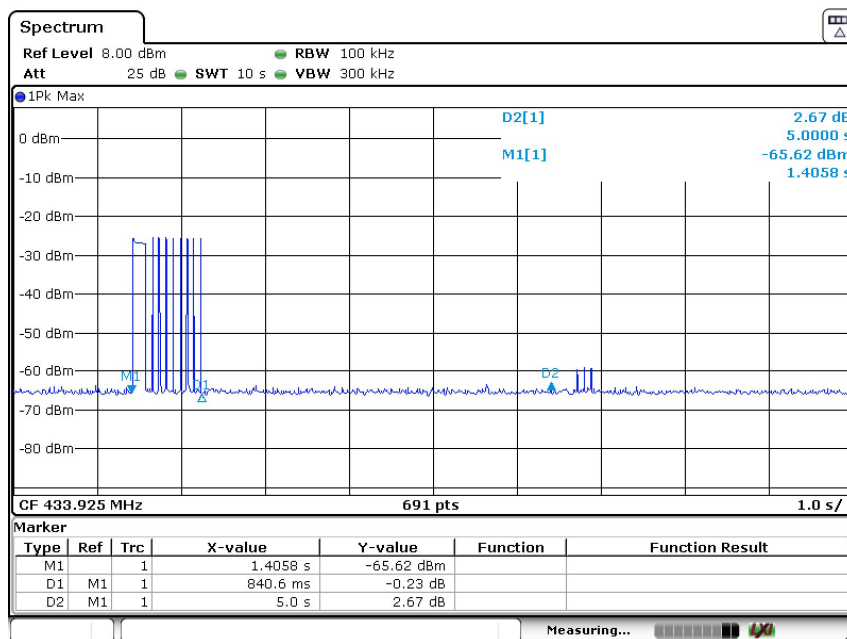

Date: 13.APR.2020 15:14:09

10 Test Equipment List

List of Test Instruments

Radiated Spurious Emission Test

Description	Manufacturer	Model no.	Equipment ID	Serial no.	cal. due date
Signal Analyzer	Rohde & Schwarz	FSV40	68-4-74-14-003	101031	2020-6-28
Trilog Super Broadband Test Antenna	Schwarzbeck	VULB 9163	68-4-80-14-003	708	2020-7-5
Horn Antenna	Rohde & Schwarz	HF907	68-4-80-14-004	102295	2020-7-5
Wideband Horn Antenna	Q-PAR	QWH-SL-18-40-K-SG	68-4-80-14-008	12827	2020-7-5
Loop Antenna	Rohde & Schwarz	HFH2-Z2	68-4-80-14-006	100398	2020-7-7
Pre-amplifier	Rohde & Schwarz	SCU 18	68-4-29-14-001	102230	2020-6-28
Pre-amplifier	Rohde & Schwarz	SCU 40A	68-4-29-14-002	100432	2020-7-16
Fully Anechoic Chamber	TDK	8X4X4	68-4-90-14-002	--	2020-7-7
Test software	Rohde & Schwarz	EMC32	68-4-90-14-002-A10	Version 9.15.00	N/A

Conducted Emission Test

Description	Manufacturer	Model no.	Equipment ID	Serial no.	cal. due date
EMI Test Receiver	Rohde & Schwarz	ESR 3	68-4-74-14-001	101782	2020-6-28
LISN	Rohde & Schwarz	ENV4200	8-4-87-14-001	100249	2020-6-28
LISN	Rohde & Schwarz	ENV432	68-4-87-16-001	101318	2020-7-19
LISN	Rohde & Schwarz	ENV216	68-4-87-14-002	100326	2020-6-28
ISN	Rohde & Schwarz	ENY81	68-4-87-14-003	100177	2020-6-28
ISN	Rohde & Schwarz	ENY81-CA6	68-4-87-14-004	101664	2020-6-28
High Voltage Probe	Rohde & Schwarz	TK9420(VT9420)	68-4-27-14-001	9420-584	2020-6-24
RF Current Probe	Rohde & Schwarz	EZ-17	68-4-27-14-002	100816	2020-7-2
Attenuator	Shanghai Huaxiang	TS2-26-3	68-4-81-16-003	080928189	2020-6-28
Test software	Rohde & Schwarz	EMC32	68-4-90-14-003-A10	Version9.15.00	N/A

RF Test System

Description	Manufacturer	Model no.	Equipment ID	Serial no.	cal. due date
Signal Analyzer	Rohde & Schwarz	FSV40	68-4-74-14-004	101030	2020-6-28

11 System Measurement Uncertainty

For a 95% confidence level, the measurement expanded uncertainties for defined systems, in accordance with the recommendations of ISO 17025 were:

System Measurement Uncertainty	
Test Items	Extended Uncertainty
Uncertainty for Radiated Emission in 3m chamber 30MHz-1000MHz	Horizontal: 4.81dB; Vertical: 4.89dB;
Uncertainty for Radiated Spurious Emission 25MHz-3000MHz	Horizontal: 4.69dB; Vertical: 4.68dB;
Uncertainty for Radiated Spurious Emission 3000MHz-18000MHz	Horizontal: 4.89dB; Vertical: 4.87dB;
Uncertainty for Radiated Spurious Emission 18000MHz-40000MHz	Horizontal: 4.81dB; Vertical: 4.89dB;
Uncertainty for Conducted Emission 150kHz-30MHz (for test using AMN ENV432 or ENV4200)	3.21dB