

# AUTOMATE™ V2

## MOTOR PROGRAMMING INSTRUCTIONS

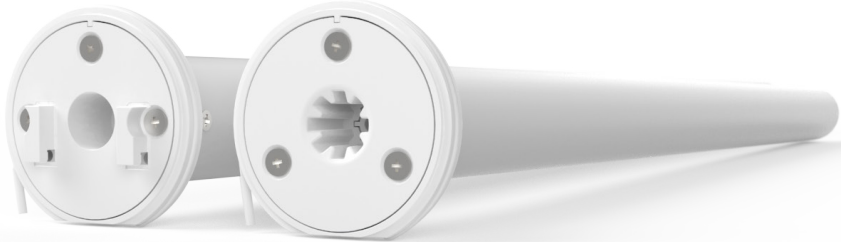

SOFT STOP



ELECTRONIC  
LIMIT



SELECTABLE  
SPEED



433 MHZ  
BI-DIRECTIONAL



FAVORITE  
POSITION



BATTERY CHECK



USB CHARGE



SOLAR OPTION



LEVEL CONTROL



BATTERY  
POWERED

- USE THIS DOCUMENT WITH THE FOLLOWING MOTORS:

PART NUMBER	DESCRIPTION
MT01-1325-069001	AUTOMATE   Li-ion 1.1Nm ARC Motor [Ø25/5V/20rpm] [Skyline Short]
MT01-1325-069002	AUTOMATE   Li-ion 1.1Nm ARC Motor [Ø25/5V/20rpm] [Skyline]
MT01-1325-069003	AUTOMATE   Li-ion 1.1Nm ARC Motor [Ø25/5V/20rpm] [S45]
MT01-1325-069005	AUTOMATE   Li-ion 1.1Nm ARC Motor [Ø25/5V/20rpm] [S45 Short]
MT01-1328-069001	AUTOMATE   Li-ion 2.0Nm ARC Motor [Ø28/5V/20rpm] [Skyline]
MT01-1328-069002	AUTOMATE   Li-ion 2.0Nm ARC Motor [Ø28/5V/20rpm] [S45]
MT01-1335-069001	AUTOMATE   Li-ion 3.0Nm ARC Motor [Ø35/5V/20rpm]
MT01-1345-069001	AUTOMATE   Li-ion Q3.0Nm ARC Motor [Ø45/5V/20rpm]
MT01-1345-069002	AUTOMATE   Li-ion 10.0Nm ARC Motor [Ø45/5V/9rpm]



# SAFETY INSTRUCTIONS

## WARNING: Important safety instructions to be read before installation.

Incorrect installation can lead to serious injury and will void manufacturer's liability and warranty.

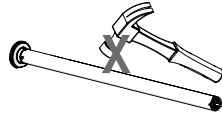
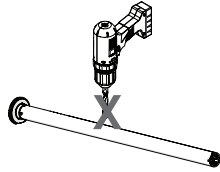

### WARNING: Important safety instructions to be read before installation and use.

Incorrect installation or use can lead to serious injury and will void manufacturer's liability and warranty.

It is important for the safety of persons to follow the enclosed instructions. Save these instructions for future reference.

- Do not expose to water, moisture, humid and damp environments or extreme temperatures.
- Persons (including children) with reduced physical, sensory or mental capabilities, or lack of experience and knowledge should not be allowed to use this product.
- Use or modification outside the scope of this instruction manual will void warranty.
- Installation and programming to be performed by a suitably qualified installer.
- Follow installation instructions.
- For use with motorized shading devices.
- Keep away from children.
- Frequently inspect for improper operation. Do not use if repair or adjustment is necessary.
- Keep clear when in operation.
- Replace battery with correctly specified type.

Rollase Acmeda declares this equipment is in compliance with the essential requirements and other relevant provisions of R&TT EC Directive 1999/5/EC

### Statement Regarding FCC Compliance

This device complies with Part 15 of the FCC Rules. Operation is subject to the following two conditions:

- (1) This device may not cause harmful interference, and
- (2) This device must accept any interference received, including interference that may cause undesired operation.

#### Note:

This equipment has been tested and found to comply with the limits for a Class B digital device, pursuant to Part 15 of the FCC Rules. These limits are designed to provide reasonable protection against harmful interference in a residential installation. This equipment generates, uses and can radiate radio frequency energy and, if not installed and used in accordance with the instructions, may cause harmful interference to radio communications. However, there is no guarantee that interference will not occur in a particular installation. If this equipment does cause harmful interference to radio or television reception, which can be determined by turning the equipment off and on, the user is encouraged to try to correct the interference by one or more of the following measures:

- Reorient or relocate the receiving antenna.
- Increase the separation between the equipment and receiver.
- Connect the equipment into an outlet on a circuit different from that to which the receiver is connected.
- Consult the dealer or an experienced radio/TV technician for help.

Any changes or modifications not expressly approved by the party responsible for compliance could void the user's authority to operate the equipment.

### Statement Regarding IC Compliance

1. This device complies with Industry Canada RSS standard(s). Operation is subject to the following two conditions: (1) this device may not cause interference, and (2) this device must accept any interference, including interference that may cause undesired operation of the device.

2. Changes or modifications not expressly approved by the party responsible for compliance could void the user's authority to operate the equipment.

-French:

Le présent appareil est conforme aux CNR d'Industrie Canada applicable aux appareils radio

Exempts de licence. L'exploitation est autorisée aux deux conditions suivantes :

(1) l'appareil ne doit pas produire de brouillage, et (2) l'utilisateur de l'appareil doit accepter tout brouillage radioélectrique subi, même si le brouillage est susceptible d'en compromettre le fonctionnement."

CAN ICES-3 (B)/NMB-3(B)



Do not dispose of in general waste.  
Please recycle batteries and damaged electrical products appropriately.



# CONTENTS

<b>1</b>	<b>ASSEMBLY</b>	<b>4</b>	<b>11</b>	<b>SOFT STOP CONFIGURATION</b>	<b>14</b>
<b>2</b>	<b>RETROFIT INSTALLATION</b>	<b>5</b>	11.1	Turn Soft Stop OFF	14
<b>3</b>	<b>CHARGING</b>	<b>5</b>	11.2	Turn Soft Stop ON	14
<b>4</b>	<b>P1 BUTTON FUNCTIONS</b>	<b>6</b>	<b>12</b>	<b>BATTERY CHECK FUNCTION</b>	<b>15</b>
4.1	Motor state test	6	12.1	Send Shade to battery charge level	15
4.2	Motor configuration options	6	<b>13</b>	<b>CHARGING LED</b>	<b>15</b>
<b>5</b>	<b>INITIAL SET UP</b>	<b>7</b>	13.1	Turn Charging LED ON/OFF	15
5.1	Pair motor with controller	7	<b>14</b>	<b>SLEEP MODE</b>	<b>16</b>
5.2	Check motor direction	7	<b>15</b>	<b>TROUBLE SHOOTING</b>	<b>16</b>
5.3	Set Limits	8			
<b>6</b>	<b>ADJUSTING LIMITS</b>	<b>9</b>			
6.1	Adjust upper limit	9			
6.2	Adjust lower limit	9			
<b>7</b>	<b>CONTROLLERS AND CHANNELS</b>	<b>10</b>			
7.1	Using <b>P2</b> Button on existing controller to add a new controller or channel	10			
7.2	Using a pre-existing controller to add or delete a controller or channel	10			
<b>8</b>	<b>FAVORITE POSITIONING</b>	<b>11</b>			
8.1	Set a favorite position	11			
8.2	Send shade to favorite position	11			
8.3	Delete favorite position	11			
<b>9</b>	<b>TILT &amp; ROLLER MODE</b>	<b>12</b>			
9.1	Toggle motor to Tilt Mode	12			
9.2	Toggle Motor to Roller Mode	12			
<b>10</b>	<b>ADJUSTING SPEED</b>	<b>13</b>			
10.1	Increase Motor Speed	13			
10.2	Decrease Motor Speed	13			

# 1 ASSEMBLY

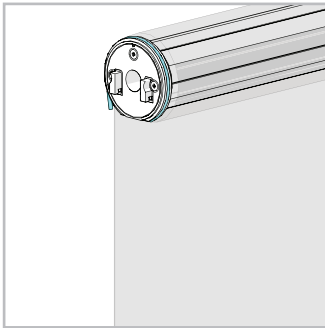
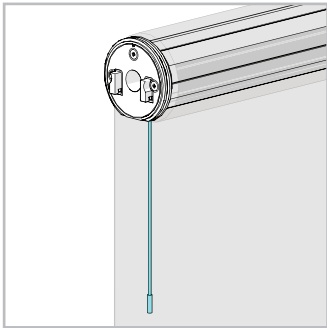
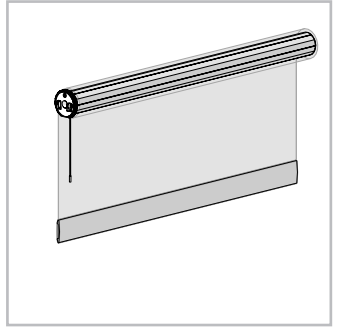
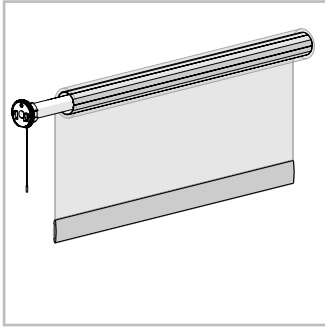
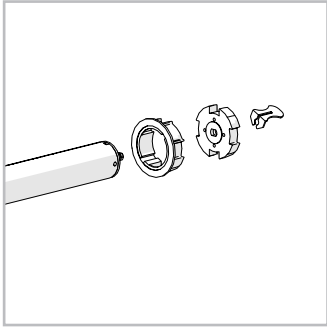
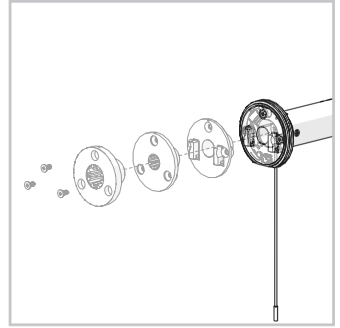
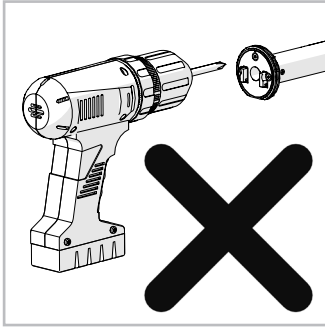
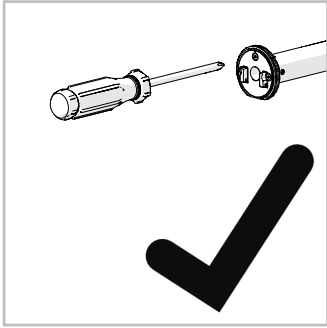

## 2 RETROFIT INSTALLATION

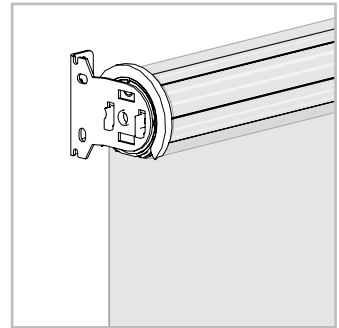
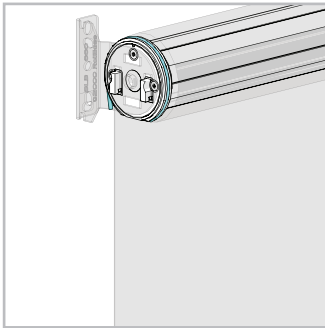
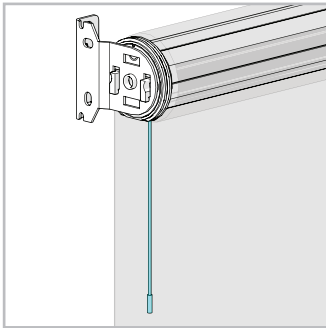
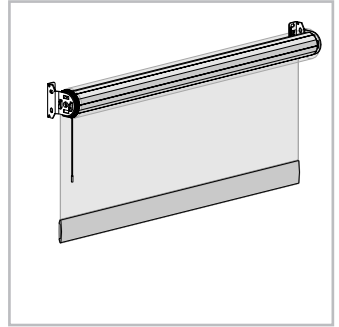
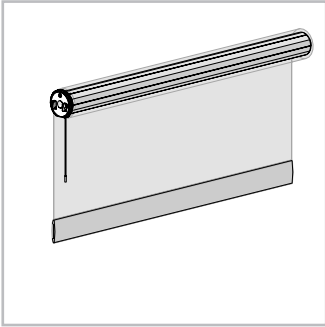
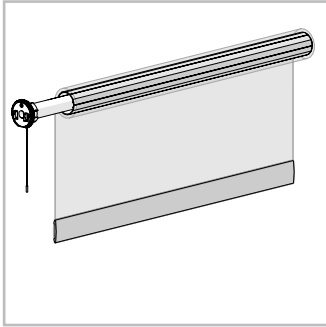
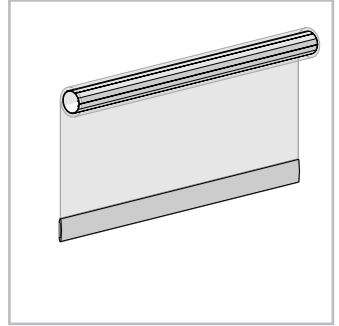
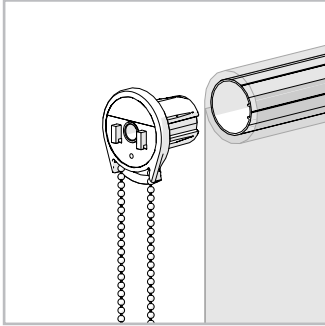
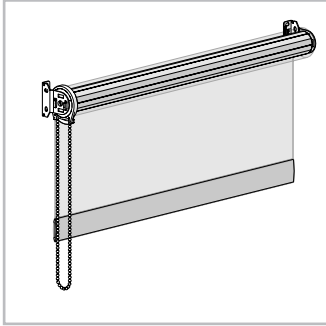

## 3 CHARGING

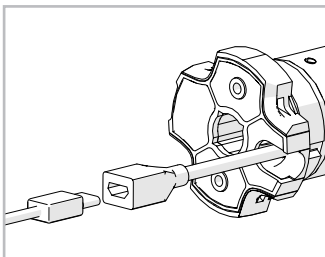
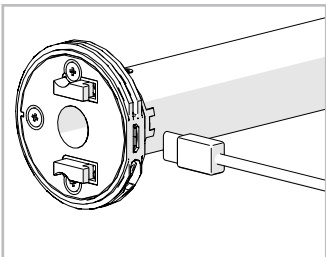

## 4 P1 BUTTON FUNCTIONS

### 4.1 Motor state test

This table describes the function of a short **P1** Button press/release (<2 seconds) depending on current motor configuration.

P1 Press	Condition	Function Achieved	Visual Feedback	Audible Feedback	Function Described
Short Press	If limit is NOT set	None	No Action	None	No Action
	If limits are set	Operational control of motor, run to limit. Stop if running	Motor Runs	None	Operational control of motor after pairing and limit setting is completed first time
	If motor is in "Sleep Mode" & limits are set	Wake and control	Motor wakes and runs in a direction	None	Motor is restored from Sleep Mode and RF control is active

### 4.2 Motor configuration options

The **P1** Button is utilized to administer motor configurations as described below.

Hold **P1** button on motor head.

#### Activate Pairing Mode



#### Sleep Mode



#### Reverse Direction



#### Reset To Factory Settings

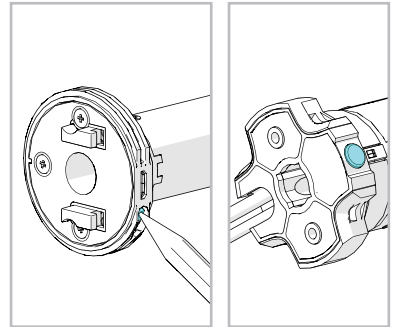

**P1** button on motor head.

## 5 INITIAL SET UP

### 5.1 Pair motor with controller

Select channel on controller.



Hold **P1** button on motor head.

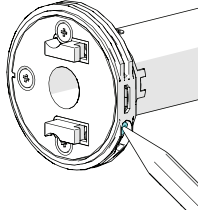

Hold **STOP** on controller.



#### **IMPORTANT**

Consult user manual for your controller for information on selecting channel.

Motor Response



Motor Response



#### **Motor is now in step mode and ready for setting limits**

### 5.2 Check motor direction

To check travel direction of shade, press **UP** or **DOWN** on controller.

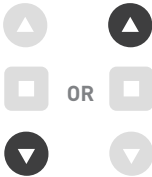

To reverse shade direction, hold both **UP** and **DOWN**.

Until the motor responds.



**Quick Press** = Step

**Long Press** = Continuous Travel

Motor Response



#### **IMPORTANT**

Damage to shade may occur when operating motor prior to setting limits. Attention should be given.

#### **IMPORTANT**

Reversing motor direction using this method is only possible during initial set-up

## 5.3 Set Limits

### **IMPORTANT**

Cycle shade up and down prior to setting limits to settle fabric

Move shade to the desired highest or lowest position by pressing the **UP** or **DOWN** buttons on controller.

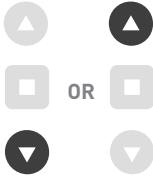

To save upper limit, hold **UP** and **STOP**.



Motor Response



Move shade to the desired highest or lowest position by pressing the **UP** or **DOWN** buttons on controller.

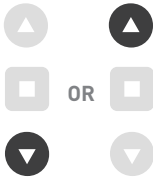

To save lower limit, hold **DOWN** and **STOP**.



Motor Response



### **IMPORTANT**

After setting limits, motor will automatically exit from initial set-up mode.



## 6 ADJUSTING LIMITS

### 6.1 Adjust upper limit

Hold **UP** and **STOP** on controller.



Move shade to the desired highest position by pressing the **UP** or **DOWN** button.

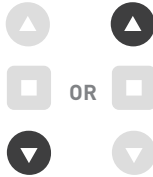

To save upper limit, hold **UP** and **STOP**.



Motor Response



Motor Response



### 6.2 Adjust lower limit

Hold **DOWN** and **STOP** on controller.



Move shade to the desired lowest position by pressing the **UP** or **DOWN** button.

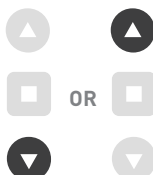

To save lower limit, hold **DOWN** and **STOP**.



Motor Response



Motor Response



#### IMPORTANT

The bottom limit should be set ~ 1.38 in. (35mm) below the Ultra-Lock to disengage the auto lock mechanism when the shade is raised.

## 7 CONTROLLERS AND CHANNELS

### 7.1 Using P2 Button on existing controller to add a new controller or channel

A = Existing controller or channel (to keep)

B = Controller or channel to add or remove

Press **P2** on controller **A**.



Press **P2** on controller **A**.

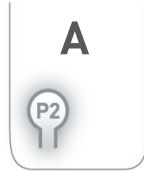

Press **STOP** on an new controller to add it.



Motor Response



Motor Response



Motor Response



**IMPORTANT** Consult user manual for your controller or sensor

### 7.2 Using a pre-existing controller to add or delete a controller or channel

A = Existing controller or channel (to keep)

B = Controller or channel to add or remove

Press **P2** on controller **A**.

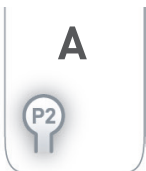

Press **P2** on controller **A**.

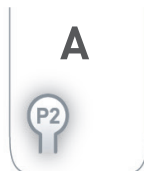

Press **P2** on the controller **B** to remove it.

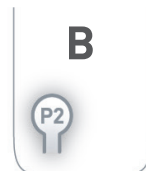

Motor Response



Motor Response



Motor Response



**IMPORTANT** Consult user manual for your controller or sensor

## 8 FAVORITE POSITIONING

### 8.1 Set a favorite position

Move shade to the desired position by pressing the **UP** or **DOWN** button on the controller.

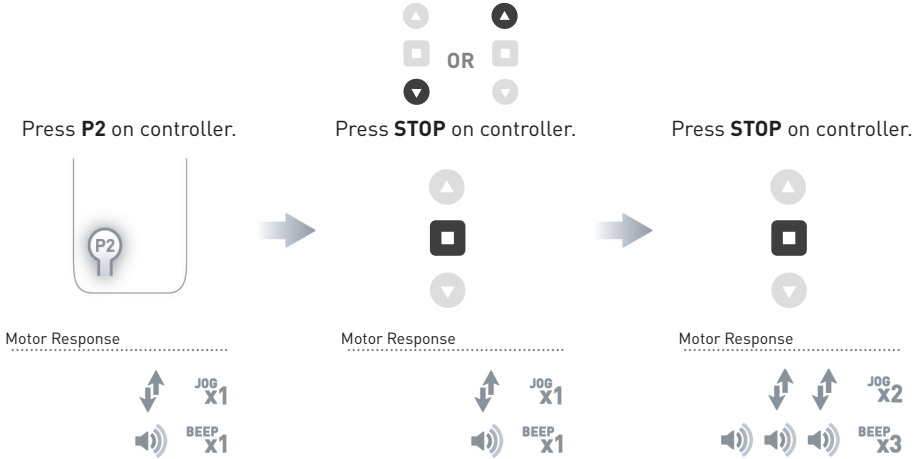

### 8.2 Send shade to favorite position



### 8.3 Delete favorite position

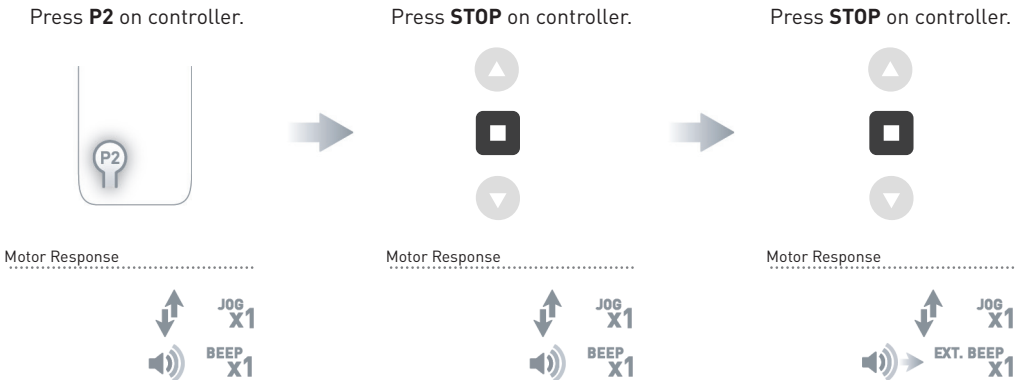

## 9 TILT & ROLLER MODE

### 9.1 Toggle motor to Tilt Mode

Default motor mode is Roller after initial Limits have been set, use following steps to change to Roller Mode.

Hold **UP & DOWN** on controller.

Press **STOP** on controller.

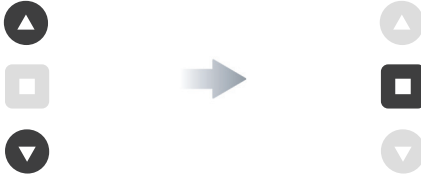

Motor Response .....

Motor Response .....



### 9.2 Toggle Motor to Roller Mode

If motor is in Tilt Mode, use following steps to change to Roller Mode.

Hold **UP & DOWN** on controller.

Press **STOP** on controller.

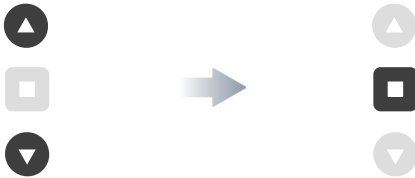

Motor Response .....

Motor Response .....



# 10 ADJUSTING SPEED

## 10.1 Increase Motor Speed

Default motor mode is the slowest speed.

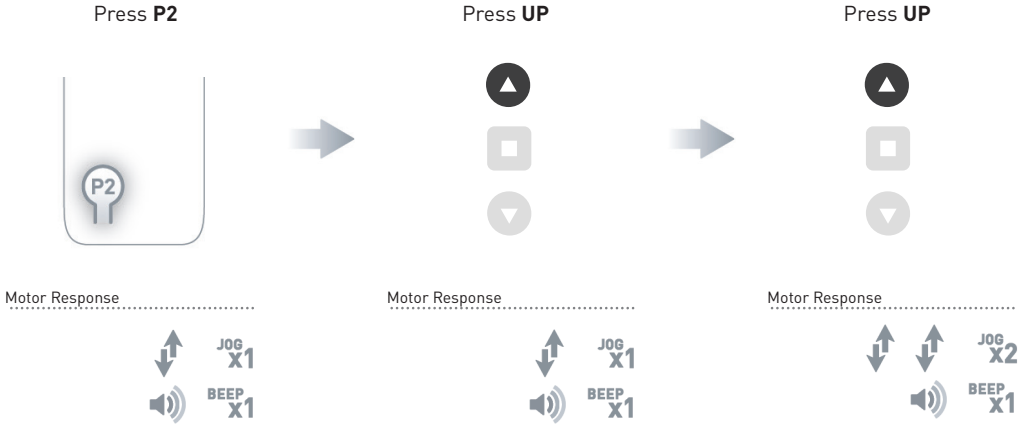

## 10.2 Decrease Motor Speed



# 11 SOFT STOP CONFIGURATION

## 11.1 Turn Soft Stop OFF

Motor must be in slowest speed to turn Soft Stop OFF.

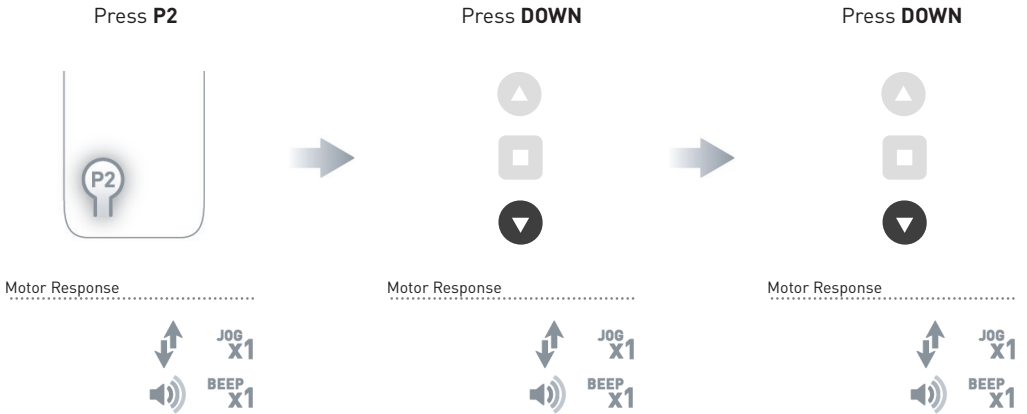

## 11.2 Turn Soft Stop ON

Motor must be in fastest speed to turn Soft Stop ON.

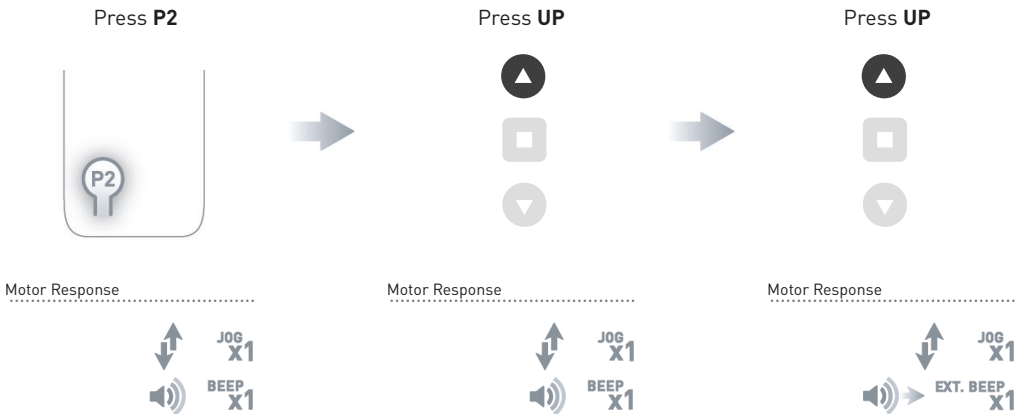

## 12 BATTERY CHECK FUNCTION

### 12.1 Send Shade to battery charge level

Shade must be at Upper Limit.

Hold **UP**



Motor Response .....

Approx. 

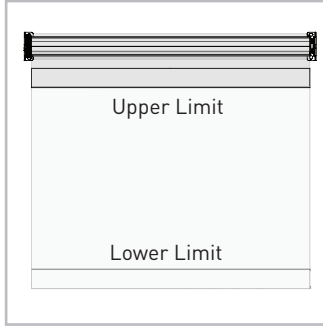

Shade must be at Upper Limit  
Hold **UP** for Approx. 5s

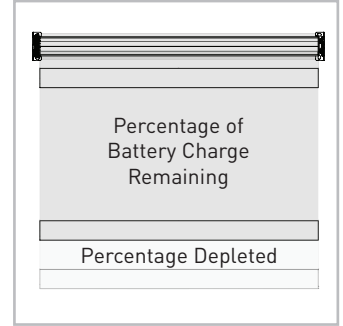

Shade moves to percentage of  
battery charge remaining

## 13 CHARGING LED

### 13.1 Turn Charging LED ON/OFF

Motor must be at Lower Limit.

Hold **DOWN** to toggle off



Motor Response .....

Approx.  Red LED flashes x3

Hold **DOWN** to toggle on



Motor Response .....

Approx.  Red LED flashes x3

## 14 SLEEP MODE

If multiple motors are grouped on a single channel, Sleep Mode may be used to put all but 1 motor to sleep, allowing programming of just the one motor that remains "Awake". See page 6 for detailed **P1** functions.

### Enter Sleep Mode

Sleep mode is utilized to prevent a motor from incorrect configuration during other motor setup.

Hold **P1** button on the motor head

Motor Response .....



### Exit Sleep Mode: Method 1

Exit sleep mode once the shade is ready.

Press and release **P1** button on the motor head

Motor Response .....



### Exit Sleep Mode: Method 2

Remove power and then re-power the motor.

## 15 TROUBLE SHOOTING

[rolleasacmeda.com](http://rolleasacmeda.com)

Problem	Cause	Remedy
Motor is not responding	Battery in motor is depleted	Recharge with a compatible charger
	Insufficient charging from solar PV panel	Check connection and orientation of PV panel
	Transmitter battery is discharged	Replace battery
	Battery is inserted incorrectly into transmitter	Check battery polarity
	Radio interference/shielding	Ensure transmitter is positioned away from metal objects and the aerial on motor or receiver is kept straight and away from metal
	Receiver distance is too far from transmitter	Move transmitter to a closer position
	Charging failure	Check power supply to motor is connected and active
Motor beeps x10 when in use	Battery voltage is low	Recharge with a compatible charger
Cannot program a single motor (multiple motors respond)	Multiple motors are paired to the same channel	Always reserve an individual channel for programming functions. Use Sleep Mode to program individual motors.

#### ROLLEASE ACMEDA | USA

Level 7 / 750 East Main Street  
Stamford, CT 06902, USA  
T +1 800 552 5100 | F +1 203 964 0513

#### ROLLEASE ACMEDA | AUSTRALIA

110 Northcorp Boulevard,  
Broadmeadows VIC 3047, AUS  
T +61 3 9355 0100 | F +61 3 9355 0110

#### ROLLEASE ACMEDA | EUROPE

Via Conca Del Naviglio 18,  
Milan (Lombardia) Italy  
T +39 02 8982 7317 | F +39 02 8982 7317