



**FCC TEST REPORT**

Report No:STS1803220W01

Issued for

Lakeshore Learning Materials

2695 E. Dominguez St., Carson, CA 90895,USA

<b>Product Name:</b>	Wireless Classroom Headphone Set, Extra Wireless Headphones
<b>Brand Name:</b>	<b>Lakeshore®</b>
<b>Model Name:</b>	DD518
<b>Series Model:</b>	N/A
<b>FCC ID:</b>	2AGG4DD518
<b>Test Standard:</b>	FCC Part 15.249

Any reproduction of this document must be done in full. No single part of this document may be reproduced without permission from STS, All Test Data Presented in this report is only applicable to presented Test sample.

Shenzhen STS Test Services Co., Ltd.  
 1/F., Building B, Zhuoke Science Park, No.190,Chongqing Road,  
 Fuyong Street, Bao'an District, Shenzhen, Guangdong,China  
 TEL: +86-755 3688 6288 FAX: +86-755 3688 6277 E-mail:sts@stsapp.com





TEST RESULT CERTIFICATION

Applicant's name : Lakeshore Learning Materials
Address : 2695 E. Dominguez St., Carson, CA 90895,USA
Manufacture's Name : Lakeshore Learning Materials
Address : 2695 E. Dominguez St., Carson, CA 90895,USA

Product description

Product Name : Wireless Classroom Headphone Set, Extra Wireless Headphones
Brand Name : Lakeshore
Model Name : DD518
Series Model : N/A
Test Standards : FCC Part15.249
Test procedure : ANSI C63.4-2014 and ANSI C63.10-2013

This device described above has been tested by STS, and the test results show that the equipment under test (EUT) is in compliance with the FCC requirements. And it is applicable only to the tested sample identified in the report.
This report shall not be reproduced except in full, without the written approval of STS, this document may be altered or revised by STS, personal only, and shall be noted in the revision of the document.

Date of Test :
Date of performance of tests : 22 Mar. 2018 ~26 Mar. 2018
Date of Issue : 30 Mar. 2018
Test Result : Pass

Testing Engineer : Chris chen
( Chris chen )

Technical Manager : Sean she
( Sean she )

Authorized Signatory : Vita Li
(Vita Li)





Table of Contents	Page
<b>1. SUMMARY OF TEST RESULTS</b>	<b>5</b>
1.1 TEST FACTORY	6
1.2 MEASUREMENT UNCERTAINTY	6
<b>2. GENERAL INFORMATION</b>	<b>7</b>
2.1 GENERAL DESCRIPTION OF EUT	7
2.2 DESCRIPTION OF TEST MODES	8
2.3 BLOCK DIGRAM SHOWING THE CONFIGURATION OF SYSTEM TESTED	9
2.4 DESCRIPTION OF SUPPORT UNITS	10
2.5 EQUIPMENTS LIST FOR ALL TEST ITEMS	11
<b>3. EMC EMISSION TEST</b>	<b>12</b>
3.1 CONDUCTED EMISSION MEASUREMENT	12
3.2 RADIATED EMISSION MEASUREMENT	16
<b>4. BANDWIDTH TEST</b>	<b>30</b>
4.1 TEST PROCEDURE	30
4.2 TEST SETUP	30
4.3 EUT OPERATION CONDITIONS	30
4.4 TEST RESULTS	30
<b>5. ANTENNA REQUIREMENT</b>	<b>32</b>
5.1 STANDARD REQUIREMENT	32
5.2 EUT ANTENNA	32
<b>APPENDIX I- PHOTOS OF TEST SETUP</b>	<b>33</b>



**Revision History**

Rev.	Issue Date	Report NO.	Effect Page	Contents
00	30 Mar. 2018	STS1803220W01	ALL	Initial Issue





## 1. SUMMARY OF TEST RESULTS

Test procedures according to the technical standards:

FCC Part 15.249,Subpart C			
Standard Section	Test Item	Judgment	Remark
15.207	Conducted Emission	Pass	
15.203	Antenna Requirement	Pass	
15.249	Radiated Emission	Pass	
15.249	20dB Bandwidth	Pass	

### NOTE:

(1) "N/A" denotes test is not applicable in this Test Report

(2) All tests are according to ANSI C63.4-2014 and ANSI C63.10-2013

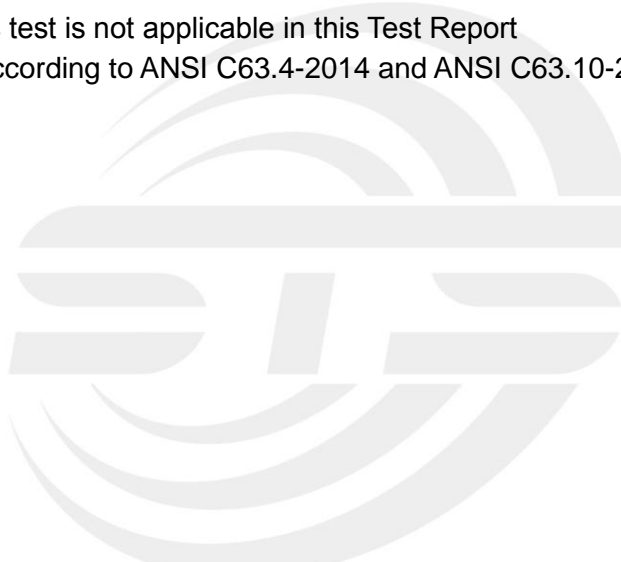



### 1.1 TEST FACTORY

Shenzhen STS Test Services Co., Ltd.

Add. : 1/F., Building B, Zhuoke Science Park, No.190, Chongqing Road,  
Fuyong Street, Bao'an District, Shenzhen, Guangdong,China

CNAS Registration No.: L7649; FCC Registration No.: 625569

IC Registration No.: 12108A; A2LA Certificate No.: 4338.01;

### 1.2 MEASUREMENT UNCERTAINTY

The reported uncertainty of measurement  $y \pm U$ , where expanded uncertainty  $U$  is based on a standard uncertainty multiplied by a coverage factor of  $k=2$ , providing a level of confidence of approximately **95 %**.

No.	Item	Uncertainty
1	Conducted Emission (9KHz-150KHz)	$\pm 2.88$ dB
2	Conducted Emission (150KHz-30MHz)	$\pm 2.67$ dB
3	RF power,conducted	$\pm 0.71$ dB
4	Spurious emissions,conducted	$\pm 0.63$ dB
5	All emissions,radiated (9KHz-30MHz)	$\pm 3.02$ dB
6	All emissions,radiated (30MHz-200MHz)	$\pm 3.80$ dB
7	All emissions,radiated (200MHz-1000MHz)	$\pm 3.97$ dB



## 2. GENERAL INFORMATION

### 2.1 GENERAL DESCRIPTION OF EUT

Product Name	Wireless Classroom Headphone Set, Extra Wireless Headphones								
Trade Name	<b>Lakeshore®</b>								
Model Name	DD518								
Series Model	N/A								
Model Difference	N/A								
Product Description	<p>The EUT is a WIRELESS CLASSROOM HEADPHONE, EXTRA WIRELESS HEADPHONES</p> <table border="1"><tr><td>Operation Frequency:</td><td>915.5, 916, 916.5MHz</td></tr><tr><td>Modulation Type:</td><td>FM</td></tr><tr><td>Antenna Designation:</td><td>PCB Antenna</td></tr><tr><td>Antenna Gain(Peak)</td><td>0 dBi</td></tr></table> <p>Based on the application, features, or specification exhibited in User's Manual, the EUT is considered as an ITE/Computing Device. More details of EUT technical specification, please refer to the User's Manual.</p>	Operation Frequency:	915.5, 916, 916.5MHz	Modulation Type:	FM	Antenna Designation:	PCB Antenna	Antenna Gain(Peak)	0 dBi
Operation Frequency:	915.5, 916, 916.5MHz								
Modulation Type:	FM								
Antenna Designation:	PCB Antenna								
Antenna Gain(Peak)	0 dBi								
Channel List	Please refer to the Note 2.								
Adapter	Input: AC120V, 9W, 60 Hz Output: DC4.5V, 200mA								
Hardware Version	N/A								
Software Version	N/A								

Note:

1. For a more detailed features description, please refer to the manufacturer's specifications or the User's Manual.



2.

Channel	Frequency (MHz)
01	915.5
02	916
03	916.5

3. Table for Filed Antenna

Ant	Brand	Model Name	Antenna Type	Connector	Gain (dBi)	NOTE
1	<b>Lakeshore®</b>	DD518(TX)	PCB	N/A	0	Antenna

The EUT antenna is spring loaded Antenna. No antenna other than that furnished by the responsible party shall be used with the device.

## 2.2 DESCRIPTION OF TEST MODES

For conducted test items and radiated spurious emissions  
Each of these EUT operation mode(s) or test configuration mode(s) mentioned below was evaluated respectively..

Worst Mode	Description	Data/Modulation
Mode 1	TX CH01	1 MHz/FM
Mode 2	TX CH02	1 MHz/FM
Mode 3	TX CH03	1 MHz/FM

Note:

- (1) All above mode have been measurement, only worst data was reported.
- (2) New Battery is used during all test.
- (3) We have be tested for all avaiable U.S. voltage and frequencies(For 120V,50/60Hz and 240V, 50/60Hz) for which the device is capable of operation, and the worst case of 120V,60Hz is shown in the report
- (4) The EUT was programmed to be in continuously transmitting mode and the transmit duty cycle is not less than 98%.



### 2.3 BLOCK DIGRAM SHOWING THE CONFIGURATION OF SYSTEM TESTED

During testing channel & power controlling software provided by the customer was used to control the operating channel as well as the output power level. The RF output power selection is for the setting of RF output power expected by the customer and is going to be fixed on the firmware of the final end product power parameters

#### Radiated Spurious Emission Test

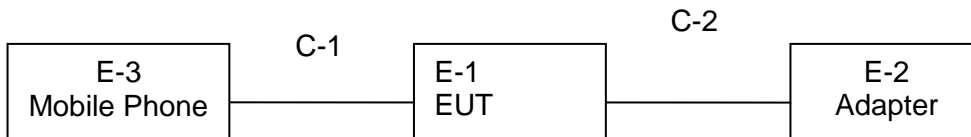

#### conduction Test Set

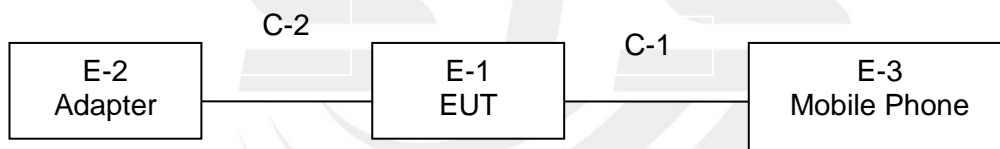



## 2.4 DESCRIPTION OF SUPPORT UNITS

The EUT has been tested as an independent unit together with other necessary accessories or support units. The following support units or accessories were used to form a representative test configuration during the tests.

Item	Equipment	Mfr/Brand	Model/Type No.	Serial No.	Note
E-2	Adapter	N/A	GPU350450200WDOO	N/A	N/A
E-3	Mobile Phone	N/A	N/A	N/A	N/A

Item	Shielded Type	Ferrite Core	Length	Note
C-1	USB Cable (FTP)	NO	100cm	N/A
C-2	AC Adapter Cable (FTP)	NO	120cm	N/A

Note:

- (1) The support equipment was authorized by Declaration of Confirmation.
- (2) For detachable type I/O cable should be specified the length in cm in 『Length』 column.



## 2.5 EQUIPMENTS LIST FOR ALL TEST ITEMS

## Radiation Test equipment

Kind of Equipment	Manufacturer	Type No.	Serial No.	Last calibration	Calibrated until
EMI Test Receiver	R&S	ESW	101535	2017.06.01	2018.05.31
Bilog Antenna	TESEQ	CBL6111D	34678	2017.11.02	2018.11.01
Horn Antenna	Schwarzbeck	BBHA 9120D(1201)	9120D-1343	2017.10.27	2018.10.26
Passive Loop (9K--30MHz)	ZHNAN	ZN3090C	16035	2018.03.11	2019.03.10
Pre-mpifier (0.1M-3GHz)	EM	EM330	60538	2018.03.11	2019.03.10
PreAmplifier	Agilent	8449B	60538	2017.10.15	2018.10.14
USB RF power sensor	DARE	RPR3006W	15I00041SNO0 3	2017.10.15	2018.10.14
Semi-anechoic chamber	Changling	966	N/A	2017.10.15	2018.10.14

## Conduction Test equipment

Kind of Equipment	Manufacturer	Type No.	Serial No.	Last calibration	Calibrated until
Test Receiver	R&S	ESCI	101427	2017.10.15	2018.10.14
LISN	R&S	ENV216	101242	2017.10.15	2018.10.14
conduction Cable	EM	C01	N/A	2018.03.11	2019.03.10
Temperature & Humidity	Mieo	HH660	N/A	2017.10.15	2018.10.14

### 3. EMC EMISSION TEST

#### 3.1 CONDUCTED EMISSION MEASUREMENT

##### 3.1.1 POWER LINE CONDUCTED EMISSION LIMITS

Operating frequency band. In case the emission fall within the restricted band specified on Part 15.249 limit in the table below has to be followed.

FREQUENCY (MHz)	Quasi-peak	Average
0.15 -0.5	66 - 56 *	56 - 46 *
0.50 -5.0	56.00	46.00
5.0 -30.0	60.00	50.00

Note:

- (1) The tighter limit applies at the band edges.
- (2) The limit of " \* " marked band means the limitation decreases linearly with the logarithm of the frequency in the range.

The following table is the setting of the receiver

Receiver Parameters	Setting
Attenuation	10 dB
Start Frequency	0.15 MHz
Stop Frequency	30 MHz
IF Bandwidth	9 kHz

3.1.2 TEST PROCEDURE

- a. The EUT was 0.8 meters from the horizontal ground plane and 0.4 meters from the vertical ground plane with EUT being connected to the power mains through a line impedance stabilization network (LISN). All other support equipments powered from additional LISN(s). The LISN provide 50 Ohm/ 50uH of coupling impedance for the measuring instrument.
- b. Interconnecting cables that hang closer than 40 cm to the ground plane shall be folded back and forth in the center forming a bundle 30 to 40 cm long.
- c. I/O cables that are not connected to a peripheral shall be bundled in the center. The end of the cable may be terminated, if required, using the correct terminating impedance. The overall length shall not exceed 1 m.
- d. LISN at least 80 cm from nearest part of EUT chassis.
- e. For the actual test configuration, please refer to the related Item –EUT Test Photos.

3.1.3 TEST SETUP

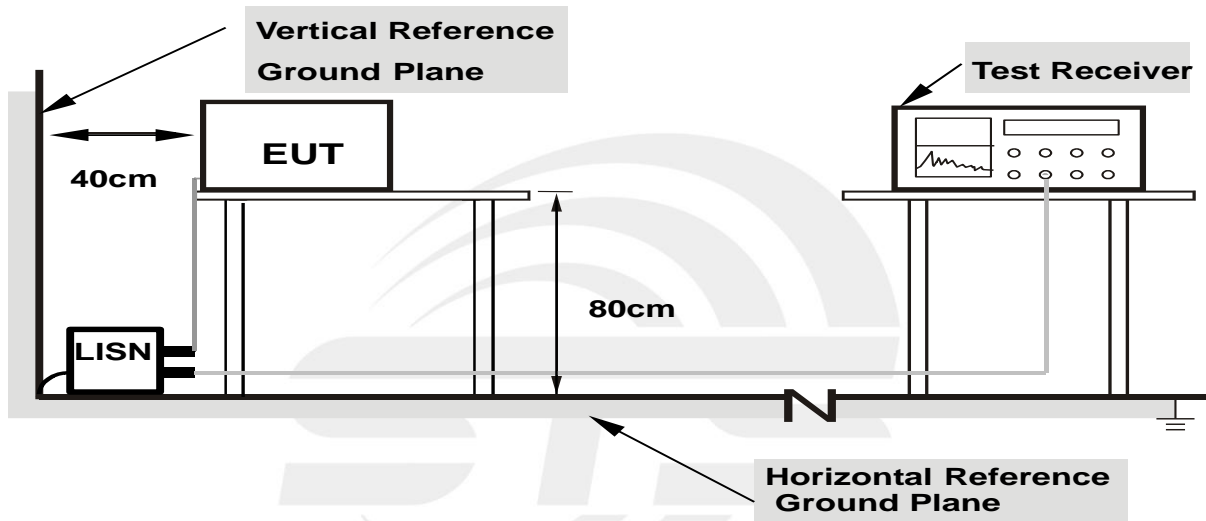

- Note: 1.Support units were connected to second LISN.**  
**2.Both of LISNs (AMN) are 80 cm from EUT and at least 80 from other units and other metal planes**

3.1.4 EUT OPERATING CONDITIONS

The EUT was configured for testing in a typical fashion (as a customer would normally use it). The EUT has been programmed to continuously transmit during test. This operating condition was tested and used to collect the included data.



3.1.5 TEST RESULTS

Temperature:	23.5 °C	Relative Humidity:	59%
Test Voltage:	AC 120V/60Hz	Phase:	L
Test Mode:	Mode 1		

Frequency (MHz)	Reading (dBuV)	Correct Factor(dB)	Result (dBuV)	Limit (dBuV)	Margin (dB)	Remark
0.1700	45.15	9.79	54.94	64.96	-10.02	QP
0.1700	26.42	9.79	36.21	54.96	-18.75	AVG
0.3660	41.96	10.10	52.06	58.59	-6.53	QP
0.3660	30.11	10.10	40.21	48.59	-8.38	AVG
0.6180	39.38	9.92	49.30	56.00	-6.70	QP
0.6180	27.36	9.92	37.28	46.00	-8.72	AVG
1.1260	37.64	9.80	47.44	56.00	-8.56	QP
1.1260	18.21	9.80	28.01	46.00	-17.99	AVG
2.4180	36.61	9.80	46.41	56.00	-9.59	QP
2.4180	26.96	9.80	36.76	46.00	-9.24	AVG
13.5660	29.23	10.22	39.45	60.00	-20.55	QP
13.5660	16.67	10.22	26.89	50.00	-23.11	AVG

Remark:

1. Margin = Result (Result =Reading + Factor )–Limit  
 100.0 dBuV

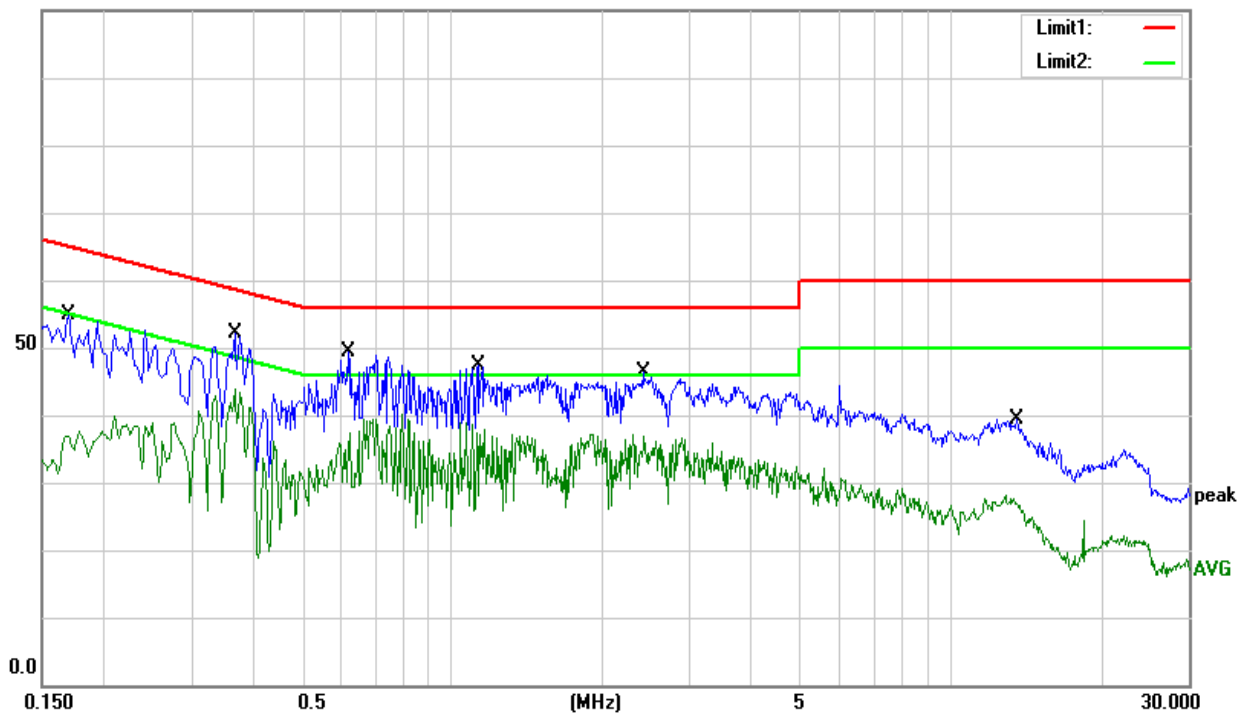



Temperature:	23.5 °C	Relative Humidity:	59%
Test Voltage:	AC 120V/60Hz	Phase:	N
Test Mode:	Mode 1		

Frequency (MHz)	Reading (dBUV)	Correct Factor(dB)	Result (dBUV)	Limit (dBUV)	Margin (dB)	Remark
0.1660	38.23	9.79	48.02	65.16	-17.14	QP
0.1660	17.98	9.79	27.77	55.16	-27.39	AVG
0.3780	37.26	10.11	47.37	58.32	-10.95	QP
0.3780	31.90	10.11	42.01	48.32	-6.31	AVG
0.8620	34.41	9.83	44.24	56.00	-11.76	QP
0.8620	20.85	9.83	30.68	46.00	-15.32	AVG
2.9140	34.42	9.91	44.33	56.00	-11.67	QP
2.9140	19.69	9.91	29.60	46.00	-16.40	AVG
6.2420	32.93	9.90	42.83	60.00	-17.17	QP
6.2420	19.40	9.90	29.30	50.00	-20.70	AVG
11.8740	27.56	9.98	37.54	60.00	-22.46	QP
11.8740	9.53	9.98	19.51	50.00	-30.49	AVG

Remark:

1. Margin = Result (Result = Reading + Factor ) – Limit  
 100.0 dBUV

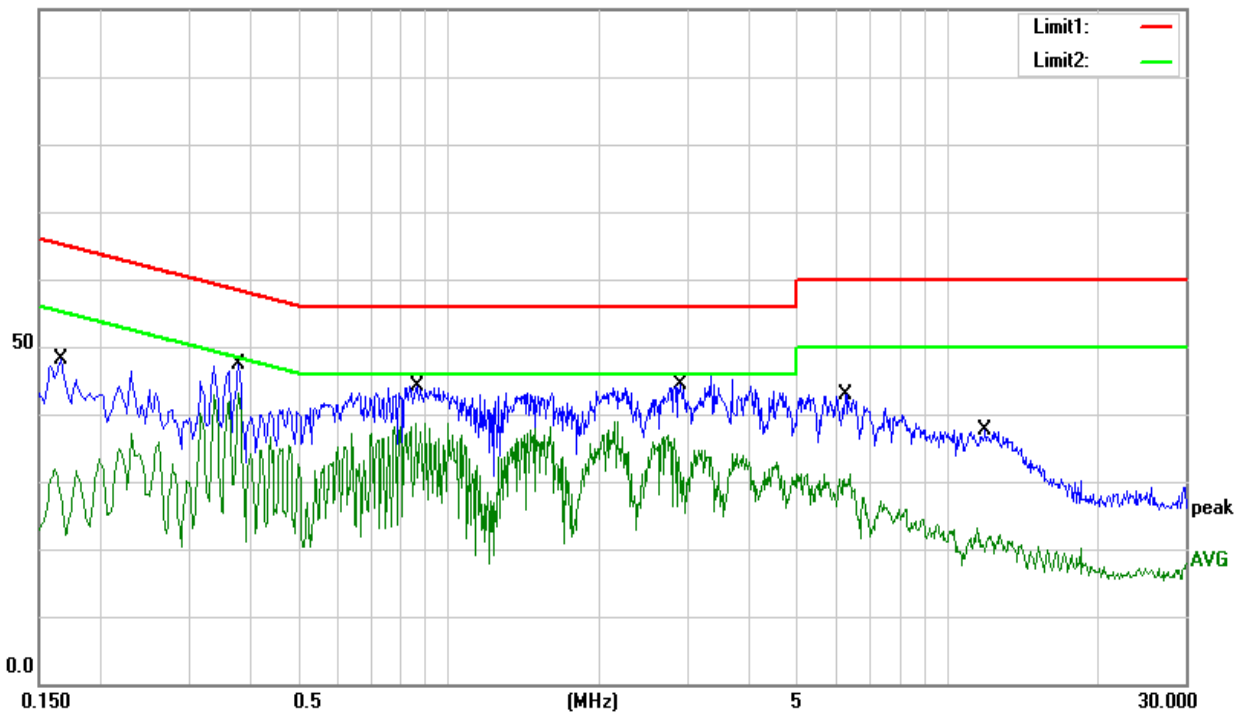

Note: 915.5MHz, 916MHz, 916.5MHz have been test, only show the worst data.



3.2 RADIATED EMISSION MEASUREMENT

3.2.1 RADIATED EMISSION LIMITS

20dBc in any 100 kHz bandwidth outside the operating frequency band. In case the emission fall within the restricted band specified on Part 15.205(a), then the Part 15.209(a) and Part 15.231(b) limit in the table below has to be followed.

LIMITS OF RADIATED EMISSION MEASUREMENT (0.009MHz - 1000MHz)

Frequencies (MHz)	Field Strength (micovolts/meter)	Measurement Distance (meters)
0.009~0.490	2400/F(KHz)	300
0.490~1.705	24000/F(KHz)	30
1.705~30.0	30	30
30~40.66	100	3
40.70~70	100	3

LIMITS OF RADIATED EMISSION MEASUREMENT ( FCC 15.249)

Frequency of Emission (MHz)	Field Strength of fundamental ((millivolts /meter)	Field Strength of Harmonics (microvolts/meter)
902-928	50	500

Notes:

- (1) Emissions radiated outside of the specified frequency bands, except for harmonics, shall be attenuated by at least 50 dB below the level of the fundamental or to the general radiated emission limits in Section 15.209, whichever is the lesser attenuation.

Spectrum Parameter	Setting
Detector	Peak
Attenuation	Auto
Start Frequency	1000 MHz
Stop Frequency	10th carrier harmonic
RBW / VBW (emission in restricted band)	RBW=1MHz,VBW=3xRBW

Receiver Parameter	Setting
Start ~ Stop Frequency	9kHz~90kHz / RB 200Hz for PK-AV
	90kHz~110kHz / RB 200Hz for QP
	110kHz~490KHz / RB 9kHz for PK-AV
	490kHz~30MHz / RB 9kHz for QP
	30MHz~1000MHz / RB 100kHz for QP-PK





### 3.2.2 TEST PROCEDURE

- a. The measuring distance of at 3 m shall be used for measurements at frequency up to 1GHz. For frequencies above 1GHz, any suitable measuring distance may be used.
- b. The EUT was placed on the top of a rotating table 0.8 meters above the ground at a 3 meter open area test site. The table was rotated 360 degrees to determine the position of the highest radiation.
- c. The height of the equipment or of the substitution antenna shall be 0.8 m; the height of the test antenna shall vary between 1 m to 4 m. Both horizontal and vertical polarizations of the antenna are set to make the measurement.
- d. The initial step in collecting conducted emission data is a spectrum analyzer peak detector mode pre-scanning the measurement frequency range. Significant peaks are then marked and then Quasi Peak detector mode re-measured.
- e. If the Peak Mode measured value compliance with and lower than Quasi Peak Mode Limit,
- f. For the actual test configuration, please refer to the related Item –EUT Test Photos.

Note:

Both horizontal and vertical antenna polarities were tested and performed pretest to three orthogonal axis. The worst case emissions were reported

### 3.2.3 DEVIATION FROM TEST STANDARD

No deviation



### 3.2.4 TEST SETUP

(A) Radiated Emission Test-Up Frequency Below 30MHz

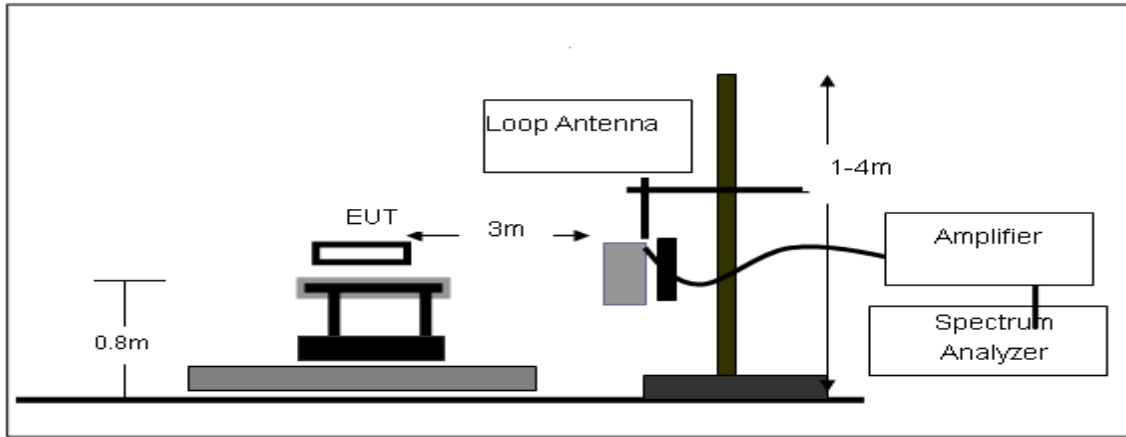

(B) Radiated Emission Test-Up Frequency 30MHz~1GHz

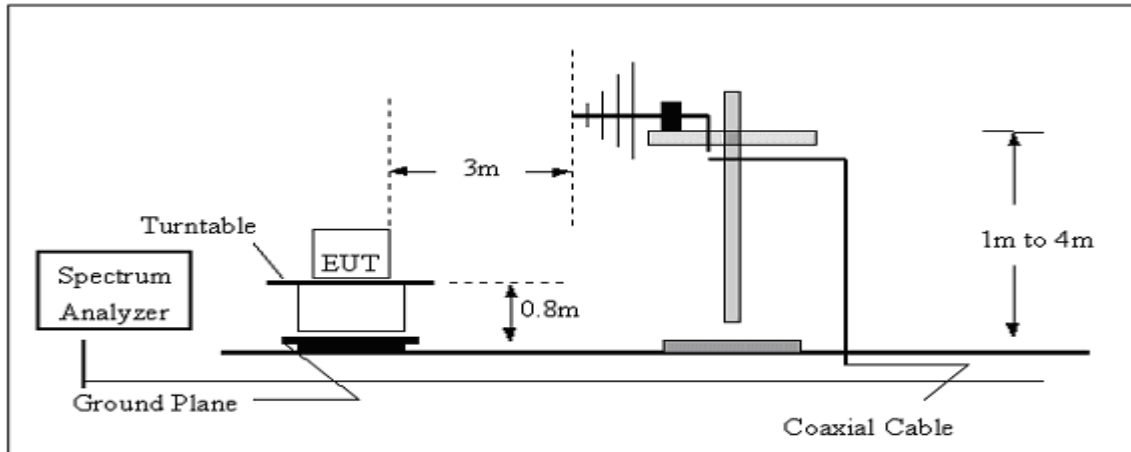

(C) Radiated Emission Test-Up Frequency Above 1GHz

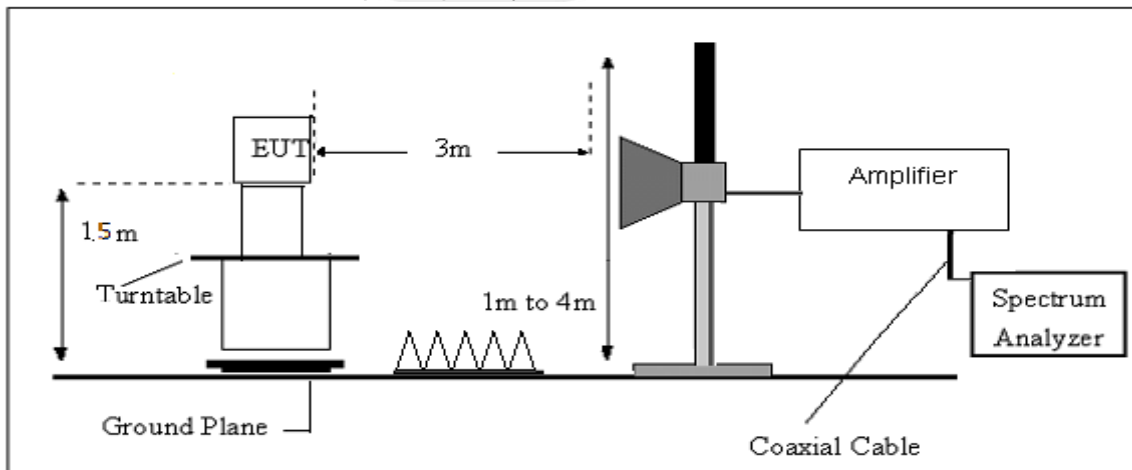



### 3.2.5 FIELD STRENGTH CALCULATION

The field strength is calculated by adding the Antenna Factor and Cable Factor and subtracting the Amplifier Gain and Duty Cycle Correction Factor (if any) from the measured reading. The basic equation with a sample calculation is as follows:

$$FS = RA + AF + CL - AG$$

Where

FS = Field Strength

CL = Cable Attenuation Factor (Cable Loss)

RA = Reading Amplitude

AG = Amplifier Gain

AF = Antenna Factor

For example

Frequency (MHz)	FS (dB $\mu$ V/m)	RA (dB $\mu$ V/m)	AF (dB)	CL (dB)	AG (dB)	Factor (dB)
300	40	58.1	12.2	1.6	31.9	-18.1

$$\text{Factor} = \text{AF} + \text{CL} - \text{AG}$$





### 3.2.6 EUT OPERATING CONDITIONS

The EUT tested system was configured as the statements of 2.4 Unless otherwise a special operating condition is specified in the follows during the testing.

Below 30 MHz

Temperature:	23.5 °C	Relative Humidity:	59%
Test Voltage:	AC 120V/60Hz	Polarization:	---
Test Mode:	TX Mode		

Freq.	Reading	Limit	Margin	State
(MHz)	(dBuV/m)	(dBuV/m)	(dB)	P/F
--	--	--	--	PASS
--	--	--	--	PASS

**NOTE:**

The amplitude of spurious emissions which are attenuated by more than 20dB below the permissible value has no need to be reported.

Distance extrapolation factor =  $40 \log(\text{specific distance}/\text{test distance})$ (dB);

Limit line = specific limits(dBuV) + distance extrapolation factor.



Between 30MHz – 1000 MHz Radiation Spurious

Temperature:	22.1 °C	Relative Humidity:	56%
Test Voltage:	AC 120V/60Hz	Phase:	Horizontal
Test Mode:	Model 1		

Frequency (MHz)	Reading (dBuV)	Correct Factor(dB/m)	Result (dBuV/m)	Limit (dBuV/m)	Margin (dB)	Remark
49.5328	53.80	-21.24	32.56	40.00	-7.44	QP
92.4624	56.83	-19.95	36.88	43.50	-6.62	QP
256.5210	50.45	-15.50	34.95	46.00	-11.05	QP
902.0000	28.19	-2.20	25.99	46.00	-20.01	QP
915.5000	82.61	-1.73	80.88	94.00	-13.12	Peak
928.0000	26.66	-1.23	25.43	46.00	-20.57	QP

Remark:

1. Margin = Result (Result =Reading + Factor )–Limit

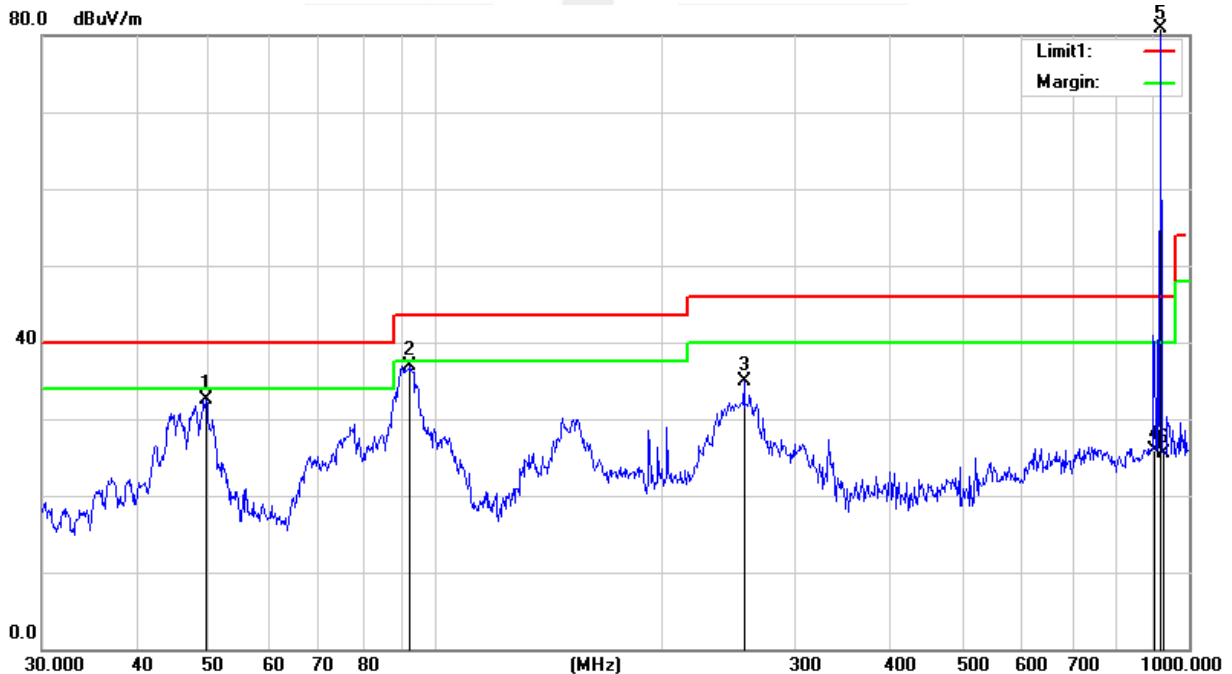



Temperature:	22.1 °C	Relative Humidity:	56%
Test Voltage:	AC 120V/60Hz	Phase:	Vertical
Test Mode:	Model 1		

Frequency (MHz)	Reading (dBuV)	Correct Factor(dB/m)	Result (dBuV/m)	Limit (dBuV/m)	Margin (dB)	Remark
47.4917	53.27	-20.19	33.08	40.00	-6.92	QP
76.2442	52.59	-23.22	29.37	40.00	-10.63	QP
154.2786	53.83	-18.20	35.63	43.50	-7.87	QP
902.0000	30.14	-2.20	27.94	46.00	-18.06	QP
915.5000	83.40	-1.73	81.67	94.00	-12.33	Peak
928.0000	28.49	-1.23	27.26	46.00	-18.74	QP

Remark:

1. Margin = Result (Result =Reading + Factor )–Limit

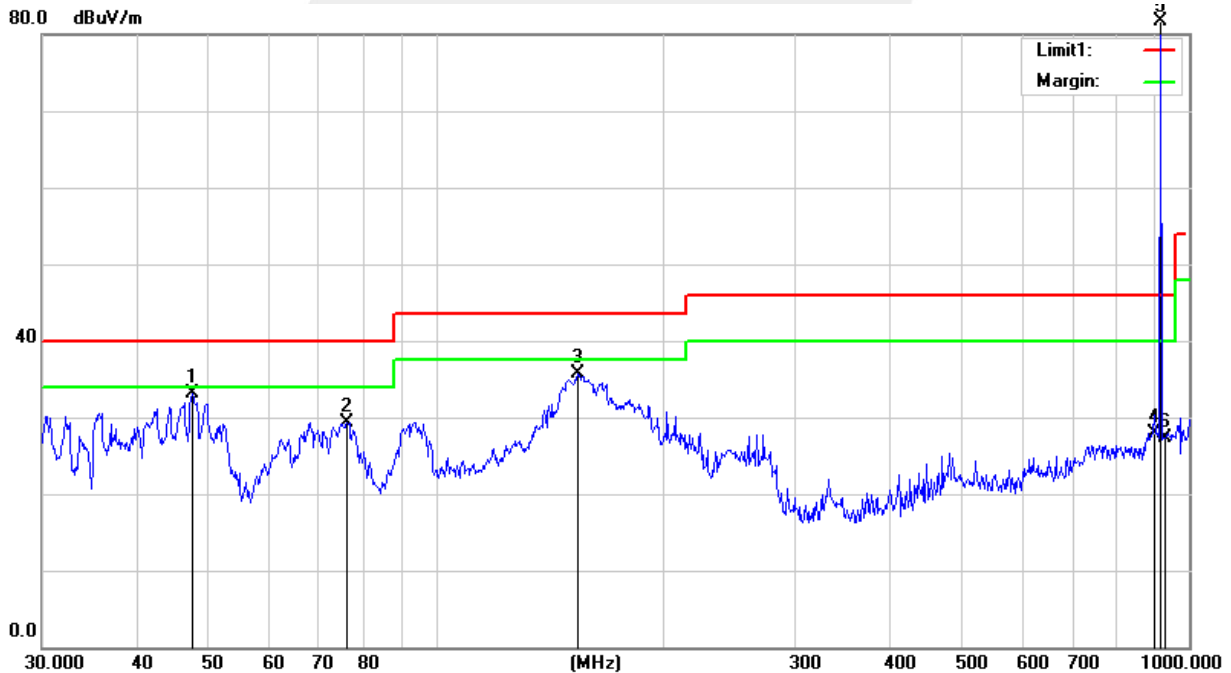

Note: The frequency 915.5MHz AV Limit is 94 dBuV/m , the peak value is less than the AV limit, so there is no need to evaluate the AV limits.



Temperature:	22.1 °C	Relative Humidity:	56%
Test Voltage:	AC 120V/60Hz	Phase:	Horizontal
Test Mode:	Model 2		

Frequency (MHz)	Reading (dBuV)	Correct Factor(dB/m)	Result (dBuV/m)	Limit (dBuV/m)	Margin (dB)	Remark
44.2751	43.59	-18.53	25.06	40.00	-14.94	QP
95.0930	50.39	-19.68	30.71	43.50	-12.79	QP
234.9910	48.96	-18.12	30.84	46.00	-15.16	QP
902.0000	27.17	-2.20	24.97	46.00	-21.03	QP
916.0000	79.47	-1.71	77.76	94.00	-16.24	Peak
928.0000	26.14	-1.23	24.91	46.00	-21.09	QP

Remark:

1. Margin = Result (Result =Reading + Factor )–Limit

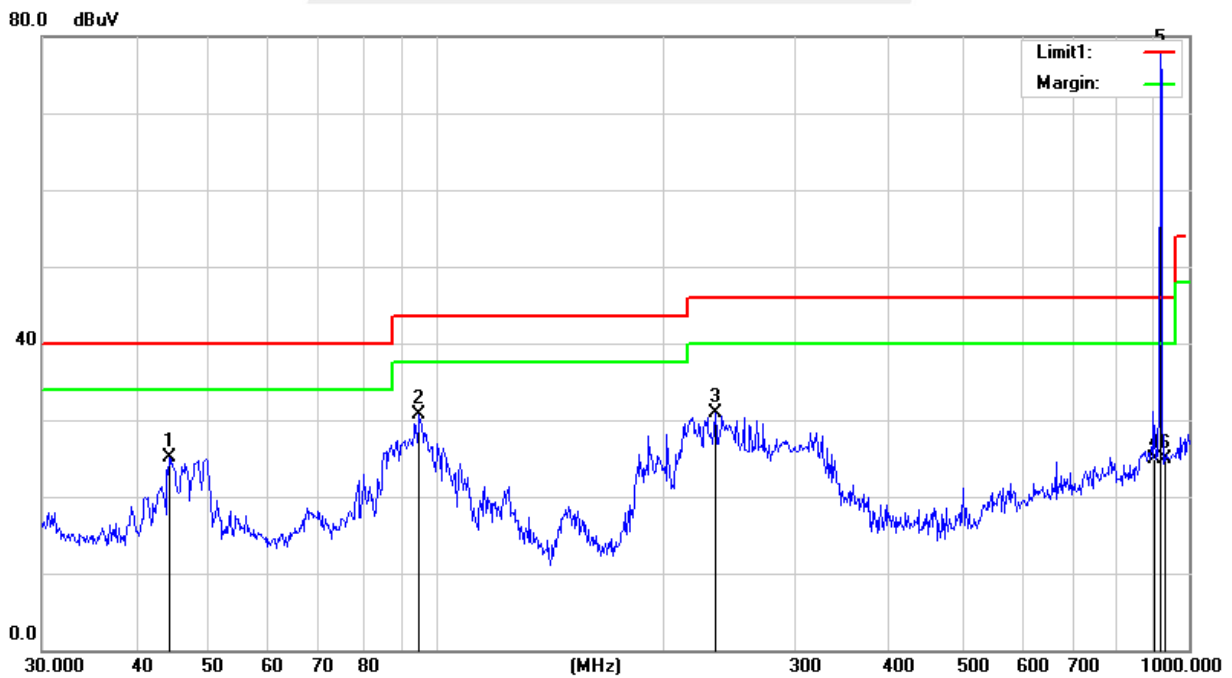



Temperature:	22.1 °C	Relative Humidity:	56%
Test Voltage:	AC 120V/60Hz	Phase:	Vertical
Test Mode:	Model 2		

Frequency (MHz)	Reading (dBuV)	Correct Factor(dB/m)	Result (dBuV/m)	Limit (dBuV/m)	Margin (dB)	Remark
49.0144	56.44	-20.97	35.47	40.00	-4.53	QP
148.9625	53.32	-17.92	35.40	43.50	-8.10	QP
260.1444	40.09	-15.07	25.02	46.00	-20.98	QP
902.0000	26.06	-2.20	23.86	46.00	-22.14	QP
916.0000	81.13	-1.71	79.42	94.00	-14.58	Peak
928.0000	26.33	-1.23	25.10	46.00	-20.90	QP

Remark:

1. Margin = Result (Result =Reading + Factor )–Limit

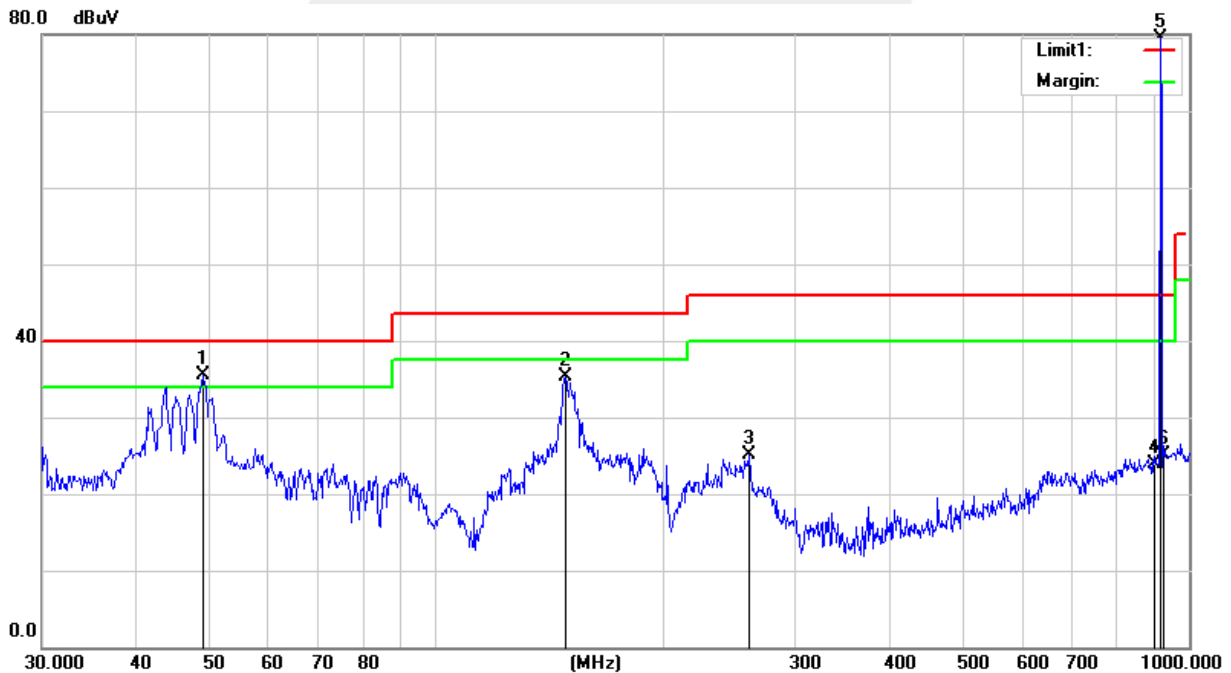

Note: The frequency 916MHz AV Limit is 94 dBuV/m , the peak value is less than the AV limit, so there is no need to evaluate the AV limits.





Temperature:	22.1 °C	Relative Humidity:	56%
Test Voltage:	AC 120V/60Hz	Phase:	Horizontal
Test Mode:	Model 3		

Frequency (MHz)	Reading (dBuV)	Correct Factor(dB/m)	Result (dBuV/m)	Limit (dBuV/m)	Margin (dB)	Remark
49.5328	56.11	-21.24	34.87	40.00	-5.13	QP
95.4270	48.55	-19.65	28.90	43.50	-14.60	QP
229.2931	49.36	-18.52	30.84	46.00	-15.16	QP
902.0000	27.17	-2.20	24.97	46.00	-21.03	QP
916.5000	78.46	-1.70	76.76	94.00	-17.24	Peak
928.0000	26.14	-1.23	24.91	46.00	-21.09	QP

Remark:

1. Margin = Result (Result =Reading + Factor )–Limit

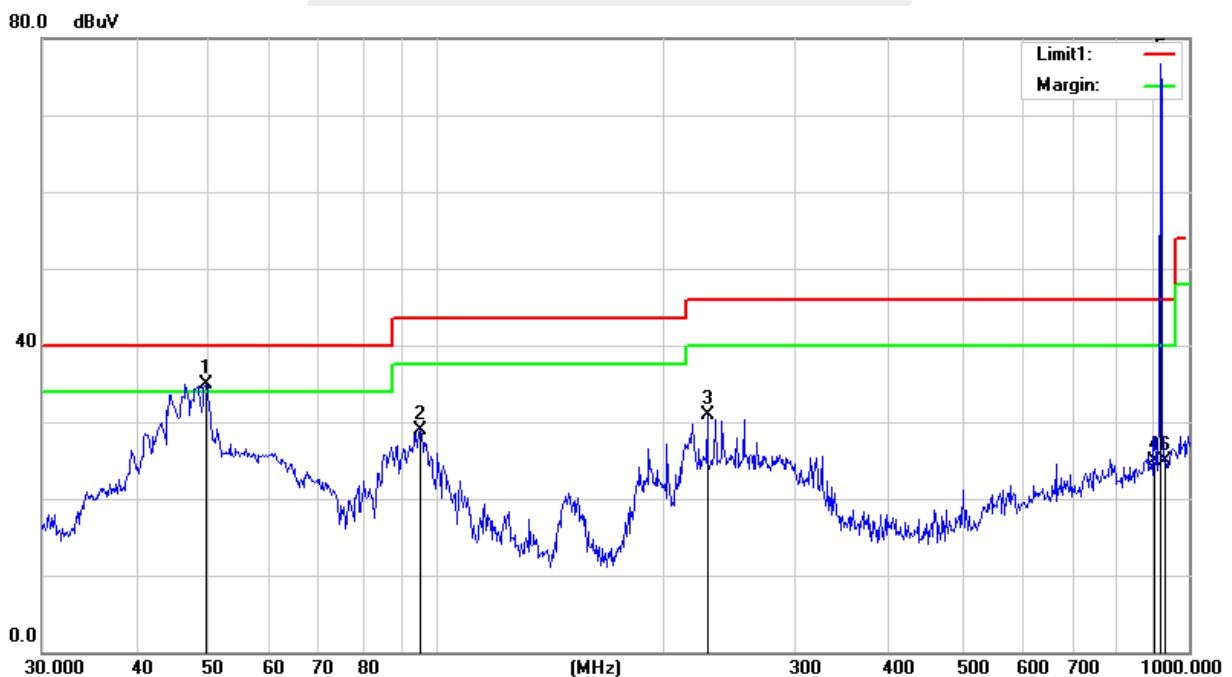



Temperature:	22.1 °C	Relative Humidity:	56%
Test Voltage:	AC 120V/60Hz	Phase:	Vertical
Test Mode:	Model 3		

Frequency (MHz)	Reading (dBuV)	Correct Factor(dB/m)	Result (dBuV/m)	Limit (dBuV/m)	Margin (dB)	Remark
49.0144	57.44	-20.97	36.47	40.00	-3.53	QP
148.9625	54.32	-17.92	36.40	43.50	-7.10	QP
229.2931	46.34	-18.52	27.82	46.00	-18.18	QP
902.0000	27.56	-2.20	25.36	46.00	-20.64	QP
916.5000	83.12	-1.70	81.42	94.00	-12.58	Peak
928.0000	26.33	-1.23	25.10	46.00	-20.90	QP

Remark:

1. Margin = Result (Result =Reading + Factor )–Limit

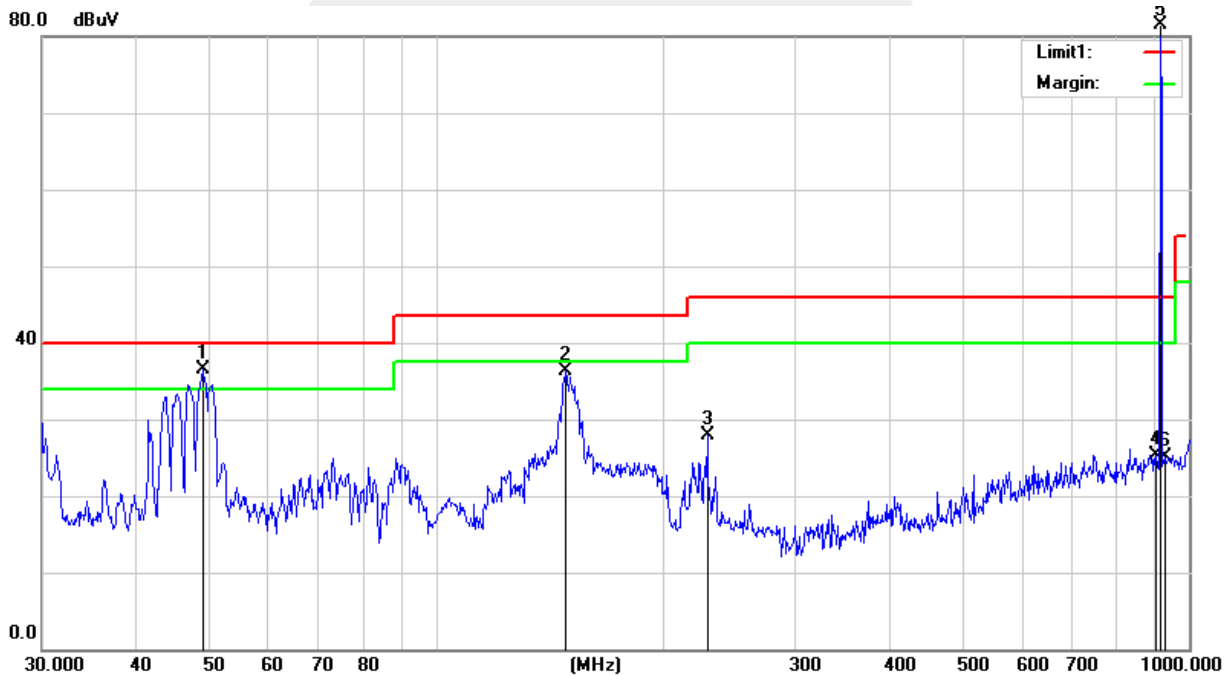

Note: The frequency 916.5MHz AV Limit is 94 dBuV/m , the peak value is less than the AV limit, so there is no need to evaluate the AV limits.



Above 1G Radiation Spurious

Frequency (MHz)	Reading (dBμV)	Amplifier (dB)	Loss (dB)	Antenna Factor (dB/m)	Corrected Factor (dB)	Emission Level (dBμV/m)	Limits (dBμV/m)	Margin (dB)	Detector Type	Comment
Low Channel (915.5 MHz)										
1099.60	68.06	46.30	3.70	24.30	-18.30	49.76	74	-24.24	PK	Horizontal
1099.60	49.54	46.30	3.70	24.30	-18.30	31.24	54	-22.76	AV	Horizontal
1099.89	68.10	46.30	3.70	24.30	-18.30	49.80	74	-24.20	PK	Vertical
1099.89	50.21	46.30	3.70	24.30	-18.30	31.91	54	-22.09	AV	Vertical
1831.52	79.67	44.10	5.30	25.00	-13.80	65.87	74	-8.13	PK	Horizontal
1831.52	61.66	44.10	5.30	25.00	-13.80	47.86	54	-6.14	AV	Horizontal
1831.32	78.92	44.10	5.30	25.00	-13.80	65.12	74	-8.88	PK	Vertical
1831.32	61.55	44.10	5.30	25.00	-13.80	47.75	54	-6.25	AV	Vertical
2746.58	74.24	44.40	6.20	27.60	-10.60	63.64	74	-10.36	PK	Horizontal
2746.58	54.67	44.40	6.20	27.60	-10.60	44.07	54	-9.93	AV	Horizontal
2746.62	72.82	44.40	6.20	27.60	-10.60	62.22	74	-11.78	PK	Vertical
2746.62	53.43	44.40	6.20	27.60	-10.60	42.83	54	-11.17	AV	Vertical
3662.59	65.26	44.20	7.90	29.70	-6.60	58.66	74	-15.34	PK	Horizontal
3662.59	48.23	44.20	7.90	29.70	-6.60	41.63	54	-12.37	AV	Horizontal
3662.88	67.76	44.20	7.90	29.70	-6.60	61.16	74	-12.84	PK	Vertical
3662.88	49.14	44.20	7.90	29.70	-6.60	42.54	54	-11.46	AV	Vertical



Frequency (MHz)	Reading (dBμV)	Amplifier (dB)	Loss (dB)	Antenna	Corrected	Emission	Limits (dBμV/m)	Margin (dB)	Detector	Comment
				Factor (dB/m)	Factor (dB)	Level (dBμV/m)			Type	
Mid Channel (916 MHz)										
1099.75	67.11	46.30	3.70	24.30	-18.30	48.81	74	-25.19	PK	Vertical
1099.75	49.15	46.30	3.70	24.30	-18.30	30.85	54	-23.15	AV	Vertical
1100.20	68.35	46.30	3.70	24.30	-18.30	50.05	74	-23.95	PK	Horizontal
1100.20	49.88	46.30	3.70	24.30	-18.30	31.58	54	-22.42	AV	Horizontal
1832.44	79.35	44.10	5.30	25.00	-13.80	65.55	74	-8.45	PK	Vertical
1832.44	61.53	44.10	5.30	25.00	-13.80	47.73	54	-6.27	AV	Vertical
1832.75	78.87	44.10	5.30	25.00	-13.80	65.07	74	-8.93	PK	Horizontal
1832.75	60.73	44.10	5.30	25.00	-13.80	46.93	54	-7.07	AV	Horizontal
2748.66	74.71	44.40	6.20	27.60	-10.60	64.11	74	-9.89	PK	Vertical
2748.66	53.97	44.40	6.20	27.60	-10.60	43.37	54	-10.63	AV	Vertical
2748.94	73.62	44.40	6.20	27.60	-10.60	63.02	74	-10.98	PK	Horizontal
2748.94	54.10	44.40	6.20	27.60	-10.60	43.50	54	-10.50	AV	Horizontal
3664.89	64.68	44.20	7.90	29.70	-6.60	58.08	74	-15.92	PK	Vertical
3664.89	48.56	44.20	7.90	29.70	-6.60	41.96	54	-12.04	AV	Vertical
3664.95	67.12	44.20	7.90	29.70	-6.60	60.52	74	-13.48	PK	Horizontal
3664.95	48.10	44.20	7.90	29.70	-6.60	41.50	54	-12.50	AV	Horizontal



Frequency (MHz)	Reading (dBμV)	Amplifier (dB)	Loss (dB)	Antenna	Corrected	Emission	Limits (dBμV/m)	Margin (dB)	Detector	Comment
				Factor (dB/m)	Factor (dB)	Level (dBμV/m)			Type	
High Channel (916.5 MHz)										
1099.89	67.32	46.30	3.70	24.30	-18.30	49.02	74	-24.98	PK	Horizontal
1099.89	49.80	46.30	3.70	24.30	-18.30	31.50	54	-22.50	AV	Horizontal
1100.33	67.49	46.30	3.70	24.30	-18.30	49.19	74	-24.81	PK	Vertical
1100.33	50.25	46.30	3.70	24.30	-18.30	31.95	54	-22.05	AV	Vertical
1833.56	79.91	44.10	5.30	25.00	-13.80	66.11	74	-7.89	PK	Horizontal
1833.56	61.03	44.10	5.30	25.00	-13.80	47.23	54	-6.77	AV	Horizontal
1833.89	80.24	44.10	5.30	25.00	-13.80	66.44	74	-7.56	PK	Vertical
1833.89	60.76	44.10	5.30	25.00	-13.80	46.96	54	-7.04	AV	Vertical
2749.56	73.49	44.40	6.20	27.60	-10.60	62.89	74	-11.11	PK	Horizontal
2749.56	54.41	44.40	6.20	27.60	-10.60	43.81	54	-10.19	AV	Horizontal
2749.99	72.80	44.40	6.20	27.60	-10.60	62.20	74	-11.80	PK	Vertical
2749.99	54.01	44.40	6.20	27.60	-10.60	43.41	54	-10.59	AV	Vertical
3666.88	64.87	44.20	7.90	29.70	-6.60	58.27	74	-15.73	PK	Horizontal
3666.88	48.36	44.20	7.90	29.70	-6.60	41.76	54	-12.24	AV	Horizontal
3666.92	67.26	44.20	7.90	29.70	-6.60	60.66	74	-13.34	PK	Vertical
3666.92	48.45	44.20	7.90	29.70	-6.60	41.85	54	-12.15	AV	Vertical

#### 4. BANDWIDTH TEST

##### 4.1 TEST PROCEDURE

- a. The EUT was directly connected to the spectrum analyzer and antenna output port as show in the block diagram below,
- b. Spectrum Setting : RBW= 100KHz, VBW $\geq$ RBW, Sweep time = Auto.

##### 4.2 TEST SETUP



##### 4.3 EUT OPERATION CONDITIONS

TX mode.

##### 4.4 TEST RESULTS

Temperature:	25 °C	Relative Humidity:	50%
Test Voltage:	AC 120V/60Hz		
Test Channel	Frequency (MHz)	20 dB Bandwidth (MHz)	99% Bandwidth (MHz)
CH01	915.5	0.593	0.457
CH02	916	0.533	0.432
CH03	916.5	0.544	0.453

##### CH01

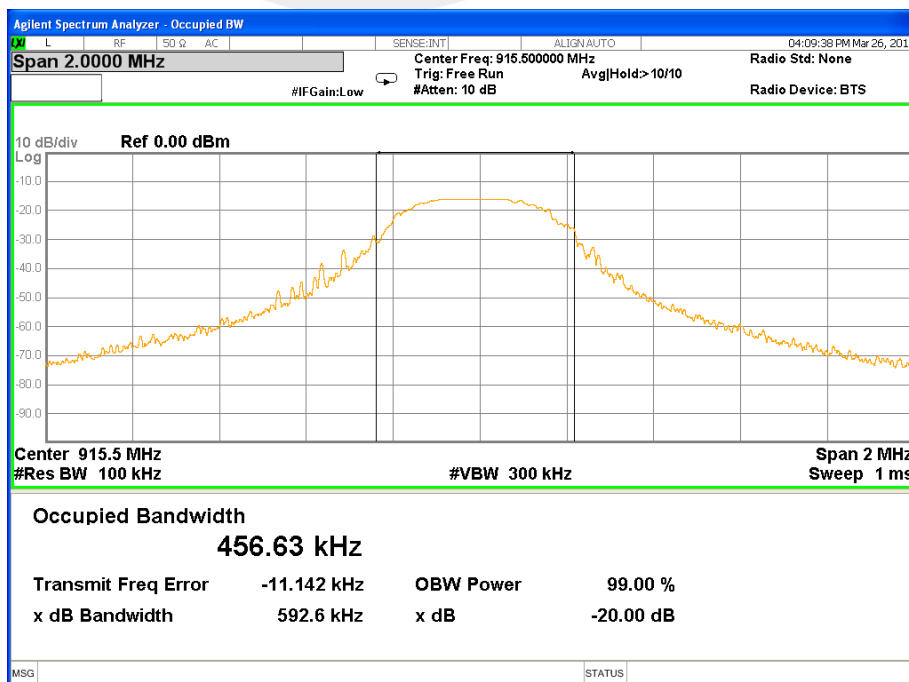



### CH02

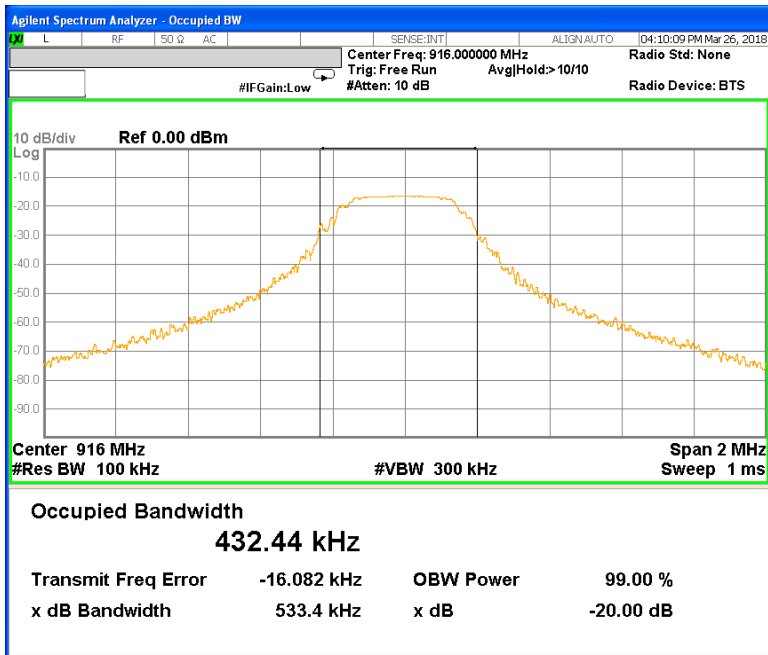

### CH03

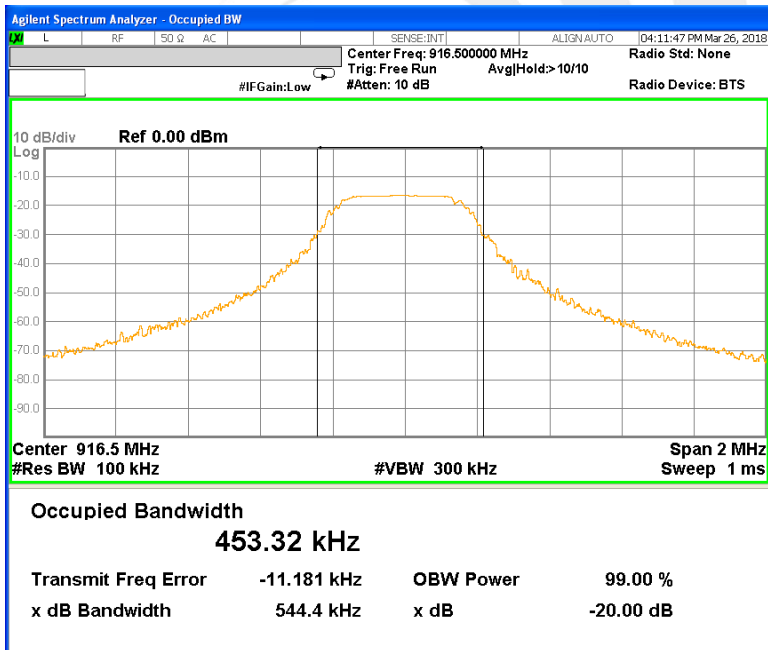



## 5. ANTENNA REQUIREMENT

### 5.1 STANDARD REQUIREMENT

According to the FCC Part 15 Paragraph 15.203, an intentional radiator shall be designed to ensure that no antenna other than that furnished by the responsible party shall be used with the device.

### 5.2 EUT ANTENNA

The EUT antenna is PCB Antenna.It conforms to the standard requirements.





## APPENDIX I- PHOTOS OF TEST SETUP

### Radiated Measurement Photos

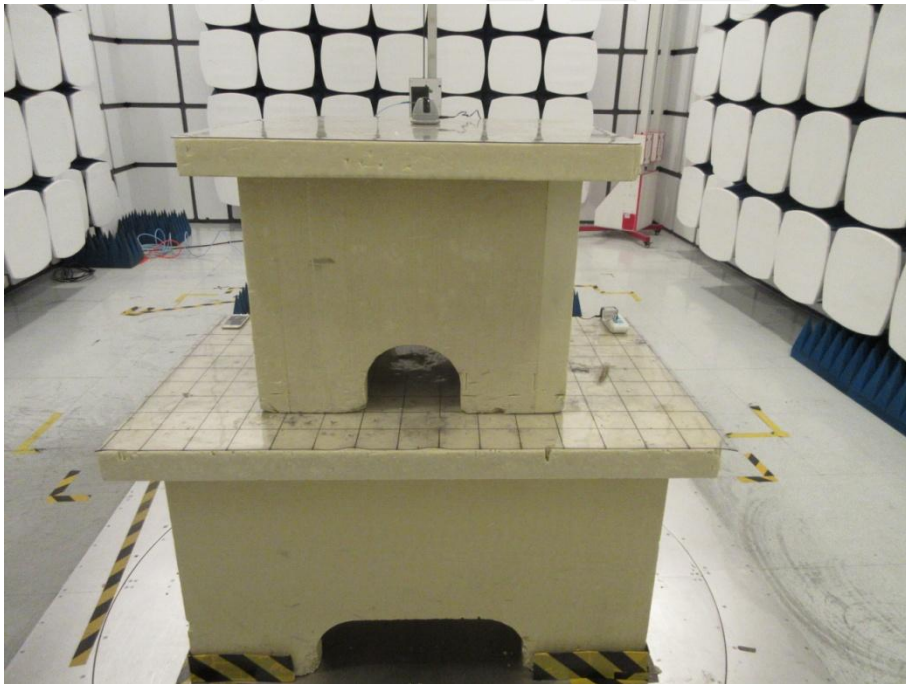



### Conducted Measurement Photos



\*\*\*\*\*END OF THE REPORT\*\*\*\*\*

