



Prüfbericht-Nr.: <i>Test Report No.:</i>	60363496 001	Auftrags-Nr.: <i>Order No.:</i>	158207418	Seite 1 von 17 <i>Page 1 of 17</i>	
Kunden-Referenz-Nr.: <i>Client Reference No.:</i>	N/A	Auftragsdatum: <i>Order date:</i>	12.03.2020		
Auftraggeber: <i>Client:</i>	Wise Ally Holdings Limited Units 3203-3207, Tower 1, Enterprise Square Five, 8 Wang Chiu Road, Kowloon Bay, Hong Kong				
Prüfgegenstand: <i>Test item:</i>	Sigfox Water Rope Detection Sensor				
Bezeichnung / Typ-Nr.: <i>Identification / Type No.:</i>	AM52				
Auftrags-Inhalt: <i>Order content:</i>	FCC Certification				
Prüfgrundlage: <i>Test specification:</i>	FCC Part 15 Subpart C ANSI C63.10-2013				
Wareneingangsdatum: <i>Date of receipt:</i>	12.03.2020				
Prüfmuster-Nr.: <i>Test sample No.:</i>	A001055945-001				
Prüfzeitraum: <i>Testing period:</i>	19.03.2020 - 25.03.2020				
Ort der Prüfung: <i>Place of testing:</i>	Hong Kong				
Prüflaboratorium: <i>Testing laboratory:</i>	TÜV Rheinland Hong Kong Ltd.				
Prüfergebnis*: <i>Test result*:</i>	Pass				
geprüft von / tested by:					
 20.04.2020 Benny Lau / Senior Project Manager		 20.04.2020 Sharon Li / Senior Unit Manager			
Datum <i>Date</i>	Name / Stellung <i>Name / Position</i>	Unterschrift <i>Signature</i>	Datum <i>Date</i>	Name / Stellung <i>Name / Position</i>	Unterschrift <i>Signature</i>
Sonstiges / Other: FCC ID: 2AGEG-AM52					
Zustand des Prüfgegenstandes bei Anlieferung: <i>Condition of the test item at delivery:</i>		Prüfmuster vollständig und unbeschädigt <i>Test item complete and undamaged</i>			
* Legende: 1 = sehr gut 2 = gut 3 = befriedigend 4 = ausreichend 5 = mangelhaft P(ass) = entspricht o.g. Prüfgrundlage(n) F(ail) = entspricht nicht o.g. Prüfgrundlage(n) N/A = nicht anwendbar N/T = nicht getestet Legend: 1 = very good 2 = good 3 = satisfactory 4 = sufficient 5 = poor P(ass) = passed a.m. test specification(s) F(ail) = failed a.m. test specification(s) N/A = not applicable N/T = not tested					
<p>Dieser Prüfbericht bezieht sich nur auf das o.g. Prüfmuster und darf ohne Genehmigung der Prüfstelle nicht auszugsweise vervielfältigt werden. Dieser Bericht berechtigt nicht zur Verwendung eines Prüfzeichens.</p> <p><i>This test report only relates to the a. m. test sample. Without permission of the test center this test report is not permitted to be duplicated in extracts. This test report does not entitle to carry any test mark.</i></p>					

Table of Content

	Page
Cover Page	1
Table of Content	2
Product information	4
Manufacturers declarations	4
Product function and intended use.....	4
Submitted documents.....	4
Independent Operation Modes	4
Related Submittal(s) Grants	4
Remark	4
Test Set-up and Operation Mode	5
Principle of Configuration Selection	5
Test Operation and Test Software.....	5
Special Accessories and Auxiliary Equipment	5
Countermeasures to achieve EMC Compliance	5
Test Methodology	6
Radiated Emission	6
Field Strength Calculation.....	6
Test Setup Diagram	7
Test Facility	9
Test Laboratory Information	9
List of Test and Measurement Instruments	10
Measurement Uncertainty	11
Results FCC Part 15 – Subpart C	12
FCC 15.203 – Antenna Requirement 1	Pass..... 12
FCC 15.204 – Antenna Requirement 2	Pass..... 12
FCC 15.207 – Conducted Emission on AC Mains	N/A..... 12
FCC 15.247 (b)(1) – Peak Output Power.....	Pass..... 12
FCC 15.247 (a) – 20 dB Bandwidth	Pass..... 13
FCC 15.247(a)(1)– Carrier Frequency Separation	Pass..... 13
FCC 15.247 (a)(1)(iii)– Number of hopping channels.....	Pass..... 14
FCC 15.247 (a)(1)(iii) – Time of Occupancy (Dwell Time).....	Pass..... 14

FCC 15.247 (a) – Hopping Sequence..... Pass..... 15

FCC 15.247 (a) – Equal Hopping Frequency Use Pass..... 15

FCC 15.247 (a) – Receiver Input Bandwidth Pass..... 15

FCC 15.247 (a) – Receiver Hopping Capability Pass..... 15

FCC 15.247 (d) – Spurious Conducted Emissions..... Pass..... 16

FCC 15.205– Radiated Emissions in Restricted Frequency Bands Pass..... 16

Appendix 1 – Test protocols 16 pages

Appendix 2 – Test setup 2 pages

Appendix 3 – EUT External Photos 4 pages

Appendix 4 – EUT Internal Photos 3 pages

Appendix 5 – RF exposure information..... 2 pages

Product information

Manufacturers declarations

	Transceiver
Operating frequency range	902.1375 - 904.6625 MHz
Type of modulation	Frequency Hopping Spread Spectrum
Number of channels	54
Channel separation	25 kHz
Type of antenna	Dipole Antenna
Antenna gain (dBi)	0 dBi
Power level	fix
Type of equipment	stand alone radio device
Connection to public utility power line	No
Nominal voltage	3.0 VDC
Independent Operation Modes	Transmit and receive

Product function and intended use

The equipment under test (EUT) is a Sigfox Water detection sensor. It is powered by 2 x 1.5V AA batteries.

FCC ID: 2AGEG-AM52

Models	Product description
AM52	Sigfox Water Rope Detection Sensor

Submitted documents

Circuit Diagram
 Block Diagram
 Technical Description
 User manual
 Label

Independent Operation Modes

The basic operation modes are:

- Transmitting mode.

For further information refer to User Manual

Related Submittal(s) Grants

This is a single application for certification of the transmitter.
 The receiver part is authorized by SDOC. For the test result, please refer to the test report 60363497 001 issued by TÜV Rheinland Hong Kong Ltd.

Remark

The test results in this test report are only relevant to the tested sample and does not involve any assessment in the production.

Test Set-up and Operation Mode

Principle of Configuration Selection

Emission: The equipment under test (EUT) was configured to measure its highest possible radiation level. The test modes were adapted accordingly in reference to the instructions for use.

Test Operation and Test Software

Test operation should refer to test methodology.

- During test, Channel & Power Controlling Software provided by the customer was used to control the operating channel as well as the output power level. The RF output power (power = 14dBm) was selected according to the instruction given by the manufacturer. The setting of the RF output power expected by the customer shall be fixed on the firmware of the final end product.

Special Accessories and Auxiliary Equipment

The product has been tested together with the following additional accessories:

- NIL

Countermeasures to achieve EMC Compliance

- NIL

Test Methodology

Radiated Emission

The radiated emission measurements of the transmitter part were performed according to the procedures in ANSI C63.10-2013.

For measurement below 1GHz - the equipment under test (EUT) was placed at the middle of the 80 cm height turntable. For measurement above 1GHz - the EUT was placed at the middle of the 1.5 m height turntable and RF absorbing material was placed on ground plane between turntable and measuring antenna. During the testing, the EUT was operated standalone and arranged for maximum emissions. The EUT was tested in three orthogonal planes.

The investigation is performed with the EUT rotated 360°, the antenna height scanned between 1m and 4m, and the antenna rotated to repeat the measurements for both the horizontal and vertical antenna polarizations. Repeat the measurement steps until the maximum emissions were obtained.

All radiated tests were performed at an antenna to EUT with 3 meters distance, unless stated otherwise in particular parts of this test report.

Field Strength Calculation

The field strength at 3 m was established by adding the meter reading of the spectrum analyzer to the factors associated with antenna correction factor, cable loss, preamplifiers and filter attenuation.

The equation is expressed as follow:

$$FS = R + AF + CF + FA - PA$$

Where FS = Field Strength in dBuV/m at 3 meters.
R = Reading of Spectrum Analyzer in dBuV.
AF = Antenna Factor in dB.
CF = Cable Attenuation Factor in dB.
FA = Filter Attenuation Factor in dB.
PA = Preamplifier Factor in dB.

FA and PA are only be used for the measuring frequency above 1 GHz.

Test Setup Diagram

Diagram of Measurement Configuration for Radiation Test

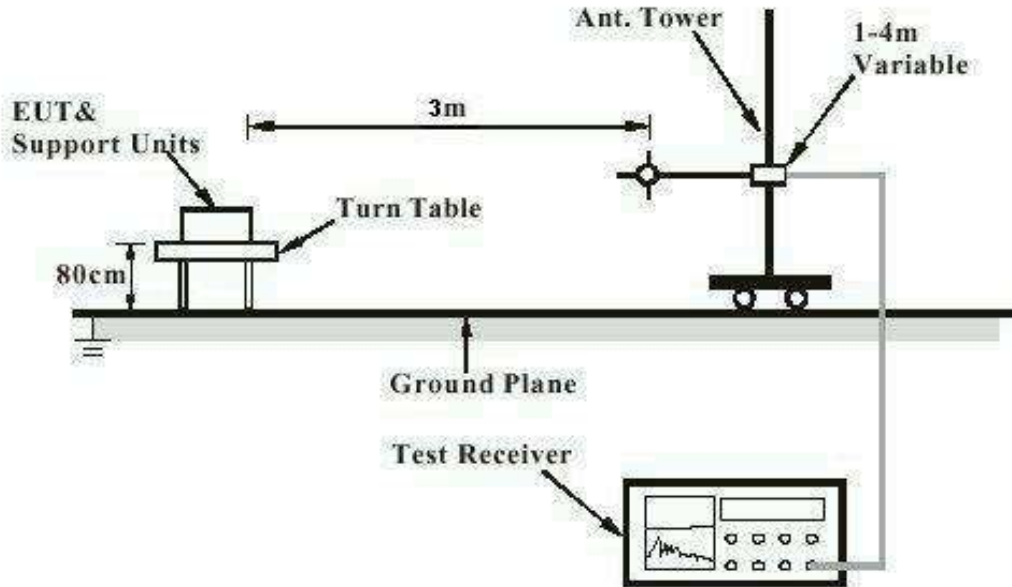

Note: Measurements above 1 GHz are done with a table height of 1.5m. In addition, there is RF absorbing material on the floor of the test site for above 1GHz measurement.

Diagram of Measurement Equipment Configuration for Mains Conduction Measurement (if applicable)

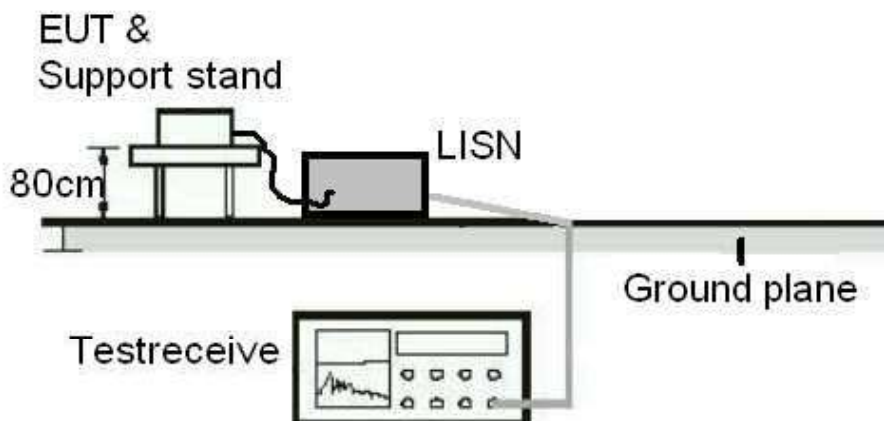
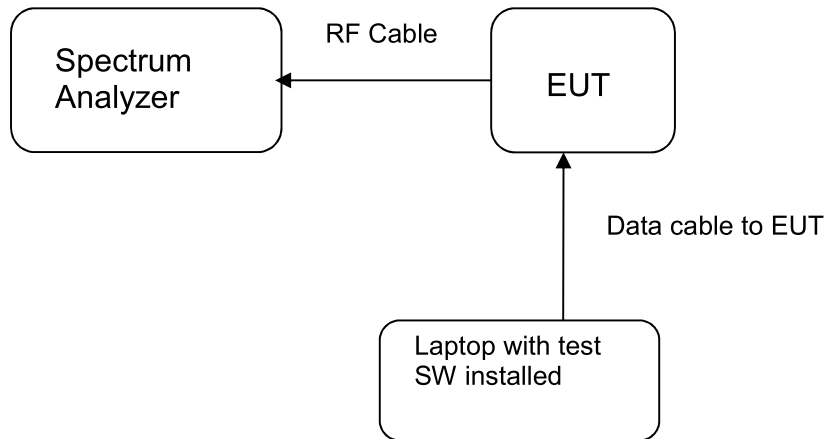

Diagram of Equipment Configuration for Antenna-port Conducted Measurement (if applicable)



Test Facility

Test Laboratory Information

TÜV Rheinland Hong Kong Ltd.

Address: 3-4, 11/F., Fou Wah Industrial Building, 10-16 Pun Shan Street, Tsuen Wan, N.T., Hong Kong

Tel.: +852 2192 1000

Fax: +852 2192 1001

Email service-gc@tuv.com

Web: www.tuv.com

The test facility is recognized or accredited by the following organizations:

FCC

Type	: Accredited Test Firm
Designation Number	: HK0013
Test Firm Registration Number	: 371735
Scope	: Intentional Radiators

List of Test and Measurement Instruments

Radiated Emission

Equipment	Manufacturer	Type	Cal. Date	Due Date
Semi-anechoic Chamber	Frankonia	Nil	23 Apr 2019	23 Apr 2020
Test Receiver	R & S	ESU26	11 Jun 2019	11 Jun 2020
Bi-conical Antenna	R & S	HK116	07 Mar 2019	07 Mar 2021
Log Periodic Antenna	R & S	HL223	06 Mar 2019	06 Mar 2021
Cable with I-Joint Conector	Huber+Suhner	CNM-NMCMILX800-473	04 Oct 2018	04 Oct 2020
Active Loop Antenna	EMCO	6502	25 Oct 2018	25 Oct 2020
Double-Ridged Waveguide Horn	EMCO	3116	05 Oct 2018	05 Oct 2020
Double-Ridged Waveguide Horn	EMCO	3117	30 Aug 2018	30 Aug 2020
Cable with I-Joint Conector	Huber+Suhner	CNM-NMCMILX800-473	04 Oct 2018	04 Oct 2020
Microwave Preamplifier	COM-POWER Corporation	PAM-118A	25 Jun 2019	25 Jun 2020
High Pass Filter (cutoff freq. =1000MHz)	Trilithic	23042	30 Oct 2019	30 Oct 2021
High Frequency Cable	Pasternack	PE3VNA4001-3M	29 Jan 2020	29 Jan 2021
Horn Antenna	EMCO	3115	28 Mar 2018	28 Mar 2020

Radio Test

Equipment	Manufacturer	Type	Cal. Date	Due Date
Spectrum Analyzer	R & S	FSP30	26 Jun 2019	26 Jun 2020

Measurement Uncertainty

The estimated combined standard uncertainty for power-line conducted emissions measurements is ± 2.42 dB.

The estimated combined standard uncertainty for radiated emissions measurements is ± 4.81 dB (9kHz to 30MHz) and ± 4.62 dB (30MHz to 200MHz) and ± 5.67 dB (200MHz to 1000MHz) and is ± 5.07 dB (1GHz to 8.2GHz) and ± 4.58 dB (8.2GHz to 12.4GHz) and ± 4.78 dB (12.4GHz to 18GHz)

The estimated combined standard uncertainty for antenna conducted emission is ± 2.1 dB

The reported expanded uncertainty of measurement is stated as the standard uncertainty of measurement multiplied by the coverage factor of $k=2$, which for the level of confidence is approximately 95%.

Results FCC Part 15 – Subpart C

FCC 15.203 – Antenna Requirement 1		Pass
FCC Requirement: No antenna other than that furnished by the responsible party shall be used with the device		
Results:	a) Antenna type:	Dipole antenna
	b) Manufacturer and model no:	N/A
	c) Peak Gain:	0 dBi
Verdict:	Pass	

FCC 15.204 – Antenna Requirement 2		Pass
FCC Requirement: An intentional radiator may be operated only with the antenna with which it is authorized. If an antenna is marketed with the intentional radiator, it shall be of a type which is authorized with the intentional radiator.		
Results:	Only one integral antenna can be used.	
Verdict:	N/A	

FCC 15.207 – Conducted Emission on AC Mains		N/A
There is no AC power input or output ports on the EUT.		

FCC 15.247 (b)(1) – Peak Output Power		Pass			
FCC Requirement :					
For frequency hopping systems operating in the 902-928 MHz band: 1 watt for systems employing at least 50 hopping channels; and, 0.25 watts for systems employing less than 50 hopping channels, but at least 25 hopping channels.					
Test Specification : ANSI C63.10 – 2013 Test date : 23.03.2020 Mode of operation : Tx mode Port of testing : Temporary antenna port Supply voltage : 3.0 VDC Temperature : 23°C Humidity : 50%					
Results: For test protocols please refer to Appendix 1.					
Frequency (MHz)	Measured level (dBm)	Cable loss (dB)	Maximum peak output power (dBm)	Limit (dBm)	Verdict
902.1375	22.08	0.5	22.58	30.0	Pass
903.3875	22.16	0.5	22.66	30.0	Pass
904.6625	22.18	0.5	22.68	30.0	Pass

FCC 15.247 (a) – 20 dB Bandwidth		Pass	
FCC Requirement:			
For frequency hopping systems operating in the 902-928 MHz band: The maximum allowed 20 dB bandwidth of the hopping channel is 500 kHz.			
Test Specification : ANSI C63.10 – 2013 Test date : 23.03.2020 Mode of operation : Tx mode Port of testing : Temporary antenna port Supply voltage : 3.0 VDC Temperature : 23°C Humidity : 50%			
Results: Pre-scan has been conducted to determine the worst-case mode from all possible combinations between available modulations and packet types. For test protocols refer to Appendix 1.			
Frequency (MHz)	20 dB left (MHz)	20 dB right (MHz)	20dB bandwidth (kHz)
902.1375	902.1222	902.14394	21.736
903.3875	903.3220	903.34376	21.756
904.6625	904.5459	904.56769	21.788

FCC 15.247(a)(1)– Carrier Frequency Separation		Pass	
FCC Requirement:			
Frequency hopping systems shall have hopping channel carrier frequencies separated by a minimum of 25kHz or the 20dB bandwidth of the hopping channel, whichever is greater.			
Test Specification : ANSI C63.10 – 2013 Test date : 23.03.2020 Mode of operation : Tx mode (hopping on) Port of testing : Temporary antenna port Supply voltage : 3.0 VDC Temperature : 23°C Humidity : 50%			
Results: Pre-scan has been conducted to determine the worst-case mode from all possible combinations between available modulations and packet types. For test Results plots refer to Appendix 1.			
Channel Separation (kHz)	Limit (kHz)	Verdict	
25	25	Pass	

FCC 15.247 (a)(1)(iii)– Number of hopping channels		Pass
FCC Requirement:		
For frequency hopping systems operating in the 902-928 MHz band: if the 20 dB bandwidth of the hopping channel is less than 250 kHz, the system shall use at least 50 hopping frequencies; if the 20 dB bandwidth of the hopping channel is 250 kHz or greater, the system shall use at least 25 hopping frequencies.		
Test Specification : ANSI C63.10 – 2013 Test date : 23.03.2020 Mode of operation : Tx mode (hopping on) Port of testing : Temporary antenna port Supply voltage : 3.0 VDC Temperature : 23°C Humidity : 50%		
Results: For test Results plots refer to Appendix 1.		
No. of hopping channels	Limit	Verdict
54	50	Pass

FCC 15.247 (a)(1)(iii) – Time of Occupancy (Dwell Time)		Pass
FCC Requirement:		
For frequency hopping systems operating in the 902-928 MHz band: if the 20 dB bandwidth of the hopping channel is less than 250 kHz, the average time of occupancy on any frequency shall not be greater than 0.4 seconds within a 20 second period; if the 20 dB bandwidth of the hopping channel is 250 kHz or greater, average time of occupancy on any frequency shall not be greater than 0.4 seconds within a 10 second period.		
Test Specification : ANSI C63.10 – 2013 Test date : 23.03.2020 Mode of operation : Tx mode (hopping on) Port of testing : Temporary antenna port Supply voltage : 3.0 VDC Temperature : 23°C Humidity : 50%		
Results:		
Time period calculation = 20		
Dwell time = 0.244 s <= 0.4 s		
For test protocols please refer to Appendix 1.		
Verdict: Pass		

FCC 15.247 (a) – Hopping Sequence	Pass
<p>FCC Requirement: The system radio frequency (RF) bandwidth is equal to the channel bandwidth multiplied by the number of channels in the hopset. The hopset shall be such that the near-term distribution of frequencies appears random, with sequential hops randomly distributed in both direction and magnitude of change in the hopset, while the long-term distribution appears evenly distributed.</p>	
Refer to Sigfox Specification	

FCC 15.247 (a) – Equal Hopping Frequency Use	Pass
<p>FCC Requirement: Each of the transmitter's hopping channels is used equally on average.</p> <p>The system radio frequency (RF) bandwidth is equal to the channel bandwidth multiplied by the number of channels in the hopset. The hopset shall be such that the near-term distribution of frequencies appears random, with sequential hops randomly distributed in both direction and magnitude of change in the hopset, while the long-term distribution appears evenly distributed.</p>	
Refer to Sigfox Specification	

FCC 15.247 (a) – Receiver Input Bandwidth	Pass
<p>FCC Requirement: The associated receiver(s) complies with the requirement that its input bandwidth matches the bandwidth of the transmitted signal.</p>	
Refer to Sigfox Specification	

FCC 15.247 (a) – Receiver Hopping Capability	Pass
<p>FCC Requirement: The associated receiver has the ability to shift frequencies in synchronisation with the transmitted signals.</p>	
Refer to Sigfox Specification	

FCC 15.247 (d) – Spurious Conducted Emissions					Pass
FCC Requirement: In any 100 kHz bandwidth outside the frequency band in which the spread spectrum or digitally modulated intentional radiator is operating, the radio frequency power that is produced by the intentional radiator shall be at least 20 dB below that in the 100 kHz bandwidth within the band that contains the highest level of the desired power, based on either an RF conducted or a radiated measurement.					
Test Specification : ANSI C63.10 – 2013 Test date : 23.03.2020 Mode of operation : Tx mode Port of testing : Temporary antenna port Supply voltage : 3.0 VDC Temperature : 23 °C Humidity : 50 %					
Results: Pre-scan has been conducted to determine the worst-case mode from all possible combinations between available modulations and packet types. There is no peak found outside any 100kHz bandwidth of the operating frequency band in the three transmit frequency. All three transmit frequency modes comply with the stated in subclause 15.247(d). For test protocols refer to Appendix 1.					
limit					
Operating frequency (MHz)	Spurious frequency (MHz)	Spurious Level (dBm)	Reference value (dBm)	Delta (dB)	Verdict
902.1375	902.000	1.07	21.93	20.86	Pass
903.3875	1808.000	-21.16	22.18	43.34	Pass
904.6625	1808.000	-20.70	22.08	40.78	Pass

FCC 15.205– Radiated Emissions in Restricted Frequency Bands			Pass
Test Specification : ANSI C63.10 – 2013 Test Date : 20.01.2020 Mode of operation : Tx mode Port of testing : Enclosure Frequency range : 9kHz – 10GHz Supply voltage : 3.0 VDC Temperature : 23°C Humidity : 50%			
FCC Requirement: In any 100kHz bandwidth outside the frequency band at least 20dB below the highest level of the desired power. In addition, radiated emissions which fall in the restricted bands, as defined in section 15.205(a), must also comply with the radiated emission limits specified in section 15.205(c).			
Results: Pre-scan has been conducted to determine the worst-case mode from all possible combinations between available modulations and data rate. All three transmit frequency modes comply with the field strength within the restricted bands. There is no spurious found below 30MHz.			
Mode: 902.1375 MHz TX		Vertical Polarization	
Freq MHz	Level dBuV/m	Limit/ Detector dBuV/m	

1804.264	51.7	74.0 / PK
1804.264	49.5	54.0 / AV
7217.056	51.0	74.0 / PK
7217.056	45.8	54.0 / AV
Mode: 902.1375 MHz TX Horizontal Polarization		
Freq MHz	Level dBuV/m	Limit/ Detector dBuV/m
1804.264	48.8	74.0 / PK
1804.264	45.9	54.0 / AV
7217.056	48.8	74.0 / PK
7217.056	41.9	54.0 / AV
Mode: 903.3875 MHz TX Vertical Polarization		
Freq MHz	Level dBuV/m	Limit/ Detector dBuV/m
1806.763	51.7	74.0 / PK
1806.763	49.5	54.0 / AV
Mode: 903.3875 MHz TX Horizontal Polarization		
Freq MHz	Level dBuV/m	Limit/ Detector dBuV/m
1806.763	48.3	74.0 / PK
1806.763	45.7	54.0 / AV
2710.145	42.2	74.0 / PK
2710.145	35.5	54.0 / AV
Mode: 904.6625 MHz TX Vertical Polarization		
Freq MHz	Level dBuV/m	Limit/ Detector dBuV/m
1809.314	52.3	74.0 / PK
1809.314	20.1	54.0 / AV
2713.970	40.3	74.0 / PK
2713.970	33.0	54.0 / AV
Mode: 904.6625 MHz TX Horizontal Polarization		
Freq MHz	Level dBuV/m	Limit/ Detector dBuV/m
1809.314	49.4	74.0 / PK
1809.314	46.6	54.0 / AV