

REVISIONS			
REV.	ECO	DESCRIPTION	EFFECTIVE DATE
01	DC00799	INITIAL RELEASE	SEE DCO

NOTE: (UNLESS OTHERWISE SPECIFIED)

1. ALL UNDIMENSIONED FEATURES TO BE CONTROLLED VIA 3D CAD FILE AS APPROVED BY EARLENS CORP. ALL UNDIMENSIONED FEATURES TO CONFORM TO TOLERANCE TABLE.
2. PAD PRINTED "FCC ID" LOGO:
  1. PRINT PER THE ARTWORK IN AS00909\_ARTWORK.DXF, WHICH CONTAINS THE ARTWORK AT THE 1:1 SCALE.
  2. COLOR: BLACK (RGB 0/0/0).
  3. POSITION AND SIZE: REFER TO AS00909\_ARTWORK.DXF AND TO DIMENSIONS ON THE DRAWING.
  4. QUALITY OF THE PRINT: NO INCOMPLETE, DISTORTED OR BLURRED PRINTS ALLOWED.
3. OVAL DENOTES CONTROL DIMENSIONS. DIMENSIONS IN PARENTHESIS EXCLUDED FROM FAI.
4. PART SHALL BE CLEAN AND FREE FROM FOREIGN MATERIAL. DIRT, OIL, GREASE, MOLD RELEASE, OR OTHER CONTAMINANTS ARE NOT ALLOWED.
5. THIS PART IS PART OF A RoHS COMPLIANT PRODUCT. FABRICATION MATERIALS AND PROCESS SHALL RESULT IN A RoHS COMPLIANT ITEM.
6. NO CHANGES SHALL BE ALLOWED ON PRODUCTION MATERIALS, PROCESSES, OR MANUFACTURING LOCATION WITHOUT PRIOR WRITTEN APPROVAL BY EARLENS CORPORATION.

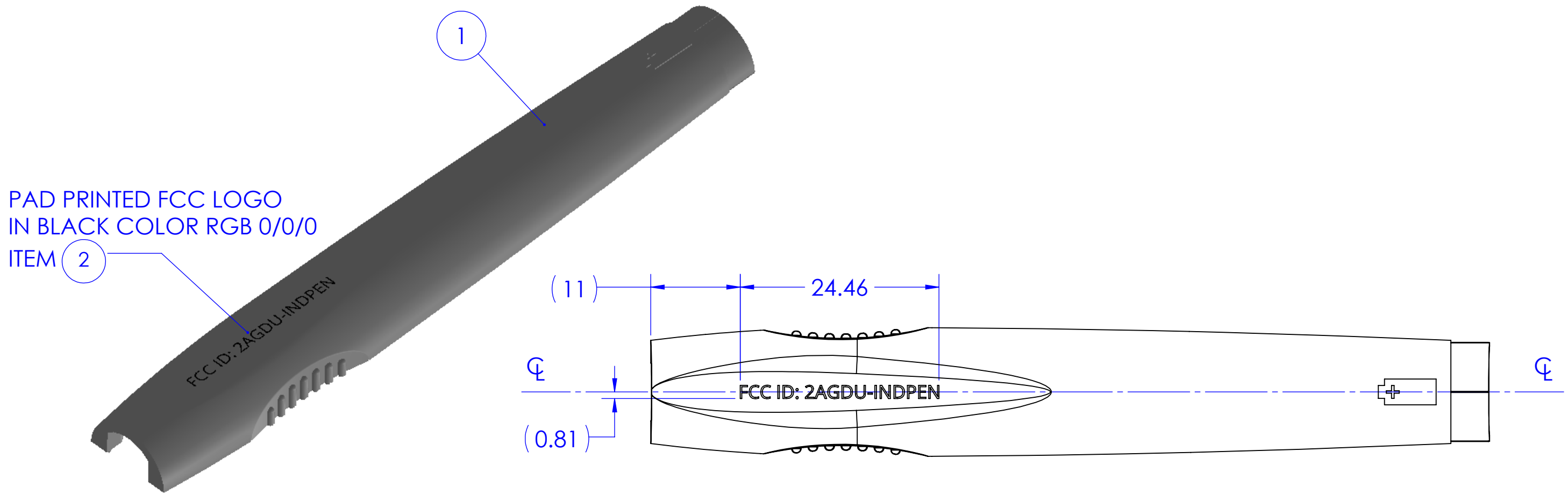

ITEM NUMBER	PART NUMBER	DESCRIPTION	QTY
1	CSF00910	Handle, Bottom, Inductive Pen	1
2	N/A	BLACK PAD PRINTING INK	AR

<b>PROPRIETARY AND CONFIDENTIAL</b>	UNLESS OTHERWISE SPECIFIED, DIMENSIONS ARE IN mm [inch] AND TOLERANCES ARE: LINEAR 0 - 6 [0.236] = ±.05 [0.002] > 6 - 30 [1.181] = ±.10 [0.004] > 30 - 120 [4.724] = ±.15 [0.006] > 120 - 400 [15.748] = ±.20 [0.008] > 400 [15.748] = ±.30 [0.012] RADIAL 0 - 3 = ±0.2 > 3 - 6 = ±0.5 > 6 = ±1.0 FINISH OR BETTER	DRAWN J. JONVAUX	DATE 05/22/2019	EARLENS Corp. 4045A CAMPBELL AVE. MENLO PARK, CA 94025
		CHECKED	DATE 05/22/2019	
THE INFORMATION CONTAINED IN THIS DRAWING IS THE SOLE PROPERTY OF EARLENS. ANY REPRODUCTION IN PART OR AS A WHOLE WITHOUT THE WRITTEN PERMISSION OF EARLENS IS PROHIBITED.	INTERPRET DIMENSIONS AND TOLERANCES PER ASME Y14.5-2009	3D FILE: AS00909v01.SLDPRT	TITLE: Pad Printed Handle, Bottom, Inductive Pen	SIZE DWG REV <b>B</b> AS00909 01
		2D FILE: AS00909v01.SLDDRW	SCALE 2:1	