

## FCC Test Report

**Report No.:** RF170922C07-1

**FCC ID:** 2AGDE-WRT3061

**Test Model:** WRT3061

**Received Date:** Sep. 22, 2017

**Test Date:** Oct. 11, 2017 ~ Dec. 02, 2017

**Issued Date:** Dec. 05, 2017

**Applicant:** WondaLink Inc.

**Address:** 2F, No. 23, R&D Road 2 Science-Based Industrial Park Hsin-Chu Taiwan  
R.O.C

**Issued By:** Bureau Veritas Consumer Products Services (H.K.) Ltd., Taoyuan Branch

**Lab Address:** No. 47-2, 14th Ling, Chia Pau Vil., Lin Kou Dist., New Taipei City, Taiwan  
( R.O.C )

**Test Location:** No. 19, Hwa Ya 2nd Rd, Wen Hwa Tsuen, Kwei Shan Hsiang, Taoyuan  
Hsien 333, Taiwan, R.O.C.

**FCC Registration /  
Designation Number:** 788550 / TW0003



This report is for your exclusive use. Any copying or replication of this report to or for any other person or entity, or use of our name or trademark, is permitted only with our prior written permission. This report sets forth our findings solely with respect to the test samples identified herein. The results set forth in this report are not indicative or representative of the quality or characteristics of the lot from which a test sample was taken or any similar or identical product unless specifically and expressly noted. Our report includes all of the tests requested by you and the results thereof based upon the information that you provided to us. You have 60 days from date of issuance of this report to notify us of any material error or omission caused by our negligence, provided, however, that such notice shall be in writing and shall specifically address the issue you wish to raise. A failure to raise such issue within the prescribed time shall constitute your unqualified acceptance of the completeness of this report, the tests conducted and the correctness of the report contents. Unless specific mention, the uncertainty of measurement has been explicitly taken into account to declare the compliance or non-compliance to the specification. The report must not be used by the client to claim product certification, approval, or endorsement by TAF or any government agencies.

## Table of Contents

<b>Release Control Record</b> .....	<b>4</b>
<b>1 Certificate of Conformity</b> .....	<b>5</b>
<b>2 Summary of Test Results</b> .....	<b>6</b>
2.1 Measurement Uncertainty.....	6
2.2 Modification Record .....	6
<b>3 General Information</b> .....	<b>7</b>
3.1 General Description of EUT .....	7
3.2 Description of Test Modes.....	8
3.2.1 Test Mode Applicability and Tested Channel Detail.....	9
3.3 Duty Cycle of Test Signal .....	11
3.4 Description of Support Units .....	12
3.4.1 Configuration of System under Test .....	12
3.5 General Description of Applied Standards.....	12
<b>4 Test Types and Results</b> .....	<b>13</b>
4.1 Radiated Emission and Bandedge Measurement .....	13
4.1.1 Limits of Radiated Emission and Bandedge Measurement .....	13
4.1.2 Limits of Unwanted Emission Out of the Restricted Bands .....	14
4.1.3 Test Instruments .....	15
4.1.4 Test Procedures.....	16
4.1.5 Deviation from Test Standard .....	16
4.1.6 Test Set Up .....	17
4.1.7 EUT Operating Conditions.....	18
4.1.8 Test Results .....	19
4.2 Conducted Emission Measurement.....	28
4.2.1 Limits of Conducted Emission Measurement .....	28
4.2.2 Test Instruments .....	28
4.2.3 Test Procedures.....	29
4.2.4 Deviation from Test Standard .....	29
4.2.5 Test Setup.....	29
4.2.6 EUT Operating Conditions.....	29
4.2.7 Test Results .....	30
4.3 Transmit Power Measurement.....	32
4.3.1 Limits of Transmit Power Measurement .....	32
4.3.2 Test Setup.....	32
4.3.3 Test Instruments .....	33
4.3.4 Test Procedure .....	33
4.3.5 Deviation from Test Standard .....	33
4.3.6 EUT Operating Conditions.....	33
4.3.7 Test Result .....	34
4.4 Occupied Bandwidth Measurement.....	36
4.4.1 Test Setup.....	36
4.4.2 Test Instruments .....	36
4.4.3 Test Procedure .....	36
4.4.4 Test Results .....	37
4.5 Peak Power Spectral Density Measurement .....	38
4.5.1 Limits of Peak Power Spectral Density Measurement .....	38
4.5.2 Test Setup.....	38
4.5.3 Test Instruments .....	38
4.5.4 Test Procedures.....	38
4.5.5 Deviation from Test Standard .....	39
4.5.6 EUT Operating Conditions.....	39
4.5.7 Test Results .....	39
4.6 Frequency Stability .....	43

4.6.1	Limit of Frequency Stability Measurement .....	43
4.6.2	Test Setup .....	43
4.6.3	Test Instruments .....	43
4.6.4	Test Procedure .....	43
4.6.5	Deviation from Test Standard .....	43
4.6.6	EUT Operating Condition .....	43
4.6.7	Test Results .....	44
4.7	6 dB Bandwidth Measurement.....	45
4.7.1	Limits of 6 dB Bandwidth Measurement.....	45
4.7.2	Test Setup.....	45
4.7.3	Test Instruments .....	45
4.7.4	Test Procedure .....	45
4.7.5	Deviation from Test Standard .....	45
4.7.6	EUT Operating Condition .....	45
4.7.7	Test Results .....	46
<b>5</b>	<b>Pictures of Test Arrangements.....</b>	<b>47</b>
	<b>Annex A- Radiated Out of Band Emisison (OOBE) Measurement (For U-NII-3 band) .....</b>	<b>48</b>
	<b>Appendix – Information on the Testing Laboratories .....</b>	<b>49</b>

### Release Control Record

Issue No.	Description	Date Issued
RF170922C07-1	Original Release	Dec. 05, 2017

## 1 Certificate of Conformity

**Product:** VoLTE& LTE Router  
**Brand:** WondaLink  
**Test Model:** WRT3061  
**Sample Status:** Identical Prototype  
**Applicant:** WondaLink Inc.  
**Test Date:** Oct. 11, 2017 ~ Dec. 02, 2017  
**Standards:** 47 CFR FCC Part 15, Subpart E (Section 15.407)  
ANSI C63.10:2013

The above equipment has been tested by **Bureau Veritas Consumer Products Services (H.K.) Ltd., Taoyuan Branch**, and found compliance with the requirement of the above standards. The test record, data evaluation & Equipment Under Test (EUT) configurations represented herein are true and accurate accounts of the measurements of the sample's EMC characteristics under the conditions specified in this report.

**Prepared by :** Gina Liu , **Date:** Dec. 05, 2017  
Gina Liu / Specialist

**Approved by :** Dylan Chiou , **Date:** Dec. 05, 2017  
Dylan Chiou / Project Engineer

## 2 Summary of Test Results

47 CFR FCC Part 15, Subpart E (Section 15.407)			
FCC Clause	Test Item	Result	Remarks
15.407(b)(6)	AC Power Conducted Emissions	Pass	Meet the requirement of limit. Minimum passing margin is -15.96 dB at 0.40605 MHz.
15.407(b) (1/2/3/4(i/ii)/6)	Radiated Emissions & Band Edge Measurement	Pass	Meet the requirement of limit. Minimum passing margin is -0.2 dB at 10360 MHz.
15.407(a)(1/2/3)	Max Average Transmit Power	Pass	Meet the requirement of limit.
---	Occupied Bandwidth Measurement	-	Reference only
15.407(a)(1/2/3)	Peak Power Spectral Density	Pass	Meet the requirement of limit.
15.407(e)	6 dB Bandwidth	Pass	Meet the requirement of limit. (U-NII-3 Band only)
15.407(g)	Frequency Stability	Pass	Meet the requirement of limit.
15.203	Antenna Requirement	Pass	No antenna connector is used.

\*For U-NII-3 band compliance with rule part 15.407(b)(4)(i), the OOB test plots were recorded in Annex A.

### 2.1 Measurement Uncertainty

Where relevant, the following measurement uncertainty levels have been estimated for tests performed on the EUT as specified in CISPR 16-4-2:

Measurement	Frequency	Expanded Uncertainty (k=2) (±)
Conducted Emissions at mains ports	150 kHz ~ 30 MHz	2.44 dB
Radiated Emissions up to 1 GHz	30 MHz ~ 200 MHz	2.93 dB
	200 MHz ~ 1000 MHz	2.95 dB
Radiated Emissions above 1 GHz	1 GHz ~ 18 GHz	2.26 dB
	18 GHz ~ 40 GHz	1.94 dB

### 2.2 Modification Record

There were no modifications required for compliance.

### 3 General Information

#### 3.1 General Description of EUT

<b>Product</b>	VoLTE& LTE Router
<b>Brand</b>	WondaLink
<b>Test Model</b>	WRT3061
<b>Status of EUT</b>	Identical Prototype
<b>Power Supply Rating</b>	12 Vdc (adapter) 7.4 Vdc (Li-ion battery)
<b>Modulation Type</b>	256QAM, 64QAM, 16QAM, QPSK, BPSK
<b>Modulation Technology</b>	OFDM
<b>Transfer Rate</b>	802.11a: 54.0/ 48.0/ 36.0/ 24.0/ 18.0/ 12.0/ 9.0/ 6.0 Mbps 802.11ac: up to MCS9
<b>Operating Frequency</b>	5180 ~ 5240 MHz 5745 ~ 5825 MHz
<b>Number of Channel</b>	5180 ~ 5240 MHz: 4 for 802.11a, 1 for 802.11ac (VHT80) 5745 ~ 5825 MHz: 5 for 802.11a, 1 for 802.11ac (VHT80)
<b>Output Power</b>	176.652 mW for 5180 ~ 5240 MHz 104.158 mW for 5745 ~ 5825 MHz
<b>Antenna Type</b>	PCB antenna with 3.62 dBi gain (5180 ~ 5240 MHz) PCB antenna with 5.21 dBi gain (5745 ~ 5825 MHz)
<b>Antenna Connector</b>	N/A
<b>Accessory Device</b>	Refer to Note as below
<b>Data Cable Supplied</b>	Refer to Note as below
<b>Test Tool Version</b>	QDART_CONN.WIN.1.0 Installer-00037.27

**Note:**

- The EUT incorporates a MIMO function. Physically, the EUT provides three completed transmitters and three receivers.

Modulation Mode	Tx Function
802.11a	3TX
802.11ac (VHT80)	3TX

- The EUT contains following accessory devices.

Product	Brand	Model	Description
Adapter	TUE	KSAS0501200350M2	I/P: 100-240 Vac, 50/60 Hz, 1.2 A O/P: 12 Vdc, 3.5 A 1.45m non-shielded cable w/o core
Battery	Coppercell	CP6000-TE	7.4 Vdc, 5800 mAh

- The above EUT information is declared by manufacturer and for more detailed features description, please refer to the manufacturer's specifications or user's manual.

### 3.2 Description of Test Modes

#### For 5180 ~ 5240 MHz

4 channels are provided for 802.11a:

Channel	Frequency (MHz)	Channel	Frequency (MHz)
36	5180	44	5220
40	5200	48	5240

1 channel is provided for 802.11ac (VHT80):

Channel	Frequency (MHz)
42	5210

#### For 5745 ~ 5825 MHz:

5 channels are provided for 802.11a, 802.11n (HT20):

Channel	Frequency (MHz)	Channel	Frequency (MHz)
149	5745	161	5805
153	5765	165	5825
157	5785		

1 channel is provided for 802.11ac (VHT80):

Channel	Frequency (MHz)
155	5775



### 3.2.1 Test Mode Applicability and Tested Channel Detail

EUT Configure Mode	Applicable To				Description
	RE $\geq$ 1G	RE $<$ 1G	PLC	APCM	
-	√	√	√	√	-

Where **RE $\geq$ 1G**: Radiated Emission above 1 GHz

**RE $<$ 1G**: Radiated Emission below 1 GHz

**PLC**: Power Line Conducted Emission

**APCM**: Antenna Port Conducted Measurement

**Note:**

1. The EUT had been pre-tested on the positioned of each 3 axis. The worst case was found when positioned on **Z-plane**.
2. "-" means no effect.

#### **Radiated Emission Test (Above 1 GHz):**

- Pre-Scan has been conducted to determine the worst-case mode from all possible combinations between available modulations, data rates and antenna ports (if EUT with antenna diversity architecture).
- Following channel(s) was (were) selected for the final test as listed below.

EUT Configure Mode	Frequency Band (MHz)	Mode	Available Channel	Tested Channel	Modulation Technology	Modulation Type	Data Rate (Mbps)
-	5180-5240	802.11a	36 to 48	36, 44, 48	OFDM	BPSK	6.0
-		802.11ac (VHT80)	42	42	OFDM	BPSK	MCS0
-	5745-5825	802.11a	149 to 165	149, 157, 165	OFDM	BPSK	6.0
-		802.11ac (VHT80)	155	155	OFDM	BPSK	MCS0

#### **Radiated Emission Test (Below 1 GHz):**

- Pre-Scan has been conducted to determine the worst-case mode from all possible combinations between available modulations, data rates and antenna ports (if EUT with antenna diversity architecture).
- Following channel(s) was (were) selected for the final test as listed below.

EUT Configure Mode	Frequency Band (MHz)	Mode	Available Channel	Tested Channel	Modulation Technology	Modulation Type	Data Rate (Mbps)
-	5180-5240	802.11a	36 to 48	36	OFDM	BPSK	MCS0
-	5745-5825	802.11a	149 to 165	165	OFDM	BPSK	MCS0

#### **Power Line Conducted Emission Test:**

- Pre-Scan has been conducted to determine the worst-case mode from all possible combinations between available modulations, data rates and antenna ports (if EUT with antenna diversity architecture).
- Following channel(s) was (were) selected for the final test as listed below.

EUT Configure Mode	Frequency Band (MHz)	Mode	Available Channel	Tested Channel	Modulation Technology	Modulation Type	Data Rate (Mbps)
-	5180-5320	802.11a	36 to 48	36	OFDM	BPSK	MCS0

**Antenna Port Conducted Measurement:**

- This item includes all test value of each mode, but only includes spectrum plot of worst value of each mode.
- Pre-Scan has been conducted to determine the worst-case mode from all possible combinations between available modulations, data rates and antenna ports (if EUT with antenna diversity architecture).
- Following channel(s) was (were) selected for the final test as listed below.

EUT Configure Mode	Frequency Band (MHz)	Mode	Available Channel	Tested Channel	Modulation Technology	Modulation Type	Data Rate (Mbps)
-	5180-5240	802.11a	36 to 48	36, 44, 48	OFDM	BPSK	6.0
-		802.11ac (VHT80)	42	42	OFDM	BPSK	MCS0
-	5745-5825	802.11a	149 to 165	149, 157, 165	OFDM	BPSK	6.0
-		802.11ac (VHT80)	155	155	OFDM	BPSK	MCS0

**Test Condition:**

Applicable To	Environmental Conditions	Input Power	Tested by
RE $\geq$ 1G	25 deg. C, 65 % RH	120 Vac, 60 Hz	Getaz Yang
RE $<$ 1G	25 deg. C, 65 % RH	120 Vac, 60 Hz	Gavin Wu
PLC	25 deg. C, 65 % RH	120 Vac, 60 Hz	Getaz Yang
APCM	25 deg. C, 65 % RH	7.4 Vdc	Gavin Wu

### 3.3 Duty Cycle of Test Signal

#### MODULATION TYPE: BPSK

802.11a: Duty cycle =  $2.054/2.124 = 0.967$ , Duty factor =  $10 * \log(1/0.967) = 0.15$

802.11ac (VHT80): Duty cycle =  $1.141/1.215 = 0.939$ , Duty factor =  $10 * \log(1/0.939) = 0.27$

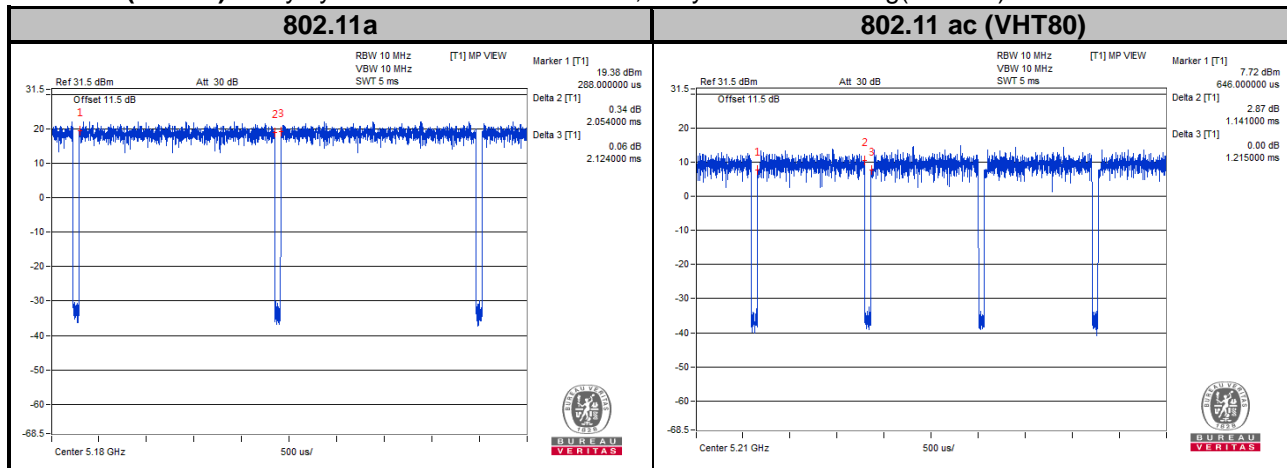

### 3.4 Description of Support Units

The EUT has been tested as an independent unit together with other necessary accessories or support units.

#### 3.4.1 Configuration of System under Test

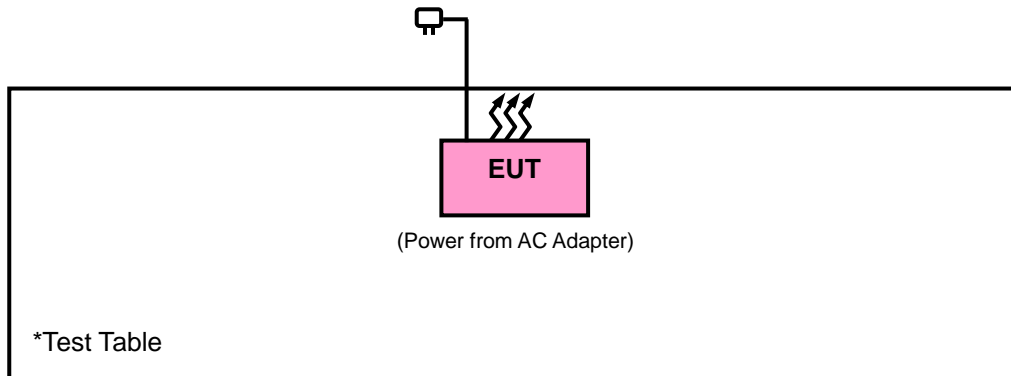

### 3.5 General Description of Applied Standards

The EUT is a RF Product. According to the specifications of the manufacturer, it must comply with the requirements of the following standards:

#### **FCC Part 15, Subpart E (15.407)**

**789033 D02 General UNII Test Procedures New Rules v01r04**

**644545 D01 Guidance for IEEE 802 11ac v01r02**

**662911 D01 Multiple Transmitter Output v02r01**

ANSI C63.10-2013

All test items have been performed and recorded as per the above standards.

**Note:** The EUT has been verified to comply with the requirements of FCC Part 15, Subpart B, Class B (DoC).  
The test report has been issued separately.

## 4 Test Types and Results

### 4.1 Radiated Emission and Bandedge Measurement

#### 4.1.1 Limits of Radiated Emission and Bandedge Measurement

Radiated emissions which fall in the restricted bands must comply with the radiated emission limits specified as below table. Other emissions shall be at least 20 dB below the highest level of the desired power:

Frequencies (MHz)	Field Strength (microvolts/meter)	Measurement Distance (meters)
0.009 ~ 0.490	2400/F (kHz)	300
0.490 ~ 1.705	24000/F (kHz)	30
1.705 ~ 30.0	30	30
30 ~ 88	100	3
88 ~ 216	150	3
216 ~ 960	200	3
Above 960	500	3

**Note:**

1. The lower limit shall apply at the transition frequencies.
2. Emission level (dBuV/m) = 20 log Emission level (uV/m).
3. For frequencies above 1000 MHz, the field strength limits are based on average detector, however, the peak field strength of any emission shall not exceed the maximum permitted average limits, specified above by more than 20 dB under any condition of modulation.

#### 4.1.2 Limits of Unwanted Emission Out of the Restricted Bands

Applicable To		Limit	
789033 D02 General UNII Test Procedures New Rules v01r04		Field Strength at 3 m	
		PK: 74 (dBµV/m)	AV: 54 (dBµV/m)
Frequency Band	Applicable To	EIRP Limit	Equivalent Field Strength at 3 m
5150~5250 MHz	15.407(b)(1)	PK: -27 (dBm/MHz)	PK: 68.2 (dBµV/m)
5250~5350 MHz	15.407(b)(2)		
5470~5725 MHz	15.407(b)(3)		
5725~5850 MHz	15.407(b)(4)(i)	PK:-27 (dBm/MHz) <sup>*1</sup> PK:10 (dBm/MHz) <sup>*2</sup> PK:15.6 (dBm/MHz) <sup>*3</sup> PK:27 (dBm/MHz) <sup>*4</sup>	PK: 68.2 (dBµV/m) <sup>*1</sup> PK:105.2 (dBµV/m) <sup>*2</sup> PK: 110.8 (dBµV/m) <sup>*3</sup> PK:122.2 (dBµV/m) <sup>*4</sup>
	15.407(b)(4)(ii)	Emission limits in section 15.247(d)	

<sup>\*1</sup> beyond 75 MHz or more above of the band edge.

<sup>\*2</sup> below the band edge increasing linearly to 10 dBm/MHz at 25 MHz above.

<sup>\*3</sup> below the band edge increasing linearly to a level of 15.6 dBm/MHz at 5 MHz above.

<sup>\*4</sup> from 5 MHz above or below the band edge increasing linearly to a level of 27 dBm/MHz at the band edge.

**Note:**

The following formula is used to convert the equipment isotropic radiated power (eirp) to field strength:

$$E = \frac{1000000\sqrt{30P}}{3} \mu\text{V/m, where P is the eirp (Watts).$$

#### 4.1.3 Test Instruments

Description & Manufacturer	Model No.	Serial No.	Date of Calibration	Due Date of Calibration
Test Receiver Agilent	N9038A	MY51210203	Feb. 17, 2017	Feb. 16, 2018
Spectrum Analyzer Agilent	N9010A	MY52220314	Dec. 16, 2016	Dec. 15, 2017
Spectrum Analyzer ROHDE & SCHWARZ	FSU43	101261	Dec. 13, 2016	Dec. 12, 2017
BILOG Antenna SCHWARZBECK	VULB9168	9168-472	Dec. 26, 2016	Dec. 27, 2017
HORN Antenna SCHWARZBECK	BBHA 9120 D	9120D-969	Dec. 12, 2016	Dec. 13, 2017
HORN Antenna SCHWARZBECK	BBHA 9170	9170-480	Dec. 14, 2016	Dec. 13, 2017
Fixed Attenuator Mini-Circuits	MDCS18N-10	MDCS18N-10-01	Apr. 17, 2017	Apr. 16, 2018
Loop Antenna	HLA 6121	45745	May 19, 2017	May 18, 2018
Preamplifier EMCI	EMC001340	980201	Nov. 01, 2017	Oct. 31, 2018
Bluetooth Tester	CBT	100946	Jul. 29, 2016	Jul. 28, 2018
Preamplifier EMCI	EMC 012645	980115	Oct. 20, 2017	Oct. 18, 2018
Preamplifier EMCI	EMC 184045	980116	Oct. 20, 2017	Oct. 18, 2018
Preamplifier EMCI	EMC 330H	980112	Oct. 13, 2017	Oct. 12, 2018
Power Meter Anritsu	ML2495A	1012010	Aug. 15, 2017	Aug. 14, 2018
Power Sensor Anritsu	MA2411B	1315050	Aug. 15, 2017	Aug. 14, 2018
RF signal cable HUBER+SUHNNER	SUCOFLEX 104	309219/4 2950114	Oct. 20, 2017	Oct. 19, 2018
RF signal cable HUBER+SUHNNER	SUCOFLEX 104	250130/4	Oct. 20, 2017	Oct. 19, 2018
RF Coaxial Cable Worken	8D-FB	Cable-Ch10-01	Oct. 20, 2017	Oct. 19, 2018
Software BV ADT	E3 6.120103	NA	NA	NA
Antenna Tower MF	MFA-440H	NA	NA	NA
Turn Table MF	MFT-201SS	NA	NA	NA
Antenna Tower & Turn Table Controller MF	MF-7802	NA	NA	NA
Temperature & Humidity Chamber	GTH-120-40-CP-AR	MAA1306-019	Sep. 08, 2017	Sep. 07, 2018
DC Power Supply Topward	33010D	807748	Oct. 25, 2016	Oct. 24, 2018
Digital Multimeter Fluke	87-III	70360742	Jun. 30, 2017	Jun. 29, 2018

- Note:
1. The calibration interval of the above test instruments is 12 / 24 months and the calibrations are traceable to NML/ROC and NIST/USA.
  2. The test was performed in HwaYa Chamber 10.
  3. The horn antenna and preamplifier (model: EMC 184045) are used only for the measurement of emission frequency above 1 GHz if tested.
  4. The IC Site Registration No. is IC7450F-10.

#### 4.1.4 Test Procedures

- a. The EUT was placed on the top of a rotating table 0.8 meters (for below 1 GHz) / 1.5 meters (for above 1 GHz) above the ground at 3 meter chamber room for test. The table was rotated 360 degrees to determine the position of the highest radiation.
- b. The EUT was set 3 meters away from the interference-receiving antenna, which was mounted on the top of a variable-height antenna tower.
- c. The height of antenna is varied from one meter to four meters above the ground to determine the maximum value of the field strength. Both horizontal and vertical polarizations of the antenna are set to make the measurement.
- d. For each suspected emission, the EUT was arranged to its worst case and then the antenna was tuned to heights from 1 meter to 4 meters and the rotatable table was turned from 0 degrees to 360 degrees to find the maximum reading.
- e. The test-receiver system was set to quasi-peak detect function and specified bandwidth with maximum hold mode when the test frequency is below 1 GHz.
- f. The test-receiver system was set to peak and average detected function and specified bandwidth with maximum hold mode when the test frequency is above 1 GHz. If the peak reading value also meets average limit, measurement with the average detector is unnecessary.

**Note:**

1. The resolution bandwidth and video bandwidth of test receiver/spectrum analyzer is 120 kHz & 360 kHz for Quasi-peak detection (QP) at frequency below 1 GHz.
2. The resolution bandwidth of test receiver/spectrum analyzer is 1 MHz and the video bandwidth is 3 MHz for Peak detection (PK) at frequency above 1 GHz.
3. The resolution bandwidth of test receiver/spectrum analyzer is 1 MHz and the video bandwidth is 1/T for Average (Duty cycle < 98 %) detection at frequency above 1 GHz.
4. The resolution bandwidth of test receiver/spectrum analyzer is 1 MHz and the video bandwidth is 10 Hz (Duty cycle ≥ 98 %) for Average detection (AV) at frequency above 1 GHz.
5. All modes of operation were investigated and the worst-case emissions are reported.

#### 4.1.5 Deviation from Test Standard

No deviation.



#### 4.1.6 Test Set Up

##### <Radiated emission below 30 MHz>

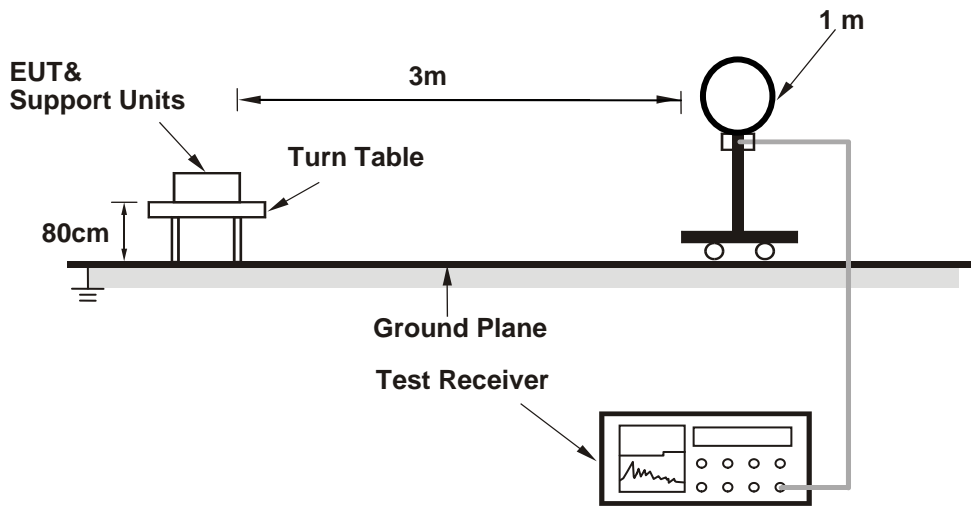

##### <Frequency Range below 1 GHz>

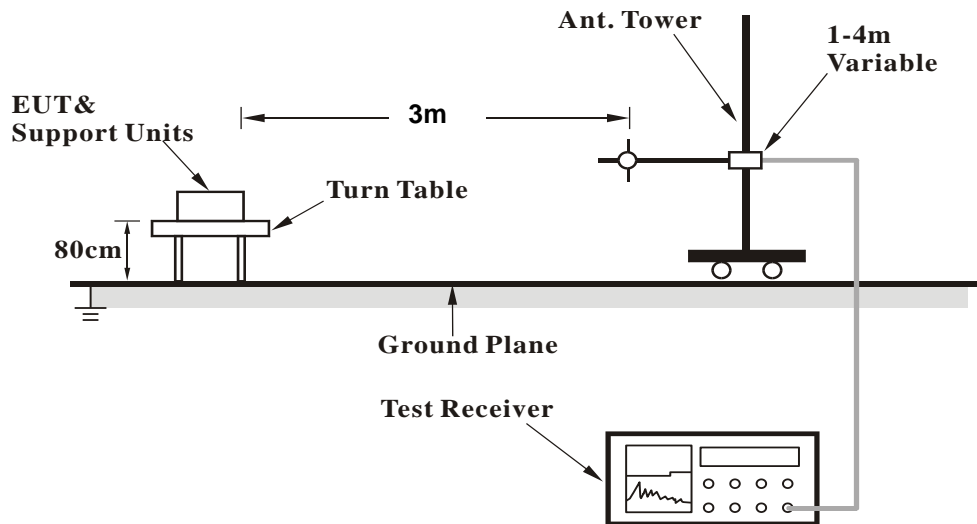

**<Frequency Range above 1 GHz>**

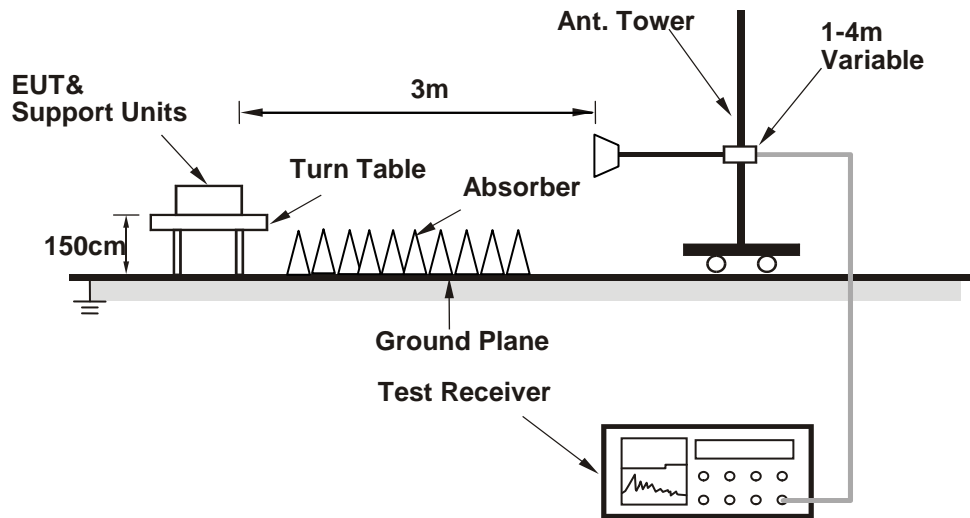

For the actual test configuration, please refer to the attached file (Test Setup Photo).

**4.1.7 EUT Operating Conditions**

- a. Placed the EUT on a testing table.
- b. Use the software to control the EUT under transmission condition continuously at specific channel frequency.

## 4.1.8 Test Results

## Above 1 GHz Data :

## 802.11a

EUT Test Condition		Measurement Detail	
Channel	Channel 36	Frequency Range	1 GHz ~ 40 GHz
Input Power	120 Vac, 60 Hz	Detector Function	Peak (PK) Average (AV)
Environmental Conditions	25 deg. C, 65 % RH	Tested By	Getaz Yang

Antenna Polarity & Test Distance: Horizontal at 3 m										
Frequency (MHz)	Emission Level (dBuV/m)	Read Level (dBuV)	Limit (dBuV/m)	Margin (dB)	Antenna Factor (dB/m)	Cable Loss (dB)	Preamp Factor (dB)	Antenna Height (cm)	Table Angle (Degree)	Remark
5136.62	42.84	42.26	54	-11.16	31.55	6.33	37.3	214	255	Average
5136.62	54.52	53.94	74	-19.48	31.55	6.33	37.3	214	255	Peak
5180	102.09	101.47			31.59	6.37	37.34	214	255	Average
5180	111.38	110.76			31.59	6.37	37.34	214	255	Peak
*10360	58.59	61.35	68.2	-9.61	39.48	10.21	52.45	200	60	Peak
Antenna Polarity & Test Distance: Vertical at 3 m										
Frequency (MHz)	Emission Level (dBuV/m)	Read Level (dBuV)	Limit (dBuV/m)	Margin (dB)	Antenna Factor (dB/m)	Cable Loss (dB)	Preamp Factor (dB)	Antenna Height (cm)	Table Angle (Degree)	Remark
5139.14	41.9	41.32	54	-12.1	31.55	6.33	37.3	194	184	Average
5139.14	53.44	52.86	74	-20.56	31.55	6.33	37.3	194	184	Peak
5180	102.91	102.29			31.59	6.37	37.34	194	184	Average
5180	111.75	111.13			31.59	6.37	37.34	194	184	Peak
*10360	68	70.76	68.2	-0.2	39.48	10.21	52.45	100	101	Peak

## Remarks:

- Emission Level = Read Level + Antenna Factor + Cable Loss - Preamp Factor  
Margin value = Emission level – Limit value
- 5180 MHz: Fundamental Frequency
- \*: Out of Restricted Band

EUT Test Condition		Measurement Detail	
Channel	Channel 44	Frequency Range	1 GHz ~ 40 GHz
Input Power	120 Vac, 60 Hz	Detector Function	Peak (PK) Average (AV)
Environmental Conditions	25 deg. C, 65 % RH	Tested By	Getaz Yang

Antenna Polarity & Test Distance: Horizontal at 3 m										
Frequency (MHz)	Emission Level (dBuV/m)	Read Level (dBuV)	Limit (dBuV/m)	Margin (dB)	Antenna Factor (dB/m)	Cable Loss (dB)	Preamp Factor (dB)	Antenna Height (cm)	Table Angle (Degree)	Remark
5135.72	41.84	41.26	54	-12.16	31.55	6.33	37.3	214	255	Average
5135.72	52.5	51.92	74	-21.5	31.55	6.33	37.3	214	255	Peak
5220	101.33	100.68			31.61	6.4	37.36	214	255	Average
5220	111.21	110.56			31.61	6.4	37.36	214	255	Peak
5375.3	40.94	39.93	54	-13.06	31.72	6.47	37.18	214	255	Average
5375.3	52.17	51.16	74	-21.83	31.72	6.47	37.18	214	255	Peak
*10440	58.37	61.13	68.2	-9.83	39.55	10.21	52.52	200	60	Peak
Antenna Polarity & Test Distance: Vertical at 3 m										
Frequency (MHz)	Emission Level (dBuV/m)	Read Level (dBuV)	Limit (dBuV/m)	Margin (dB)	Antenna Factor (dB/m)	Cable Loss (dB)	Preamp Factor (dB)	Antenna Height (cm)	Table Angle (Degree)	Remark
5144.36	40.12	39.54	54	-13.88	31.55	6.33	37.3	194	184	Average
5144.36	51.99	51.42	74	-22.01	31.56	6.33	37.32	194	184	Peak
5220	102.76	102.11			31.61	6.4	37.36	194	184	Average
5220	111.95	111.3			31.61	6.4	37.36	194	184	Peak
5383.33	40.84	39.83	54	-13.16	31.72	6.47	37.18	194	184	Average
5383.33	52.71	51.69	74	-21.29	31.73	6.47	37.18	194	184	Peak
*10443	67.45	70.21	68.2	-0.75	39.55	10.21	52.52	100	99	Peak

Remarks:

- Emission Level = Read Level + Antenna Factor + Cable Loss - Preamp Factor  
Margin value = Emission level – Limit value
- 5220 MHz: Fundamental Frequency
- \*: Out of Restricted Band

EUT Test Condition		Measurement Detail	
Channel	Channel 48	Frequency Range	1 GHz ~ 40 GHz
Input Power	120 Vac, 60 Hz	Detector Function	Peak (PK) Average (AV)
Environmental Conditions	25 deg. C, 65 % RH	Tested By	Getaz Yang

Antenna Polarity & Test Distance: Horizontal at 3 m										
Frequency (MHz)	Emission Level (dBuV/m)	Read Level (dBuV)	Limit (dBuV/m)	Margin (dB)	Antenna Factor (dB/m)	Cable Loss (dB)	Preamp Factor (dB)	Antenna Height (cm)	Table Angle (Degree)	Remark
5136.44	41.47	40.89	54	-12.53	31.55	6.33	37.3	214	255	Average
5136.44	52.11	51.53	74	-21.89	31.55	6.33	37.3	214	255	Peak
5240	101.27	100.55			31.62	6.42	37.32	214	255	Average
5240	110.9	110.18			31.62	6.42	37.32	214	255	Peak
5436.35	41	39.99	54	-13	31.72	6.47	37.18	214	255	Average
5436.35	52.63	51.5	74	-21.37	31.76	6.5	37.13	214	255	Peak
*10480	58.32	61.16	68.2	-9.88	39.6	10.22	52.66	200	60	Peak
Antenna Polarity & Test Distance: Vertical at 3 m										
Frequency (MHz)	Emission Level (dBuV/m)	Read Level (dBuV)	Limit (dBuV/m)	Margin (dB)	Antenna Factor (dB/m)	Cable Loss (dB)	Preamp Factor (dB)	Antenna Height (cm)	Table Angle (Degree)	Remark
5134.1	39.78	39.2	54	-14.22	31.56	6.34	37.32	194	184	Average
5134.1	52.34	51.77	74	-21.66	31.55	6.32	37.3	194	184	Peak
5240	103.3	102.58			31.62	6.42	37.32	194	184	Average
5240	112.7	111.98			31.62	6.42	37.32	194	184	Peak
5407.53	41.17	40.16	54	-12.83	31.72	6.47	37.18	194	184	Average
5407.53	52.87	51.83	74	-21.13	31.74	6.48	37.18	194	184	Peak
*10480	67.93	70.77	68.2	-0.27	39.6	10.22	52.66	100	93	Peak

Remarks:

- Emission Level = Read Level + Antenna Factor + Cable Loss - Preamp Factor  
Margin value = Emission level – Limit value
- 5240 MHz: Fundamental Frequency
- \*: Out of Restricted Band

EUT Test Condition		Measurement Detail	
Channel	Channel 149	Frequency Range	1 GHz ~ 40 GHz
Input Power	120 Vac, 60 Hz	Detector Function	Peak (PK) Average (AV)
Environmental Conditions	25 deg. C, 65 % RH	Tested By	Getaz Yang

<Spurious Emission>

Antenna Polarity & Test Distance: Horizontal at 3 m										
Frequency (MHz)	Emission Level (dBuV/m)	Read Level (dBuV)	Limit (dBuV/m)	Margin (dB)	Antenna Factor (dB/m)	Cable Loss (dB)	Preamp Factor (dB)	Antenna Height (cm)	Table Angle (Degree)	Remark
5745	95.77	94.25			32.21	6.78	37.47	213	74	Average
5745	105.61	104.09			32.21	6.78	37.47	213	74	Peak
11490	48.23	50.1	54	-5.77	40.25	10.66	52.78	100	164	Average
11490	59.53	61.4	74	-14.47	40.25	10.66	52.78	100	164	Peak
Antenna Polarity & Test Distance: Vertical at 3 m										
Frequency (MHz)	Emission Level (dBuV/m)	Read Level (dBuV)	Limit (dBuV/m)	Margin (dB)	Antenna Factor (dB/m)	Cable Loss (dB)	Preamp Factor (dB)	Antenna Height (cm)	Table Angle (Degree)	Remark
5745	99.22	97.7			32.21	6.78	37.47	218	11	Average
5745	109.64	108.12			32.21	6.78	37.47	218	11	Peak
11490	53.32	55.19	54	-0.68	40.25	10.66	52.78	101	116	Average
11490	65.59	67.46	74	-8.41	40.25	10.66	52.78	101	116	Peak

<Out of Band Emission (OOBE)>

Antenna Polarity & Test Distance: Horizontal at 3 m										
Frequency (MHz)	Emission Level (dBuV/m)	Read Level (dBuV)	Limit (dBuV/m)	Margin (dB)	Antenna Factor (dB/m)	Cable Loss (dB)	Preamp Factor (dB)	Antenna Height (cm)	Table Angle (Degree)	Remark
5627.425	52.54	51.06	68.2	-15.66	32.01	6.69	37.22	213	74	Peak
5656.4	51.29	49.86	72.95	-21.66	32.06	6.71	37.34	213	74	Peak
5917.175	51.95	50.1	73.97	-22.02	32.49	6.86	37.5	213	74	Peak
5964.675	52.53	50.59	68.2	-15.67	32.57	6.88	37.51	213	74	Peak
Antenna Polarity & Test Distance: Vertical at 3 m										
Frequency (MHz)	Emission Level (dBuV/m)	Read Level (dBuV)	Limit (dBuV/m)	Margin (dB)	Antenna Factor (dB/m)	Cable Loss (dB)	Preamp Factor (dB)	Antenna Height (cm)	Table Angle (Degree)	Remark
5614.6	51.98	50.53	68.2	-16.22	31.98	6.69	37.22	218	11	Peak
5651.65	50.67	49.18	69.43	-18.76	32.06	6.71	37.28	218	11	Peak
5921.45	50.83	48.98	70.82	-19.99	32.49	6.86	37.5	218	11	Peak
5955.65	52.3	50.36	68.2	-15.9	32.57	6.87	37.5	218	11	Peak

Remarks:

- Emission Level = Read Level + Antenna Factor + Cable Loss - Preamp Factor  
Margin value = Emission level – Limit value
- 5745 MHz: Fundamental Frequency
- \*: Out of Restricted Band

EUT Test Condition		Measurement Detail	
Channel	Channel 157	Frequency Range	1 GHz ~ 40 GHz
Input Power	120 Vac, 60 Hz	Detector Function	Peak (PK) Average (AV)
Environmental Conditions	25 deg. C, 65 % RH	Tested By	Getaz Yang

<Spurious Emission>

Antenna Polarity & Test Distance: Horizontal at 3 m										
Frequency (MHz)	Emission Level (dBuV/m)	Read Level (dBuV)	Limit (dBuV/m)	Margin (dB)	Antenna Factor (dB/m)	Cable Loss (dB)	Preamp Factor (dB)	Antenna Height (cm)	Table Angle (Degree)	Remark
5785	96.57	95.03			32.26	6.82	37.54	202	74	Average
5785	105.92	104.38			32.26	6.82	37.54	202	74	Peak
11570	48.12	50.24	54	-5.88	40.13	10.76	53.01	100	164	Average
11570	60.59	62.71	74	-13.41	40.13	10.76	53.01	100	164	Peak
Antenna Polarity & Test Distance: Vertical at 3 m										
Frequency (MHz)	Emission Level (dBuV/m)	Read Level (dBuV)	Limit (dBuV/m)	Margin (dB)	Antenna Factor (dB/m)	Cable Loss (dB)	Preamp Factor (dB)	Antenna Height (cm)	Table Angle (Degree)	Remark
5785	99.97	98.43			32.26	6.82	37.54	202	12	Average
5785	108.88	107.34			32.26	6.82	37.54	202	12	Peak
11576	53.3	55.42	54	-0.7	40.13	10.76	53.01	100	115	Average
11576	66.69	68.81	74	-7.31	40.13	10.76	53.01	100	115	Peak

<Out of Band Emission (OOBE)>

Antenna Polarity & Test Distance: Horizontal at 3 m										
Frequency (MHz)	Emission Level (dBuV/m)	Read Level (dBuV)	Limit (dBuV/m)	Margin (dB)	Antenna Factor (dB/m)	Cable Loss (dB)	Preamp Factor (dB)	Antenna Height (cm)	Table Angle (Degree)	Remark
5606.05	51.9	50.46	68.2	-16.3	31.98	6.68	37.22	202	74	Peak
5654.975	50.77	49.34	71.9	-21.13	32.06	6.71	37.34	202	74	Peak
5921.925	51.32	49.44	70.47	-19.15	32.52	6.86	37.5	202	74	Peak
5976.075	52.79	50.82	68.2	-15.41	32.6	6.88	37.51	202	74	Peak
Antenna Polarity & Test Distance: Vertical at 3 m										
Frequency (MHz)	Emission Level (dBuV/m)	Read Level (dBuV)	Limit (dBuV/m)	Margin (dB)	Antenna Factor (dB/m)	Cable Loss (dB)	Preamp Factor (dB)	Antenna Height (cm)	Table Angle (Degree)	Remark
5608.9	52.06	50.62	68.2	-16.14	31.98	6.68	37.22	202	12	Peak
5653.075	50.56	49.07	70.49	-19.93	32.06	6.71	37.28	202	12	Peak
5922.875	51.49	49.61	69.77	-18.28	32.52	6.86	37.5	202	12	Peak
5971.325	52.6	50.66	68.2	-15.6	32.57	6.88	37.51	202	12	Peak

Remarks:

- Emission Level = Read Level + Antenna Factor + Cable Loss - Preamp Factor  
Margin value = Emission level – Limit value
- 5785 MHz: Fundamental Frequency
- \*: Out of Restricted Band

EUT Test Condition		Measurement Detail	
Channel	Channel 165	Frequency Range	1 GHz ~ 40 GHz
Input Power	120 Vac, 60 Hz	Detector Function	Peak (PK) Average (AV)
Environmental Conditions	25 deg. C, 65 % RH	Tested By	Getaz Yang

<Spurious Emission>

Antenna Polarity & Test Distance: Horizontal at 3 m										
Frequency (MHz)	Emission Level (dBuV/m)	Read Level (dBuV)	Limit (dBuV/m)	Margin (dB)	Antenna Factor (dB/m)	Cable Loss (dB)	Preamp Factor (dB)	Antenna Height (cm)	Table Angle (Degree)	Remark
5825	95.01	93.35			32.35	6.84	37.53	201	73	Average
5825	104.78	103.12			32.35	6.84	37.53	201	73	Peak
11650	47.67	49.98	54	-6.33	40.03	10.8	53.14	100	164	Average
11650	59.69	62	74	-14.31	40.03	10.8	53.14	100	164	Peak
Antenna Polarity & Test Distance: Vertical at 3 m										
Frequency (MHz)	Emission Level (dBuV/m)	Read Level (dBuV)	Limit (dBuV/m)	Margin (dB)	Antenna Factor (dB/m)	Cable Loss (dB)	Preamp Factor (dB)	Antenna Height (cm)	Table Angle (Degree)	Remark
5825	98.36	96.7			32.35	6.84	37.53	200	12	Average
5825	107.51	105.85			32.35	6.84	37.53	200	12	Peak
11650	53.69	56	54	-0.31	40.03	10.8	53.14	100	116	Average
11650	64.06	66.37	74	-9.94	40.03	10.8	53.14	100	116	Peak

<Out of Band Emission (OOBE)>

Antenna Polarity & Test Distance: Horizontal at 3 m										
Frequency (MHz)	Emission Level (dBuV/m)	Read Level (dBuV)	Limit (dBuV/m)	Margin (dB)	Antenna Factor (dB/m)	Cable Loss (dB)	Preamp Factor (dB)	Antenna Height (cm)	Table Angle (Degree)	Remark
5626.95	52.35	50.87	68.2	-15.85	32.01	6.69	37.22	201	73	Peak
5654.975	51.19	49.76	71.9	-20.71	32.06	6.71	37.34	201	73	Peak
5920.5	51.79	49.94	71.52	-19.73	32.49	6.86	37.5	201	73	Peak
5996.025	51.84	49.83	68.2	-16.36	32.63	6.89	37.51	201	73	Peak
Antenna Polarity & Test Distance: Vertical at 3 m										
Frequency (MHz)	Emission Level (dBuV/m)	Read Level (dBuV)	Limit (dBuV/m)	Margin (dB)	Antenna Factor (dB/m)	Cable Loss (dB)	Preamp Factor (dB)	Antenna Height (cm)	Table Angle (Degree)	Remark
5572.325	52.03	50.59	68.2	-16.17	31.92	6.64	37.12	200	12	Peak
5654.5	51.03	49.6	71.54	-20.51	32.06	6.71	37.34	200	12	Peak
5924.775	51.47	49.59	68.37	-16.9	32.52	6.86	37.5	200	12	Peak
5958.975	52.5	50.56	68.2	-15.7	32.57	6.87	37.5	200	12	Peak

Remarks:

- Emission Level = Read Level + Antenna Factor + Cable Loss - Preamp Factor  
Margin value = Emission level – Limit value
- 5825 MHz: Fundamental Frequency
- \*: Out of Restricted Band



802.11ac (VHT80)

EUT Test Condition		Measurement Detail	
Channel	Channel 42	Frequency Range	1 GHz ~ 40 GHz
Input Power	120 Vac, 60 Hz	Detector Function	Peak (PK) Average (AV)
Environmental Conditions	25 deg. C, 65 % RH	Tested By	Getaz Yang

**Antenna Polarity & Test Distance: Horizontal at 3 m**

Frequency (MHz)	Emission Level (dBuV/m)	Read Level (dBuV)	Limit (dBuV/m)	Margin (dB)	Antenna Factor (dB/m)	Cable Loss (dB)	Preamp Factor (dB)	Antenna Height (cm)	Table Angle (Degree)	Remark
5145.44	52.83	67.48	54	-1.17	31.32	7.04	53.01	202	350	Average
5145.44	63.42	63.08	74	-10.58	31.32	6.34	37.32	202	350	Peak
5210	97.78	97.37			31.37	6.4	37.36	202	350	Average
5210	106.33	105.92			31.37	6.4	37.36	202	350	Peak
5362.43	41.91	56.07	54	-12.09	31.49	7.18	52.83	202	350	Average
5362.43	52.92	52.14	74	-21.08	31.49	6.47	37.18	202	350	Peak
10420	59.61	62.58	74	-14.39	39.27	10.21	52.45	197	36	Peak

**Antenna Polarity & Test Distance: Vertical at 3 m**

Frequency (MHz)	Emission Level (dBuV/m)	Read Level (dBuV)	Limit (dBuV/m)	Margin (dB)	Antenna Factor (dB/m)	Cable Loss (dB)	Preamp Factor (dB)	Antenna Height (cm)	Table Angle (Degree)	Remark
5134.46	53.76	68.46	54	-0.24	31.31	7.02	53.03	205	20	Average
5134.46	65.74	65.41	74	-8.26	31.31	6.32	37.3	205	20	Peak
5210	100.52	100.11			31.37	6.4	37.36	205	20	Average
5210	109.39	108.98			31.37	6.4	37.36	205	20	Peak
5357.7	43.98	58.15	54	-10.02	31.48	7.18	52.83	205	20	Average
5357.7	56.7	55.93	74	-17.3	31.48	6.47	37.18	205	20	Peak
10420	59.45	62.42	74	-14.55	39.27	10.21	52.45	230	87	Peak

Remarks:

- Emission Level = Read Level + Antenna Factor + Cable Loss - Preamp Factor  
Margin value = Emission level – Limit value
- 5210 MHz: Fundamental Frequency
- \*: Out of Restricted Band

EUT Test Condition		Measurement Detail	
Channel	Channel 155	Frequency Range	1 GHz ~ 40 GHz
Input Power	120 Vac, 60 Hz	Detector Function	Peak (PK) Average (AV)
Environmental Conditions	25 deg. C, 65 % RH	Tested By	Getaz Yang

<Spurious Emission>

Antenna Polarity & Test Distance: Horizontal at 3 m										
Frequency (MHz)	Emission Level (dBuV/m)	Read Level (dBuV)	Limit (dBuV/m)	Margin (dB)	Antenna Factor (dB/m)	Cable Loss (dB)	Preamp Factor (dB)	Antenna Height (cm)	Table Angle (Degree)	Remark
5775	96.49	95.14			32.04	6.81	37.5	191	27	Average
5775	105.13	103.78			32.04	6.81	37.5	191	27	Peak
11550	53.26	55.65	54	-0.74	39.81	10.74	52.94	124	160	Average
11550	62.32	64.71	74	-11.68	39.81	10.74	52.94	124	160	Peak
Antenna Polarity & Test Distance: Vertical at 3 m										
Frequency (MHz)	Emission Level (dBuV/m)	Read Level (dBuV)	Limit (dBuV/m)	Margin (dB)	Antenna Factor (dB/m)	Cable Loss (dB)	Preamp Factor (dB)	Antenna Height (cm)	Table Angle (Degree)	Remark
5775	95.5	94.14			32.04	6.82	37.5	175	257	Average
5775	104.38	103.02			32.04	6.82	37.5	175	257	Peak
11550	48.75	51.44	54	-5.25	39.81	10.74	53.24	166	74	Average
11550	57.75	60.44	74	-16.25	39.81	10.74	53.24	166	74	Peak

<Out of Band Emission (OOBE)>

Antenna Polarity & Test Distance: Horizontal at 3 m										
Frequency (MHz)	Emission Level (dBuV/m)	Read Level (dBuV)	Limit (dBuV/m)	Margin (dB)	Antenna Factor (dB/m)	Cable Loss (dB)	Preamp Factor (dB)	Antenna Height (cm)	Table Angle (Degree)	Remark
5649.275	53.53	52.37	68.2	-14.67	31.82	6.62	37.28	191	27	Peak
5650.7	53.8	52.61	68.72	-14.92	31.85	6.62	37.28	191	27	Peak
5923.35	50.85	49.05	69.42	-18.57	32.29	7.01	37.5	191	27	Peak
5963.725	52.97	51.06	68.2	-15.23	32.34	7.08	37.51	191	27	Peak
Antenna Polarity & Test Distance: Vertical at 3 m										
Frequency (MHz)	Emission Level (dBuV/m)	Read Level (dBuV)	Limit (dBuV/m)	Margin (dB)	Antenna Factor (dB/m)	Cable Loss (dB)	Preamp Factor (dB)	Antenna Height (cm)	Table Angle (Degree)	Remark
5636.925	53.69	52.59	68.2	-14.51	31.82	6.56	37.28	175	257	Peak
5651.65	51.62	50.43	69.43	-17.81	31.85	6.62	37.28	175	257	Peak
5921.925	51.4	49.6	70.47	-19.07	32.29	7.01	37.5	175	257	Peak
5931.425	52.89	51.09	68.2	-15.31	32.29	7.01	37.5	175	257	Peak

Remarks:

- Emission Level = Read Level + Antenna Factor + Cable Loss - Preamp Factor  
Margin value = Emission level – Limit value
- 5775 MHz: Fundamental Frequency
- \*: Out of Restricted Band

**9 kHz ~ 30 MHz Data:**

The amplitude of spurious emissions attenuated more than 20 dB below the permissible value is not required to be report.

**30 MHz ~ 1 GHz Worst-Case Data:**

**802.11a**

EUT Test Condition		Measurement Detail	
Channel	Channel 36	Frequency Range	30 MHz ~ 1 GHz
Input Power	120 Vac, 60 Hz	Detector Function	Peak (PK) Quasi-peak (QP)
Environmental Conditions	25 deg. C, 65 % RH	Tested By	Gavin Wu

Antenna Polarity & Test Distance: Horizontal at 3 m										
Frequency (MHz)	Emission Level (dBuV/m)	Read Level (dBuV)	Limit (dBuV/m)	Margin (dB)	Antenna Factor (dB/m)	Cable Loss (dB)	Preamp Factor (dB)	Antenna Height (cm)	Table Angle (Degree)	Remark
67.83	38.12	58.22	40	-1.88	11	0.63	31.73	137	233	QP
162.89	29	47.36	43.5	-14.5	12.44	1.03	31.83	112	6	Peak
375.32	42.55	57.75	46	-3.45	14.75	1.99	31.94	128	49	Peak
542.16	31.34	42.16	46	-14.66	18.28	2.67	31.77	139	169	Peak
625.58	31.57	40.79	46	-14.43	19.92	3.01	32.15	126	138	Peak
768.17	42.27	48.25	46	-3.73	21.78	3.57	31.33	132	112	Peak
Antenna Polarity & Test Distance: Vertical at 3 m										
Frequency (MHz)	Emission Level (dBuV/m)	Read Level (dBuV)	Limit (dBuV/m)	Margin (dB)	Antenna Factor (dB/m)	Cable Loss (dB)	Preamp Factor (dB)	Antenna Height (cm)	Table Angle (Degree)	Remark
67.83	34.08	54.18	40	-5.92	11	0.63	31.73	124	238	Peak
260.86	37.08	55.67	46	-8.92	11.79	1.49	31.87	100	201	Peak
384.05	40.69	55.7	46	-5.31	14.96	2.02	31.99	126	180	Peak
547.01	37.66	48.46	46	-8.34	18.39	2.69	31.88	114	91	Peak
625.58	39.36	48.58	46	-6.64	19.92	3.01	32.15	128	81	Peak
768.17	36.97	42.95	46	-9.03	21.78	3.57	31.33	121	199	Peak

Remarks:

- Emission Level = Read Level + Antenna Factor + Cable Loss - Preamp Factor  
Margin value = Emission level – Limit value

## 4.2 Conducted Emission Measurement

### 4.2.1 Limits of Conducted Emission Measurement

Frequency (MHz)	Conducted Limit (dBuV)	
	Quasi-peak	Average
0.15 - 0.5	66 - 56	56 - 46
0.50 - 5.0	56	46
5.0 - 30.0	60	50

- Note: 1. The lower limit shall apply at the transition frequencies.  
 2. The limit decreases in line with the logarithm of the frequency in the range of 0.15 to 0.50 MHz.

### 4.2.2 Test Instruments

Description & Manufacturer	Model No.	Serial No.	Date Of Calibration	Due Date Of Calibration
Test Receiver ROHDE & SCHWARZ	ESCS 30	100288	Aug. 17, 2017	Aug. 16, 2018
RF signal cable (with 10dB PAD) Woken	5D-FB	Cable-cond1-01	Sep. 05, 2017	Sep. 04, 2018
LISN/AMN ROHDE & SCHWARZ (EUT)	ESH3-Z5	835239/001	Mar. 10, 2017	Mar. 09, 2018
LISN/AMN ROHDE & SCHWARZ (Peripheral)	ENV216	101196	Apr. 20, 2017	Apr. 19, 2018
Software ADT	BV ADT_Cond_ V7.3.7.3	NA	NA	NA

- Note: 1. The calibration interval of the above test instruments is 12 months and the calibrations are traceable to NML/ROC and NIST/USA.  
 2. The test was performed in HwaYa Shielded Room 1.  
 3. The VCCI Site Registration No. is C-2040.

#### 4.2.3 Test Procedures

- a. The EUT was placed 0.4 meters from the conducting wall of the shielded room with EUT being connected to the power mains through a line impedance stabilization network (LISN). Other support units were connected to the power mains through another LISN. The two LISNs provide 50 ohm/ 50uH of coupling impedance for the measuring instrument.
- b. Both lines of the power mains connected to the EUT were checked for maximum conducted interference.
- c. The frequency range from 150 kHz to 30 MHz was searched. Emission levels under (Limit -20 dB) was not recorded.

**Note:** All modes of operation were investigated and the worst-case emissions are reported.

#### 4.2.4 Deviation from Test Standard

No deviation.

#### 4.2.5 Test Setup

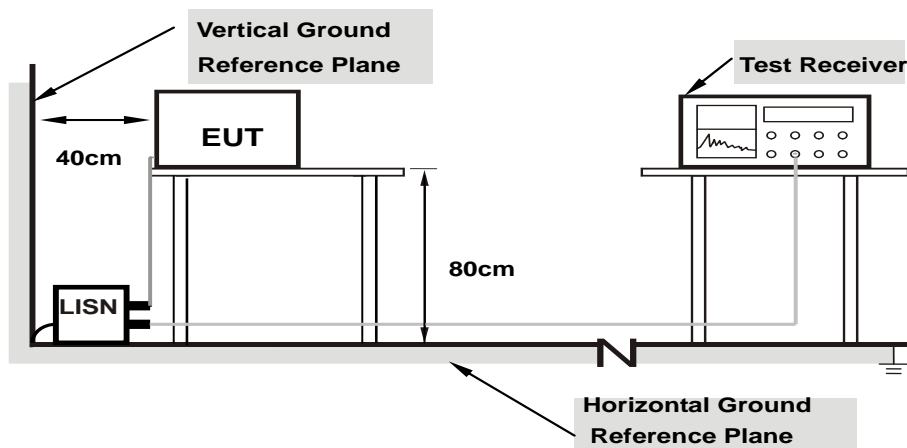

- Note:**
1. Support units were connected to second LISN.
  2. Both of LISNs (AMN) are 80 cm from EUT and at least 80 from other units and other metal planes

For the actual test configuration, please refer to the attached file (Test Setup Photo).

#### 4.2.6 EUT Operating Conditions

- a. Placed the EUT on a testing table.
- b. Use the software to control the EUT under transmission condition continuously at specific channel frequency.

#### 4.2.7 Test Results

Frequency Range	150kHz ~ 30MHz	Detector Function & Resolution Bandwidth	Quasi-Peak (QP) / Average (AV), 9kHz
Input Power	120Vac, 60Hz	Environmental Conditions	25°C, 65%RH
Tested by	Getaz Yang	Test Date	2017/11/22

Phase Of Power : Line (L)										
No	Frequency (MHz)	Correction Factor (dB)	Reading Value (dBuV)		Emission Level (dBuV)		Limit (dBuV)		Margin (dB)	
			Q.P.	AV.	Q.P.	AV.	Q.P.	AV.	Q.P.	AV.
1	0.17000	10.39	32.01	16.37	42.40	26.76	64.96	54.96	-22.56	-28.20
2	0.19013	10.39	28.37	14.50	38.76	24.89	64.03	54.03	-25.27	-29.14
3	0.40200	10.41	23.68	19.71	34.09	30.12	57.81	47.81	-23.72	-17.69
4	1.52600	10.44	14.05	6.44	24.49	16.88	56.00	46.00	-31.51	-29.12
5	2.49000	10.49	16.74	7.81	27.23	18.30	56.00	46.00	-28.77	-27.70
6	14.54600	11.08	13.64	7.33	24.72	18.41	60.00	50.00	-35.28	-31.59

Remarks:

1. Q.P. and AV. are abbreviations of quasi-peak and average individually.
2. The emission levels of other frequencies were very low against the limit.
3. Margin value = Emission level – Limit value
4. Correction factor = Insertion loss + Cable loss
5. Emission Level = Correction Factor + Reading Value

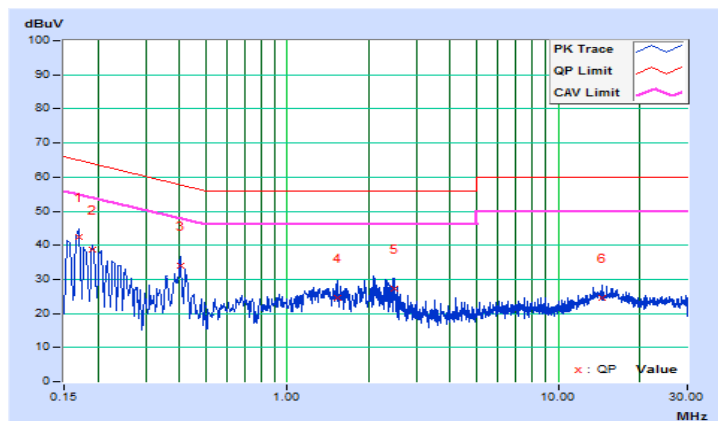

Frequency Range	150kHz ~ 30MHz	Detector Function & Resolution Bandwidth	Quasi-Peak (QP) / Average (AV), 9kHz
Input Power	120Vac, 60Hz	Environmental Conditions	25°C, 65%RH
Tested by	Getaz Yang	Test Date	2017/11/22

Phase Of Power : Neutral (N)										
No	Frequency (MHz)	Correction Factor (dB)	Reading Value (dBuV)		Emission Level (dBuV)		Limit (dBuV)		Margin (dB)	
			Q.P.	AV.	Q.P.	AV.	Q.P.	AV.	Q.P.	AV.
1	0.15400	10.15	31.20	17.46	41.35	27.61	65.78	55.78	-24.43	-28.17
2	0.17400	10.16	27.69	15.04	37.85	25.20	64.77	54.77	-26.92	-29.57
3	0.19832	10.16	24.01	11.61	34.17	21.77	63.68	53.68	-29.51	-31.91
<b>4</b>	<b>0.40605</b>	<b>10.17</b>	<b>23.24</b>	<b>21.60</b>	<b>33.41</b>	<b>31.77</b>	<b>57.73</b>	<b>47.73</b>	<b>-24.32</b>	<b>-15.96</b>
5	2.46200	10.26	16.72	6.76	26.98	17.02	56.00	46.00	-29.02	-28.98
6	14.58600	10.76	12.35	6.28	23.11	17.04	60.00	50.00	-36.89	-32.96

Remarks:

1. Q.P. and AV. are abbreviations of quasi-peak and average individually.
2. The emission levels of other frequencies were very low against the limit.
3. Margin value = Emission level – Limit value
4. Correction factor = Insertion loss + Cable loss
5. Emission Level = Correction Factor + Reading Value

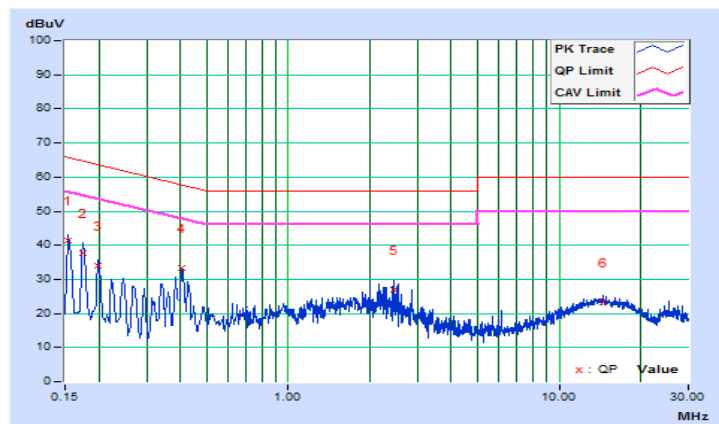

### 4.3 Transmit Power Measurement

#### 4.3.1 Limits of Transmit Power Measurement

Operation Band	EUT Category		Limit
U-NII-1		Outdoor Access Point	1 Watt (30 dBm) (Max. e.i.r.p $\leq$ 125 mW (21 dBm) at any elevation angle above 30 degrees as measured from the horizon)
		Fixed point-to-point Access Point	1 Watt (30 dBm)
	√	Indoor Access Point	1 Watt (30 dBm)
		Mobile and Portable client device	250 mW (24 dBm)
U-NII-2A			250 mW (24 dBm) or 11 dBm + 10 log B*
U-NII-2C			250 mW (24 dBm) or 11 dBm + 10 log B*
U-NII-3	√		1 Watt (30 dBm)

\*B is the 26 dB emission bandwidth in megahertz

Per KDB 662911 Method of conducted output power measurement on IEEE 802.11 devices,

Array Gain = 0 dB (i.e., no array gain) for  $N_{ANT} \leq 4$ ;

Array Gain = 0 dB (i.e., no array gain) for channel widths  $\geq 40$  MHz for any  $N_{ANT}$ ;

Array Gain =  $5 \log(N_{ANT}/N_{SS})$  dB or 3 dB, whichever is less for 20 MHz channel widths with  $N_{ANT} \geq 5$ .

For power measurements on all other devices: Array Gain =  $10 \log(N_{ANT}/N_{SS})$  dB.

#### 4.3.2 Test Setup

##### <Power Output Measurement>

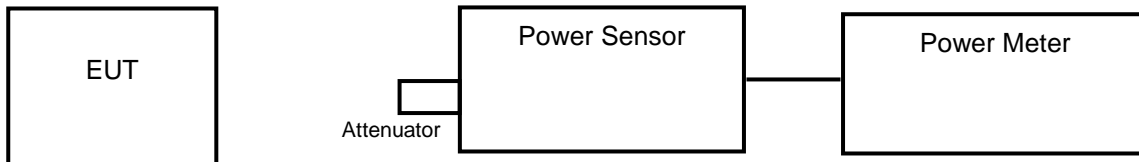

or

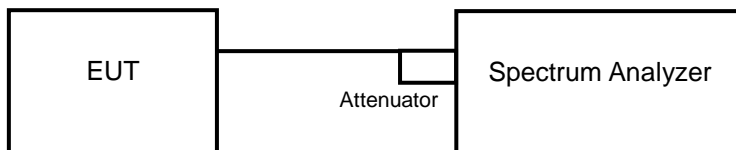

##### <26 dB Bandwidth>

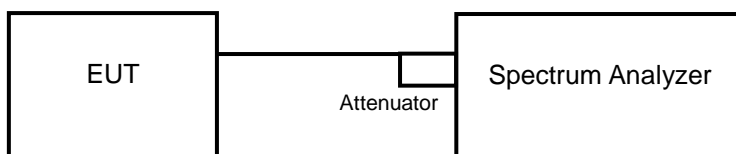



#### 4.3.3 Test Instruments

Refer to section 4.1.2 to get information of above instrument.

#### 4.3.4 Test Procedure

##### **Average Power Measurement**

<802.11a>

Method PM is used to perform output power measurement, trigger and gating function of wide band power meter is enabled to measure max output power of TX on burst. Duty factor is not added to measured value.

<802.11ac (VHT80)>

Method SA-1 is used to perform output power measurement, trigger and gating function of spectrum analyzer is enabled to measure max output power of TX on burst. Duty factor is not added to measured value.

##### **26 dB Bandwidth**

- 1) Set RBW = approximately 1 % of the emission bandwidth.
- 2) Set the VBW > RBW.
- 3) Detector = Peak.
- 4) Trace mode = max hold.
- 5) Measure the maximum width of the emission that is 26 dB down from the peak of the emission. Compare this with the RBW setting of the analyzer. Readjust RBW and repeat measurement as needed until the RBW/EBW ratio is approximately 1 %.

#### 4.3.5 Deviation from Test Standard

No deviation.

#### 4.3.6 EUT Operating Conditions

The software provided by client to enable the EUT under transmission condition continuously at lowest, middle and highest channel frequencies individually.

#### 4.3.7 Test Result

##### Power Output:

##### 802.11a

Channel	Frequency (MHz)	Maximum Conducted Power (dBm)			Total Power (mW)	Total Power (dBm)	Power Limit (dBm)	Pass / Fail
		Chain 0	Chain 1	Chain 2				
36	5180	16.54	15.65	15.93	120.984	20.83	24.06	Pass
44	5220	16.67	15.44	15.27	115.098	20.61	24.02	Pass
48	5240	16.64	15.37	15.26	114.141	20.57	24.03	Pass
149	5745	10.43	9.75	14.82	50.821	17.06	30	Pass
157	5785	10.73	10.36	10.11	32.951	15.18	30	Pass
165	5825	9.37	8.54	8.26	22.494	13.52	30	Pass

##### Note:

##### For U-NII-2A, U-NII-2C Band:

##### Chain 0

1.  $11 \text{ dBm} + 10\log(20.08) = 24.03\text{dBm} < 30 \text{ dBm}$ .
2.  $11 \text{ dBm} + 10\log(20.03) = 24.02\text{dBm} < 30 \text{ dBm}$ .
3.  $11 \text{ dBm} + 10\log(19.93) = 24.00\text{dBm} < 30 \text{ dBm}$ .

##### Chain 1

1.  $11 \text{ dBm} + 10\log(19.46) = 23.89\text{dBm} < 30 \text{ dBm}$ .
2.  $11 \text{ dBm} + 10\log(19.57) = 23.92\text{dBm} < 30 \text{ dBm}$ .
3.  $11 \text{ dBm} + 10\log(19.77) = 23.96\text{dBm} < 30 \text{ dBm}$ .

##### Chain 2

1.  $11 \text{ dBm} + 10\log(20.25) = 24.06\text{dBm} < 30 \text{ dBm}$ .
2.  $11 \text{ dBm} + 10\log(20.03) = 24.02\text{dBm} < 30 \text{ dBm}$ .
3.  $11 \text{ dBm} + 10\log(20.07) = 24.03\text{dBm} < 30 \text{ dBm}$ .

##### 802.11ac (VHT80)

Channel	Frequency (MHz)	Maximum Conducted Power (dBm)			Total Power (mW)	Total Power (dBm)	Power Limit (dBm)	Pass / Fail
		Chain 0	Chain 1	Chain 2				
42	5210	17.50	17.55	18.03	176.652	22.47	30	Pass
155	5775	15.82	14.16	16.01	104.158	20.18	30	Pass

##### Note:

##### For U-NII-2A, U-NII-2C Band:

##### Chain 0

1.  $11 \text{ dBm} + 10\log(83.82) = 30.23 \text{ dBm} > 30 \text{ dBm}$ .

##### Chain 1

1.  $11 \text{ dBm} + 10\log(83.70) = 30.23 \text{ dBm} > 30 \text{ dBm}$ .

##### Chain 2

1.  $11 \text{ dBm} + 10\log(83.72) = 30.23 \text{ dBm} > 30 \text{ dBm}$ .

**26 dB Bandwidth:**

**802.11a**

Channel	Frequency (MHz)	26 dBc Bandwidth (MHz)		
		Chain 0	Chain 1	Chain 2
36	5180	20.08	19.46	20.25
44	5220	20.03	19.57	20.03
48	5240	19.93	19.77	20.07

**802.11ac (VHT80)**

Channel	Frequency (MHz)	26 dBc Bandwidth (MHz)		
		Chain 0	Chain 1	Chain 2
42	5210	83.82	83.70	83.72

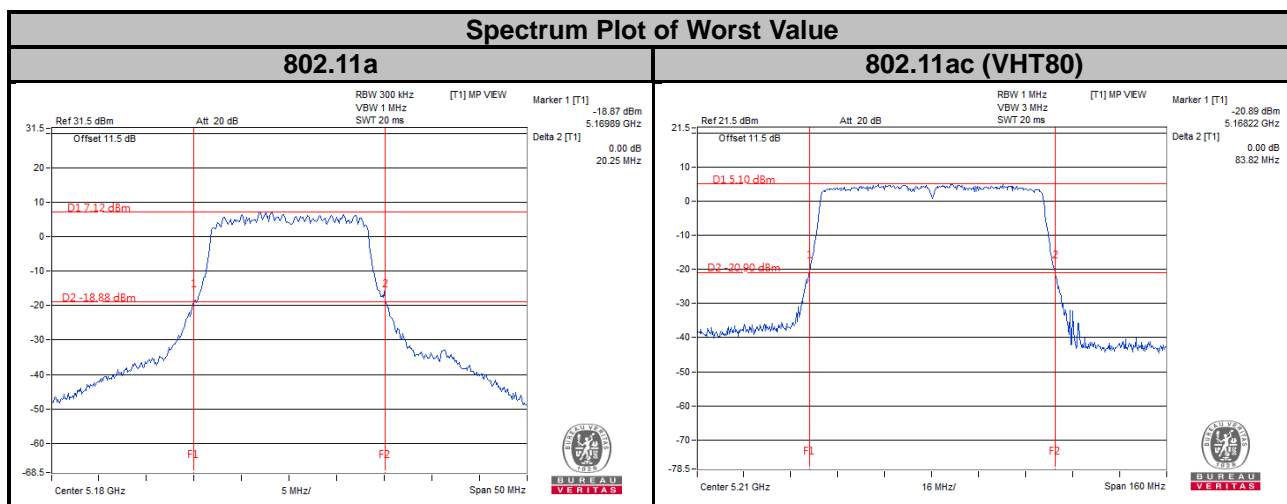

## 4.4 Occupied Bandwidth Measurement

### 4.4.1 Test Setup



### 4.4.2 Test Instruments

Refer to section 4.1.2 to get information of above instrument.

### 4.4.3 Test Procedure

The transmitter output was connected to the spectrum analyzer through an attenuator. The bandwidth of the fundamental frequency was measured by spectrum analyzer with resolution bandwidth in the range of 1 % to 5 % of the anticipated emission bandwidth, and a video bandwidth at least 3x the resolution bandwidth and set the detector to SAMPLE. The width of a frequency band such that, below the lower and above the upper frequency limits, the mean powers emitted are each equal to a specified percentage 0.5 % of the total mean power of a given emission.

#### 4.4.4 Test Results

##### 802.11a

Channel	Channel Frequency (MHz)	Occupied Bandwidth (MHz)		
		Chain 0	Chain 1	Chain 2
36	5180	16.56	16.50	16.50
40	5200	16.56	16.50	16.56
48	5240	16.56	16.44	16.56
149	5745	16.50	16.50	16.50
157	5785	16.55	16.55	16.50
165	5825	16.55	16.50	16.55

##### 802.11ac (VHT80)

Channel	Channel Frequency (MHz)	Occupied Bandwidth (MHz)		
		Chain 0	Chain 1	Chain 2
42	5210	75.96	75.96	75.96
155	5775	75.80	75.96	76.28

#### Spectrum Plot of Worst Value

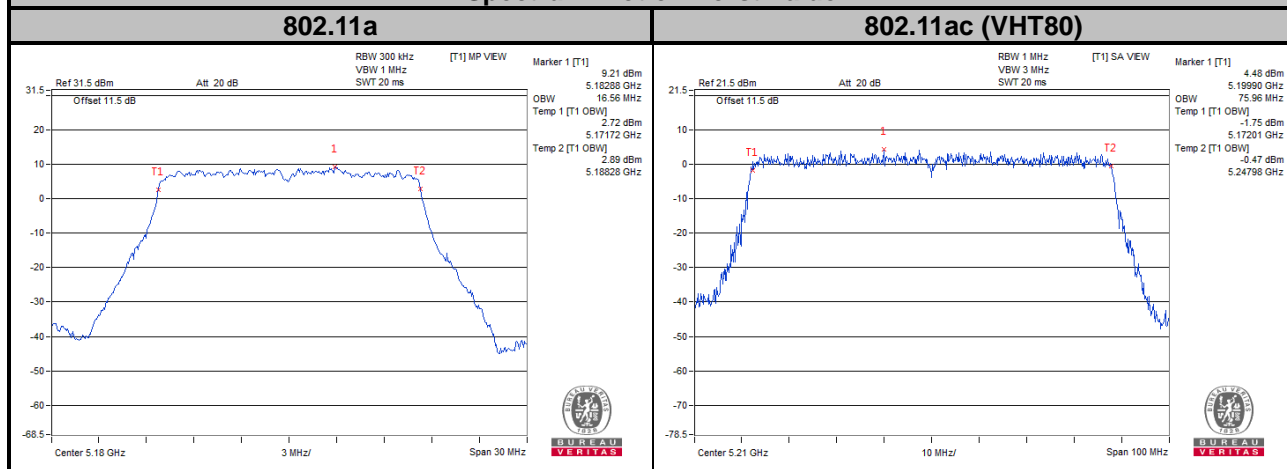

## 4.5 Peak Power Spectral Density Measurement

### 4.5.1 Limits of Peak Power Spectral Density Measurement

Operation Band	EUT Category		Limit
U-NII-1		Outdoor Access Point	17 dBm/MHz
		Fixed point-to-point Access Point	
	√	Indoor Access Point	
		Mobile and Portable client device	11 dBm/MHz
U-NII-2A			11 dBm/MHz
U-NII-2C			11 dBm/MHz
U-NII-3		√	30 dBm/500 kHz

### 4.5.2 Test Setup

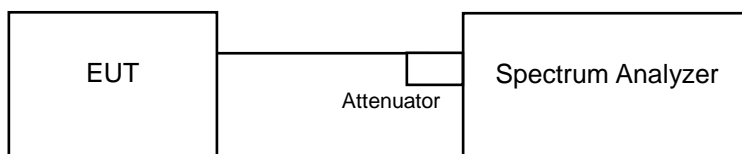

### 4.5.3 Test Instruments

Refer to section 4.1.3 to get information of above instrument.

### 4.5.4 Test Procedures

#### For U-NII-1 band:

Using method SA-2

1. Set span to encompass the entire emission bandwidth (EBW) of the signal.
2. Set RBW = 1 MHz, Set VBW  $\geq$  3 RBW, Detector = RMS
3. Sweep time = auto, trigger set to "free run".
4. Trace average at least 100 traces in power averaging mode.
5. Record the max value and add 10 log (1/duty cycle)

#### ※For U-NII-3:

1. Set span to encompass the entire emission bandwidth (EBW) of the signal.
2. Set RBW = 500 kHz, Set VBW  $\geq$  3 RBW, Detector = RMS
3. Use the peak marker function to determine the maximum power level in any 500 kHz band segment within the fundamental EBW.
4. Sweep time = auto, trigger set to "free run".
5. Trace average at least 100 traces in power averaging mode.
6. Record the max value and add 10 log (1/duty cycle)

#### 4.5.5 Deviation from Test Standard

No deviation.

#### 4.5.6 EUT Operating Conditions

The software provided by client to enable the EUT under transmission condition continuously at lowest, middle and highest channel frequencies individually.

#### 4.5.7 Test Results

##### 802.11a

Channel	Frequency (MHz)	PSD (dBm/MHz)			Duty Factor (dB)	Total PSD with Duty Factor (dBm/MHz)	Max. Limit (dBm/MHz)	Pass / Fail
		Chain 0	Chain 1	Chain 2				
36	5180	5.51	4.70	2.45	0.15	9.32	14.61	Pass
44	5220	5.95	4.32	2.27	0.15	9.35	14.61	Pass
48	5240	5.95	3.82	2.13	0.15	9.16	14.61	Pass

##### Note:

- Method 1 of power density measurement of KDB 662911 is using for calculating total power density. Total power density is summing entire spectra across corresponding frequency bins on the various outputs by computer.
- For U-NII-1 Band:**  
 Directional gain =  $3.62 \text{ dBi} + 10\log(3) = 8.39 \text{ dBi} > 6 \text{ dBi}$  , so the power density limit shall be reduced to  $17 - (8.39 - 6) = 14.61 \text{ dBm}$ .
- Refer to section 3.3 for duty cycle spectrum plot.

**802.11ac (VHT80)**

Channel	Frequency (MHz)	PSD (dBm/MHz)			Duty Factor (dB)	Total PSD with Duty Factor (dBm/MHz)	Max. Limit (dBm/MHz)	Pass / Fail
		Chain 0	Chain 1	Chain 2				
42	5210	-5.70	-3.22	-2.78	0.27	1.32	14.61	Pass

**Note:**

- Method 1 of power density measurement of KDB 662911 is using for calculating total power density. Total power density is summing entire spectra across corresponding frequency bins on the various outputs by computer.
- For U-NII-1 Band:**  
 Directional gain = 3.62 dBi + 10log(3) = 8.39 dBi > 6 dBi , so the power density limit shall be reduced to 17-(8.39-6) = 14.61 dBm.
- Refer to section 3.3 for duty cycle spectrum plot.

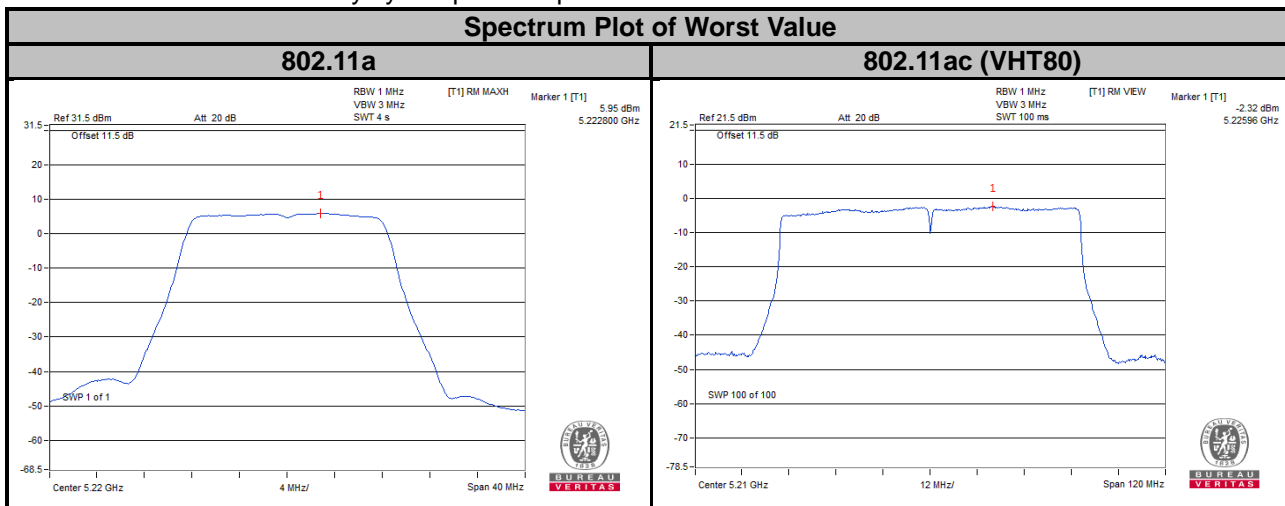



## For U-NII-3 Band

### 802.11a

TX Chain	Channel	Frequency (MHz)	PSD (dBm/500 kHz)	10 log (N=3) dB	Duty Factor (dB)	Total PSD with Duty Factor (dBm/500 kHz)	Limit (dBm/500 kHz)	Pass / Fail
0	149	5745	-5.82	4.77	0.15	-0.90	26.02	Pass
	157	5785	-5.80	4.77	0.15	-0.88	26.02	Pass
	165	5825	-7.73	4.77	0.15	-2.81	26.02	Pass
1	149	5745	-8.36	4.77	0.15	-3.44	26.02	Pass
	157	5785	-7.42	4.77	0.15	-2.50	26.02	Pass
	165	5825	-7.58	4.77	0.15	-2.66	26.02	Pass
2	149	5745	-8.24	4.77	0.15	-3.32	26.02	Pass
	157	5785	-6.99	4.77	0.15	-2.07	26.02	Pass
	165	5825	-8.00	4.77	0.15	-3.08	26.02	Pass

#### Note:

- Method 1 of power density measurement of KDB 662911 is using for calculating total power density. Total power density is summing entire spectra across corresponding frequency bins on the various outputs by computer.
- Directional gain =  $5.21 \text{ dBi} + 10\log(3) = 9.98 \text{ dBi} > 6 \text{ dBi}$  , so the power density limit shall be reduced to  $30 - (9.98 - 6) = 26.02 \text{ dBm}$ .
- Refer to section 3.3 for duty cycle spectrum plot.

### 802.11ac (VHT80)

TX Chain	Channel	Frequency (MHz)	PSD (dBm/300 kHz)	PSD (dBm/500 kHz)	10 log (N=3) dB	Duty Factor (dB)	Total PSD with Duty Factor (dBm/500 kHz)	Limit (dBm/500 kHz)	Pass / Fail
0	155	5775	-10.05	-7.83	4.77	0.15	-2.79	26.02	Pass
1	155	5775	-6.29	-4.07	4.77	0.15	0.97	26.02	Pass
2	155	5775	-6.13	-3.91	4.77	0.15	1.13	26.02	Pass

**Note:**

- Method 1 of power density measurement of KDB 662911 is using for calculating total power density. Total power density is summing entire spectra across corresponding frequency bins on the various outputs by computer.
- Directional gain = 5.21 dBi + 10log(3) = 9.98 dBi > 6 dBi , so the power density limit shall be reduced to 30-(9.98-6) = 26.02 dBm.
- Refer to section 3.3 for duty cycle spectrum plot.

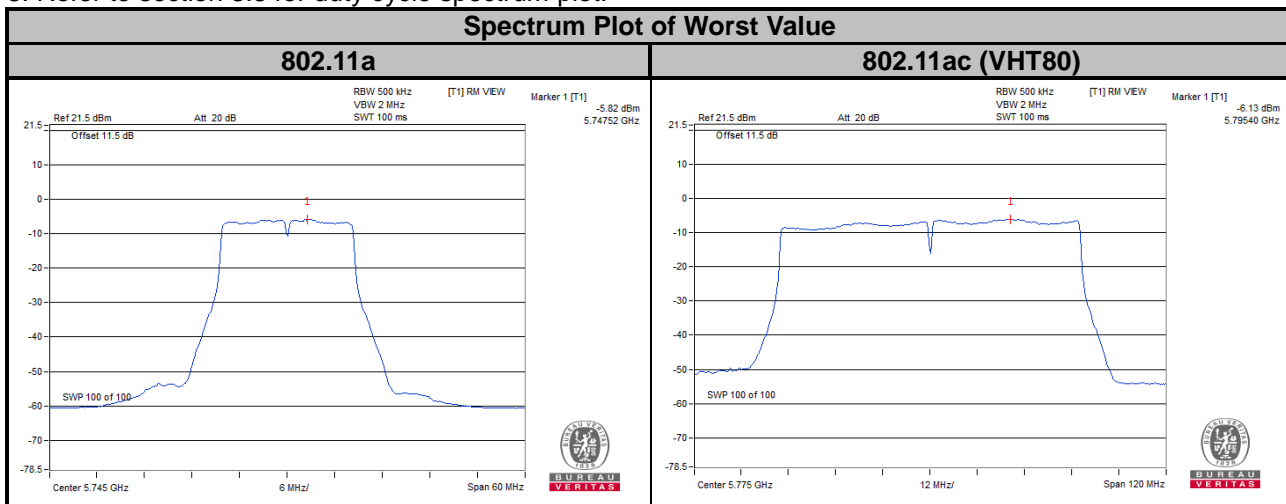

## 4.6 Frequency Stability

### 4.6.1 Limit of Frequency Stability Measurement

The frequency of the carrier signal shall be maintained within band of operation.

### 4.6.2 Test Setup

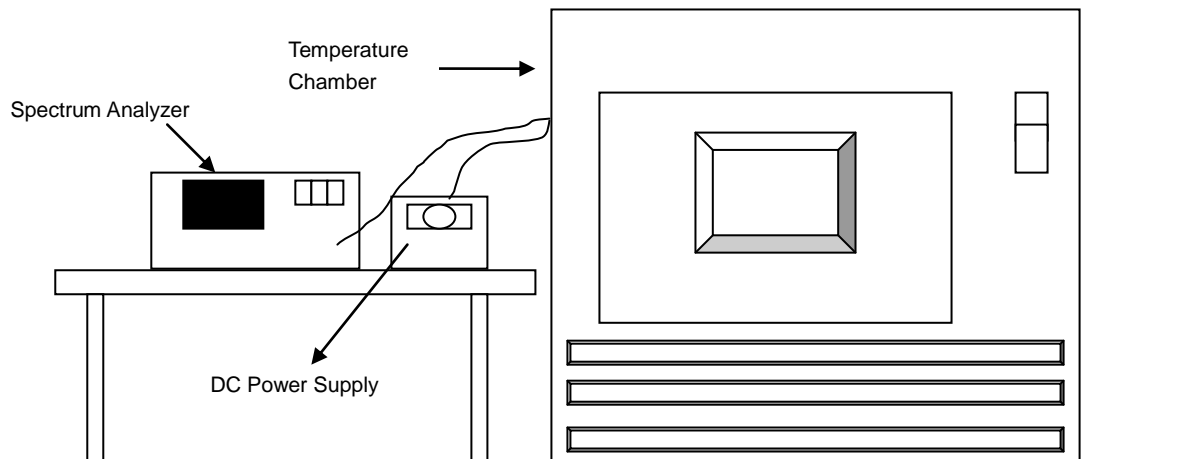

### 4.6.3 Test Instruments

Refer to section 4.1.3 to get information of above instrument.

### 4.6.4 Test Procedure

- To ensure emission at the band edge is maintained within the authorized band, those values shall be measured by radiation emissions at upper and lower frequency points, and finally compensated by frequency deviation as procedures below.
- The EUT was operated at the maximum output power, and connected to the spectrum analyzer, which is set to maximum hold function and peak detector. The peak value of the power envelope was measured and noted. The upper and lower frequency points were respectively measured relatively 10 dB lower than the measured peak value.
- The frequency deviation was calculated by adding the upper frequency point and the lower frequency point divided by two. Those detailed values of frequency deviation are provided in table below.

### 4.6.5 Deviation from Test Standard

No deviation.

### 4.6.6 EUT Operating Condition

Set the EUT transmit at un-modulation mode to test frequency stability.

## 4.6.7 Test Results

Frequency Stability Versus Temp.									
Operating Frequency: 5210 MHz									
Temp. (°C)	Power Supply (Vac)	0 Minute		2 Minute		5 Minute		10 Minute	
		Measured Frequency (MHz)	Frequency Drift (ppm)	Measured Frequency (MHz)	Frequency Drift (ppm)	Measured Frequency (MHz)	Frequency Drift (ppm)	Measured Frequency (MHz)	Frequency Drift (ppm)
50	120	5210.0067	1.29000	5210.0051	0.98000	5210.004	0.77000	5210.0029	0.56000
40	120	5209.9893	-2.05000	5209.9897	-1.98000	5209.9901	-1.90000	5209.9893	-2.05000
30	120	5210.0227	4.36000	5210.0212	4.07000	5210.0219	4.20000	5210.0218	4.18000
20	120	5209.9783	-4.17000	5209.9765	-4.51000	5209.9792	-3.99000	5209.9766	-4.49000
10	120	5209.9767	-4.47000	5209.9776	-4.30000	5209.977	-4.41000	5209.9816	-3.53000
0	120	5210.0123	2.36000	5210.0154	2.96000	5210.0148	2.84000	5210.0159	3.05000
-10	120	5210.0204	3.92000	5210.0219	4.20000	5210.0211	4.05000	5210.0188	3.61000
-20	120	5210.0124	2.38000	5210.0123	2.36000	5210.0131	2.51000	5210.0164	3.15000
-30	120	5209.9916	-1.61000	5209.9907	-1.79000	5209.9954	-0.88000	5209.9945	-1.06000

Frequency Stability Versus Temp.									
Operating Frequency: 5180 MHz									
Temp. (°C)	Power Supply (Vdc)	0 Minute		2 Minute		5 Minute		10 Minute	
		Measured Frequency (MHz)	Frequency Drift (ppm)	Measured Frequency (MHz)	Frequency Drift (ppm)	Measured Frequency (MHz)	Frequency Drift (ppm)	Measured Frequency (MHz)	Frequency Drift (ppm)
20	138	5209.9783	-4.17000	5209.9763	-4.55000	5209.9795	-3.93000	5209.977	-4.41000
	120	5209.9783	-4.17000	5209.9765	-4.51000	5209.9792	-3.99000	5209.9766	-4.49000
	102	5209.9791	-4.01000	5209.9763	-4.55000	5209.9793	-3.97000	5209.9763	-4.55000

## 4.7 6 dB Bandwidth Measurement

### 4.7.1 Limits of 6 dB Bandwidth Measurement

The minimum of 6 dB Bandwidth Measurement is 0.5 MHz.

### 4.7.2 Test Setup

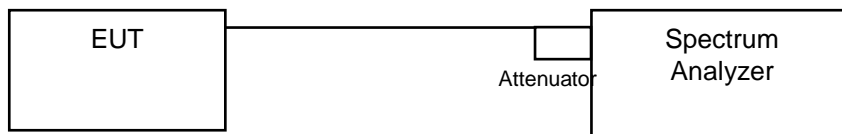

### 4.7.3 Test Instruments

Refer to section 4.1.3 to get information of above instrument.

### 4.7.4 Test Procedure

#### MEASUREMENT PROCEDURE REF

- Set resolution bandwidth (RBW) = 100 kHz
- Set the video bandwidth (VBW)  $\geq 3 \times$  RBW, Detector = Peak.
- Trace mode = max hold.
- Sweep = auto couple.
- Measure the maximum width of the emission that is constrained by the frequencies associated with the two amplitude points (upper and lower) that are attenuated by 6 dB relative to the maximum level measured in the fundamental emission

### 4.7.5 Deviation from Test Standard

No deviation.

### 4.7.6 EUT Operating Condition

The software provided by client to enable the EUT under transmission condition continuously at lowest, middle and highest channel frequencies individually.

#### 4.7.7 Test Results

##### 802.11a

Channel	Frequency (MHz)	6 dB Bandwidth (MHz)			Minimum Limit (MHz)	Pass / Fail
		Chain 0	Chain 1	Chain 2		
149	5745	16.39	16.35	16.41	0.5	Pass
157	5785	16.36	16.32	16.37	0.5	Pass
165	5825	16.30	16.06	16.37	0.5	Pass

##### 802.11ac (VHT80)

Channel	Frequency (MHz)	6 dB Bandwidth (MHz)			Minimum Limit (MHz)	Pass / Fail
		Chain 0	Chain 1	Chain 2		
155	5775	76.21	76.60	76.10	0.5	Pass

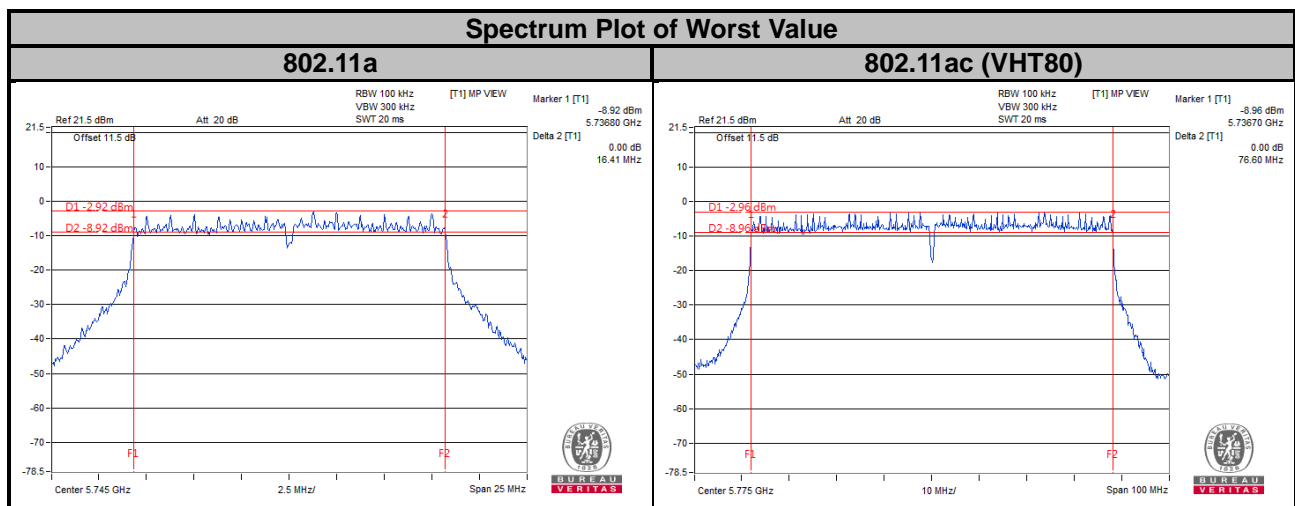

## 5 Pictures of Test Arrangements

Please refer to the attached file (Test Setup Photo).

### Annex A- Radiated Out of Band Emisison (OOBE) Measurement (For U-NII-3 band)

#### 802.11a

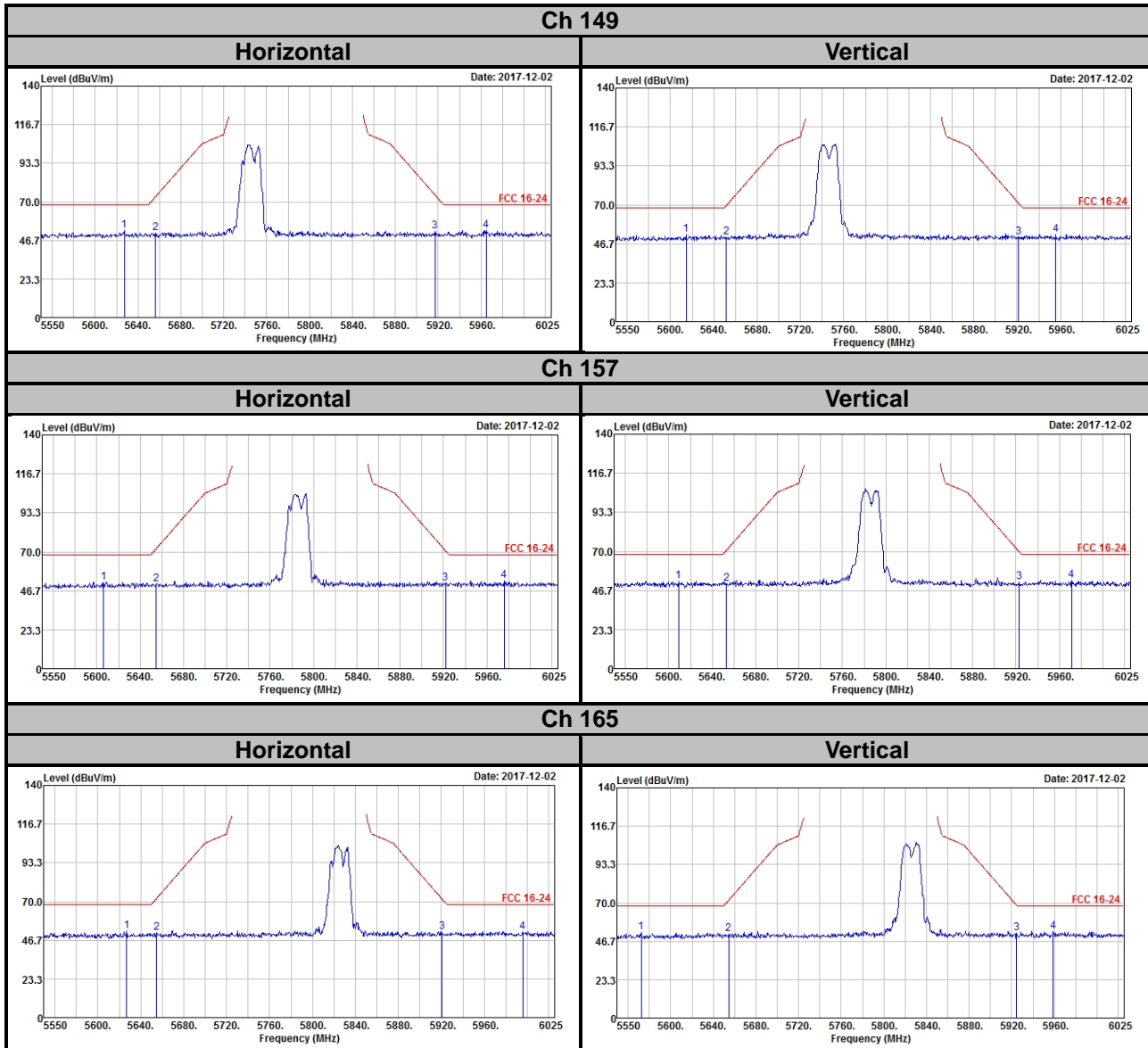

#### 802.11ac (VHT80)

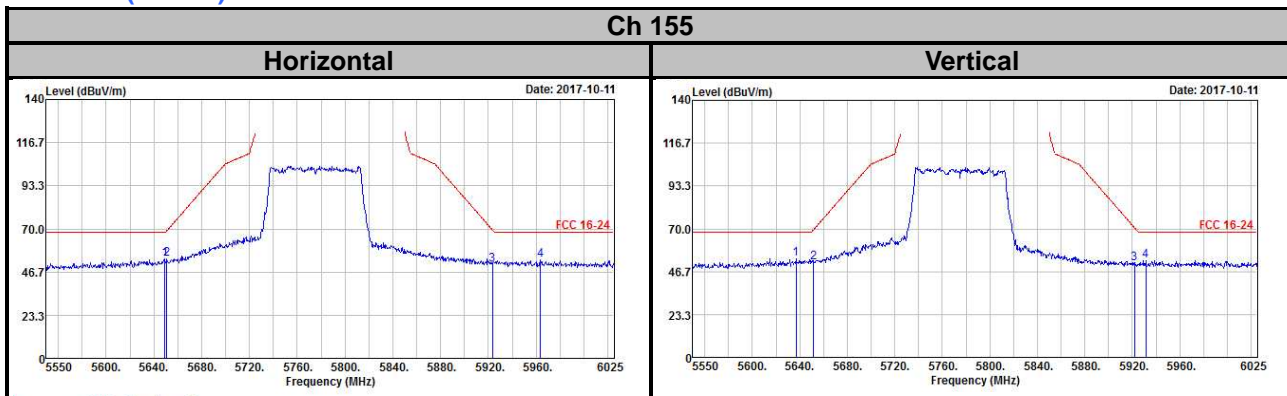



## Appendix – Information on the Testing Laboratories

We, Bureau Veritas Consumer Products Services (H.K.) Ltd., Taoyuan Branch, were founded in 1988 to provide our best service in EMC, Radio, Telecom and Safety consultation. Our laboratories are FCC recognized accredited test firms and accredited according to ISO/IEC 17025.

If you have any comments, please feel free to contact us at the following:

**Linko EMC/RF Lab**

Tel: 886-2-26052180

Fax: 886-2-26051924

**Hsin Chu EMC/RF/Telecom Lab**

Tel: 886-3-6668565

Fax: 886-3-6668323

**Hwa Ya EMC/RF/Safety**

Tel: 886-3-3183232

Fax: 886-3-3270892

**Email:** [service.adt@tw.bureauveritas.com](mailto:service.adt@tw.bureauveritas.com)

**Web Site:** [www.bureauveritas-adt.com](http://www.bureauveritas-adt.com)

The address and road map of all our labs can be found in our web site also.

--- END ---