



Test report No:  
2210382R-RF-US-P06V02

## FCC & ISED TEST REPORT

Product Name	LED device
Trademark	PHILIPS
Model and /or type reference	9290022691A,9290022692
FCC ID	2AGBW9290022691AX
IC	20812-2691AX
Applicant's name / address	Signify (China) Investment Co., Ltd Building no.9, Lane 888, Tianlin Road, Minhang District, Shanghai, 200233, China
Test method requested, standard	FCC CFR Title 47 Part 15 Subpart C Section 15.247 ANSI C63.10: 2013 KDB558074 D01 15.247 Meas Guidance v05r02 RSS-Gen Issue 5 RSS-247 Issue 2
Verdict Summary	IN COMPLIANCE
Tested by (name / position & signature)	Adma Lu/Project Engineer 
Approved by (name / position & signature)	Jack Zhang/Supervisor 
Date of issue	2022-03-24
Report Version	V1.1
Report template No	Template_FCC 15.247-RF-V1.0

## INDEX

	page
General conditions .....	4
Environmental conditions .....	4
Possible test case verdicts .....	5
Abbreviations.....	5
Document History.....	6
Remarks and Comments .....	6
Used Equipment.....	7
Uncertainty .....	9
1 General Information .....	10
1.1 General Description of the Item(s).....	10
1.2 Antenna Information .....	11
1.3 Channel List.....	12
2 Description of Test Setup.....	13
2.1 Operating mode(s) used for tests .....	13
2.2 Auxiliary equipment / Test software for the EUT .....	13
2.3 Test Configuration / Block diagram used for tests.....	14
2.4 Testing process .....	15
3 Verdict summary section.....	16
3.1 Standards .....	16
3.2 Deviation(s) from the Standard(s) / Test Specification(s).....	16
3.3 Overview of results .....	17
3.4 Test Facility.....	18
4 Test Results .....	19
4.1 AC Power Line Conducted Emission.....	19
4.1.1 Limit .....	19
4.1.2 Test Setup .....	19
4.1.3 Test Procedure .....	19
4.1.4 Test Data .....	20
4.2 Emissions in restricted frequency bands .....	22
4.2.1 Limit .....	22
4.2.2 Test Setup .....	24
4.2.3 Test Procedure .....	25
4.2.4 Test Data .....	26
4.3 Emissions in non-restricted frequency band .....	52

---

4.3.1	Limit .....	52
4.3.2	Test Setup .....	52
4.3.3	Test Procedure .....	52
4.3.4	Test Data .....	53
4.4	Duty cycle .....	56
4.4.1	Limit .....	56
4.4.2	Test Setup .....	56
4.4.3	Test Procedure .....	56
4.4.4	Test Data .....	57
4.5	Band Edge .....	58
4.5.1	Limit .....	58
4.5.2	Test Setup .....	58
4.5.3	Test Procedure .....	58
4.5.4	Test Data .....	59
4.6	DTS Bandwidth .....	91
4.6.1	Limit .....	91
4.6.2	Test Setup .....	91
4.6.3	Test Procedure .....	91
4.6.4	Test Data .....	92
4.7	Fundamental emission output power .....	93
4.7.1	Limit .....	93
4.7.2	Test Setup .....	93
4.7.3	Test Procedure .....	94
4.7.4	Test Data .....	95
4.8	Power Density .....	96
4.8.1	Limit: .....	96
4.8.2	Test Setup .....	96
4.8.3	Test Procedure .....	96
4.8.4	Test Data .....	97
4.9	Antenna Requirement .....	98
4.9.1	Limit: .....	98
4.9.2	Antenna Connector Construction: .....	98
5	Test setup photo and EUT Photo .....	99

## COMPETENCES AND GUARANTEES

DEKRA is a testing laboratory competent to carry out the tests described in this report.

In order to assure the traceability to other national and international laboratories, DEKRA has a calibration and maintenance program for its measurement equipment.

DEKRA guarantees the reliability of the data presented in this report, which is the result of the measurements and the tests performed to the item under test on the date and under the conditions stated in the report and it is based on the knowledge and technical facilities available at DEKRA at the time of performance of the test.

DEKRA is liable to the client for the maintenance of the confidentiality of all information related to the item under test and the results of the test.

The results presented in this Test Report apply only to the particular item under test established in this document.

**IMPORTANT:** No parts of this report may be reproduced or quoted out of context, in any form or by any means, except in full, without the previous written permission of DEKRA.

## GENERAL CONDITIONS

Test Location	No. 99, Hongye Road, Suzhou Industrial Park Suzhou, 215006, P.R. China
Date(receive sample)	Jan. 11, 2022
Date (start test)	Jun. 13, 2022
Date (finish test)	Feb.15, 2022

1. This report is only referred to the item that has undergone the test.
2. This report does not constitute or imply on its own an approval of the product by the Certification Bodies or Competent Authorities.
3. This document is only valid if complete; no partial reproduction can be made without previous written permission of DEKRA.
4. This test report cannot be used partially or in full for publicity and/or promotional purposes without previous written permission of DEKRA.

## ENVIRONMENTAL CONDITIONS

The climatic conditions during the tests are within the limits specified by the manufacturer for the operation of the EUT and the test equipment. The climatic conditions during the tests were within the following limits:

Ambient temperature	15 °C – 35 °C
Relative Humidity air	30% - 60%

If explicitly required in the basic standard or applied product / product family standard the climatic values are recorded and documented separately in this test report.

## POSSIBLE TEST CASE VERDICTS

Test case does not apply to test object	N/A
Test object does meet requirement	P (Pass) / PASS
Test object does not meet requirement	F (Fail) / FAIL
Not measured	N/M

## ABBREVIATIONS

For the purposes of the present document, the following abbreviations apply:

EUT	: Equipment Under Test
QP	: Quasi-Peak
CAV	: CISPR Average
AV	: Average
CDN	: Coupling Decoupling Network
SAC	: Semi-Anechoic Chamber
OATS	: Open Area Test Site
BW	: Bandwidth
AM	: Amplitude Modulation
PM	: Pulse Modulation
HCP	: Horizontal Coupling Plane
VCP	: Vertical Coupling Plane
$U_N$	: Nominal voltage
$T_x$	: Transmitter
$R_x$	: Receiver
N/A	: Not Applicable
N/M	: Not Measured

## DOCUMENT HISTORY

Report No.	Version	Description	Issued Date
2210382R-RF-US-P06V02	V1.0	Initial issue of report.	2022-03-04
2210382R-RF-US-P06V02	V1.1	Corrected IC ID.	2022-03-24

## REMARKS AND COMMENTS

1. The equipment under test (EUT) does meet the essential requirements of the stated standard(s)/test(s).
2. These test results on a sample of the device are for the purpose of demonstrating Compliance with Part 15 Subpart C Paragraph 15.247, RSS-Gen Issue 5, RSS-247 Issue 2.
3. The measurement result is considered in conformance with the requirement if it is within the prescribed limit, It is not necessary to account the uncertainty associated with the measurement result.
4. The test results presented in this report relate only to the object tested.
5. The test report shall not be reproduced without the written approval of DEKRA Testing and Certification (Suzhou) Co., Ltd.
6. This report will not be used for social proof function in China market.
7. DEKRA declines any responsibility with the following test data provided by customer that may affect the validity of result:
  - Chapter 1.1 General Description of the Item(s);
  - Chapter 1.2 Antenna Information;
  - Chapter 1.3 Channel List.

## USED EQUIPMENT

### AC Power Line Conducted Emission / TR1

Instrument	Manufacturer	Model No.	Serial No.	Cal. Date	Next Cal. Date
EMI Test Receiver	R&S	ESCI	100906	2021.04.28	2022.04.27
Two-Line V-Network	R&S	ENV216	101044	2021.03.20	2022.03.19
50ohm Termination	SHX	TF2	7081403	2021.09.04	2022.09.03
50ohm Coaxial Switch	Anritsu	MP59B	6200464462	N/A	N/A
Temperature/Humidity Meter	RTS	RTS-8S	TR1-TH	2021.07.09	2022.07.08
Dekra test software	Dekra	-	-	-	-

### Emissions in non-restricted frequency bands/ Occupied Bandwidth/ Fundamental emission output power/ Power Spectral Density/Band Edge/ TR8

Instrument	Manufacturer	Model No.	Serial No.	Cal. Date	Next Cal. Date
Spectrum Analyzer	Agilent	N9010A	MY48030494	2021.07.11	2022.07.10
EXA Spectrum Analyzer	Keysight	N9010A	MY55370495	2021.03.20	2022.03.19
MXA Signal Analyzer	Keysight	N9020A	MY56060147	2021.07.11	2022.07.10
4TX MIMO Power Sensor	Keysight	X8750A	MY59400102	2022.02.10	2023.02.09
Coaxial Cable	Woken	SFL402	F02-150410-044	2021.12.31	2022.12.30
Temperature/Humidity Meter	RTS	RTS-8S	RF08	2021.07.09	2022.07.08

### Radiated Emission(30MHz-1GHz) / AC3

Instrument	Manufacturer	Model No.	Serial No.	Cal. Date	Next Cal. Date
EMI Test Receiver	R&S	ESCI	100176	2021.08.15	2022.08.14
Loop Antenna	R&S	HFH2-Z2	833799/003	2021.03.04	2022.03.03
Bilog Antenna	Teseq GmbH	CBL6112D	27613	2021.08.23	2022.08.22
Coaxial Cable	Huber+Suhner	RG 214	AC3-C	2021.03.31	2022.03.30
Temperature/Humidity Meter	RTS	RTS-8S	AC3-TH	2021.07.09	2022.07.08
Dekra test software	Dekra	-	-	-	-

## Radiated Emission(1GHz-40GHz) / AC5

Instrument	Manufacturer	Model No.	Serial No.	Cal. Date	Next Cal. Date
EXA Spectrum Analyzer	Keysight	N9010A	MY55370495	2021.03.20	2022.03.19
Amplifier	Keleto	LNPA	SK20190225	2021.04.16	2022.04.15
Preamplifier	EMCI	EMC184045SE	980263	2021.05.22	2022.05.21
DRG Horn Antenna	ETS-Lindgren	3117	00167055	2021.08.23	2022.08.22
Broad-Band Horn Antenna	Schwarzbeck	BBHA9170	294	2021.04.14	2023.04.13
Coaxial Cable	Huber+Suhner	SUCOFLEX 106	AC5-C2	2021.03.31	2022.03.30
Coaxial Cable	ROSENBERGER	LA1-C011- 2000/3000	AC5-40G	2021.03.20	2022.03.19
High-Pass Filter	Wainwright	WHKX3.0/18G- 12SS	AC5&AC6	2021.06.08	2022.06.07
Temperature/Humidity Meter	RTS	RTS-8S	AC5-TH	2021.07.09	2022.07.08
Dekra test software	Dekra	-	-	-	-



## UNCERTAINTY

Uncertainties have been calculated according to the DEKRA internal document. The reported expanded uncertainties are based on a standard uncertainty multiplied by a coverage factor of  $k=2$ , providing a level of confidence of approximately 95%. The Uncertainties is comply with standard required as below.

Test item	Uncertainty
AC Power Line Conducted Emission	9kHz~150kHz: 2.80dB 150kHz~30MHz: 2.40dB
Peak Power Output	$\pm 1.27$ dB
Radiated Emission(30MHz~1GHz)	Horizontal: 30MHz~200MHz: 3.50 dB 300MHz~1GHz: 3.60 dB Vertical: 30MHz~200MHz: 3.60 dB 300MHz~1GHz: 3.50 dB
Radiated Emission(1GHz~26.5GHz)	Horizontal: 1GHz~18GHz: 5.00 dB Vertical: 1GHz~18GHz: 4.80 dB
RF antenna conducted test	$\pm 1.27$ dB
Radiated Emission Band Edge	$\pm 3.9$ dB
DTS Bandwidth	$\pm 150$ Hz
Occupied Bandwidth	$\pm 1$ kHz
Power Density	$\pm 1.27$ dB

# 1 GENERAL INFORMATION

## 1.1 General Description of the Item(s)

Product Name .....	LED device
Model No. ....	9290022691A,9290022692
FCC ID .....	2AGBW9290022691AX
IC .....	20812-2691AX
Manufacturer .....	Signify (China) Investment Co., Ltd
Manufacturer Address .....	Building no.9, Lane 888, Tianlin Road, Minhang District, Shanghai, 200233, China
Model differences .....	The length of model 9290022691A is the initial 2m and model 9290022692 is 1m that can be attached to 2m. The maximum length of this product is 10m.

Wireless specification.....	Bluetooth 5.0					
Operating frequency range(s) .....	2400~2483.5MHz					
Type of Modulation.....	GFSK					
PHYs .....	<input checked="" type="checkbox"/>	LE 1M	<input checked="" type="checkbox"/>	LE 2M	<input checked="" type="checkbox"/>	LE Coded S=2/8
Data Rate .....	<input checked="" type="checkbox"/>	1Mbit/s	<input checked="" type="checkbox"/>	2Mbit/s	<input checked="" type="checkbox"/>	500/125 Kbit/s
Number of channel .....	40					

Rated power supply .....	Voltage and Frequency					
	<input type="checkbox"/>	AC: 100-240 Vac, 50/60 Hz;				
	<input checked="" type="checkbox"/>	AC: 110 – 130 Vac, 50/60 Hz				
	<input type="checkbox"/>	48 Volt via POE				
	<input type="checkbox"/>	Adapter: Input: 100-240V,50/60H, 0.3A Output:5V,2A ,10W				
Mounting position .....	<input type="checkbox"/>	Table top equipment				
	<input checked="" type="checkbox"/>	Wall/Ceiling mounted equipment				
	<input type="checkbox"/>	Floor standing equipment				
	<input type="checkbox"/>	Head-mounted equipment				
	<input type="checkbox"/>	Other: Watch				

## 1.2 Antenna Information

Antenna model / type number .....	N/A		
Antenna serial number .....	N/A		
Antenna Delivery .....	<input checked="" type="checkbox"/>	1TX + 1RX	
	<input type="checkbox"/>	2TX + 2RX	
	<input type="checkbox"/>	Others:.....	
Antenna technology .....	<input checked="" type="checkbox"/>	SISO	
	<input type="checkbox"/>	MIMO	<input type="checkbox"/> CDD
			<input type="checkbox"/> Beam-forming
Antenna Type .....	<input type="checkbox"/>	External	<input type="checkbox"/> Dipole
			<input type="checkbox"/> Sectorized
	<input checked="" type="checkbox"/>	Internal	<input type="checkbox"/> PIFA
			<input checked="" type="checkbox"/> PCB
			<input type="checkbox"/> Dipole
			<input type="checkbox"/> Others.....
			Antenna Gain .....

### 1.3 Channel List

Bluetooth Working Frequency of Each Channel:							
Channel	Frequency	Channel	Frequency	Channel	Frequency	Channel	Frequency
00	2402 MHz	01	2404 MHz	02	2406 MHz	03	2408 MHz
04	2410 MHz	05	2412 MHz	06	2414 MHz	07	2416 MHz
08	2418 MHz	09	2420 MHz	10	2422 MHz	11	2424 MHz
12	2426 MHz	13	2428 MHz	14	2430 MHz	15	2432 MHz
16	2434 MHz	17	2436 MHz	18	2438 MHz	19	2440 MHz
20	2442 MHz	21	2444 MHz	22	2446 MHz	23	2448 MHz
24	2450 MHz	25	2452 MHz	26	2454 MHz	27	2456 MHz
28	2458 MHz	29	2460 MHz	30	2462 MHz	31	2464 MHz
32	2466 MHz	33	2468 MHz	34	2470 MHz	35	2472 MHz
36	2474 MHz	37	2476 MHz	38	2478 MHz	39	2480 MHz

Note: The general description of the Item(s), antenna information and channel list in clause 1 are provided and confirmed by the client.

## 2 DESCRIPTION OF TEST SETUP

### 2.1 Operating mode(s) used for tests

During the tests the following operating mode(s) has(have) been used.

Test Mode For Bluetooth	Mode1: Transmit by LE_1Mbps
	Mode2: Transmit by LE_2Mbps
	Mode3: Transmit by LE_Coded S=2
	Mode4: Transmit by LE_Coded S=8

### 2.2 Auxiliary equipment / Test software for the EUT

Auxiliary equipment	Type / Version	Manufacturer	Supplied by
Notebook	2526	Think Pad	N/A
Software	Type / Version	Manufacturer	Supplied by
HueApprobatonTool	N/A	N/A	N/A

### 2.3 Test Configuration / Block diagram used for tests

Test setup Diagram- AC Line Conducted Emission Test

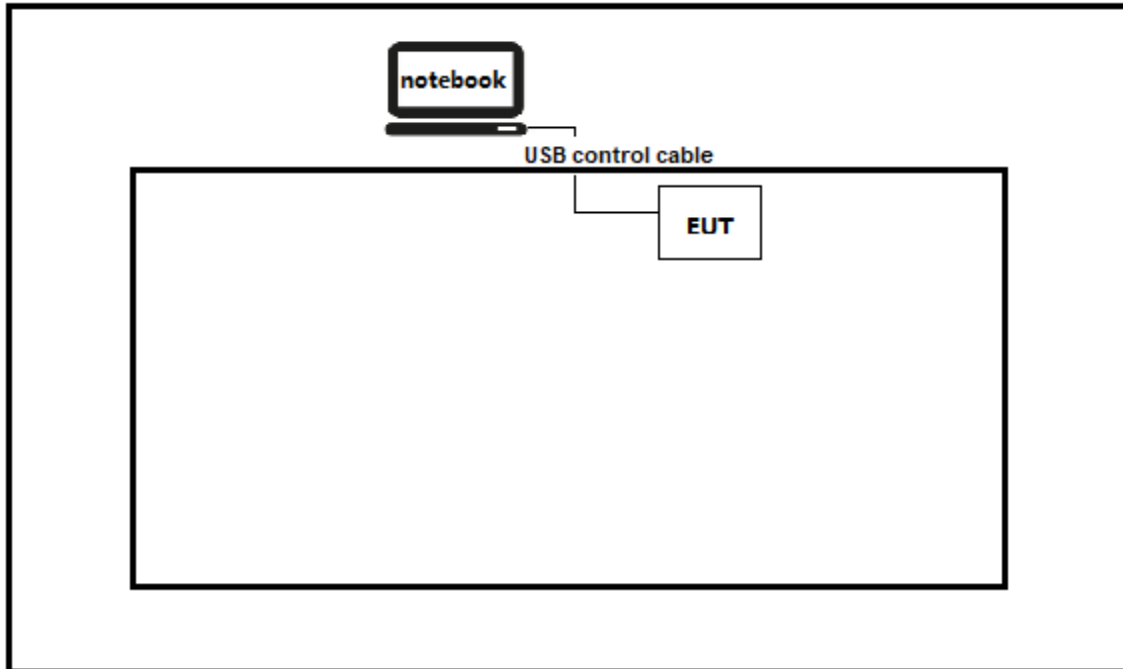

Test setup Diagram- Radiated Emission

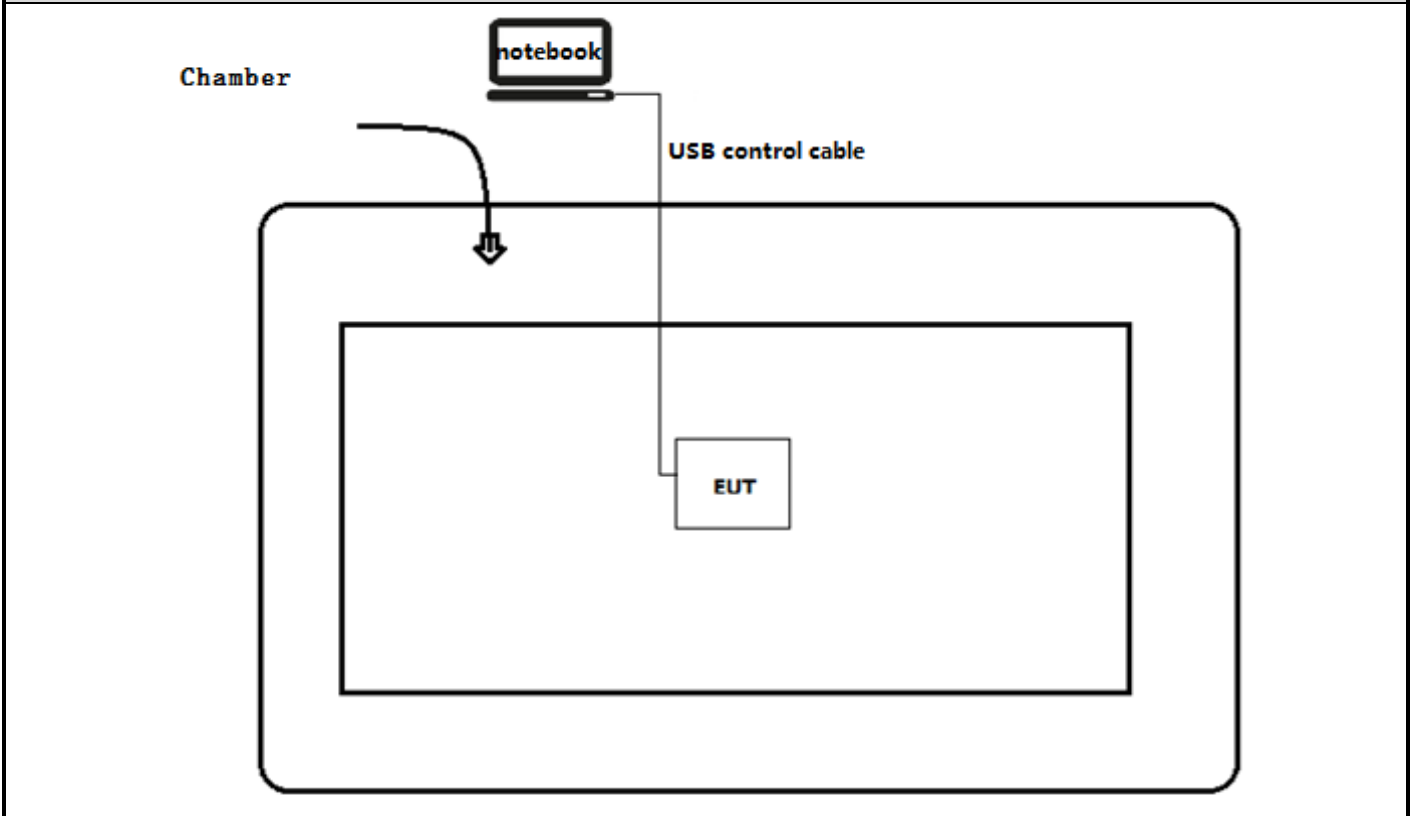

## 2.4 Testing process

1	Setup the EUT as shown in Section 2.3.
2	Run the software "HueApprobationTool" on the notebook computer.
3	Open the serial port and enter the corresponding commands to configure the test mode, test channel, test power and data rate.
4	Verify that the EUT works properly.

### 3 VERDICT SUMMARY SECTION

This chapter presents an overview of standards and results. Refer to the next chapters for details of measured test results and applied test levels.

#### 3.1 Standards

Standard	Year	Description
FCC CFR Title 47 Part 15 Subpart C Section 15.247	2021	Operation within the bands 902–928 MHz, 2400–2483.5 MHz, and 5725–5850 MHz.
ANSI C63.10	2013	American National Standard of Procedures for Compliance Testing of Unlicensed Wireless Devices
KDB558074 D01 v05r02	2019	Guidance for performing compliance measurements on Digital Transmission System (DTS) operating under section 15.247
RSS-Gen Issue 5 Amendment 2	2021	General Requirements for Compliance of Radio Apparatus
RSS-247 Issue 2	2017	Digital Transmission Systems (DTSs), Frequency Hopping Systems (FHSs) and Licence-Exempt Local Area Network (LE-LAN) Devices

#### 3.2 Deviation(s) from the Standard(s) / Test Specification(s)

The following deviation(s) was / were made from the published requirements of the listed standards: N/A.

*(Please define the deviations from the standard(s) if applicable)*



### 3.3 Overview of results

#### For FCC

Requirement – Test case	Basic standard(s)	Verdict	Remark
AC Power Line Conducted Emission	FCC 15.207	PASS	---
Emissions in restricted frequency bands	FCC 15.247(b)(3)	PASS	---
Duty cycle	ANSI C63.10:2013	PASS	---
Emissions in non-restricted frequency bands	FCC 15.247(d), FCC 15.209	PASS	---
Band Edge	FCC 15.247(d)	PASS	---
Fundamental emission output power	FCC 15.247(d), FCC 15.209	PASS	---
DTS Bandwidth	FCC 15.247(a)(2)	PASS	---
Power Spectral Density	FCC 15.247(e)	PASS	---
Antenna Requirement	FCC 15.203	PASS	---

#### For ISED

Requirement – Test case	Basic standard(s)	Verdict	Remark
AC Power Line Conducted Emission	RSS-Gen Issue 5 Section 8.8	PASS	---
Emissions in restricted frequency bands	RSS-Gen Issue 5 Section 8.9	PASS	---
Duty cycle	ANSI C63.10:2013	PASS	---
Emissions in non-restricted frequency bands	RSS-247 Issue 2 Section 5.5	PASS	---
Band Edge	RSS-Gen Issue 5 Section 8.10	PASS	---
Fundamental emission output power	RSS-247 Issue 2 Section 5.4(d)	PASS	---
DTS Bandwidth	RSS-Gen Issue 5 Section 6.7	PASS	---
Power Spectral Density	RSS-247 Issue 2 Section 5.2(b)	PASS	---
Antenna Requirement	RSS-Gen Issue 5 Section 6.8	PASS	---

---

### 3.4 Test Facility

**USA : FCC Designation Number: CN1199**

**CA : ISED CAB identifier: CN0040**

## 4 TEST RESULTS

### 4.1 AC Power Line Conducted Emission

VERDICT: PASS

#### 4.1.1 Limit

Standard		
FCC Part 15 Subpart C Paragraph 15.207		
Frequency range [MHz]	Limit: QP [dB(μV) <sup>1)</sup>	Limit: AV [dB(μV) <sup>1)</sup>
0,15 - 0,50	66 - 56 <sup>2)</sup>	56 - 46 <sup>2)</sup>
0,50 - 5,0	56	46
5,0 - 30	60	50

<sup>1)</sup> At the transition frequency, the lower limit applies.

<sup>2)</sup> The limit decreases linearly with the logarithm of the frequency.

**NOTE 1:** The exclusion band for transmitters shall be considered for transmitters operating at frequencies below 30 MHz.

**NOTE 2:** Where the AC output port is directly connected (or via a circuit breaker) to the AC power input port of the EUT the AC power output port need not to be tested.

#### 4.1.2 Test Setup

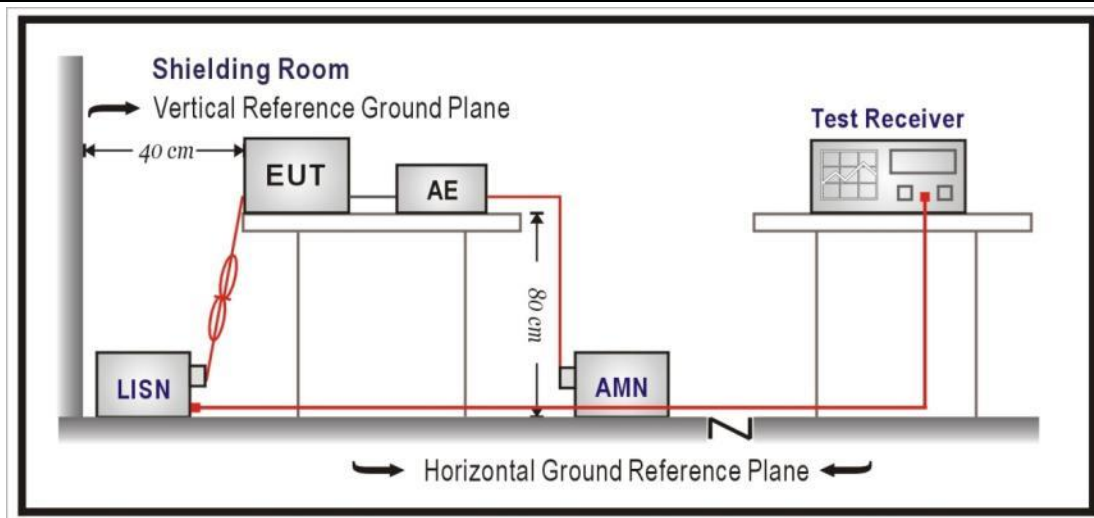

#### 4.1.3 Test Procedure

	References Rule	Chapter	Item
<input checked="" type="checkbox"/>	ANSI C63.10-2013	6.2	Standard test method for ac power-line conducted emissions from unlicensed wireless devices

**4.1.4 Test Data**

Profile: 2210382R	Page No.: 25
Engineer: Juliuszhou	
Site: TR1	Time: 2022/02/15 - 21:31
Limit: FCC_Part15.107_CE_AC Power_ClassB	Margin: 0
Probe: ENV216_101190(0.009-30MHz)	Polarity: Neutral
EUT: LED device	Power: AC 120V/60Hz
Note: Mode1	

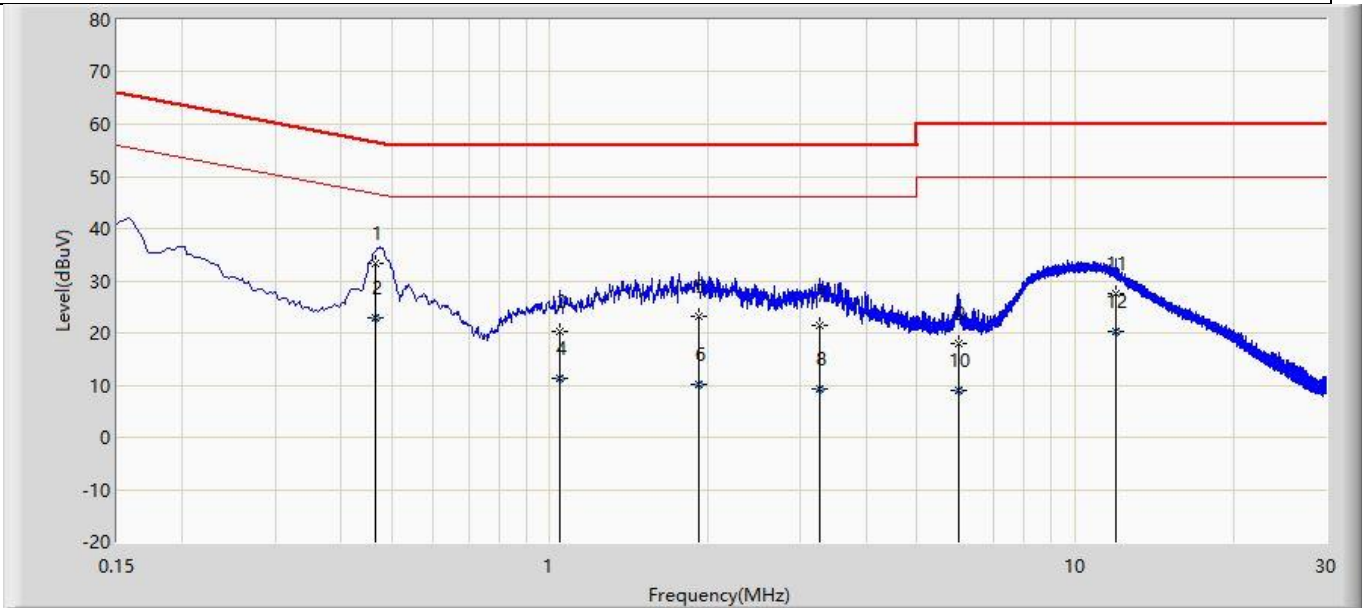

No	Mark	Frequency (MHz)	Measure Level (dBuV)	Reading Level (dBuV)	Over Limit (dB)	Limit (dBuV)	Factor (dB)	Type
1	*	0.467	33.469	23.853	-23.096	56.565	9.616	QP
2		0.467	22.780	13.164	-23.785	46.565	9.616	AV
3		1.046	20.242	10.592	-35.758	56.000	9.650	QP
4		1.046	11.180	1.530	-34.820	46.000	9.650	AV
5		1.919	23.302	13.630	-32.698	56.000	9.673	QP
6		1.919	10.220	0.548	-35.780	46.000	9.673	AV
7		3.262	21.398	11.665	-34.602	56.000	9.733	QP
8		3.262	9.331	-0.403	-36.669	46.000	9.733	AV
9		6.016	17.830	7.978	-42.170	60.000	9.852	QP
10		6.016	9.051	-0.801	-40.949	50.000	9.852	AV
11		11.983	27.540	17.474	-32.460	60.000	10.066	QP
12		11.983	20.350	10.284	-29.650	50.000	10.066	AV

Profile: 2210382R	Page No.: 30
Engineer: Juliuszhou	
Site: TR1	Time: 2022/02/15 - 21:42
Limit: FCC_Part15.107_CE_AC Power_ClassB	Margin: 0
Probe: ENV216_101190(0.009-30MHz)	Polarity: Line
EUT: LED device	Power: AC 120V/60Hz
Note: Mode1	

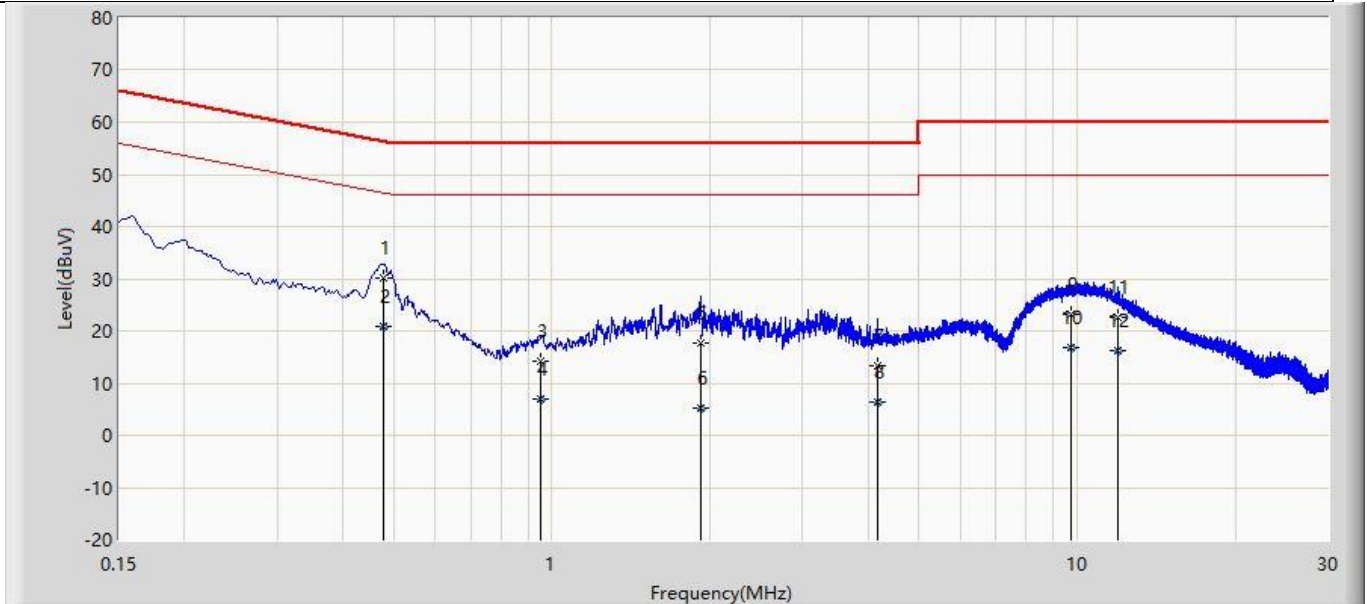

No	Mark	Frequency (MHz)	Measure Level (dBuV)	Reading Level (dBuV)	Over Limit (dB)	Limit (dBuV)	Factor (dB)	Type
1		0.478	30.183	20.566	-26.182	56.365	9.617	QP
2	*	0.478	21.006	11.389	-25.359	46.365	9.617	AV
3		0.951	14.325	4.676	-41.675	56.000	9.648	QP
4		0.951	7.099	-2.549	-38.901	46.000	9.648	AV
5		1.919	17.625	7.952	-38.375	56.000	9.673	QP
6		1.919	5.350	-4.323	-40.650	46.000	9.673	AV
7		4.171	13.472	3.693	-42.528	56.000	9.779	QP
8		4.171	6.341	-3.437	-39.659	46.000	9.779	AV
9		9.714	23.214	13.213	-36.786	60.000	10.002	QP
10		9.714	16.734	6.732	-33.266	50.000	10.002	AV
11		11.980	22.679	12.621	-37.321	60.000	10.058	QP
12		11.980	16.317	6.259	-33.683	50.000	10.058	AV

<b>4.2 Emissions in restricted frequency bands</b>	<b>VERDICT: PASS</b>
--	----------------------

4.2.1 Limit			
Standard		FCC Part 15 Subpart C Paragraph 15.209	
Restricted Bands of operationfor FCC			
Frequency (MHz)	Frequency (MHz)	Frequency (MHz)	Frequency (GHz)
0.090 – 0.110	16.42 – 16.423	399.9 – 410	4.5 – 5.15
0.495 – 0.505	16.69475 – 16.69525	608 – 614	5.35 – 5.46
2.1735 – 2.1905	16.80425 – 16.80475	960 – 1240	7.25 – 7.75
4.125 – 4.128	25.5 – 25.67	1300 – 1427	8.025 – 8.5
4.17725 – 4.17775	37.5 – 38.25	1435 – 1626.5	9.0 – 9.2
4.20725 – 4.20775	73 – 74.6	1645.5 – 1646.5	9.3 – 9.5
6.215 – 6.218	74.8 – 75.2	1660 – 1710	10.6 – 12.7
6.26775 – 6.26825	108 – 121.94	1718.8 – 1722.2	13.25 – 13.4
6.31175 – 6.31225	123 – 138	2200 – 2300	14.47 – 14.5
8.291 – 8.294	149.9 – 150.05	2310 – 2390	15.35 – 16.2
8.362 – 8.366	156.52475 – 156.52525	2483.5 – 2500	17.7 – 21.4
8.37625 – 8.38675	156.7 – 156.9	2690 – 2900	22.01 – 23.12
8.81425 – 8.81475	162.0125 – 167.17	3260 – 3267	23.6 – 24.0
12.29 – 12.293	167.72 – 173.2	3332 – 3339	31.2 – 31.8
12.51975 – 12.52025	240 – 285	3345.8 – 3358	36.43 – 36.5
12.57675 – 12.57725	322 – 335.4	3600 – 4400	
13.36 – 13.41			
Restricted Bands of operationfor IC			
0.090 - 0.110	13.36 - 13.41	960 - 1427	9.0 - 9.2
0.495 - 0.505	16.42 - 16.423	1435 - 1626.5	9.3 - 9.5
2.1735 - 2.1905	16.69475 - 16.69525	1645.5 - 1646.5	10.6 - 12.7
3.020 - 3.026	16.80425 - 16.80475	1660 - 1710	13.25 - 13.4
4.125 - 4.128	25.5 - 25.67	1718.8 - 1722.2	14.47 - 14.5
4.17725 - 4.17775	37.5 - 38.25	2200 - 2300	15.35 - 16.2
4.20725 - 4.20775	73 - 74.6	2310 - 2390	17.7 - 21.4
5.677 - 5.683	74.8 - 75.2	2483.5 - 2500	22.01 - 23.12
6.215 - 6.218	108 - 138	2655 - 2900	23.6 - 24.0
6.26775 - 6.26825	149.9 - 150.05	3260 - 3267	31.2 - 31.8
6.31175 - 6.31225	156.52475 - 156.52525	3332 - 3339	36.43 - 36.5
8.291 - 8.294	156.7 - 156.9	3345.8 - 3358	Above 38.6
8.362 - 8.366	162.0125 - 167.17	3500 - 4400	
8.37625 - 8.38675	167.72 - 173.2	4500 - 5150	
8.81425 - 8.81475	240 - 285	5350 - 5460	
12.29 - 12.293	322 - 335.4	7250 - 7750	
12.51975 - 12.52025	399.9 - 410	8025 - 8500	
12.57675 - 12.57725	608 - 614	--	

Restricted Band Emissions Limit			
Frequency (MHz)	Field strength ( $\mu\text{V/m}$ )	Field strength ( $\text{dB}\mu\text{V/m}$ )	Measurement distance (m)
0.009 - 0.49	2400/F(kHz)	48.5 – 13.8	300 <sub>(Note 1)</sub>
0.49 - 1.705	24000/F(kHz)	33.8 - 23	30 <sub>(Note 1)</sub>
1.705 - 30	30	29.5	30 <sub>(Note 1)</sub>
30 -88	100	40	3 <sub>(Note 2)</sub>
88-216	150	43.5	3 <sub>(Note 2)</sub>
216 - 960	200	46	3 <sub>(Note 2)</sub>
Above 960	500	54	3 <sub>(Note 2)</sub>

Note 1: At frequencies below 30 MHz, measurements may be performed at a distance closer than that specified in the regulations; however, an attempt should be made to avoid making measurements in the near field. Pending the development of an appropriate measurement procedure for measurements performed below 30 MHz, when performing measurements at a closer distance than specified, the results shall be extrapolated to the specified distance by either making measurements at a minimum of two distances on at least one radial to determine the proper extrapolation factor or by using the square of an inverse linear distance extrapolation factor (40 dB/decade).

Note 2: At frequencies at or above 30 MHz, measurements may be performed at a distance other than what is specified provided: measurements are not made in the near field except where it can be shown that near field measurements are appropriate due to the characteristics of the device; and it can be demonstrated that the signal levels needed to be measured at the distance employed can be detected by the measurement equipment. Measurements shall not be performed at a distance greater than 30 meters unless it can be further demonstrated that measurements at a distance of 30 meters or less are impractical. When performing measurements at a distance other than that specified, the results shall be extrapolated to the specified distance using an extrapolation factor of 20 dB/decade (inverse linear-distance for field strength measurements; inverse-linear-distance-squared for power density measurements).

### 4.2.2 Test Setup

Below 30MHz Test Setup:

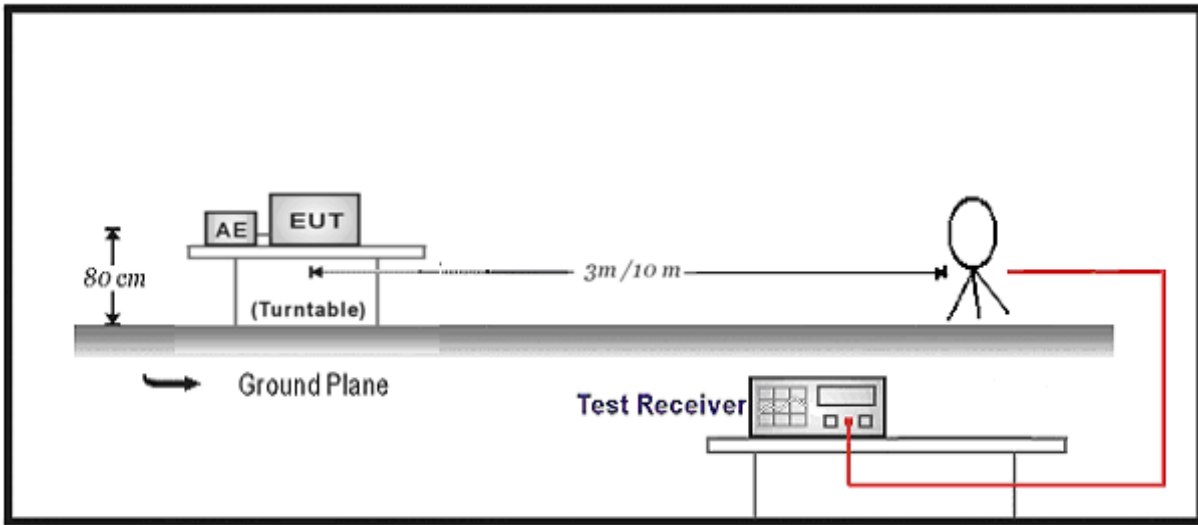

30MHz-1GHz Test Setup:

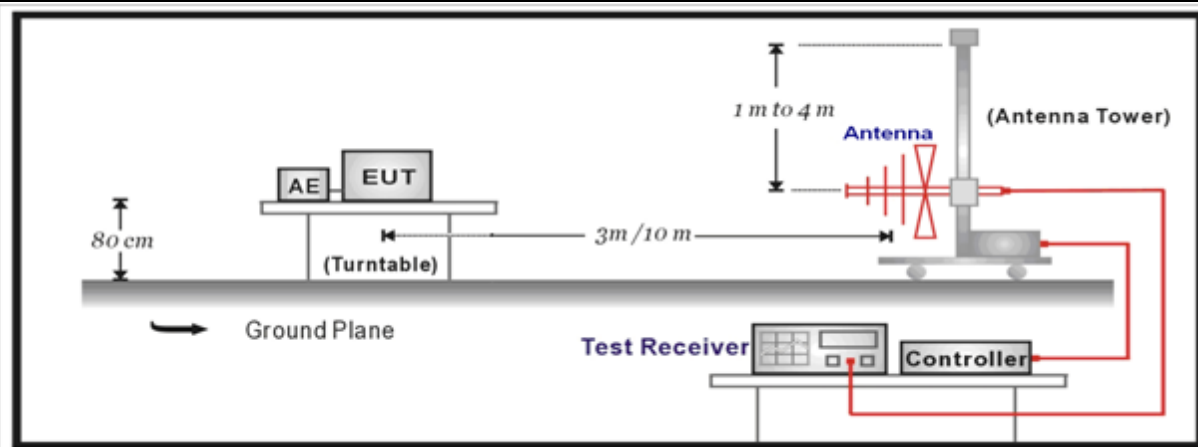

Above 1GHz Test Setup:

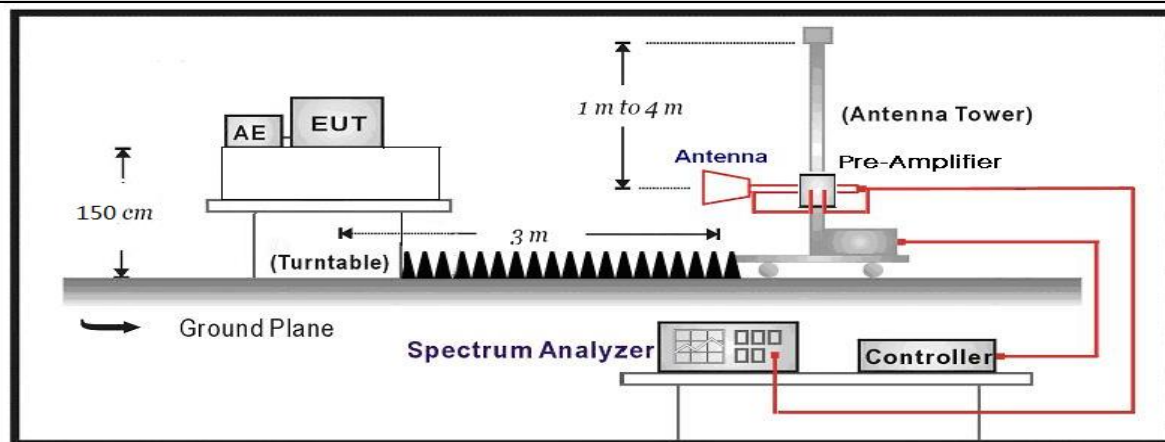



4.2.3 Test Procedure			
	References Rule	Chapter	Description
<input checked="" type="checkbox"/>	ANSI C63.10	11.12	Emissions in restricted frequency bands
<input checked="" type="checkbox"/>	<input checked="" type="checkbox"/> ANSI C63.10	11.12.1	Radiated emission measurements
<input checked="" type="checkbox"/>	<input checked="" type="checkbox"/> ANSI C63.10	11.12.2.7	Radiated spurious emission test
<input checked="" type="checkbox"/>	<input checked="" type="checkbox"/> ANSI C63.10	6.4	Radiated emissions from unlicensed wireless devices below 30 MHz
<input checked="" type="checkbox"/>	<input checked="" type="checkbox"/> ANSI C63.10	6.5	Radiated emissions from unlicensed wireless devices in the frequency range of 30 MHz to 1000 MHz
<input checked="" type="checkbox"/>	<input checked="" type="checkbox"/> ANSI C63.10	6.6	Radiated emissions from unlicensed wireless devices above 1 GHz

**4.2.4 Test Data**

Profile: 2210382R	Page No.: 31
Engineer: Tongben	
Site: AC5	Time: 2022/02/08 - 22:55
Limit: FCC_Part15.209_RE(3m)	Margin: 0
Probe: Horn_3117_00167055(1-18GHz)	Polarity: Horizontal
EUT: LED device	Power: AC 120V/60Hz
Note: Mode 1:Transmit at 2402MHz by BLE	

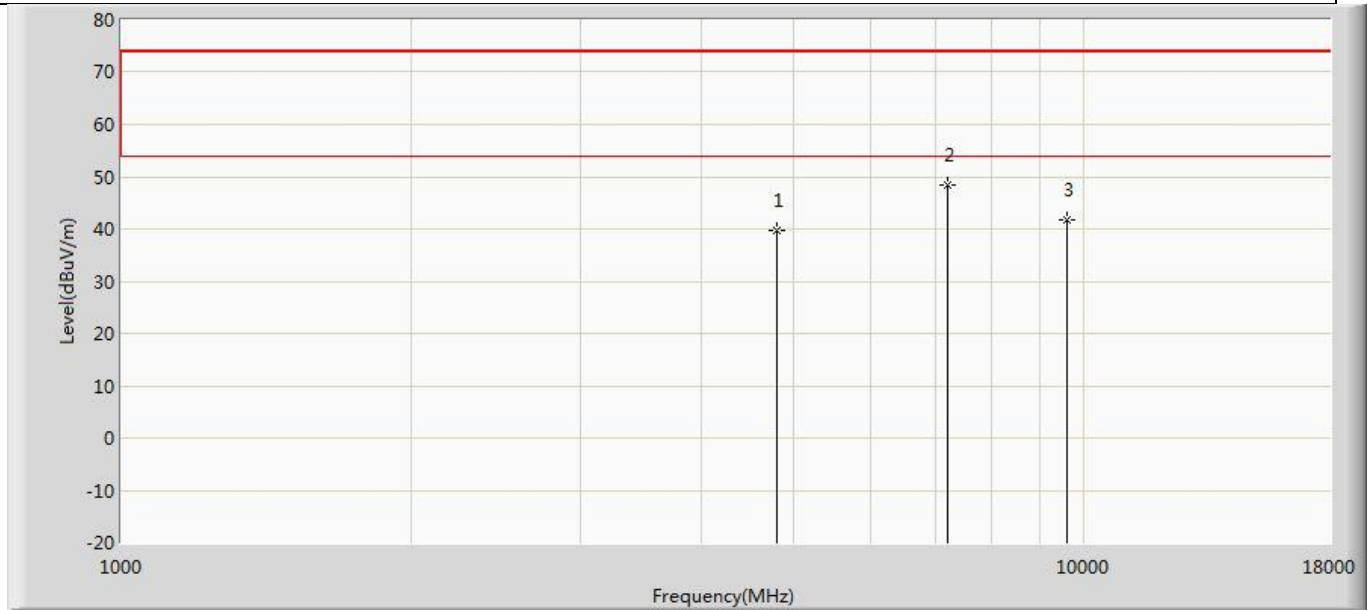

No	Mark	Frequency (MHz)	Measure Level (dBuV/m)	Reading Level (dBuV)	Over Limit (dB)	Limit (dBuV/m)	Factor (dB)	Type
1		4804.000	39.810	35.554	-34.190	74.000	4.256	PK
2	*	7205.000	48.497	40.790	-25.503	74.000	7.707	PK
3		9608.000	41.793	32.744	-32.207	74.000	9.050	PK

Profile: 2210382R	Page No.: 32
Engineer: Tongben	
Site: AC5	Time: 2022/02/08 - 22:55
Limit: FCC_Part15.209_RE(3m)	Margin: 0
Probe: Horn_3117_00167055(1-18GHz)	Polarity: Vertical
EUT: LED device	Power: AC 120V/60Hz
Note: Mode 1:Transmit at 2402MHz by BLE	

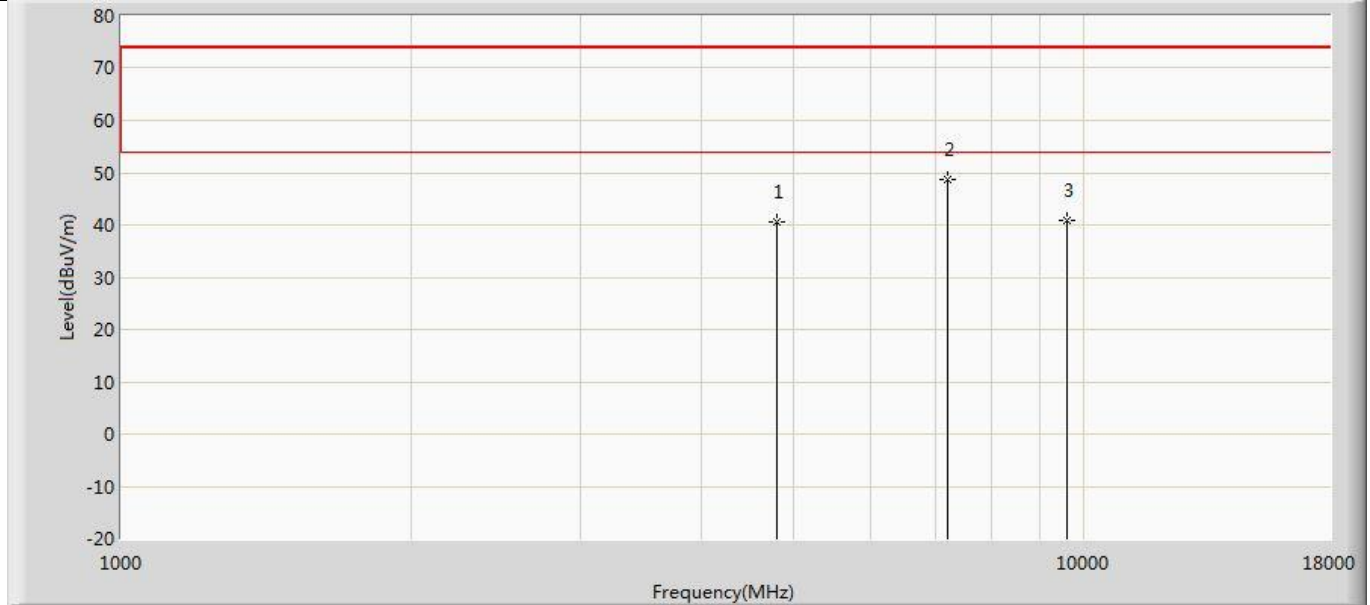

No	Mark	Frequency (MHz)	Measure Level (dBuV/m)	Reading Level (dBuV)	Over Limit (dB)	Limit (dBuV/m)	Factor (dB)	Type
1		4804.000	40.654	36.398	-33.346	74.000	4.256	PK
2	*	7205.000	48.728	41.021	-25.272	74.000	7.707	PK
3		9608.000	40.829	31.780	-33.171	74.000	9.050	PK

Profile: 2210382R	Page No.: 39
Engineer: Tongben	
Site: AC5	Time: 2022/02/08 - 22:56
Limit: FCC_Part15.209_RE(3m)	Margin: 0
Probe: Horn_3117_00167055(1-18GHz)	Polarity: Horizontal
EUT: LED device	Power: AC 120V/60Hz
Note: Mode 1:Transmit at 2440MHz by BLE	

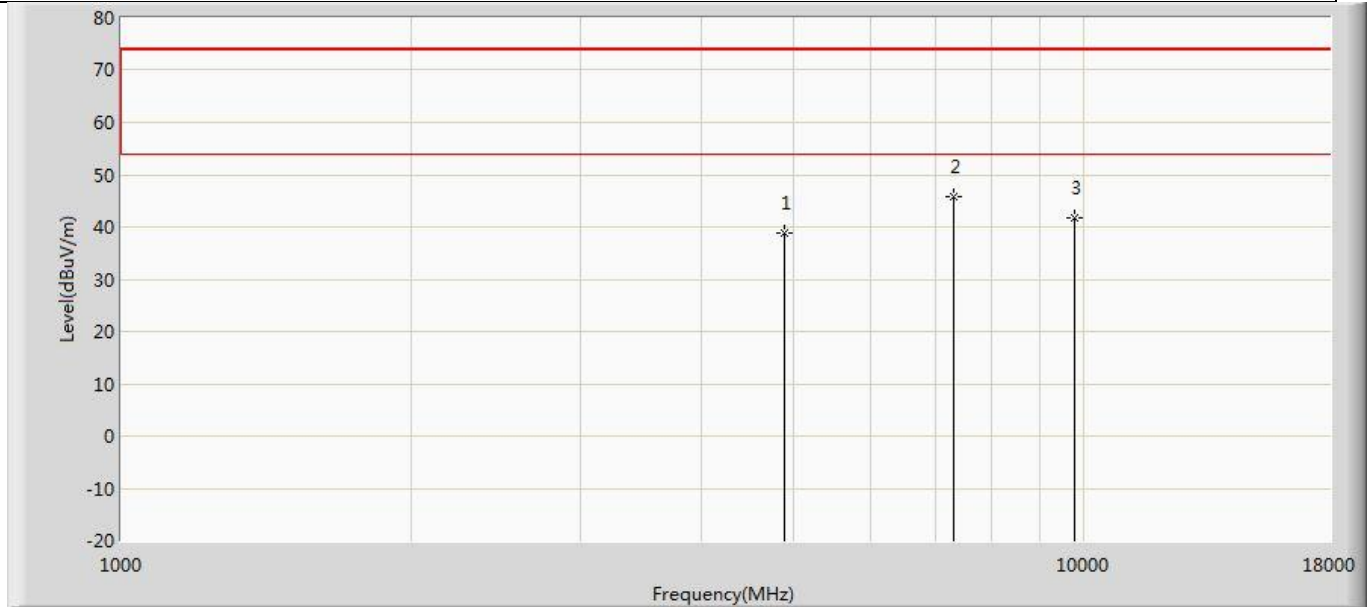

No	Mark	Frequency (MHz)	Measure Level (dBuV/m)	Reading Level (dBuV)	Over Limit (dB)	Limit (dBuV/m)	Factor (dB)	Type
1		4880.000	38.827	34.402	-35.173	74.000	4.425	PK
2	*	7315.500	45.703	37.853	-28.297	74.000	7.850	PK
3		9760.000	41.622	32.331	-32.378	74.000	9.291	PK

Profile: 2210382R	Page No.: 40
Engineer: Tongben	
Site: AC5	Time: 2022/02/08 - 22:56
Limit: FCC_Part15.209_RE(3m)	Margin: 0
Probe: Horn_3117_00167055(1-18GHz)	Polarity: Vertical
EUT: LED device	Power: AC 120V/60Hz
Note: Mode 1:Transmit at 2440MHz by BLE	

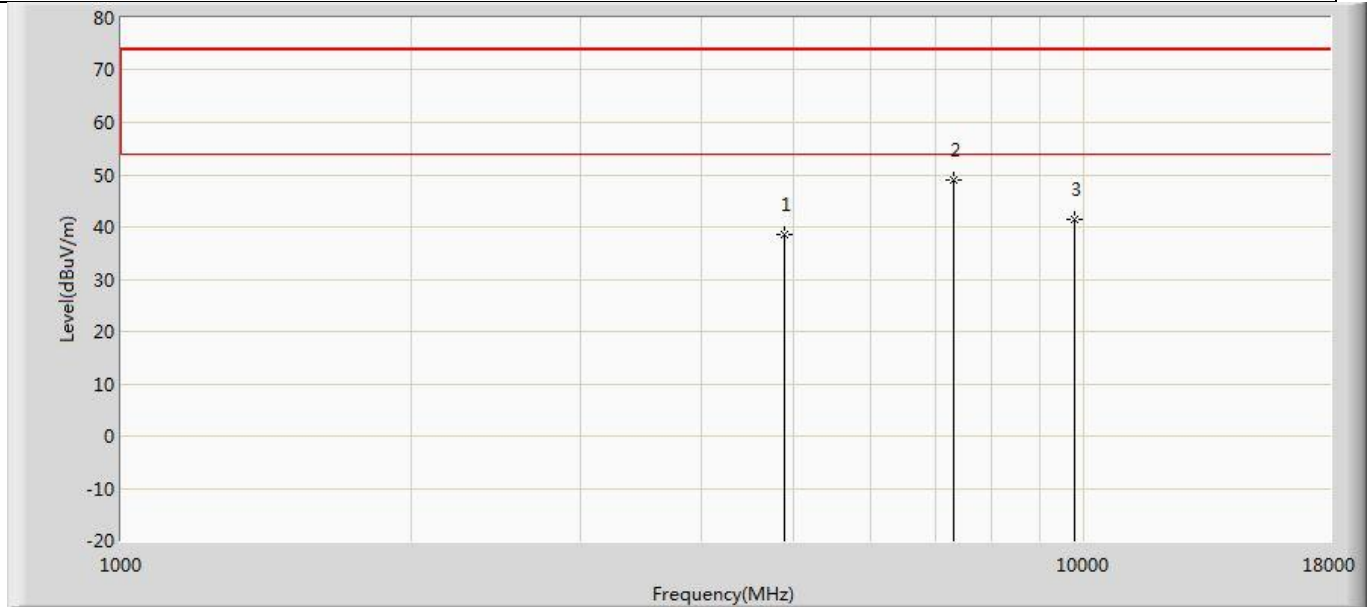

No	Mark	Frequency (MHz)	Measure Level (dBuV/m)	Reading Level (dBuV)	Over Limit (dB)	Limit (dBuV/m)	Factor (dB)	Type
1		4880.000	38.554	34.129	-35.446	74.000	4.425	PK
2	*	7315.500	48.873	41.023	-25.127	74.000	7.850	PK
3		9760.000	41.449	32.158	-32.551	74.000	9.291	PK

Profile: 2210382R	Page No.: 47
Engineer: Tongben	
Site: AC5	Time: 2022/02/08 - 22:57
Limit: FCC_Part15.209_RE(3m)	Margin: 0
Probe: Horn_3117_00167055(1-18GHz)	Polarity: Horizontal
EUT: LED device	Power: AC 120V/60Hz
Note: Mode 1:Transmit at 2480MHz by BLE	

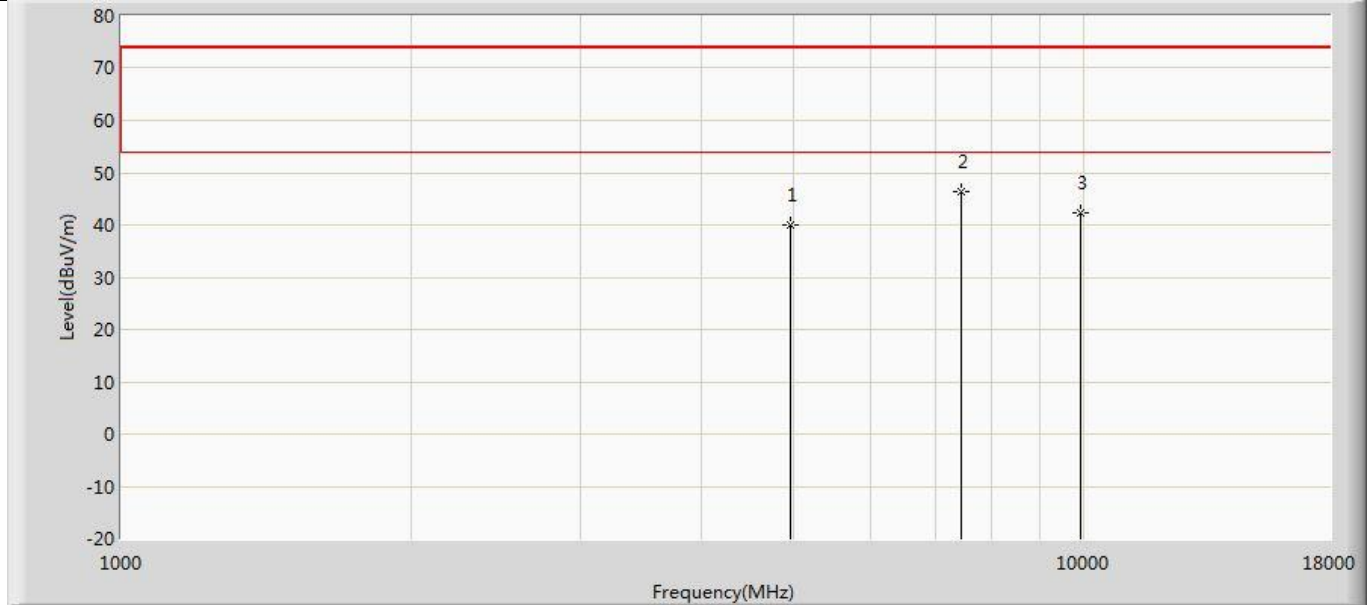

No	Mark	Frequency (MHz)	Measure Level (dBuV/m)	Reading Level (dBuV)	Over Limit (dB)	Limit (dBuV/m)	Factor (dB)	Type
1		4960.000	40.126	35.729	-33.874	74.000	4.397	PK
2	*	7443.000	46.507	38.586	-27.493	74.000	7.920	PK
3		9920.000	42.174	32.819	-31.826	74.000	9.354	PK

Profile: 2210382R	Page No.: 48
Engineer: Tongben	
Site: AC5	Time: 2022/02/08 - 22:57
Limit: FCC_Part15.209_RE(3m)	Margin: 0
Probe: Horn_3117_00167055(1-18GHz)	Polarity: Vertical
EUT: LED device	Power: AC 120V/60Hz
Note: Mode 1:Transmit at 2480MHz by BLE	

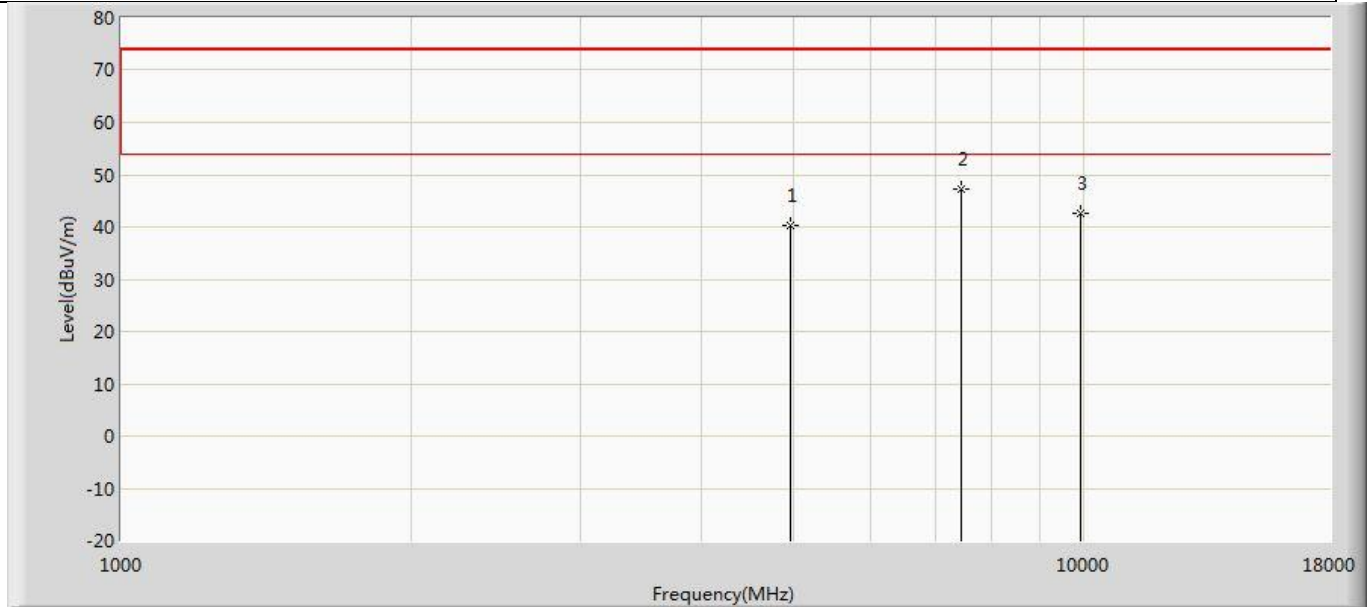

No	Mark	Frequency (MHz)	Measure Level (dBuV/m)	Reading Level (dBuV)	Over Limit (dB)	Limit (dBuV/m)	Factor (dB)	Type
1		4960.000	40.424	36.027	-33.576	74.000	4.397	PK
2	*	7443.000	47.233	39.312	-26.767	74.000	7.920	PK
3		9920.000	42.513	33.158	-31.487	74.000	9.354	PK

Profile: 2210382R	Page No.: 33
Engineer: Tongben	
Site: AC5	Time: 2022/02/08 - 22:55
Limit: FCC_Part15.209_RE(3m)	Margin: 0
Probe: Horn_3117_00167055(1-18GHz)	Polarity: Horizontal
EUT: LED device	Power: AC 120V/60Hz
Note: Mode 2:Transmit at 2402MHz by 2LE	

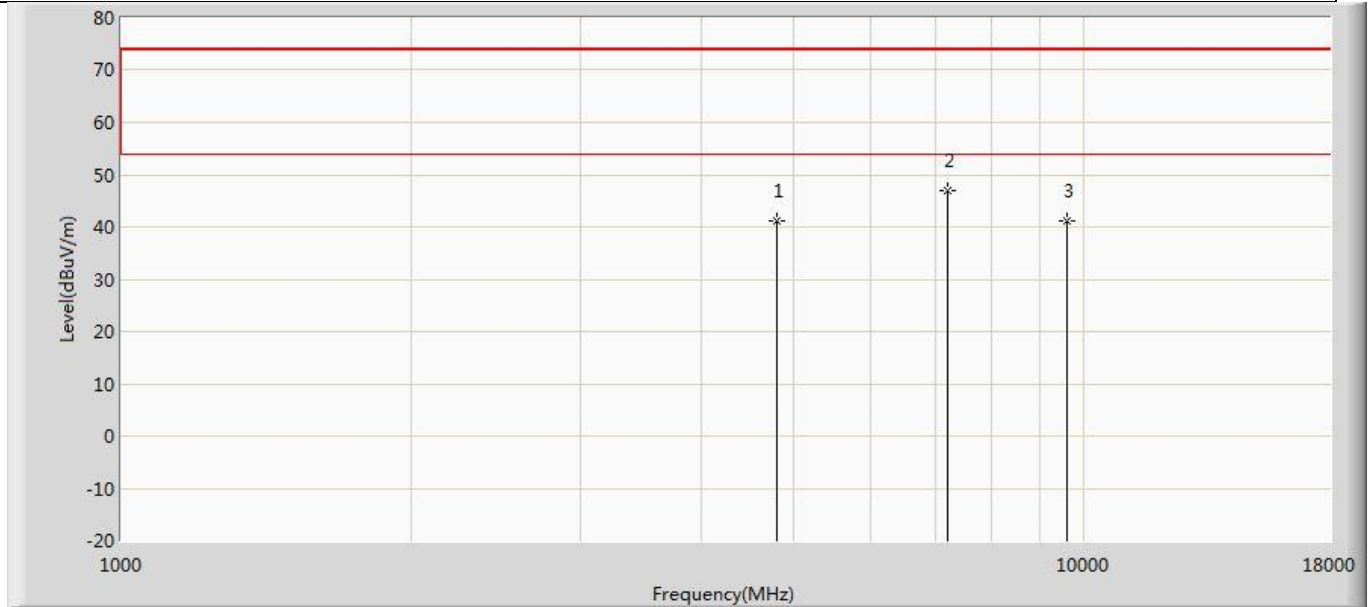

No	Mark	Frequency (MHz)	Measure Level (dBuV/m)	Reading Level (dBuV)	Over Limit (dB)	Limit (dBuV/m)	Factor (dB)	Type
1		4804.000	41.016	36.760	-32.984	74.000	4.256	PK
2	*	7205.000	46.956	39.249	-27.044	74.000	7.707	PK
3		9608.000	41.262	32.213	-32.738	74.000	9.050	PK



Profile: 2210382R	Page No.: 34
Engineer: Tongben	
Site: AC5	Time: 2022/02/08 - 22:56
Limit: FCC_Part15.209_RE(3m)	Margin: 0
Probe: Horn_3117_00167055(1-18GHz)	Polarity: Vertical
EUT: LED device	Power: AC 120V/60Hz
Note: Mode 2:Transmit at 2402MHz by 2LE	

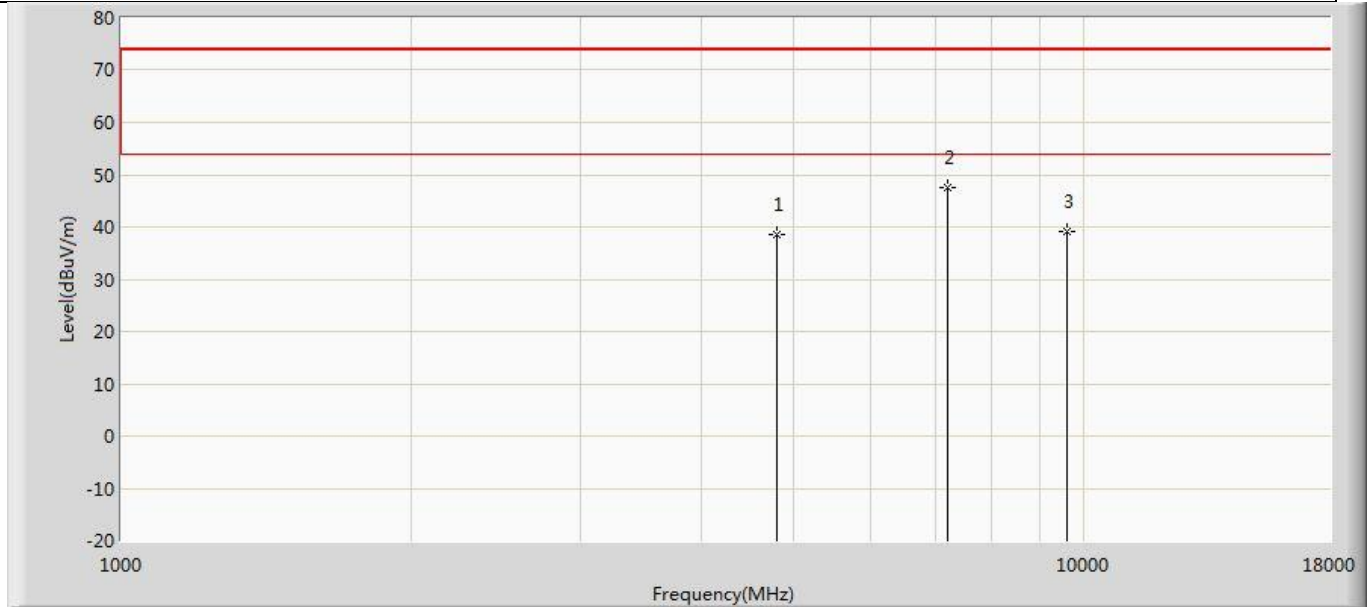

No	Mark	Frequency (MHz)	Measure Level (dBuV/m)	Reading Level (dBuV)	Over Limit (dB)	Limit (dBuV/m)	Factor (dB)	Type
1		4804.000	38.540	34.284	-35.460	74.000	4.256	PK
2	*	7205.000	47.671	39.964	-26.329	74.000	7.707	PK
3		9608.000	39.203	30.154	-34.797	74.000	9.050	PK

Profile: 2210382R	Page No.: 41
Engineer: Tongben	
Site: AC5	Time: 2022/02/08 - 22:56
Limit: FCC_Part15.209_RE(3m)	Margin: 0
Probe: Horn_3117_00167055(1-18GHz)	Polarity: Horizontal
EUT: LED device	Power: AC 120V/60Hz
Note: Mode 2:Transmit at 2440MHz by 2LE	

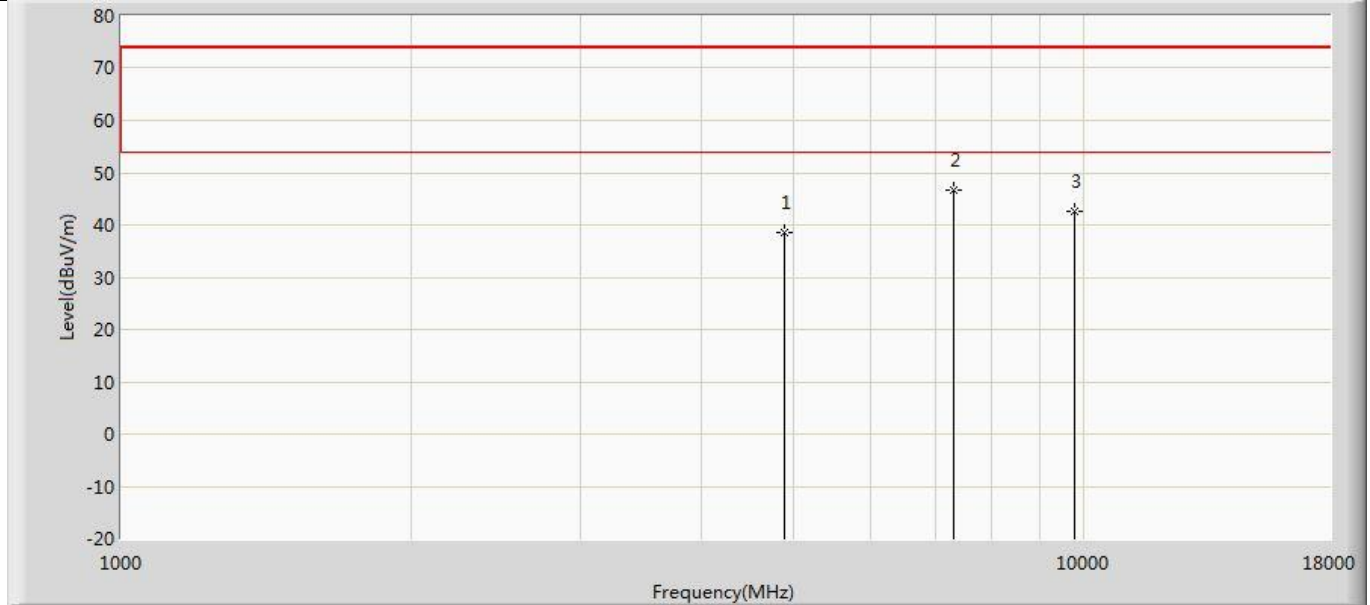

No	Mark	Frequency (MHz)	Measure Level (dBuV/m)	Reading Level (dBuV)	Over Limit (dB)	Limit (dBuV/m)	Factor (dB)	Type
1		4880.000	38.491	34.066	-35.509	74.000	4.425	PK
2	*	7324.000	46.781	38.995	-27.219	74.000	7.786	PK
3		9760.000	42.476	33.185	-31.524	74.000	9.291	PK

Profile: 2210382R	Page No.: 42
Engineer: Tongben	
Site: AC5	Time: 2022/02/08 - 22:56
Limit: FCC_Part15.209_RE(3m)	Margin: 0
Probe: Horn_3117_00167055(1-18GHz)	Polarity: Vertical
EUT: LED device	Power: AC 120V/60Hz
Note: Mode 2:Transmit at 2440MHz by 2LE	

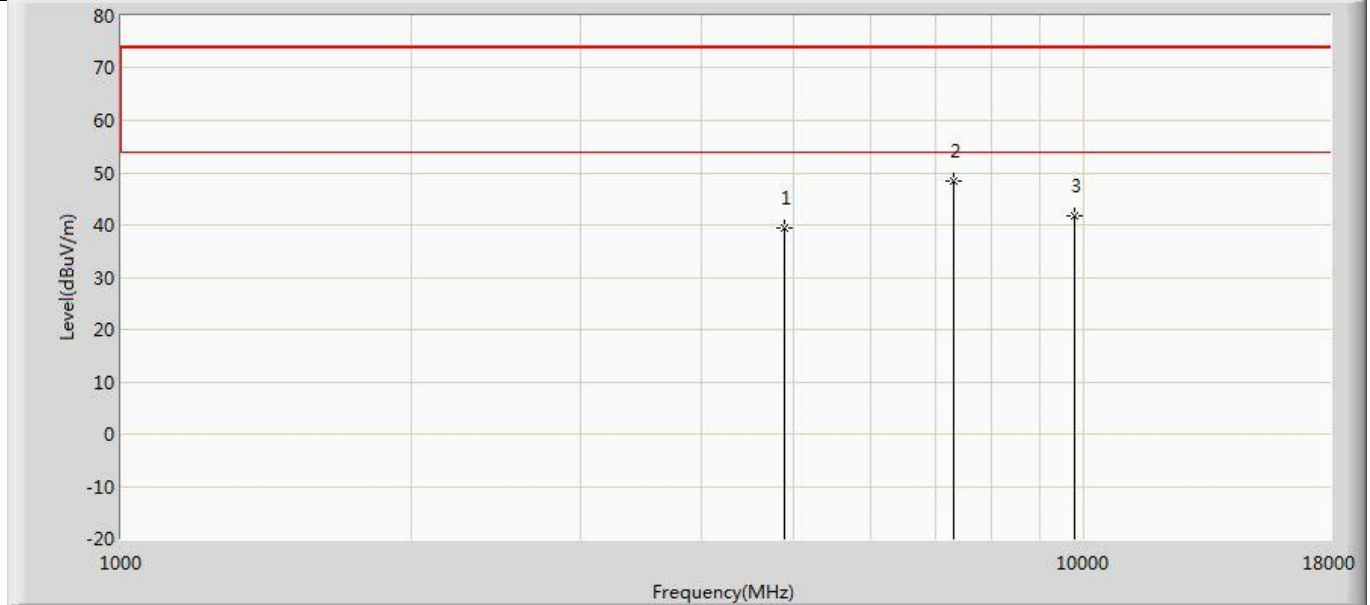

No	Mark	Frequency (MHz)	Measure Level (dBuV/m)	Reading Level (dBuV)	Over Limit (dB)	Limit (dBuV/m)	Factor (dB)	Type
1		4880.000	39.291	34.866	-34.709	74.000	4.425	PK
2	*	7315.500	48.296	40.446	-25.704	74.000	7.850	PK
3		9760.000	41.615	32.324	-32.385	74.000	9.291	PK

Profile: 2210382R	Page No.: 49
Engineer: Tongben	
Site: AC5	Time: 2022/02/08 - 22:57
Limit: FCC_Part15.209_RE(3m)	Margin: 0
Probe: Horn_3117_00167055(1-18GHz)	Polarity: Horizontal
EUT: LED device	Power: AC 120V/60Hz
Note: Mode 2:Transmit at 2480MHz by 2LE	

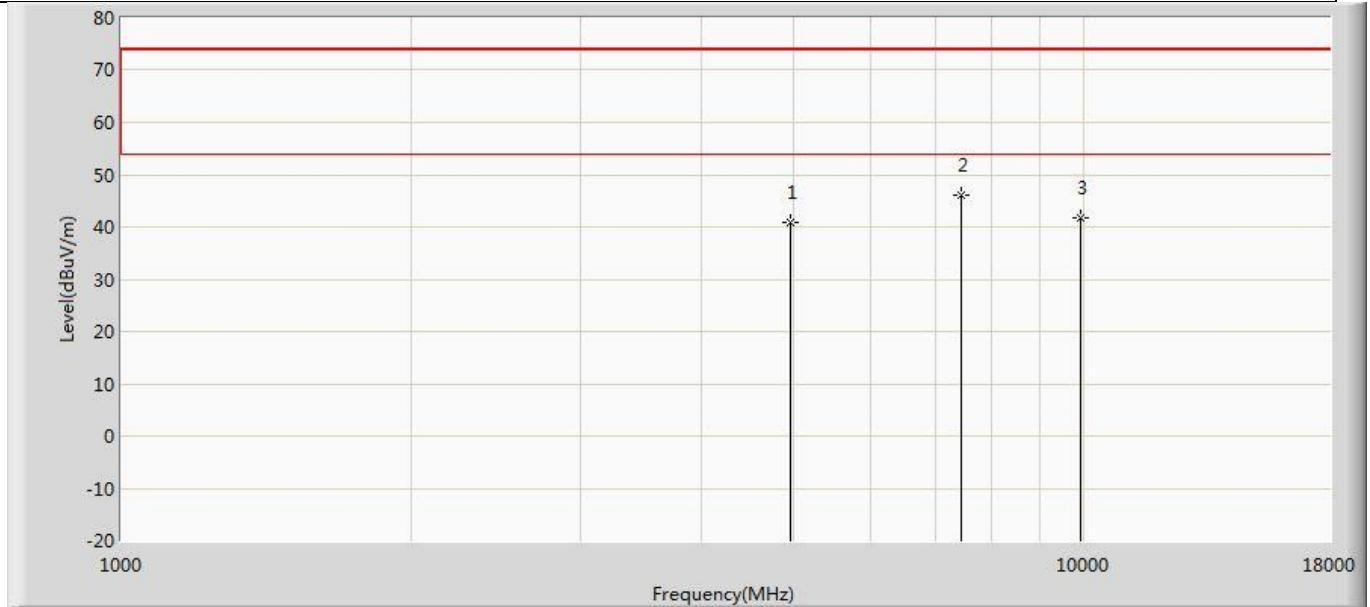

No	Mark	Frequency (MHz)	Measure Level (dBuV/m)	Reading Level (dBuV)	Over Limit (dB)	Limit (dBuV/m)	Factor (dB)	Type
1		4960.000	40.939	36.542	-33.061	74.000	4.397	PK
2	*	7443.000	46.087	38.166	-27.913	74.000	7.920	PK
3		9920.000	41.867	32.512	-32.133	74.000	9.354	PK

Profile: 2210382R	Page No.: 50
Engineer: Tongben	
Site: AC5	Time: 2022/02/08 - 22:57
Limit: FCC_Part15.209_RE(3m)	Margin: 0
Probe: Horn_3117_00167055(1-18GHz)	Polarity: Vertical
EUT: LED device	Power: AC 120V/60Hz
Note: Mode 2:Transmit at 2480MHz by 2LE	

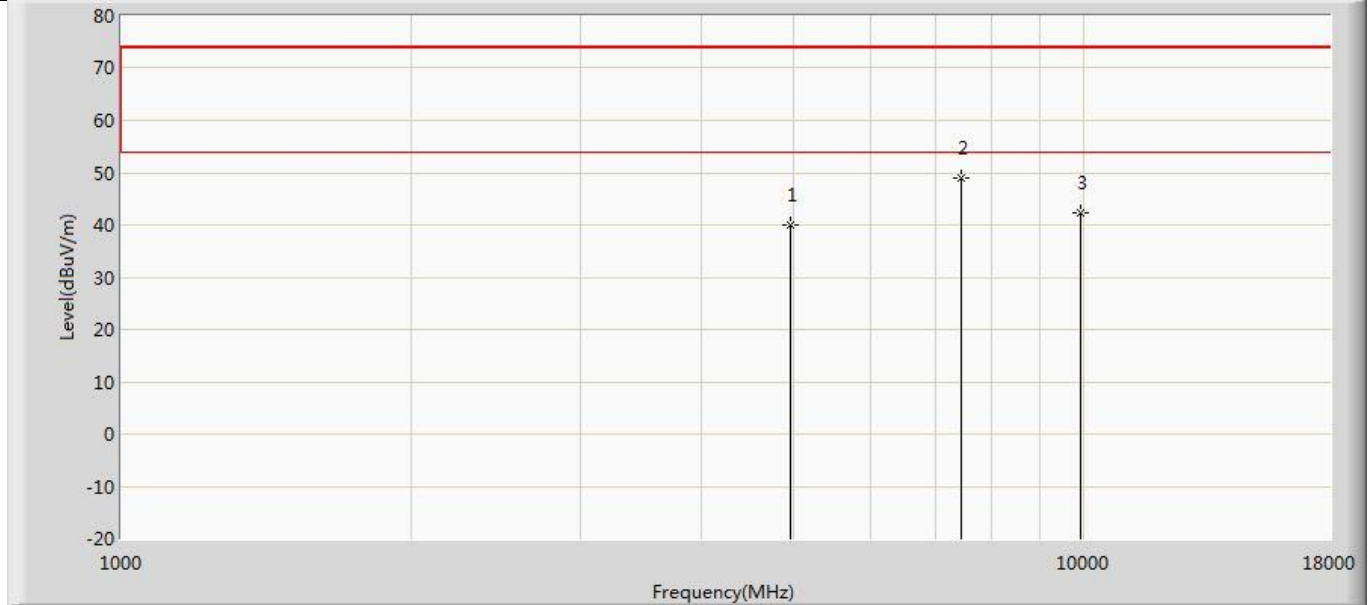

No	Mark	Frequency (MHz)	Measure Level (dBuV/m)	Reading Level (dBuV)	Over Limit (dB)	Limit (dBuV/m)	Factor (dB)	Type
1		4960.000	40.050	35.653	-33.950	74.000	4.397	PK
2	*	7443.000	48.930	41.009	-25.070	74.000	7.920	PK
3		9920.000	42.256	32.901	-31.744	74.000	9.354	PK

Profile: 2210382R	Page No.: 35
Engineer: Tongben	
Site: AC5	Time: 2022/02/08 - 22:56
Limit: FCC_Part15.209_RE(3m)	Margin: 0
Probe: Horn_3117_00167055(1-18GHz)	Polarity: Horizontal
EUT: LED device	Power: AC 120V/60Hz
Note: Mode 3:Transmit at 2402MHz by Code2	

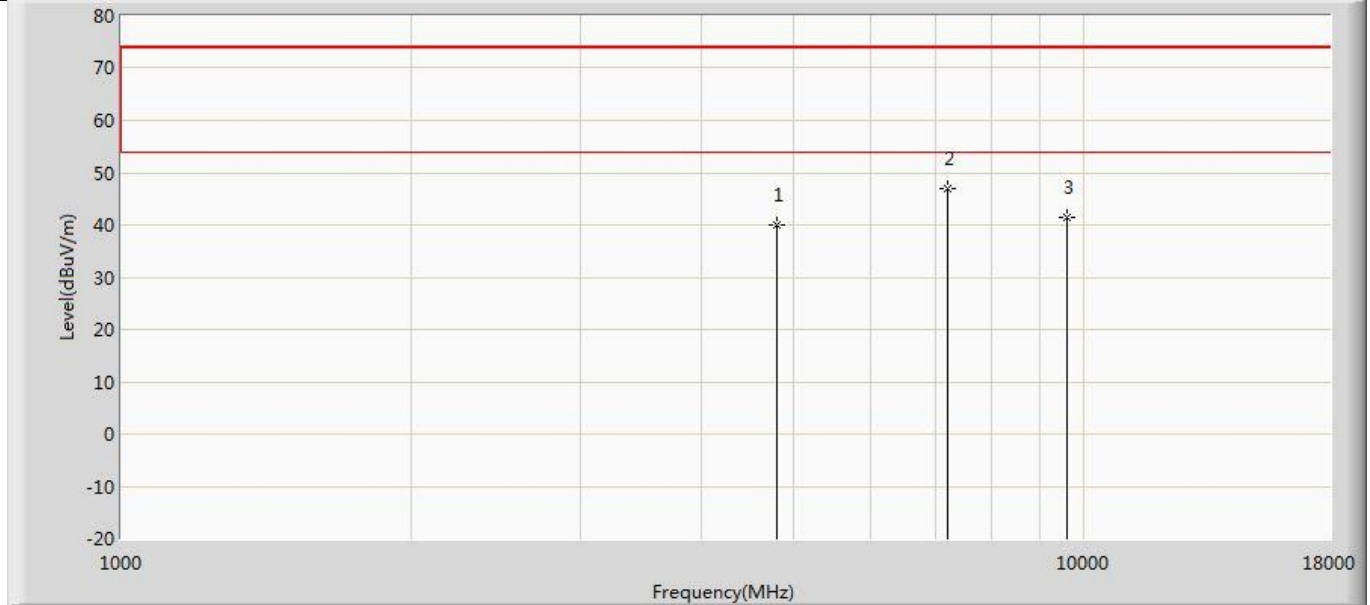

No	Mark	Frequency (MHz)	Measure Level (dBuV/m)	Reading Level (dBuV)	Over Limit (dB)	Limit (dBuV/m)	Factor (dB)	Type
1		4804.000	40.028	35.772	-33.972	74.000	4.256	PK
2	*	7205.000	46.919	39.212	-27.081	74.000	7.707	PK
3		9608.000	41.401	32.352	-32.599	74.000	9.050	PK

Profile: 2210382R	Page No.: 36
Engineer: Tongben	
Site: AC5	Time: 2022/02/08 - 22:56
Limit: FCC_Part15.209_RE(3m)	Margin: 0
Probe: Horn_3117_00167055(1-18GHz)	Polarity: Vertical
EUT: LED device	Power: AC 120V/60Hz
Note: Mode 3:Transmit at 2402MHz by Code2	

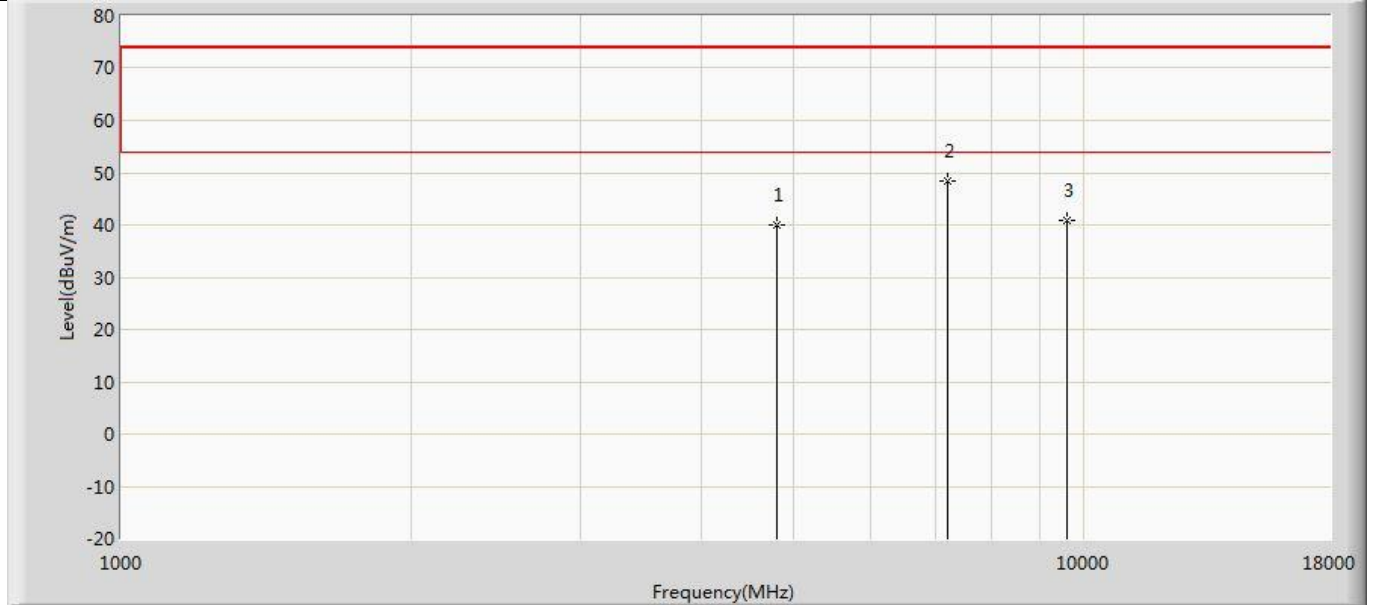

No	Mark	Frequency (MHz)	Measure Level (dBuV/m)	Reading Level (dBuV)	Over Limit (dB)	Limit (dBuV/m)	Factor (dB)	Type
1		4804.000	39.863	35.607	-34.137	74.000	4.256	PK
2	*	7205.000	48.361	40.654	-25.639	74.000	7.707	PK
3		9608.000	40.878	31.829	-33.122	74.000	9.050	PK

Profile: 2210382R	Page No.: 43
Engineer: Tongben	
Site: AC5	Time: 2022/02/08 - 22:56
Limit: FCC_Part15.209_RE(3m)	Margin: 0
Probe: Horn_3117_00167055(1-18GHz)	Polarity: Horizontal
EUT: LED device	Power: AC 120V/60Hz
Note: Mode 3:Transmit at 2440MHz by Code2	

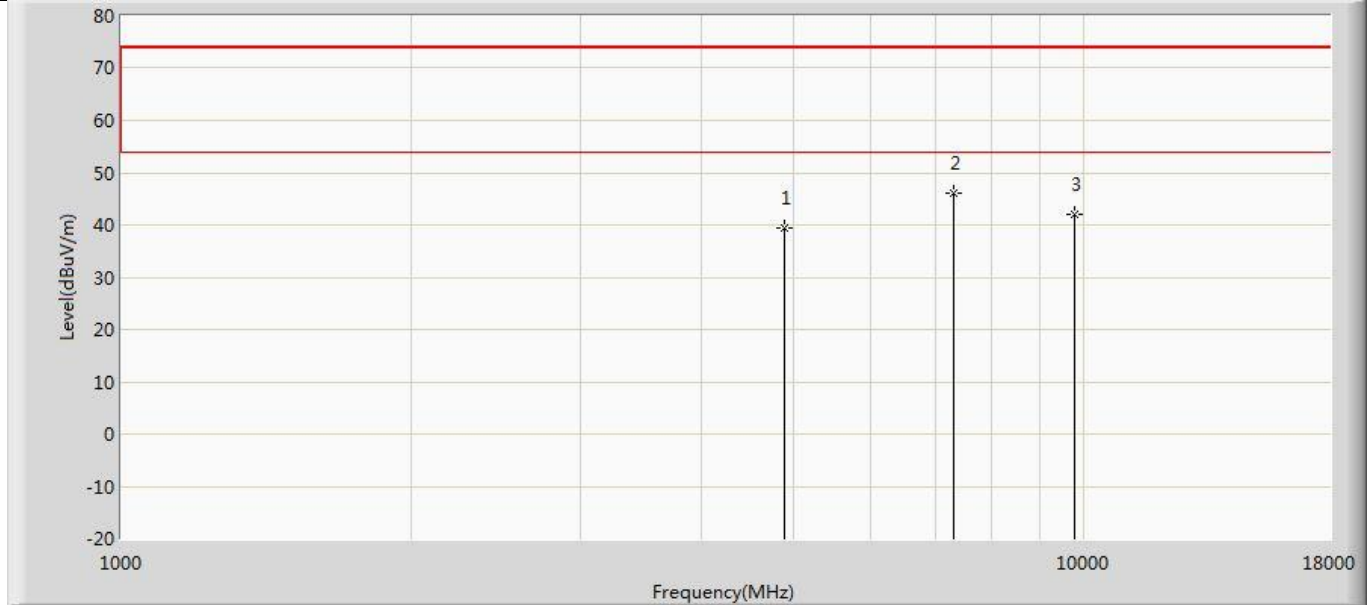

No	Mark	Frequency (MHz)	Measure Level (dBuV/m)	Reading Level (dBuV)	Over Limit (dB)	Limit (dBuV/m)	Factor (dB)	Type
1		4880.000	39.299	34.874	-34.701	74.000	4.425	PK
2	*	7315.500	46.032	38.182	-27.968	74.000	7.850	PK
3		9760.000	42.060	32.769	-31.940	74.000	9.291	PK



Profile: 2210382R	Page No.: 44
Engineer: Tongben	
Site: AC5	Time: 2022/02/08 - 22:56
Limit: FCC_Part15.209_RE(3m)	Margin: 0
Probe: Horn_3117_00167055(1-18GHz)	Polarity: Vertical
EUT: LED device	Power: AC 120V/60Hz
Note: Mode 3:Transmit at 2440MHz by Code2	

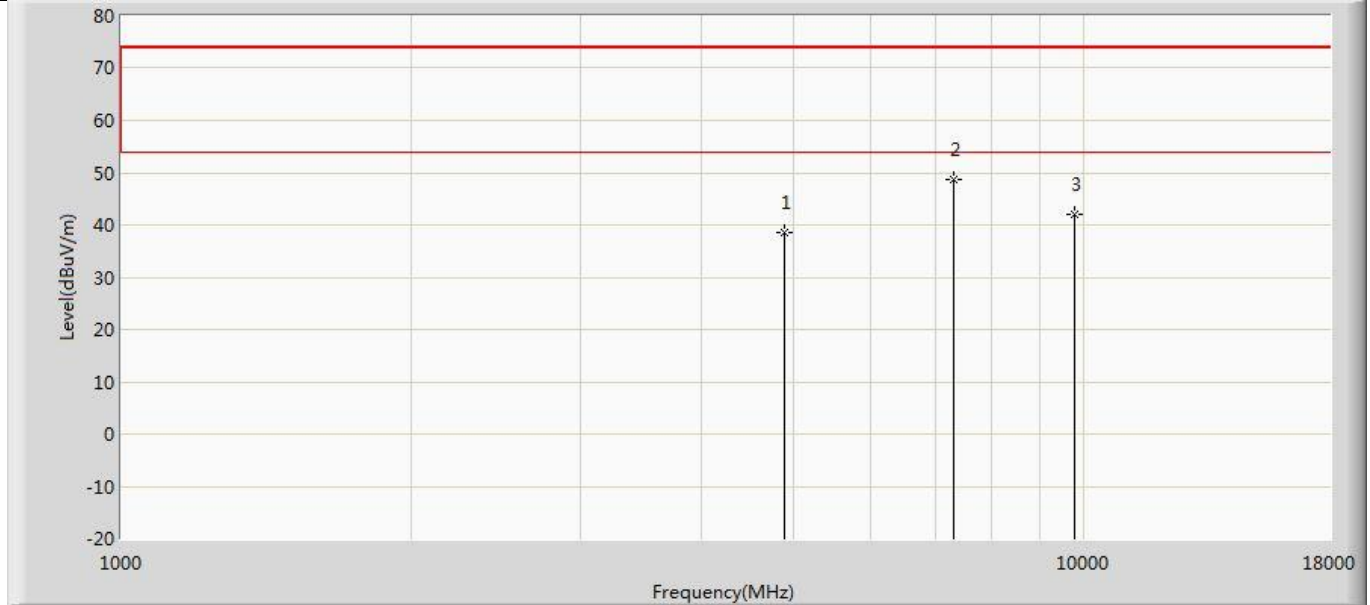

No	Mark	Frequency (MHz)	Measure Level (dBuV/m)	Reading Level (dBuV)	Over Limit (dB)	Limit (dBuV/m)	Factor (dB)	Type
1		4880.000	38.522	34.097	-35.478	74.000	4.425	PK
2	*	7315.500	48.685	40.835	-25.315	74.000	7.850	PK
3		9760.000	42.065	32.774	-31.935	74.000	9.291	PK

Profile: 2210382R	Page No.: 51
Engineer: Tongben	
Site: AC5	Time: 2022/02/08 - 22:57
Limit: FCC_Part15.209_RE(3m)	Margin: 0
Probe: Horn_3117_00167055(1-18GHz)	Polarity: Horizontal
EUT: LED device	Power: AC 120V/60Hz
Note: Mode 3:Transmit at 2480MHz by Code2	

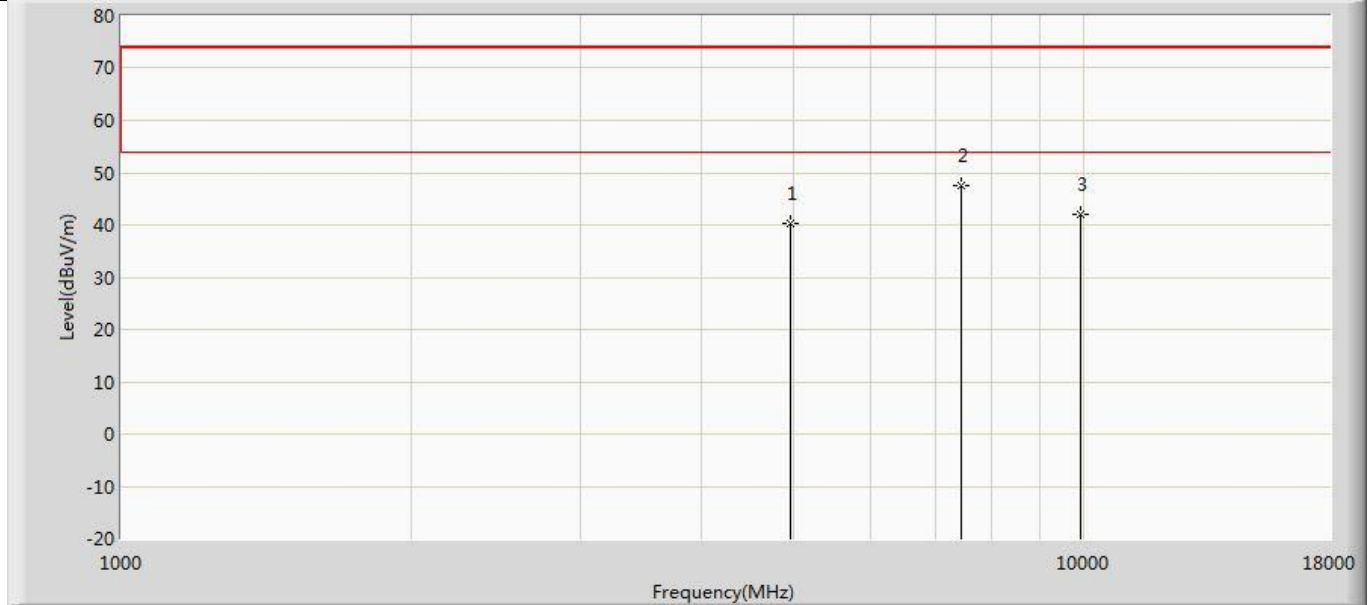

No	Mark	Frequency (MHz)	Measure Level (dBuV/m)	Reading Level (dBuV)	Over Limit (dB)	Limit (dBuV/m)	Factor (dB)	Type
1		4960.000	40.399	36.002	-33.601	74.000	4.397	PK
2	*	7443.000	47.411	39.490	-26.589	74.000	7.920	PK
3		9920.000	41.891	32.536	-32.109	74.000	9.354	PK

Profile: 2210382R	Page No.: 52
Engineer: Tongben	
Site: AC5	Time: 2022/02/08 - 22:57
Limit: FCC_Part15.209_RE(3m)	Margin: 0
Probe: Horn_3117_00167055(1-18GHz)	Polarity: Vertical
EUT: LED device	Power: AC 120V/60Hz
Note: Mode 3:Transmit at 2480MHz by Code2	

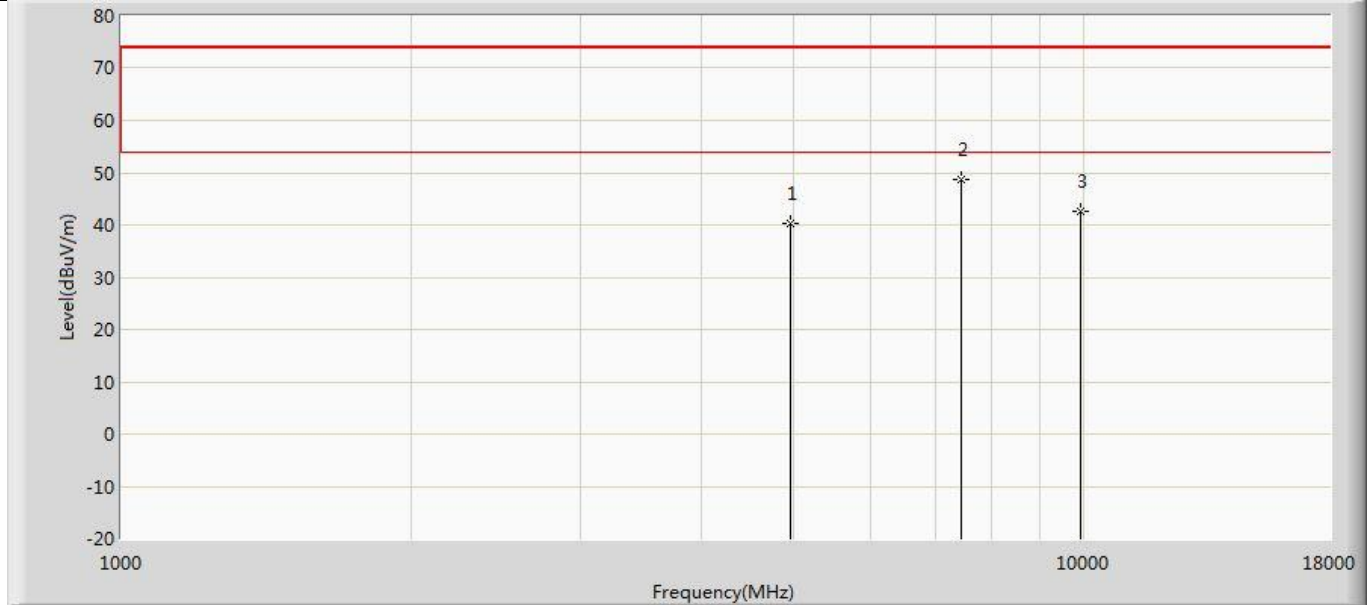

No	Mark	Frequency (MHz)	Measure Level (dBuV/m)	Reading Level (dBuV)	Over Limit (dB)	Limit (dBuV/m)	Factor (dB)	Type
1		4960.000	40.383	35.986	-33.617	74.000	4.397	PK
2	*	7443.000	48.824	40.903	-25.176	74.000	7.920	PK
3		9920.000	42.656	33.301	-31.344	74.000	9.354	PK

Profile: 2210382R	Page No.: 37
Engineer: Tongben	
Site: AC5	Time: 2022/02/08 - 22:56
Limit: FCC_Part15.209_RE(3m)	Margin: 0
Probe: Horn_3117_00167055(1-18GHz)	Polarity: Horizontal
EUT: LED device	Power: AC 120V/60Hz
Note: Mode 4:Transmit at 2402MHz by Code8	

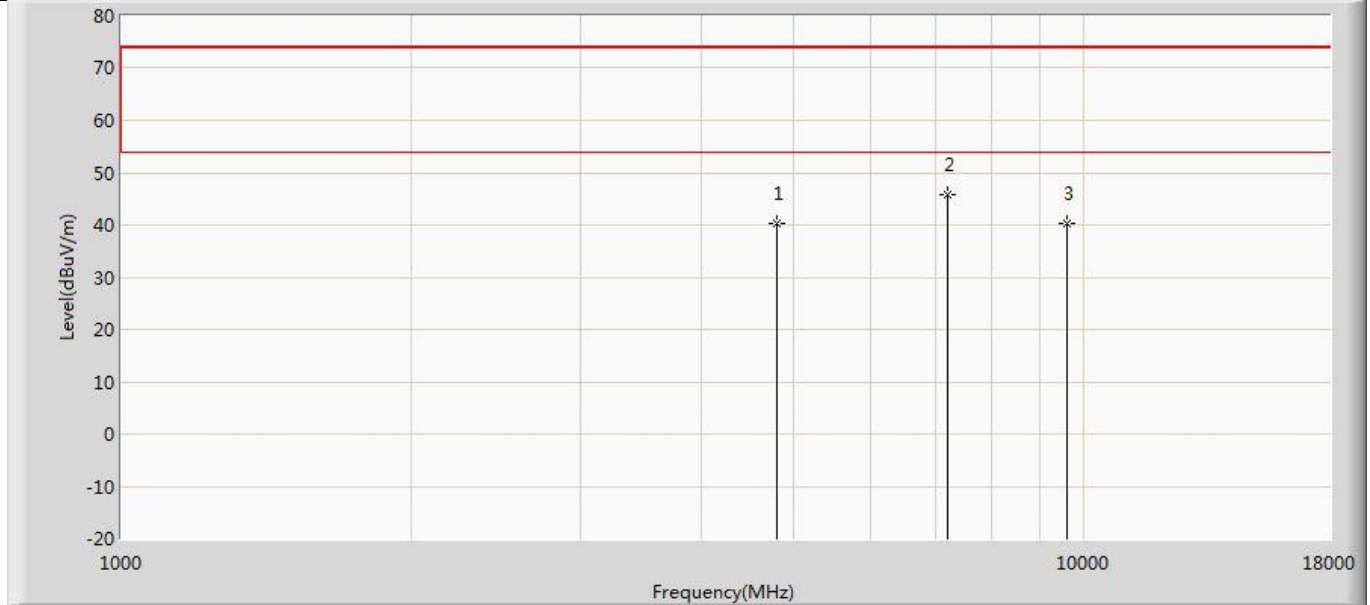

No	Mark	Frequency (MHz)	Measure Level (dBuV/m)	Reading Level (dBuV)	Over Limit (dB)	Limit (dBuV/m)	Factor (dB)	Type
1		4804.000	40.207	35.951	-33.793	74.000	4.256	PK
2	*	7205.000	45.658	37.951	-28.342	74.000	7.707	PK
3		9608.000	40.328	31.279	-33.672	74.000	9.050	PK

Profile: 2210382R	Page No.: 38
Engineer: Tongben	
Site: AC5	Time: 2022/02/08 - 22:56
Limit: FCC_Part15.209_RE(3m)	Margin: 0
Probe: Horn_3117_00167055(1-18GHz)	Polarity: Vertical
EUT: LED device	Power: AC 120V/60Hz
Note: Mode 4:Transmit at 2402MHz by Code8	

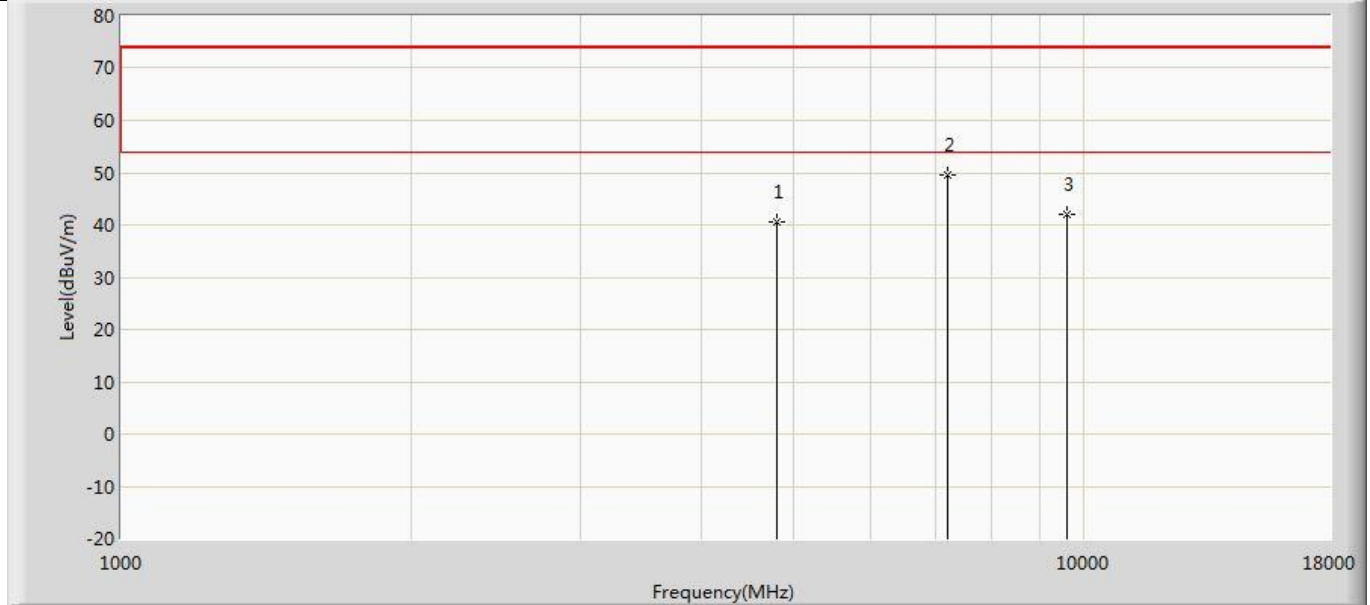

No	Mark	Frequency (MHz)	Measure Level (dBuV/m)	Reading Level (dBuV)	Over Limit (dB)	Limit (dBuV/m)	Factor (dB)	Type
1		4804.000	40.642	36.386	-33.358	74.000	4.256	PK
2	*	7205.000	49.471	41.764	-24.529	74.000	7.707	PK
3		9608.000	42.032	32.983	-31.968	74.000	9.050	PK

Profile: 2210382R	Page No.: 45
Engineer: Tongben	
Site: AC5	Time: 2022/02/08 - 22:56
Limit: FCC_Part15.209_RE(3m)	Margin: 0
Probe: Horn_3117_00167055(1-18GHz)	Polarity: Horizontal
EUT: LED device	Power: AC 120V/60Hz
Note: Mode 4:Transmit at 2440MHz by Code8	

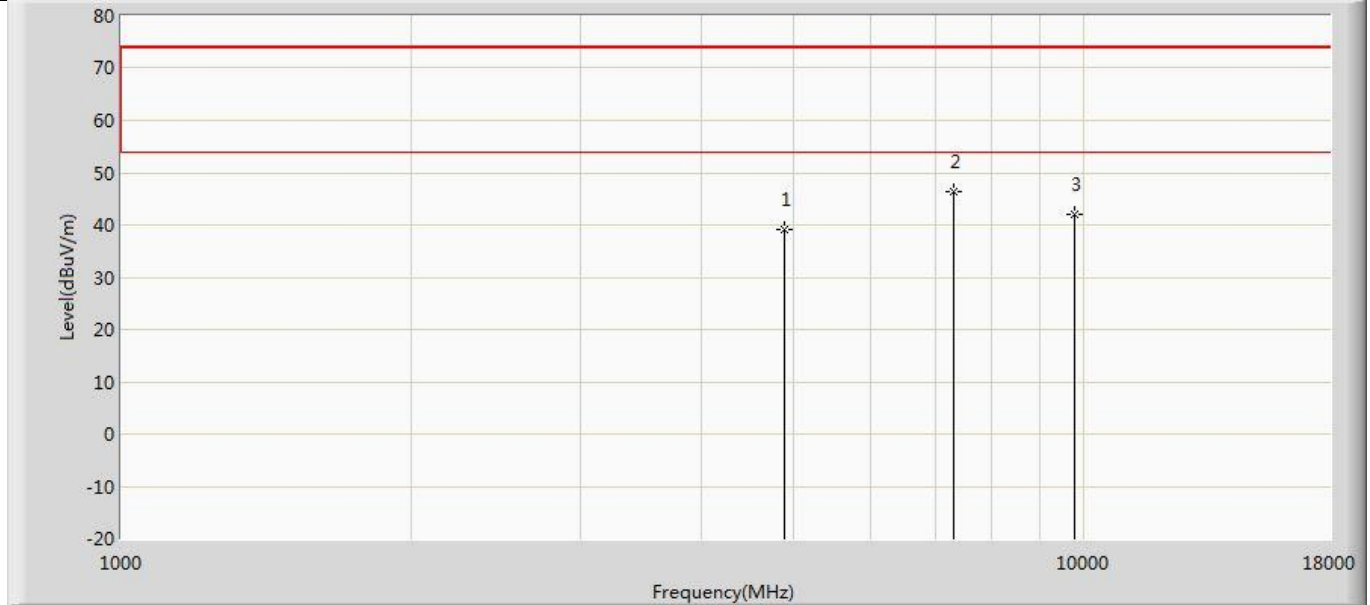

No	Mark	Frequency (MHz)	Measure Level (dBuV/m)	Reading Level (dBuV)	Over Limit (dB)	Limit (dBuV/m)	Factor (dB)	Type
1		4880.000	39.079	34.654	-34.921	74.000	4.425	PK
2	*	7315.500	46.373	38.523	-27.627	74.000	7.850	PK
3		9760.000	41.891	32.600	-32.109	74.000	9.291	PK

Profile: 2210382R	Page No.: 46
Engineer: Tongben	
Site: AC5	Time: 2022/02/08 - 22:56
Limit: FCC_Part15.209_RE(3m)	Margin: 0
Probe: Horn_3117_00167055(1-18GHz)	Polarity: Vertical
EUT: LED device	Power: AC 120V/60Hz
Note: Mode 4:Transmit at 2440MHz by Code8	

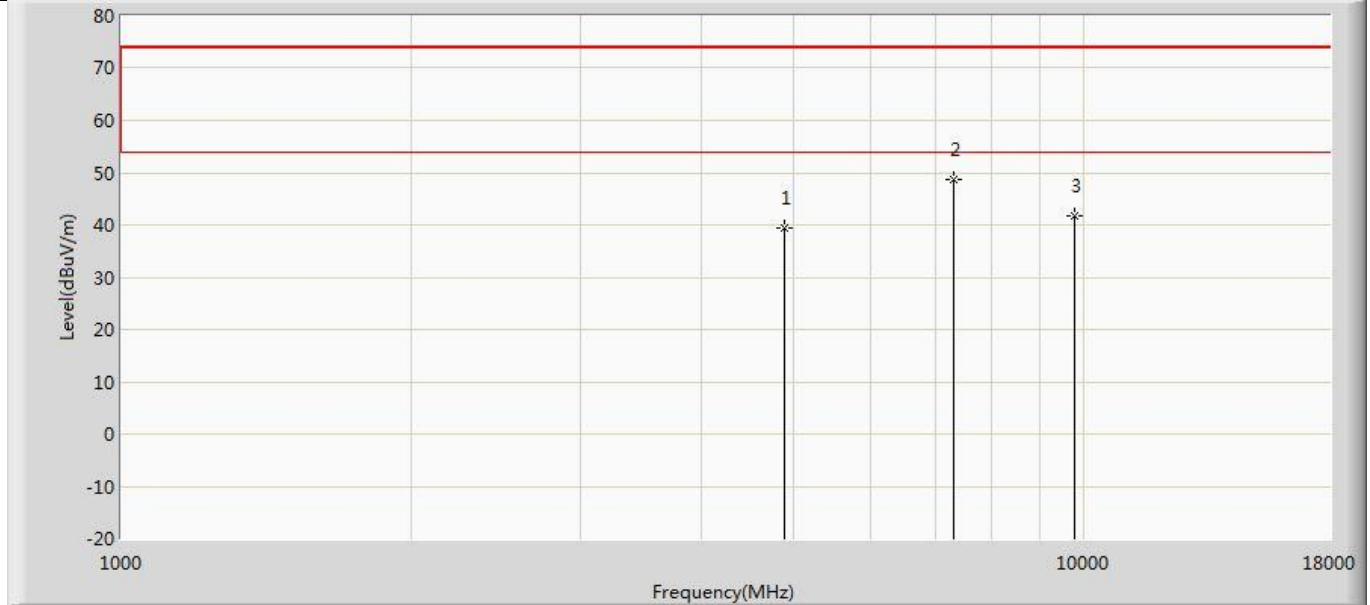

No	Mark	Frequency (MHz)	Measure Level (dBuV/m)	Reading Level (dBuV)	Over Limit (dB)	Limit (dBuV/m)	Factor (dB)	Type
1		4880.000	39.353	34.928	-34.647	74.000	4.425	PK
2	*	7315.500	48.622	40.772	-25.378	74.000	7.850	PK
3		9760.000	41.597	32.306	-32.403	74.000	9.291	PK

Profile: 2210382R	Page No.: 53
Engineer: Tongben	
Site: AC5	Time: 2022/02/08 - 22:57
Limit: FCC_Part15.209_RE(3m)	Margin: 0
Probe: Horn_3117_00167055(1-18GHz)	Polarity: Horizontal
EUT: LED device	Power: AC 120V/60Hz
Note: Mode 4:Transmit at 2480MHz by Code8	

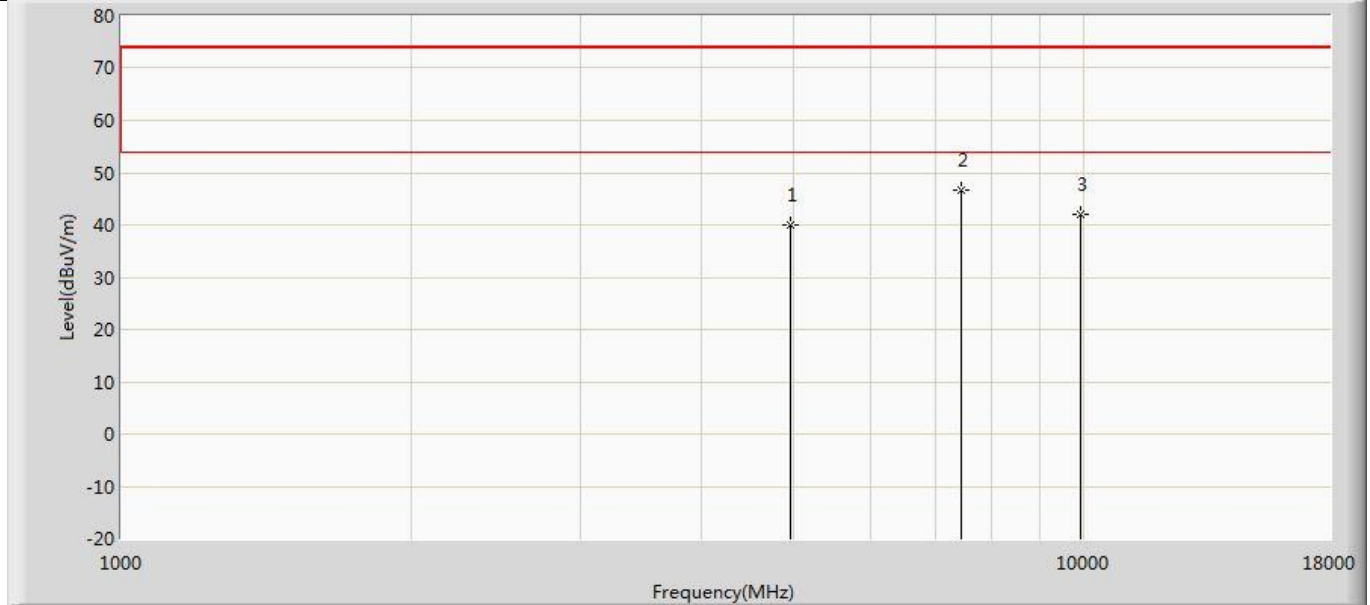

No	Mark	Frequency (MHz)	Measure Level (dBuV/m)	Reading Level (dBuV)	Over Limit (dB)	Limit (dBuV/m)	Factor (dB)	Type
1		4960.000	39.994	35.597	-34.006	74.000	4.397	PK
2	*	7443.000	46.591	38.670	-27.409	74.000	7.920	PK
3		9920.000	42.031	32.676	-31.969	74.000	9.354	PK



Profile: 2210382R	Page No.: 54
Engineer: Tongben	
Site: AC5	Time: 2022/02/08 - 22:57
Limit: FCC_Part15.209_RE(3m)	Margin: 0
Probe: Horn_3117_00167055(1-18GHz)	Polarity: Vertical
EUT: LED device	Power: AC 120V/60Hz
Note: Mode 4:Transmit at 2480MHz by Code8	

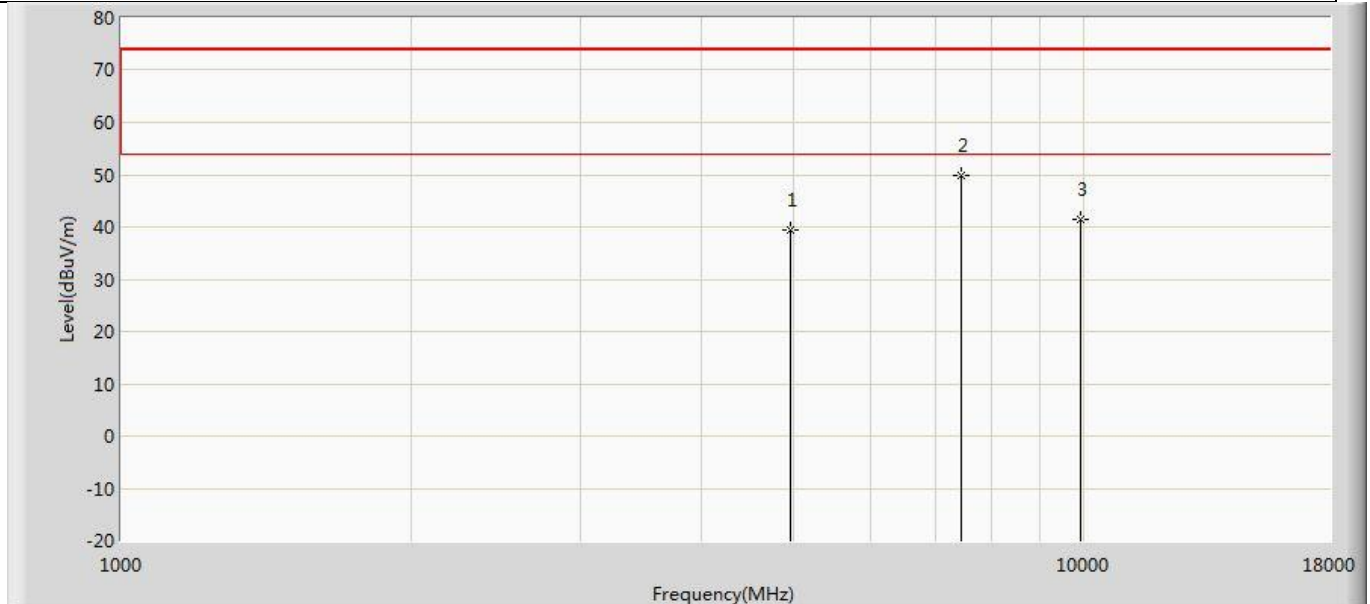

No	Mark	Frequency (MHz)	Measure Level (dBuV/m)	Reading Level (dBuV)	Over Limit (dB)	Limit (dBuV/m)	Factor (dB)	Type
1		4960.000	39.293	34.896	-34.707	74.000	4.397	PK
2	*	7443.000	49.778	41.857	-24.222	74.000	7.920	PK
3		9920.000	41.437	32.082	-32.563	74.000	9.354	PK

Note:

1. Measured Level = Reading Level + Factor.
2. The test frequency range, 9kHz~30MHz, worst case are at least 20dB below the limits, therefore no data appear in the report.
3. The test frequency range, 18GHz~26GHz test result on peak is lower than average limit, all is the noise base, therefore no data appear in the report.
4. This limit applies for using average detector, if the test result on peak is lower than average limit, then average measurement needn't be performed.
5. As the radiated emission was performed, so conducted emission was not tested.

**The worst case of Radiated Emission below 1GHz:**

Profile: 2210382R	Page No.: 1
Engineer: Yin Feiwang	
Site: AC2	Time: 2022/02/15 - 02:57
Limit: FCC_Part15.209_RE(3m)	Margin: 4
Probe: AC2_3M(30-1000M)	Polarity: Horizontal
EUT: LED device	Power: AC 120V/60Hz
Note: Mode1	

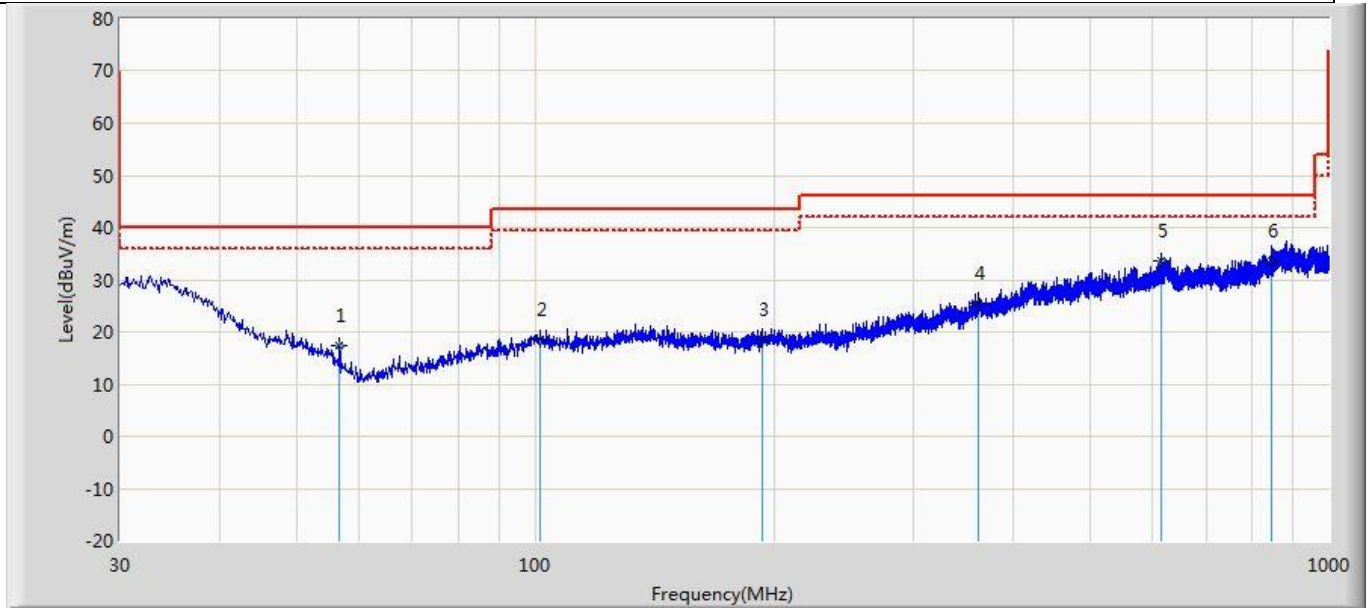

No	Mark	Frequency (MHz)	Measure Level (dBuV/m)	Reading Level (dBuV)	Over Limit (dB)	Limit (dBuV/m)	Factor (dB)	Type
1		56.675	17.498	5.561	-22.502	40.000	11.937	QP
2		101.537	18.467	1.434	-25.033	43.500	17.033	QP
3		192.960	18.679	1.406	-24.821	43.500	17.273	QP
4		361.861	25.498	1.223	-20.502	46.000	24.276	QP
5		614.667	33.485	3.718	-12.515	46.000	29.767	QP
6	*	846.740	33.589	2.292	-12.411	46.000	31.297	QP

**Note:**

1. All Readings below 1GHz are Quasi-Peak, above are performed with peak and/or average measurements as necessary.
2. " \* ", means this data is the worst emission level.
3. Measurement Level = Reading Level + Factor(Probe+Cable-Amp)

Profile: 2210382R	Page No.: 2
Engineer: Yin Feiwang	
Site: AC2	Time: 2022/02/15 - 02:59
Limit: FCC_Part15.209_RE(3m)	Margin: 4
Probe: AC2_3M(30-1000M)	Polarity: Vertical
EUT: LED device	Power: AC 120V/60Hz
Note: Mode1	

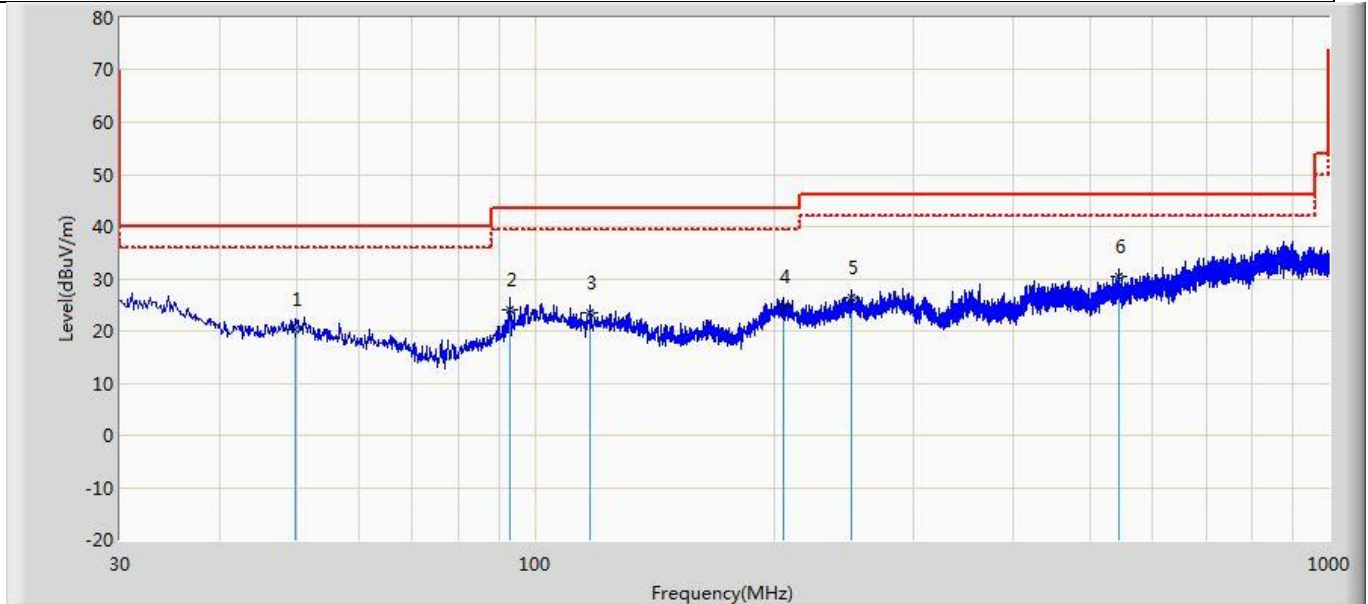

No	Mark	Frequency (MHz)	Measure Level (dBuV/m)	Reading Level (dBuV)	Over Limit (dB)	Limit (dBuV/m)	Factor (dB)	Type
1		49.885	20.167	0.763	-19.833	40.000	19.404	QP
2		92.808	24.168	5.699	-19.332	43.500	18.470	QP
3		117.300	23.468	3.050	-20.032	43.500	20.418	QP
4		205.085	24.648	1.223	-18.852	43.500	23.425	QP
5		249.947	26.469	2.034	-19.531	46.000	24.434	QP
6	*	543.979	30.469	3.650	-15.531	46.000	26.819	QP

Note:

1. All Readings below 1GHz are Quasi-Peak, above are performed with peak and/or average measurements as necessary.
2. " \* ", means this data is the worst emission level.
3. Measurement Level = Reading Level + Factor(Probe+Cable-Amp)

<b>4.3 Emissions in non-restricted frequency band</b>	<b>VERDICT: PASS</b>
---	----------------------

4.3.1 Limit	
<b>Standard</b>	FCC Part 15 Subpart C Paragraph 15.247(d)
RF Output power (Detection methods)	Limit(dB)
RF Output power(Average detector)	30dBc(Note1)
RF Output power(PK detector)	20dBc(Note2)
<p>Note 1: If maximum conducted (average) output power was used to demonstrate compliance as described in 9.2, then the peak power in any 100 kHz bandwidth outside of the authorized frequency band shall be attenuated by at least 30 dB relative to the maximum in-band peak PSD level in 100 kHz (i.e., 30 dBc).</p> <p>Note 2: If the maximum peak conducted output power procedure was used, then the peak output power measured in any 100 kHz bandwidth outside of the authorized frequency band shall be attenuated by at least 20 dB relative to the maximum in-band peak PSD level in 100 kHz (i.e., 20 dBc).</p>	

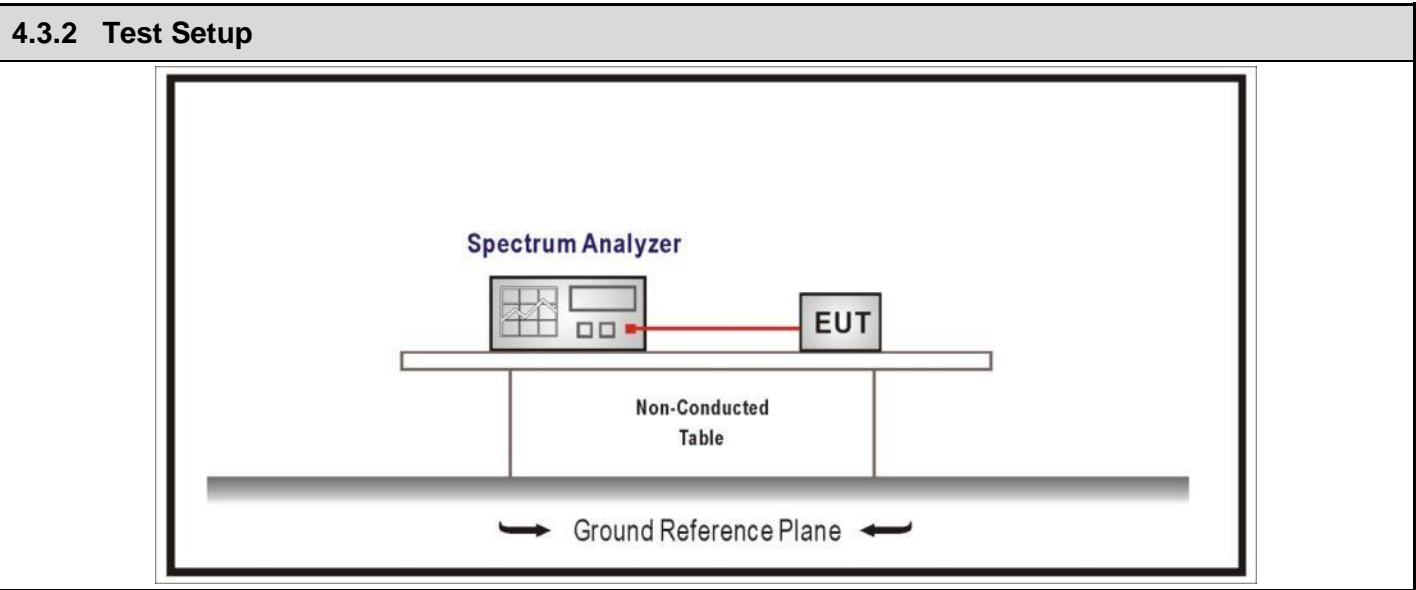

4.3.3 Test Procedure			
References Rule	Chapter	Description	
<input checked="" type="checkbox"/>	ANSI C63.10	11.11	Emissions in non-restricted frequency bands
<input checked="" type="checkbox"/>	ANSI C63.10	11.11.1	General
<input checked="" type="checkbox"/>	ANSI C63.10	11.11.2	Reference level measurement
<input checked="" type="checkbox"/>	ANSI C63.10	11.11.3	Emission level measurement

### 4.3.4 Test Data

Mode	Channel	Test Frequency (MHz)	Maximum In-Band PSD[a] (dBm/100kHz)	Frequency (MHz)	Out-Band PSD[b] (dBm/100kHz)	[a]-[b] (dB)	Limit (dB)	Result
1	00	2402	9.597	2400	-41.18	50.777	≥20	Pass
	39	2480	9.366	2518.397	-53.99	63.356	≥20	Pass
2	00	2402	7.597	2400	-22.15	29.747	≥20	Pass
	39	2480	7.358	2518.199	-57.55	64.908	≥20	Pass
3	00	2402	9.532	2400	-40.90	50.432	≥20	Pass
	39	2480	6.557	2518.535	-58.11	64.667	≥20	Pass
4	00	2402	9.532	2400	-40.90	50.432	≥20	Pass
	39	2480	9.289	2518.26	-54.91	64.199	≥20	Pass

Note: The worst case of emissions in non-restricted frequency bands as below:

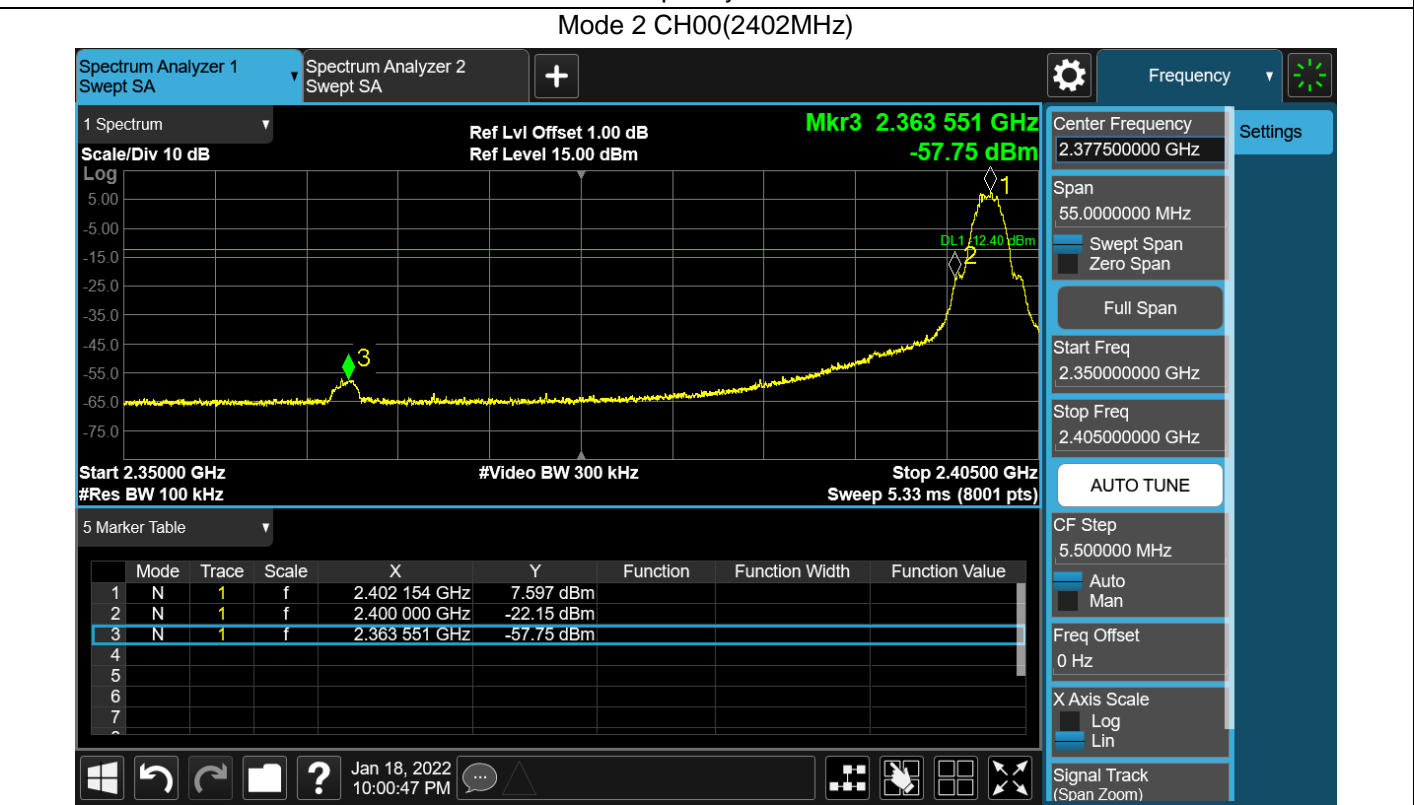

The data of entire corresponding spectrum:

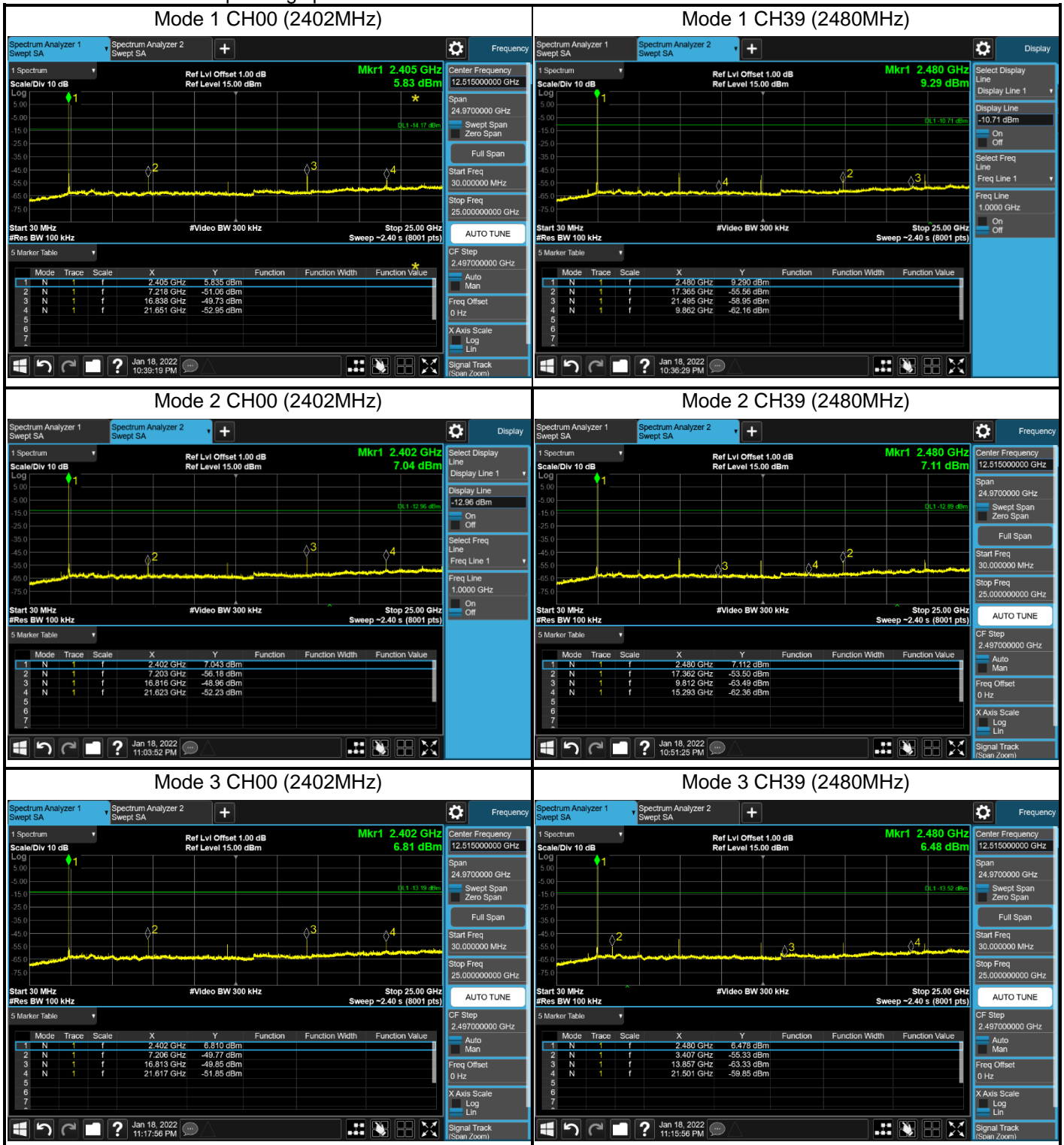

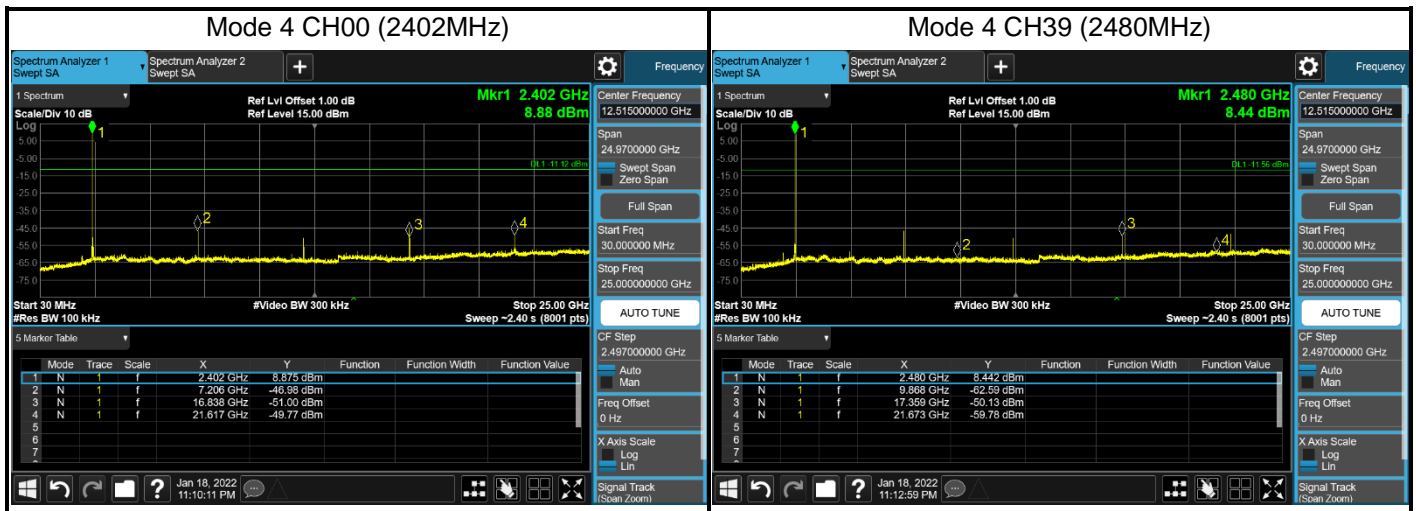

**4.4 Duty cycle**

**VERDICT: PASS**

**4.4.1 Limit**

N/A

**4.4.2 Test Setup**

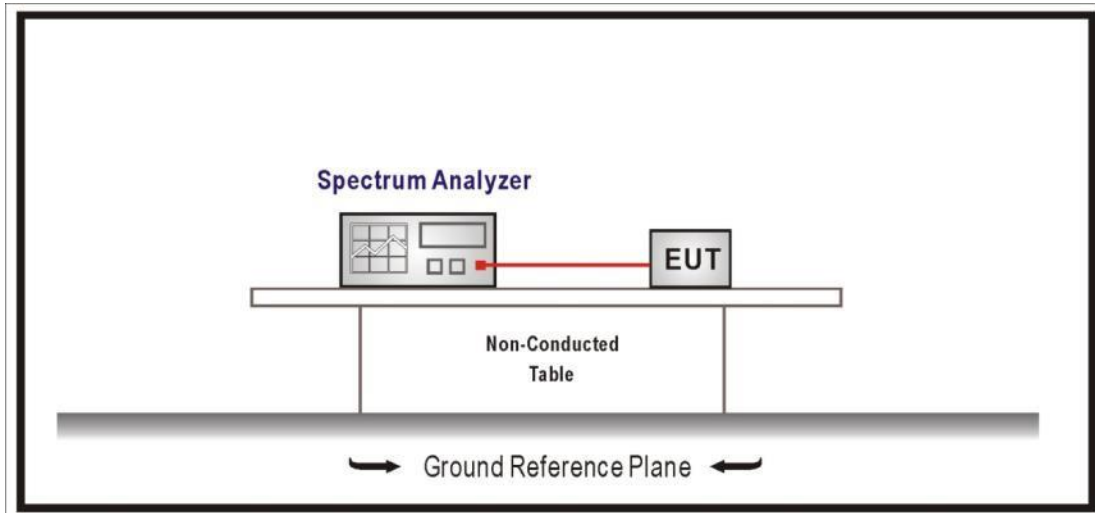

**4.4.3 Test Procedure**

References Rule	Chapter	Description
<input checked="" type="checkbox"/> ANSI C63.10	11.6	Duty cycle (D), transmission duration (T), and maximum power control level



### 4.4.4 Test Data

Test Mode	Tx On (us)	Tx Off (us)	VBW (Hz)	Tx On + Tx Off (us)	Duty Cycle (%)
Mode 1	N/A	N/A	10	N/A	100
Mode 2	N/A	N/A	10	N/A	100
Mode 3	N/A	N/A	10	N/A	100
Mode 4	N/A	N/A	10	N/A	100

Note 1: T means the minimum transmission duration over which the transmitter is on and is transmitting at its maximum power control level for the tested mode of operation.

Note 2: According to KDB 558074, when test for Radiated Emission Band Edge and Radiated Emission, for average detector set:  $VBW \geq 1/T$  will be used.

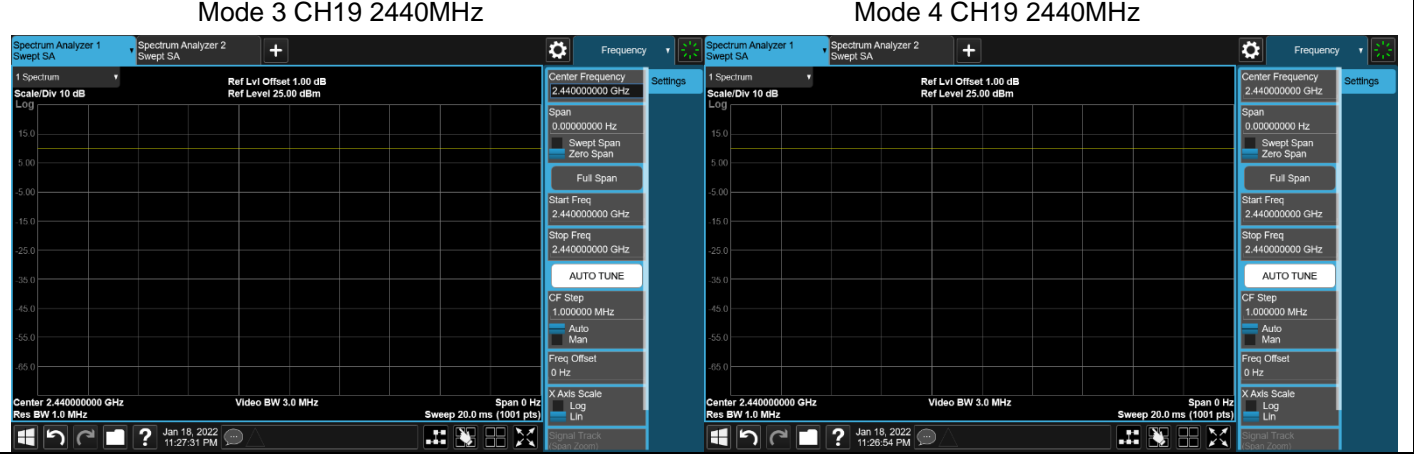

<b>4.5 Band Edge</b>	<b>VERDICT: PASS</b>
----------------------	----------------------

**4.5.1 Limit**

<b>Standard</b>		FCC Part 15 Subpart C Paragraph 15.247(d) ,15.209		
Frequency bands (MHz)	Detector	Limit (dBμV/m)	RBW (MHz)	Distance (m)
2310-2390	PK	74	1	3
2483.5-2500	AV	54	1	3

Note: The field strength of emissions appearing within these frequency bands shall not exceed the limits.

**4.5.2 Test Setup**

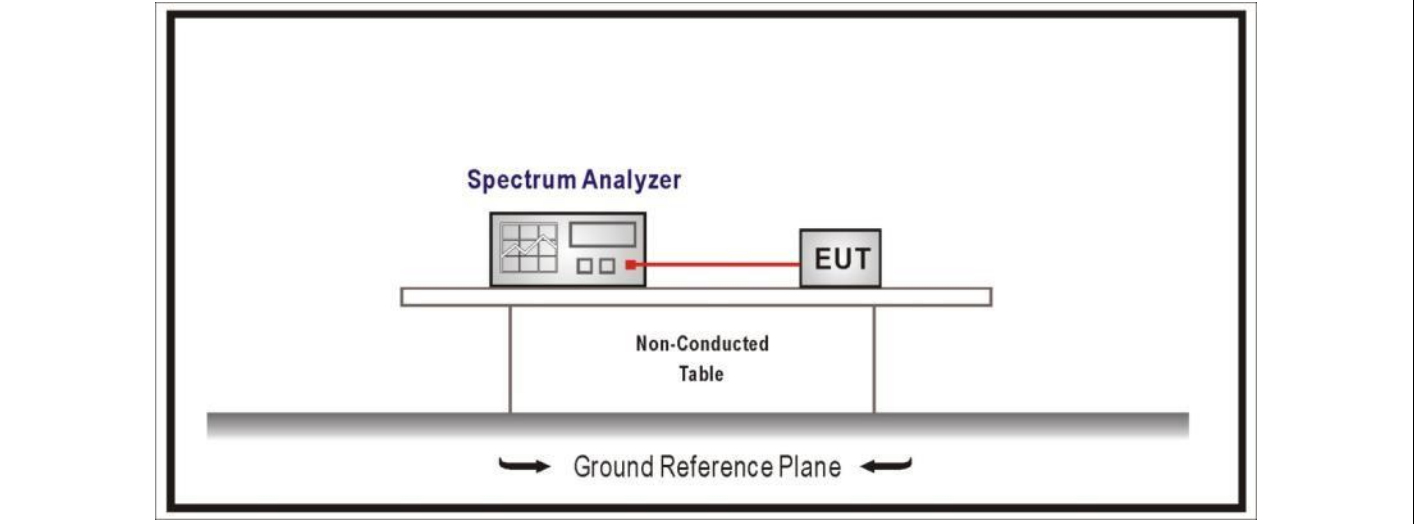

**4.5.3 Test Procedure**

	References Rule	Chapter	Description
<input checked="" type="checkbox"/>	ANSI C63.10	6.10	Band-edge testing
	<input checked="" type="checkbox"/> ANSI C63.10	6.10.5	Restricted-band band-edge measurements
	<input type="checkbox"/> ANSI C63.10	6.10.6	Marker-delta method
<input checked="" type="checkbox"/>	ANSI C63.10	11.12	Emissions in restricted frequency bands
	<input checked="" type="checkbox"/> ANSI C63.10	11.12.2	Antenna-port conducted measurements
	<input type="checkbox"/> ANSI C63.10	11.12.2.3	Quasi-peak measurement procedure
	<input checked="" type="checkbox"/> ANSI C63.10	11.12.2.4	Peak power measurement procedure
	<input checked="" type="checkbox"/> ANSI C63.10	11.12.2.5	Average power measurement procedures

**4.5.4 Test Data**

Profile: 2210382R	Page No.: 1
Engineer: YULIU	
Site: AC5	Time: 2022/02/08 - 00:39
Limit: FCC_Part15.209_RE(3m)	Margin: 0
Probe: Horn_3117_00167055(1-18GHz)	Polarity: Vertical
EUT: LED DEVICE	Power: AC 120V/60Hz
Note: Mode 1:Transmit at 2402MHz by BLE_1M	

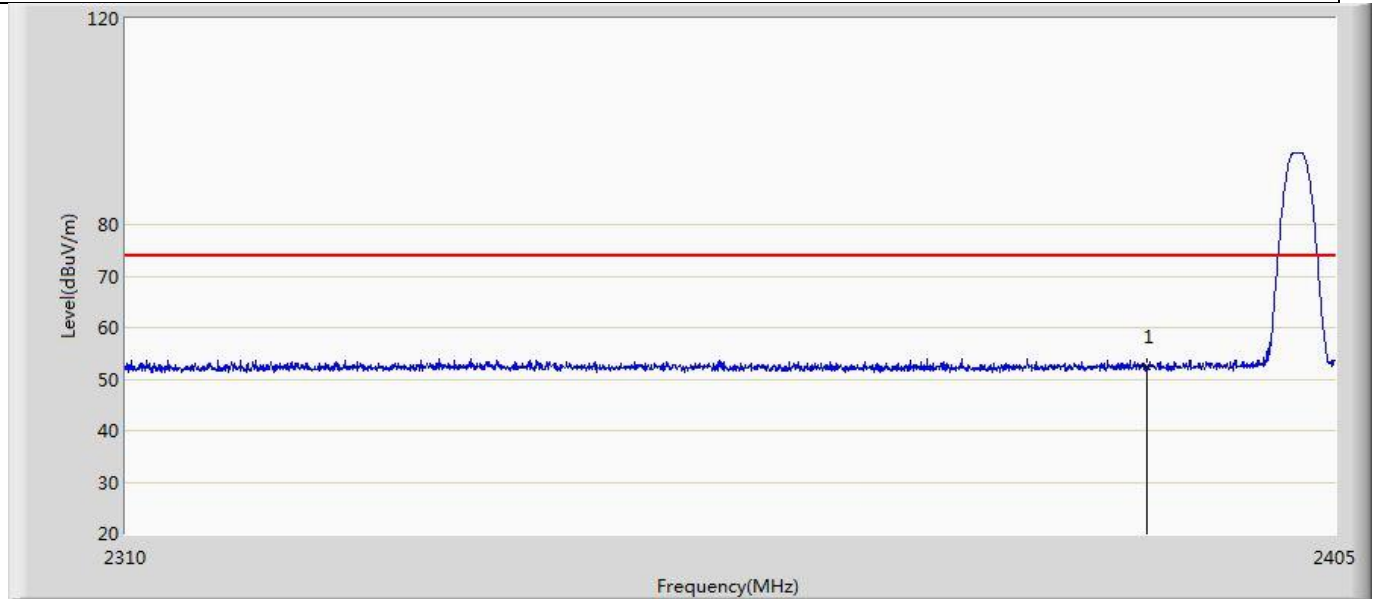

No	Mark	Frequency (MHz)	Measure Level (dBuV/m)	Reading Level (dBuV)	Over Limit (dB)	Limit (dBuV/m)	Factor (dB)	Type
1	*	2390.000	52.451	15.319	-21.549	74.000	37.133	PK

Profile: 2210382R	Page No.: 2
Engineer: YULIU	
Site: AC5	Time: 2022/02/08 - 20:21
Limit: FCC_Part15.209_RE(3m)	Margin: 0
Probe: Horn_3117_00167055(1-18GHz)	Polarity: Vertical
EUT: LED DEVICE	Power: AC 120V/60Hz
Note: Mode 1:Transmit at 2402MHz by BLE_1M	

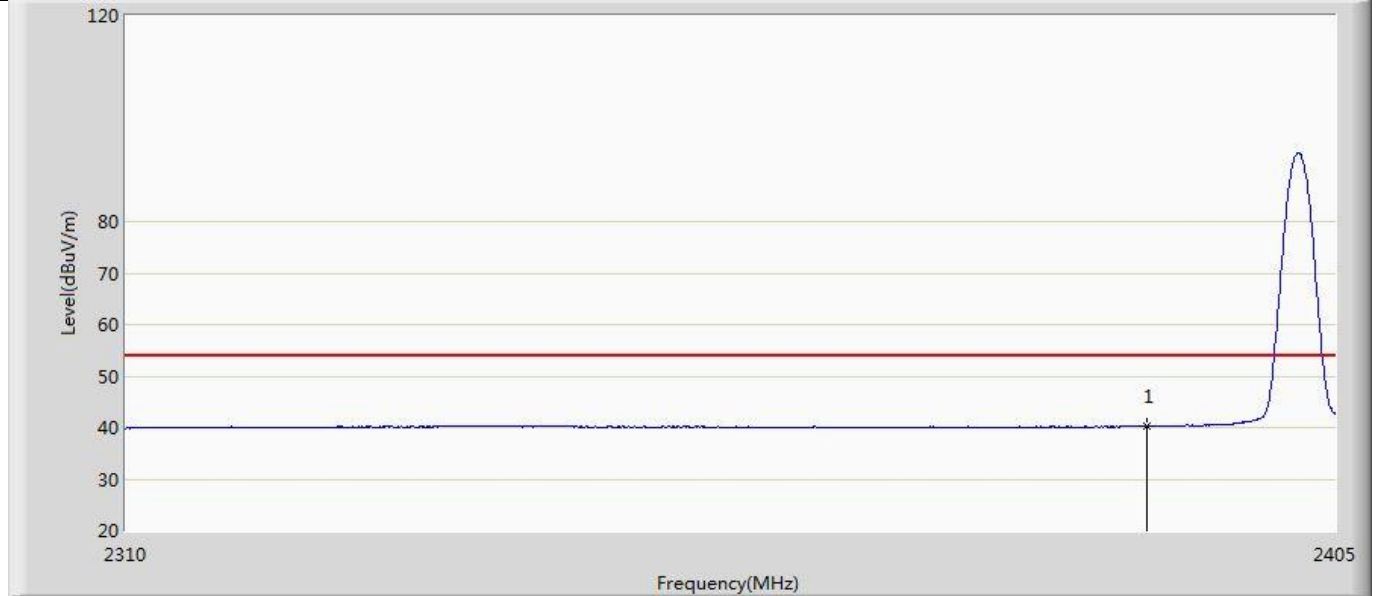

No	Mark	Frequency (MHz)	Measure Level (dBuV/m)	Reading Level (dBuV)	Over Limit (dB)	Limit (dBuV/m)	Factor (dB)	Type
1	*	2390.000	40.326	3.194	-13.674	54.000	37.133	AV

Profile: 2210382R	Page No.: 3
Engineer: YULIU	
Site: AC5	Time: 2022/02/08 - 20:24
Limit: FCC_Part15.209_RE(3m)	Margin: 0
Probe: Horn_3117_00167055(1-18GHz)	Polarity: Horizontal
EUT: LED DEVICE	Power: AC 120V/60Hz
Note: Mode 1:Transmit at 2402MHz by BLE_1M	

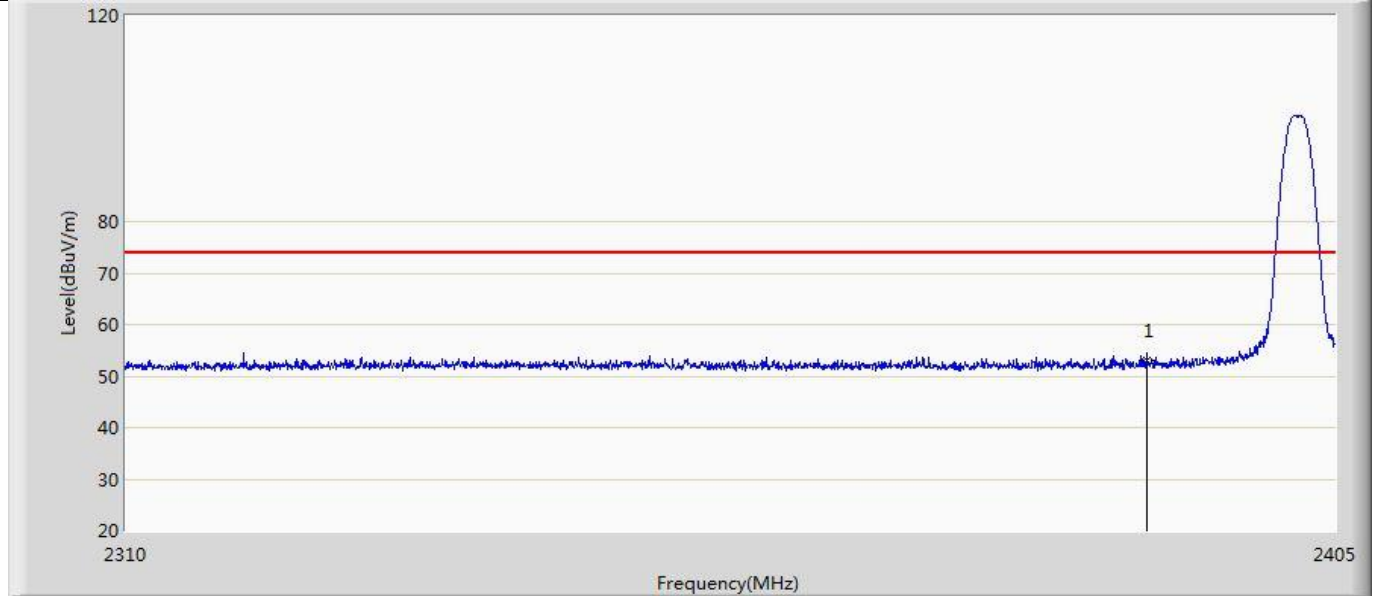

No	Mark	Frequency (MHz)	Measure Level (dBuV/m)	Reading Level (dBuV)	Over Limit (dB)	Limit (dBuV/m)	Factor (dB)	Type
1	*	2390.000	53.159	16.027	-20.841	74.000	37.133	PK

Profile: 2210382R	Page No.: 4
Engineer: YULIU	
Site: AC5	Time: 2022/02/08 - 20:26
Limit: FCC_Part15.209_RE(3m)	Margin: 0
Probe: Horn_3117_00167055(1-18GHz)	Polarity: Horizontal
EUT: LED DEVICE	Power: AC 120V/60Hz
Note: Mode 1:Transmit at 2402MHz by BLE_1M	

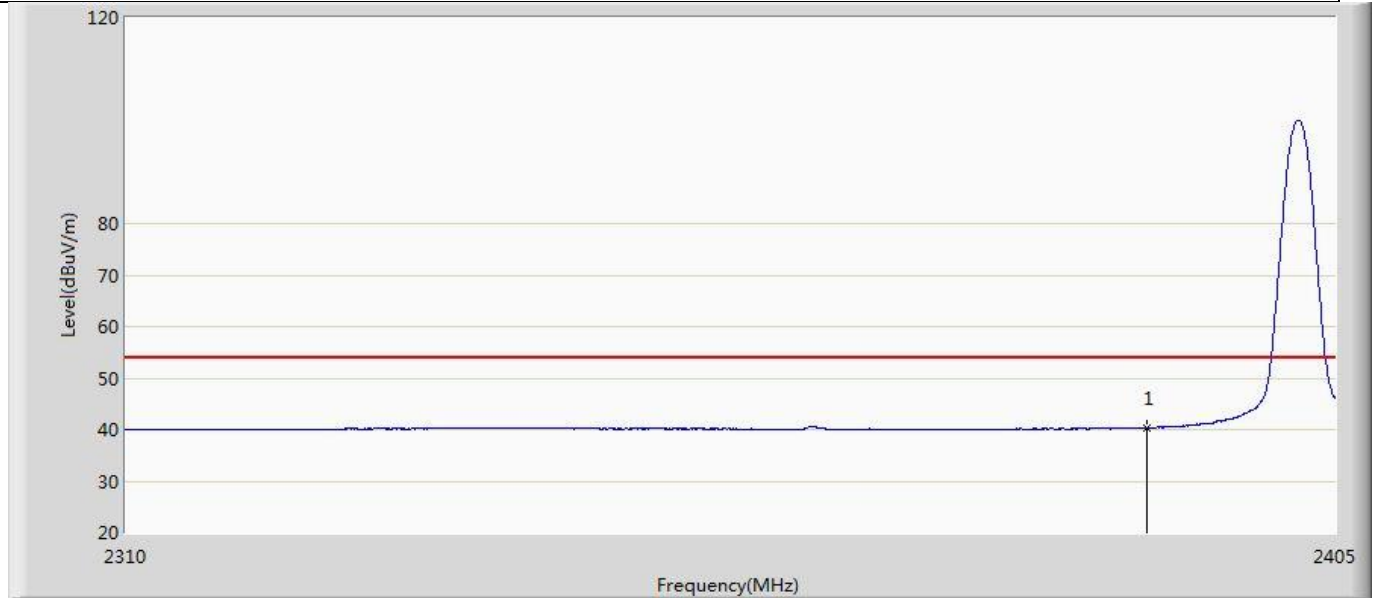

No	Mark	Frequency (MHz)	Measure Level (dBuV/m)	Reading Level (dBuV)	Over Limit (dB)	Limit (dBuV/m)	Factor (dB)	Type
1	*	2390.000	40.344	3.212	-13.656	54.000	37.133	AV

Profile: 2210382R	Page No.: 5
Engineer: YULIU	
Site: AC5	Time: 2022/02/08 - 20:28
Limit: FCC_Part15.209_RE(3m)	Margin: 0
Probe: Horn_3117_00167055(1-18GHz)	Polarity: Vertical
EUT: LED DEVICE	Power: AC 120V/60Hz
Note: Mode 1:Transmit at 2480MHz by BLE_1M	

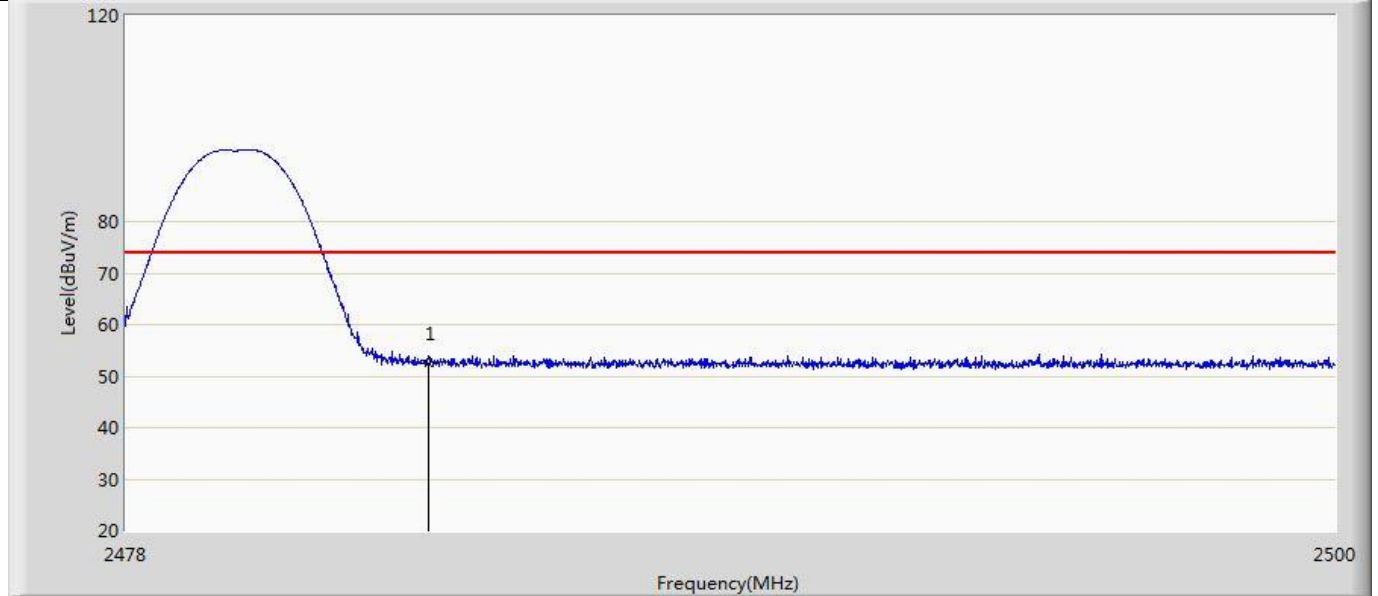

No	Mark	Frequency (MHz)	Measure Level (dBuV/m)	Reading Level (dBuV)	Over Limit (dB)	Limit (dBuV/m)	Factor (dB)	Type
1	*	2483.500	52.471	15.364	-21.529	74.000	37.106	PK

Profile: 2210382R	Page No.: 6
Engineer: YULIU	
Site: AC5	Time: 2022/02/08 - 20:31
Limit: FCC_Part15.209_RE(3m)	Margin: 0
Probe: Horn_3117_00167055(1-18GHz)	Polarity: Vertical
EUT: LED DEVICE	Power: AC 120V/60Hz
Note: Mode 1:Transmit at 2480MHz by BLE_1M	

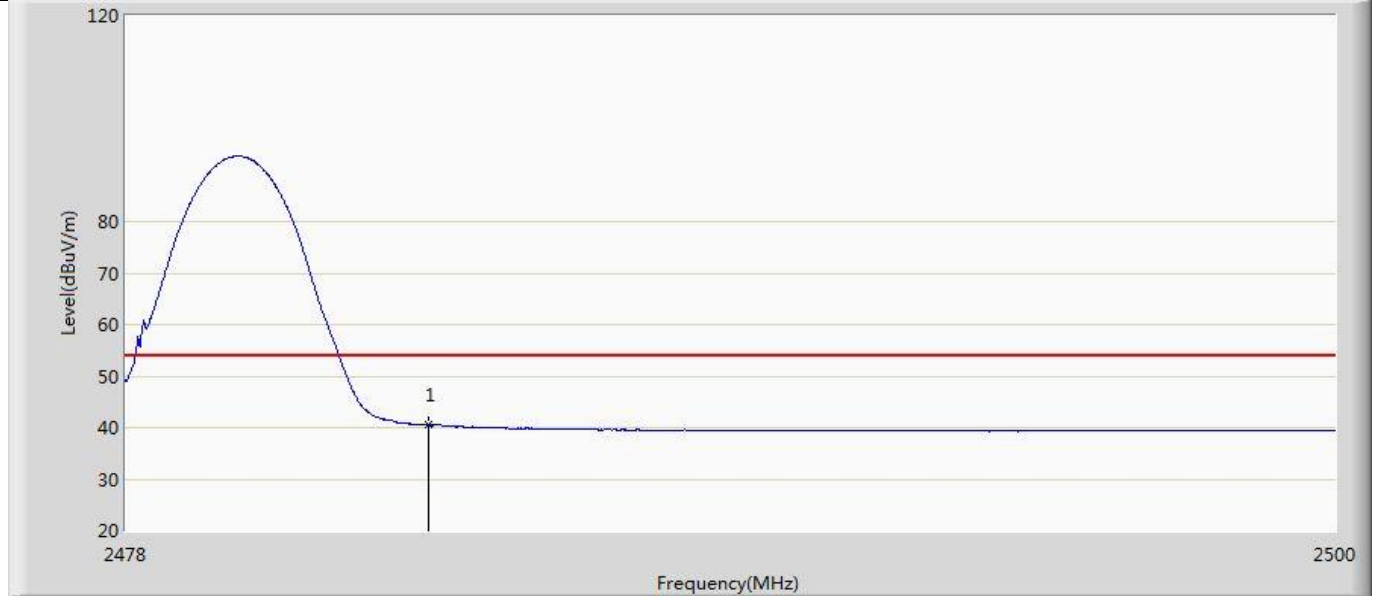

No	Mark	Frequency (MHz)	Measure Level (dBuV/m)	Reading Level (dBuV)	Over Limit (dB)	Limit (dBuV/m)	Factor (dB)	Type
1	*	2483.500	40.516	3.409	-13.484	54.000	37.106	AV



Profile: 2210382R	Page No.: 7
Engineer: YULIU	
Site: AC5	Time: 2022/02/08 - 20:33
Limit: FCC_Part15.209_RE(3m)	Margin: 0
Probe: Horn_3117_00167055(1-18GHz)	Polarity: Horizontal
EUT: LED DEVICE	Power: AC 120V/60Hz
Note: Mode 1:Transmit at 2480MHz by BLE_1M	

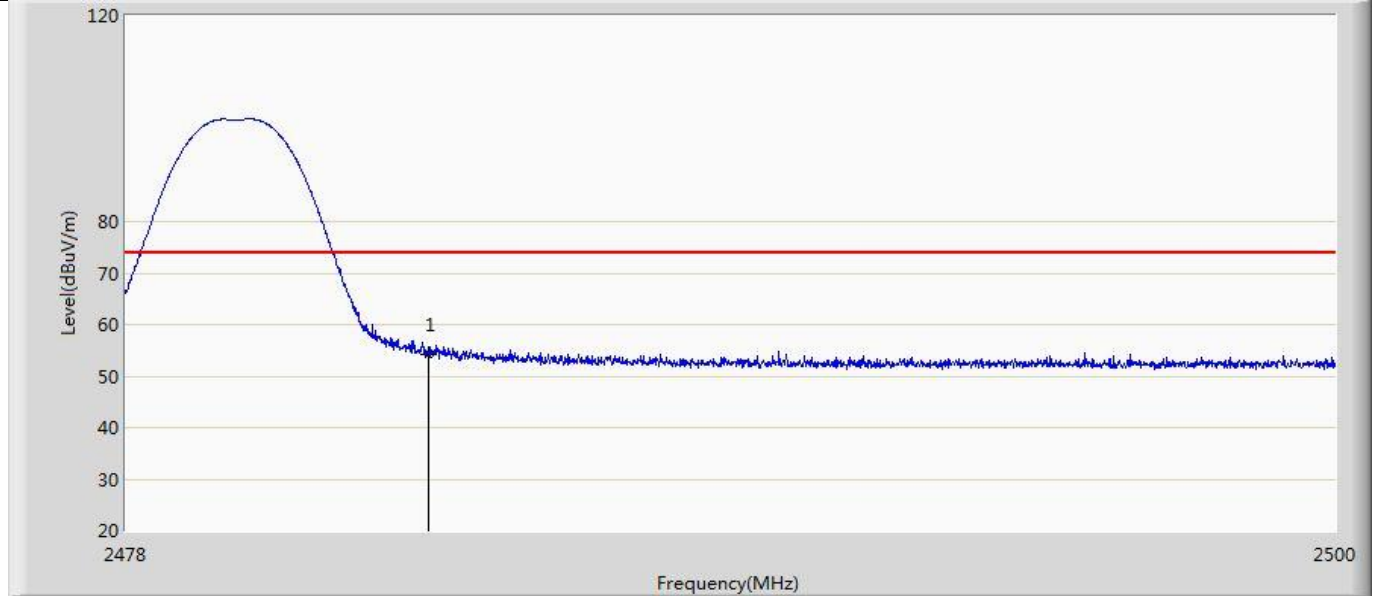

No	Mark	Frequency (MHz)	Measure Level (dBuV/m)	Reading Level (dBuV)	Over Limit (dB)	Limit (dBuV/m)	Factor (dB)	Type
1	*	2483.500	54.147	17.040	-19.853	74.000	37.106	PK

Profile: 2210382R	Page No.: 8
Engineer: YULIU	
Site: AC5	Time: 2022/02/08 - 20:36
Limit: FCC_Part15.209_RE(3m)	Margin: 0
Probe: Horn_3117_00167055(1-18GHz)	Polarity: Horizontal
EUT: LED DEVICE	Power: AC 120V/60Hz
Note: Mode 1:Transmit at 2480MHz by BLE_1M	

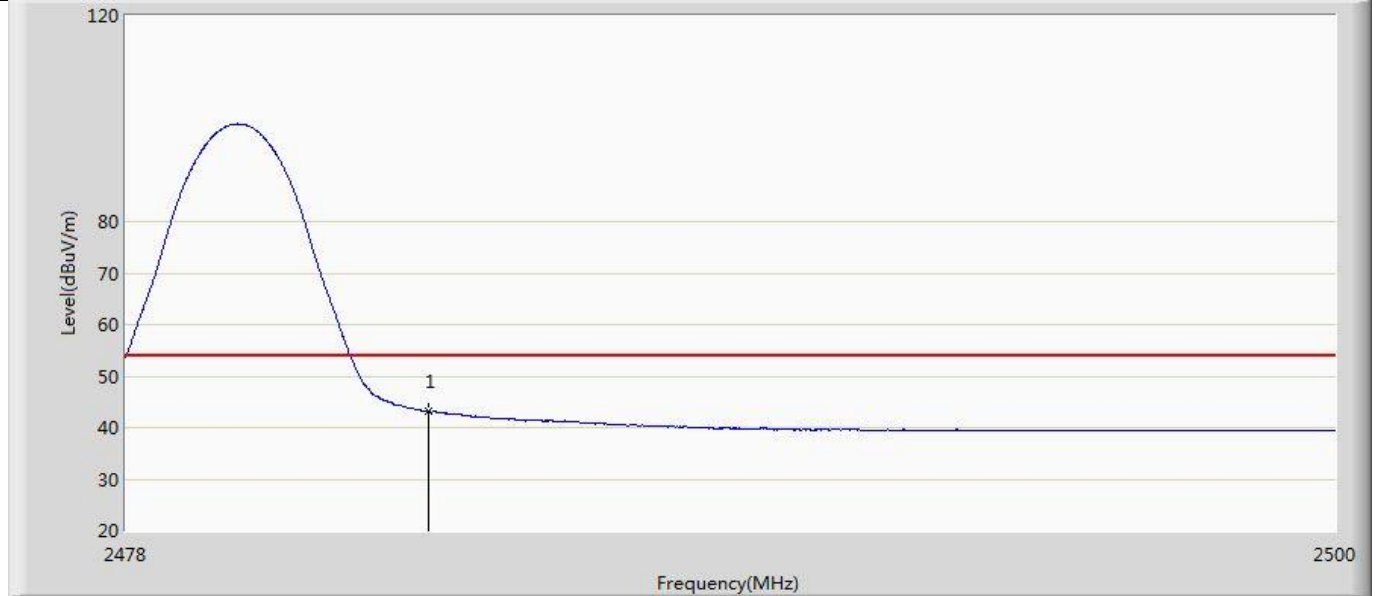

No	Mark	Frequency (MHz)	Measure Level (dBuV/m)	Reading Level (dBuV)	Over Limit (dB)	Limit (dBuV/m)	Factor (dB)	Type
1	*	2483.500	43.146	6.039	-10.854	54.000	37.106	AV

Profile: 2210382R	Page No.: 9
Engineer: YULIU	
Site: AC5	Time: 2022/02/08 - 20:39
Limit: FCC_Part15.209_RE(3m)	Margin: 0
Probe: Horn_3117_00167055(1-18GHz)	Polarity: Vertical
EUT: LED DEVICE	Power: AC 120V/60Hz
Note: Mode 2:Transmit at 2402MHz by BLE_2M	

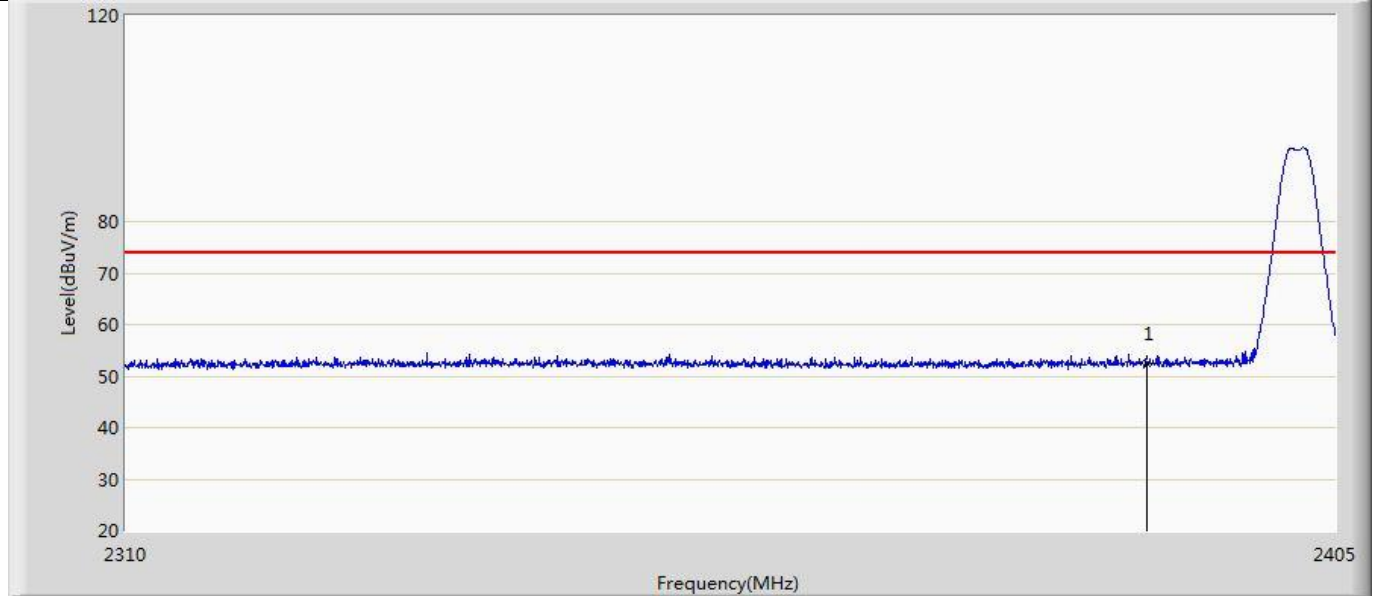

No	Mark	Frequency (MHz)	Measure Level (dBuV/m)	Reading Level (dBuV)	Over Limit (dB)	Limit (dBuV/m)	Factor (dB)	Type
1	*	2390.000	52.513	15.381	-21.487	74.000	37.133	PK

Profile: 2210382R	Page No.: 10
Engineer: YULIU	
Site: AC5	Time: 2022/02/08 - 20:48
Limit: FCC_Part15.209_RE(3m)	Margin: 0
Probe: Horn_3117_00167055(1-18GHz)	Polarity: Vertical
EUT: LED DEVICE	Power: AC 120V/60Hz
Note: Mode 2:Transmit at 2402MHz by BLE_2M	

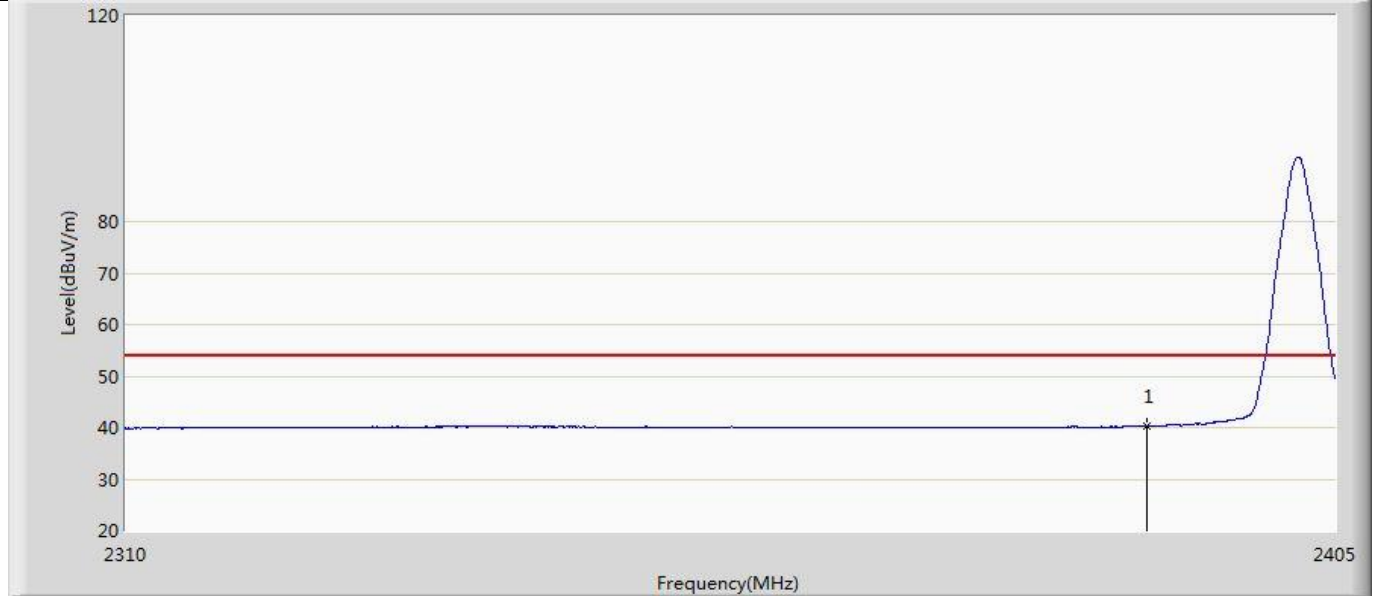

No	Mark	Frequency (MHz)	Measure Level (dBuV/m)	Reading Level (dBuV)	Over Limit (dB)	Limit (dBuV/m)	Factor (dB)	Type
1	*	2390.000	40.265	3.133	-13.735	54.000	37.133	AV

Profile: 2210382R	Page No.: 11
Engineer: YULIU	
Site: AC5	Time: 2022/02/08 - 20:51
Limit: FCC_Part15.209_RE(3m)	Margin: 0
Probe: Horn_3117_00167055(1-18GHz)	Polarity: Horizontal
EUT: LED DEVICE	Power: AC 120V/60Hz
Note: Mode 2:Transmit at 2402MHz by BLE_2M	

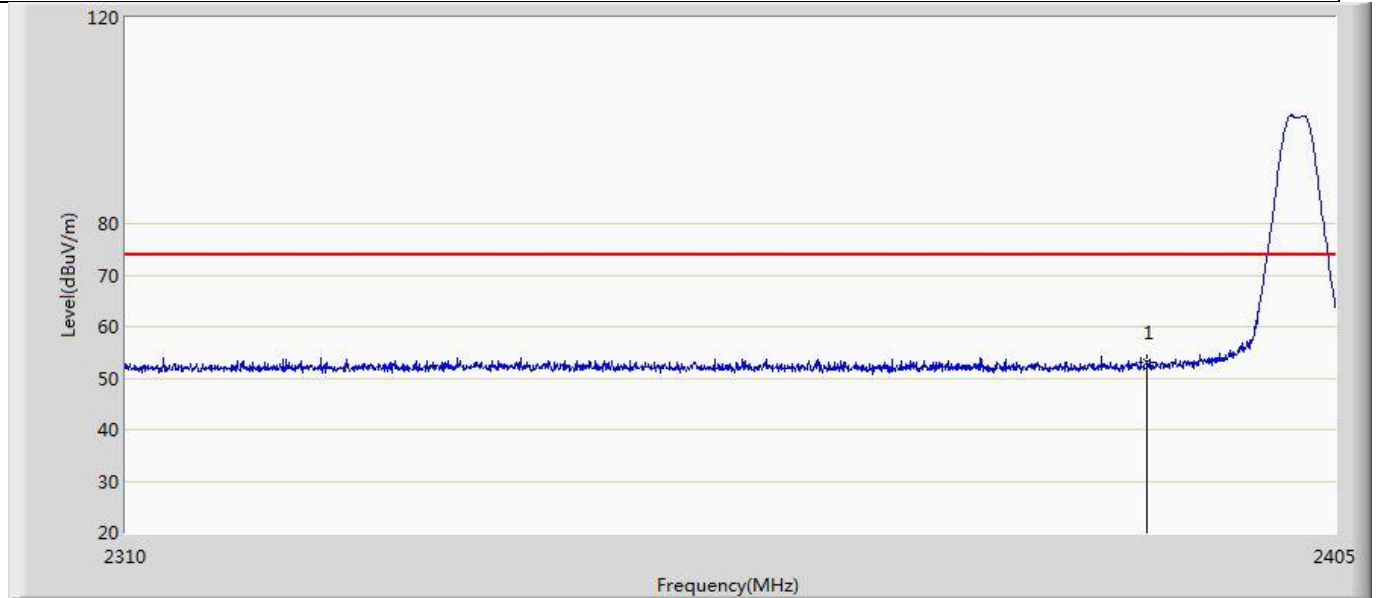

No	Mark	Frequency (MHz)	Measure Level (dBuV/m)	Reading Level (dBuV)	Over Limit (dB)	Limit (dBuV/m)	Factor (dB)	Type
1	*	2390.000	53.147	16.015	-20.853	74.000	37.133	PK

Profile: 2210382R	Page No.: 12
Engineer: YULIU	
Site: AC5	Time: 2022/02/08 - 20:53
Limit: FCC_Part15.209_RE(3m)	Margin: 0
Probe: Horn_3117_00167055(1-18GHz)	Polarity: Horizontal
EUT: LED DEVICE	Power: AC 120V/60Hz
Note: Mode 2:Transmit at 2402MHz by BLE_2M	

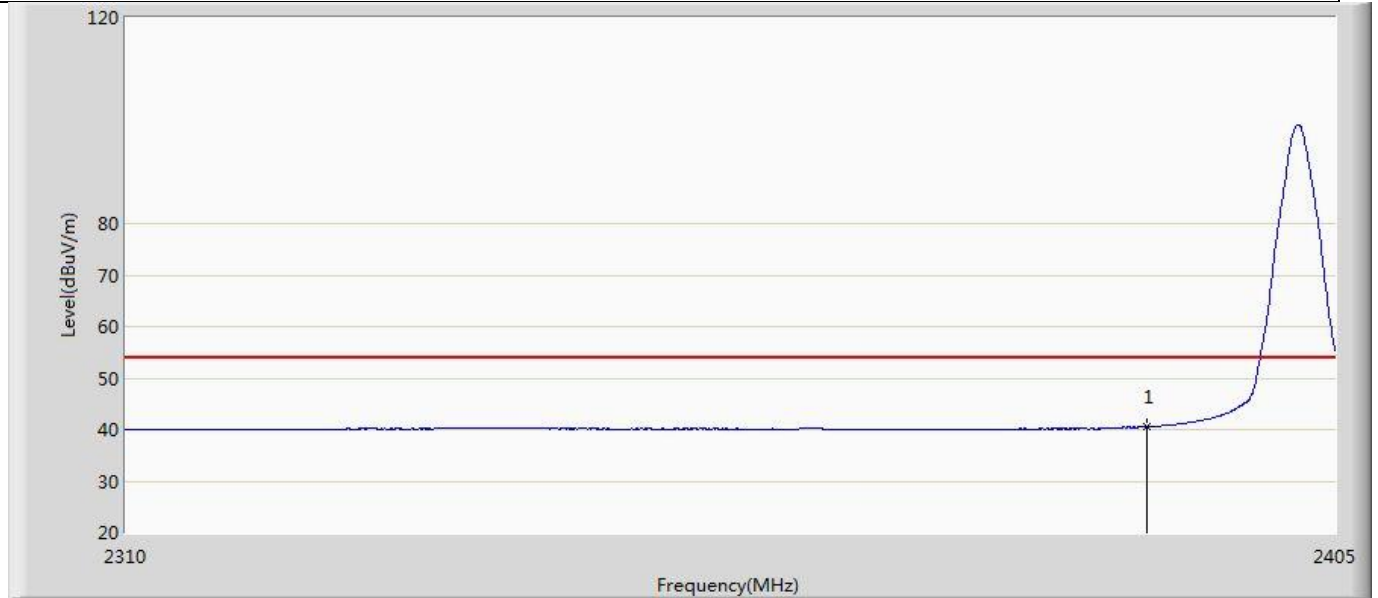

No	Mark	Frequency (MHz)	Measure Level (dBuV/m)	Reading Level (dBuV)	Over Limit (dB)	Limit (dBuV/m)	Factor (dB)	Type
1	*	2390.000	40.520	3.388	-13.480	54.000	37.133	AV

Profile: 2210382R	Page No.: 13
Engineer: YULIU	
Site: AC5	Time: 2022/02/08 - 20:55
Limit: FCC_Part15.209_RE(3m)	Margin: 0
Probe: Horn_3117_00167055(1-18GHz)	Polarity: Vertical
EUT: LED DEVICE	Power: AC 120V/60Hz
Note: Mode 2:Transmit at 2480MHz by BLE_2M	

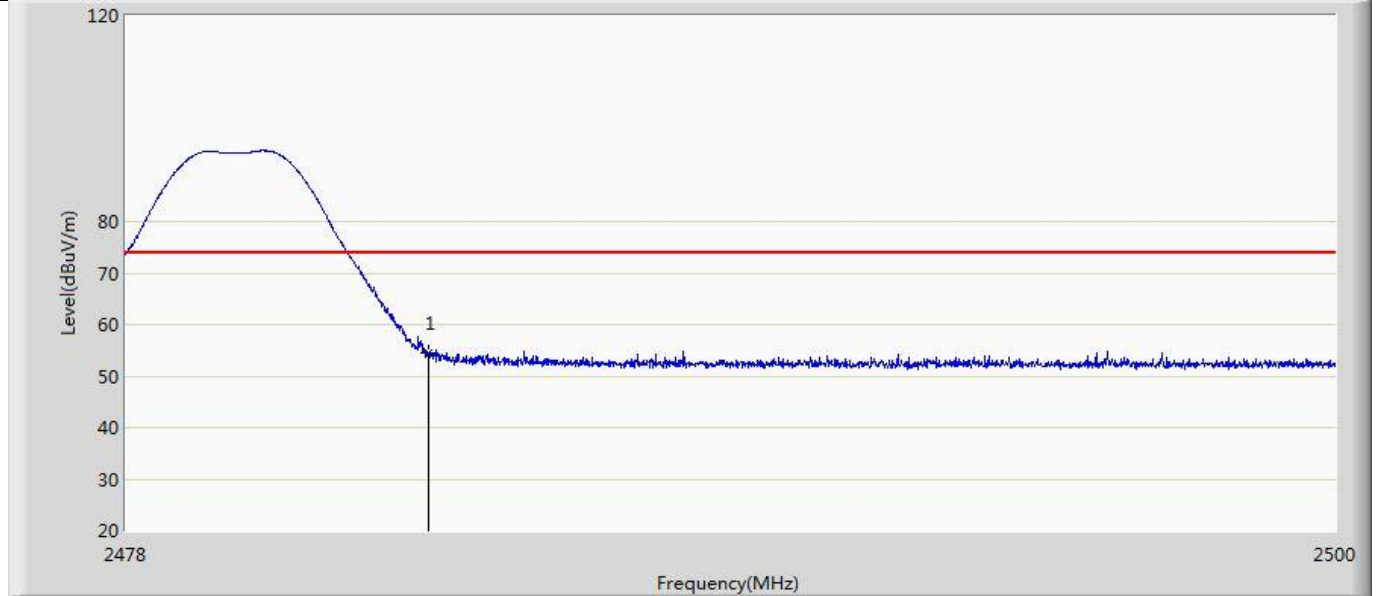

No	Mark	Frequency (MHz)	Measure Level (dBuV/m)	Reading Level (dBuV)	Over Limit (dB)	Limit (dBuV/m)	Factor (dB)	Type
1	*	2483.500	54.526	17.419	-19.474	74.000	37.106	PK

Profile: 2210382R	Page No.: 14
Engineer: YULIU	
Site: AC5	Time: 2022/02/08 - 21:06
Limit: FCC_Part15.209_RE(3m)	Margin: 0
Probe: Horn_3117_00167055(1-18GHz)	Polarity: Vertical
EUT: LED DEVICE	Power: AC 120V/60Hz
Note: Mode 2:Transmit at 2480MHz by BLE_2M	

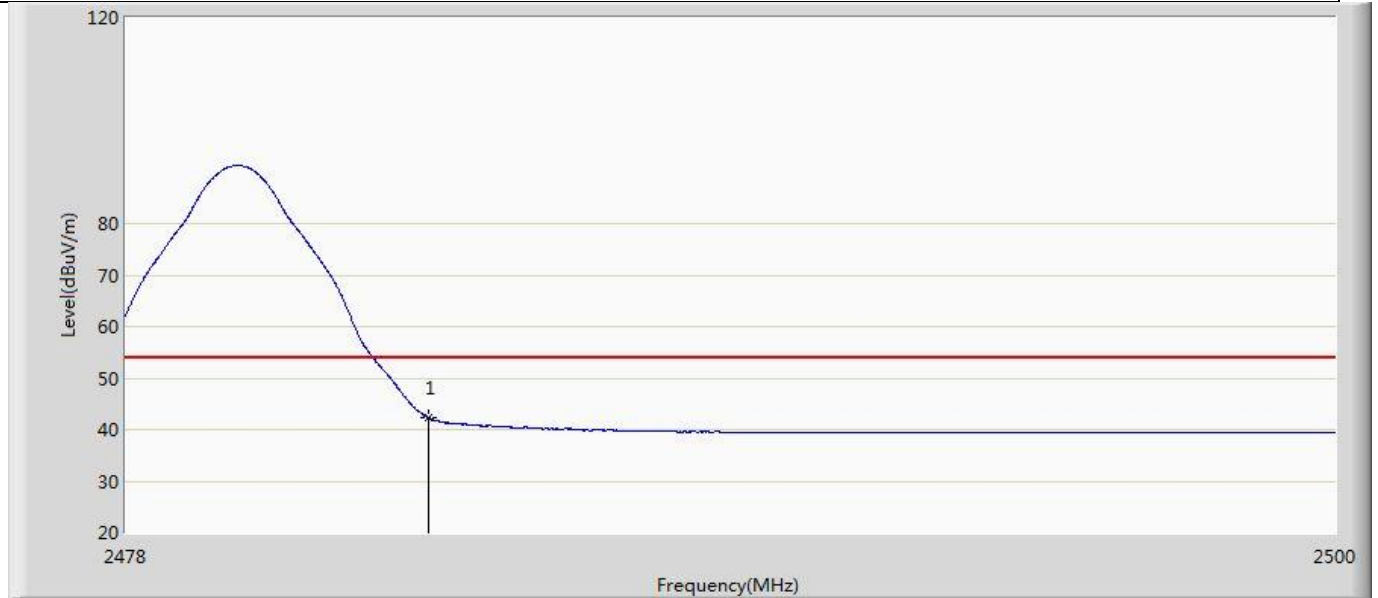

No	Mark	Frequency (MHz)	Measure Level (dBuV/m)	Reading Level (dBuV)	Over Limit (dB)	Limit (dBuV/m)	Factor (dB)	Type
1	*	2483.500	42.248	5.141	-11.752	54.000	37.106	AV



Profile: 2210382R	Page No.: 15
Engineer: YULIU	
Site: AC5	Time: 2022/02/08 - 21:09
Limit: FCC_Part15.209_RE(3m)	Margin: 0
Probe: Horn_3117_00167055(1-18GHz)	Polarity: Horizontal
EUT: LED DEVICE	Power: AC 120V/60Hz
Note: Mode 2:Transmit at 2480MHz by BLE_2M	

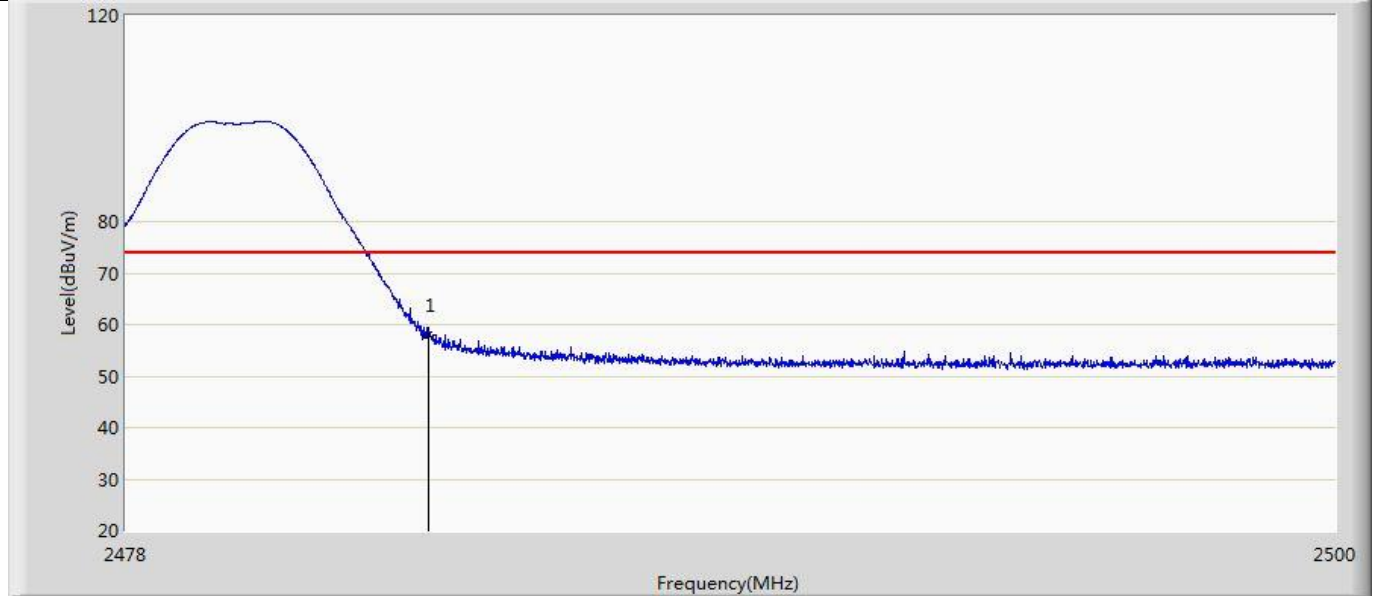

No	Mark	Frequency (MHz)	Measure Level (dBuV/m)	Reading Level (dBuV)	Over Limit (dB)	Limit (dBuV/m)	Factor (dB)	Type
1	*	2483.500	57.886	20.779	-16.114	74.000	37.106	PK

Profile: 2210382R	Page No.: 16
Engineer: YULIU	
Site: AC5	Time: 2022/02/08 - 21:13
Limit: FCC_Part15.209_RE(3m)	Margin: 0
Probe: Horn_3117_00167055(1-18GHz)	Polarity: Horizontal
EUT: LED DEVICE	Power: AC 120V/60Hz
Note: Mode 2:Transmit at 2480MHz by BLE_2M	

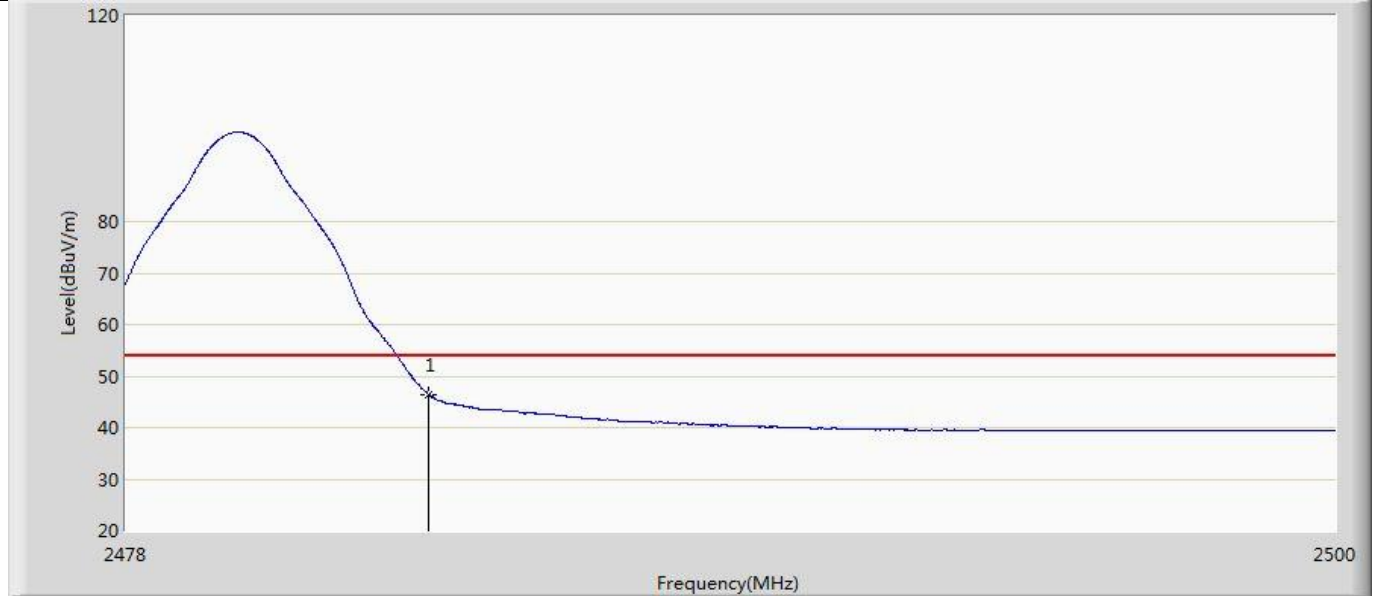

No	Mark	Frequency (MHz)	Measure Level (dBuV/m)	Reading Level (dBuV)	Over Limit (dB)	Limit (dBuV/m)	Factor (dB)	Type
1	*	2483.500	46.402	9.295	-7.598	54.000	37.106	AV

Profile: 2210382R	Page No.: 17
Engineer: YULIU	
Site: AC5	Time: 2022/02/08 - 21:16
Limit: FCC_Part15.209_RE(3m)	Margin: 0
Probe: Horn_3117_00167055(1-18GHz)	Polarity: Vertical
EUT: LED DEVICE	Power: AC 120V/60Hz
Note: Mode 3:Transmit at 2402MHz by Code2	

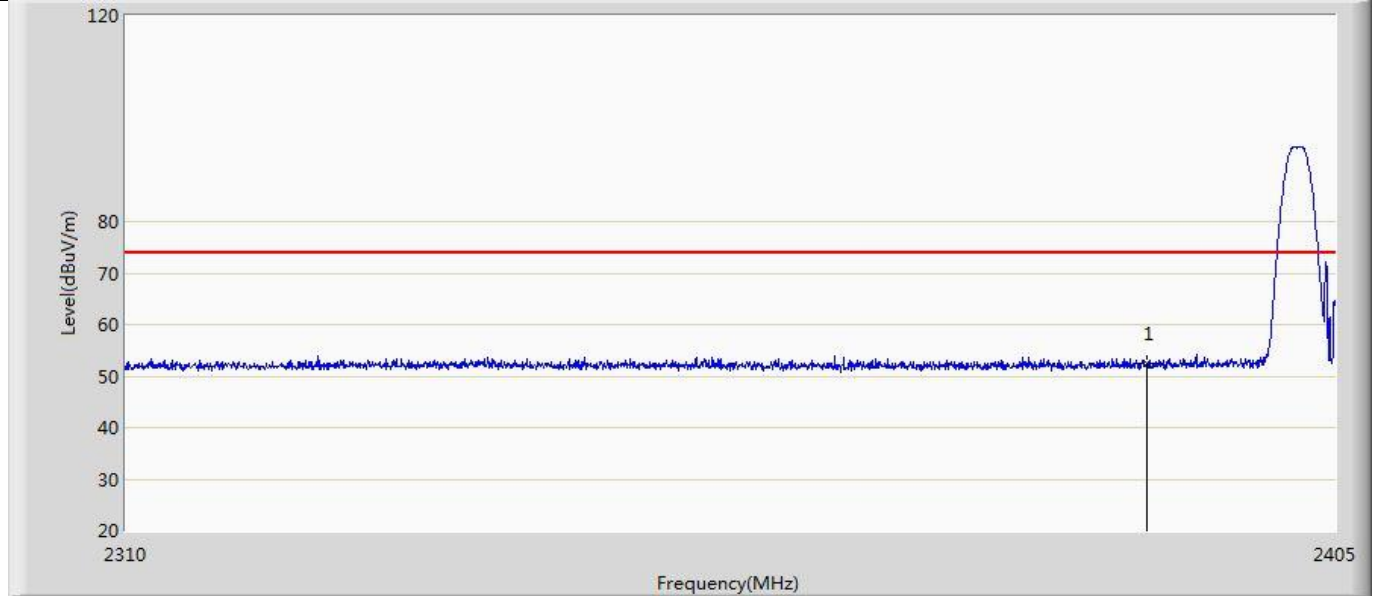

No	Mark	Frequency (MHz)	Measure Level (dBuV/m)	Reading Level (dBuV)	Over Limit (dB)	Limit (dBuV/m)	Factor (dB)	Type
1	*	2390.000	52.484	15.352	-21.516	74.000	37.133	PK

Profile: 2210382R	Page No.: 18
Engineer: YULIU	
Site: AC5	Time: 2022/02/08 - 21:20
Limit: FCC_Part15.209_RE(3m)	Margin: 0
Probe: Horn_3117_00167055(1-18GHz)	Polarity: Vertical
EUT: LED DEVICE	Power: AC 120V/60Hz
Note: Mode 3:Transmit at 2402MHz by Code2	

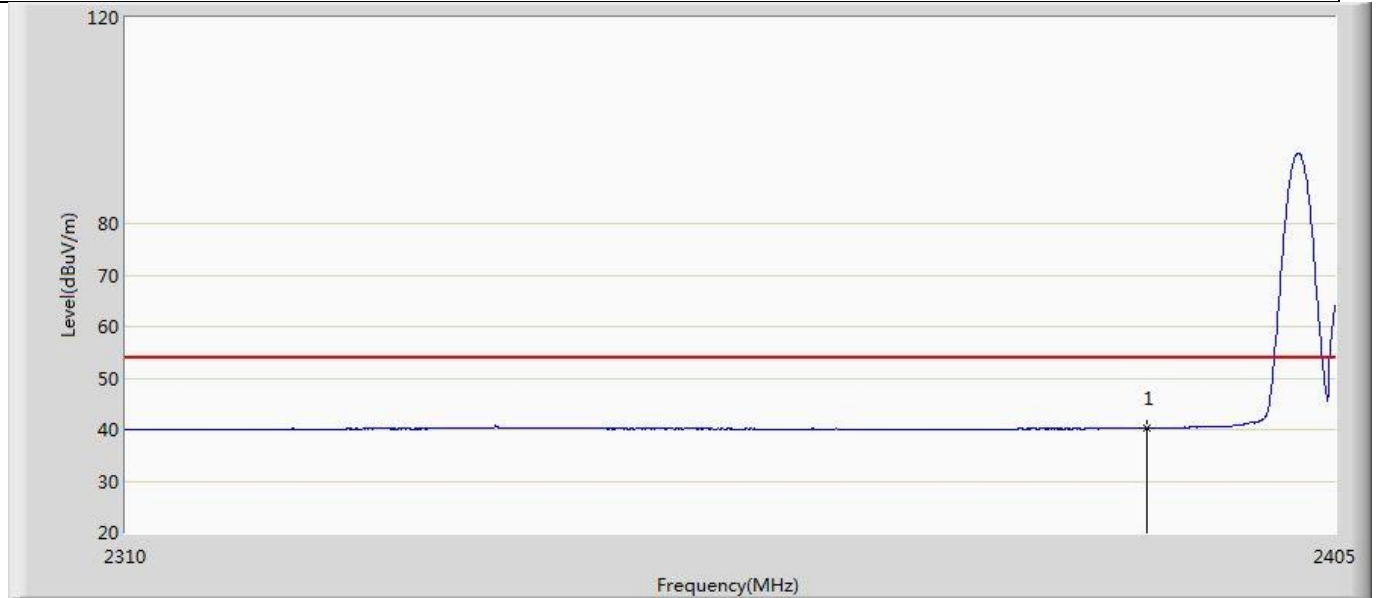

No	Mark	Frequency (MHz)	Measure Level (dBuV/m)	Reading Level (dBuV)	Over Limit (dB)	Limit (dBuV/m)	Factor (dB)	Type
1	*	2390.000	40.276	3.144	-13.724	54.000	37.133	AV

Profile: 2210382R	Page No.: 19
Engineer: YULIU	
Site: AC5	Time: 2022/02/08 - 21:22
Limit: FCC_Part15.209_RE(3m)	Margin: 0
Probe: Horn_3117_00167055(1-18GHz)	Polarity: Horizontal
EUT: LED DEVICE	Power: AC 120V/60Hz
Note: Mode 3:Transmit at 2402MHz by Code2	

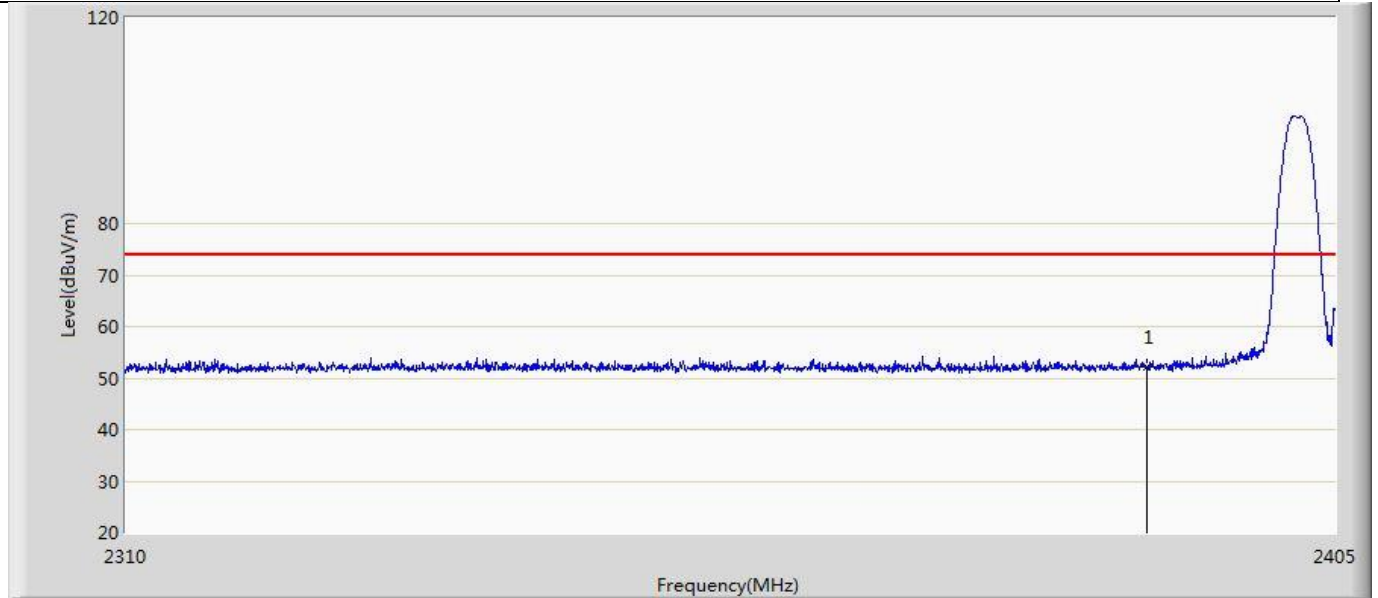

No	Mark	Frequency (MHz)	Measure Level (dBuV/m)	Reading Level (dBuV)	Over Limit (dB)	Limit (dBuV/m)	Factor (dB)	Type
1	*	2390.000	52.175	15.043	-21.825	74.000	37.133	PK

Profile: 2210382R	Page No.: 20
Engineer: YULIU	
Site: AC5	Time: 2022/02/08 - 21:24
Limit: FCC_Part15.209_RE(3m)	Margin: 0
Probe: Horn_3117_00167055(1-18GHz)	Polarity: Horizontal
EUT: LED DEVICE	Power: AC 120V/60Hz
Note: Mode 3:Transmit at 2402MHz by Code2	

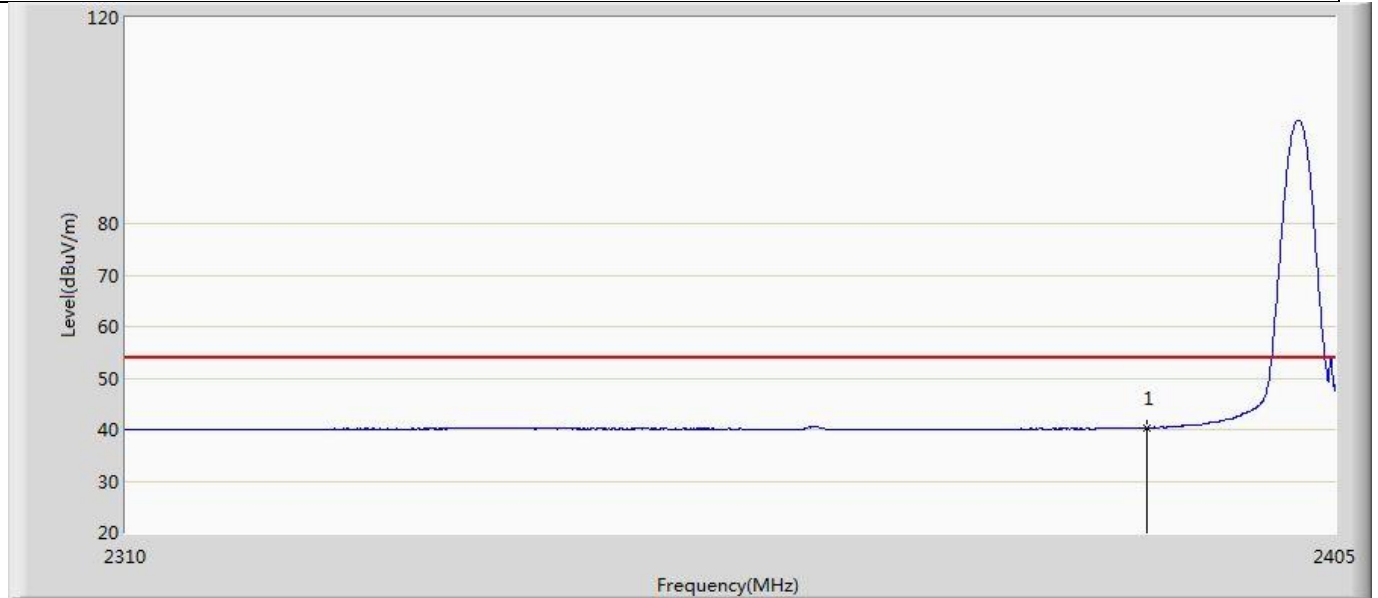

No	Mark	Frequency (MHz)	Measure Level (dBuV/m)	Reading Level (dBuV)	Over Limit (dB)	Limit (dBuV/m)	Factor (dB)	Type
1	*	2390.000	40.278	3.146	-13.722	54.000	37.133	AV

Profile: 2210382R	Page No.: 21
Engineer: YULIU	
Site: AC5	Time: 2022/02/08 - 21:26
Limit: FCC_Part15.209_RE(3m)	Margin: 0
Probe: Horn_3117_00167055(1-18GHz)	Polarity: Vertical
EUT: LED DEVICE	Power: AC 120V/60Hz
Note: Mode 3:Transmit at 2480MHz by Code2	

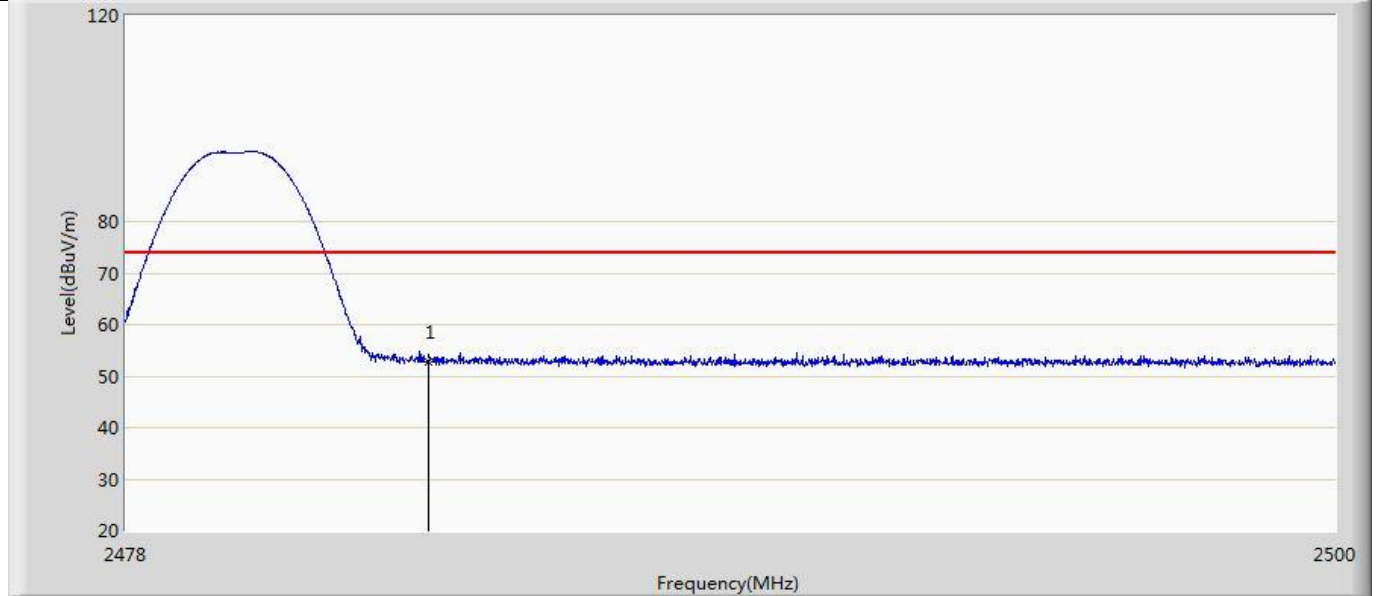

No	Mark	Frequency (MHz)	Measure Level (dBuV/m)	Reading Level (dBuV)	Over Limit (dB)	Limit (dBuV/m)	Factor (dB)	Type
1	*	2483.500	52.888	15.781	-21.112	74.000	37.106	PK

Profile: 2210382R	Page No.: 22
Engineer: YULIU	
Site: AC5	Time: 2022/02/08 - 21:29
Limit: FCC_Part15.209_RE(3m)	Margin: 0
Probe: Horn_3117_00167055(1-18GHz)	Polarity: Vertical
EUT: LED DEVICE	Power: AC 120V/60Hz
Note: Mode 3:Transmit at 2480MHz by Code2	

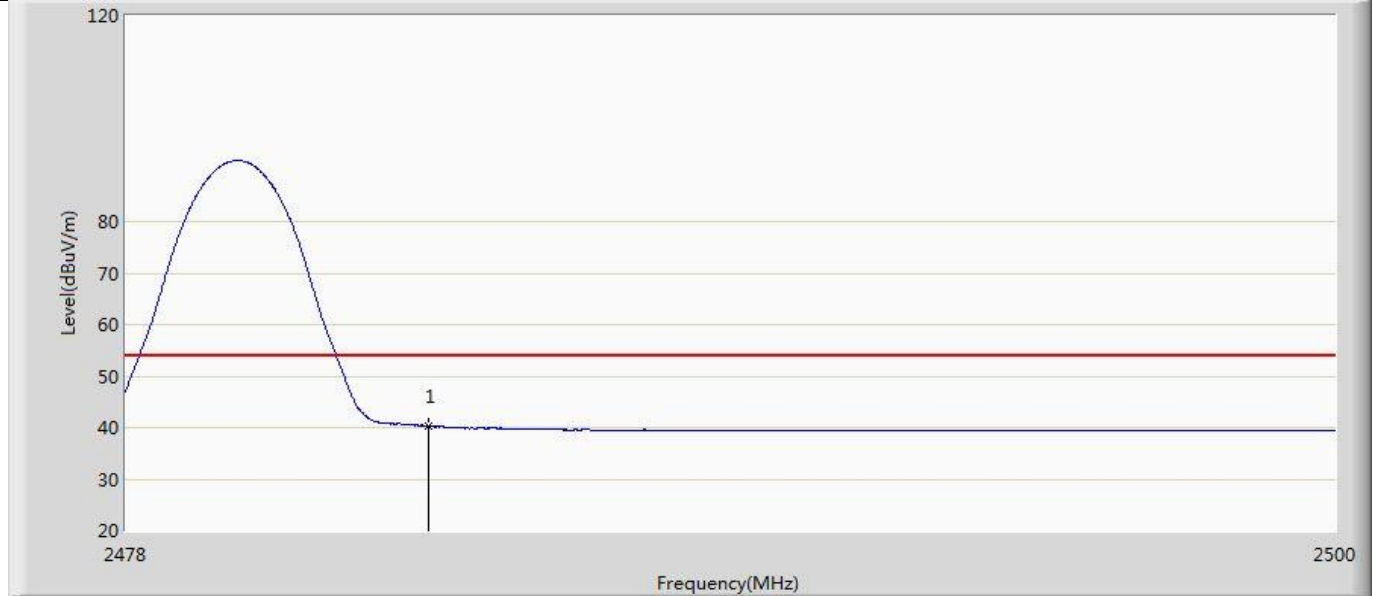

No	Mark	Frequency (MHz)	Measure Level (dBuV/m)	Reading Level (dBuV)	Over Limit (dB)	Limit (dBuV/m)	Factor (dB)	Type
1	*	2483.500	40.380	3.273	-13.620	54.000	37.106	AV



Profile: 2210382R	Page No.: 23
Engineer: YULIU	
Site: AC5	Time: 2022/02/08 - 21:31
Limit: FCC_Part15.209_RE(3m)	Margin: 0
Probe: Horn_3117_00167055(1-18GHz)	Polarity: Horizontal
EUT: LED DEVICE	Power: AC 120V/60Hz
Note: Mode 3:Transmit at 2480MHz by Code2	

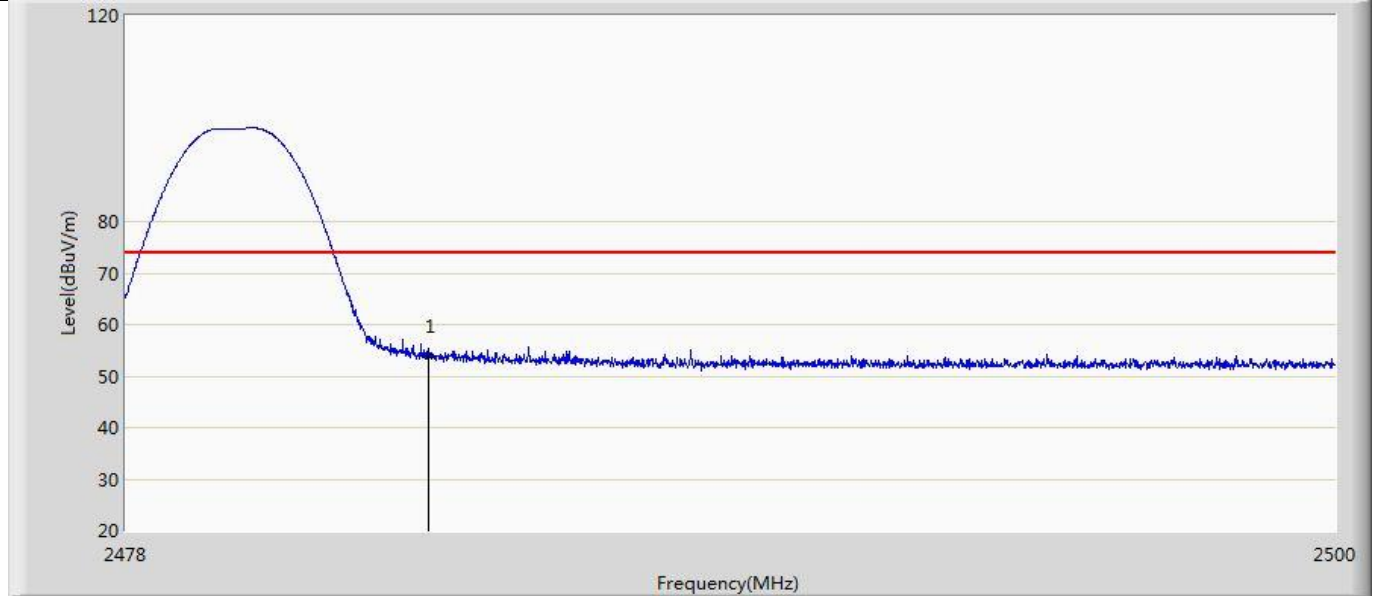

No	Mark	Frequency (MHz)	Measure Level (dBuV/m)	Reading Level (dBuV)	Over Limit (dB)	Limit (dBuV/m)	Factor (dB)	Type
1	*	2483.500	53.972	16.865	-20.028	74.000	37.106	PK

Profile: 2210382R	Page No.: 24
Engineer: YULIU	
Site: AC5	Time: 2022/02/08 - 21:34
Limit: FCC_Part15.209_RE(3m)	Margin: 0
Probe: Horn_3117_00167055(1-18GHz)	Polarity: Horizontal
EUT: LED DEVICE	Power: AC 120V/60Hz
Note: Mode 3:Transmit at 2480MHz by Code2	

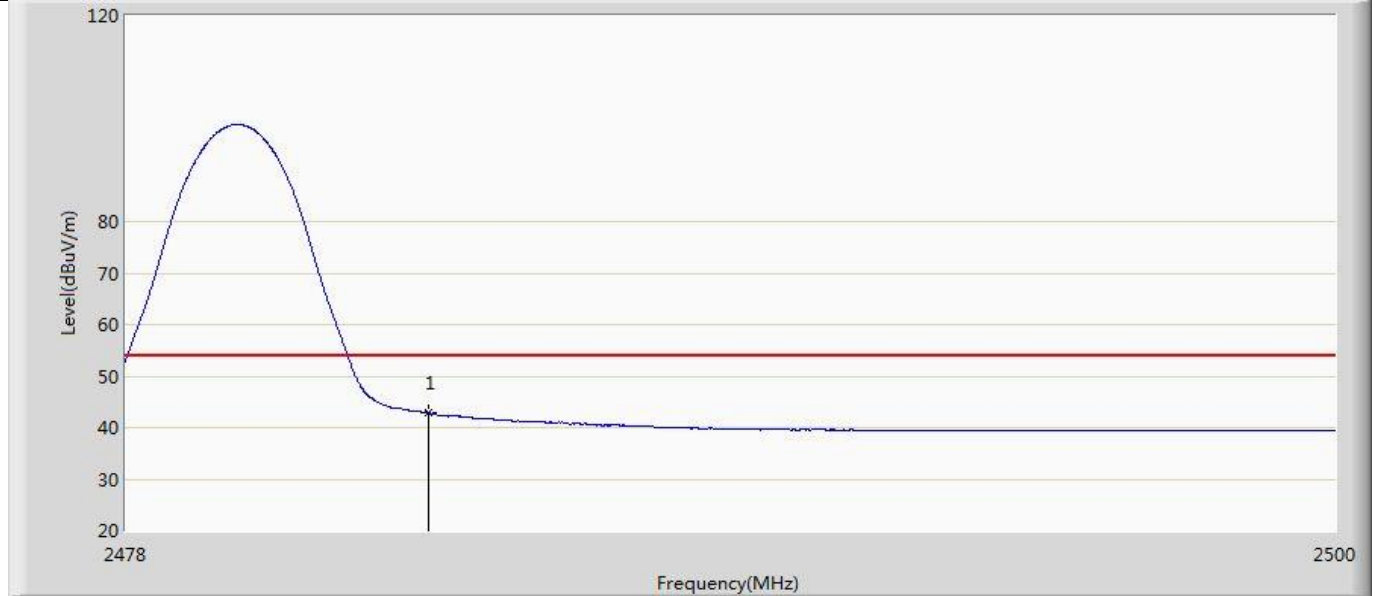

No	Mark	Frequency (MHz)	Measure Level (dBuV/m)	Reading Level (dBuV)	Over Limit (dB)	Limit (dBuV/m)	Factor (dB)	Type
1	*	2483.500	42.885	5.778	-11.115	54.000	37.106	AV

Profile: 2210382R	Page No.: 25
Engineer: YULIU	
Site: AC5	Time: 2022/02/08 - 21:36
Limit: FCC_Part15.209_RE(3m)	Margin: 0
Probe: Horn_3117_00167055(1-18GHz)	Polarity: Vertical
EUT: LED DEVICE	Power: AC 120V/60Hz
Note: Mode 4:Transmit at 2402MHz by Code8	

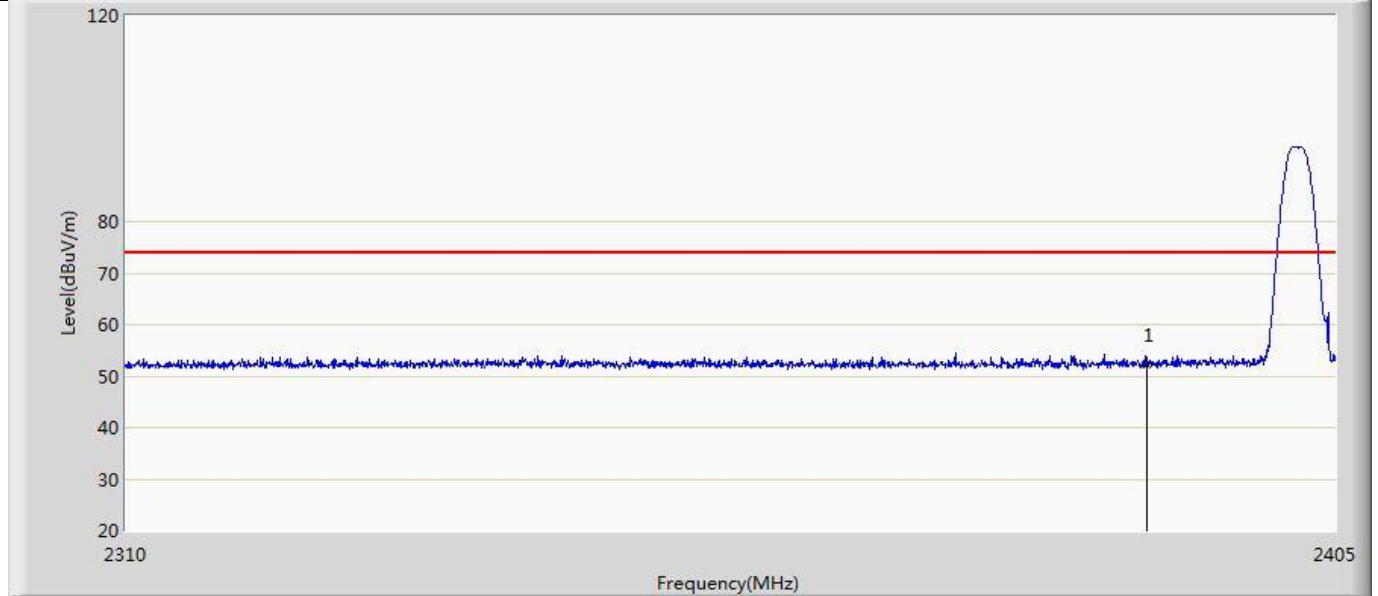

No	Mark	Frequency (MHz)	Measure Level (dBuV/m)	Reading Level (dBuV)	Over Limit (dB)	Limit (dBuV/m)	Factor (dB)	Type
1	*	2390.000	52.215	15.083	-21.785	74.000	37.133	PK

Profile: 2210382R	Page No.: 26
Engineer: YULIU	
Site: AC5	Time: 2022/02/08 - 21:39
Limit: FCC_Part15.209_RE(3m)	Margin: 0
Probe: Horn_3117_00167055(1-18GHz)	Polarity: Vertical
EUT: LED DEVICE	Power: AC 120V/60Hz
Note: Mode 4:Transmit at 2402MHz by Code8	



No	Mark	Frequency (MHz)	Measure Level (dBuV/m)	Reading Level (dBuV)	Over Limit (dB)	Limit (dBuV/m)	Factor (dB)	Type
1	*	2390.000	40.284	3.152	-13.716	54.000	37.133	AV

Profile: 2210382R	Page No.: 27
Engineer: YULIU	
Site: AC5	Time: 2022/02/08 - 21:42
Limit: FCC_Part15.209_RE(3m)	Margin: 0
Probe: Horn_3117_00167055(1-18GHz)	Polarity: Horizontal
EUT: LED DEVICE	Power: AC 120V/60Hz
Note: Mode 4:Transmit at 2402MHz by Code8	

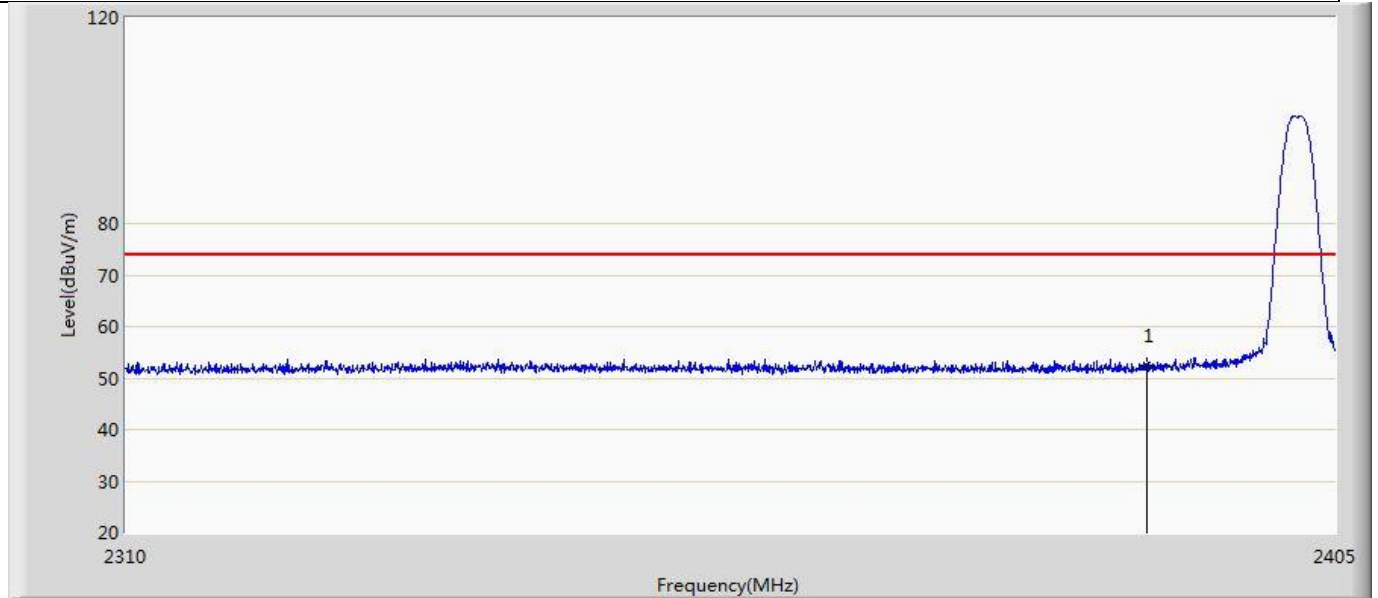

No	Mark	Frequency (MHz)	Measure Level (dBuV/m)	Reading Level (dBuV)	Over Limit (dB)	Limit (dBuV/m)	Factor (dB)	Type
1	*	2390.000	52.433	15.301	-21.567	74.000	37.133	PK

Profile: 2210382R	Page No.: 28
Engineer: YULIU	
Site: AC5	Time: 2022/02/08 - 21:44
Limit: FCC_Part15.209_RE(3m)	Margin: 0
Probe: Horn_3117_00167055(1-18GHz)	Polarity: Horizontal
EUT: LED DEVICE	Power: AC 120V/60Hz
Note: Mode 4:Transmit at 2402MHz by Code8	

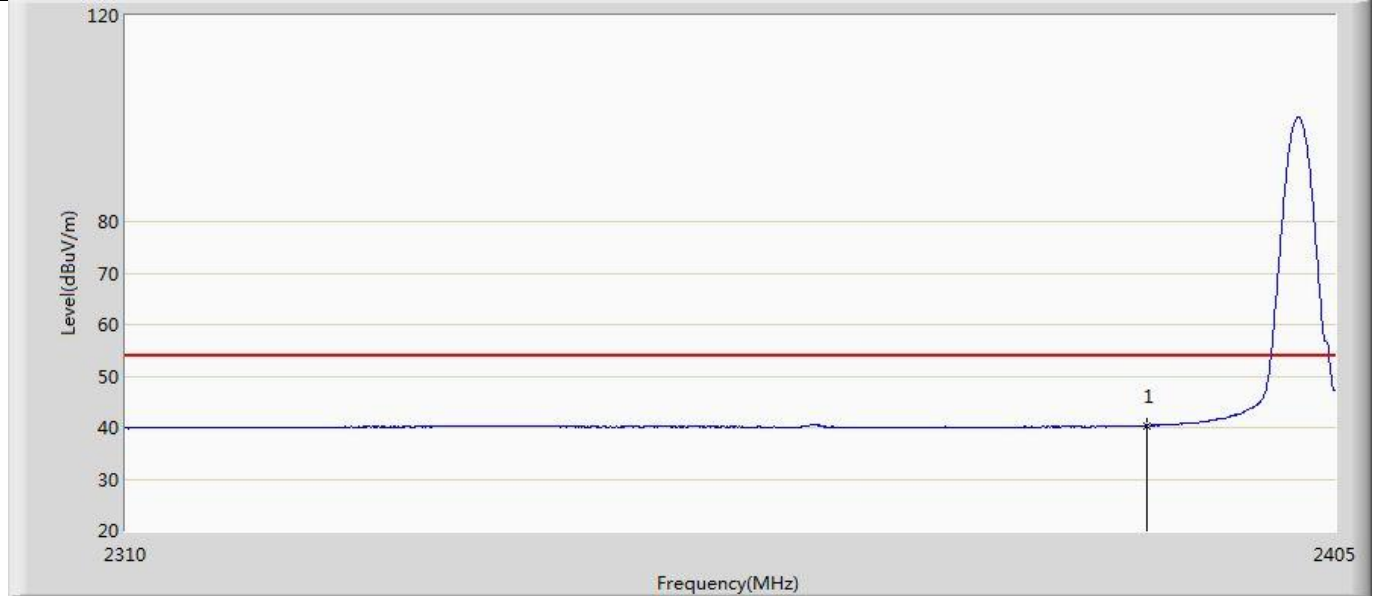

No	Mark	Frequency (MHz)	Measure Level (dBuV/m)	Reading Level (dBuV)	Over Limit (dB)	Limit (dBuV/m)	Factor (dB)	Type
1	*	2390.000	40.415	3.283	-13.585	54.000	37.133	AV

Profile: 2210382R	Page No.: 29
Engineer: YULIU	
Site: AC5	Time: 2022/02/08 - 21:46
Limit: FCC_Part15.209_RE(3m)	Margin: 0
Probe: Horn_3117_00167055(1-18GHz)	Polarity: Vertical
EUT: LED DEVICE	Power: AC 120V/60Hz
Note: Mode 4:Transmit at 2480MHz by Code8	

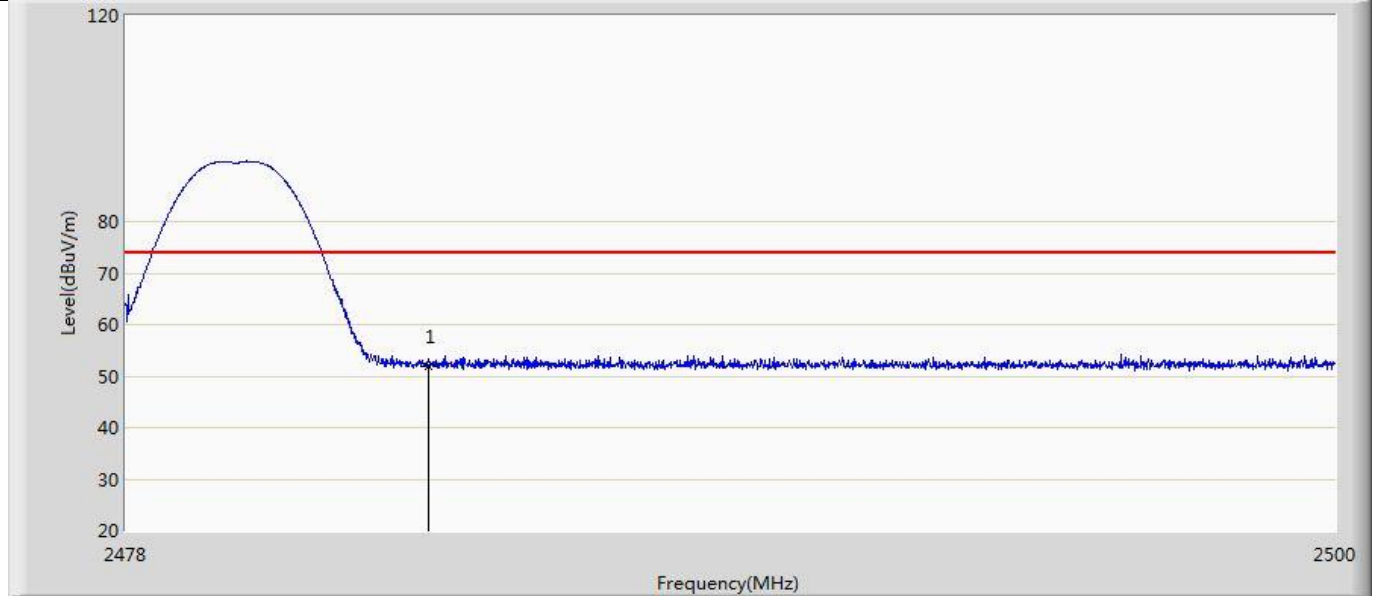

No	Mark	Frequency (MHz)	Measure Level (dBuV/m)	Reading Level (dBuV)	Over Limit (dB)	Limit (dBuV/m)	Factor (dB)	Type
1	*	2483.500	51.876	14.769	-22.124	74.000	37.106	PK

Profile: 2210382R	Page No.: 30
Engineer: YULIU	
Site: AC5	Time: 2022/02/08 - 21:51
Limit: FCC_Part15.209_RE(3m)	Margin: 0
Probe: Horn_3117_00167055(1-18GHz)	Polarity: Vertical
EUT: LED DEVICE	Power: AC 120V/60Hz
Note: Mode 4:Transmit at 2480MHz by Code8	

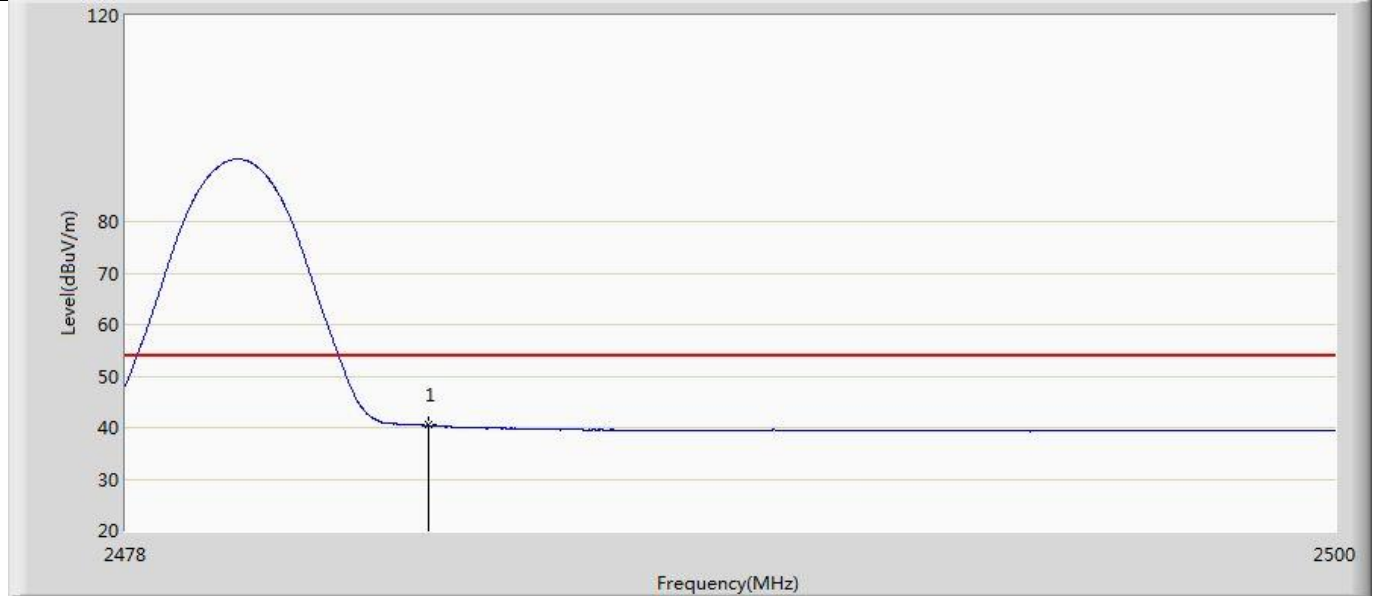

No	Mark	Frequency (MHz)	Measure Level (dBuV/m)	Reading Level (dBuV)	Over Limit (dB)	Limit (dBuV/m)	Factor (dB)	Type
1	*	2483.500	40.436	3.329	-13.564	54.000	37.106	AV



Profile: 2210382R	Page No.: 31
Engineer: YULIU	
Site: AC5	Time: 2022/02/08 - 21:54
Limit: FCC_Part15.209_RE(3m)	Margin: 0
Probe: Horn_3117_00167055(1-18GHz)	Polarity: Horizontal
EUT: LED DEVICE	Power: AC 120V/60Hz
Note: Mode 4:Transmit at 2480MHz by Code8	

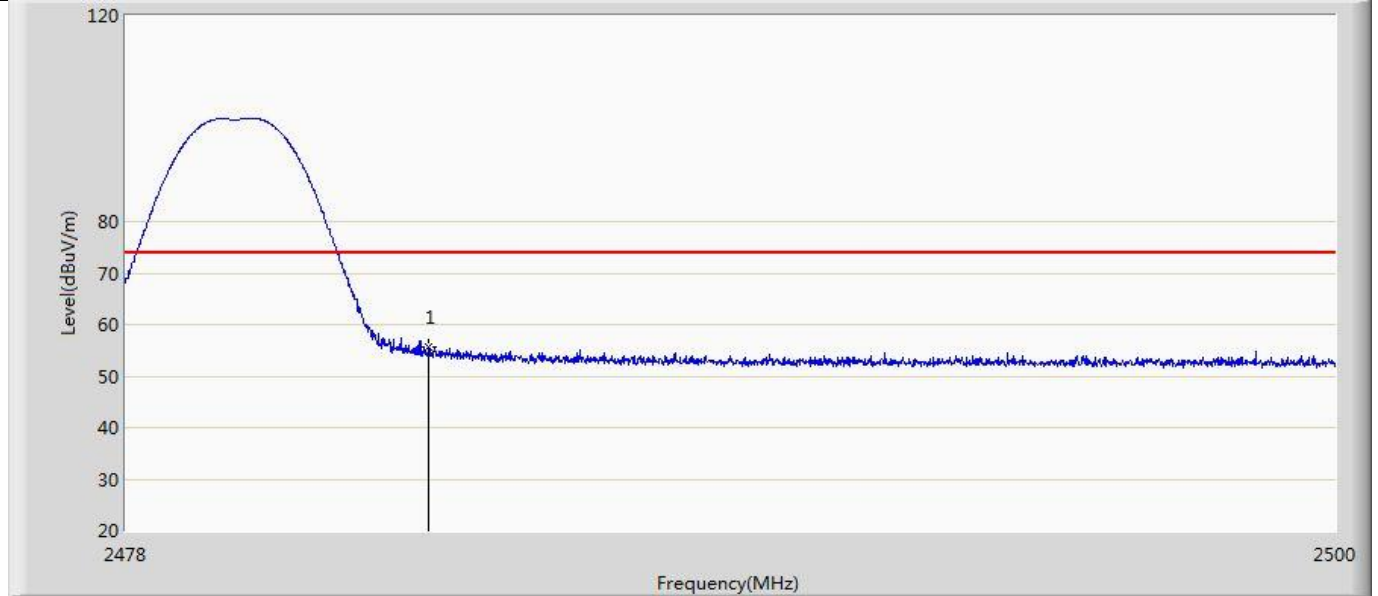

No	Mark	Frequency (MHz)	Measure Level (dBuV/m)	Reading Level (dBuV)	Over Limit (dB)	Limit (dBuV/m)	Factor (dB)	Type
1	*	2483.500	55.766	18.659	-18.234	74.000	37.106	PK

Profile: 2210382R	Page No.: 32
Engineer: YULIU	
Site: AC5	Time: 2022/02/08 - 21:56
Limit: FCC_Part15.209_RE(3m)	Margin: 0
Probe: Horn_3117_00167055(1-18GHz)	Polarity: Horizontal
EUT: LED DEVICE	Power: AC 120V/60Hz
Note: Mode 4:Transmit at 2480MHz by Code8	

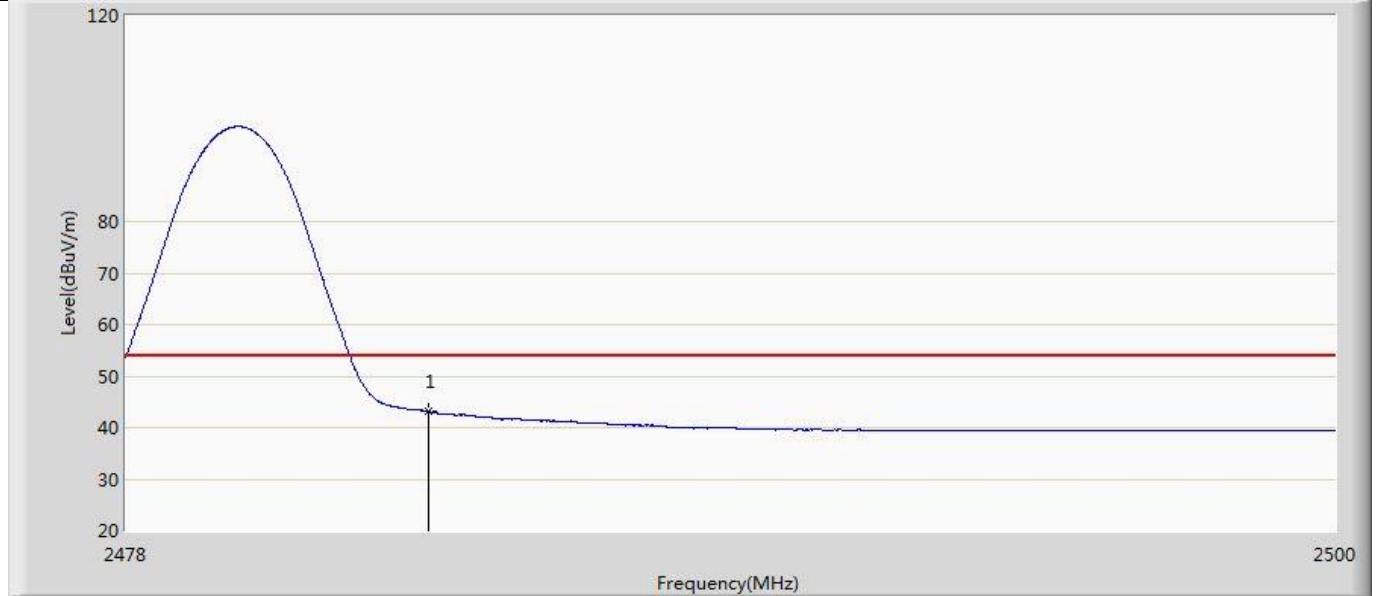

No	Mark	Frequency (MHz)	Measure Level (dBuV/m)	Reading Level (dBuV)	Over Limit (dB)	Limit (dBuV/m)	Factor (dB)	Type
1	*	2483.500	43.148	6.041	-10.852	54.000	37.106	AV

<b>4.6 DTS Bandwidth</b>	<b>VERDICT: PASS</b>
--------------------------	----------------------

<b>4.6.1 Limit</b>	
<b>Standard</b>	FCC Part 15 Subpart C Paragraph 15.247 (a)(2)
Systems using digital modulation techniques operate in the 2400-2483.5 MHz. The minimum 6 dB bandwidth shall be at least 500 kHz	

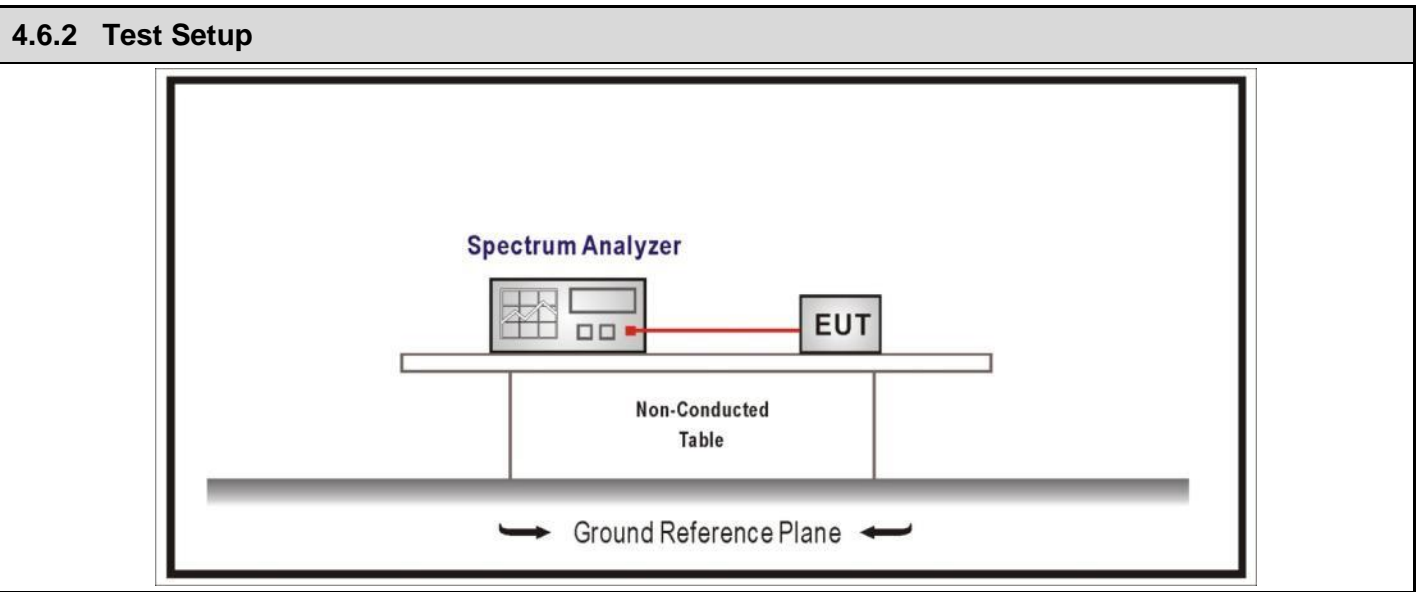

<b>4.6.3 Test Procedure</b>			
	Reference Rule	Chapter	Description
<input checked="" type="checkbox"/>	ANSI C63.10	11.8	DTS bandwidth
<input type="checkbox"/>	ANSI C63.10	11.8.1	Option 1
<input checked="" type="checkbox"/>	ANSI C63.10	11.8.2	Option 2

**4.6.4 Test Data**

Mode	CH.	Test Freq. (MHz)	99% Occupied Bandwidth (MHz)	6dB Occupied Bandwidth (kHz)	Limit (kHz)	Result
1	00	2402	1.0841	695.0	>500	Pass
	19	2440	1.0802	693.6	>500	Pass
	39	2480	1.0788	690.3	>500	Pass
2	00	2402	2.1858	1389	>500	Pass
	19	2440	2.1840	1390	>500	Pass
	39	2480	2.1907	1388	>500	Pass
3	00	2402	1.1411	735.8	>500	Pass
	19	2440	1.1431	734.2	>500	Pass
	39	2480	1.1370	734.1	>500	Pass
4	00	2402	1.1396	784.4	>500	Pass
	19	2440	1.1355	784.7	>500	Pass
	39	2480	1.1317	783.1	>500	Pass

Note : The worst case of Occupied Bandwidth as below:

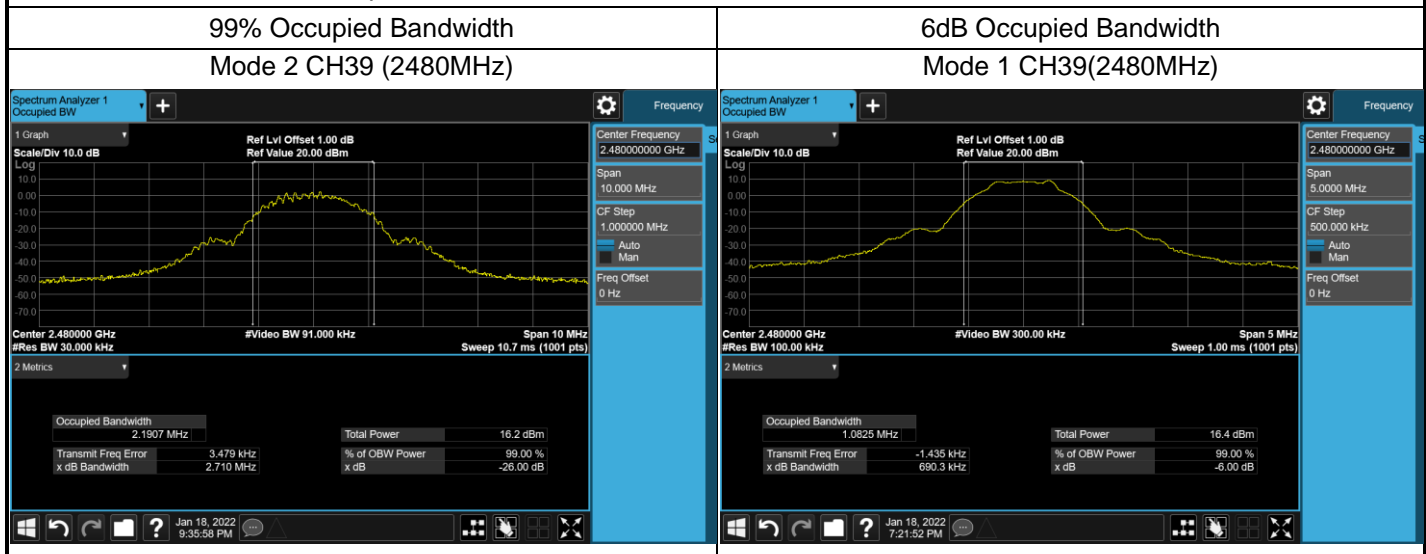

<b>4.7 Fundamental emission output power</b>	<b>VERDICT: PASS</b>
--	----------------------

4.7.1 Limit			
Standard	FCC Part 15 Subpart C Paragraph 15.247 (b)(3)		
<input checked="" type="checkbox"/>	GTX < 6dBi	Pout ≤ 30dBm	
<input type="checkbox"/>	GTX > 6dBi		
<input type="checkbox"/>	Non-Fix point-point	Pout ≤ 30 - (GTX - 6)	
<input type="checkbox"/>	Fix point-point	Pout ≤ 30 - [(GTX - 6)]/3	
<input type="checkbox"/>	Point-to-multipoint	Pout ≤ 30 - (GTX - 6)	
<input type="checkbox"/>	Overlap Beams	Pout ≤ 30 - [(GTX - 6)]/3	
<input type="checkbox"/>	Aggregate power transmitted simultaneously on all beams	Pout ≤ 30 - [(GTX - 6)]/3	
<input type="checkbox"/>	single directional beam	Pout ≤ 30 - [(GTX - 6)]/3 + 8dB	
Note 1 : GTX directional gain of transmitting antennas. Note 2 : Pout is maximum peak conducted output power .			

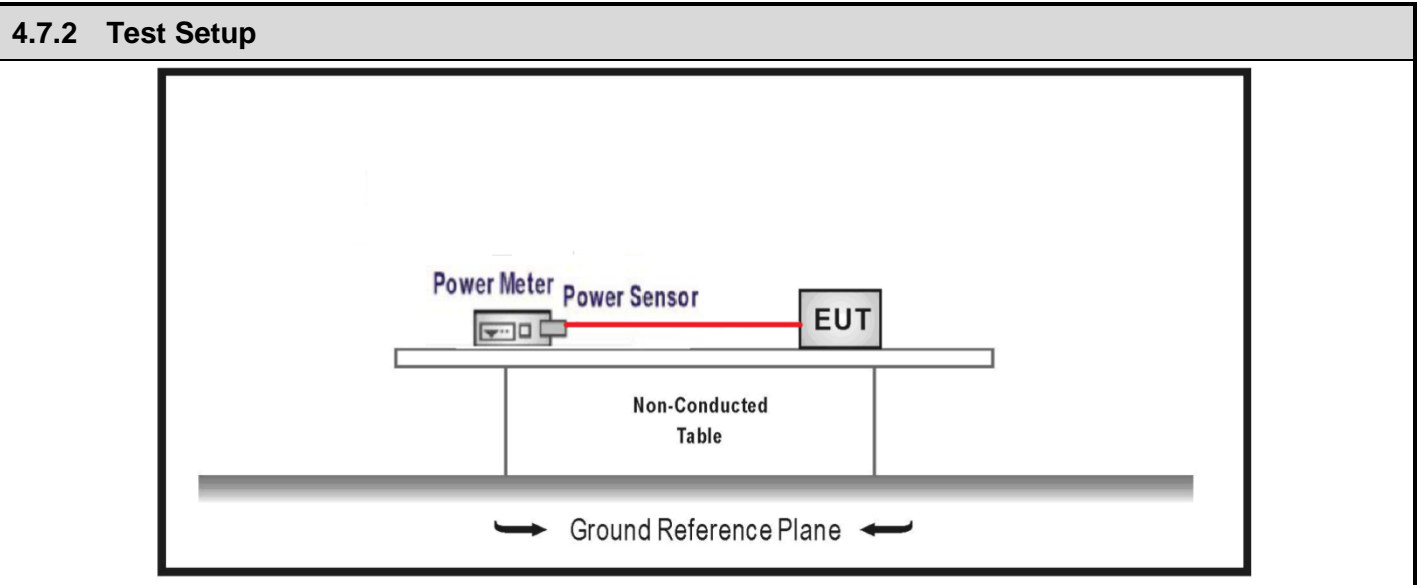

**4.7.3 Test Procedure**

	References Rule	Chapter	Description
<input checked="" type="checkbox"/>	ANSI C63.10	11.9	Fundamental emission output power
<input checked="" type="checkbox"/>	ANSI C63.10	11.9.1	Maximum peak conducted output power
	<input type="checkbox"/> ANSI C63.10	11.9.1.1	RBW ≥ DTS bandwidth
	<input type="checkbox"/> ANSI C63.10	11.9.1.2	Integrated band power method
	<input checked="" type="checkbox"/> ANSI C63.10	11.9.1.3	PKPM1 Peak power meter method
<input type="checkbox"/>	ANSI C63.10	11.9.2	Maximum conducted (average) output power
	<input type="checkbox"/> ANSI C63.10	11.9.2.2	Measurement using a spectrum analyzer (SA)
	<input type="checkbox"/> ANSI C63.10	11.9.2.2.2	Method AVGSA-1(Duty cycle ≥ 98%)
	<input type="checkbox"/> ANSI C63.10	11.9.2.2.3	Method AVGSA-1A(Duty cycle ≥ 98%)
	<input type="checkbox"/> ANSI C63.10	11.9.2.2.4	Method AVGSA-2(Duty cycle ≤ 98%)
	<input type="checkbox"/> ANSI C63.10	11.9.2.2.5	Method AVGSA-2A(Duty cycle ≤ 98%)
	<input type="checkbox"/> ANSI C63.10	11.9.2.2.4	Method AVGSA-3
	<input type="checkbox"/> ANSI C63.10	11.9.2.2.5	Method AVGSA-3A
	<input checked="" type="checkbox"/> ANSI C63.10	11.9.2.3	Measurement using a power meter (PM)
	<input type="checkbox"/> ANSI C63.10	11.9.2.3.1	Method AVGPM
	<input type="checkbox"/> ANSI C63.10	11.9.2.3.2	Method AVGPM-G

#### 4.7.4 Test Data

Mode	Channel	Test Frequency (MHz)	Conducted Power (dBm)	EIRP (dBm)	Conducted Power Limit (dBm)	EIRP Limit (dBm)	Result
Mode 1	00	2402	10.28	13.06	≤30	≤36	Pass
	19	2440	10.07	12.85	≤30	≤36	Pass
	39	2480	10.06	12.84	≤30	≤36	Pass
Mode 2	00	2402	10.37	13.15	≤30	≤36	Pass
	19	2440	10.16	12.94	≤30	≤36	Pass
	39	2480	10.16	12.94	≤30	≤36	Pass
Mode 3	00	2402	10.27	13.05	≤30	≤36	Pass
	19	2440	10.05	12.83	≤30	≤36	Pass
	39	2480	10.05	12.83	≤30	≤36	Pass
Mode 4	00	2402	10.27	13.05	≤30	≤36	Pass
	19	2440	10.06	12.84	≤30	≤36	Pass
	39	2480	10.06	12.84	≤30	≤36	Pass

<b>4.8 Power Density</b>	<b>VERDICT: PASS</b>
--------------------------	----------------------

<b>4.8.1 Limit:</b>	
<b>Standard</b>	FCC Part 15 Subpart C Paragraph 15.247 (b)(3)
Power Spectral Density $\leq 8\text{dBm}/3\text{kHz}$	

**4.8.2 Test Setup**

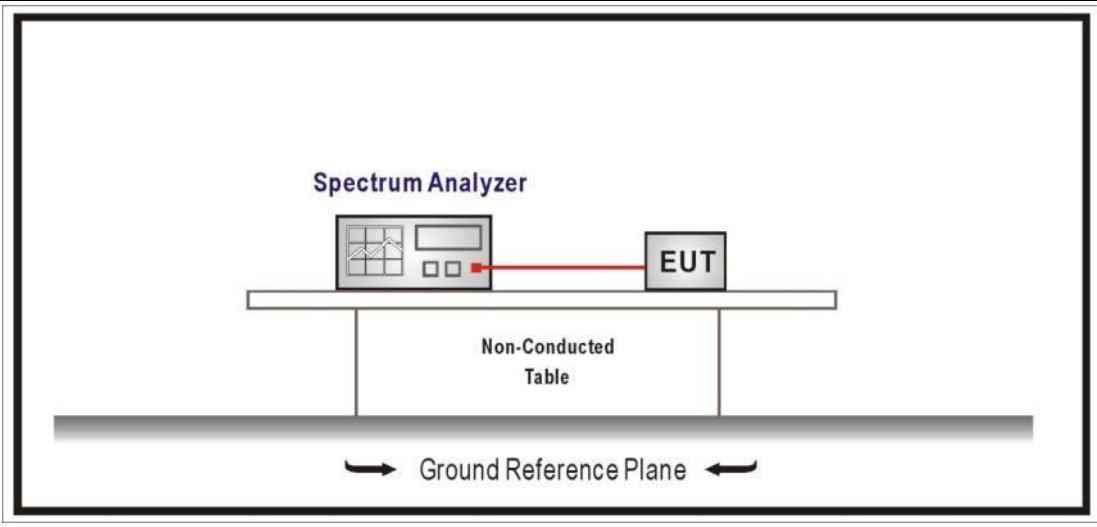

**4.8.3 Test Procedure**

	References Rule	Chapter	Description
<input checked="" type="checkbox"/>	ANSI C63.10	11.10	Maximum power spectral density level in the fundamental emission
<input type="checkbox"/>	ANSI C63.10	11.10.2	Method PKPSD (peak PSD)
<input type="checkbox"/>	ANSI C63.10	11.10.3	Method AVGPSD-1(Duty cycle $\geq 98\%$ )
<input type="checkbox"/>	ANSI C63.10	11.10.4	Method AVGPSD-1A(Duty cycle $\geq 98\%$ )
<input checked="" type="checkbox"/>	ANSI C63.10	11.10.5	Method AVGPSD-2(Duty cycle $< 98\%$ )
<input type="checkbox"/>	ANSI C63.10	11.10.6	Method AVGPSD-2A(Duty cycle $< 98\%$ )
<input type="checkbox"/>	ANSI C63.10	11.10.7	Method AVGPSD-3
<input type="checkbox"/>	ANSI C63.10	11.10.8	Method AVGPSD-3A



### 4.8.4 Test Data

Mode	Channel	Test Frequency (MHz)	Measurement PSD (dBm/3kHz)	Limit (dBm/3kHz)	Result
Mode 1	00	2402	-5.13	≤8	Pass
	19	2440	-5.36	≤8	Pass
	39	2480	-5.25	≤8	Pass
Mode 2	00	2402	-7.87	≤8	Pass
	19	2440	-8.12	≤8	Pass
	39	2480	-8.12	≤8	Pass
Mode 3	00	2402	4.56	≤8	Pass
	19	2440	4.35	≤8	Pass
	39	2480	4.28	≤8	Pass
Mode 4	00	2402	-7.51	≤8	Pass
	19	2440	-7.60	≤8	Pass
	39	2480	-7.63	≤8	Pass

Note : The worst case of PSD as below:

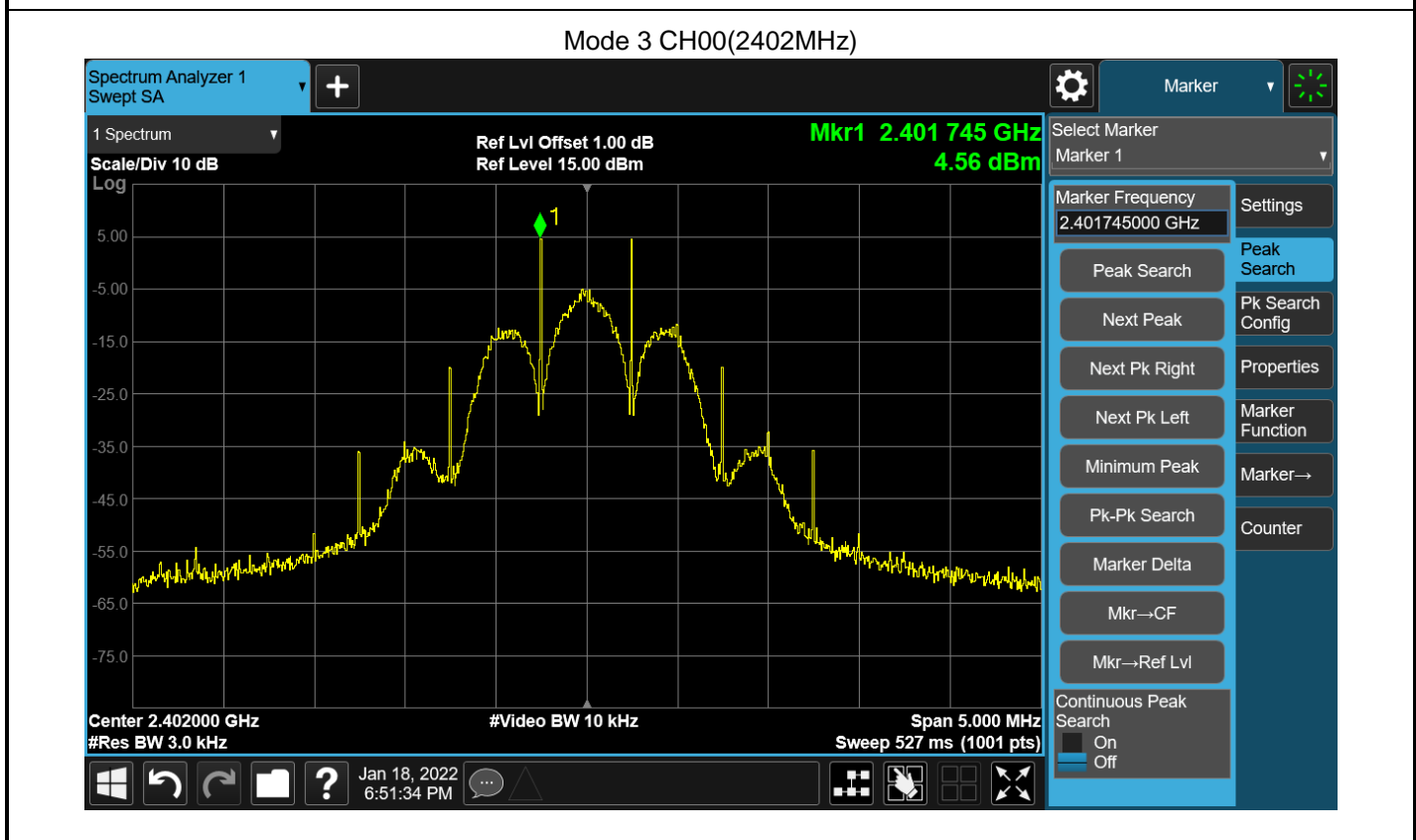

<b>4.9 Antenna Requirement</b>	<b>VERDICT: PASS</b>
--------------------------------	----------------------

<b>4.9.1 Limit:</b>	
<b>Standard</b>	FCC Part 15 Subpart C Paragraph 15.203
<p>An intentional radiator shall be designed to ensure that no antenna other than that furnished by the responsible party shall be used with the device. The use of a permanently attached antenna or of an antenna that uses a unique coupling to the intentional radiator shall be considered sufficient to comply with the provisions of this section. The manufacturer may design the unit so that a broken antenna can be replaced by the user, but the use of a standard antenna jack or electrical connector is prohibited. This requirement does not apply to carrier current devices or to devices operated under the provisions of §15.211, §15.213, §15.217, §15.219, or §15.221. Further, this requirement does not apply to intentional radiators that must be professionally installed, such as perimeter protection systems and some field disturbance sensors, or to other intentional radiators which, in accordance with §15.31(d), must be measured at the installation site. However, the installer shall be responsible for ensuring that the proper antenna is employed so that the limits in this part are not exceeded.</p>	

<b>4.9.2 Antenna Connector Construction:</b>	
<input checked="" type="checkbox"/>	The use of a permanently attached antenna
<input type="checkbox"/>	The antenna use of a unique coupling to the intentional radiator
<input type="checkbox"/>	The use of a nonstandard antenna jack or electrical connector
Please refer to the attached document "Internal Photograph" to show the antenna connector.	

---

## 5 TEST SETUP PHOTO AND EUT PHOTO

Remark: The test setup photo and EUT Photo please see appendix.

\_\_\_\_\_ The End \_\_\_\_\_