



**CFR 47 FCC PART 15 SUBPART C  
ISED RSS-247 ISSUE 2**

**CERTIFICATION TEST REPORT**

*For*

**HUE Smart plug**

**MODEL: 9290022406A**

**FCC ID: 2AGBW9290022406AX**

**IC: 20812-22406AX**

**REPORT NUMBER: 4789870985-2**

**ISSUE DATE: April 8, 2021**

*Prepared for*

**Signify (China) Investment Co., Ltd.  
Building no.9, Lane 888, Tianlin Road, Minhang District Shanghai China**

*Prepared by*

**UL Verification Services (Guangzhou) Co., Ltd, Song Shan Lake Branch  
Building 10, Innovation Technology Park, No. 1, Li Bin Road, Song Shan Lake Hi-Tech Development Zone Dongguan, 523808, People's Republic of China**

**Tel: +86 769 22038881**

**Fax: +86 769 33244054**

**Website: [www.ul.com](http://www.ul.com)**



Revision History

<u>Rev.</u>	<u>Issue Date</u>	<u>Revisions</u>	<u>Revised By</u>
V0	04/09/2021	Initial Issue	



Summary of Test Results			
Clause	Test Items	FCC/ISED Rules	Test Results
1	6dB Bandwidth and 99% Occupied Bandwidth	FCC Part 15.247 (a) (2) RSS-247 Clause 5.2 (a) ISED RSS-Gen Clause 6.7	Pass
2	Peak Conducted Output Power	FCC Part 15.247 (b) (3) RSS-247 Clause 5.4 (d)	Pass
3	Power Spectral Density	FCC Part 15.247 (e) RSS-247 Clause 5.2 (b)	Pass
4	Conducted Bandedge and Spurious Emission	FCC Part 15.247 (d) RSS-247 Clause 5.5	Pass
5	Radiated Bandedge and Spurious Emission	FCC Part 15.247 (d) FCC Part 15.209 FCC Part 15.205 RSS-247 Clause 5.5 RSS-GEN Clause 8.9	Pass
6	Conducted Emission Test for AC Power Port	FCC Part 15.207 RSS-GEN Clause 8.8	Pass
7	Antenna Requirement	FCC Part 15.203 RSS-GEN Clause 6.8	Pass
<b>Note:</b> 1. This test report is only published to and used by the applicant, and it is not for evidence purpose in China. 2. The measurement result for the sample received is <Pass> according to < CFR 47 FCC PART 15 SUBPART C >< ISED RSS-247 > when <Accuracy Method> decision rule is applied.			



## TABLE OF CONTENTS

<b>1. ATTESTATION OF TEST RESULTS</b> .....	<b>6</b>
<b>2. TEST METHODOLOGY</b> .....	<b>7</b>
<b>3. FACILITIES AND ACCREDITATION</b> .....	<b>7</b>
<b>4. CALIBRATION AND UNCERTAINTY</b> .....	<b>8</b>
4.1. <i>MEASURING INSTRUMENT CALIBRATION</i> .....	8
4.2. <i>MEASUREMENT UNCERTAINTY</i> .....	8
<b>5. EQUIPMENT UNDER TEST</b> .....	<b>9</b>
5.1. <i>DESCRIPTION OF EUT</i> .....	9
5.2. <i>CHANNEL LIST</i> .....	9
5.3. <i>MAXIMUM PEAK OUTPUT POWER</i> .....	9
5.4. <i>TEST CHANNEL CONFIGURATION</i> .....	9
5.5. <i>THE WORSE CASE POWER SETTING PARAMETER</i> .....	9
5.6. <i>DESCRIPTION OF AVAILABLE ANTENNAS</i> .....	10
5.7. <i>DESCRIPTION OF TEST SETUP</i> .....	11
<b>6. MEASURING INSTRUMENT AND SOFTWARE USED</b> .....	<b>12</b>
<b>7. ANTENNA PORT TEST RESULTS</b> .....	<b>14</b>
7.1. <i>ON TIME AND DUTY CYCLE</i> .....	14
7.2. <i>6 dB DTS BANDWIDTH AND 99 % OCCUPIED BANDWIDTH</i> .....	15
7.3. <i>CONDUCTED OUTPUT POWER</i> .....	17
7.4. <i>POWER SPECTRAL DENSITY</i> .....	18
7.5. <i>CONDUCTED BANDEDGE AND SPURIOUS EMISSIONS</i> .....	20
<b>8. RADIATED TEST RESULTS</b> .....	<b>22</b>
8.1. <i>RESTRICTED BANDEDGE</i> .....	28
8.2. <i>SPURIOUS EMISSIONS (1 GHz ~ 3 GHz)</i> .....	36
8.3. <i>SPURIOUS EMISSIONS (3 GHz ~ 18 GHz)</i> .....	42
8.4. <i>SPURIOUS EMISSIONS (18 GHz ~ 26 GHz)</i> .....	48
8.5. <i>SPURIOUS EMISSIONS (30 MHz ~ 1 GHz)</i> .....	50
8.6. <i>SPURIOUS EMISSIONS BELOW 30 MHz</i> .....	52
<b>9. AC POWER LINE CONDUCTED EMISSIONS</b> .....	<b>55</b>
9.1. <i>ZIGBEE MODE</i> .....	56
<b>10. ANTENNA REQUIREMENTS</b> .....	<b>58</b>
10.1. <i>Appendix A: DTS Bandwidth</i> .....	59



---

10.1.1.	Test Result.....	59
10.1.2.	Test Graphs .....	60
10.2.	<i>Appendix B: Occupied Channel Bandwidth .....</i>	<i>61</i>
10.2.1.	Test Result.....	61
10.2.2.	Test Graphs .....	62
10.3.	<i>Appendix C: Maximum conducted output power .....</i>	<i>63</i>
10.3.1.	Test Result.....	63
10.4.	<i>Appendix D: Maximum power spectral density .....</i>	<i>64</i>
10.4.1.	Test Result.....	64
10.4.2.	Test Graphs .....	65
10.5.	<i>Appendix E: Band edge measurements .....</i>	<i>66</i>
10.5.1.	Test Result.....	66
10.5.2.	Test Graphs .....	67
10.6.	<i>Appendix F: Conducted Spurious Emission.....</i>	<i>68</i>
10.6.1.	Test Result.....	68
10.6.1.	Test Graphs .....	69
10.7.	<i>Appendix G: Duty Cycle.....</i>	<i>74</i>
10.7.1.	Test Result.....	74
10.7.2.	Test Graphs .....	75



# 1. ATTESTATION OF TEST RESULTS

## Applicant Information

Company Name: Signify (China) Investment Co., Ltd.  
 Address: Building no.9, Lane 888, Tianlin Road, Minhang District Shanghai  
 China

## Manufacturer Information

Company Name: Signify (China) Investment Co., Ltd.  
 Address: Building no.9, Lane 888, Tianlin Road, Minhang District Shanghai  
 China

## EUT Information

EUT Name: HUE Smart plug  
 Model: 9290022406A  
 Brand: PHILIPS  
 Sample Received Date: March 29, 2021  
 Sample Status: Normal  
 Sample ID: 3750387  
 Date of Tested: March 29 ~ May 31, 2021

APPLICABLE STANDARDS	
STANDARD	TEST RESULTS
CFR 47 FCC PART 15 SUBPART C	PASS
ISED RSS-247 Issue 2	PASS
ISED RSS-GEN Issue 5	PASS

Prepared By:

Checked By:

Kebo Zhang  
 Project Engineer

Shawn Wen  
 Laboratory Leader

Approved By:

Stephen Guo  
 Laboratory Manager



## 2. TEST METHODOLOGY

The tests documented in this report were performed in accordance with KDB 558074 D01 15.247 Meas Guidance v05r02, 414788 D01 Radiated Test Site v01r01, CFR 47 FCC Part 2, CFR 47 FCC Part 15, ANSI C63.10-2013, ISED RSS-247 Issue 2 and ISED RSS-GEN Issue 5.

## 3. FACILITIES AND ACCREDITATION

Accreditation Certificate	<p><b>A2LA (Certificate No.: 4102.01)</b> UL Verification Services (Guangzhou) Co., Ltd. Song Shan Lake Branch. has been assessed and proved to be in compliance with A2LA.</p> <p><b>FCC (FCC Designation No.: CN1187)</b> UL Verification Services (Guangzhou) Co., Ltd. Song Shan Lake Branch. Has been recognized to perform compliance testing on equipment subject to the Commission's Declaration of Conformity (DoC) and Certification rules</p> <p><b>ISED(Company No.: 21320)</b> UL Verification Services (Guangzhou) Co., Ltd. Song Shan Lake Branch. has been registered and fully described in a report filed with ISED. The Company Number is 21320.</p> <p><b>VCCI (Registration No.: G-20019, R-20004, C-20012 and T-20011)</b> UL Verification Services (Guangzhou) Co., Ltd. Song Shan Lake Branch. has been assessed and proved to be in compliance with VCCI, the Membership No. is 3793. Facility Name: Chamber D, the VCCI registration No. is G-20019 and R-20004 Shielding Room B , the VCCI registration No. is C-20012 and T-20011</p>
---------------------------	---

Note 1: All tests measurement facilities use to collect the measurement data are located at Building 10, Innovation Technology Park, Song Shan Lake Hi tech Development Zone, Dongguan, 523808, China

Note 2: The test anechoic chamber in UL Verification Services (Guangzhou) Co., Ltd. Song Shan Lake Branch had been calibrated and compared to the open field sites and the test anechoic chamber is shown to be equivalent to or worst case from the open field site.

Note 3: For below 30 MHz, lab had performed measurements at test anechoic chamber and comparing to measurements obtained on an open field site. And these measurements below 30 MHz had been correlated to measurements performed on an OFS.



## 4. CALIBRATION AND UNCERTAINTY

### 4.1. MEASURING INSTRUMENT CALIBRATION

The measuring equipment utilized to perform the tests documented in this report has been calibrated in accordance with the manufacturer's recommendations and is traceable to recognize national standards.

### 4.2. MEASUREMENT UNCERTAINTY

Where relevant, the following measurement uncertainty levels have been estimated for tests performed on the apparatus:

Test Item	Uncertainty
Conduction emission	3.62 dB
Radiated Emission (Included Fundamental Emission) (9 kHz ~ 30 MHz)	2.2 dB
Radiated Emission (Included Fundamental Emission) (30 MHz ~ 1 GHz)	4.00 dB
Radiated Emission (Included Fundamental Emission) (1 GHz to 26 GHz)	5.78 dB (1 GHz ~ 18 GHz)
	5.23 dB (18 GHz ~ 26 GHz)
Duty Cycle	±0.028%
DTS and 99% Occupied Bandwidth	±0.0196%
Maximum Conducted Output Power	±0.686 dB
Maximum Power Spectral Density Level	±0.743 dB
Conducted Band-edge Compliance	±1.328 dB
Conducted Unwanted Emissions In Non-restricted Frequency Bands	±0.746 dB (9 kHz ~ 1 GHz)
	±1.328dB (1 GHz ~ 26 GHz)
Note: This uncertainty represents an expanded uncertainty expressed at approximately the 95% confidence level using a coverage factor of k=2.	





## 5. EQUIPMENT UNDER TEST

### 5.1. DESCRIPTION OF EUT

EUT Name	HUE Smart plug		
Model	9290022406A		
Product Description	Operation Frequency	2405 MHz ~ 2480 MHz	
	Modulation Type	Data Rate	
	O-QPSK	250kbps	
Radio technology	Zigbee 3.0		
Rated Input	AC120 V,60 Hz		

### 5.2. CHANNEL LIST

Channel	Frequency (MHz)	Channel	Frequency (MHz)	Channel	Frequency (MHz)	Channel	Frequency (MHz)
11	2405	15	2425	19	2445	23	2465
12	2410	16	2430	20	2450	24	2470
13	2415	17	2435	21	2455	25	2475
14	2420	18	2440	22	2460	26	2480

### 5.3. MAXIMUM PEAK OUTPUT POWER

Mode	Frequency (MHz)	Channel Number	Max Output PEAK Power (dBm)
Zigbee	2405-2480	11-26 [16]	9.04

### 5.4. TEST CHANNEL CONFIGURATION

Test Mode	Test Channel	Frequency
ZigBee	CH 11, CH 19, CH 26	2405MHz, 2445MHz, 2480MHz

### 5.5. THE WORSE CASE POWER SETTING PARAMETER

The Worse Case Power Setting Parameter under 2400 ~ 2483.5MHz Band				
Test Software		UartAssis		
Modulation Type	Transmit Antenna Number	Test Channel		
		CH 11	CH 19	CH 26
O-QPSK	1	10	10	10



### 5.6. DESCRIPTION OF AVAILABLE ANTENNAS

Ant.	Frequency (MHz)	Antenna Type	Antenna Gain (dBi)
1	2405-2480	Built-in	1.5

Test Mode	Transmit and Receive Mode	Description
Zigbee	<input checked="" type="checkbox"/> 1TX, 1RX	Chain 1 can be used as transmitting/receiving antenna.

Note: 1. The value of the antenna gain was declared by customer.

## 5.7. DESCRIPTION OF TEST SETUP

### SUPPORT EQUIPMENT

Item	Equipment	Brand Name	Model Name	Remarks
1	Laptop	ThinkPad	X230i	/
2	USB TO UART	/	/	/
3	LED Lamp	N/A	N/A	100W

### I/O CABLES

Item	Port	Connector Type	Cable Type	Cable Length(m)	Remarks
1	USB	NA	NA	1	/

### ACCESSORIES

Item	Accessory	Brand Name	Model Name	Description
/	/	/	/	/

### TEST SETUP

The EUT can work in an engineer mode with a software through a PC.

### SETUP DIAGRAM FOR TESTS

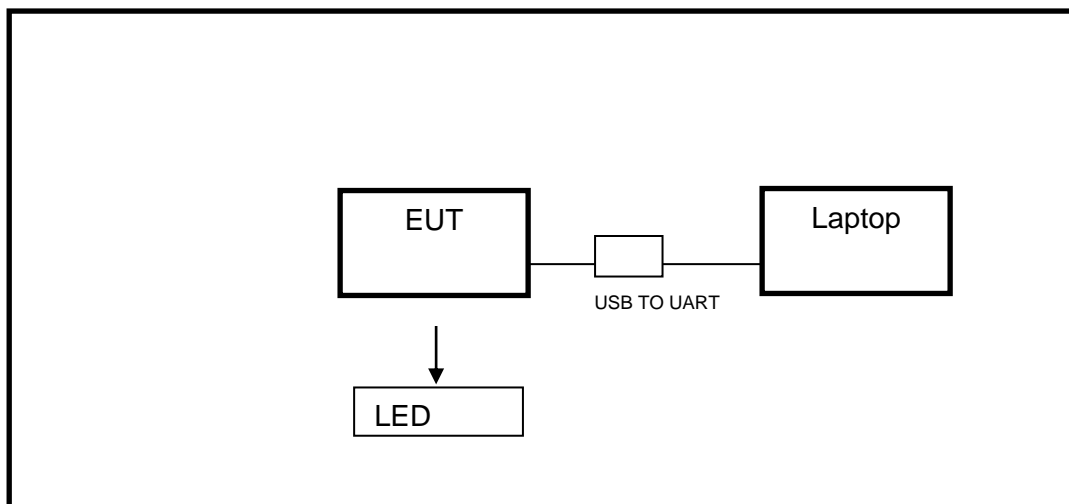

**6. MEASURING INSTRUMENT AND SOFTWARE USED**

Conducted Emissions					
Equipment	Manufacturer	Model No.	Serial No.	Last Cal.	Due Date
EMI Test Receiver	R&S	ESR3	101961	Nov. 12, 2020	Nov. 11, 2021
Two-Line V-Network	R&S	ENV216	101983	Nov. 12, 2020	Nov. 11, 2021
Artificial Mains Networks	Schwarzbeck	NSLK 8126	8126465	Nov. 12, 2020	Nov. 11, 2021
Software					
Description			Manufacturer	Name	Version
Test Software for Conducted Emissions			Farad	EZ-EMC	Ver. UL-3A1

Radiated Emissions					
Equipment	Manufacturer	Model No.	Serial No.	Last Cal.	Due Date
MXE EMI Receiver	KESIGHT	N9038A	MY56400036	Nov. 12, 2020	Nov. 11, 2021
Hybrid Log Periodic Antenna	TDK	HLP-3003C	130960	Aug. 11, 2018	Aug. 10, 2021
Preamplifier	HP	8447D	2944A09099	Nov. 12, 2020	Nov. 11, 2021
EMI Measurement Receiver	R&S	ESR26	101377	Nov. 12, 2020	Nov. 11, 2021
Horn Antenna	TDK	HRN-0118	130939	Sept. 17, 2018	Sept. 17, 2021
Preamplifier	TDK	PA-02-0118	TRS-305-00067	Nov. 20, 2020	Nov. 19, 2021
Horn Antenna	Schwarzbeck	BBHA9170	#691	Aug. 11, 2018	Aug. 11, 2021
Preamplifier	TDK	PA-02-2	TRS-307-00003	Nov. 12, 2020	Nov. 11, 2021
Preamplifier	TDK	PA-02-3	TRS-308-00002	Nov. 12, 2020	Nov. 11, 2021
Loop antenna	Schwarzbeck	1519B	00008	Jan.17, 2019	Jan.17,2022
Preamplifier	TDK	PA-02-001-3000	TRS-302-00050	Nov. 12, 2020	Nov. 11, 2021
Preamplifier	Mini-Circuits	ZX60-83LN-S+	SUP01201941	Nov. 20, 2020	Nov. 19, 2021
High Pass Filter	Wi	WHKX10-2700-3000-18000-40SS	23	Nov. 12, 2020	Nov. 11, 2021
Band Reject Filter	Wainwright	WRCJV8-2350-2400-2483.5-2533.5-40SS	4	Nov. 12, 2020	Nov. 11, 2021



Software			
Description	Manufacturer	Name	Version
Test Software for Radiated Emissions	Farad	EZ-EMC	Ver. UL-3A1

Other instruments					
Equipment	Manufacturer	Model No.	Serial No.	Last Cal.	Next Cal.
Spectrum Analyzer	Keysight	N9030A	MY55410512	Nov. 20, 2020	Nov. 19, 2021
Dual Channel Power Meter	Keysight	N1912A	MY55416024	Nov. 20, 2020	Nov. 19, 2021
Power Sensor	Keysight	USB Wideband Power Sensor	MY5100022	Nov. 20, 2020	Nov. 19, 2021

## 7. ANTENNA PORT TEST RESULTS

### 7.1. ON TIME AND DUTY CYCLE

#### LIMITS

None; for reporting purposes only.

#### PROCEDURE

Refer to ANSI C63.10-2013 clause 11.6 Zero – Span Spectrum Analyzer method.

#### TEST SETUP

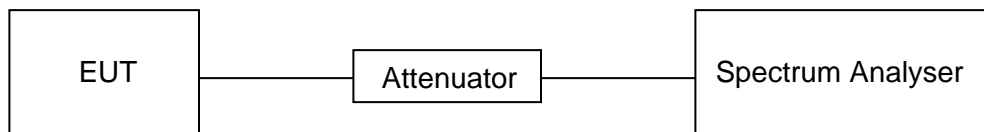

#### TEST ENVIRONMENT

Temperature	25.8 °C	Relative Humidity	58.4 %
Atmosphere Pressure	101 kPa	Test Voltage	AC120 V,60 Hz

#### RESULTS

Please refer to appendix G.

## 7.2. 6 dB DTS BANDWIDTH AND 99 % OCCUPIED BANDWIDTH

### LIMITS

CFR 47FCC Part15 (15.247) Subpart C ISED RSS-247 ISSUE 2			
Section	Test Item	Limit	Frequency Range (MHz)
CFR 47 FCC 15.247(a)(2) ISED RSS-247 5.2 (a)	6 dB Bandwidth	≥ 500 kHz	2400-2483.5
ISED RSS-Gen Clause 6.7	99 % Occupied Bandwidth	None; for reporting purposes only.	2400-2483.5

### TEST PROCEDURE

Connect the EUT to the spectrum analyser and use the following settings:

Center Frequency	The center frequency of the channel under test
Frequency Span	For 6 dB Bandwidth: Enough to capture all products of the modulation carrier emission For 99 % Occupied Bandwidth: Between 1.5 times and 5.0 times the OBW
Detector	Peak
RBW	For 6 dB Bandwidth: 100 kHz For 99 % Occupied Bandwidth: 1 % to 5 % of the occupied bandwidth
VBW	For 6 dB Bandwidth: ≥3 × RBW For 99 % Occupied Bandwidth: ≥3 × RBW
Trace	Max hold
Sweep	Auto couple

a) Use the 99 % power bandwidth function of the instrument, allow the trace to stabilize and report the measured bandwidth.

b) Allow the trace to stabilize and measure the maximum width of the emission that is constrained by the frequencies associated with the two outermost amplitude points (upper and lower frequencies) that are attenuated by 6 dB relative to the maximum level measured in the fundamental emission.

### TEST SETUP

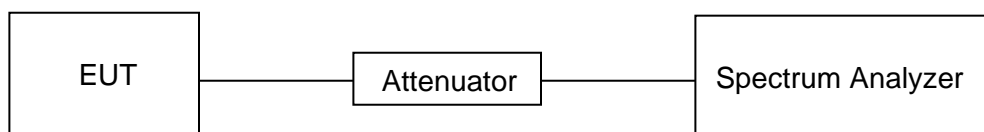



**TEST ENVIRONMENT**

Temperature	25.8 °C	Relative Humidity	58.4 %
Atmosphere Pressure	101 kPa	Test Voltage	AC120 V,60 Hz

**RESULTS**

Please refer to appendix A & B.



### 7.3. CONDUCTED OUTPUT POWER

#### LIMITS

CFR 47 FCC Part15 (15.247) Subpart C ISED RSS-247 ISSUE 2			
Section	Test Item	Limit	Frequency Range (MHz)
CFR 47 FCC 15.247(b)(3) ISED RSS-247 5.4 (d)	Peak Conducted Output Power	1 watt or 30 dBm	2400-2483.5

#### TEST PROCEDURE

Connect the EUT to a low loss RF cable from the antenna port to the power sensor (video bandwidth is greater than the occupied bandwidth).  
Measure peak emission level, the indicated level is the peak output power, after any corrections for external attenuators and cables.

#### TEST SETUP

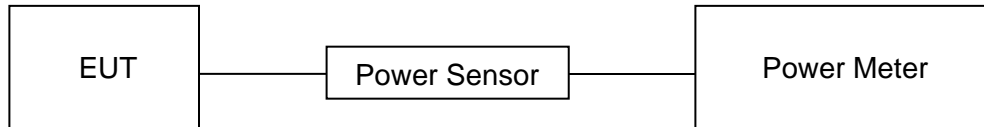

#### TEST ENVIRONMENT

Temperature	25.8 °C	Relative Humidity	58.4 %
Atmosphere Pressure	101 kPa	Test Voltage	AC120 V,60 Hz

#### RESULTS

Please refer to appendix C.

## 7.4. POWER SPECTRAL DENSITY

### LIMITS

CFR 47 FCC Part15 (15.247) Subpart C ISED RSS-247 ISSUE 2			
Section	Test Item	Limit	Frequency Range (MHz)
CFR 47 FCC §15.247 (e) ISED RSS-247 5.2 (b)	Power Spectral Density	8 dBm in any 3 kHz band	2400-2483.5

### TEST PROCEDURE

Connect the EUT to the spectrum analyser and use the following settings:

Center Frequency	The center frequency of the channel under test
Detector	Peak
RBW	$3 \text{ kHz} \leq \text{RBW} \leq 100 \text{ kHz}$
VBW	$\geq 3 \times \text{RBW}$
Span	1.5 x DTS bandwidth
Trace	Max hold
Sweep time	Auto couple

Allow trace to fully stabilize and use the peak marker function to determine the maximum amplitude level within the RBW.

If measured value exceeds limit, reduce RBW (no less than 3 kHz) and repeat.

### TEST SETUP

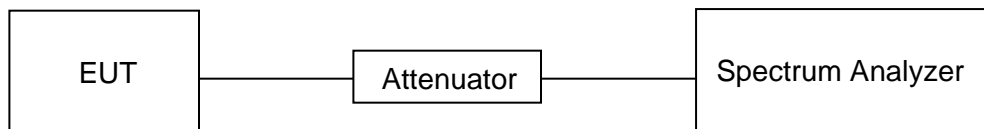

### TEST ENVIRONMENT

Temperature	25.8 °C	Relative Humidity	58.4 %
Atmosphere Pressure	101 kPa	Test Voltage	AC120 V,60 Hz



---

**RESULTS**

Please refer to appendix D.



## 7.5. CONDUCTED BANDEGE AND SPURIOUS EMISSIONS

### LIMITS

CFR 47 FCC Part15 (15.247) Subpart C ISED RSS-247 ISSUE 2		
Section	Test Item	Limit
CFR 47 FCC §15.247 (d) ISED RSS-247 5.5	Conducted Bandedge and Spurious Emissions	at least 20 dB below that in the 100 kHz bandwidth within the band that contains the highest level of the desired power

### TEST PROCEDURE

Connect the EUT to the spectrum analyser and use the following settings for reference level measurement:

Center Frequency	The center frequency of the channel under test
Detector	Peak
RBW	100 kHz
VBW	$\geq 3 \times \text{RBW}$
Span	1.5 x DTS bandwidth
Trace	Max hold
Sweep time	Auto couple.

Allow trace to fully stabilize and use the peak marker function to determine the maximum PSD level.

Change the settings for emission level measurement:

Span	Set the center frequency and span to encompass frequency range to be measured
Detector	Peak
RBW	100 kHz
VBW	$\geq 3 \times \text{RBW}$
measurement points	$\geq \text{span}/\text{RBW}$
Trace	Max hold
Sweep time	Auto couple.

Allow trace to fully stabilize and use the peak marker function to determine the maximum PSD level. Ensure that the amplitude of all unwanted emissions outside of the authorized frequency band (excluding restricted frequency bands) is attenuated by at least the minimum requirements specified in 11.11.



**TEST SETUP**

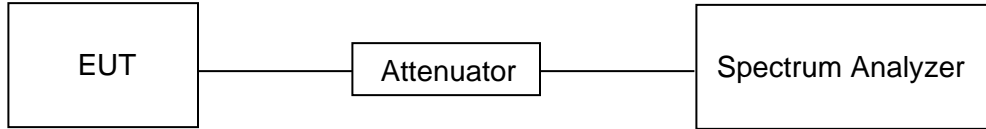

**TEST ENVIRONMENT**

Temperature	25.8 °C	Relative Humidity	58.4 %
Atmosphere Pressure	101 kPa	Test Voltage	AC120 V,60 Hz

**RESULTS**

Please refer to appendix E & F.



## 8. RADIATED TEST RESULTS

### LIMITS

Please refer to CFR 47 FCC §15.205 and §15.209.

Please refer to ISED RSS-GEN Clause 8.9 and Clause 8.10.

Radiation Disturbance Test Limit for FCC (Class B) (9 kHz-1 GHz)

Emissions radiated outside of the specified frequency bands above 30 MHz			
Frequency Range (MHz)	Field Strength Limit (uV/m) at 3 m	Field Strength Limit (dBuV/m) at 3 m	
		Quasi-Peak	
30 - 88	100	40	
88 - 216	150	43.5	
216 - 960	200	46	
Above 960	500	54	
Above 1000	500	Peak	Average
		74	54

FCC Emissions radiated outside of the specified frequency bands below 30 MHz		
Frequency (MHz)	Field strength (microvolts/meter)	Measurement distance (meters)
0.009-0.490	2400/F(kHz)	300
0.490-1.705	24000/F(kHz)	30
1.705-30.0	30	30

ISED General field strength limits at frequencies below 30 MHz

Table 6 – General field strength limits at frequencies below 30 MHz		
Frequency	Magnetic field strength (H-Field) (µA/m)	Measurement distance (m)
9 - 490 kHz <sup>Note 1</sup>	6.37/F (F in kHz)	300
490 - 1705 kHz	63.7/F (F in kHz)	30
1.705 - 30 MHz	0.08	30

**Note 1:** The emission limits for the ranges 9-90 kHz and 110-490 kHz are based on measurements employing a linear average detector.



ISED Restricted bands please refer to ISED RSS-GEN Clause 8.10

Table 7 – Restricted frequency bands <sup>Note 1</sup>		
MHz	MHz	GHz
0.090 - 0.110	149.9 - 150.05	9.0 - 9.2
0.495 - 0.505	156.52475 - 156.52525	9.3 - 9.5
2.1735 - 2.1905	156.7 - 156.9	10.6 - 12.7
3.020 - 3.026	162.0125 - 167.17	13.25 - 13.4
4.125 - 4.128	167.72 - 173.2	14.47 - 14.5
4.17725 - 4.17775	240 - 285	15.35 - 16.2
4.20725 - 4.20775	322 - 335.4	17.7 - 21.4
5.677 - 5.683	399.9 - 410	22.01 - 23.12
6.215 - 6.218	608 - 614	23.6 - 24.0
6.26775 - 6.26825	960 - 1427	31.2 - 31.8
6.31175 - 6.31225	1435 - 1626.5	36.43 - 36.5
8.291 - 8.294	1645.5 - 1646.5	Above 38.6
8.362 - 8.366	1660 - 1710	
8.37625 - 8.38675	1718.8 - 1722.2	
8.41425 - 8.41475	2200 - 2300	
12.29 - 12.293	2310 - 2390	
12.51975 - 12.52025	2483.5 - 2500	
12.57675 - 12.57725	2655 - 2900	
13.36 - 13.41	3260 - 3267	
16.42 - 16.423	3332 - 3339	
16.69475 - 16.69525	3345.8 - 3358	
16.80425 - 16.80475	3500 - 4400	
25.5 - 25.67	4500 - 5150	
37.5 - 38.25	5350 - 5460	
73 - 74.6	7260 - 7750	
74.8 - 75.2	8025 - 8500	
108 - 138		

**Note 1:** Certain frequency bands listed in table 7 and in bands above 38.6 GHz are designated for licence-exempt applications. These frequency bands and the requirements that apply to related devices are set out in the 200 and 300 series of RSSs.

FCC Restricted bands of operation refer to FCC §15.205 (a):

MHz	MHz	MHz	GHz
0.090-0.110	16.42-16.423	399.9-410	4.5-5.15
<sup>1</sup> 0.495-0.505	16.69475-16.69525	608-614	5.35-5.46
2.1735-2.1905	16.80425-16.80475	960-1240	7.25-7.75
4.125-4.128	25.5-25.67	1300-1427	8.025-8.5
4.17725-4.17775	37.5-38.25	1435-1626.5	9.0-9.2
4.20725-4.20775	73-74.6	1645.5-1646.5	9.3-9.5
6.215-6.218	74.8-75.2	1660-1710	10.6-12.7
6.26775-6.26825	108-121.94	1718.8-1722.2	13.25-13.4
6.31175-6.31225	123-138	2200-2300	14.47-14.5
8.291-8.294	149.9-150.05	2310-2390	15.35-16.2
8.362-8.366	156.52475-156.52525	2483.5-2500	17.7-21.4
8.37625-8.38675	156.7-156.9	2690-2900	22.01-23.12
8.41425-8.41475	162.0125-167.17	3260-3267	23.6-24.0
12.29-12.293	167.72-173.2	3332-3339	31.2-31.8
12.51975-12.52025	240-285	3345.8-3358	36.43-36.5
12.57675-12.57725	322-335.4	3600-4400	( <sup>2</sup> )
13.36-13.41			

Note: <sup>1</sup>Until February 1, 1999, this restricted band shall be 0.490-0.510 MHz.

<sup>2</sup>Above 38.6c

## TEST SETUP AND PROCEDURE

Below 30 MHz

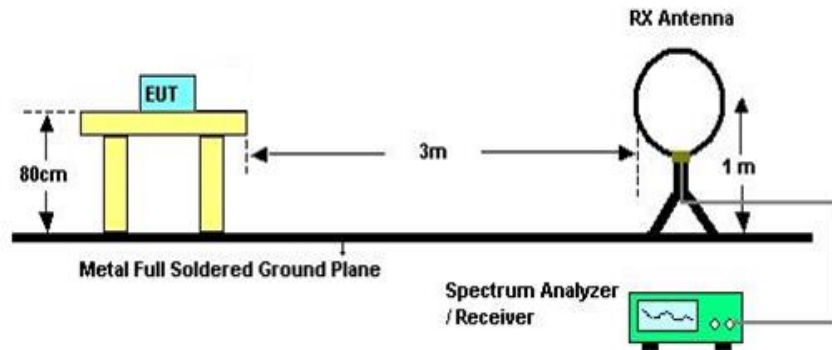

The setting of the spectrum analyser

RBW	200 Hz (From 9 kHz to 0.15 MHz)/ 9 kHz (From 0.15 MHz to 30 MHz)
VBW	200 Hz (From 9 kHz to 0.15 MHz)/ 9 kHz (From 0.15 MHz to 30 MHz)
Sweep	Auto
Trace	Max hold

1. The testing follows the guidelines in ANSI C63.10-2013 clause 6.4.
2. The EUT was arranged to its worst case and then turntable (from 0 degree to 360 degrees) to find the maximum reading. A pre-amp and a high pass filter are used for the test in order to get better signal level. Both Horizontal, Face-on and Face-off polarizations of the antenna are set to make the measurement.
3. The EUT was placed on a turntable with 80 cm above ground.
4. The EUT was set 3 meters from the interference receiving antenna, which was mounted on the top of a 1 m height antenna tower.
5. The radiated emission limits are based on measurements employing a CISPR quasi-peak detector except for the frequency bands 9-90 kHz, 110-490 kHz and above 1000 MHz. Radiated emission limits in these three bands are based on measurements employing an average detector.
6. For measurement below 1 GHz, the initial step in collecting conducted emission data is a spectrum analyzer peak detector mode pre-scanning the measurement frequency range. Significant peaks are then marked and then Quasi Peak and average detector mode re-measured. If the emission level of the EUT measured by the peak detector is 3 dB lower than the applicable limit, the peak emission level will be reported. Otherwise, the emission measurement will be repeated using the quasi-peak and average detector and reported.
7. Although these tests were performed other than open field site, adequate comparison measurements were confirmed against 30m open field site. Therefore sufficient tests were made to demonstrate that the alternative site produces results that correlate with the ones of tests made in an open field site based on KDB 414788.
8. The limits in CFR 47, Part 15, Subpart C, paragraph 15.209 (a), are identical to those in RSS-GEN Section 8.9, Table 6, since the measurements are performed in terms of magnetic field strength and converted to electric field strength levels (as reported in the table) using the free space impedance of  $377\Omega$ . For example, the measurement frequency X KHz resulted in a level of Y dBuV/m, which is equivalent to  $Y-51.5 = Z$  dBuA/m, which has the same margin, W dB, to the corresponding RSS-GEN Table 6 limit as it has to be 15.209(a) limit.



Below 1 GHz and above 30 MHz

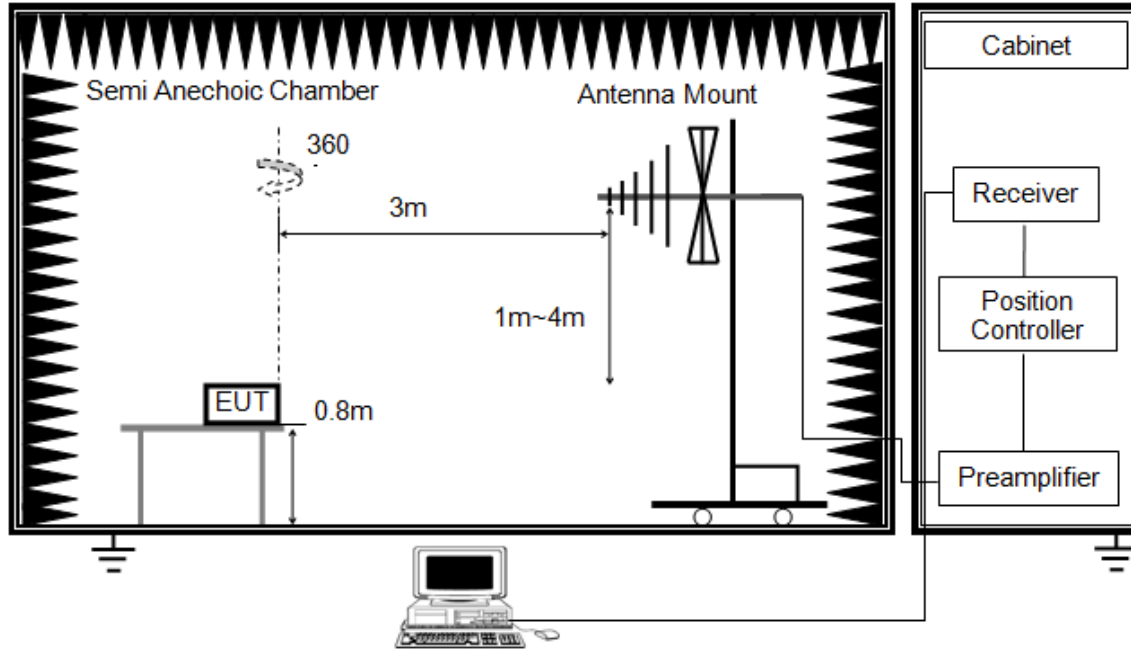

The setting of the spectrum analyser

RBW	120 kHz
VBW	300 kHz
Sweep	Auto
Detector	Peak/QP
Trace	Max hold

1. The testing follows the guidelines in ANSI C63.10-2013 clause 6.5.
2. The EUT was arranged to its worst case and then tune the antenna tower (from 1 m to 4 m) and turntable (from 0 degree to 360 degrees) to find the maximum reading. A pre-amp and a high pass filter are used for the test in order to get better signal level. Both horizontal and vertical polarizations of the antenna are set to make the measurement.
3. The EUT was placed on a turntable with 80 cm above ground.
4. The EUT was set 3 meters from the interference receiving antenna, which was mounted on the top of a variable height antenna tower.
5. For measurement below 1 GHz, the initial step in collecting conducted emission data is a spectrum analyzer peak detector mode pre-scanning the measurement frequency range. Significant peaks are then marked and then Quasi Peak detector mode re-measured. If the emission level of the EUT measured by the peak detector is 3 dB lower than the applicable limit, the peak emission level will be reported. Otherwise, the emission measurement will be repeated using the quasi-peak detector and reported.

Above 1 GHz

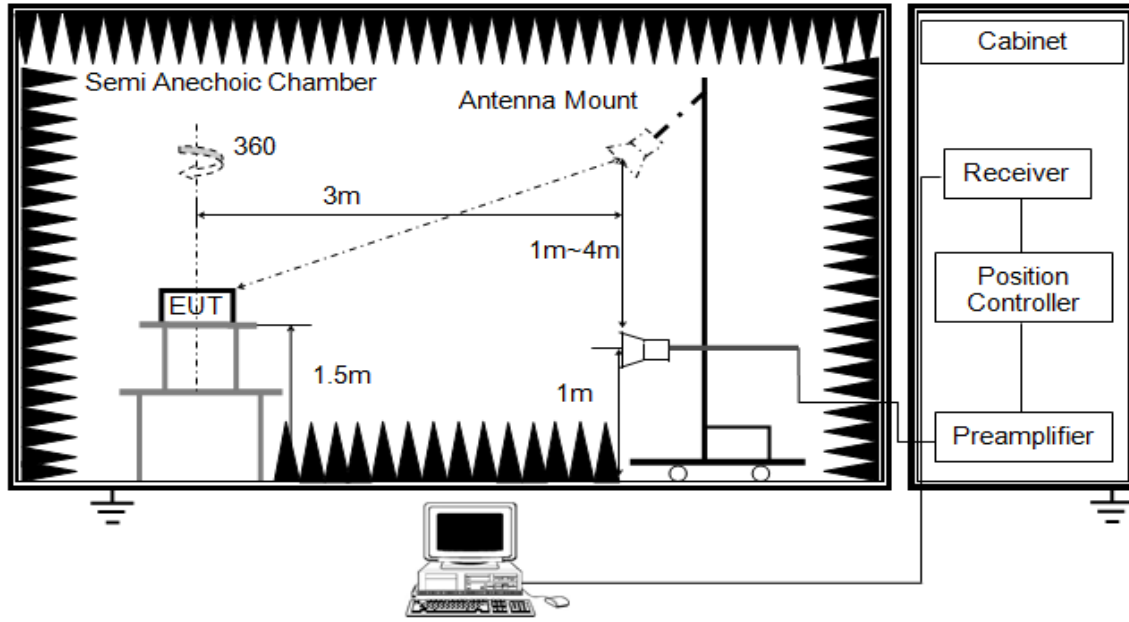

The setting of the spectrum analyser

RBW	1 MHz
VBW	PEAK: 3 MHz AVG: see note 6
Sweep	Auto
Detector	Peak
Trace	Max hold

1. The testing follows the guidelines in ANSI C63.10-2013 clause 6.6.
2. The EUT was arranged to its worst case and then tune the antenna tower (from 1 m to 4 m) and turntable (from 0 degree to 360 degrees) to find the maximum reading. A pre-amp and a high pass filter are used for the test in order to get better signal level. Both horizontal and vertical polarizations of the antenna are set to make the measurement.
3. The EUT was placed on a turntable with 1.5 m above ground.
4. The EUT was set 3 meters from the interference receiving antenna, which was mounted on the top of a variable height antenna tower.
5. For measurement above 1 GHz, the emission measurement will be measured by the peak detector. This peak level, once corrected, must comply with the limit specified in Section 15.209.
6. For measurements above 1 GHz the resolution bandwidth is set to 1 MHz, then the video bandwidth is set to 3 MHz for peak measurements and 1 MHz resolution bandwidth with 1/T video bandwidth with peak detector for average measurements. For the Duty Cycle please refer to clause 7.1.ON TIME AND DUTY CYCLE.

X axis, Y axis, Z axis positions:

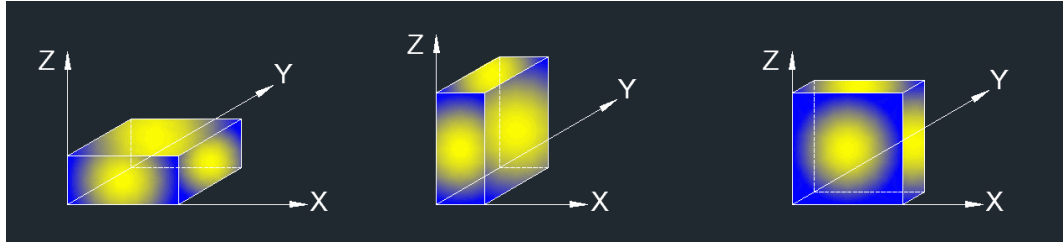

Note 1: For all radiated test, EUT in each of three orthogonal axis emissions had been tested, but only the worst case (X axis) data recorded in the report.

### **TEST ENVIRONMENT**

Temperature	19.3 °C	Relative Humidity	50.6 %
Atmosphere Pressure	101 kPa	Test Voltage	AC120 V,60 Hz

### **RESULTS**



## 8.1. RESTRICTED BANDEDGE

### RESTRICTED BANDEDGE (CHANNEL 11, HORIZONTAL)

#### PEAK

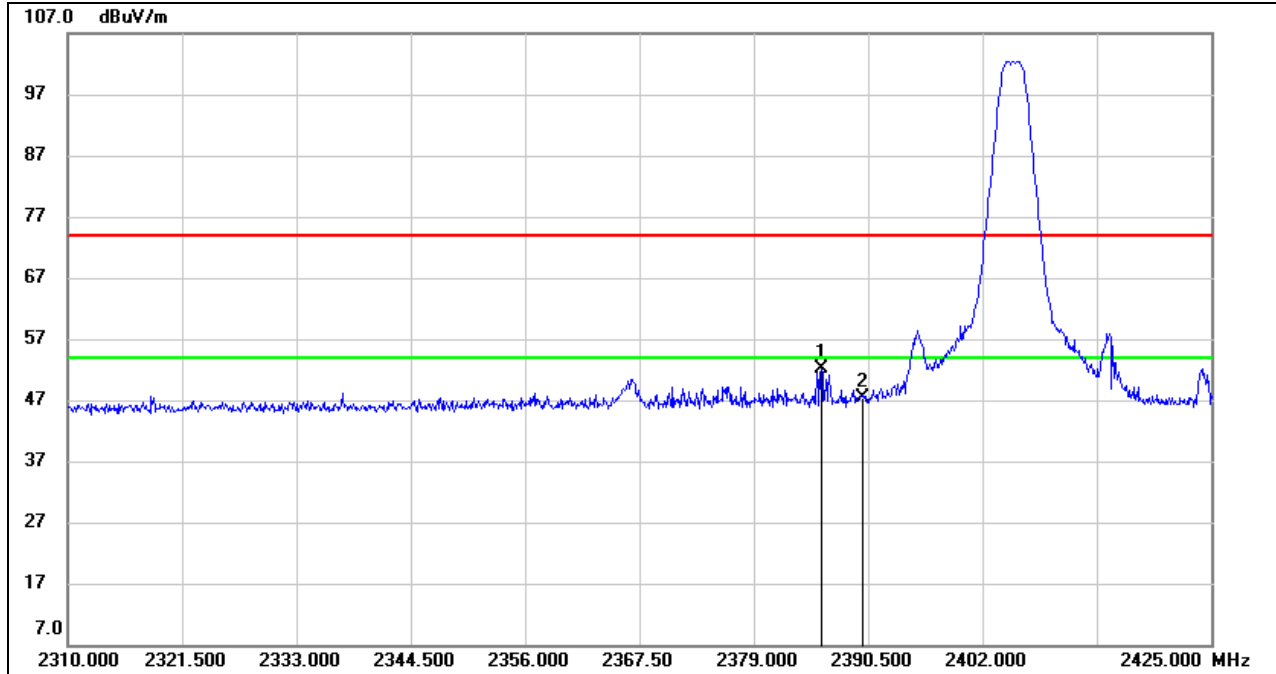

No.	Frequency (MHz)	Reading (dBuV)	Correct (dB/m)	Result (dBuV/m)	Limit (dBuV/m)	Margin (dB)	Remark
1	2385.785	18.87	33.32	52.19	74.00	-21.81	peak
2	2390.000	13.91	33.35	47.26	74.00	-26.74	peak

- Note: 1. Measurement = Reading Level + Correct Factor.  
 2. If Peak Result complies with AV limit, AV Result is deemed to comply with AV limit.  
 3. Peak: Peak detector.  
 4. Only the worst data was recorded, if it complies with the limit, the other emissions deemed to comply with the limit.

**AVG**

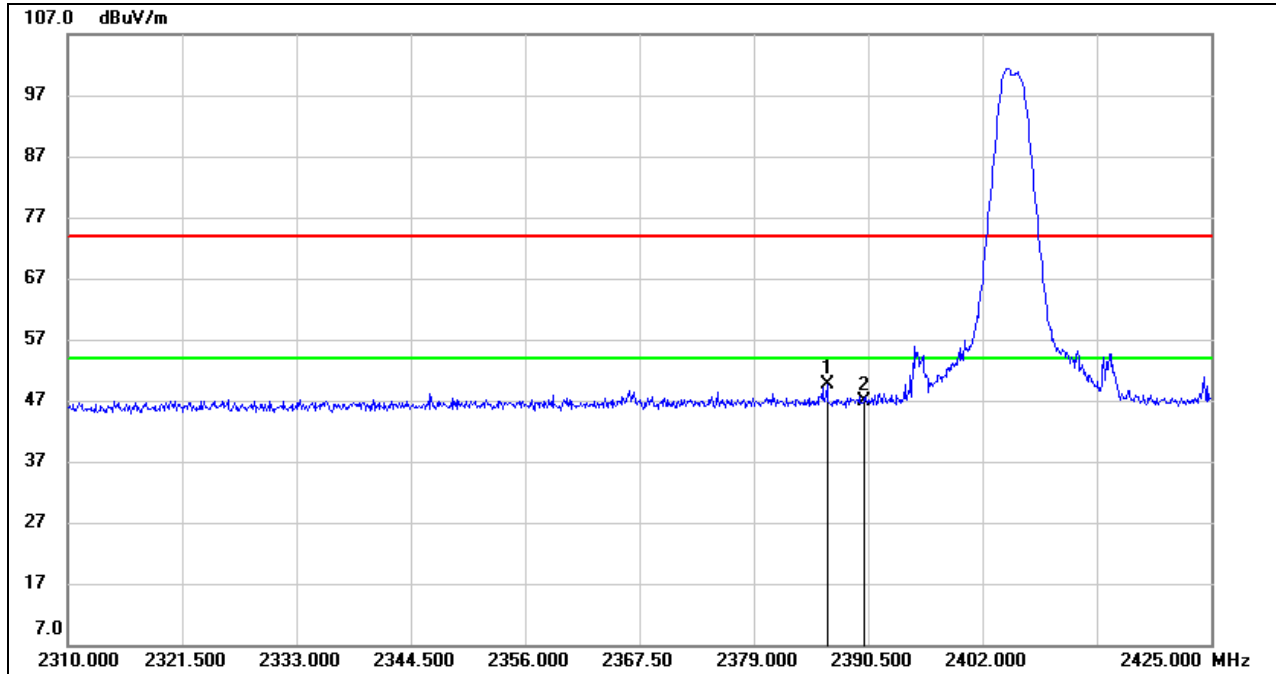

No.	Frequency (MHz)	Reading (dBuV)	Correct (dB/m)	Result (dBuV/m)	Limit (dBuV/m)	Margin (dB)	Remark
1	2386.360	16.38	33.33	49.71	54.00	-4.29	AVG
2	2390.000	13.56	33.35	46.91	54.00	-7.09	AVG

Note: 1. Measurement = Reading Level + Correct Factor.  
 2. AVG:  $VBW=1/Ton$ , where: Ton is the transmitting duration.  
 3. For the transmitting duration, please refer to clause 7.1.  
 4. Only the worst data was recorded, if it complies with the limit, the other emissions deemed to comply with the limit.

**RESTRICTED BANDEDGE (CHANNEL 11, VERTICAL)**

**PEAK**

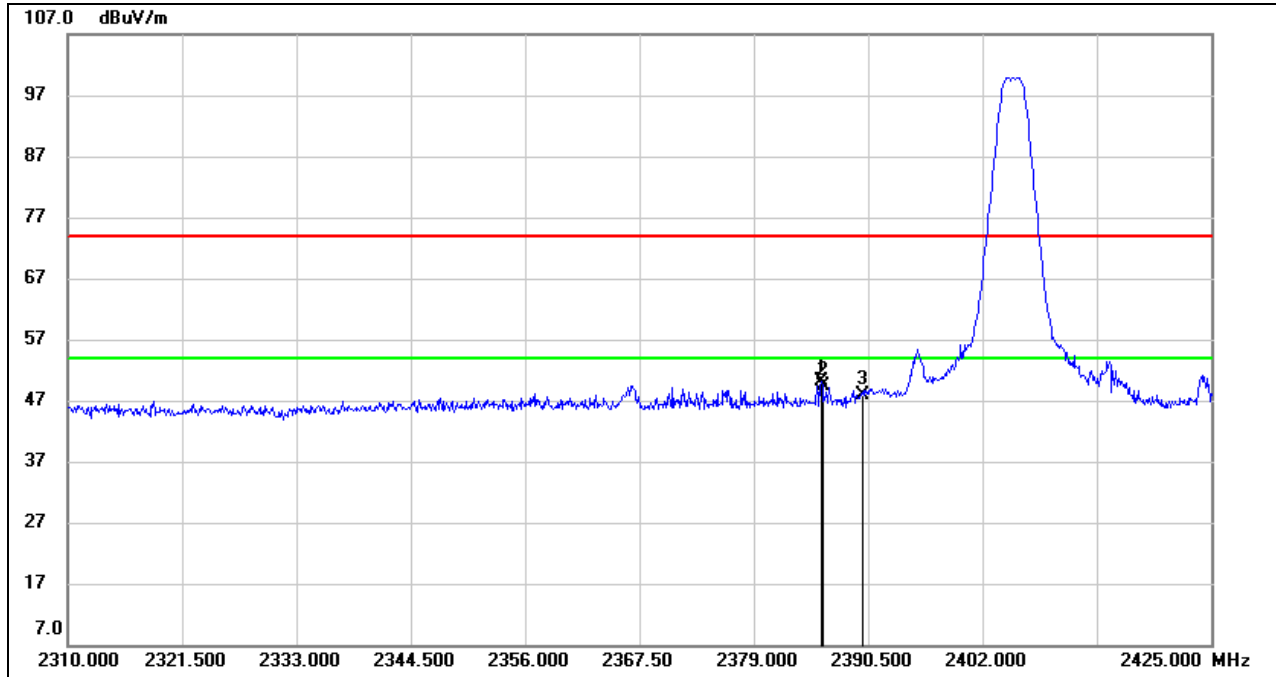

No.	Frequency (MHz)	Reading (dBuV)	Correct (dB/m)	Result (dBuV/m)	Limit (dBuV/m)	Margin (dB)	Remark
1	2385.785	16.87	33.32	50.19	74.00	-23.81	peak
2	2385.900	15.94	33.32	49.26	74.00	-24.74	peak
3	2390.000	14.41	33.35	47.76	74.00	-26.24	peak

- Note: 1. Measurement = Reading Level + Correct Factor.  
 2. If Peak Result complies with AV limit, AV Result is deemed to comply with AV limit.  
 3. Peak: Peak detector.  
 4. Only the worst data was recorded, if it complies with the limit, the other emissions deemed to comply with the limit.

**AVG**

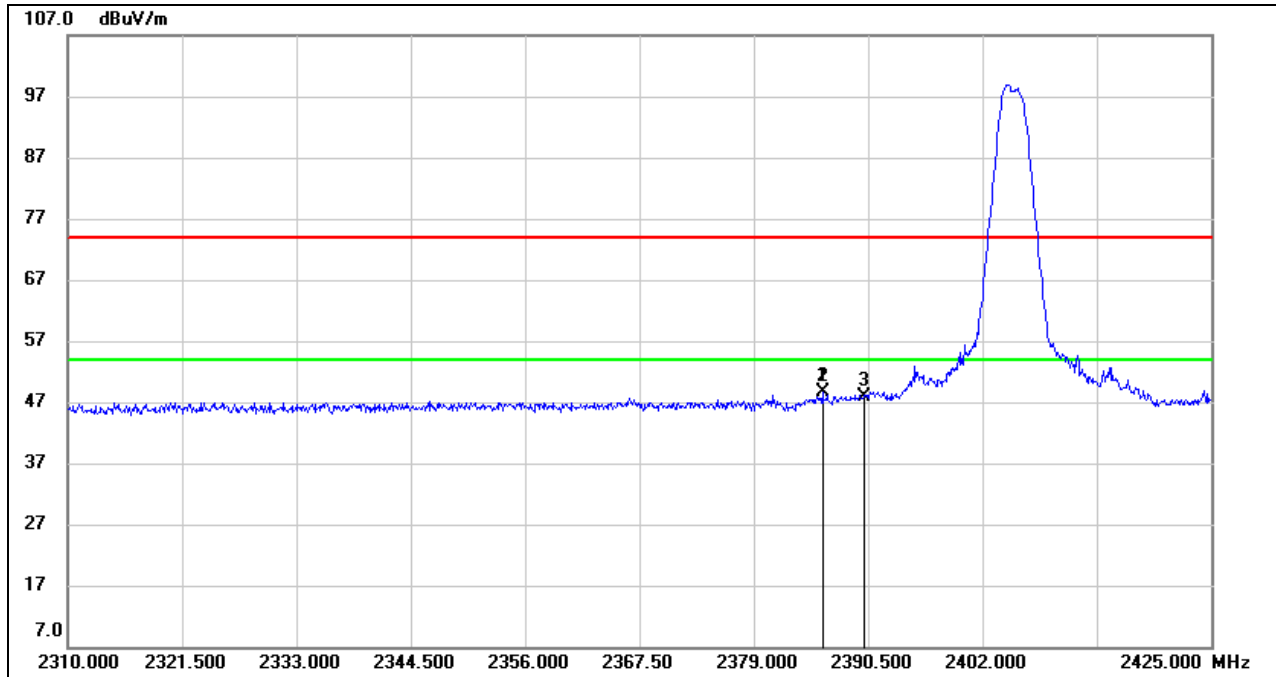

No.	Frequency (MHz)	Reading (dBuV)	Correct (dB/m)	Result (dBuV/m)	Limit (dBuV/m)	Margin (dB)	Remark
1	2385.785	15.36	33.32	48.68	54.00	-5.32	AVG
2	2385.900	15.36	33.32	48.68	54.00	-5.32	AVG
3	2390.000	14.56	33.35	47.91	54.00	-6.09	AVG

- Note: 1. Measurement = Reading Level + Correct Factor.  
 2. AVG:  $VBW=1/T_{on}$ , where:  $T_{on}$  is the transmitting duration.  
 3. For the transmitting duration, please refer to clause 7.1.  
 4. Only the worst data was recorded, if it complies with the limit, the other emissions deemed to comply with the limit.

**RESTRICTED BANDEDGE (CHANNEL 26, HORIZONTAL)**

**PEAK**

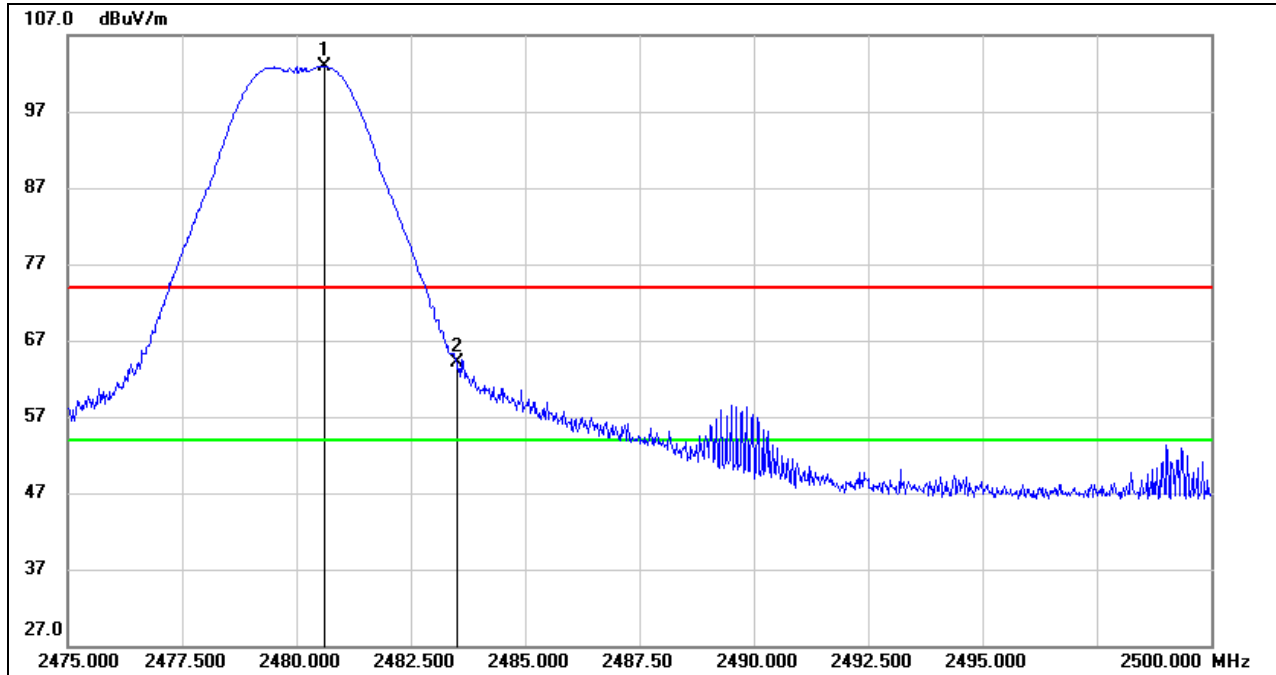

No.	Frequency (MHz)	Reading (dBuV)	Correct (dB/m)	Result (dBuV/m)	Limit (dBuV/m)	Margin (dB)	Remark
1	2480.625	69.20	33.70	102.90	/	/	fundamental
2	2483.500	30.44	33.71	64.15	74.00	-9.85	peak

Note: 1. Measurement = Reading Level + Correct Factor.

2. Peak: Peak detector.

3. Only the worst data was recorded, if it complies with the limit, the other emissions deemed to comply with the limit.



AVG

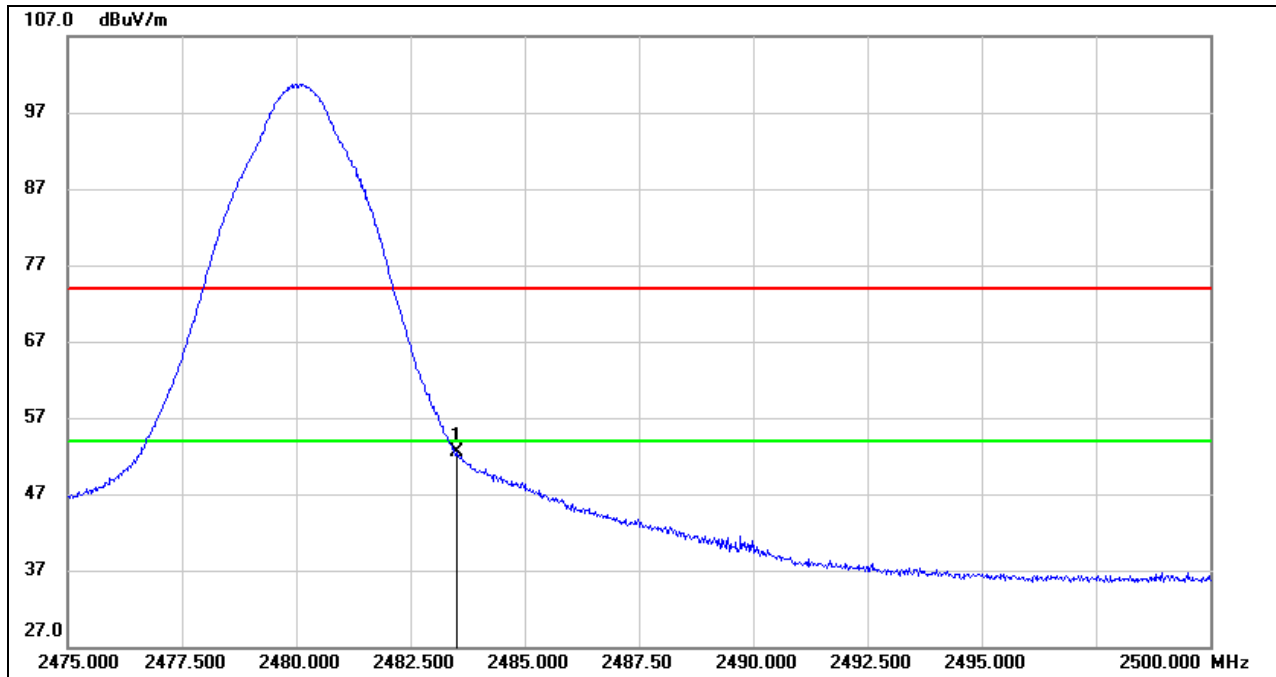

No.	Frequency (MHz)	Reading (dBuV)	Correct (dB/m)	Result (dBuV/m)	Limit (dBuV/m)	Margin (dB)	Remark
1	2483.500	18.71	33.71	52.42	54.00	-1.58	AVG

- Note: 1. Measurement = Reading Level + Correct Factor.  
 2. AVG:  $VBW=1/Ton$ , where: Ton is the transmitting duration.  
 3. For the transmitting duration, please refer to clause 7.1.  
 4. Only the worst data was recorded, if it complies with the limit, the other emissions deemed to comply with the limit.

**RESTRICTED BANDEDGE (CHANNEL 26, VERTICAL)**

**PEAK**

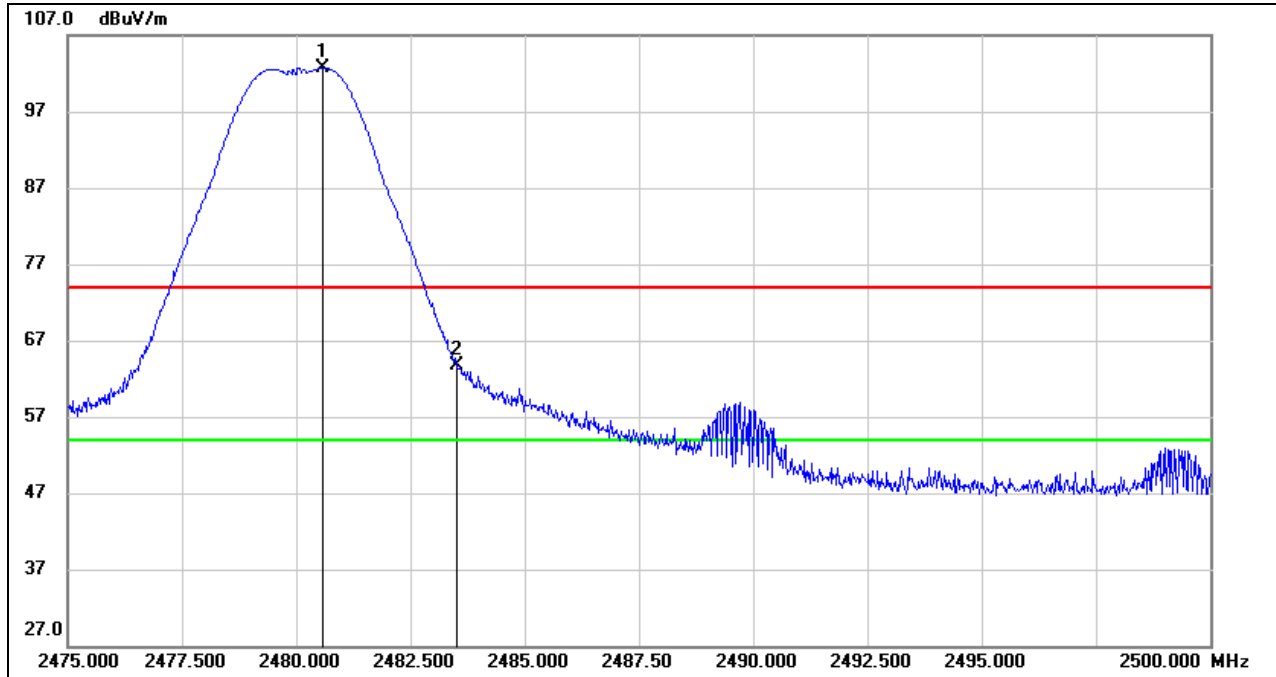

No.	Frequency (MHz)	Reading (dBuV)	Correct (dB/m)	Result (dBuV/m)	Limit (dBuV/m)	Margin (dB)	Remark
1	2480.575	69.02	33.69	102.71	/	/	fundamental
2	2483.500	30.08	33.71	63.79	74.00	-10.21	peak

Note: 1. Measurement = Reading Level + Correct Factor.  
 2. Peak: Peak detector.  
 3. Only the worst data was recorded, if it complies with the limit, the other emissions deemed to comply with the limit.

**AVG**

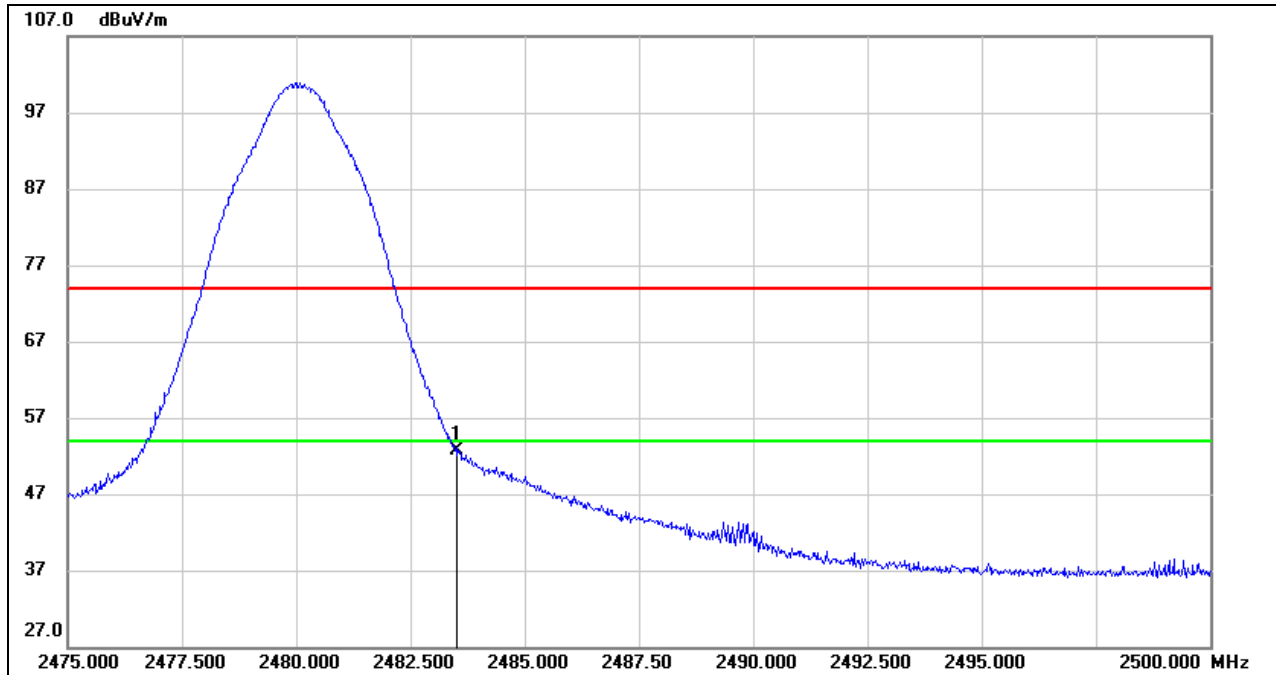

No.	Frequency (MHz)	Reading (dBuV)	Correct (dB/m)	Result (dBuV/m)	Limit (dBuV/m)	Margin (dB)	Remark
1	2483.500	19.09	33.71	52.80	54.00	-1.20	AVG

Note: 1. Measurement = Reading Level + Correct Factor.  
 2. AVG:  $VBW=1/Ton$ , where: Ton is the transmitting duration.  
 3. For the transmitting duration, please refer to clause 7.1.  
 4. Only the worst data was recorded, if it complies with the limit, the other emissions deemed to comply with the limit.

Note: All the channels have been tested, only the worst data was recorded in the report.

## 8.2. SPURIOUS EMISSIONS (1 GHz ~ 3 GHz)

### HARMONICS AND SPURIOUS EMISSIONS (CHANNEL 11, HORIZONTAL)

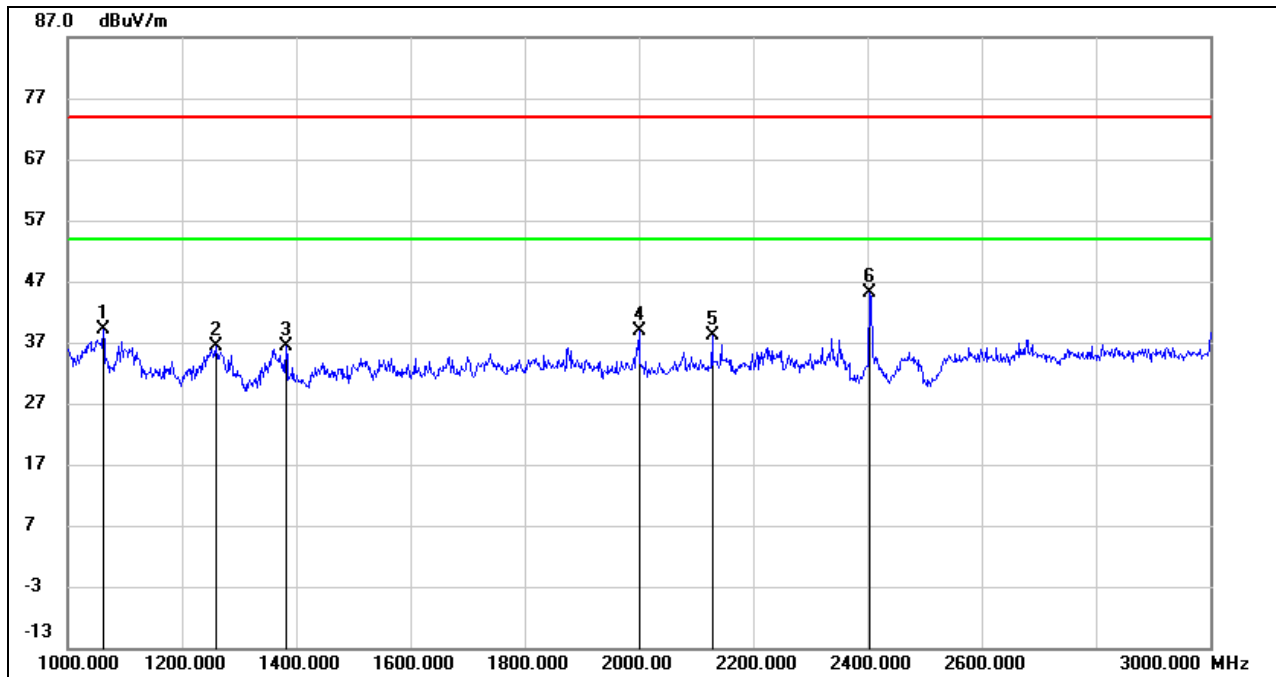

No.	Frequency (MHz)	Reading (dBuV)	Correct (dB/m)	Result (dBuV/m)	Limit (dBuV/m)	Margin (dB)	Remark
1	1062.000	52.90	-13.67	39.23	74.00	-34.77	peak
2	1260.000	49.34	-12.90	36.44	74.00	-37.56	peak
3	1382.000	49.04	-12.73	36.31	74.00	-37.69	peak
4	2000.000	49.06	-10.19	38.87	74.00	-35.13	peak
5	2128.000	47.57	-9.46	38.11	74.00	-35.89	peak
6	2405.000	53.40	-8.38	45.02	/	/	fundamental

- Note: 1. Peak Result = Reading Level + Correct Factor.  
 2. If Peak Result complies with AV limit, AV Result is deemed to comply with AV limit.  
 3. Peak: Peak detector.



**HARMONICS AND SPURIOUS EMISSIONS (CHANNEL 11, VERTICAL)**

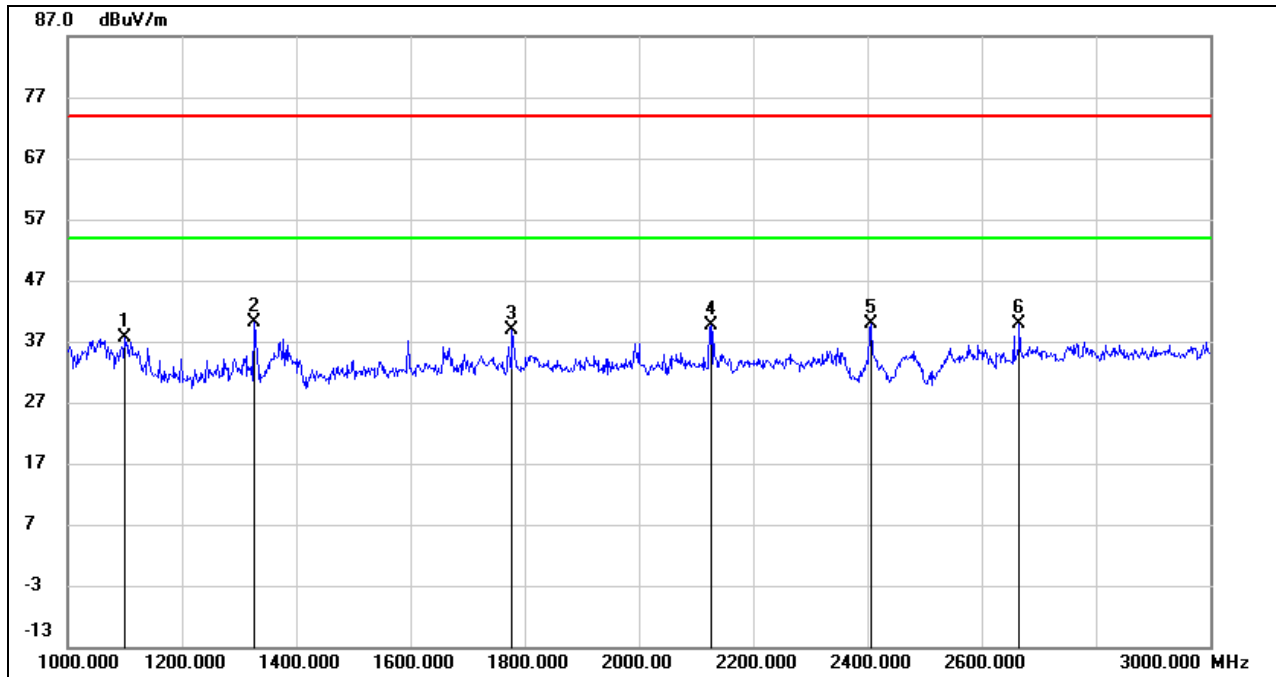

No.	Frequency (MHz)	Reading (dBuV)	Correct (dB/m)	Result (dBuV/m)	Limit (dBuV/m)	Margin (dB)	Remark
1	1100.000	51.19	-13.49	37.70	74.00	-36.30	peak
2	1326.000	52.90	-12.81	40.09	74.00	-33.91	peak
3	1778.000	49.02	-10.21	38.81	74.00	-35.19	peak
4	2126.000	49.03	-9.47	39.56	74.00	-34.44	peak
5	2405.000	48.14	-8.38	39.76	/	/	fundamental
6	2666.000	47.22	-7.43	39.79	74.00	-34.21	peak

- Note: 1. Peak Result = Reading Level + Correct Factor.  
 2. If Peak Result complies with AV limit, AV Result is deemed to comply with AV limit.  
 3. Peak: Peak detector.



**HARMONICS AND SPURIOUS EMISSIONS (CHANNEL 19, HORIZONTAL)**

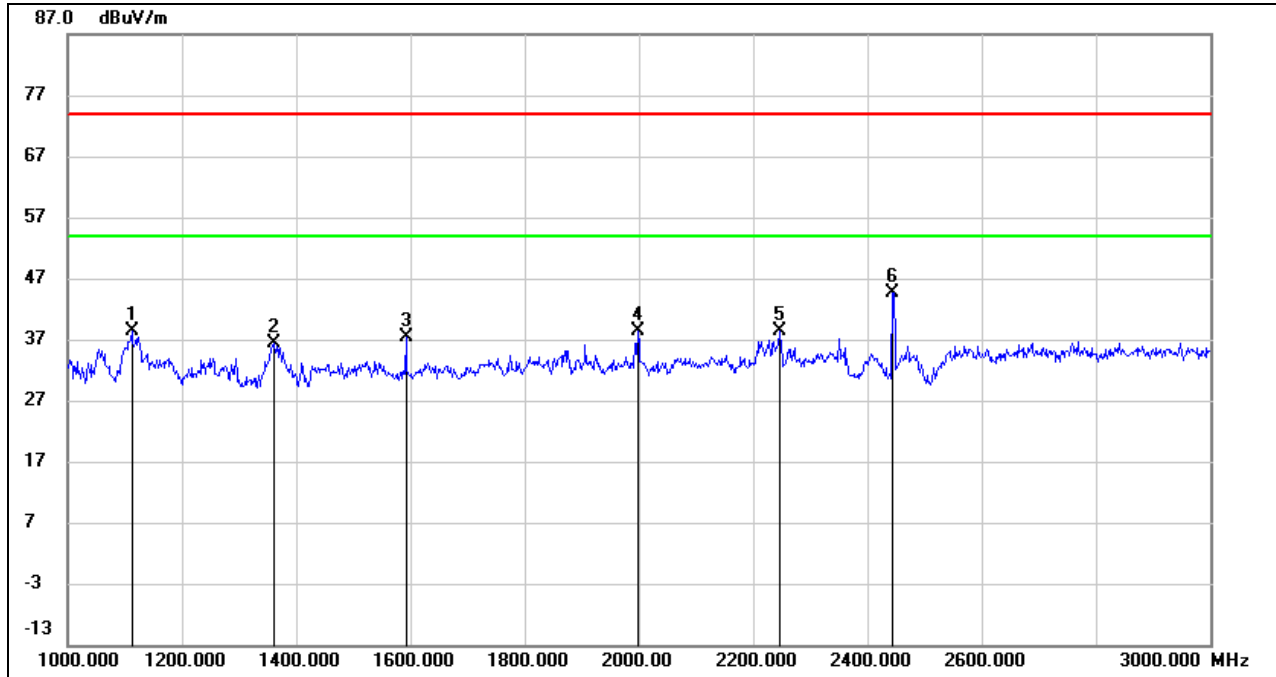

No.	Frequency (MHz)	Reading (dBuV)	Correct (dB/m)	Result (dBuV/m)	Limit (dBuV/m)	Margin (dB)	Remark
1	1112.000	51.70	-13.42	38.28	74.00	-35.72	peak
2	1362.000	49.06	-12.76	36.30	74.00	-37.70	peak
3	1592.000	49.09	-11.61	37.48	74.00	-36.52	peak
4	1998.000	48.54	-10.19	38.35	74.00	-35.65	peak
5	2246.000	47.22	-8.90	38.32	74.00	-35.68	peak
6	2445.000	52.98	-8.31	44.67	/	/	fundamental

Note: 1. Peak Result = Reading Level + Correct Factor.  
 2. If Peak Result complies with AV limit, AV Result is deemed to comply with AV limit.  
 3. Peak: Peak detector.



**HARMONICS AND SPURIOUS EMISSIONS (CHANNEL 19, VERTICAL)**

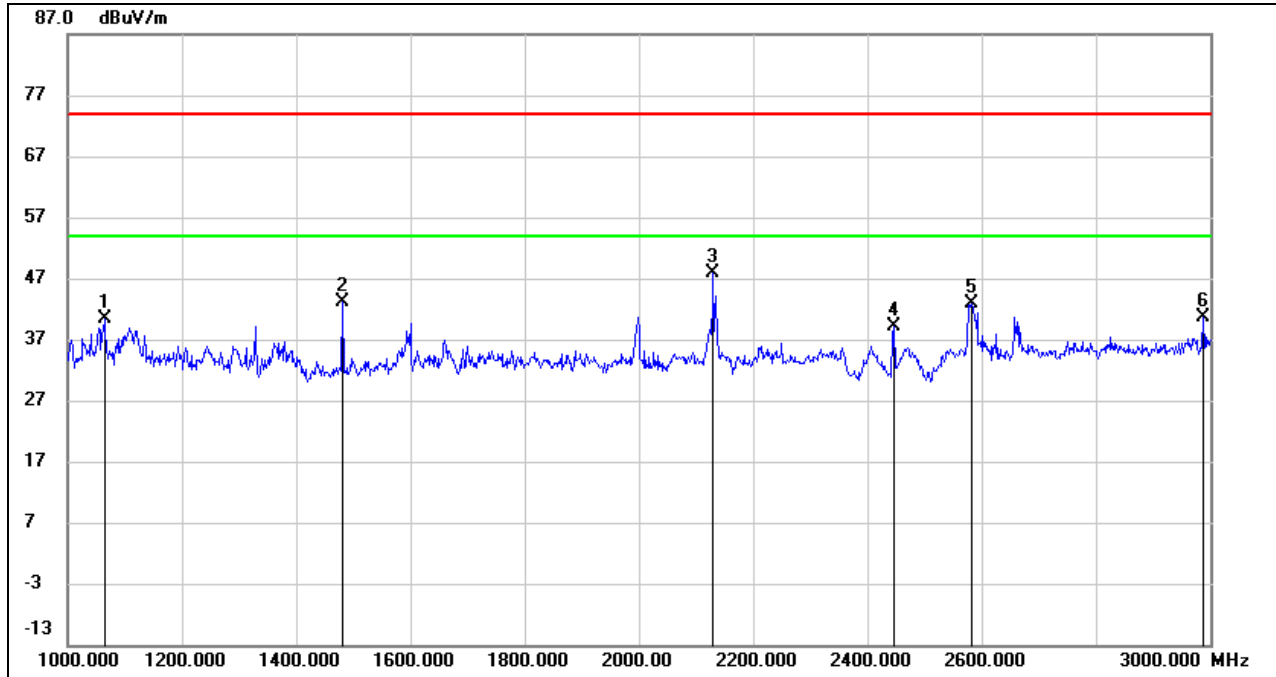

No.	Frequency (MHz)	Reading (dBuV)	Correct (dB/m)	Result (dBuV/m)	Limit (dBuV/m)	Margin (dB)	Remark
1	1064.000	54.07	-13.66	40.41	74.00	-33.59	peak
2	1480.000	55.40	-12.33	43.07	74.00	-30.93	peak
3	2130.000	57.23	-9.46	47.77	74.00	-26.23	peak
4	2445.000	47.41	-8.31	39.10	/	/	fundamental
5	2582.000	50.73	-7.92	42.81	74.00	-31.19	peak
6	2988.000	46.16	-5.64	40.52	74.00	-33.48	peak

Note: 1. Peak Result = Reading Level + Correct Factor.  
 2. If Peak Result complies with AV limit, AV Result is deemed to comply with AV limit.  
 3. Peak: Peak detector.

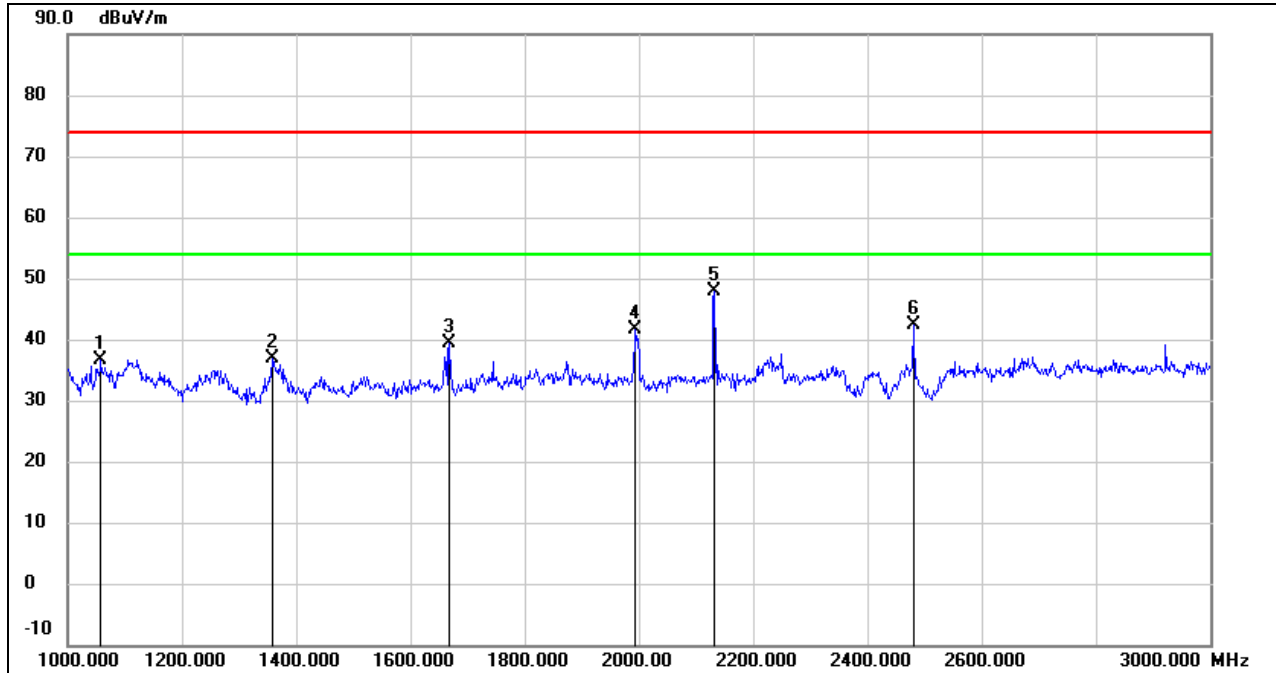
**HARMONICS AND SPURIOUS EMISSIONS (CHANNEL 26, HORIZONTAL)**

No.	Frequency (MHz)	Reading (dBuV)	Correct (dB/m)	Result (dBuV/m)	Limit (dBuV/m)	Margin (dB)	Remark
1	1058.000	50.44	-13.70	36.74	74.00	-37.26	peak
2	1358.000	49.55	-12.77	36.78	74.00	-37.22	peak
3	1668.000	50.51	-11.04	39.47	74.00	-34.53	peak
4	1994.000	51.71	-10.18	41.53	74.00	-32.47	peak
5	2132.000	57.42	-9.43	47.99	74.00	-26.01	peak
6	2480.000	50.71	-8.26	42.45	/	/	fundamental

- Note: 1. Peak Result = Reading Level + Correct Factor.  
 2. If Peak Result complies with AV limit, AV Result is deemed to comply with AV limit.  
 3. Peak: Peak detector.



**HARMONICS AND SPURIOUS EMISSIONS (CHANNEL 26, VERTICAL)**

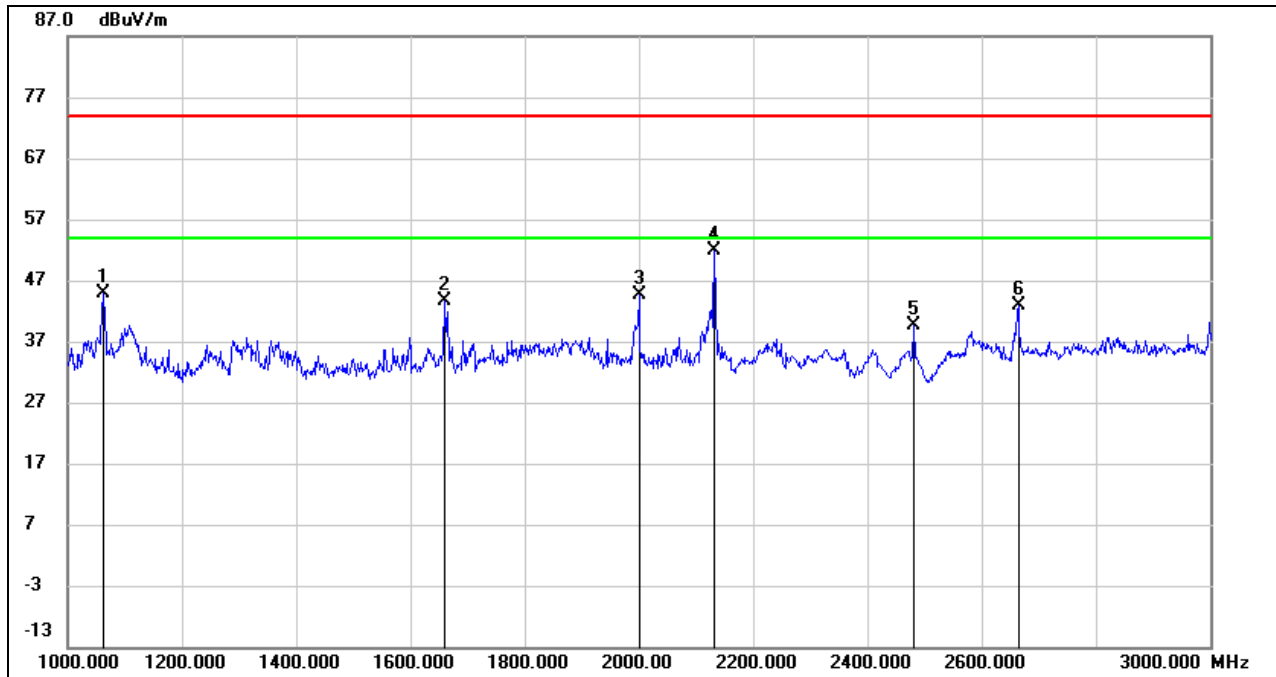

No.	Frequency (MHz)	Reading (dBuV)	Correct (dB/m)	Result (dBuV/m)	Limit (dBuV/m)	Margin (dB)	Remark
1	1062.000	58.62	-13.67	44.95	74.00	-29.05	peak
2	1660.000	54.73	-11.10	43.63	74.00	-30.37	peak
3	2000.000	54.75	-10.19	44.56	74.00	-29.44	peak
4	2132.000	61.31	-9.43	51.88	74.00	-22.12	peak
5	2480.000	47.88	-8.26	39.62	/	/	fundamental
6	2664.000	50.32	-7.44	42.88	74.00	-31.12	peak

Note: 1. Peak Result = Reading Level + Correct Factor.  
 2. If Peak Result complies with AV limit, AV Result is deemed to comply with AV limit.  
 3. Peak: Peak detector.

### 8.3. SPURIOUS EMISSIONS (3 GHz ~ 18 GHz)

#### HARMONICS AND SPURIOUS EMISSIONS (CHANNEL 11, HORIZONTAL)

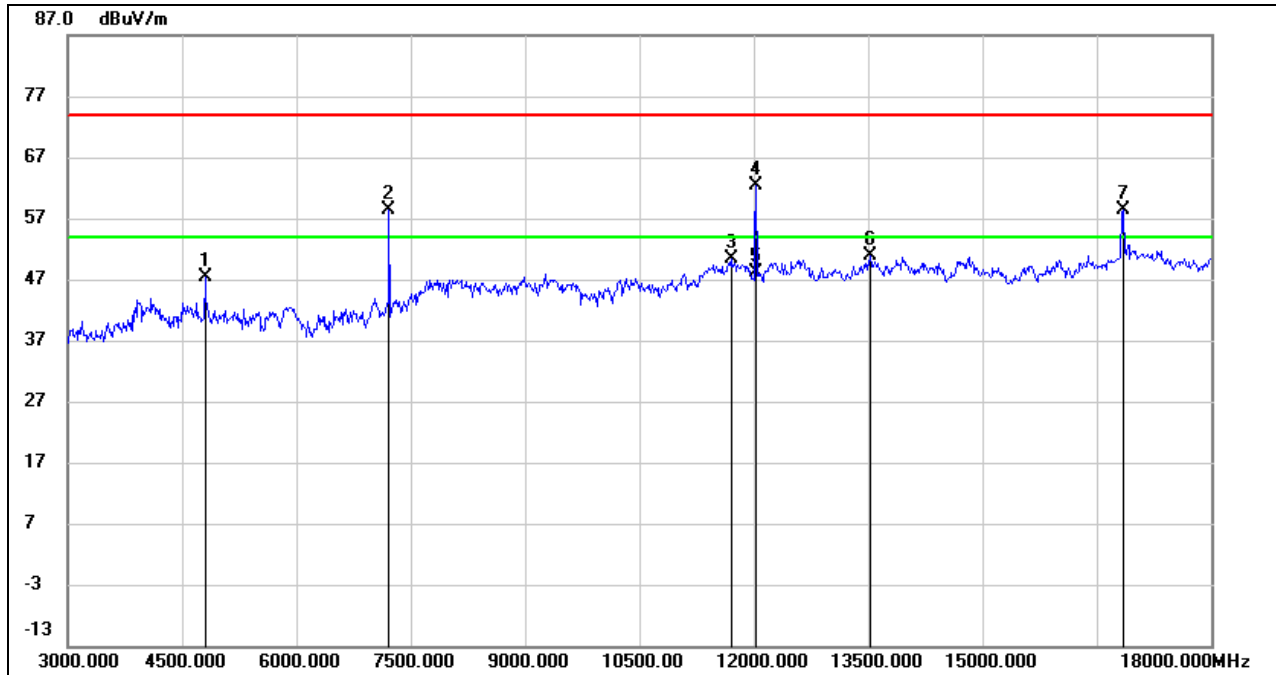

No.	Frequency (MHz)	Reading (dBuV)	Correct (dB/m)	Result (dBuV/m)	Limit (dBuV/m)	Margin (dB)	Remark
1	4800.000	45.98	1.40	47.38	74.00	-26.62	peak
2*	7215.000	50.98	7.32	58.30	/	/	peak
3	11700.000	35.04	15.35	50.39	74.00	-23.61	peak
4	12030.000	46.97	15.51	62.48	74.00	-11.52	peak
5	12030.000	32.70	15.51	48.21	54.00	-5.79	AVG
6	13530.000	33.66	17.19	50.85	74.00	-23.15	peak
7*	16845.000	37.22	21.10	58.32	/	/	peak

Note: 1. Peak Result = Reading Level + Correct Factor.

2. If Peak Result complies with AV limit, AV Result is deemed to comply with AV limit.

3. Peak: Peak detector.

4. Filter losses were only considered in the spurious frequency bands and the authorized band was not corrected for High Pass Filter losses.

5. Proper operation of the transmitter prior to adding the filter to the measurement chain.

6. \*-indicates frequency out of 47CFR Pt 15 / ISSED RSS-Restricted band.

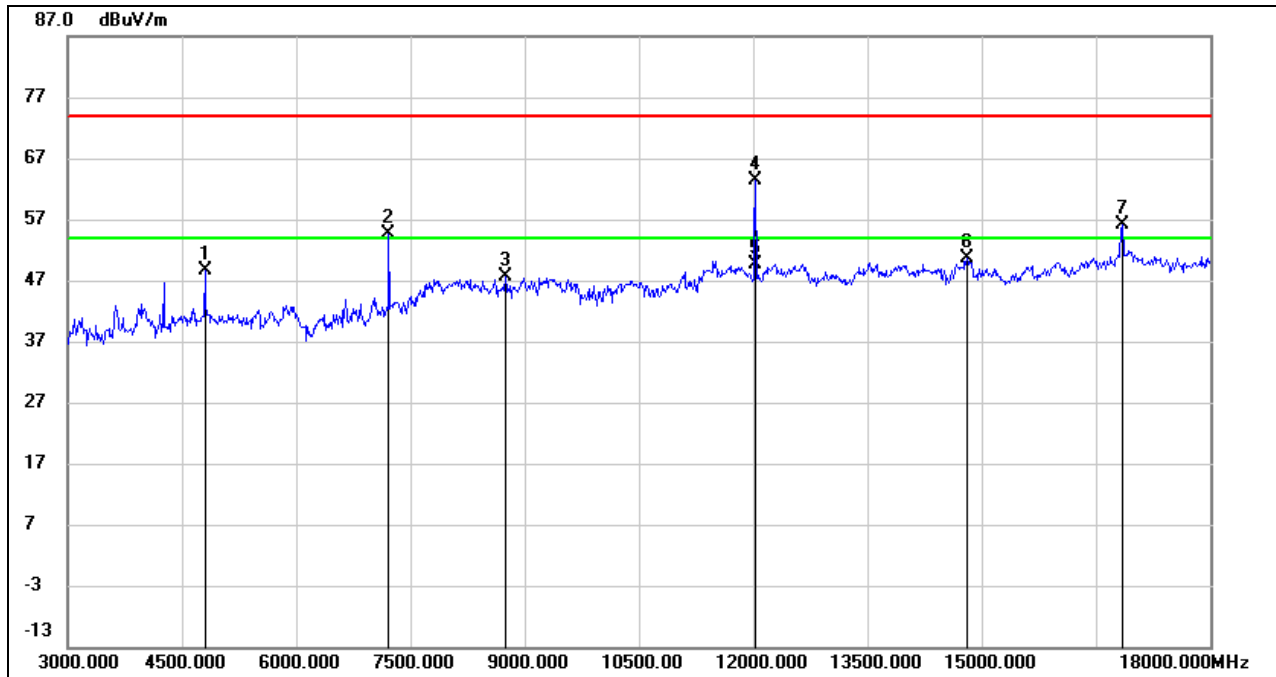
**HARMONICS AND SPURIOUS EMISSIONS (CHANNEL 11, VERTICAL)**

No.	Frequency (MHz)	Reading (dBuV)	Correct (dB/m)	Result (dBuV/m)	Limit (dBuV/m)	Margin (dB)	Remark
1	4800.000	47.14	1.40	48.54	74.00	-25.46	peak
2*	7215.000	47.20	7.32	54.52	/	/	peak
3	8745.000	38.53	9.13	47.66	74.00	-26.34	peak
4	12030.000	47.80	15.51	63.31	74.00	-10.69	peak
5	12030.000	34.20	15.51	49.71	54.00	-4.29	AVG
6	14805.000	32.72	18.00	50.72	74.00	-23.28	peak
7*	16845.000	35.13	21.10	56.23	/	/	peak

Note: 1. Peak Result = Reading Level + Correct Factor.

2. If Peak Result complies with AV limit, AV Result is deemed to comply with AV limit.

3. Peak: Peak detector.

4. AVG:  $VBW=1/Ton$ , where: Ton is the transmitting duration.

5. For the transmitting duration, please refer to clause 7.1.

6. Filter losses were only considered in the spurious frequency bands and the authorized band was not corrected for High Pass Filter losses.

7. Proper operation of the transmitter prior to adding the filter to the measurement chain.

8. \*-indicates frequency out of 47CFR Pt 15 / ISED RSS-Restricted band.

**HARMONICS AND SPURIOUS EMISSIONS (CHANNEL 19, HORIZONTAL)**

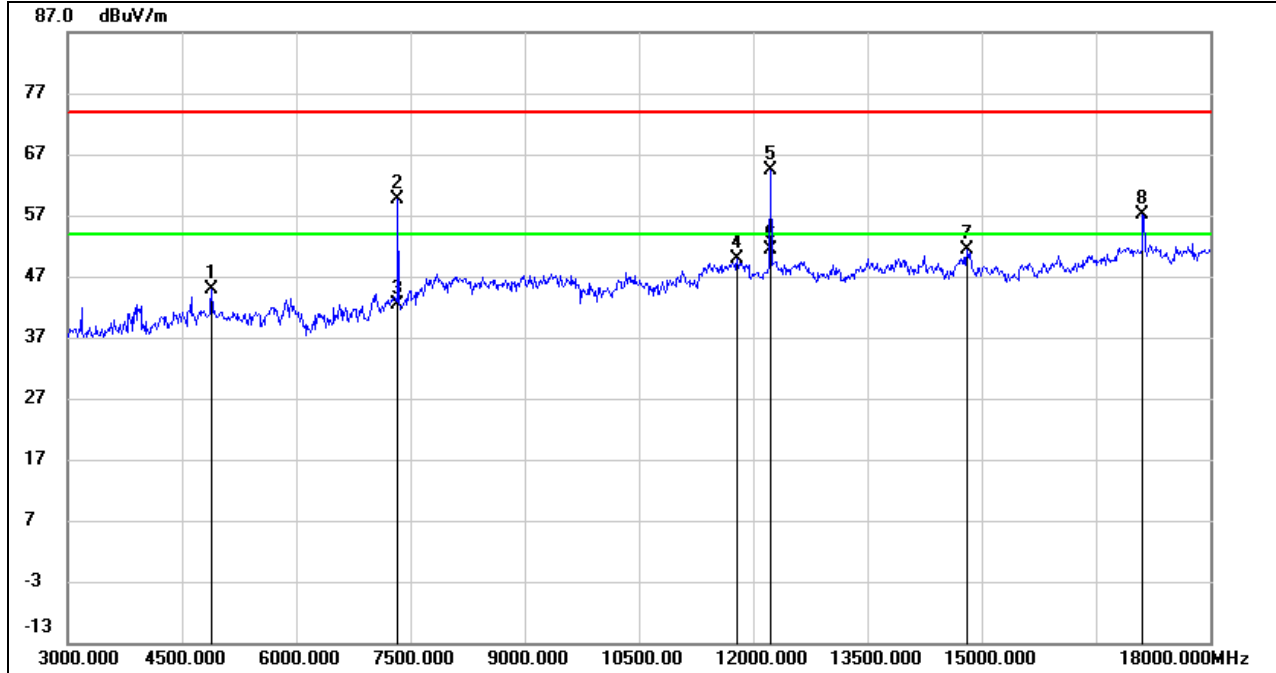

No.	Frequency (MHz)	Reading (dBuV)	Correct (dB/m)	Result (dBuV/m)	Limit (dBuV/m)	Margin (dB)	Remark
1	4890.000	43.64	1.30	44.94	74.00	-29.06	peak
2	7335.000	52.11	7.41	59.52	74.00	-14.48	peak
3	7335.000	34.90	7.41	42.31	54.00	-11.69	AVG
4	11790.000	34.50	15.26	49.76	74.00	-24.24	peak
5	12225.000	48.42	15.99	64.41	74.00	-9.59	peak
6	12225.000	35.31	15.99	51.30	54.00	-2.70	AVG
7	14805.000	33.28	18.00	51.28	74.00	-22.72	peak
8*	17115.000	35.12	21.91	57.03	/	/	peak

- Note: 1. Peak Result = Reading Level + Correct Factor.  
 2. If Peak Result complies with AV limit, AV Result is deemed to comply with AV limit.  
 3. Peak: Peak detector.  
 4. Filter losses were only considered in the spurious frequency bands and the authorized band was not corrected for High Pass Filter losses.  
 5. Proper operation of the transmitter prior to adding the filter to the measurement chain.  
 6. \*-indicates frequency out of 47CFR Pt 15 / ISED RSS-Restricted band.

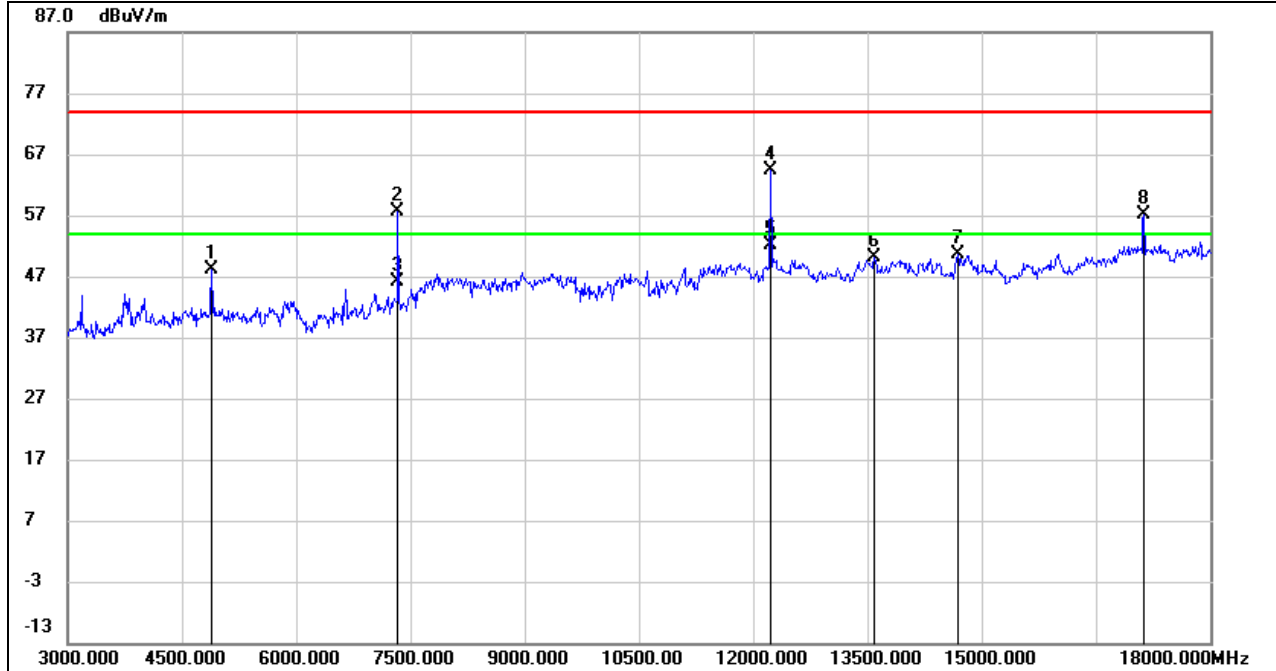
**HARMONICS AND SPURIOUS EMISSIONS (CHANNEL 19, VERTICAL)**

No.	Frequency (MHz)	Reading (dBuV)	Correct (dB/m)	Result (dBuV/m)	Limit (dBuV/m)	Margin (dB)	Remark
1	4890.000	46.86	1.30	48.16	74.00	-25.84	peak
2	7335.000	50.29	7.41	57.70	74.00	-16.30	peak
3	7335.000	38.80	7.41	46.21	54.00	-7.79	AVG
4	12225.000	48.37	15.99	64.36	74.00	-9.64	peak
5	12225.000	36.21	15.99	52.20	54.00	-1.80	AVG
6	13590.000	32.92	17.11	50.03	74.00	-23.97	peak
7	14685.000	33.04	17.64	50.68	74.00	-23.32	peak
8*	17130.000	35.09	21.92	57.01	/	/	peak

Note: 1. Peak Result = Reading Level + Correct Factor.

2. If Peak Result complies with AV limit, AV Result is deemed to comply with AV limit.

3. Peak: Peak detector.

4. Filter losses were only considered in the spurious frequency bands and the authorized band was not corrected for High Pass Filter losses.

5. Proper operation of the transmitter prior to adding the filter to the measurement chain.

6. \*-indicates frequency out of 47CFR Pt 15 / ISED RSS-Restricted band.

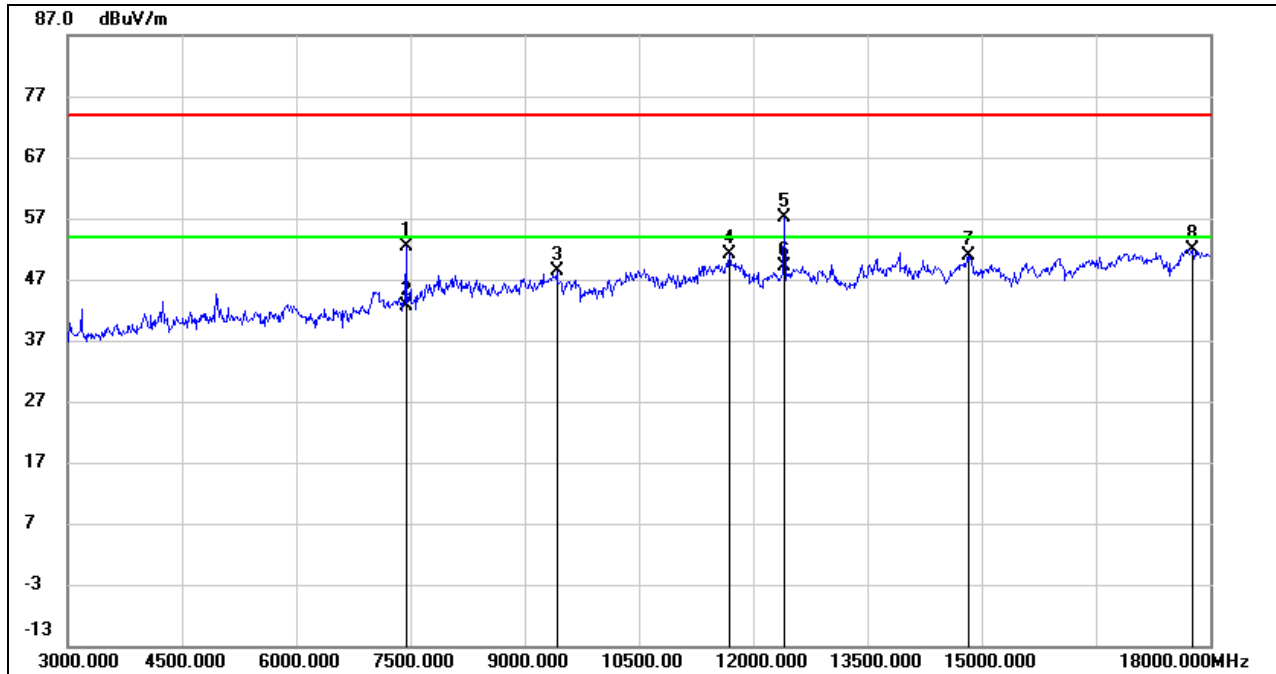
**HARMONICS AND SPURIOUS EMISSIONS (CHANNEL 26, HORIZONTAL)**

No.	Frequency (MHz)	Reading (dBuV)	Correct (dB/m)	Result (dBuV/m)	Limit (dBuV/m)	Margin (dB)	Remark
1	7440.000	44.33	8.13	52.46	74.00	-21.54	peak
2	7440.000	34.62	8.13	42.75	54.00	-11.25	AVG
3	9420.000	37.42	10.88	48.30	74.00	-25.70	peak
4	11685.000	35.84	15.26	51.10	74.00	-22.90	peak
5	12405.000	41.21	15.94	57.15	74.00	-16.85	peak
6	12405.000	33.31	15.94	49.25	54.00	-4.75	AVG
7	14820.000	33.02	17.91	50.93	74.00	-23.07	peak
8	17760.000	28.05	23.82	51.87	74.00	-22.13	peak

Note: 1. Peak Result = Reading Level + Correct Factor.

2. If Peak Result complies with AV limit, AV Result is deemed to comply with AV limit.

3. Peak: Peak detector.

4. AVG:  $VBW=1/Ton$ , where: Ton is the transmitting duration.

5. For the transmitting duration, please refer to clause 7.1.

6. Filter losses were only considered in the spurious frequency bands and the authorized band was not corrected for High Pass Filter losses.

7. Proper operation of the transmitter prior to adding the filter to the measurement chain.

8. \*-indicates frequency out of 47CFR Pt 15 / ISED RSS-Restricted band.

**HARMONICS AND SPURIOUS EMISSIONS (CHANNEL 26, VERTICAL)**

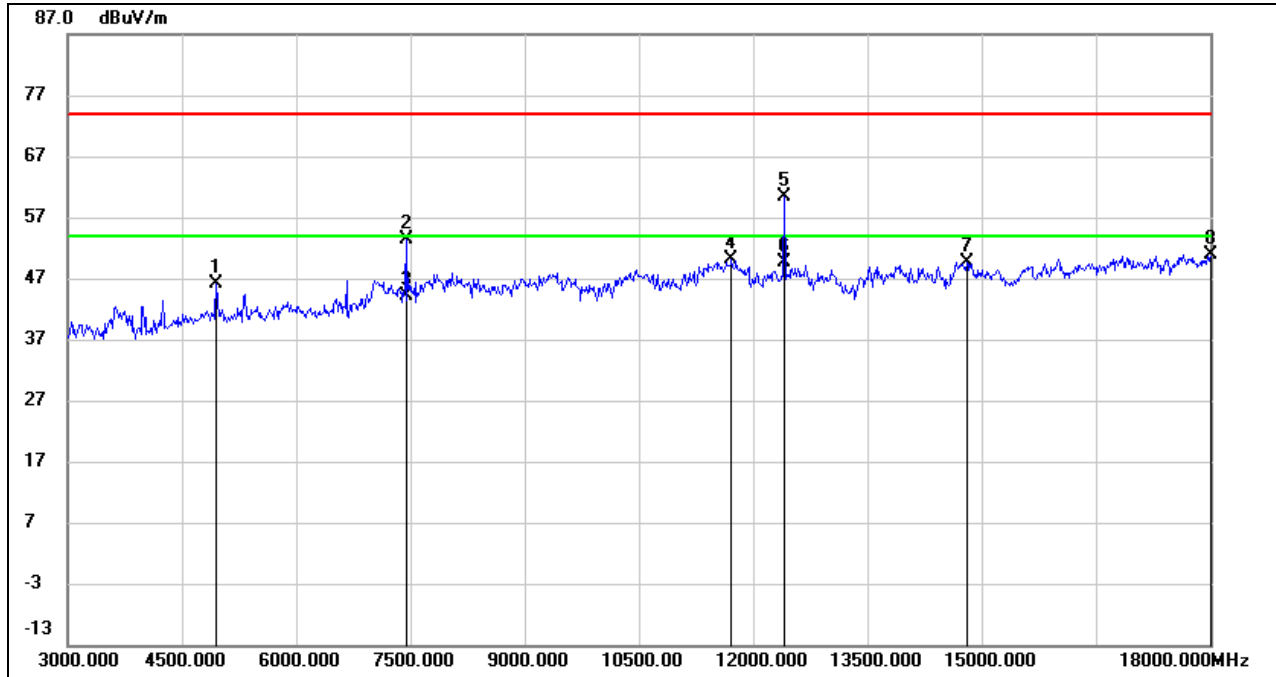

No.	Frequency (MHz)	Reading (dBuV)	Correct (dB/m)	Result (dBuV/m)	Limit (dBuV/m)	Margin (dB)	Remark
1	4950.000	44.39	1.71	46.10	74.00	-27.90	peak
2	7440.000	45.33	8.13	53.46	74.00	-20.54	peak
3	7440.000	35.88	8.13	44.01	54.00	-9.99	AVG
4	11715.000	34.67	15.34	50.01	74.00	-23.99	peak
5	12405.000	44.54	15.94	60.48	74.00	-13.52	peak
6	12405.000	33.73	15.94	49.67	54.00	-4.33	AVG
7	14805.000	31.71	18.00	49.71	74.00	-24.29	peak
8	18000.000	26.57	24.27	50.84	74.00	-23.16	peak

- Note: 1. Peak Result = Reading Level + Correct Factor.  
 2. If Peak Result complies with AV limit, AV Result is deemed to comply with AV limit.  
 3. Peak: Peak detector.  
 4. AVG:  $VBW=1/Ton$ , where: Ton is the transmitting duration.  
 5. For the transmitting duration, please refer to clause 7.1.  
 6. Filter losses were only considered in the spurious frequency bands and the authorized band was not corrected for High Pass Filter losses.  
 7. Proper operation of the transmitter prior to adding the filter to the measurement chain.  
 8. \*-indicates frequency out of 47CFR Pt 15 / ISED RSS-Restricted band.

### 8.4. SPURIOUS EMISSIONS (18 GHz ~ 26 GHz)

#### SPURIOUS EMISSIONS (CHANNEL 11, WORST-CASE CONFIGURATION, HORIZONTAL)

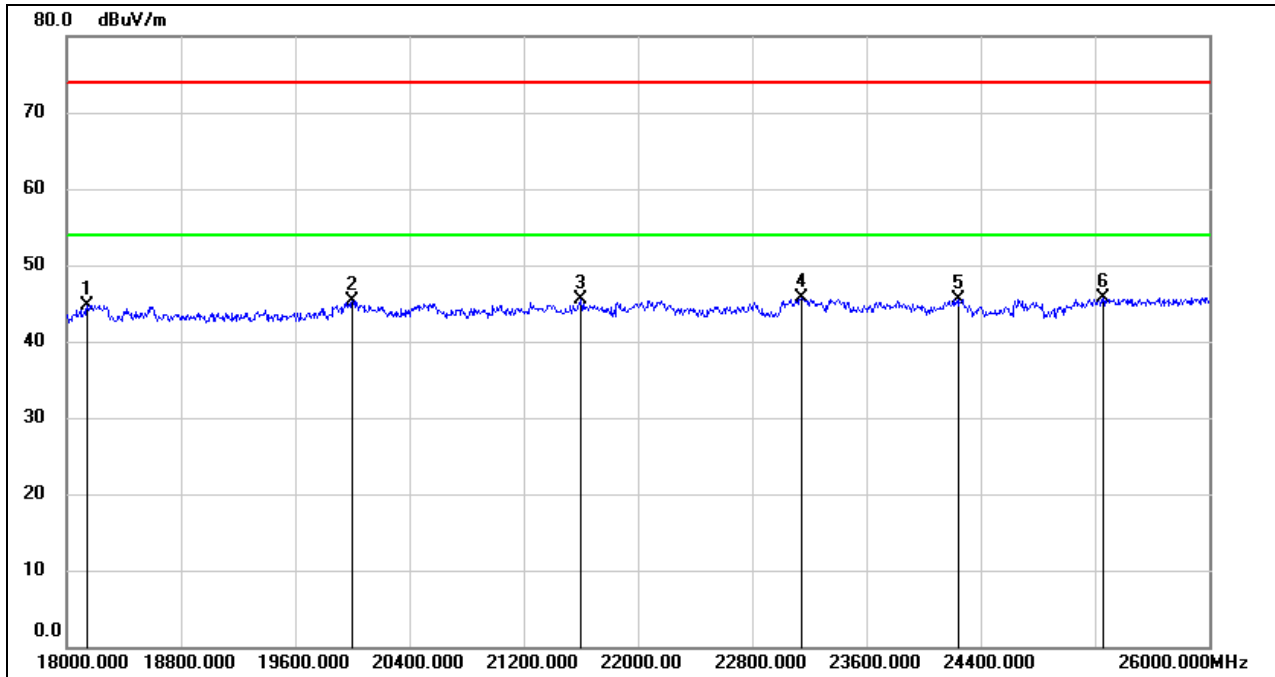

No.	Frequency (MHz)	Reading (dBuV)	Correct (dB/m)	Result (dBuV/m)	Limit (dBuV/m)	Margin (dB)	Remark
1	18144.000	50.27	-5.48	44.79	74.00	-29.21	peak
2	20000.000	50.81	-5.45	45.36	74.00	-28.64	peak
3	21600.000	50.02	-4.54	45.48	74.00	-28.52	peak
4	23144.000	49.05	-3.40	45.65	74.00	-28.35	peak
5	24248.000	48.32	-2.83	45.49	74.00	-28.51	peak
6	25256.000	47.29	-1.67	45.62	74.00	-28.38	peak

- Note: 1. Peak Result = Reading Level + Correct Factor.  
 2. If Peak Result complies with AV limit, AV Result is deemed to comply with AV limit.  
 3. Peak: Peak detector.





**SPURIOUS EMISSIONS (CHANNEL 11, WORST-CASE CONFIGURATION, VERTICAL)**

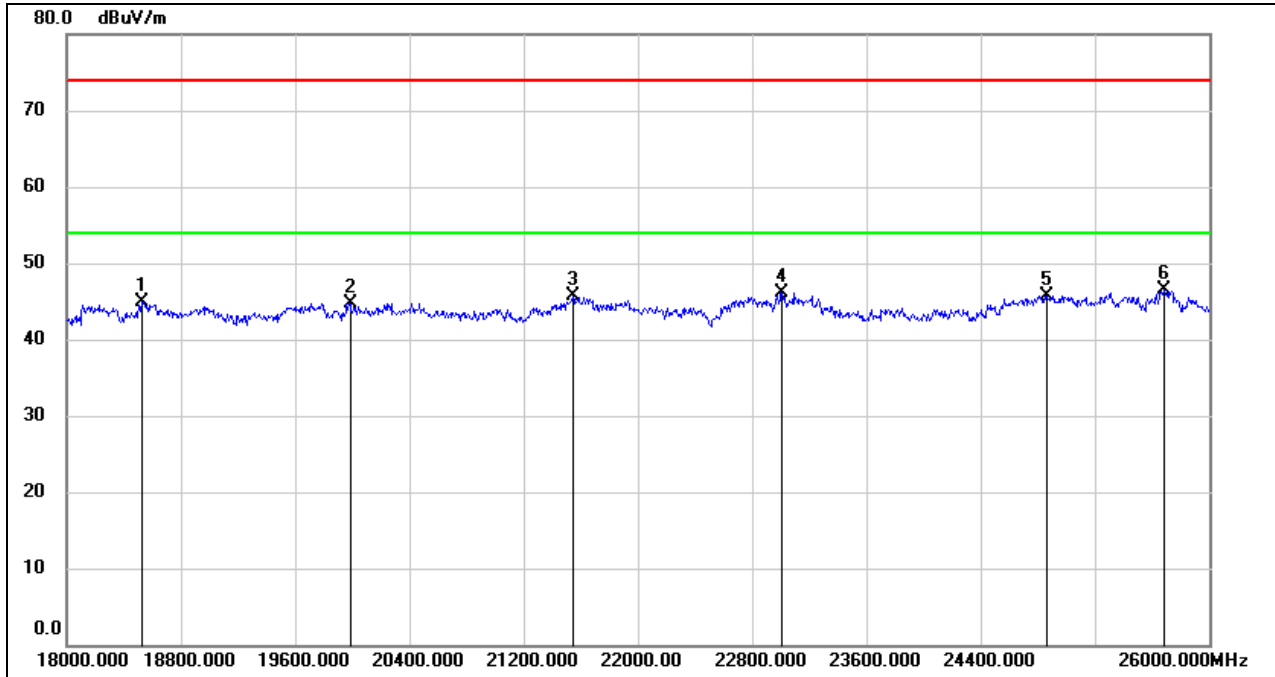

No.	Frequency (MHz)	Reading (dBuV)	Correct (dB/m)	Result (dBuV/m)	Limit (dBuV/m)	Margin (dB)	Remark
1	18528.000	50.11	-5.26	44.85	74.00	-29.15	peak
2	19984.000	50.21	-5.44	44.77	74.00	-29.23	peak
3	21544.000	50.26	-4.63	45.63	74.00	-28.37	peak
4	23008.000	49.60	-3.44	46.16	74.00	-27.84	peak
5	24864.000	48.03	-2.23	45.80	74.00	-28.20	peak
6	25688.000	47.31	-0.90	46.41	74.00	-27.59	peak

- Note: 1. Peak Result = Reading Level + Correct Factor.  
 2. If Peak Result complies with AV limit, AV Result is deemed to comply with AV limit.  
 3. Peak: Peak detector.

Note: All the channels have been tested, only the worst data was recorded in the report.

### 8.5. SPURIOUS EMISSIONS (30 MHz ~ 1 GHz)

#### SPURIOUS EMISSIONS (CHANNEL 11, WORST-CASE CONFIGURATION, HORIZONTAL)

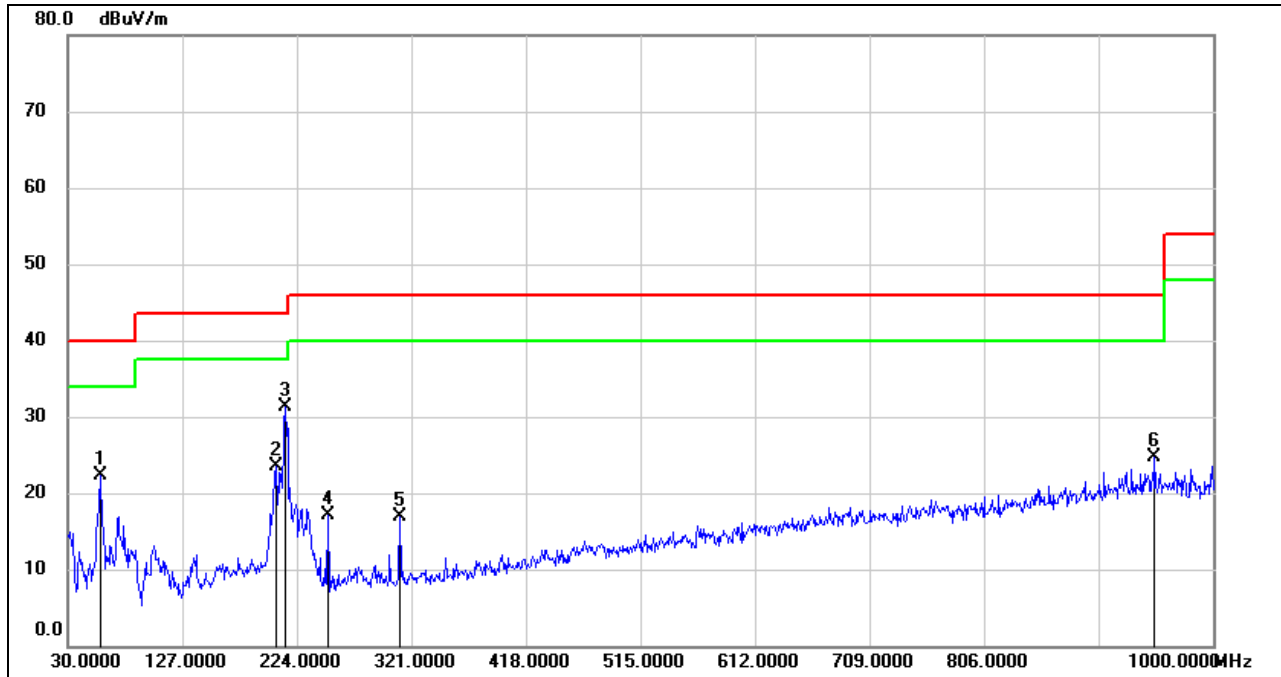

No.	Frequency (MHz)	Reading (dBuV)	Correct (dB/m)	Result (dBuV/m)	Limit (dBuV/m)	Margin (dB)	Remark
1	57.1600	42.87	-20.58	22.29	40.00	-17.71	QP
2	206.5399	40.56	-16.97	23.59	43.50	-19.91	QP
3	214.3000	48.91	-17.66	31.25	43.50	-12.25	QP
4	250.1900	36.03	-18.91	17.12	46.00	-28.88	QP
5	311.3000	31.90	-15.04	16.86	46.00	-29.14	QP
6	950.5300	29.16	-4.42	24.74	46.00	-21.26	QP

- Note: 1. Result Level = Read Level + Correct Factor.  
 2. If Peak Result complies with QP limit, QP Result is deemed to comply with QP limit.  
 3. Test setup: RBW: 120 kHz, VBW: 300 kHz, Sweep time: auto.

**SPURIOUS EMISSIONS (CHANNEL 11, WORST-CASE CONFIGURATION, VERTICAL)**

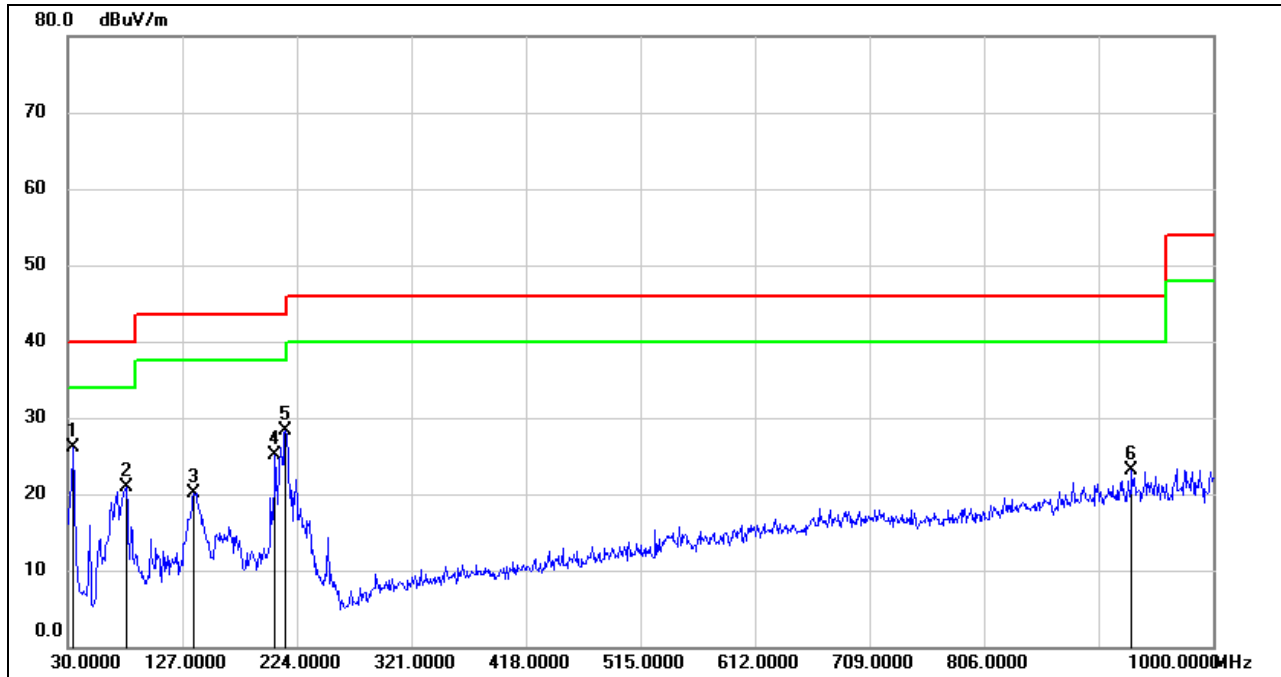

No.	Frequency (MHz)	Reading (dBuV)	Correct (dB/m)	Result (dBuV/m)	Limit (dBuV/m)	Margin (dB)	Remark
1	34.8500	45.53	-19.40	26.13	40.00	-13.87	QP
2	79.4700	42.21	-21.30	20.91	40.00	-19.09	QP
3	136.7000	39.20	-19.02	20.18	43.50	-23.32	QP
4	205.5700	42.07	-16.88	25.19	43.50	-18.31	QP
5	214.3000	45.87	-17.66	28.21	43.50	-15.29	QP
6	931.1300	27.93	-4.76	23.17	46.00	-22.83	QP

- Note: 1. Result Level = Read Level + Correct Factor.  
 2. If Peak Result complies with QP limit, QP Result is deemed to comply with QP limit.  
 3. Test setup: RBW: 120 kHz, VBW: 300 kHz, Sweep time: auto

Note: All the channels have been tested, only the worst data was recorded in the report.

### 8.6. SPURIOUS EMISSIONS BELOW 30 MHz

**SPURIOUS EMISSIONS (CHANNEL 11, LOOP ANTENNA FACE ON TO THE EUT, WORST-CASE CONFIGURATION)**

9 kHz~ 150 kHz

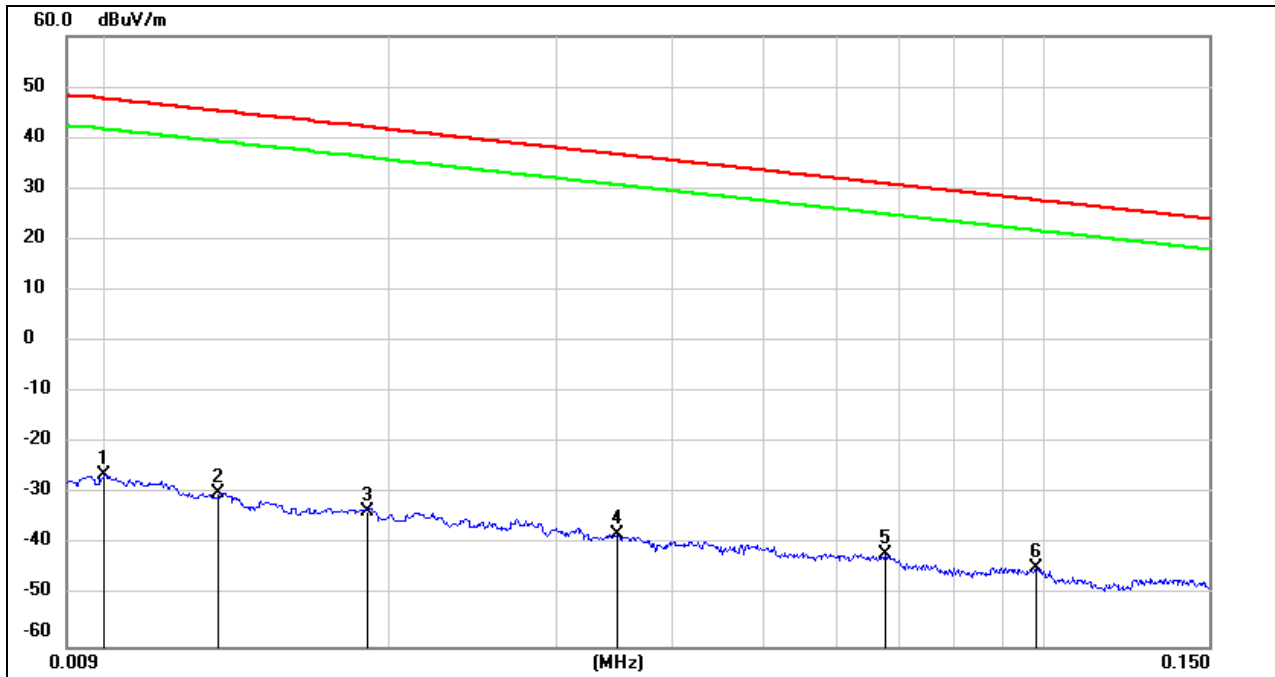

No.	Frequency (MHz)	Reading (dBuV)	Correct (dB/m)	FCC Result (dBuV/m)	FCC Limit (dBuV/m)	ISED Result (dBuA/m)	ISED Limit (dBuA/m)	Margin (dB)	Remark
1	0.0100	75.22	-101.40	-26.18	47.6	-77.68	-3.90	-73.78	peak
2	0.0131	71.47	-101.38	-29.91	45.25	-81.41	-6.25	-75.16	peak
3	0.0189	67.99	-101.35	-33.36	42.07	-84.86	-9.43	-75.43	peak
4	0.0349	63.53	-101.41	-37.88	36.75	-89.38	-14.75	-74.63	peak
5	0.0675	59.64	-101.56	-41.92	31.02	-93.42	-20.48	-72.94	peak
6	0.0981	57.27	-101.78	-44.51	27.77	-96.01	-23.73	-72.28	peak

Note: 1. Measurement = Reading Level + Correct Factor (dBuA/m= dBuV/m- 20Log10[120π] = dBuV/m- 51.5).

2. If Peak Result complies with AV and QP limit, AV and QP Result are deemed to comply with AV limit.

3. All 3 polarizations (Horizontal, Face-on and Face-off) of the loop antenna had been tested, but only the worst data recorded in the report.

**150 kHz ~ 490 kHz**

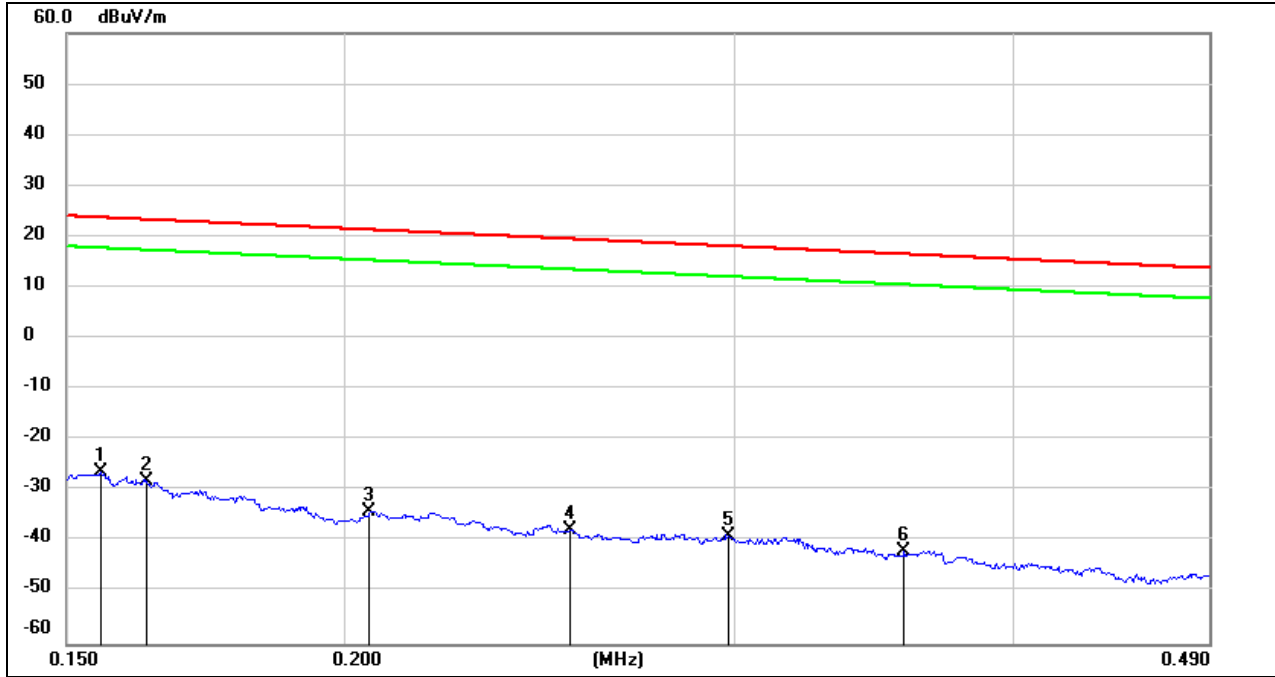

No.	Frequency (MHz)	Reading (dBuV)	Correct (dB/m)	FCC Result (dBuV/m)	FCC Limit (dBuV/m)	ISED Result (dBuA/m)	ISED Limit (dBuA/m)	Margin (dB)	Remark
1	0.1554	75.27	-101.65	-26.38	23.77	-77.88	-27.73	-50.15	peak
2	0.1630	73.49	-101.65	-28.16	23.36	-79.66	-28.14	-51.52	peak
3	0.2053	67.79	-101.73	-33.94	21.35	-85.44	-30.15	-55.29	peak
4	0.2530	64.14	-101.80	-37.66	19.54	-89.16	-31.96	-57.20	peak
5	0.2977	62.91	-101.85	-38.94	18.13	-90.44	-33.37	-57.07	peak
6	0.3573	60.08	-101.91	-41.83	16.54	-93.33	-34.96	-58.37	peak

Note: 1. Measurement = Reading Level + Correct Factor (dBuA/m= dBuV/m- 20Log10[120π] = dBuV/m- 51.5).

2. If Peak Result complies with AV and QP limit, AV and QP Result are deemed to comply with AV limit.

3. All 3 polarizations (Horizontal, Face-on and Face-off) of the loop antenna had been tested, but only the worst data recorded in the report.

**490 kHz ~ 30 MHz**

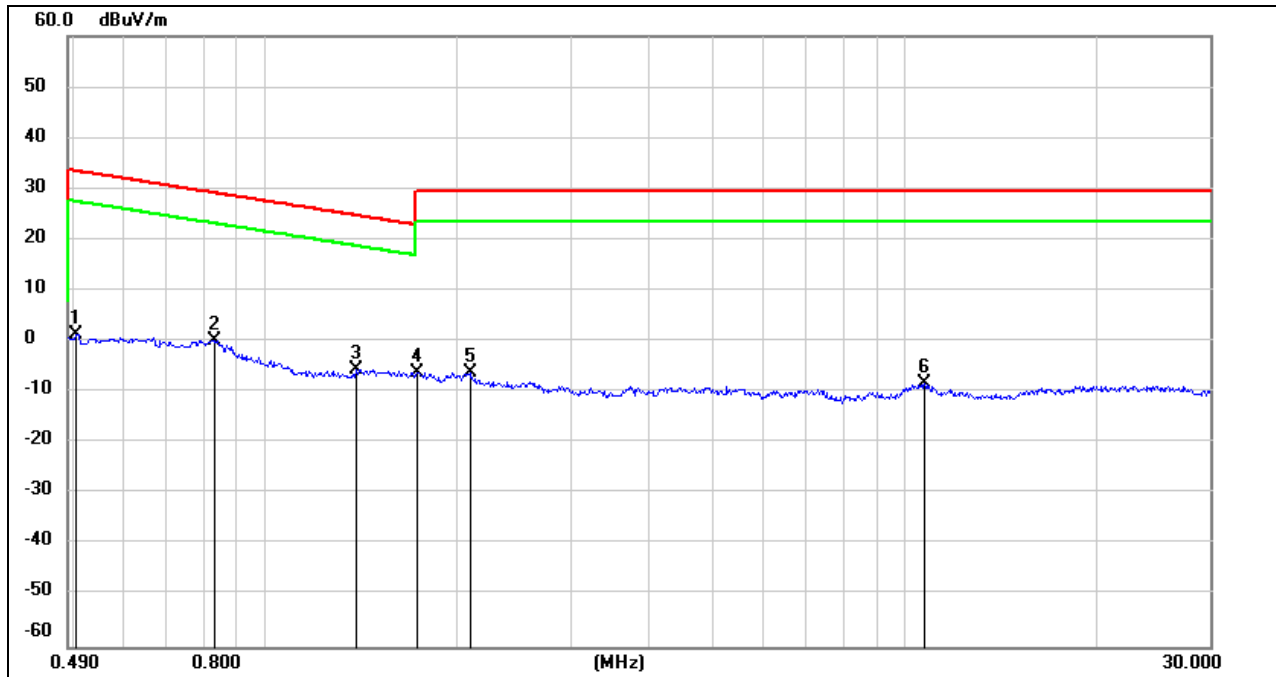

No.	Frequency (MHz)	Reading (dBuV)	Correct (dB/m)	FCC Result (dBuV/m)	FCC Limit (dBuV/m)	ISED Result (dBuA/m)	ISED Limit (dBuA/m)	Margin (dB)	Remark
1	0.5039	63.43	-62.07	1.36	33.56	-50.14	-17.94	-32.20	peak
2	0.8296	62.44	-62.17	0.27	29.23	-51.23	-22.27	-28.96	peak
3	1.3810	56.47	-62.10	-5.63	24.8	-57.13	-26.70	-30.43	peak
4	1.7294	55.79	-61.94	-6.15	29.54	-57.65	-21.96	-35.69	peak
5	2.0853	55.57	-61.80	-6.23	29.54	-57.73	-21.96	-35.77	peak
6	10.7299	52.48	-60.83	-8.35	29.54	-59.85	-21.96	-37.89	peak

Note: 1. Measurement = Reading Level + Correct Factor (dBuA/m= dBuV/m- 20Log10[120π] = dBuV/m- 51.5).

2. If Peak Result complies with AV and QP limit, AV and QP Result are deemed to comply with AV limit.

3. All 3 polarizations (Horizontal, Face-on and Face-off) of the loop antenna had been tested, but only the worst data recorded in the report.

Note: All the channels have been tested, only the worst data was recorded in the report.

## 9. AC POWER LINE CONDUCTED EMISSIONS

### LIMITS

Please refer to CFR 47 FCC §15.207 (a) and ISED RSS-Gen Clause 8.8

FREQUENCY (MHz)	Quasi-peak	Average
0.15 -0.5	66 - 56 *	56 - 46 *
0.50 -5.0	56.00	46.00
5.0 -30.0	60.00	50.00

### TEST SETUP AND PROCEDURE

Refer to ANSI C63.10-2013 clause 6.2.

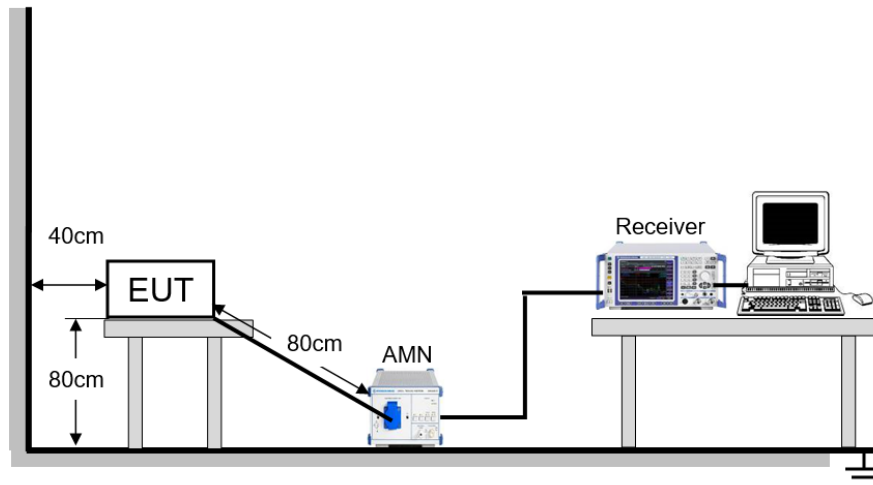

The EUT is put on a table of non-conducting material that is 80 cm high. The vertical conducting wall of shielding is located 40 cm to the rear of the EUT. The power line of the EUT is connected to the AC mains through a Artificial Mains Network (A.M.N.). A EMI Measurement Receiver (R&S Test Receiver ESR3) is used to test the emissions from both sides of AC line. According to the requirements in Section 6.2 of ANSI C63.10-2013. Conducted emissions from the EUT measured in the frequency range between 0.15 MHz and 30 MHz using CISPR Quasi-Peak and average detector mode. The bandwidth of EMI test receiver is set at 9 kHz.

The arrangement of the equipment is installed to meet the standards and operating in a manner, which tends to maximize its emission characteristics in a normal application.

### TEST ENVIRONMENT

Temperature	26.9 °C	Relative Humidity	54.8 %
Atmosphere Pressure	101 kPa	Test Voltage	AC120 V,60 Hz



**RESULTS**

**9.1. ZIGBEE MODE**

**LINE L RESULTS (MID CHANNEL, WORST-CASE CONFIGURATION)**

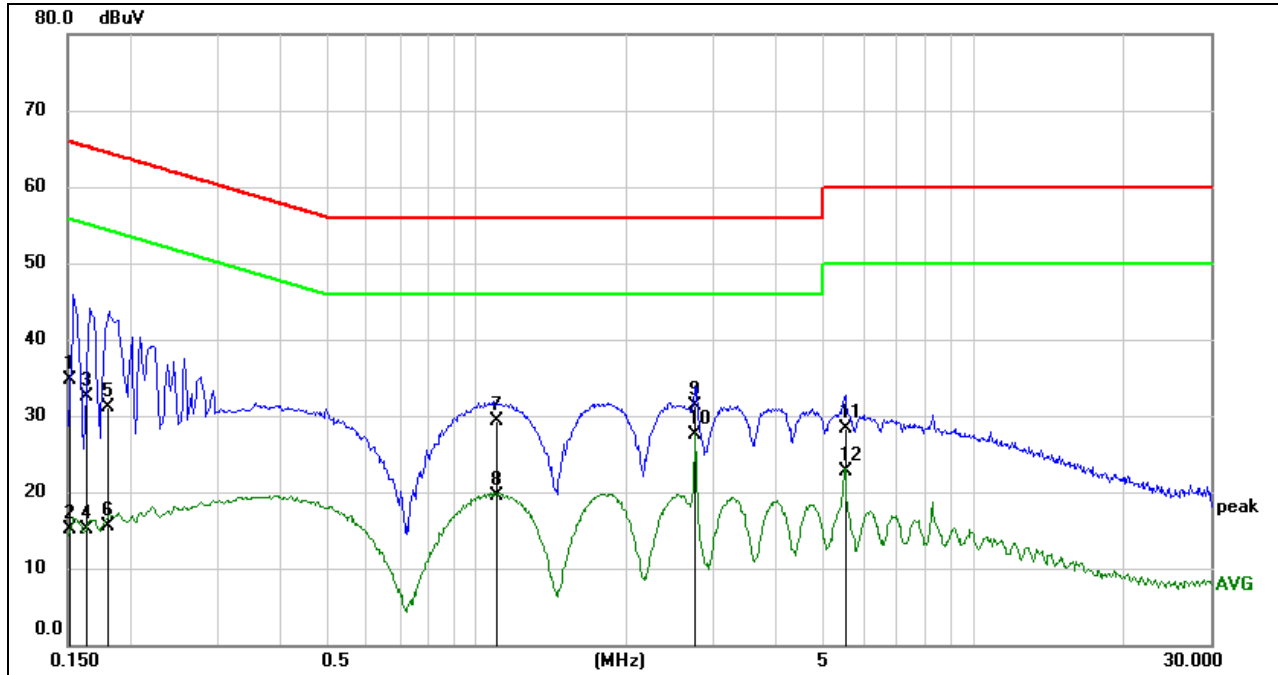

No.	Frequency (MHz)	Reading (dBuV)	Correct (dB)	Result (dBuV)	Limit (dBuV)	Margin (dB)	Remark
1	0.1514	25.21	9.59	34.80	65.92	-31.12	QP
2	0.1514	5.48	9.59	15.07	55.92	-40.85	AVG
3	0.1632	23.01	9.59	32.60	65.30	-32.70	QP
4	0.1632	5.57	9.59	15.16	55.30	-40.14	AVG
5	0.1802	21.61	9.59	31.20	64.48	-33.28	QP
6	0.1802	5.89	9.59	15.48	54.48	-39.00	AVG
7	1.0919	19.61	9.61	29.22	56.00	-26.78	QP
8	1.0919	9.97	9.61	19.58	46.00	-26.42	AVG
9	2.7544	21.68	9.62	31.30	56.00	-24.70	QP
10	2.7544	17.87	9.62	27.49	46.00	-18.51	AVG
11	5.5082	18.66	9.63	28.29	60.00	-31.71	QP
12	5.5082	13.00	9.63	22.63	50.00	-27.37	AVG

- Note: 1. Result = Reading + Correct Factor.  
 2. If QP Result complies with AV limit, AV Result is deemed to comply with AV limit.  
 3. Test setup: RBW: 200 Hz (9 kHz ~ 150 kHz), 9 kHz (150 kHz ~ 30 MHz).  
 4. Step size: 80 Hz (0.009 MHz ~ 0.15 MHz), 4 kHz (0.15 MHz ~ 30 MHz), Scan time: auto.

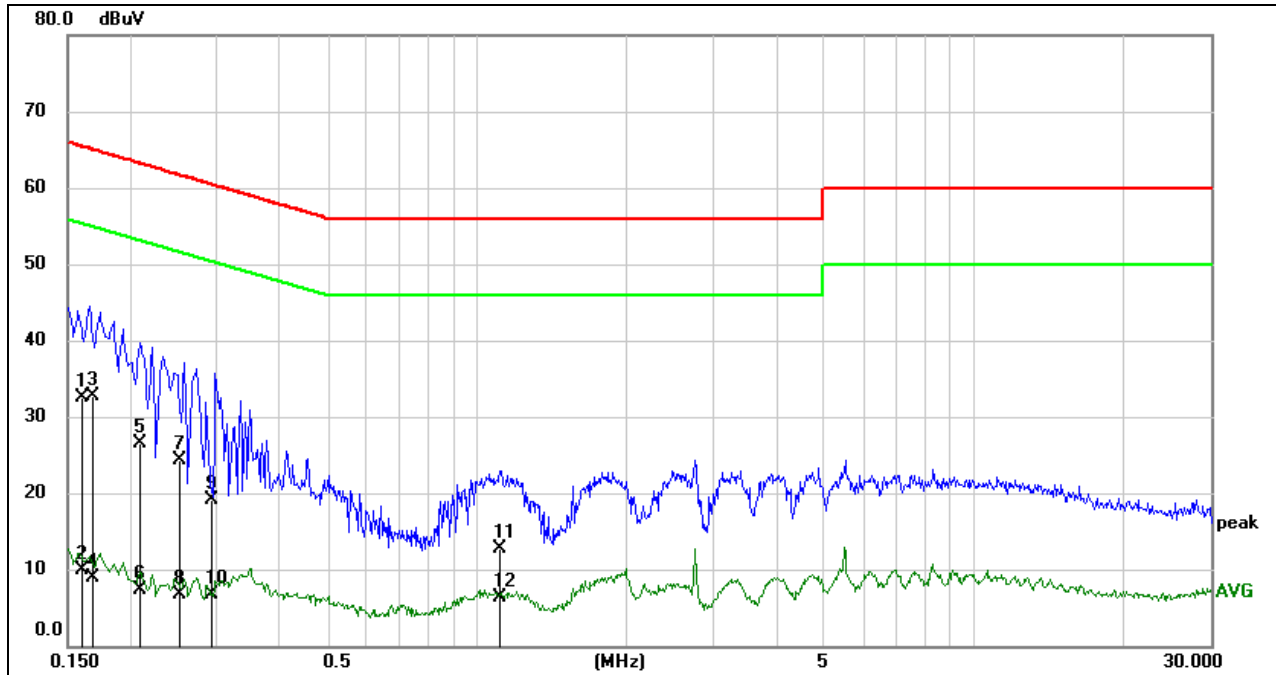

**LINE N RESULTS (MID CHANNEL, WORST-CASE CONFIGURATION)**

No.	Frequency (MHz)	Reading (dBuV)	Correct (dB)	Result (dBuV)	Limit (dBuV)	Margin (dB)	Remark
1	0.1614	22.88	9.59	32.47	65.39	-32.92	QP
2	0.1614	0.29	9.59	9.88	55.39	-45.51	AVG
3	0.1689	23.13	9.59	32.72	65.01	-32.29	QP
4	0.1689	-0.69	9.59	8.90	55.01	-46.11	AVG
5	0.2092	16.82	9.59	26.41	63.24	-36.83	QP
6	0.2092	-2.35	9.59	7.24	53.24	-46.00	AVG
7	0.2536	14.76	9.59	24.35	61.64	-37.29	QP
8	0.2536	-2.98	9.59	6.61	51.64	-45.03	AVG
9	0.2932	9.61	9.59	19.20	60.43	-41.23	QP
10	0.2932	-2.81	9.59	6.78	50.43	-43.65	AVG
11	1.1124	3.06	9.61	12.67	56.00	-43.33	QP
12	1.1124	-3.30	9.61	6.31	46.00	-39.69	AVG

Note: 1. Result = Reading + Correct Factor.

2. If QP Result complies with AV limit, AV Result is deemed to comply with AV limit.

3. Test setup: RBW: 200 Hz (9 kHz ~ 150 kHz), 9 kHz (150 kHz ~ 30 MHz).

4. Step size: 80 Hz (0.009 MHz ~ 0.15 MHz), 4 kHz (0.15 MHz ~ 30 MHz), Scan time: auto.

Note: All the modes and channels have been tested, only the worst data was recorded in the report.



## 10. ANTENNA REQUIREMENTS

### APPLICABLE REQUIREMENTS

Please refer to FCC §15.203

An intentional radiator shall be designed to ensure that no antenna other than that furnished by the responsible party shall be used with the device. The use of a permanently attached antenna or of an antenna that uses a unique coupling to the intentional radiator shall be considered sufficient to comply with the provisions of this section. The manufacturer may design the unit so that a broken antenna can be replaced by the user, but the use of a standard antenna jack or electrical connector is prohibited.

Please refer to FCC §15.247(b)(4)

The conducted output power limit specified in paragraph (b) of this section is based on the use of antennas with directional gains that do not exceed 6 dBi. Except as shown in paragraph (c) of this section, if transmitting antennas of directional gain greater than 6 dBi are used, the conducted output power from the intentional radiator shall be reduced below the stated values in paragraphs (b)(1), (b)(2), and (b)(3) of this section, as appropriate, by the amount in dB that the directional gain of the antenna exceeds 6 dBi.

### RESULTS

Complies



## 10.1. Appendix A: DTS Bandwidth

### 10.1.1. Test Result

Test Mode	Antenna	Channel	DTS BW [MHz]	FL[MHz]	FH[MHz]	Limit[MHz]	Verdict
Zigbee	Ant1	2405	1.295	2404.420	2405.715	0.5	PASS
		2445	1.455	2444.355	2445.810	0.5	PASS
		2480	1.290	2479.400	2480.690	0.5	PASS

### 10.1.2. Test Graphs





**10.2. Appendix B: Occupied Channel Bandwidth**  
**10.2.1. Test Result**

Test Mode	Antenna	Channel	OCB [MHz]	FL[MHz]	FH[MHz]	Verdict
Zigbee	Ant1	2405	2.3419	2403.881	2406.222	PASS
		2445	2.3271	2443.884	2446.211	PASS
		2480	2.3262	2478.876	2481.202	PASS



### 10.2.2. Test Graphs





**10.3. Appendix C: Maximum conducted output power**  
**10.3.1. Test Result**

Test Mode	Antenna	Channel	Result[dBm]	Limit[dBm]	Verdict
Zigbee	Ant1	2405	9.04	<=30	PASS
		2445	9.04	<=30	PASS
		2480	9.03	<=30	PASS



**10.4. Appendix D: Maximum power spectral density**  
**10.4.1. Test Result**

Test Mode	Antenna	Channel	Result[dBm/3kHz]	Limit[dBm/3kHz]	Verdict
Zigbee	Ant1	2405	-4.45	<=8	PASS
		2445	-4.40	<=8	PASS
		2480	-4.54	<=8	PASS





### 10.4.2. Test Graphs





## 10.5. Appendix E: Band edge measurements

### 10.5.1. Test Result

Test Mode	Antenna	ChName	Channel	RefLevel[dBm]	Result[dBm]	Limit[dBm]	Verdict
Zigbee	Ant1	Low	2405	4.01	-46.97	<=-15.99	PASS
		High	2480	2.93	-43.65	<=-17.07	PASS



### 10.5.2. Test Graphs





## 10.6. Appendix F: Conducted Spurious Emission

### 10.6.1. Test Result

Test Mode	Antenna	Channel	FreqRange [MHz]	Result[dBm]	Limit[dBm]	Verdict
Zigbee	Ant1	2405	Reference	3.63	---	PASS
			30~1000	-59.42	<=-16.37	PASS
			1000~26500	-56.54	<=-16.37	PASS
		2440	Reference	4.37	---	PASS
			30~1000	-59.8	<=-15.63	PASS
			1000~26500	-56.28	<=-15.63	PASS
		2480	Reference	5.01	---	PASS
			30~1000	-59.52	<=-14.99	PASS
			1000~26500	-56.5	<=-14.99	PASS



### 10.6.1. Test Graphs

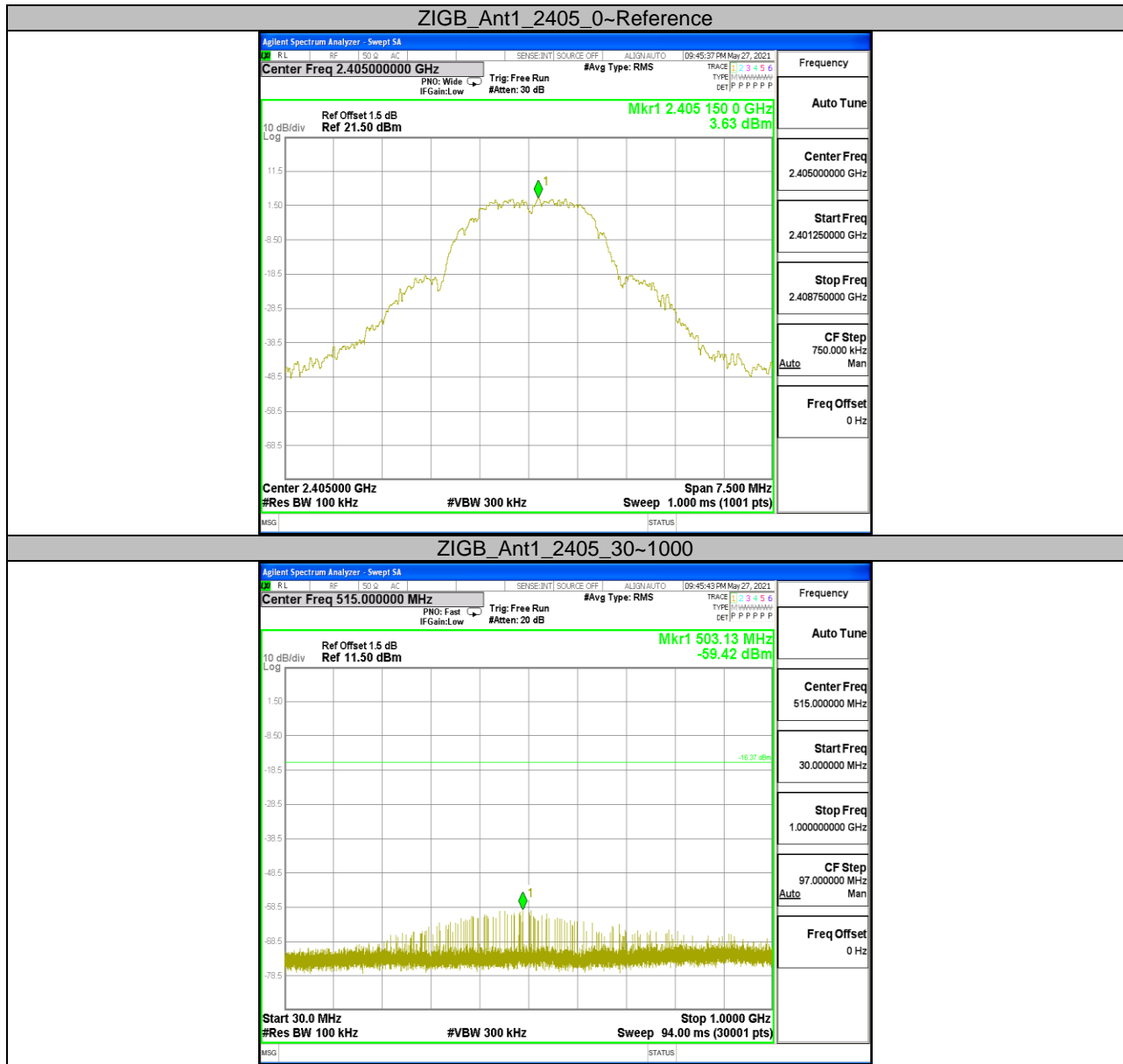

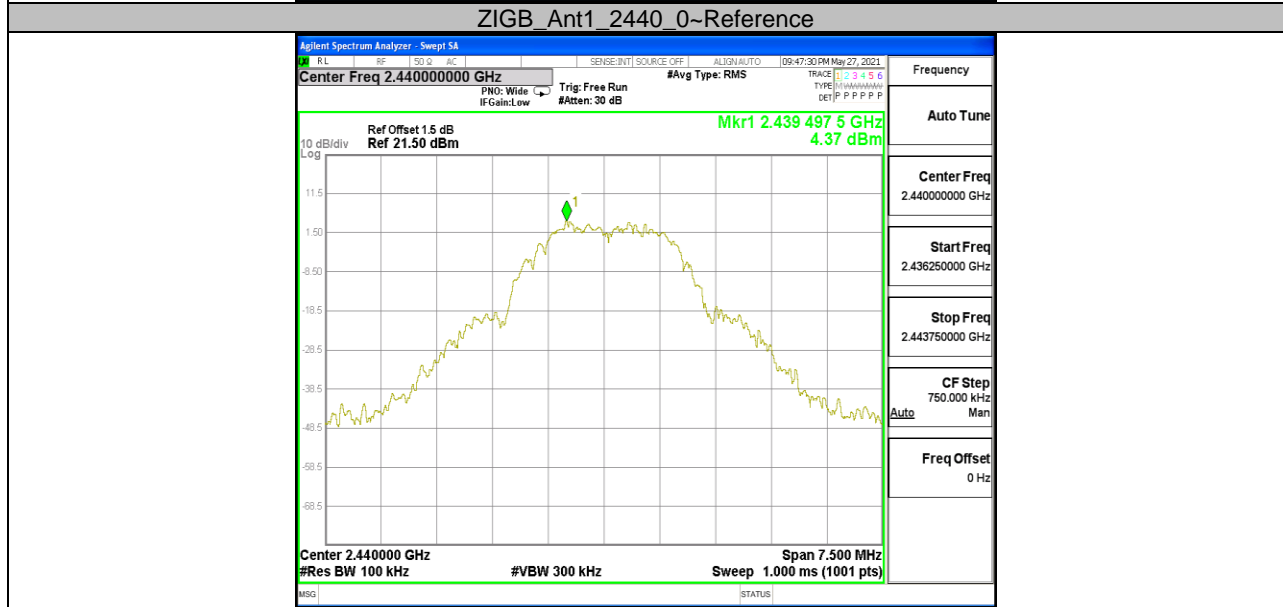
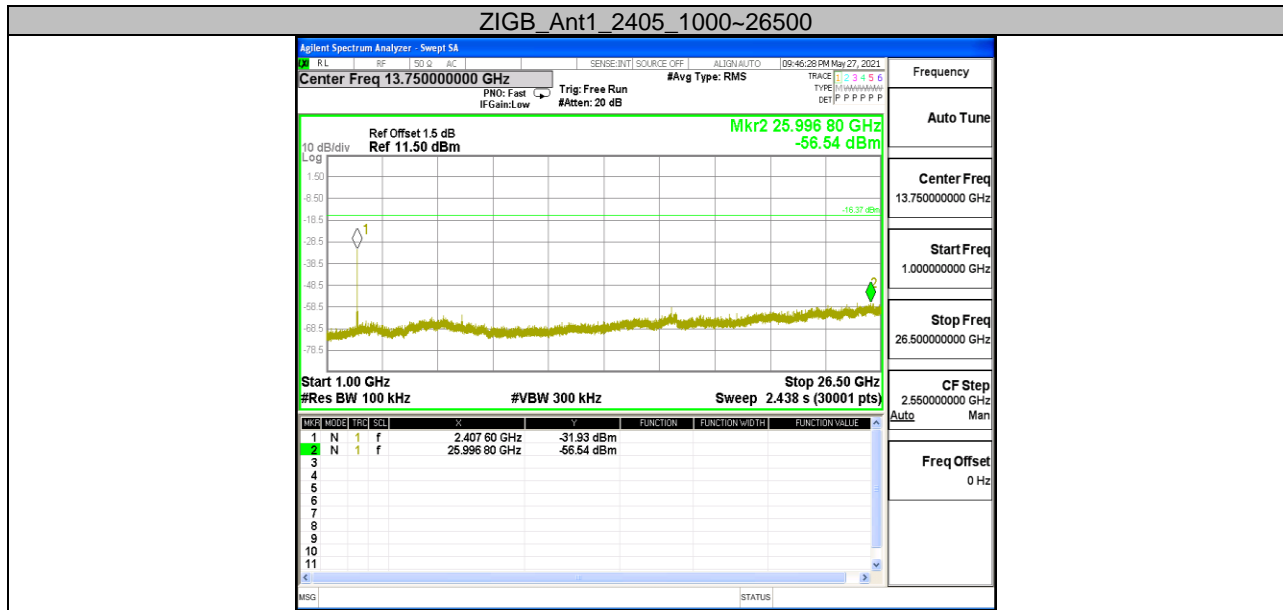

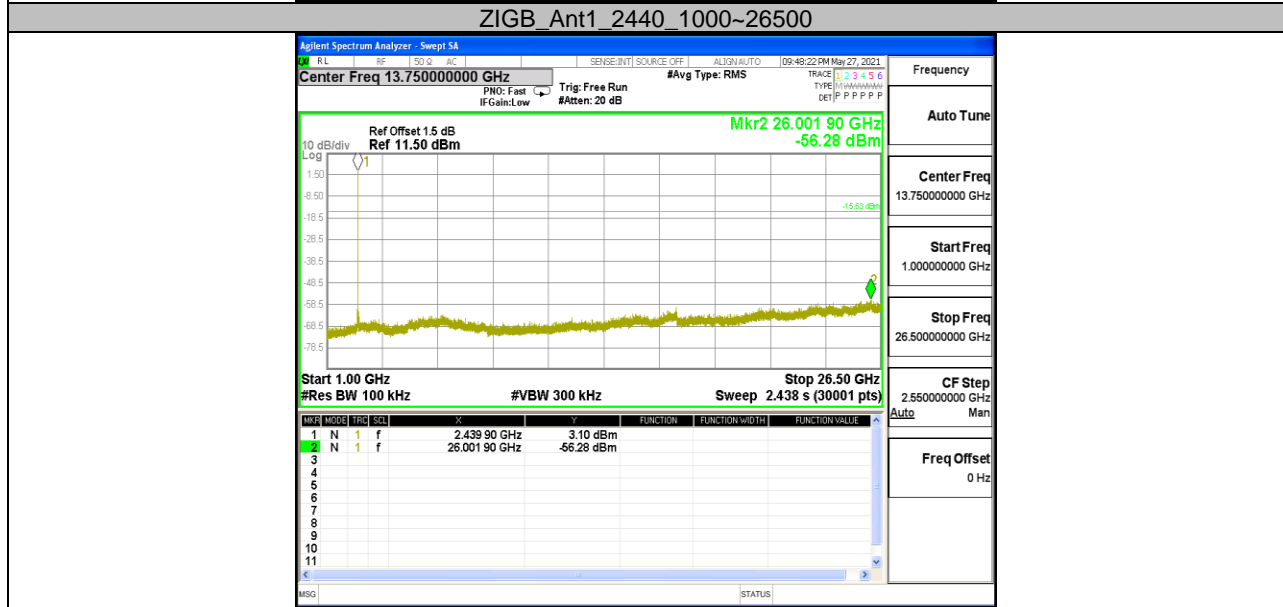
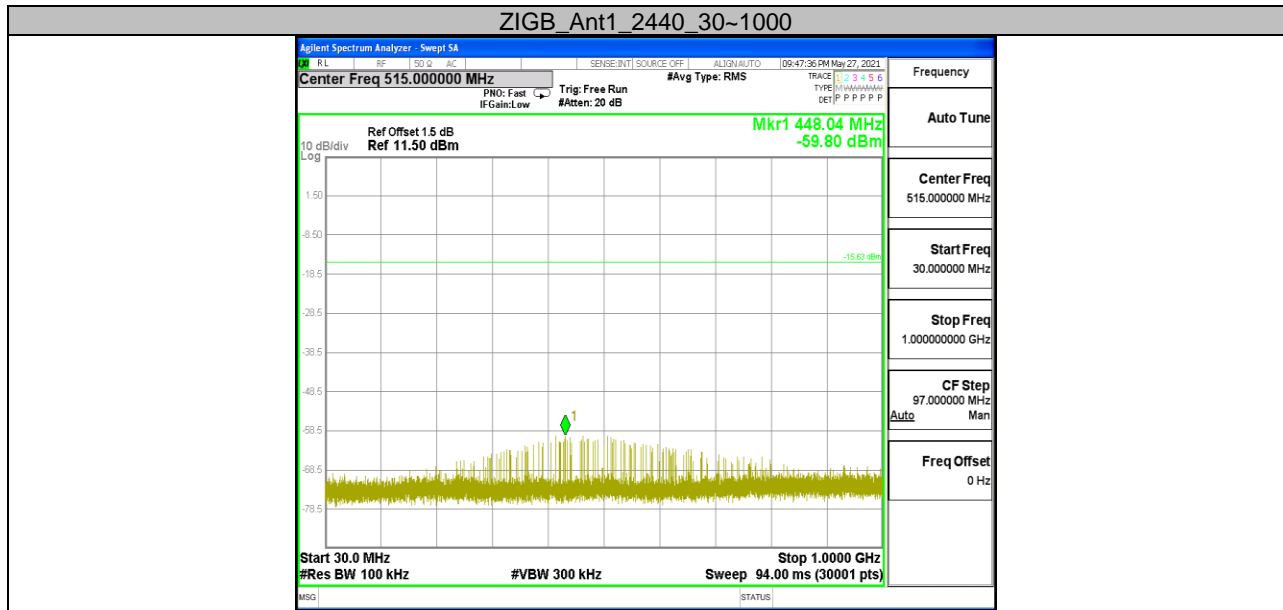

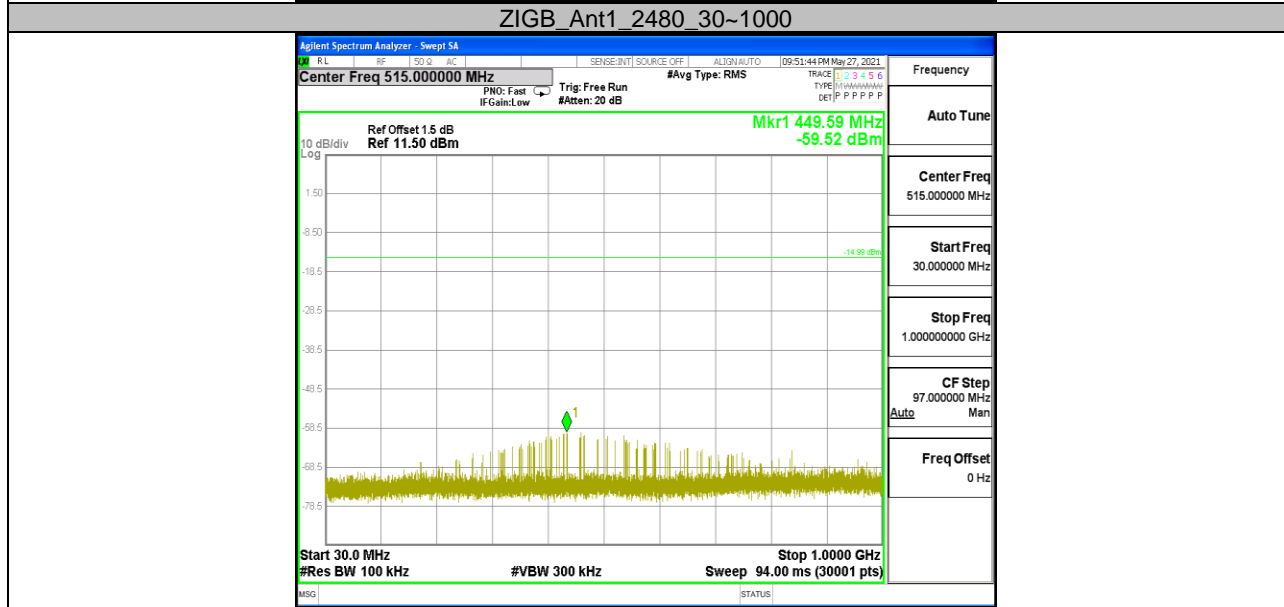
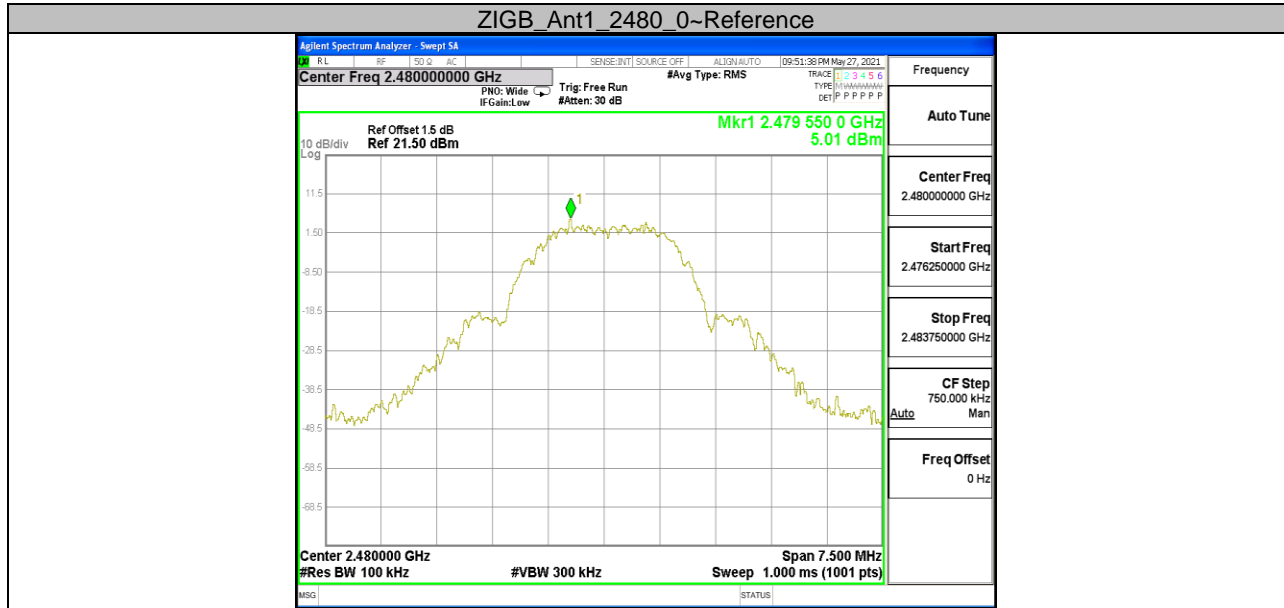



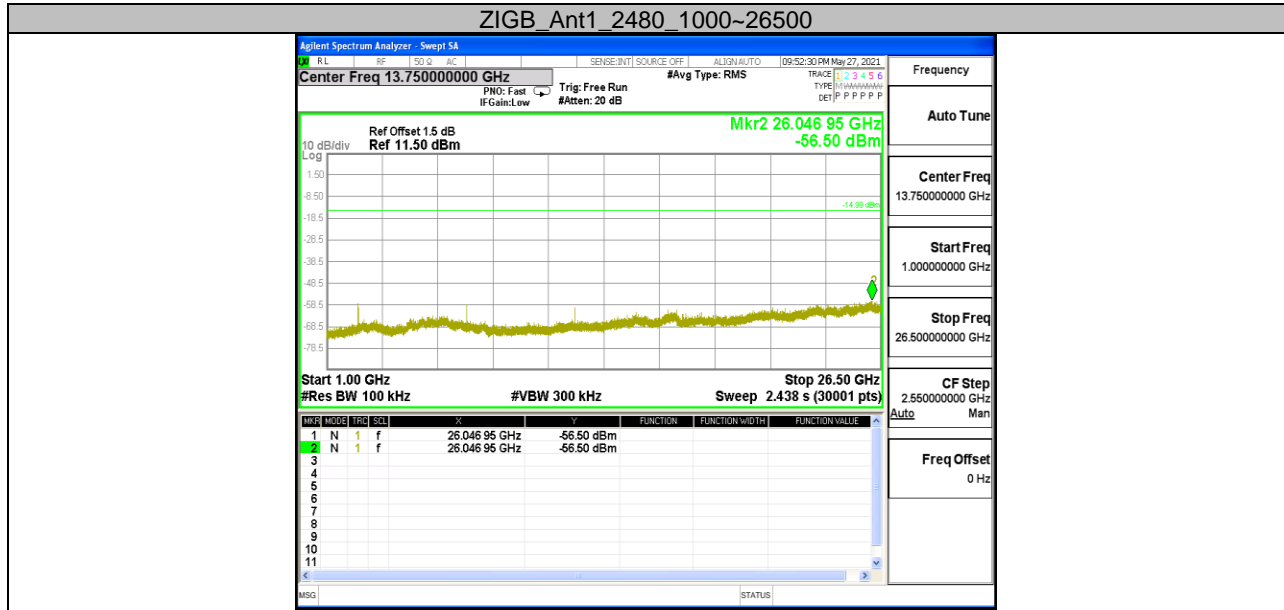

**10.7. Appendix G: Duty Cycle****10.7.1. Test Result**

Mode	On Time (msec)	Period (msec)	Duty Cycle x (Linear)	Duty Cycle (%)	Duty Cycle Correction Factor (dB)	1/T Minimum VBW (kHz)	Final setting For VBW (kHz)
Zigbee	2.83	20.95	0.1351	13.51	8.69	0.35	0.5

Note:

Duty Cycle Correction Factor=10log (1/x).

Where: x is Duty Cycle (Linear)

Where: T is On Time

If that calculated VBW is not available on the analyzer then the next higher value should be used.



### 10.7.2. Test Graphs

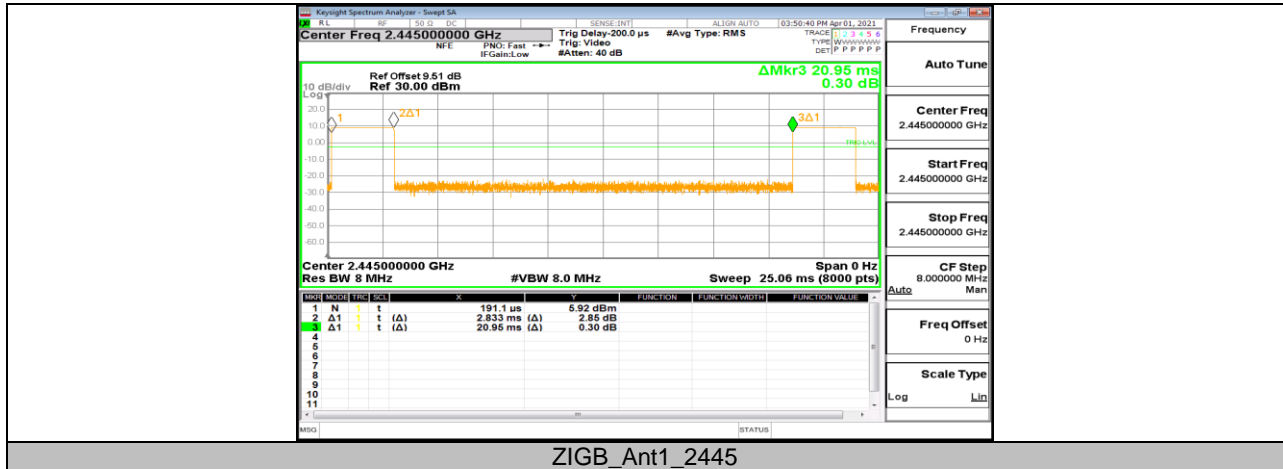

ZIGB\_Ant1\_2445

END OF REPORT