

Test Report

FCC Part15 Subpart C & RSS-247 Issue 2

Product Name : LED lamp
Model No. : 9290022275
FCC ID : 2AGBW9290022275X
IC : 20812-2275X

Applicant : Signify (China) Investment Co., Ltd.

Address : Building no.9, Lane 888, Tianlin Road, Minhang District,
Shanghai 200233, China

Date of Receipt : Aug. 08, 2019
Test Date : Aug. 10, 2019 ~ Sept. 12, 2019
Issued Date : Sep. 12, 2019
Report No. : 1982084R-RF-US-P06V02
Report Version : V1.0

This report is based on DEKRA report (report No. 1972175R), the only difference between 9290022275 and 9290022268 is appearance design.

The test results presented in this report relate only to the object tested.

This report shall not be reproduced, except in full, without the written approval of the Issuing CB Testing Laboratory.

The measurement result is considered in conformance with the requirement if it is within the prescribed limit, It is not necessary to calculate the uncertainty associated with the measurement result.

This report is not used for social proof in China (or Mainland China) market.

Test Report Certification

Issued Date : Sep. 12, 2019
Report No. : 1982084R-RF-US-P06V02



Product Name : LED lamp
 Applicant : Signify (China) Investment Co., Ltd.
 Address : Building no.9, Lane 888, Tianlin Road, Minhang District, Shanghai 200233, China
 Manufacturer : Signify (China) Investment Co., Ltd.
 Address : Building no.9, Lane 888, Tianlin Road, Minhang District, Shanghai 200233, China
 Model No. : 9290022275
 FCC ID : 2AGBW9290022275X
 IC : 20812-2275X
 EUT Voltage : 110-130 Vac, 50-60 Hz, 7W
 Test Voltage : AC 120V/60Hz
 Brand Name : PHILIPS
 Applicable Standard : FCC CFR Title 47 Part 15 Subpart C: 2017
 KDB 558074 D01v05r02
 RSS 247: Issue2; RSS GEN: Issue5
 ANSI C63.4:2014; ANSI C63.10:2013;
 Test Result : Complied
 Performed Location : DEKRA Testing and Certification (Suzhou) Co., Ltd.
 No.99 Hongye Rd., Suzhou Industrial Park, Suzhou, 215006, Jiangsu, China
 TEL: +86-512-6251-5088 / FAX: +86-512-6251-5098
 FCC Designation Number: CN1199;
 ISED CAB identifier: CN0040

Documented By : Kitty Li
 (Project Assistant: Kitty Li)

Reviewed By : Frank He
 (Senior Engineer: Frank He)

Approved By : Jack Zhang
 (Engineer Supervisor: Jack Zhang)

TABLE OF CONTENTS

Description	Page
1. General Information.....	6
1.1. EUT Description	6
1.2. Working Frequency of Each Channel:	7
1.3. Antenna information	7
1.4. Mode of Operation.....	8
1.5. Tested System Details	8
1.6. Configuration of Tested System.....	9
1.7. EUT Exercise Software.....	10
2. Technical Test.....	11
2.1. Summary of Test Result.....	11
2.2. Test Environment.....	13
2.3. Measurement Uncertainty	13
3. AC Power Line Conducted Emission	14
3.1. Test Equipment.....	14
3.2. Test Setup.....	14
3.3. Limit.....	15
3.4. Test Procedure	15
3.5. Test Result.....	16
4. Emissions in restricted frequency bands	20
4.1. Test Equipment.....	20
4.2. Test Setup.....	21
4.3. Limit.....	22
4.4. Test Procedure	22
4.5. EUT test Axis definition.....	26
4.6. Test Result.....	27
5. Emissions in non-restricted frequency bands	43
5.1. Test Equipment.....	43
5.2. Test Setup.....	43
5.3. Limit.....	44
5.4. Test Procedure	45
5.5. EUT test Axis definition.....	46
5.6. Test Result.....	47
6. Radiated Emission Band Edge	48
6.1. Test Equipment.....	48
6.2. Test Setup.....	49
6.3. Limit.....	49
6.4. Test Procedure	50

6.5.	EUT test definition	51
6.6.	Duty Cycle	52
6.7	Test Result	53
7.	Occupied Bandwidth	69
7.1.	Test Equipment.....	69
7.2.	Test Setup.....	69
7.3.	Limit.....	70
7.4.	Test Procedure	70
7.5.	EUT test definition	71
7.6.	Test Result.....	72
8.	Fundamental emission output power	76
8.1.	Test Equipment.....	76
8.2.	Test Setup.....	76
8.3.	Limit.....	77
8.4.	Test Procedure	78
8.5.	EUT test definition	79
8.6.	Test Result.....	80
9.	Power Spectral Density	81
9.1.	Test Equipment.....	81
9.2.	Test Setup.....	81
9.3.	Limit.....	81
9.4.	Test Procedure	82
9.5.	EUT test definition	83
9.6.	Test Result.....	84
10.	Antenna Requirement.....	86
10.1.	Limit.....	86
10.2.	Antenna Connector Construction.....	86

History of This Test Report

REPORT NO.	VERSION	DESCRIPTION	ISSUED DATE
1982084R-RF-US-P06V02	V1.0	Initial Issued Report	Sep. 12, 2019

1. General Information

1.1. EUT Description

Product Name	LED lamp
Model No.	9290022275
EUT Voltage	110-130 Vac, 50-60 Hz, 7W
Test Voltage	AC 120V/60Hz
Zigbee	
Frequency Range	2405 ~ 2480MHz
Channel Number	16
Type of Modulation	DSSS-OQPSK
Data Rate	250kbps
Antenna Type	Reference to Antenna List

Note 1: LED lamp supports two kinds of Crystal oscillator (murata/ Diodes), there is not any change in RF design, circuitry or construction for this device, including RF parameters (antenna, software, firmware and hardware versions, power, frequency ranges, etc.), so only power, spurious emission and band-edge were tested for different crystal oscillator, the test data of worse mode is showed with other test items.

1.2. Working Frequency of Each Channel:

Zigbee Working Frequency of Each Channel:							
Channel	Frequency	Channel	Frequency	Channel	Frequency	Channel	Frequency
11	2405 MHz	12	2410 MHz	13	2415 MHz	14	2420 MHz
15	2425 MHz	16	2430 MHz	17	2435 MHz	18	2440 MHz
19	2445 MHz	20	2450 MHz	21	2455 MHz	22	2460 MHz
23	2465 MHz	24	2470 MHz	25	2475 MHz	26	2480 MHz

1.3. Antenna information

Antenna manufacturer	N/A					
Antenna Delivery	<input checked="" type="checkbox"/>	1*TX+1*RX	<input type="checkbox"/>	2*TX+2*RX	<input type="checkbox"/>	3*TX+3*RX
Antenna technology	<input checked="" type="checkbox"/>	SISO				
	<input type="checkbox"/>	MIMO	<input type="checkbox"/>	Basic		
			<input type="checkbox"/>	CDD		
			<input type="checkbox"/>	Beam-forming		
Antenna Type	<input type="checkbox"/>	External	<input type="checkbox"/>	Dipole		
	<input checked="" type="checkbox"/>	Internal	<input type="checkbox"/>	PIFA		
			<input checked="" type="checkbox"/>	PCB		
			<input type="checkbox"/>	Ceramic Chip Antenna		
			<input type="checkbox"/>	Metal plate type F antenna		
Antenna Gain	0dBi					

1.4. Mode of Operation

Test Mode
Mode 1: Transmit
Mode 2: Normal operation

1.5. Tested System Details

The types for all equipment, plus descriptions of all cables used in the tested system (including inserted cards) are:

No.	Product	Manufacturer	Model No.	Serial No.	Power Cord
1	Notebook	Think Pad	2526	LV-A3285	Power by adapter
2	Zigbee Receiver	N/A	N/A	N/A	N/A
A	USB Control Cable	N/A	N/A	N/A	Shield, 1m
B	USB Control Cable	N/A	N/A	N/A	Shield, 10m

1.6. Configuration of Tested System

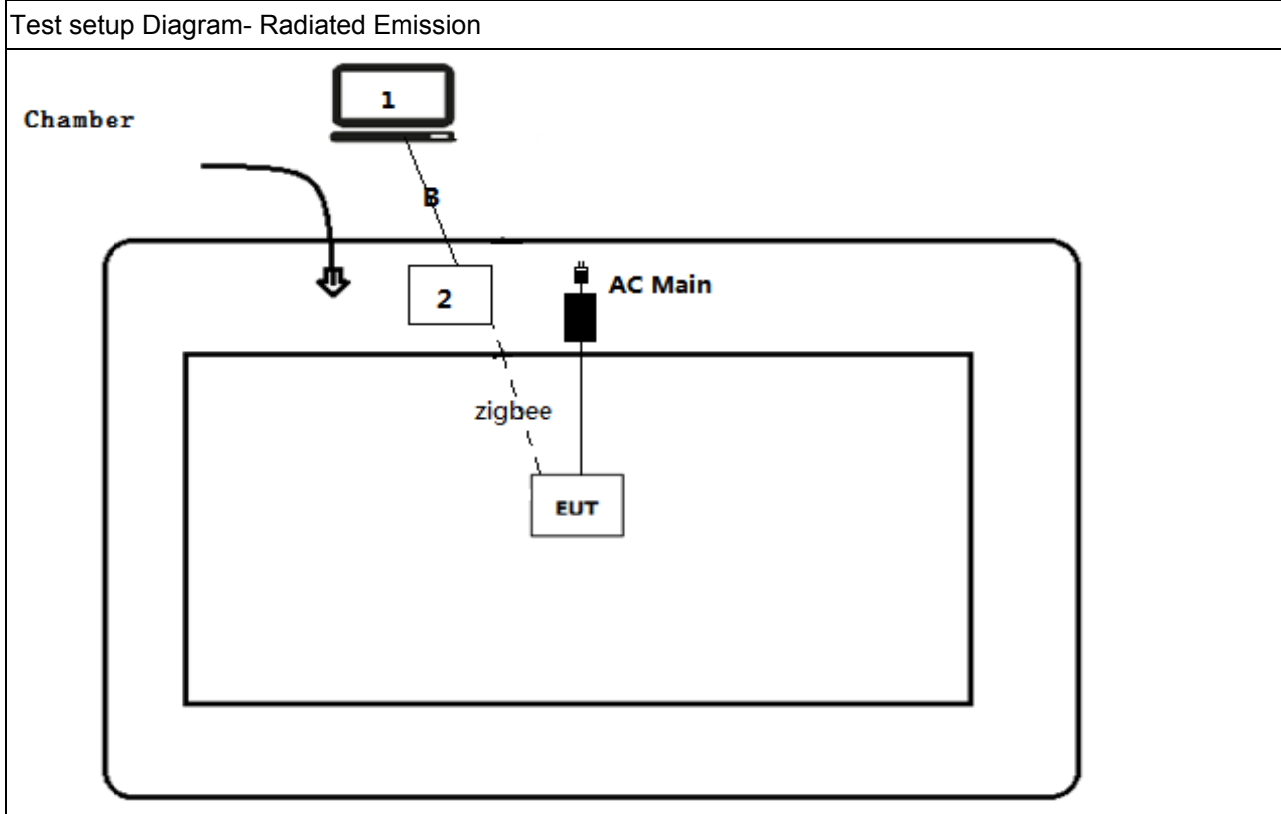
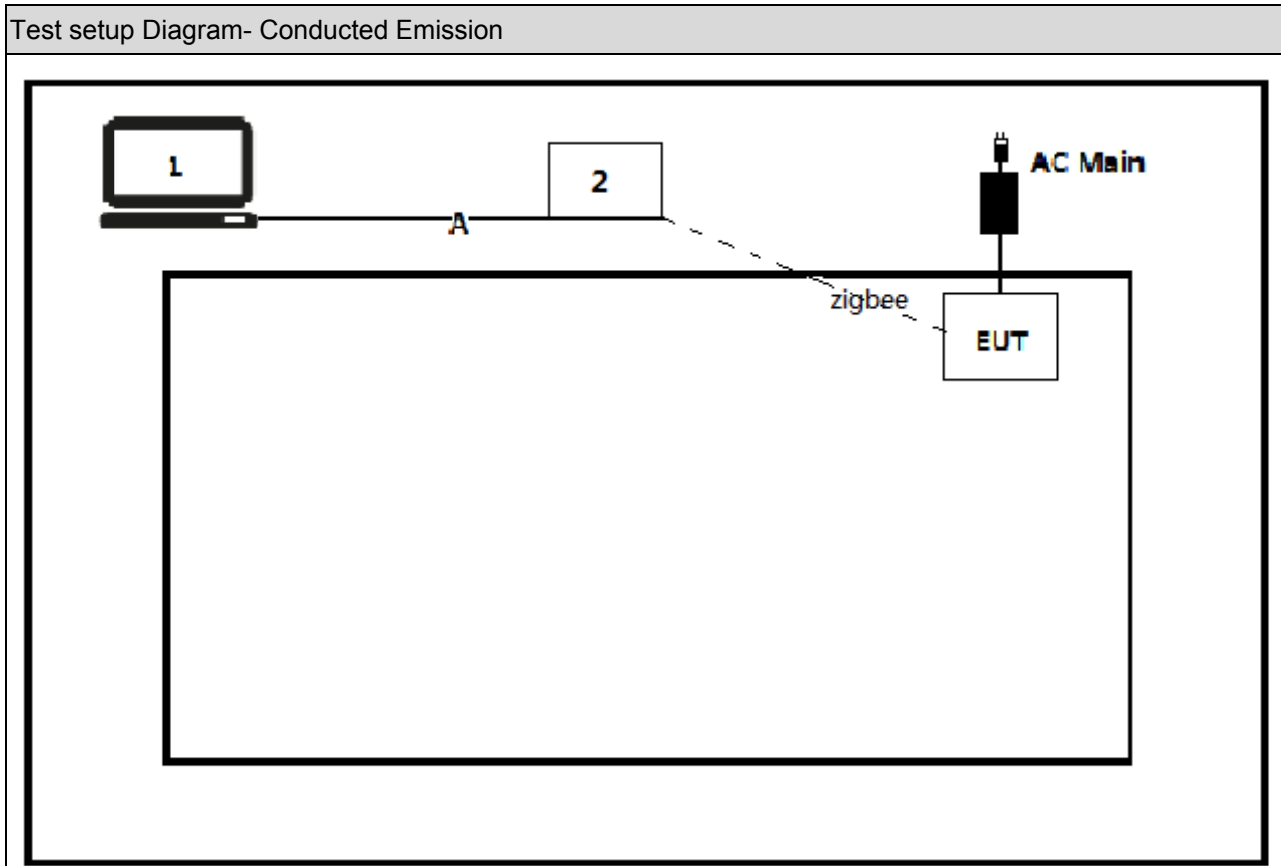

1.7. EUT Exercise Software

1	Setup the EUT and simulators as shown on above.
2	Turn on the power of equipment.
3	Run the test software (HueApprobaton Tool).
4	Select the transmission mode and test channel, then start test.

2. Technical Test
2.1. Summary of Test Result
FCC:

Performed Test Item	Normative References	Worst case mode	Limit	Result
AC Power Line Conducted Emission	FCC CFR Title 47 Part 15 Subpart C Section 15.207	Mode 1	FCC 15.207	PASS
Emissions in restricted frequency bands	FCC CFR Title 47 Part 15 Subpart C Section 15.209	Mode 1	FCC 15.209	PASS
Emissions in non-restricted frequency bands	FCC CFR Title 47 Part 15 Subpart C Section 15.247(d)	Mode 1	20dBc	PASS
Radiated Emission Band Edge	FCC CFR Title 47 Part 15 Subpart C 15.247(d)	Mode 1	FCC 15.209	PASS
Occupied Bandwidth	FCC CFR Title 47 Part 15 Subpart C Section 15.247(a)(2)	Mode 1	500kHz	PASS
Fundamental emission output power	FCC CFR Title 47 Part 15 Subpart C Section 15.247(b)(3)	Mode 1	30dBm	PASS
Power Spectral Density	FCC CFR Title 47 Part 15 Subpart C Section 15.247(e)	Mode 1	8dBm/3kHz	PASS
Antenna Requirement	FCC CFR Title 47 Part 15 Subpart C Section 15.203	N/A	FCC 15.203	PASS

ISED:

Performed Test Item	Normative References	Worse case mode	Limit	Result
AC Power Line Conducted Emission	RSS-Gen Issue 5 Section 8.8	N/A	RSS-Gen	PASS
Emissions in restricted frequency bands	RSS-Gen Issue 5 Section 8.10	Mode1	RSS-247	PASS
Emissions in non-restricted frequency bands	RSS-247 Issue 2 Section 5.5	Mode1	30dBc	PASS
Radiated Emission Band Edge	RSS-Gen Issue 5 Section 8.10	Mode1	RSS-Gen	PASS
Occupied Bandwidth	RSS-Gen Issue 5 Section 6.7	Mode1	500kHz	PASS
Fundamental emission output power	RSS-247 Issue 2 Section 5.4(d)	Mode1	30dBm	PASS
Power Spectral Density	RSS-247 Issue 2 Section 5.2(b)	Mode1	8dBm/3kHz	PASS
Antenna Requirement	RSS-Gen Issue 5 Section 6.8	N/A	RSS-Gen	PASS

2.2. Test Environment

Items	Required (IEC 68-1)	Actual
Temperature (°C)	15-35	21
Humidity (%RH)	25-75	50
Barometric pressure (mbar)	860-1060	950-1000

2.3. Measurement Uncertainty

Test Items	Uncertainty
AC Power Line Conducted Emission	± 2.02dB
Radiated Emission	Below 1GHz ± 3.8 dB
	Above 1GHz ± 3.9 dB
RF Antenna Port Conducted Emission	± 1.27dB
Radiated Emission Band Edge	± 3.9dB
Occupied Bandwidth	± 1kHz
Power Spectral Density	± 1.27dB

3. AC Power Line Conducted Emission

3.1. Test Equipment

AC Power Line Conducted Emission / TR-1					
Instrument	Manufacturer	Type No.	Serial No.	Cal. Date	Cal. Due Date
EMI Test Receiver	R&S	ESCI	100906	2019.03.05	2020.03.04
Two-Line V-Network	R&S	ENV 216	101189	2019.07.16	2020.07.15
Two-Line V-Network	R&S	ENV 216	101044	2018.09.16	2019.09.15
50ohm Coaxial Switch	Anritsu	MP59B	6200464462	N/A	N/A
50ohm Termination	SHX	TF2	07081402	2018.09.16	2019.09.15
Temperature/Humidity Meter	Zhichen	ZC1-2	TR1-TH	2019.01.05	2020.01.04

Note: All equipments are calibrated with traceable calibrations. Each calibration is traceable to the national or international standards.

3.2. Test Setup

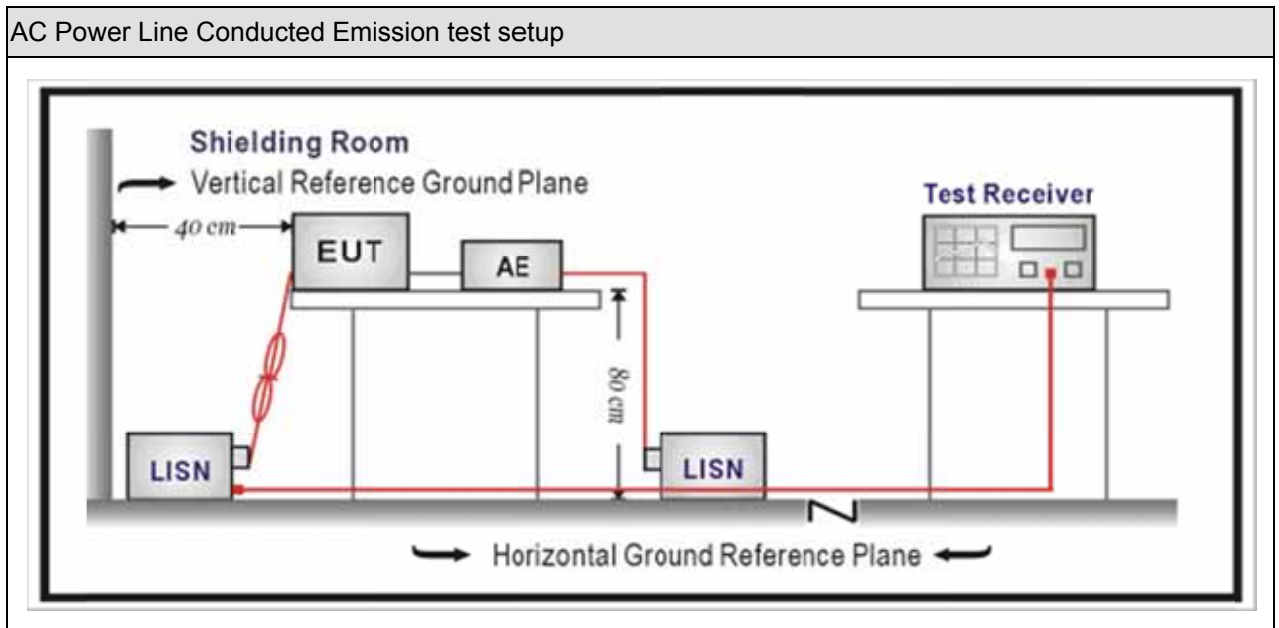

3.3. Limit

Frequency of Emission (MHz)	Conducted Limit	
	Quasi-peak (dB μ V)	Average (dB μ V)
0.15-0.5	66 to 56	56 to 46
0.5-5	56	46
5-30	60	50

Note 1: The lower limit shall apply at the transition frequencies.
 Note 2: The limit decreases linearly with the logarithm of the frequency in the range 0.15 MHz to 0.5 MHz.

3.4. Test Procedure

Test Method			
	References Rule	Chapter	Item
<input checked="" type="checkbox"/>	ANSI C63.10-2013	6.2	Standard test method for ac power-line conducted emissions from unlicensed wireless devices
<input checked="" type="checkbox"/>	ANSI C63.4-2014	7	AC power-line conducted emission measurements

3.5. Test Result

Muruta:

Engineer: Xu Jun	
Site: TR1	Time: 2019/04/13 - 11:10
Limit: FCC_Part15.207_CE_AC Power_ClassB	Margin: 0
Probe: ENV216_101190(0.009-30MHz)	Polarity: Neutral
EUT: LED lamp	Power: AC 120V/60Hz
Note: Mode 2: Normal operation	

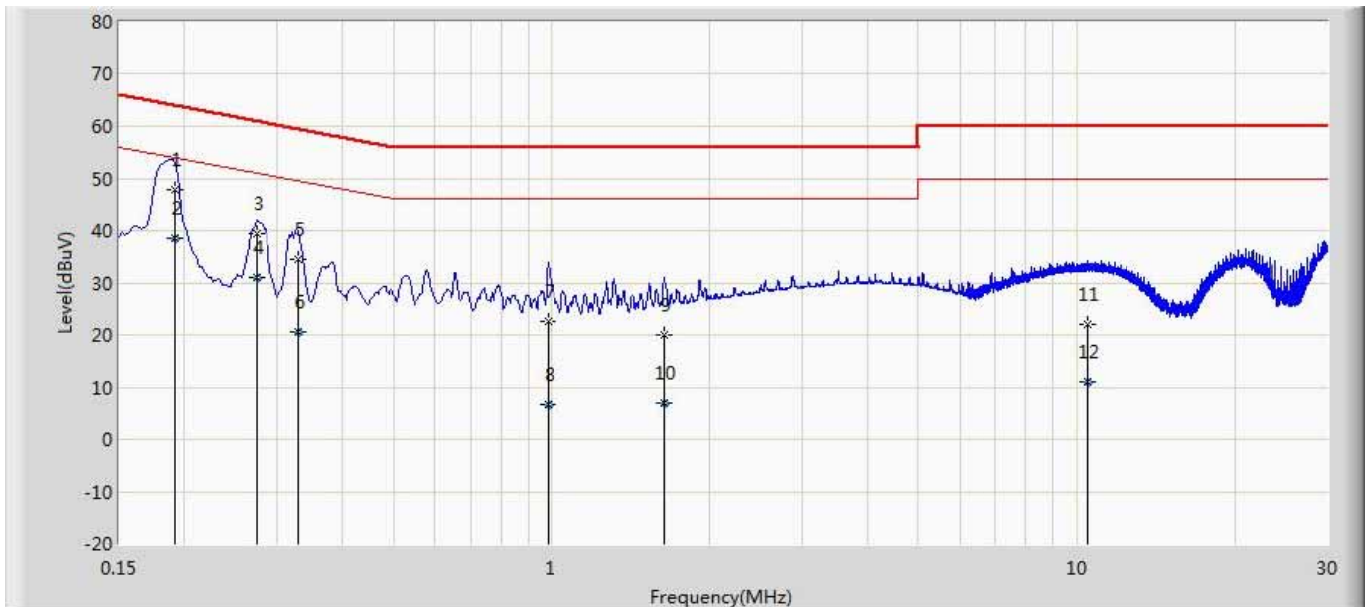

No	Mark	Frequency (MHz)	Measure Level (dBuV)	Reading Level (dBuV)	Over Limit (dB)	Limit (dBuV)	Factor (dB)	Type
1		0.192	47.969	38.343	-15.965	63.934	9.626	QP
2	*	0.192	38.428	28.802	-15.506	53.934	9.626	AV
3		0.274	39.312	29.682	-21.692	61.003	9.630	QP
4		0.274	31.005	21.375	-19.999	51.003	9.630	AV
5		0.330	34.562	24.933	-24.890	59.451	9.628	QP
6		0.330	20.644	11.016	-28.807	49.451	9.628	AV
7		0.985	22.602	12.954	-33.398	56.000	9.647	QP
8		0.985	6.663	-2.984	-39.337	46.000	9.647	AV
9		1.637	19.913	10.235	-36.087	56.000	9.678	QP
10		1.637	6.881	-2.797	-39.119	46.000	9.678	AV
11		10.469	21.980	11.966	-38.020	60.000	10.014	QP
12		10.469	10.886	0.872	-39.114	50.000	10.014	AV

Engineer: Xu Jun	
Site: TR1	Time: 2019/08/20 - 23:59
Limit: FCC_Part15.207_CE_AC Power_ClassB	Margin: 0
Probe: ENV216_101190(0.009-30MHz)	Polarity: Line
EUT: LED lamp	Power: AC 120V/60Hz
Note: Mode 2: Normal operation	

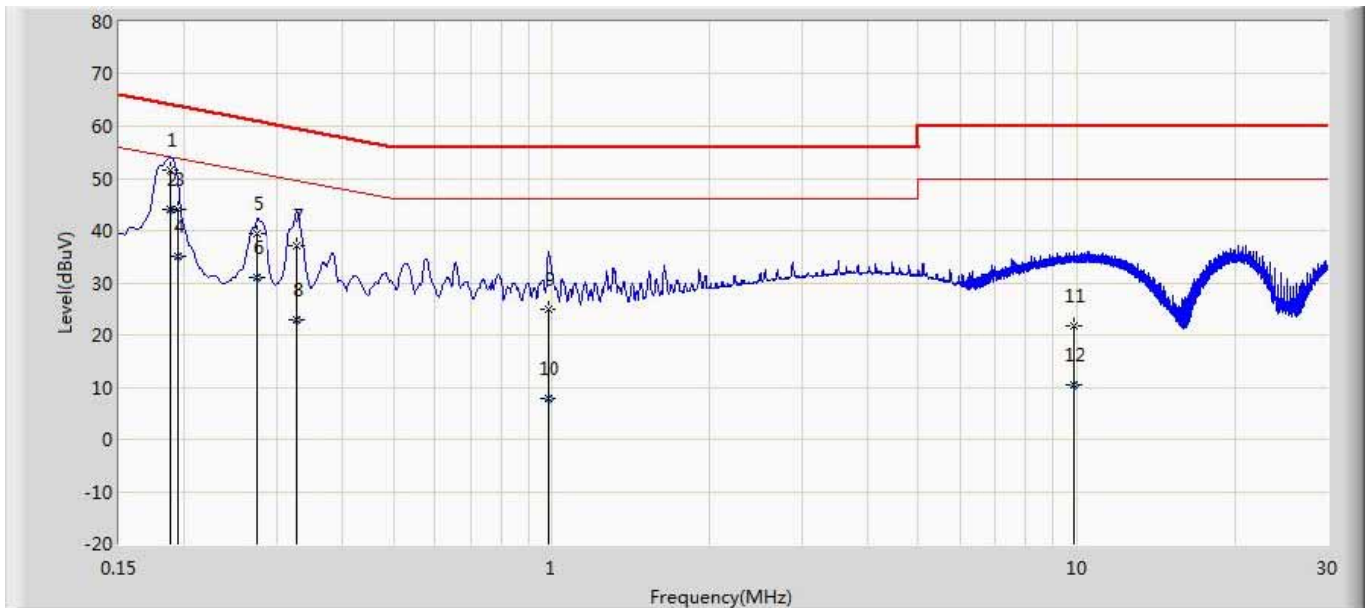

No	Mark	Frequency (MHz)	Measure Level (dBuV)	Reading Level (dBuV)	Over Limit (dB)	Limit (dBuV)	Factor (dB)	Type
1		0.188	51.516	41.887	-12.597	64.113	9.629	QP
2	*	0.188	44.043	34.413	-10.071	54.113	9.629	AV
3		0.194	44.108	34.477	-19.757	63.865	9.631	QP
4		0.194	35.002	25.371	-18.863	53.865	9.631	AV
5		0.274	39.389	29.757	-21.614	61.003	9.633	QP
6		0.274	31.109	21.476	-19.895	51.003	9.633	AV
7		0.328	37.014	27.381	-22.494	59.508	9.633	QP
8		0.328	22.788	13.156	-26.720	49.508	9.633	AV
9		0.985	24.922	15.255	-31.078	56.000	9.667	QP
10		0.985	7.761	-1.905	-38.239	46.000	9.667	AV
11		9.841	21.601	11.631	-38.399	60.000	9.970	QP
12		9.841	10.421	0.451	-39.579	50.000	9.970	AV

Note:

1. " * ", means this data is the worst emission level.
2. Measurement Level = Reading Level + Factor(Probe+Cable-Amp).

Diodes:

Engineer: Xu Jun	
Site: TR1	Time: 2019/08/21 - 00:06
Limit: FCC_Part15.207_CE_AC Power_ClassB	Margin: 0
Probe: ENV216_101190(0.009-30MHz)	Polarity: Neutral
EUT: LED lamp	Power: AC 120V/60Hz
Note: Mode 2: Normal operation	

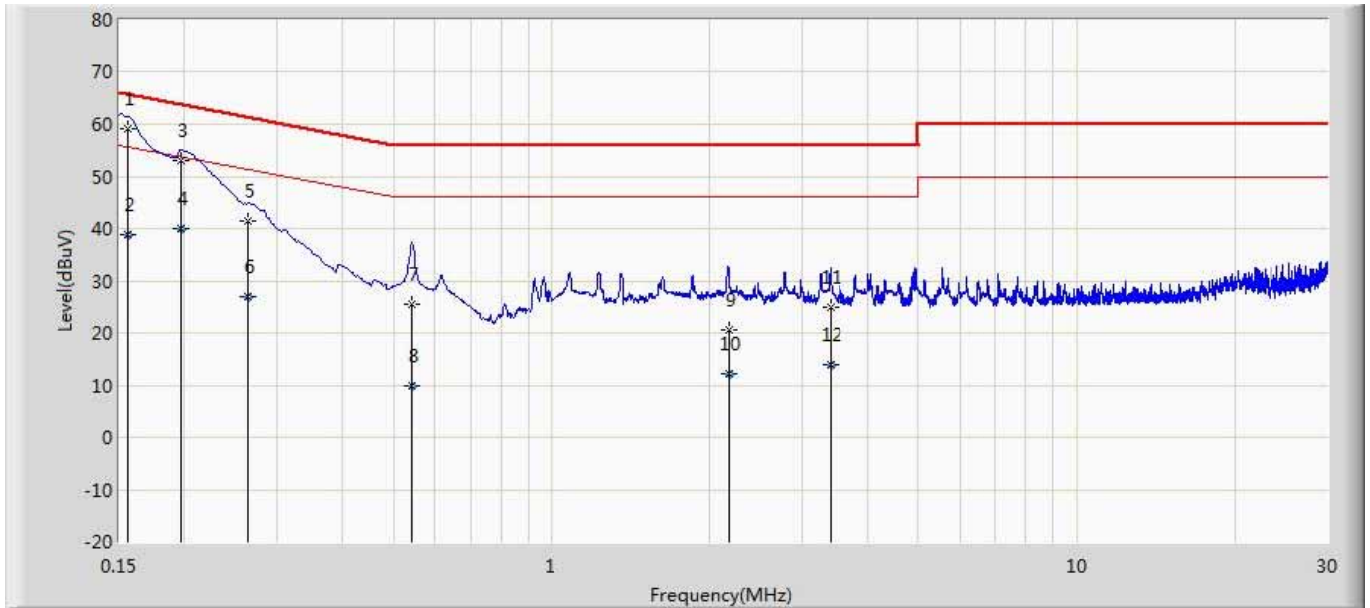

No	Mark	Frequency (MHz)	Measure Level (dBuV)	Reading Level (dBuV)	Over Limit (dB)	Limit (dBuV)	Factor (dB)	Type
1	*	0.156	59.204	49.589	-6.452	65.656	9.615	QP
2		0.156	38.899	29.284	-16.757	55.656	9.615	AV
3		0.197	53.172	43.544	-10.554	63.726	9.628	QP
4		0.197	40.098	30.470	-13.627	53.726	9.628	AV
5		0.263	41.464	31.835	-19.888	61.352	9.630	QP
6		0.263	27.025	17.395	-24.327	51.352	9.630	AV
7		0.541	25.516	15.877	-30.484	56.000	9.639	QP
8		0.541	9.886	0.247	-36.114	46.000	9.639	AV
9		2.175	20.600	10.892	-35.400	56.000	9.707	QP
10		2.175	12.275	2.568	-33.725	46.000	9.707	AV
11		3.390	24.826	15.080	-31.174	56.000	9.746	QP
12		3.390	13.880	4.134	-32.120	46.000	9.746	AV

Engineer: Xu Jun	
Site: TR1	Time: 2019/08/21 - 00:11
Limit: FCC_Part15.207_CE_AC Power_ClassB	Margin: 0
Probe: ENV216_101190(0.009-30MHz)	Polarity: Line
EUT: LED lamp	Power: AC 120V/60Hz
Note: Mode 2: Normal operation	

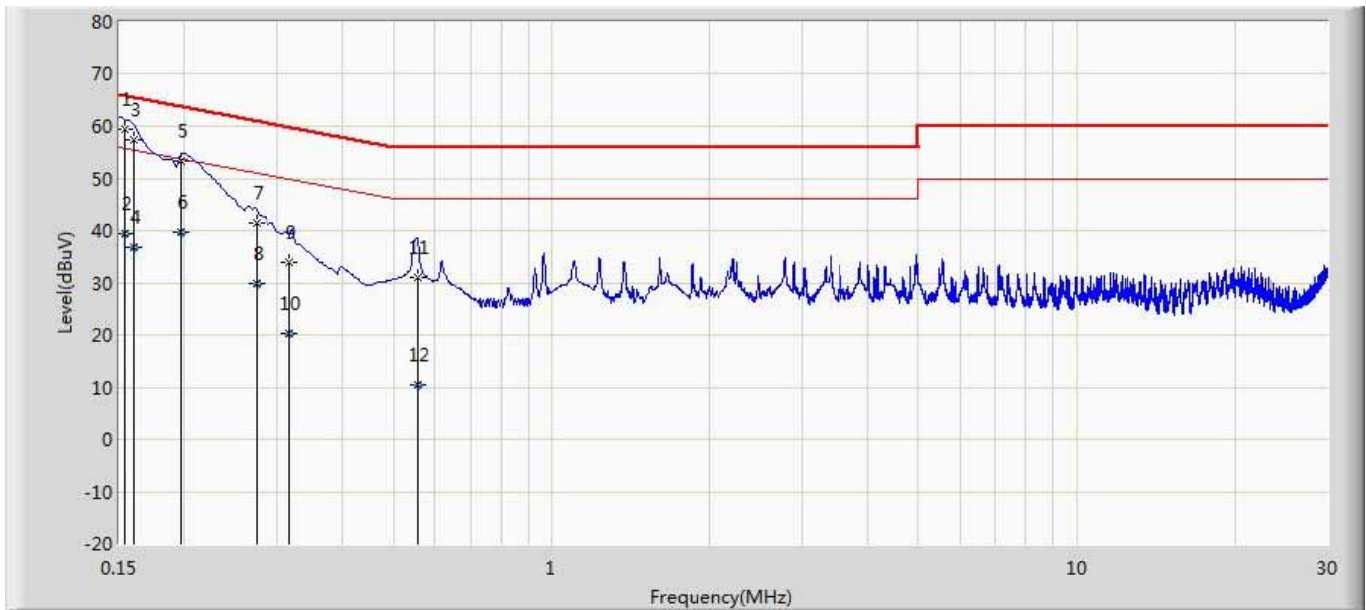

No	Mark	Frequency (MHz)	Measure Level (dBuV)	Reading Level (dBuV)	Over Limit (dB)	Limit (dBuV)	Factor (dB)	Type
1	*	0.154	59.468	49.838	-6.286	65.754	9.631	QP
2		0.154	39.397	29.766	-16.358	55.754	9.631	AV
3		0.160	57.506	47.876	-7.943	65.449	9.630	QP
4		0.160	36.787	27.157	-18.662	55.449	9.630	AV
5		0.197	53.305	43.674	-10.421	63.726	9.631	QP
6		0.197	39.711	30.080	-14.015	53.726	9.631	AV
7		0.274	41.331	31.698	-19.672	61.003	9.633	QP
8		0.274	29.730	20.097	-21.273	51.003	9.633	AV
9		0.317	33.823	24.191	-25.975	59.798	9.632	QP
10		0.317	20.170	10.538	-29.628	49.798	9.632	AV
11		0.555	31.010	21.364	-24.990	56.000	9.647	QP
12		0.555	10.340	0.693	-35.660	46.000	9.647	AV

Note:

1. " * ", means this data is the worst emission level.
2. Measurement Level = Reading Level + Factor(Probe+Cable-Amp).

4. Emissions in restricted frequency bands

4.1. Test Equipment

Radiated Emission(Below 1GHz) / AC-2					
Instrument	Manufacturer	Type No.	Serial No.	Cal. Date	Cal. Due Date
EMI Test Receiver	R&S	ESCI	100573	2019.03.29	2020.03.28
Loop Antenna	R&S	HFH2-Z2	833799/003	2018.11.16	2019.11.15
Bilog Antenna	Teseq GmbH	CBL6112D	27611	2018.10.16	2019.10.15
Coaxial Cable	Huber+Suhner	SUCOFLEX 106	AC2-C	2019.03.02	2020.03.01
Temperature/Humidity Meter	Zhichen	ZC1-2	AC2-TH	2019.01.04	2020.01.03
Note: All equipments are calibrated with traceable calibrations. Each calibration is traceable to the national or international standards.					

Radiated Emission(Above 1GHz) / AC-5					
Instrument	Manufacturer	Type No.	Serial No.	Cal. Date	Cal. Due Date
Spectrum Analyzer	Agilent	E4446A	MY45300103	2019.01.04	2020.01.03
Preamplifier	Miteq	NSP1800-25	1364185	2019.05.06	2020.05.05
Preamplifier	QuieTek	AP-040G	CHM-0906001	2019.05.06	2020.05.05
DRG Horn	ETS-Lindgren	3117	00123988	2019.01.22	2020.01.21
Broad-Band Horn Antenna	Schwarzbeck	BBHA9170	294	2018.11.25	2019.11.24
Coaxial Cable	Huber+Suhner	SUCOFLEX 106	AC5-C1	2019.03.02	2020.03.01
Coaxial Cable	Huber+Suhner	SUCOFLEX 106	AC5-C2	2019.03.02	2020.03.01
Coaxial Cable	Huber+Suhner	SUCOFLEX 102	AC5-C3	2019.03.02	2020.03.01
EMI Receiver	Agilent	N9038A	MY51210196	2019.06.10	2020.06.09
Temperature/Humidity Meter	Zhichen	ZC1-2	AC5-TH	2019.01.04	2020.01.03
Note: All equipments are calibrated with traceable calibrations. Each calibration is traceable to the national or international standards.					

4.2. Test Setup

Below 30MHz Test Setup:

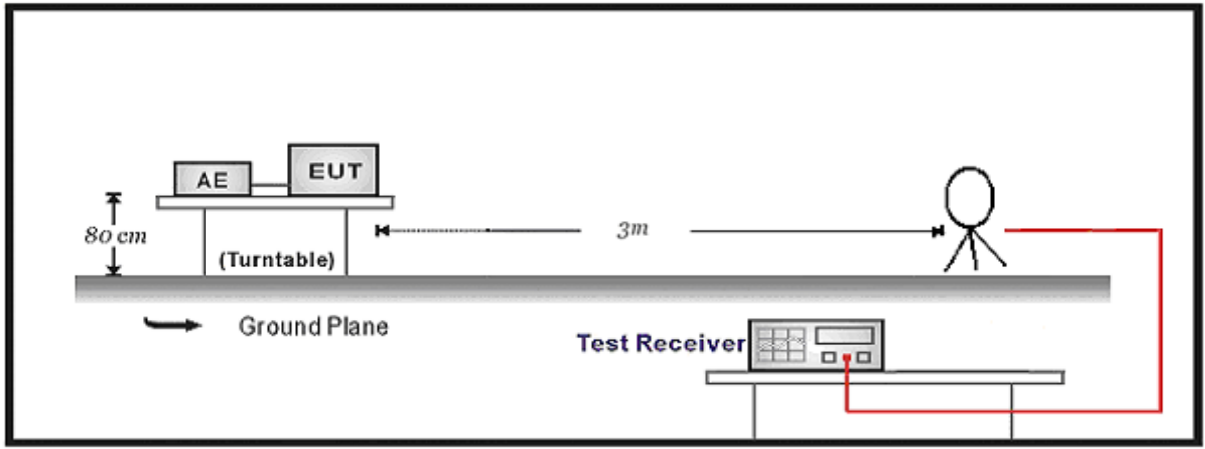

30MHz-1GHz Test Setup:

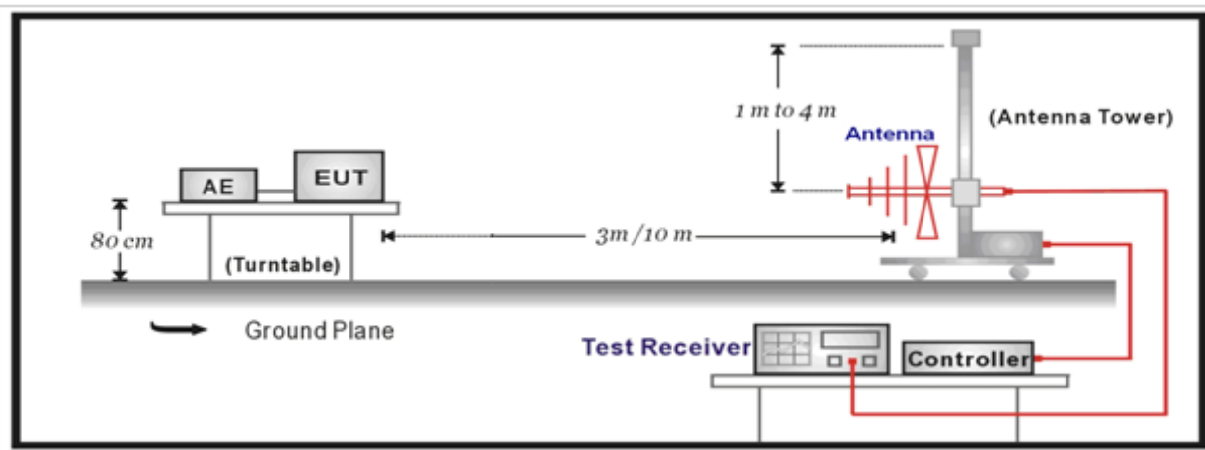

Above 1GHz Test Setup:

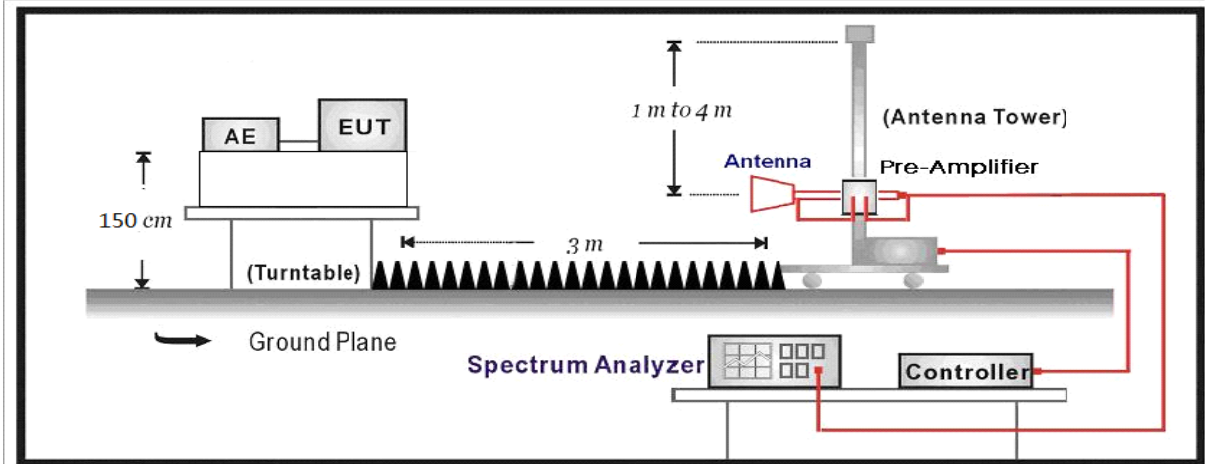

4.3. Limit

For FCC:

Restricted Bands of operation			
Frequency (MHz)	Frequency (MHz)	Frequency (MHz)	Frequency (GHz)
0.090 – 0.110	16.42 – 16.423	399.9 – 410	4.5 – 5.15
0.495 – 0.505	16.69475 – 16.69525	608 – 614	5.35 – 5.46
2.1735 – 2.1905	16.80425 – 16.80475	960 – 1240	7.25 – 7.75
4.125 – 4.128	25.5 – 25.67	1300 – 1427	8.025 – 8.5
4.17725 – 4.17775	37.5 – 38.25	1435 – 1626.5	9.0 – 9.2
4.20725 – 4.20775	73 – 74.6	1645.5 – 1646.5	9.3 – 9.5
6.215 – 6.218	74.8 – 75.2	1660 – 1710	10.6 – 12.7
6.26775 – 6.26825	108 – 121.94	1718.8 – 1722.2	13.25 – 13.4
6.31175 – 6.31225	123 – 138	2200 – 2300	14.47 – 14.5
8.291 – 8.294	149.9 – 150.05	2310 – 2390	15.35 – 16.2
8.362 – 8.366	156.52475 – 156.52525	2483.5 – 2500	17.7 – 21.4
8.37625 – 8.38675	156.7 – 156.9	2690 – 2900	22.01 – 23.12
8.81425 – 8.81475	162.0125 – 167.17	3260 – 3267	23.6 – 24.0
12.29 – 12.293	167.72 – 173.2	3332 – 3339	31.2 – 31.8
12.51975 – 12.52025	240 – 285	3345.8 – 3358	36.43 – 36.5
12.57675 – 12.57725	322 – 335.4	3600 – 4400	
13.36 – 13.41			

For ISED:

Restricted Bands of operation			
Frequency (MHz)	Frequency (MHz)	Frequency (MHz)	Frequency (GHz)
	13.36 - 13.41	960 - 1427	9.0 - 9.2
0.495 - 0.505	16.42 - 16.423	1435 - 1626.5	9.3 - 9.5
2.1735 - 2.1905	16.69475 - 16.69525	1645.5 - 1646.5	10.6 - 12.7
3.020 - 3.026	16.80425 - 16.80475	1660 - 1710	13.25 - 13.4
4.125 - 4.128	25.5 - 25.67	1718.8 - 1722.2	14.47 - 14.5
4.17725 - 4.17775	37.5 - 38.25	2200 - 2300	15.35 - 16.2
4.20725 - 4.20775	73 - 74.6	2310 - 2390	17.7 - 21.4
5.677 - 5.683	74.8 - 75.2	2483.5 - 2500	22.01 - 23.12
6.215 - 6.218	108 - 138	2655 - 2900	23.6 - 24.0
6.26775 - 6.26825	149.9 - 150.05	3260 - 3267	31.2 - 31.8
6.31175 - 6.31225	156.52475 - 156.52525	3332 - 3339	36.43 - 36.5
8.291 - 8.294	156.7 - 156.9	3345.8 - 3358	Above 38.6
8.362 - 8.366	162.0125 - 167.17	3500 - 4400	
8.37625 - 8.38675	167.72 - 173.2	4500 - 5150	
8.41425 - 8.41475	240 - 285	5350 - 5460	
12.29 - 12.293	322 - 335.4	7250 - 7750	
12.51975 - 12.52025	399.9 - 410	8025 - 8500	
12.57675 - 12.57725	608 - 614	--	

Restricted Band Emissions Limit			
Frequency (MHz)	Field strength (μ V/m)	Field strength (dB μ V/m)	Measurement distance (m)
0.009 - 0.49	2400/F(kHz)	48.5 – 13.8	300 _(Note 1)
0.49 - 1.705	24000/F(kHz)	33.8 - 23	30 _(Note 1)
1.705 - 30	30	29.5	30 _(Note 1)
30 - 88	100	40	3 _(Note 2)
88 - 216	150	43.5	3 _(Note 2)
216 - 960	200	46	3 _(Note 2)
Above 960	500	54	3 _(Note 2)



Note 1: At frequencies below 30 MHz, measurements may be performed at a distance closer than that specified in the regulations; however, an attempt should be made to avoid making measurements in the near field. Pending the development of an appropriate measurement procedure for measurements performed below 30 MHz, when performing measurements at a closer distance than specified, the results shall be extrapolated to the specified distance by either making measurements at a minimum of two distances on at least one radial to determine the proper extrapolation factor or by using the square of an inverse linear distance extrapolation factor (40 dB/decade).

Note 2: At frequencies at or above 30 MHz, measurements may be performed at a distance other than what is specified provided: measurements are not made in the near field except where it can be shown that near field measurements are appropriate due to the characteristics of the device; and it can be demonstrated that the signal levels needed to be measured at the distance employed can be detected by the measurement equipment. Measurements shall not be performed at a distance greater than 30 meters unless it can be further demonstrated that measurements at a distance of 30 meters or less are impractical. When performing measurements at a distance other than that specified, the results shall be extrapolated to the specified distance using an extrapolation factor of 20 dB/decade (inverse linear-distance for field strength measurements; inverse-linear-distance-squared for power density measurements).

4.4. Test Procedure

Test Method			
	References Rule	Chapter	Description
<input type="checkbox"/>	ANSI C63.10	11.11	Emissions in non-restricted frequency bands
	<input type="checkbox"/> ANSI C63.10	11.11.2	Reference level measurement
	<input type="checkbox"/> ANSI C63.10	11.11.3	Emission level measurement
<input checked="" type="checkbox"/>	ANSI C63.10	11.12	Emissions in restricted frequency bands
	<input checked="" type="checkbox"/> ANSI C63.10	11.12.1	Radiated emission measurements
	<input checked="" type="checkbox"/> ANSI C63.10	11.12.2.7	Radiated spurious emission test
	<input checked="" type="checkbox"/> ANSI C63.10	6.4	Radiated emissions from unlicensed wireless devices below 30 MHz
	<input checked="" type="checkbox"/> ANSI C63.10	6.5	Radiated emissions from unlicensed wireless devices in the frequency range of 30 MHz to 1000 MHz
	<input checked="" type="checkbox"/> ANSI C63.10	6.6	Radiated emissions from unlicensed wireless devices above 1 GHz
	<input type="checkbox"/> ANSI C63.10	11.12.2.3	Quasi-peak measurement procedure
	<input type="checkbox"/> ANSI C63.10	11.12.2.4	Peak power measurement procedure
	<input type="checkbox"/> ANSI C63.10	11.12.2.5	Average power measurement procedures
	<input type="checkbox"/> ANSI C63.10	11.12.2.5.1	Trace averaging with continuous EUT transmission at full power
	<input type="checkbox"/> ANSI C63.10	11.12.2.5.2	Trace averaging across ON and OFF times of the EUT transmissions followed by duty cycle correction
	<input type="checkbox"/> ANSI C63.10	11.12.2.5.3	Reduced VBW averaging across ON and OFF times of the EUT transmissions with max hold

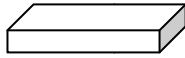
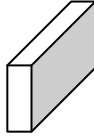
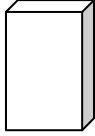
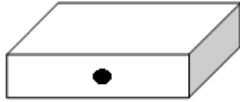
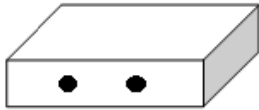
4.5. EUT test Axis definition

Item	Emissions in restricted frequency bands			
Device Category	<input type="checkbox"/>	Fixed point-to-point		
	<input type="checkbox"/>	Emit multiple directional beams, simultaneously or sequentially		
	<input checked="" type="checkbox"/>	Other cases		
Test mode	Mode 1			
Test method	<input checked="" type="checkbox"/>	Radiated		
		X Axis	Y Axis	Z Axis
				
		Worst Axis <input checked="" type="checkbox"/>	Worst Axis <input type="checkbox"/>	Worst Axis <input type="checkbox"/>
	<input type="checkbox"/>	Conducted		
	<input type="checkbox"/>	Chain 0		
				
	<input type="checkbox"/>	Chain 0	Chain 1	
				
	<input type="checkbox"/>	Chain 0	Chain 1	Chain 2
				

4.6. Test Result

Muruta:

Engineer: Tongben	
Site: AC5	Time: 2019/08/22 - 18:50
Limit: FCC_Part15.209_RE(3m)	Margin: 0
Probe: Horn_3117_00167055(1-18GHz)	Polarity: Horizontal
EUT: LED lamp	Power: AC 120V/60Hz
Note: Mode 1:Transmit at 2405MHz by Zigbee	

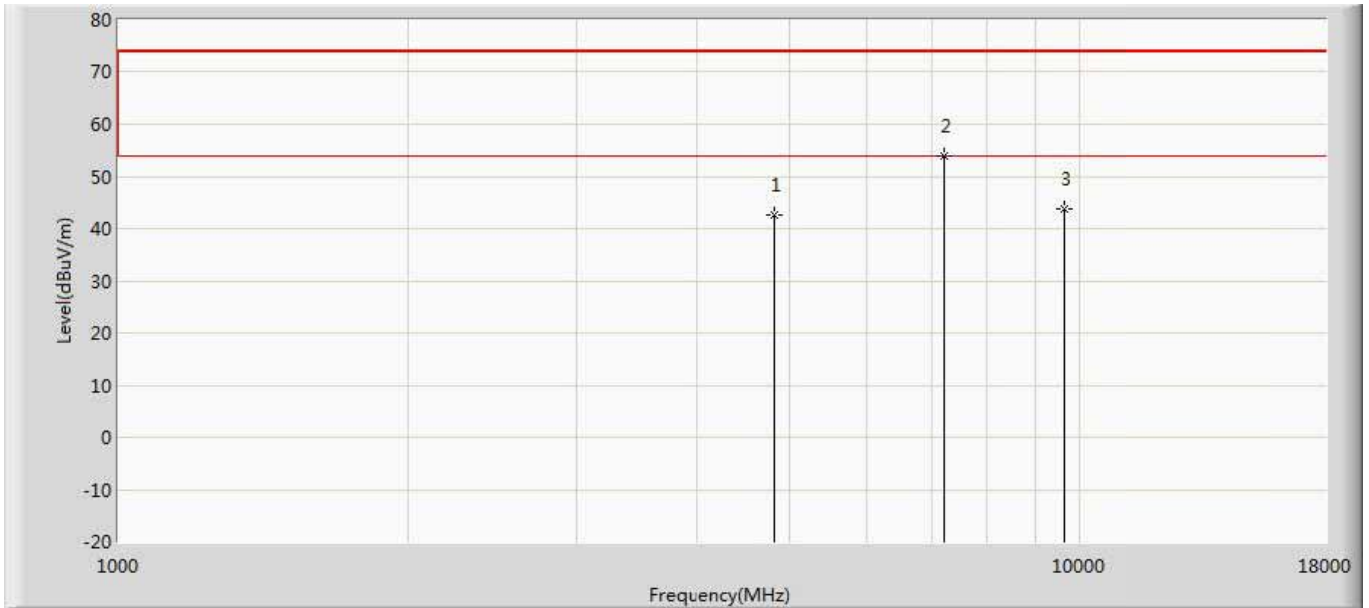

No	Mark	Frequency (MHz)	Measure Level (dBuV/m)	Reading Level (dBuV)	Over Limit (dB)	Limit (dBuV/m)	Factor (dB)	Type
1		4810.000	42.471	37.966	-31.529	74.000	4.505	PK
2	*	7215.000	53.913	46.355	-20.087	74.000	7.557	PK
3		9620.000	43.739	34.499	-30.261	74.000	9.239	PK

Engineer: Tongben	
Site: AC5	Time: 2019/08/22 - 18:50
Limit: FCC_Part15.209_RE(3m)	Margin: 0
Probe: Horn_3117_00167055(1-18GHz)	Polarity: Vertical
EUT: LED lamp	Power: AC 120V/60Hz
Note: Mode 1:Transmit at 2405MHz by Zigbee	

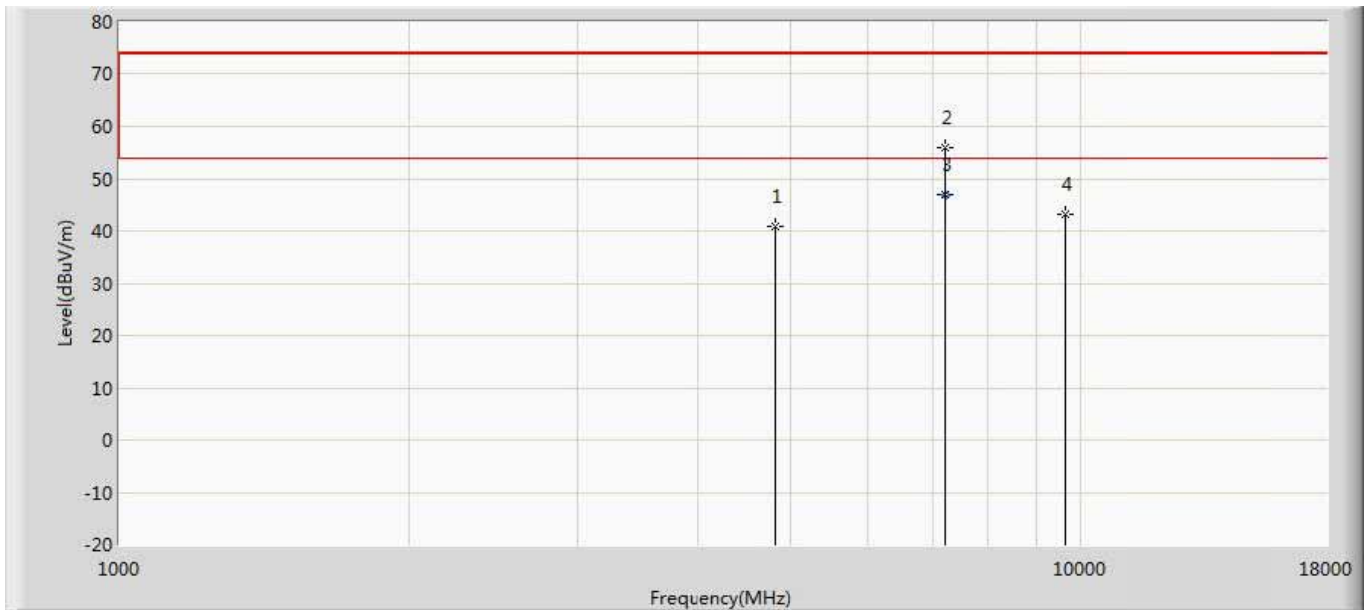

No	Mark	Frequency (MHz)	Measure Level (dBuV/m)	Reading Level (dBuV)	Over Limit (dB)	Limit (dBuV/m)	Factor (dB)	Type
1		4810.000	40.726	36.221	-33.274	74.000	4.505	PK
2		7215.000	55.810	48.252	-18.190	74.000	7.557	PK
3	*	7215.000	47.045	39.487	-6.955	54.000	7.557	AV
4		9620.000	43.149	33.909	-30.851	74.000	9.239	PK

Engineer: Tongben	
Site: AC5	Time: 2019/08/22 - 18:50
Limit: FCC_Part15.209_RE(3m)	Margin: 0
Probe: Horn_3117_00167055(1-18GHz)	Polarity: Horizontal
EUT: LED lamp	Power: AC 120V/60Hz
Note: Mode 1:Transmit at 2440MHz by Zigbee	

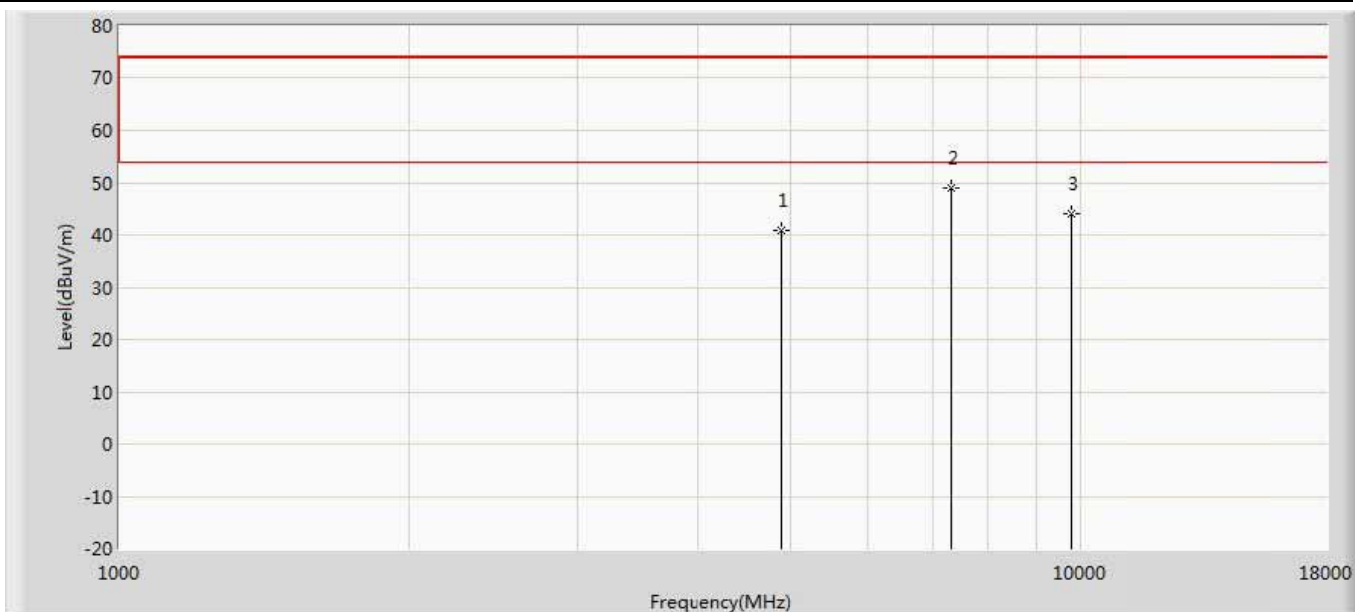

No	Mark	Frequency (MHz)	Measure Level (dBuV/m)	Reading Level (dBuV)	Over Limit (dB)	Limit (dBuV/m)	Factor (dB)	Type
1		4880.000	40.931	36.145	-33.069	74.000	4.786	PK
2	*	7320.000	48.896	41.234	-25.104	74.000	7.663	PK
3		9760.000	44.179	34.319	-29.821	74.000	9.860	PK

Engineer: Tongben	
Site: AC5	Time: 2019/08/22 - 18:50
Limit: FCC_Part15.209_RE(3m)	Margin: 0
Probe: Horn_3117_00167055(1-18GHz)	Polarity: Vertical
EUT: LED lamp	Power: AC 120V/60Hz
Note: Mode 1:Transmit at 2440MHz by Zigbee	

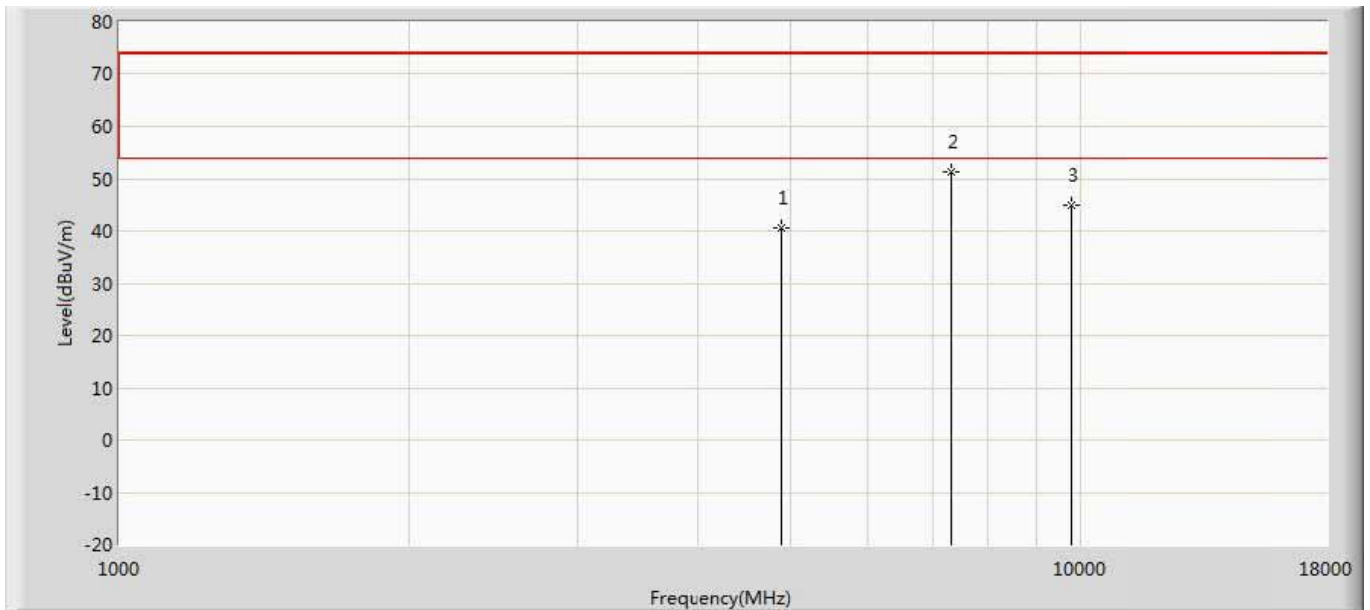

No	Mark	Frequency (MHz)	Measure Level (dBuV/m)	Reading Level (dBuV)	Over Limit (dB)	Limit (dBuV/m)	Factor (dB)	Type
1		4880.000	40.690	35.904	-33.310	74.000	4.786	PK
2	*	7320.000	51.441	43.779	-22.559	74.000	7.663	PK
3		9760.000	44.797	34.937	-29.203	74.000	9.860	PK

Engineer: Tongben	
Site: AC5	Time: 2019/08/22 - 18:50
Limit: FCC_Part15.209_RE(3m)	Margin: 0
Probe: Horn_3117_00167055(1-18GHz)	Polarity: Horizontal
EUT: LED lamp	Power: AC 120V/60Hz
Note: Mode 1:Transmit at 2480MHz by Zigbee	

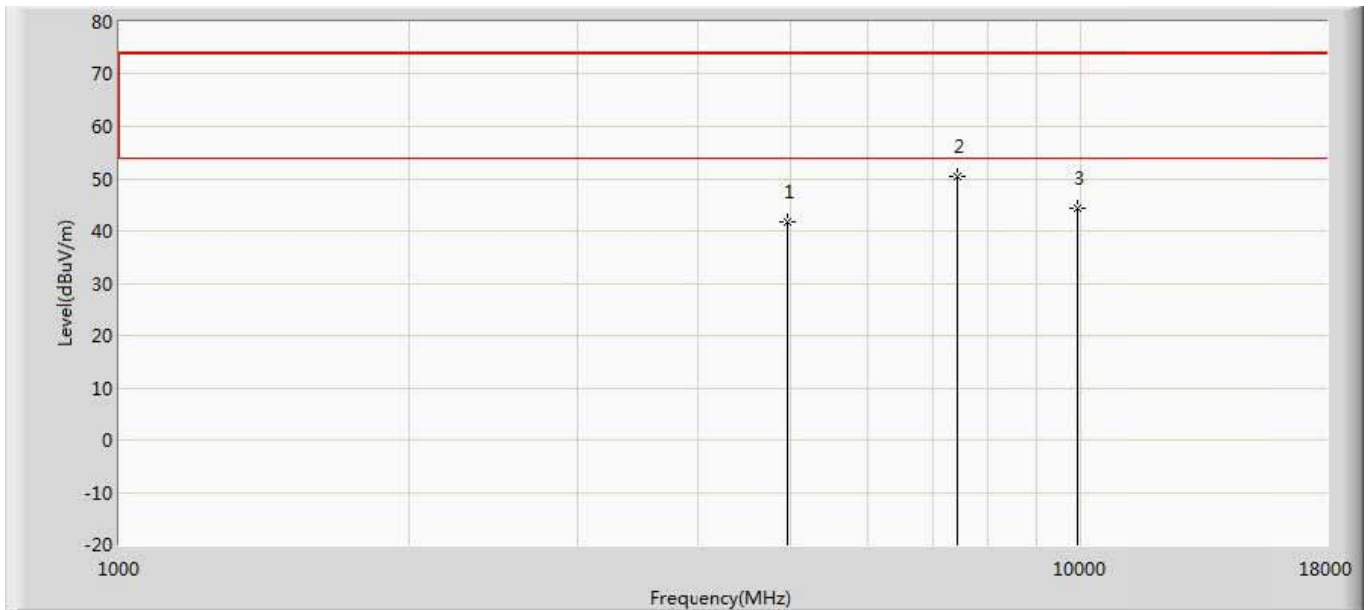

No	Mark	Frequency (MHz)	Measure Level (dBuV/m)	Reading Level (dBuV)	Over Limit (dB)	Limit (dBuV/m)	Factor (dB)	Type
1		4960.000	41.728	36.808	-32.272	74.000	4.920	PK
2	*	7440.000	50.420	42.705	-23.580	74.000	7.715	PK
3		9920.000	44.297	34.350	-29.703	74.000	9.946	PK

Engineer: Tongben	
Site: AC5	Time: 2019/08/22 - 18:50
Limit: FCC_Part15.209_RE(3m)	Margin: 0
Probe: Horn_3117_00167055(1-18GHz)	Polarity: Vertical
EUT: LED lamp	Power: AC 120V/60Hz
Note: Mode 1:Transmit at 2480MHz by Zigbee	

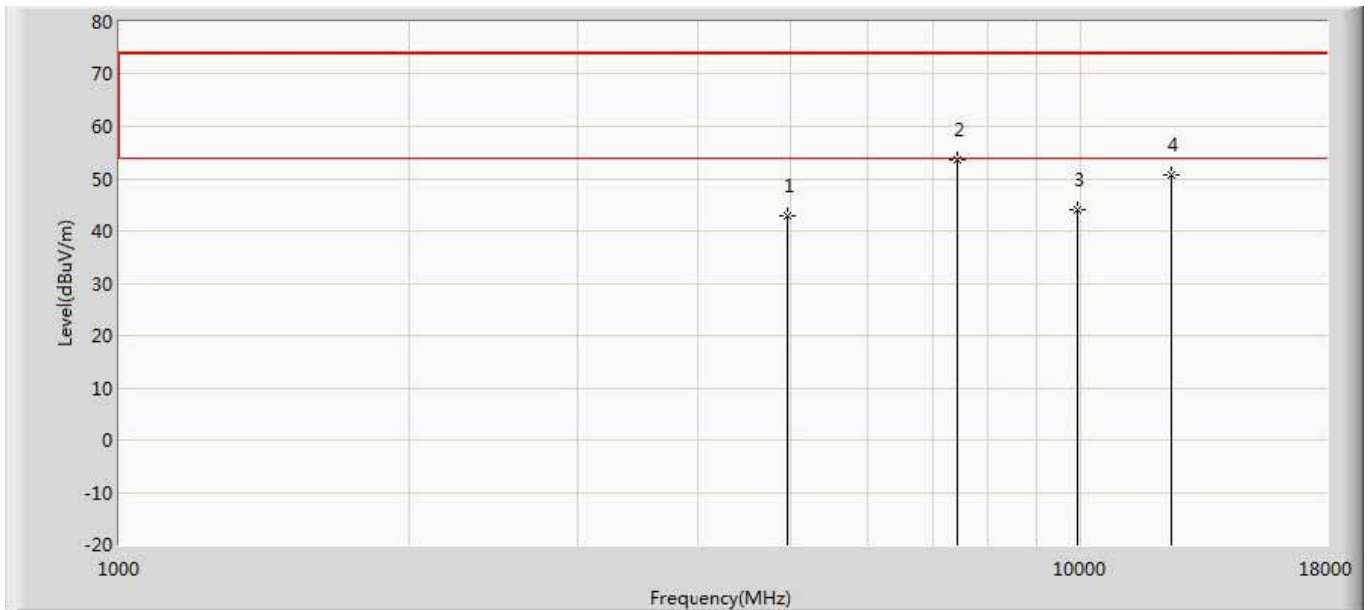

No	Mark	Frequency (MHz)	Measure Level (dBuV/m)	Reading Level (dBuV)	Over Limit (dB)	Limit (dBuV/m)	Factor (dB)	Type
1		4960.000	42.985	38.065	-31.015	74.000	4.920	PK
2	*	7440.000	53.704	45.989	-20.296	74.000	7.715	PK
3		9920.000	44.144	34.197	-29.856	74.000	9.946	PK
4		12400.000	50.804	34.805	-23.196	74.000	15.999	PK

Diodes:

Engineer: Tongben	
Site: AC5	Time: 2019/08/25 - 15:37
Limit: FCC_Part15.209_RE(3m)	Margin: 0
Probe: Horn_3117_00167055(1-18GHz)	Polarity: Horizontal
EUT: LED lamp	Power: AC 120V/60Hz
Note: Mode 1:Transmit at 2405MHz by Zigbee	

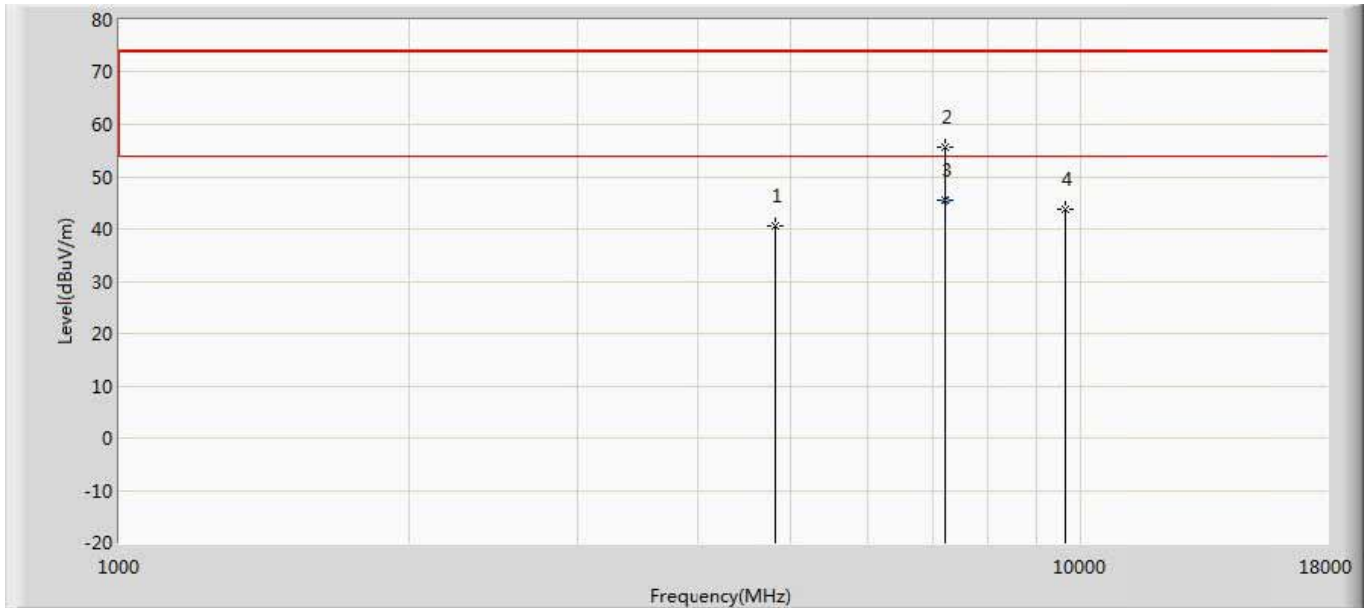

No	Mark	Frequency (MHz)	Measure Level (dBuV/m)	Reading Level (dBuV)	Over Limit (dB)	Limit (dBuV/m)	Factor (dB)	Type
1		4810.000	40.470	35.965	-33.530	74.000	4.505	PK
2		7215.000	55.628	48.070	-18.372	74.000	7.557	PK
3	*	7215.000	45.372	37.814	-8.628	54.000	7.557	AV
4		9620.000	43.862	34.622	-30.138	74.000	9.239	PK

Engineer: Tongben	
Site: AC5	Time: 2019/08/25 - 15:37
Limit: FCC_Part15.209_RE(3m)	Margin: 0
Probe: Horn_3117_00167055(1-18GHz)	Polarity: Vertical
EUT: LED lamp	Power: AC 120V/60Hz
Note: Mode 1:Transmit at 2405MHz by Zigbee	

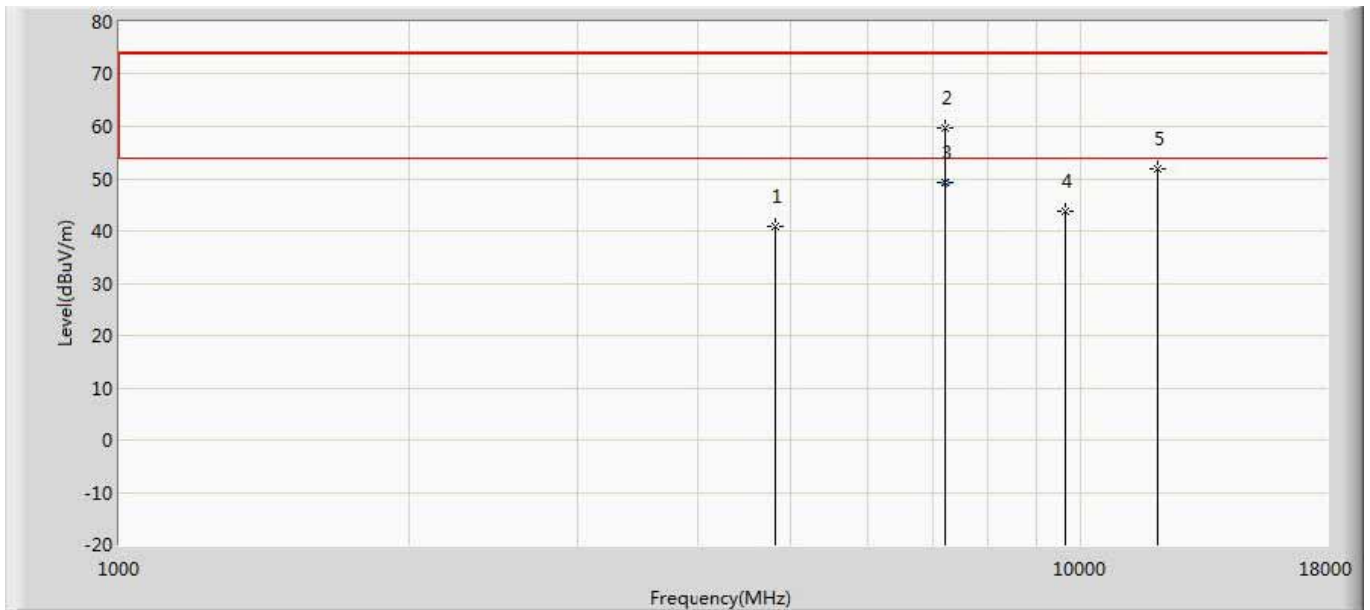

No	Mark	Frequency (MHz)	Measure Level (dBuV/m)	Reading Level (dBuV)	Over Limit (dB)	Limit (dBuV/m)	Factor (dB)	Type
1		4810.000	40.811	36.306	-33.189	74.000	4.505	PK
2		7215.000	59.827	52.269	-14.173	74.000	7.557	PK
3	*	7215.000	49.182	41.624	-4.818	54.000	7.557	AV
4		9620.000	43.668	34.428	-30.332	74.000	9.239	PK
5		12025.000	51.932	37.542	-22.068	74.000	14.390	PK

Engineer: Tongben	
Site: AC5	Time: 2019/08/25 - 15:37
Limit: FCC_Part15.209_RE(3m)	Margin: 0
Probe: Horn_3117_00167055(1-18GHz)	Polarity: Horizontal
EUT: LED lamp	Power: AC 120V/60Hz
Note: Mode 1:Transmit at 2440MHz by Zigbee	

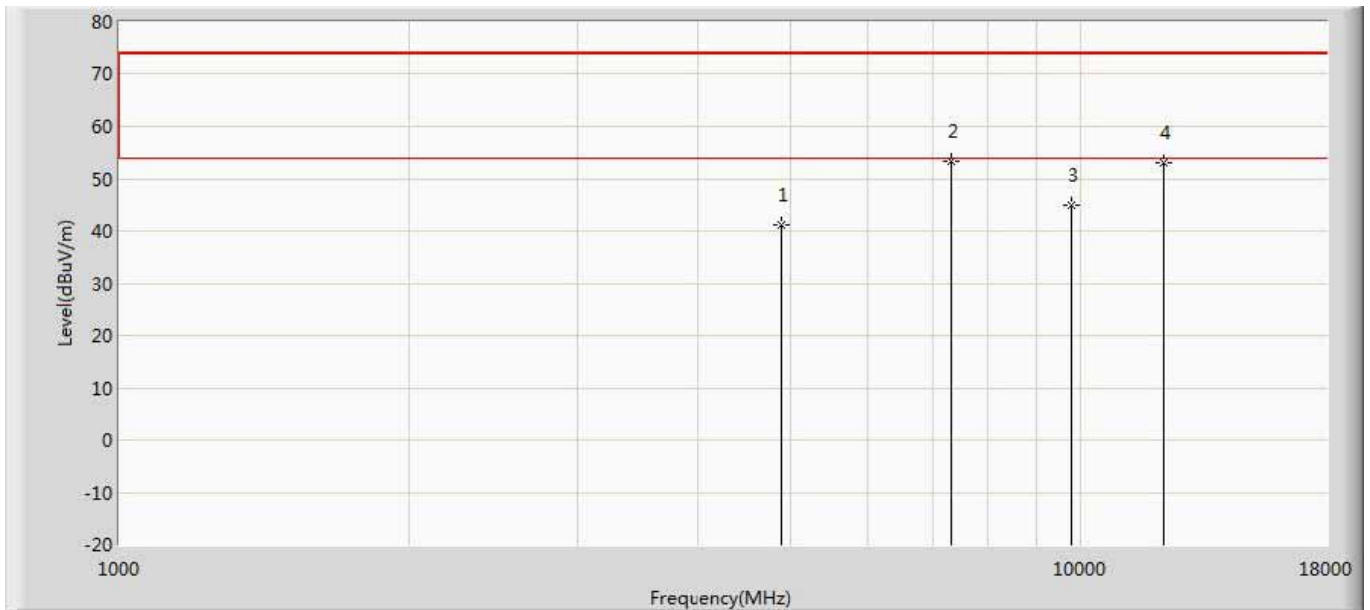

No	Mark	Frequency (MHz)	Measure Level (dBuV/m)	Reading Level (dBuV)	Over Limit (dB)	Limit (dBuV/m)	Factor (dB)	Type
1		4880.000	41.125	36.339	-32.875	74.000	4.786	PK
2	*	7320.000	53.283	45.621	-20.717	74.000	7.663	PK
3		9760.000	44.788	34.928	-29.212	74.000	9.860	PK
4		12200.000	53.037	37.685	-20.963	74.000	15.351	PK

Engineer: Tongben	
Site: AC5	Time: 2019/08/25 - 15:37
Limit: FCC_Part15.209_RE(3m)	Margin: 0
Probe: Horn_3117_00167055(1-18GHz)	Polarity: Vertical
EUT: LED lamp	Power: AC 120V/60Hz
Note: Mode 1:Transmit at 2440MHz by Zigbee	

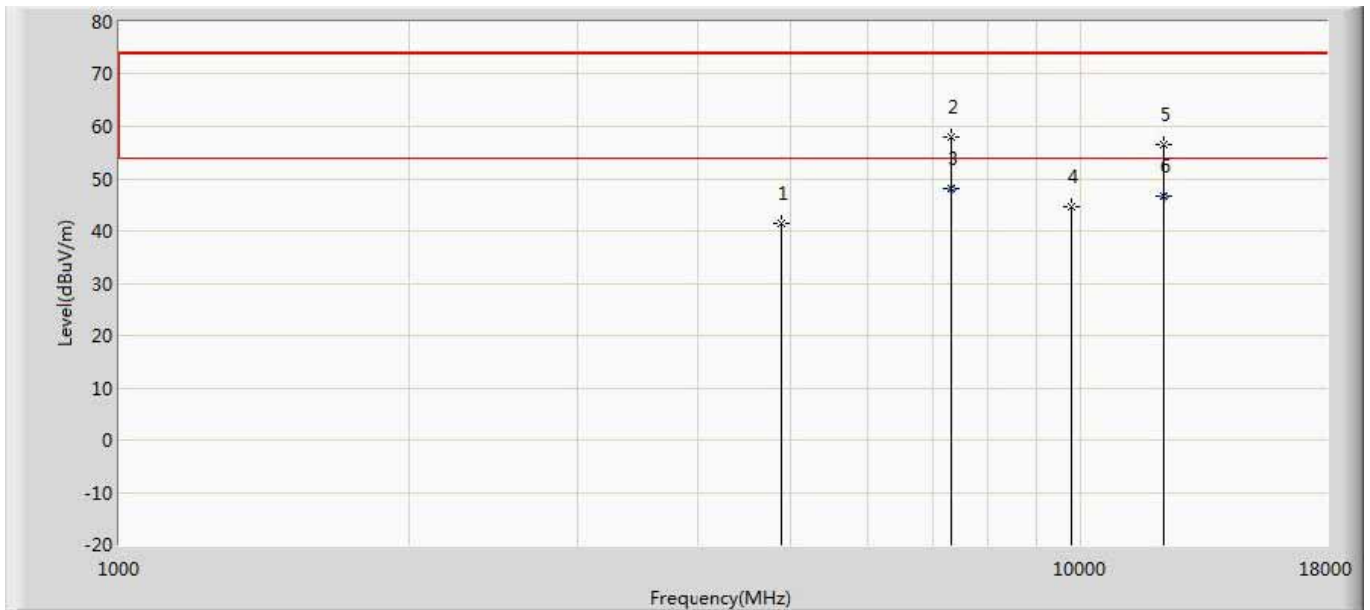

No	Mark	Frequency (MHz)	Measure Level (dBuV/m)	Reading Level (dBuV)	Over Limit (dB)	Limit (dBuV/m)	Factor (dB)	Type
1		4880.000	41.571	36.785	-32.429	74.000	4.786	PK
2		7320.000	57.857	50.195	-16.143	74.000	7.663	PK
3	*	7320.000	48.185	40.523	-5.815	54.000	7.663	AV
4		9760.000	44.601	34.741	-29.399	74.000	9.860	PK
5		12200.000	56.582	41.230	-17.418	74.000	15.351	PK
6		12200.000	46.777	31.425	-7.223	54.000	15.351	AV

Engineer: Tongben	
Site: AC5	Time: 2019/08/25 - 15:37
Limit: FCC_Part15.209_RE(3m)	Margin: 0
Probe: Horn_3117_00167055(1-18GHz)	Polarity: Horizontal
EUT: LED lamp	Power: AC 120V/60Hz
Note: Mode 1:Transmit at 2480MHz by Zigbee	

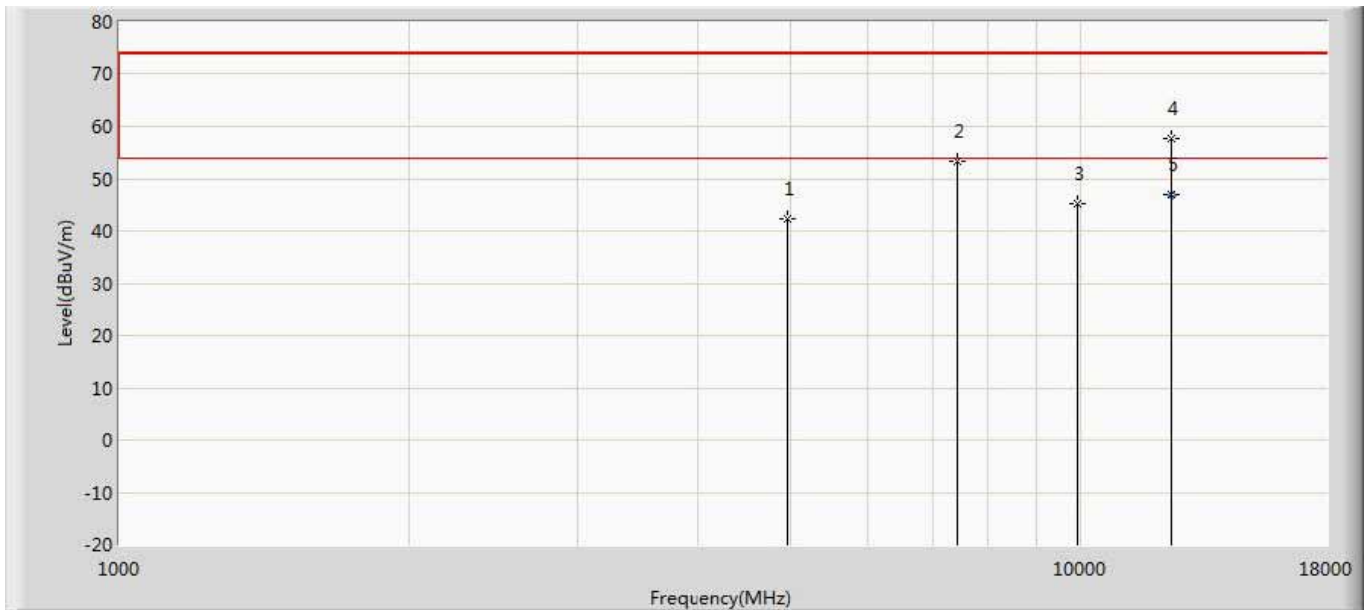

No	Mark	Frequency (MHz)	Measure Level (dBuV/m)	Reading Level (dBuV)	Over Limit (dB)	Limit (dBuV/m)	Factor (dB)	Type
1		4960.000	42.251	37.331	-31.749	74.000	4.920	PK
2		7440.000	53.362	45.647	-20.638	74.000	7.715	PK
3		9920.000	45.183	35.236	-28.817	74.000	9.946	PK
4		12400.000	57.577	41.578	-16.423	74.000	15.999	PK
5	*	12400.000	46.904	30.905	-7.096	54.000	15.999	AV

Engineer: Tongben	
Site: AC5	Time: 2019/08/25 - 15:37
Limit: FCC_Part15.209_RE(3m)	Margin: 0
Probe: Horn_3117_00167055(1-18GHz)	Polarity: Vertical
EUT: LED lamp	Power: AC 120V/60Hz
Note: Mode 1:Transmit at 2480MHz by Zigbee	

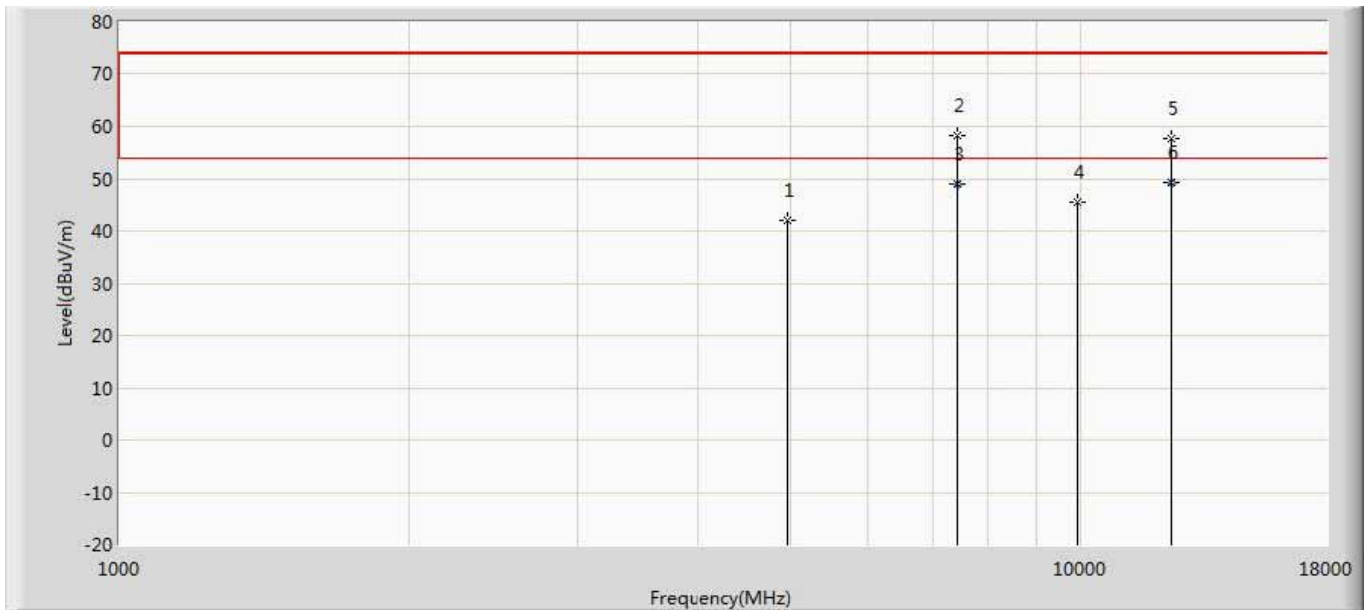

No	Mark	Frequency (MHz)	Measure Level (dBuV/m)	Reading Level (dBuV)	Over Limit (dB)	Limit (dBuV/m)	Factor (dB)	Type
1		4960.000	41.957	37.037	-32.043	74.000	4.920	PK
2		7440.000	58.382	50.667	-15.618	74.000	7.715	PK
3		7440.000	49.012	41.297	-4.988	54.000	7.715	AV
4		9920.000	45.375	35.428	-28.625	74.000	9.946	PK
5		12400.000	57.823	41.824	-16.177	74.000	15.999	PK
6	*	12400.000	49.187	33.188	-4.813	54.000	15.999	AV

The worst case of Radiated Emission below 1GHz:

Engineer: Tim.Cao	
Site: AC2	Time: 2019/08/28 - 19:45
Limit: FCC_Part15.209_RE(3m)_ClassB	Margin: 0
Probe: AC2_3M(30-1000M)	Polarity: Horizontal
EUT: LED Lamp	Power: AC 120V/60Hz
Note: Mode 1:Transmit at Zigbee	

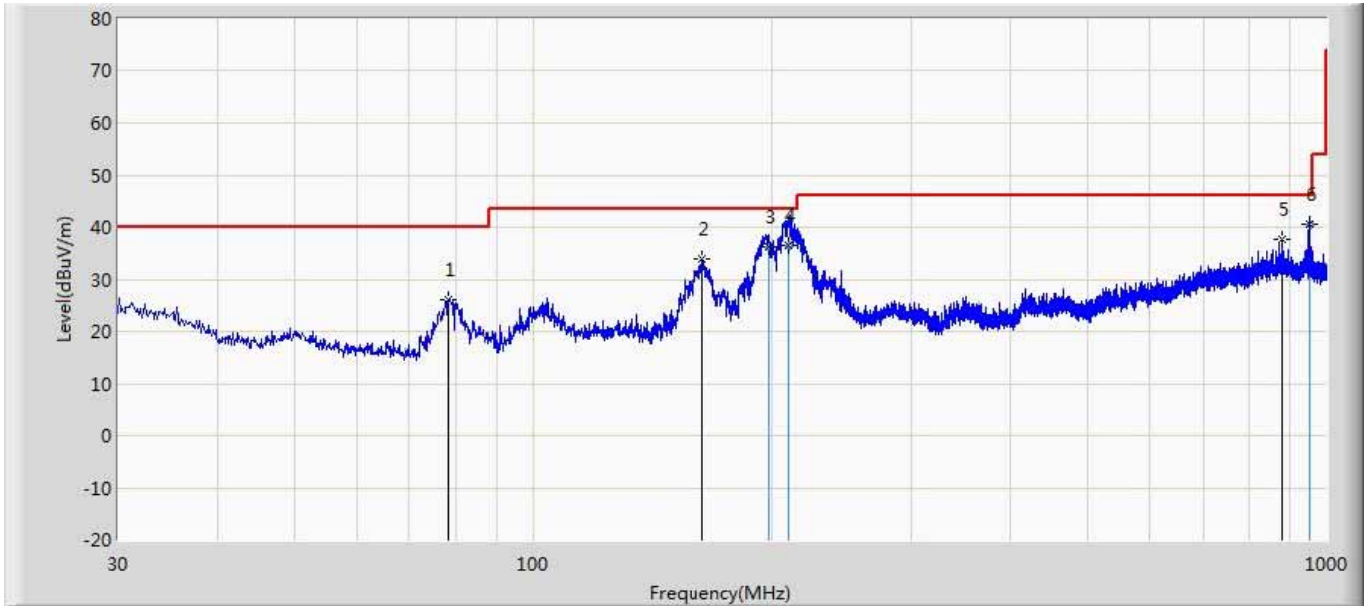

No	Mark	Frequency (MHz)	Measure Level (dBuV/m)	Reading Level (dBuV)	Over Limit (dB)	Limit (dBuV/m)	Factor (dB)	Ant Pos (cm)	Table Pos (deg)	Type
1		78.500	26.146	11.457	-13.854	40.000	14.689	100	126	PK
2		163.739	33.820	14.349	-9.680	43.500	19.471	100	46	PK
3		198.053	36.238	18.428	-7.262	43.500	17.811	100	332	QP
4		210.299	36.625	19.545	-6.875	43.500	17.080	100	217	QP
5		879.599	37.753	4.280	-8.247	46.000	33.473	100	306	PK
6	*	953.682	40.470	7.195	-5.530	46.000	33.275	100	188	QP

Note:

1. All Readings below 1GHz are Quasi-Peak, above are performed with peak and/or average measurements as necessary.
2. " * ", means this data is the worst emission level.
3. Measurement Level = Reading Level + Factor(Probe+Cable-Amp).

Engineer: Tim.Cao	
Site: AC2	Time: 2019/08/28 - 19:47
Limit: FCC_Part15.209_RE(3m)_ClassB	Margin: 0
Probe: AC2_3M(30-1000M)	Polarity: Vertical
EUT: LED Lamp	Power: AC 120V/60Hz
Note: Mode 1:Transmit at Zigbee	

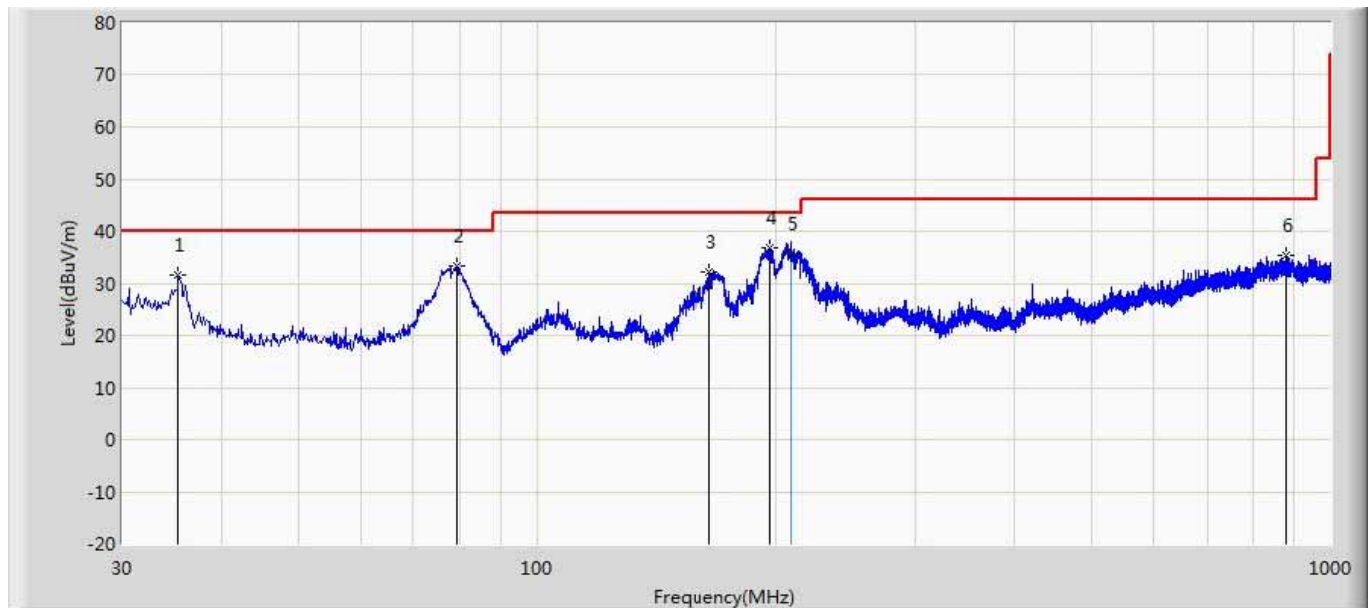

No	Mark	Frequency (MHz)	Measure Level (dBuV/m)	Reading Level (dBuV)	Over Limit (dB)	Limit (dBuV/m)	Factor (dB)	Ant Pos (cm)	Table Pos (deg)	Type
1		35.335	31.582	8.953	-8.418	40.000	22.629	100	207	PK
2	*	79.349	33.477	18.644	-6.523	40.000	14.833	100	326	PK
3		164.830	32.111	12.422	-11.389	43.500	19.689	100	235	PK
4		196.719	36.755	13.992	-6.745	43.500	22.764	100	57	PK
5		208.844	35.736	12.296	-7.764	43.500	23.440	100	112	QP
6		879.599	35.436	1.963	-10.564	46.000	33.473	100	206	PK

Note:

1. All Readings below 1GHz are Quasi-Peak, above are performed with peak and/or average measurements as necessary.
2. " * ", means this data is the worst emission level.
3. Measurement Level = Reading Level + Factor(Probe+Cable-Amp).

Engineer: Tim.Cao	
Site: AC2	Time: 2019/08/28 - 19:49
Limit: FCC_Part15.209_RE(3m)_ClassB	Margin: 0
Probe: AC2_3M(30-1000M)	Polarity: Vertical
EUT: LED Lamp	Power: AC 120V/60Hz
Note: Mode 1:Transmit at Zigbee	

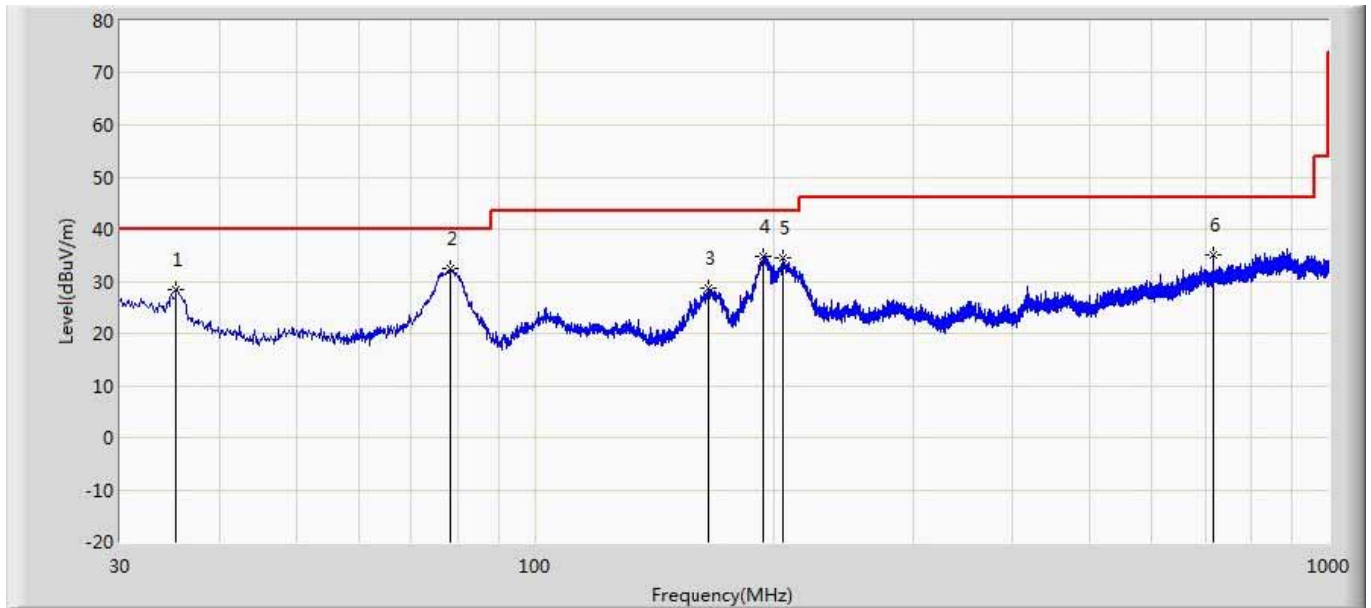

No	Mark	Frequency (MHz)	Measure Level (dBuV/m)	Reading Level (dBuV)	Over Limit (dB)	Limit (dBuV/m)	Factor (dB)	Ant Pos (cm)	Table Pos (deg)	Type
1		35.335	28.439	5.810	-11.561	40.000	22.629	100	168	PK
2	*	78.500	32.447	17.758	-7.553	40.000	14.689	100	84	PK
3		165.800	28.797	9.173	-14.703	43.500	19.624	100	336	PK
4		194.294	34.816	12.662	-8.684	43.500	22.154	100	288	PK
5		205.327	34.412	10.832	-9.088	43.500	23.581	100	175	PK
6		716.275	34.991	4.634	-11.009	46.000	30.357	100	237	PK

Note:

1. All Readings below 1GHz are Quasi-Peak, above are performed with peak and/or average measurements as necessary.
2. " * ", means this data is the worst emission level.
3. Measurement Level = Reading Level + Factor(Probe+Cable-Amp).

Engineer: Tim.Cao	
Site: AC2	Time: 2019/08/28 - 19:55
Limit: FCC_Part15.209_RE(3m)_ClassB	Margin: 0
Probe: AC2_3M(30-1000M)	Polarity: Horizontal
EUT: LED Lamp	Power: AC 120V/60Hz
Note: Mode 1:Transmit at Zigbee	

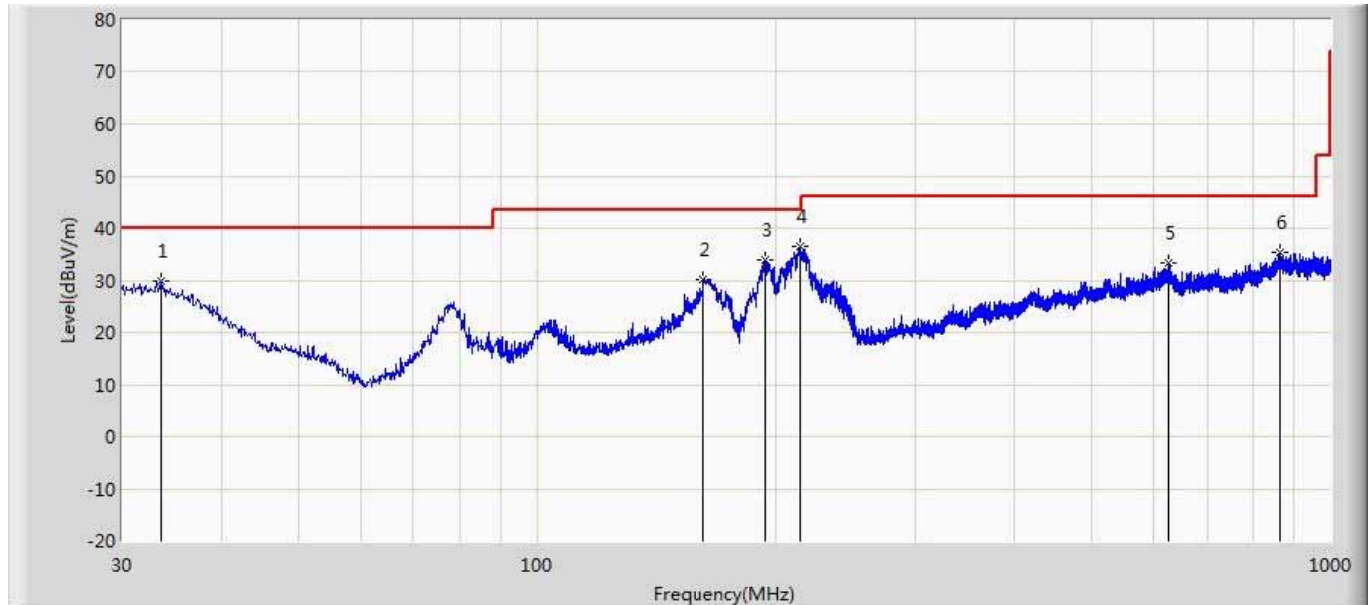

No	Mark	Frequency (MHz)	Measure Level (dBuV/m)	Reading Level (dBuV)	Over Limit (dB)	Limit (dBuV/m)	Factor (dB)	Ant Pos (cm)	Table Pos (deg)	Type
1		33.638	29.829	2.466	-10.171	40.000	27.363	100	159	PK
2		162.526	30.190	12.750	-13.310	43.500	17.440	100	44	PK
3		194.536	34.051	16.464	-9.449	43.500	17.587	100	166	PK
4	*	214.542	36.523	19.423	-6.977	43.500	17.099	100	258	PK
5		625.823	33.337	2.685	-12.663	46.000	30.653	100	179	PK
6		865.412	35.332	2.350	-10.668	46.000	32.982	100	216	PK

Note:

1. All Readings below 1GHz are Quasi-Peak, above are performed with peak and/or average measurements as necessary.
2. " * ", means this data is the worst emission level.
3. Measurement Level = Reading Level + Factor(Probe+Cable-Amp).

5. Emissions in non-restricted frequency bands

5.1. Test Equipment

Emissions in non-restricted frequency bands / TR-8					
Instrument	Manufacturer	Type No.	Serial No.	Cal. Date	Cal. Due Date
Spectrum Analyzer	Agilent	N9010A	MY48030494	2019.02.04	2020.02.03
EXA Spectrum Analyzer	Keysight	N9010A	MY55370495	2019.04.09	2020.04.08
MXA Signal Analyzer	Keysight	N9020A	MY56060147	2019.04.09	2020.04.08
Temperature/Humidity Meter	zhichen	ZC1-2	TR8-TH	2019.04.10	2020.04.09

Note: All equipments are calibrated with traceable calibrations. Each calibration is traceable to the national or international standards.

5.2. Test Setup

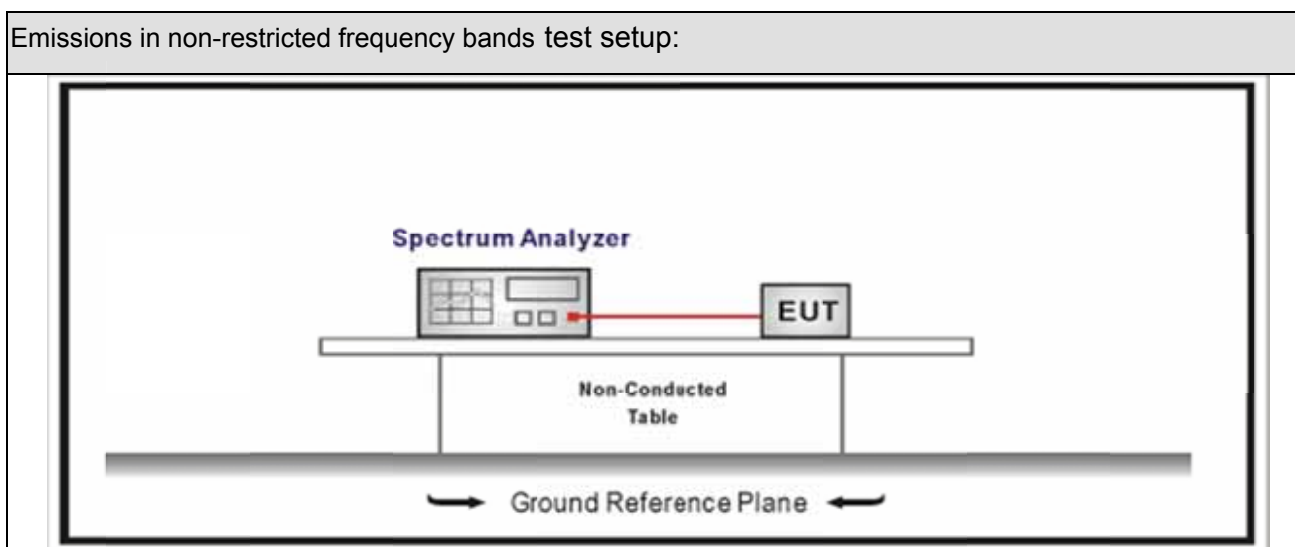



5.3. Limit

Un-Restricted Band Emissions Limit	
RF Output power (Detection methods)	Limit(dB)
RF Output power(Average detector)	30c(Note1)
RF Output power(PK detector)	20c(Note2)
<p>Note 1: If maximum conducted (average) output power was used to demonstrate compliance as described in 9.2, then the peak power in any 100 kHz bandwidth outside of the authorized frequency band shall be attenuated by at least 30 dB relative to the maximum in-band peak PSD level in 100 kHz (i.e., 30 dBc).</p> <p>Note 2: If the maximum peak conducted output power procedure was used, then the peak output power measured in any 100 kHz bandwidth outside of the authorized frequency band shall be attenuated by at least 20 dB relative to the maximum in-band peak PSD level in 100 kHz (i.e., 20 dBc).</p>	

5.4. Test Procedure

Test Method			
	References Rule	Chapter	Description
<input checked="" type="checkbox"/>	ANSI C63.10	11.11	Emissions in non-restricted frequency bands
	<input checked="" type="checkbox"/> ANSI C63.10	11.11.2	Reference level measurement
	<input checked="" type="checkbox"/> ANSI C63.10	11.11.3	Emission level measurement
<input type="checkbox"/>	ANSI C63.10	11.12	Emissions in restricted frequency bands
	<input type="checkbox"/> ANSI C63.10	11.12.1	Radiated emission measurements
	<input type="checkbox"/> ANSI C63.10	11.12.2.7	Radiated spurious emission test
<input type="checkbox"/>	ANSI C63.10	6.4	Radiated emissions from unlicensed wireless devices below 30 MHz
<input type="checkbox"/>	ANSI C63.10	6.5	Radiated emissions from unlicensed wireless devices in the frequency range of 30 MHz to 1000 MHz
<input type="checkbox"/>	ANSI C63.10	6.6	Radiated emissions from unlicensed wireless devices above 1 GHz
	<input type="checkbox"/> ANSI C63.10	11.12.2	Antenna-port conducted measurements
	<input type="checkbox"/> ANSI C63.10	11.12.2.3	Quasi-peak measurement procedure
	<input type="checkbox"/> ANSI C63.10	11.12.2.4	Peak power measurement procedure
	<input type="checkbox"/> ANSI C63.10	11.12.2.5	Average power measurement procedures
	<input type="checkbox"/> ANSI C63.10	11.12.2.5.1	Trace averaging with continuous EUT transmission at full power
	<input type="checkbox"/> ANSI C63.10	11.12.2.5.2	Trace averaging across ON and OFF times of the EUT transmissions followed by duty cycle correction
	<input type="checkbox"/> ANSI C63.10	11.12.2.5.3	Reduced VBW averaging across ON and OFF times of the EUT transmissions with max hold

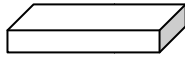
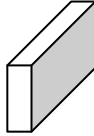
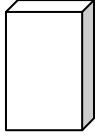
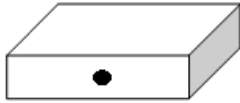
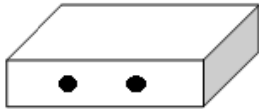
5.5. EUT test Axis definition

Item	Emissions in non-restricted frequency bands			
Device Category	<input type="checkbox"/>	Fixed point-to-point		
	<input type="checkbox"/>	Emit multiple directional beams, simultaneously or sequentially		
	<input checked="" type="checkbox"/>	Other cases		
Test mode	Mode 1			
Test method	<input type="checkbox"/>	Radiated		
		X Axis	Y Axis	Z Axis
				
		Worst Axis <input type="checkbox"/>	Worst Axis <input type="checkbox"/>	Worst Axis <input type="checkbox"/>
	<input checked="" type="checkbox"/>	Conducted		
	<input checked="" type="checkbox"/>	Chain 0		
				
	<input type="checkbox"/>	Chain 0	Chain 1	
				
		Worst Chain <input type="checkbox"/>	Worst Chain <input type="checkbox"/>	
	<input type="checkbox"/>	Chain 0	Chain 1	Chain 2
				
	Worst Chain <input type="checkbox"/>	Worst Chain <input type="checkbox"/>	Worst Chain <input type="checkbox"/>	

5.6. Test Result

Product Name	: LED lamp	Power	: AC 120V/60Hz
Test Mode	: Mode 1: Transmit	Test Site	: TR-8
Test Date	: 2019.08.10		

Mode	Channel	Test Frequency (MHz)	In-Band PSD[a] (dBm/100kHz)	Frequency (MHz)	Out-Band PSD[b] (dBm/100kHz)	[a]-[b] (dB)	Limit (dB)	Result
1	11	2405	5.981	2400.00	-46.193	52.174	>20	Pass
1	26	2480	6.338	2500.00	-54.120	60.458	>20	Pass

Note: The worst case of Emissions in non-restricted frequency bands as below:

Mode 1 CH11 (2405MHz)

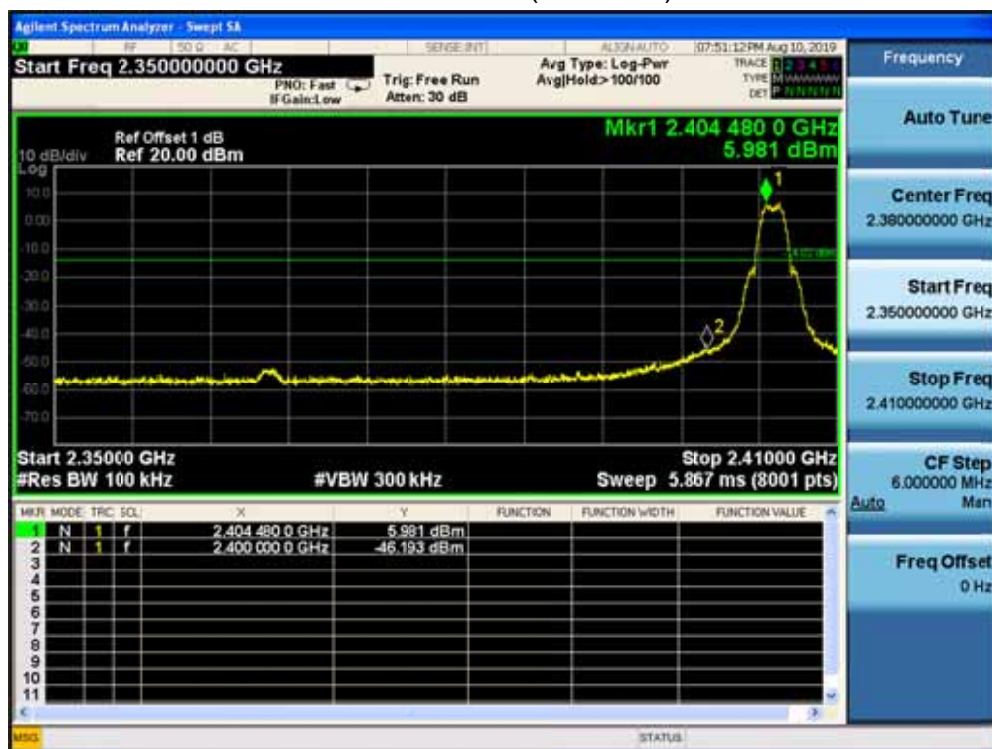

6. Radiated Emission Band Edge

6.1. Test Equipment

Radiated Emission Band Edge / AC-5					
Instrument	Manufacturer	Type No.	Serial No.	Cal. Date	Cal. Due Date
EMI Receiver	Agilent	N9038A	MY51210196	2019.07.16	2020.07.15
Pre-Amplifier	Miteq	NSP1800-25	1364185	2019.05.03	2020.05.02
DRG Horn Antenna	ETS-Lindgren	3117	00167055	2019.07.12	2020.07.11
Broad-Band Horn Antenna	Schwarzbeck	BBHA9170	294	2018.09.18	2019.09.17
Coaxial Cable	Huber+Suhner	SUCOFLEX 106	AC5-C1	2019.02.28	2020.02.27
Coaxial Cable	Huber+Suhner	SUCOFLEX 106	AC5-C2	2019.02.28	2020.02.27
Temperature/Humidity Meter	Zhichen	ZC1-2	AC5-TH	2019.01.05	2020.01.04

6.2. Test Setup

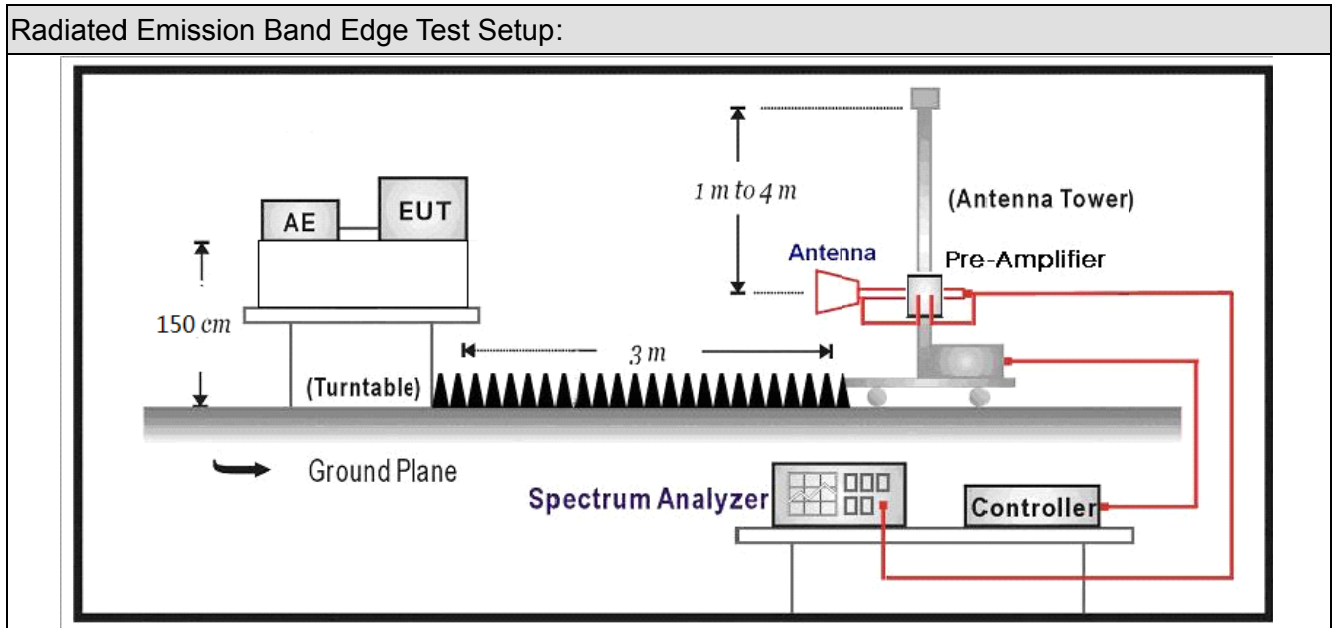

6.3. Limit



Band edge Limit				
Frequency bands (MHz)	Detector	Limit (dB μ V/m)	RBW (MHz)	Distance (m)
2310-2390	PK	74	1	3
2483.5-2500	AV	54	1	3

Note: The field strength of emissions appearing within these frequency bands shall not exceed the limits.

6.4. Test Procedure

Test Method			
	References Rule	Chapter	Description
<input checked="" type="checkbox"/>	ANSI C63.10	6.10	Band-edge testing
	<input checked="" type="checkbox"/> ANSI C63.10	6.10.5	Restricted-band band-edge measurements
	<input type="checkbox"/> ANSI C63.10	6.10.6	Marker-delta method
<input checked="" type="checkbox"/>	ANSI C63.10	11.12	Emissions in restricted frequency bands
	<input checked="" type="checkbox"/> ANSI C63.10	11.12.1	Radiated emission measurements
	<input checked="" type="checkbox"/> ANSI C63.10	11.12.2.7	Radiated spurious emission test
<input type="checkbox"/>	ANSI C63.10	6.4	Radiated emissions from unlicensed wireless devices below 30 MHz
<input type="checkbox"/>	ANSI C63.10	6.5	Radiated emissions from unlicensed wireless devices in the frequency range of 30 MHz to 1000 MHz
<input checked="" type="checkbox"/>	ANSI C63.10	6.6	Radiated emissions from unlicensed wireless devices above 1 GHz
	<input type="checkbox"/> ANSI C63.10	11.12.2.3	Quasi-peak measurement procedure
	<input type="checkbox"/> ANSI C63.10	11.12.2.4	Peak power measurement procedure
	<input type="checkbox"/> ANSI C63.10	11.12.2.5	Average power measurement procedures
	<input type="checkbox"/> ANSI C63.10	11.12.2.5.1	Trace averaging with continuous EUT transmission at full power
	<input type="checkbox"/> ANSI C63.10	11.12.2.5.2	Trace averaging across ON and OFF times of the EUT transmissions followed by duty cycle correction
	<input type="checkbox"/> ANSI C63.10	11.12.2.5.3	Reduced VBW averaging across ON and OFF times of the EUT transmissions with max hold

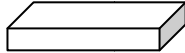
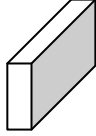
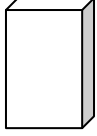
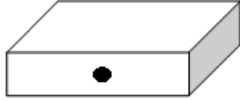
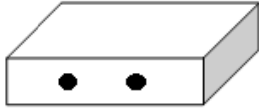
6.5. EUT test definition

Item	Radiated Emission Band Edge			
Device Category	<input type="checkbox"/>	Fixed point-to-point		
	<input type="checkbox"/>	Emit multiple directional beams, simultaneously or sequentially		
	<input checked="" type="checkbox"/>	Other cases		
Test mode	Mode 1			
Test method	<input checked="" type="checkbox"/>	Radiated		
		X Axis	Y Axis	Z Axis
				
		Worst Axis <input checked="" type="checkbox"/>	Worst Axis <input type="checkbox"/>	Worst Axis <input type="checkbox"/>
	<input type="checkbox"/>	Conducted		
	<input type="checkbox"/>	Chain 0		
				
	<input type="checkbox"/>	Chain 0	Chain 1	
				
	<input type="checkbox"/>	Chain 0	Chain 1	Chain 2
				

6.6. Duty Cycle

Test Mode	Tx On (ms)	Tx Off (ms)	Reduced VBW (Hz)	Tx On + Tx Off (ms)	Duty Cycle
Zigbee	N/A	N/A	10	N/A	100%

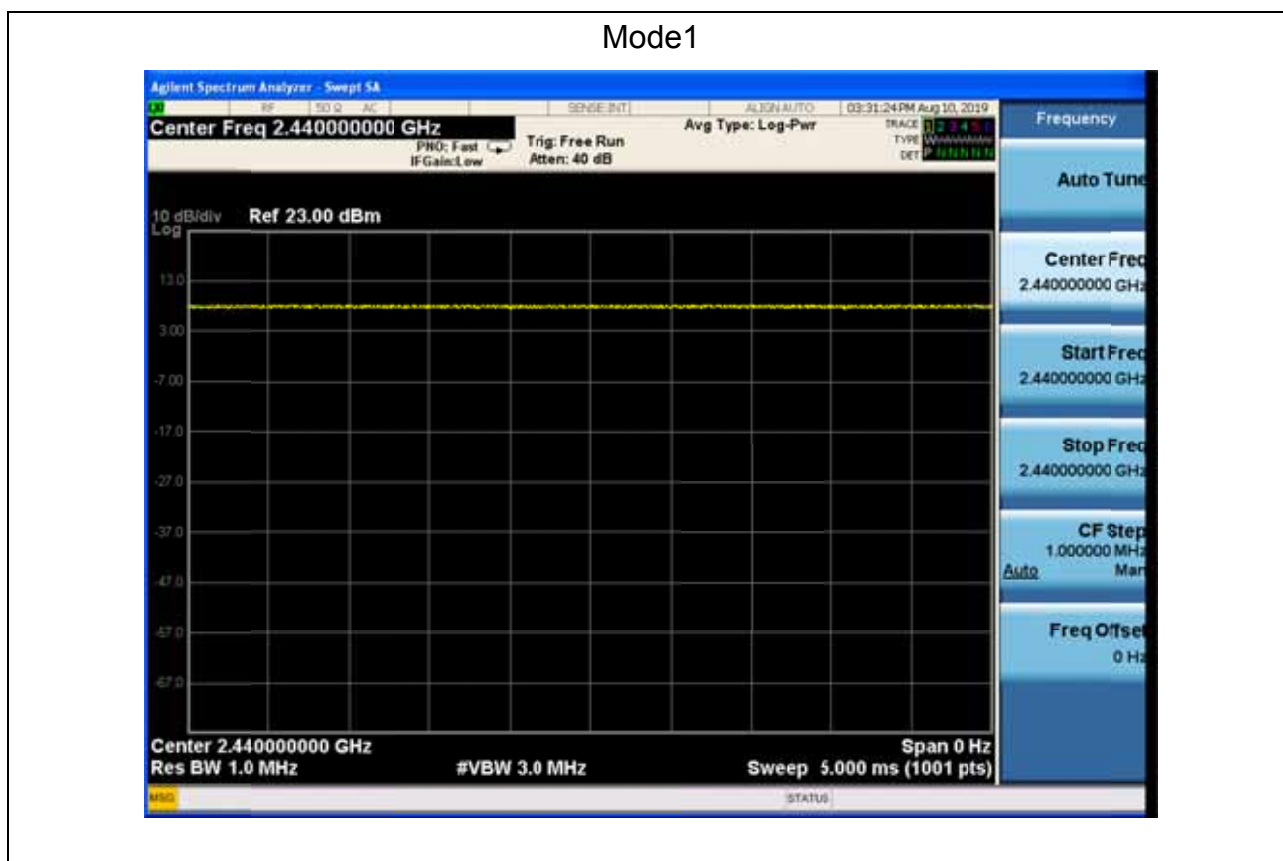

6.7 Test Result

Muruta:

Engineer: Tongben	
Site: AC5	Time: 2019/08/12 - 10:04
Limit: FCC_Part15.209_RE(3m)	Margin: 0
Probe: Horn_3117_00167055(1-18GHz)	Polarity: Horizontal
EUT: LED lamp	Power: AC 120V/60Hz
Note: Mode 1:Transmit at 2405MHz by Zigbee	

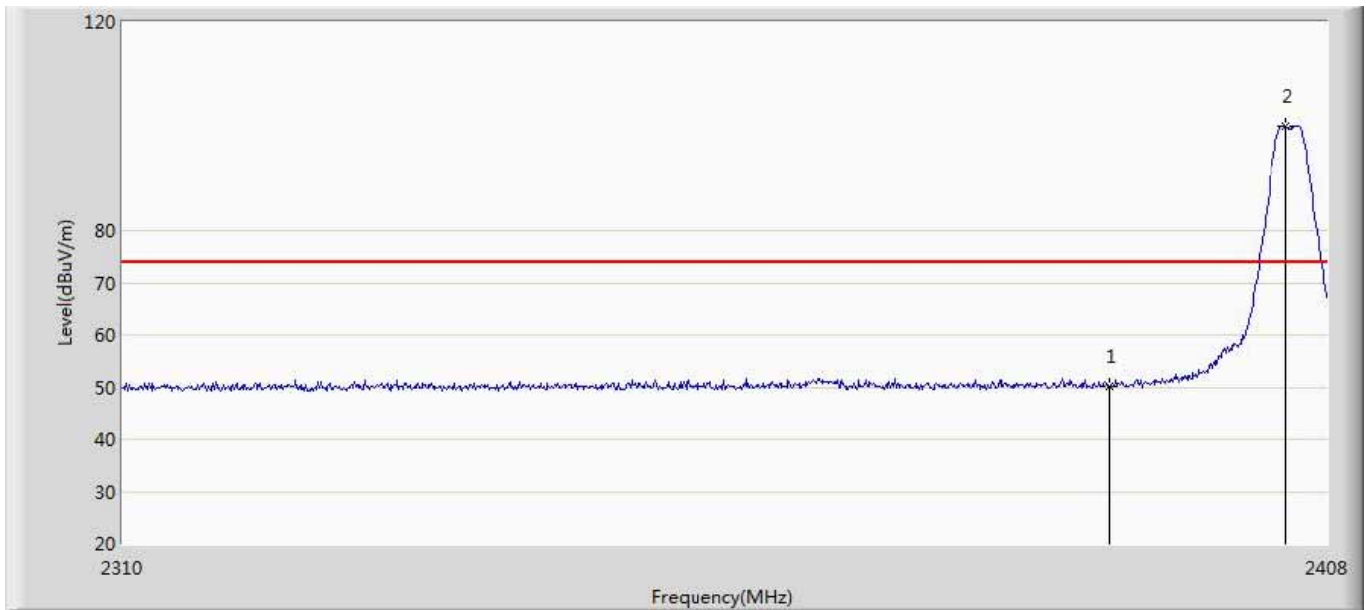

No	Mark	Frequency (MHz)	Measure Level (dBuV/m)	Reading Level (dBuV)	Over Limit (dB)	Limit (dBuV/m)	Factor (dB)	Type
1		2390.000	50.175	14.493	-23.825	74.000	35.682	PK
2	*	2404.570	100.070	64.350	N/A	N/A	35.719	PK

Engineer: Tongben	
Site: AC5	Time: 2019/08/22 - 18:15
Limit: FCC_Part15.209_RE(3m)	Margin: 0
Probe: Horn_3117_00167055(1-18GHz)	Polarity: Vertical
EUT: LED lamp	Power: AC 120V/60Hz
Note: Mode 1:Transmit at 2405MHz by Zigbee	

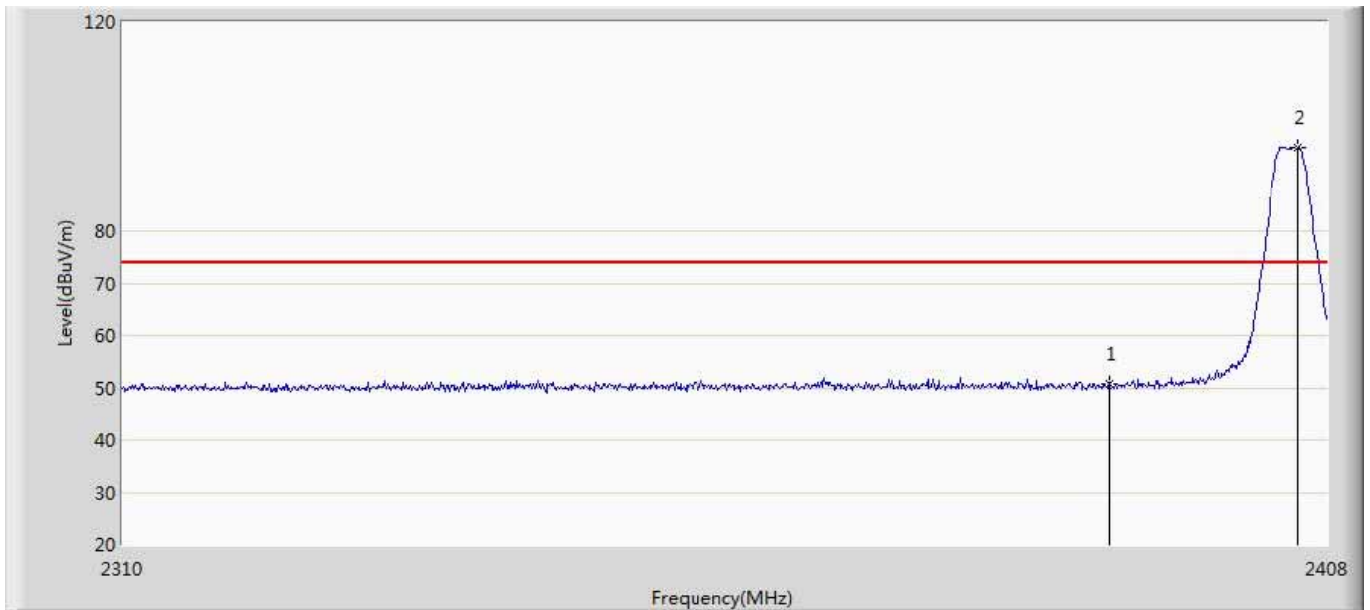

No	Mark	Frequency (MHz)	Measure Level (dBuV/m)	Reading Level (dBuV)	Over Limit (dB)	Limit (dBuV/m)	Factor (dB)	Type
1		2390.000	50.865	15.183	-23.135	74.000	35.682	PK
2	*	2405.648	96.080	60.357	N/A	N/A	35.723	PK

Engineer: Tongben	
Site: AC5	Time: 2019/08/22 - 18:18
Limit: FCC_Part15.209_RE(3m)	Margin: 0
Probe: Horn_3117_00167055(1-18GHz)	Polarity: Horizontal
EUT: LED lamp	Power: AC 120V/60Hz
Note: Mode 1:Transmit at 2405MHz by Zigbee	

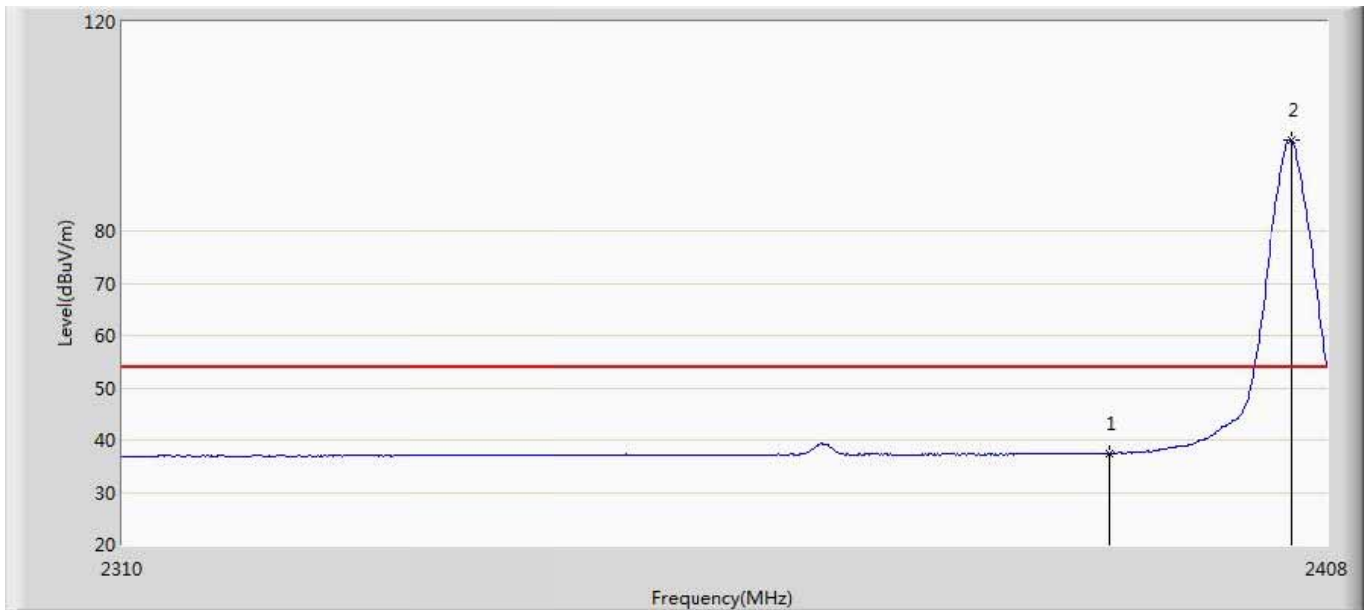

No	Mark	Frequency (MHz)	Measure Level (dBuV/m)	Reading Level (dBuV)	Over Limit (dB)	Limit (dBuV/m)	Factor (dB)	Type
1		2390.000	37.450	1.768	-16.550	54.000	35.682	AV
2	*	2405.158	97.264	61.543	N/A	N/A	35.721	AV

Engineer: Tongben	
Site: AC5	Time: 2019/08/22 - 18:20
Limit: FCC_Part15.209_RE(3m)	Margin: 0
Probe: Horn_3117_00167055(1-18GHz)	Polarity: Vertical
EUT: LED lamp	Power: AC 120V/60Hz
Note: Mode 1:Transmit at 2405MHz by Zigbee	

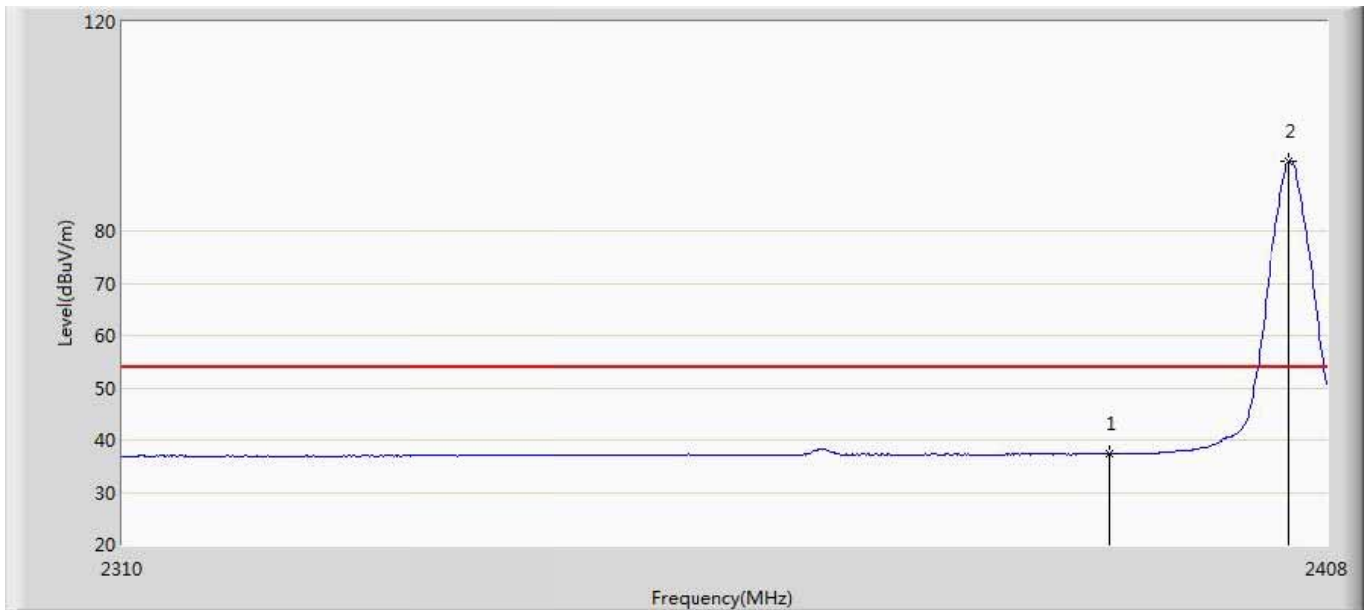

No	Mark	Frequency (MHz)	Measure Level (dBuV/m)	Reading Level (dBuV)	Over Limit (dB)	Limit (dBuV/m)	Factor (dB)	Type
1		2390.000	37.292	1.610	-16.708	54.000	35.682	AV
2	*	2404.864	93.286	57.566	N/A	N/A	35.721	AV

Engineer: Tongben	
Site: AC5	Time: 2019/08/22 - 18:36
Limit: FCC_Part15.209_RE(3m)	Margin: 0
Probe: Horn_3117_00167055(1-18GHz)	Polarity: Horizontal
EUT: LED lamp	Power: AC 120V/60Hz
Note: Mode 1:Transmit at 2480MHz by Zigbee	

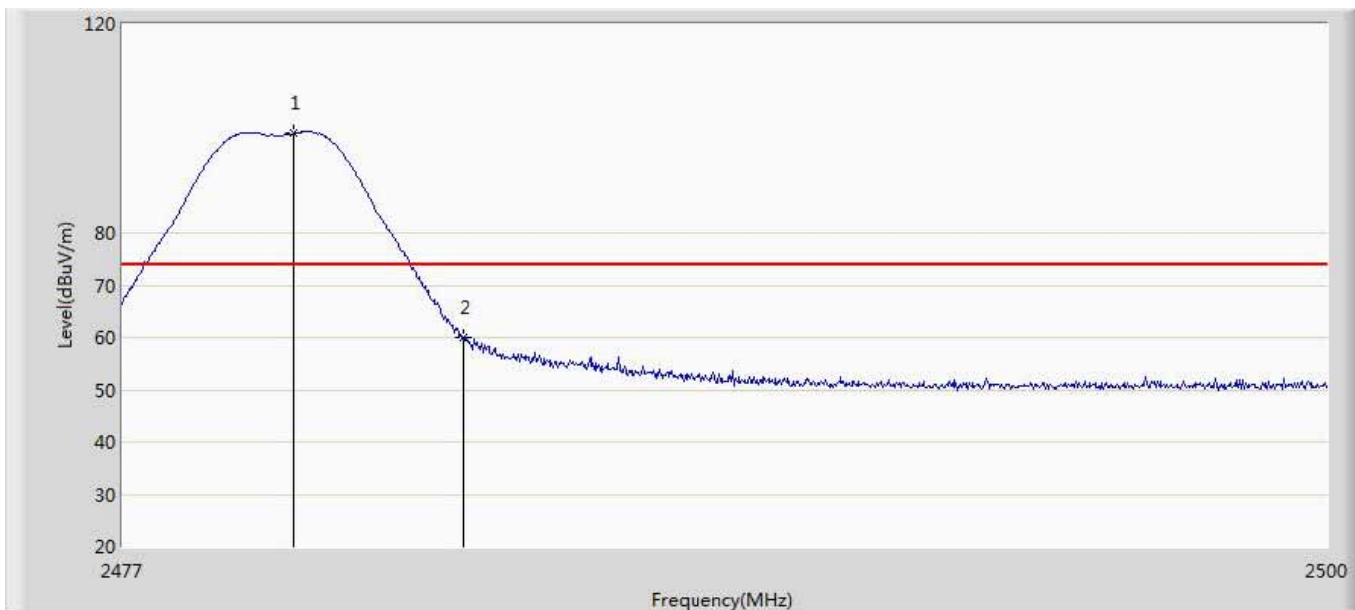

No	Mark	Frequency (MHz)	Measure Level (dBuV/m)	Reading Level (dBuV)	Over Limit (dB)	Limit (dBuV/m)	Factor (dB)	Type
1	*	2480.266	99.042	63.174	N/A	N/A	35.868	PK
2		2483.500	60.009	24.117	-13.991	74.000	35.891	PK

Engineer: Tongben	
Site: AC5	Time: 2019/08/22 - 18:40
Limit: FCC_Part15.209_RE(3m)	Margin: 0
Probe: Horn_3117_00167055(1-18GHz)	Polarity: Vertical
EUT: LED lamp	Power: AC 120V/60Hz
Note: Mode 1:Transmit at 2480MHz by Zigbee	

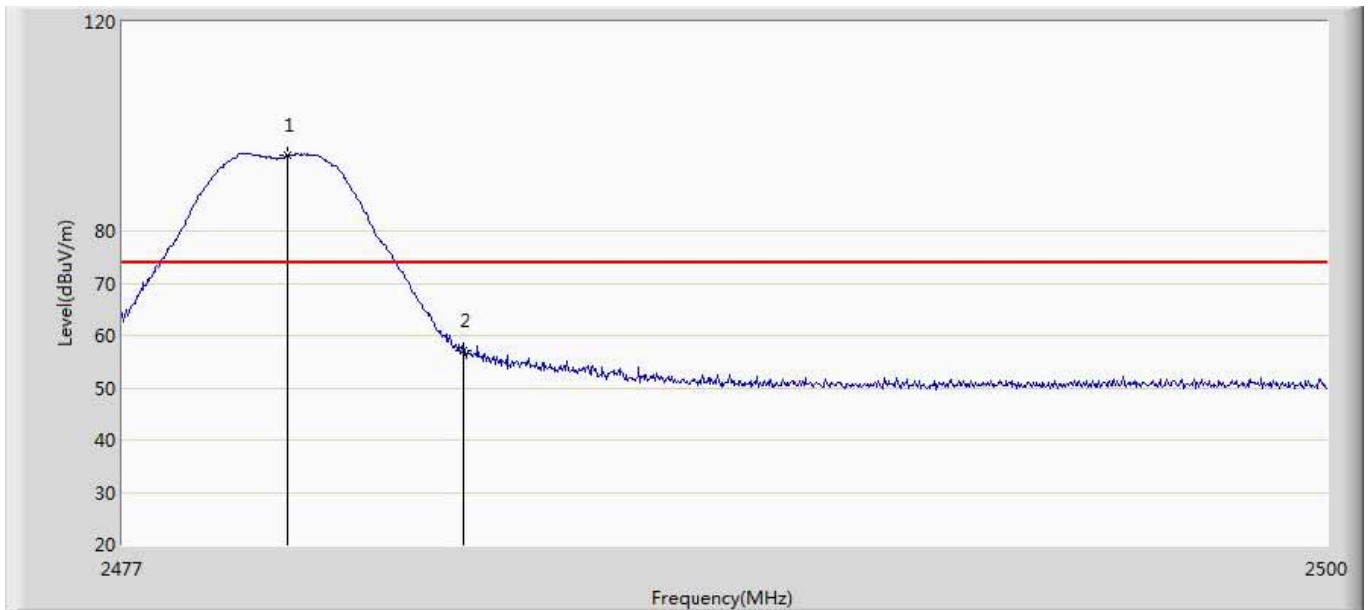

No	Mark	Frequency (MHz)	Measure Level (dBuV/m)	Reading Level (dBuV)	Over Limit (dB)	Limit (dBuV/m)	Factor (dB)	Type
1	*	2480.151	94.444	58.577	N/A	N/A	35.867	PK
2		2483.500	57.186	21.294	-16.814	74.000	35.891	PK

Engineer: Tongben	
Site: AC5	Time: 2019/08/22 - 18:42
Limit: FCC_Part15.209_RE(3m)	Margin: 0
Probe: Horn_3117_00167055(1-18GHz)	Polarity: Horizontal
EUT: LED lamp	Power: AC 120V/60Hz
Note: Mode 1:Transmit at 2480MHz by Zigbee	

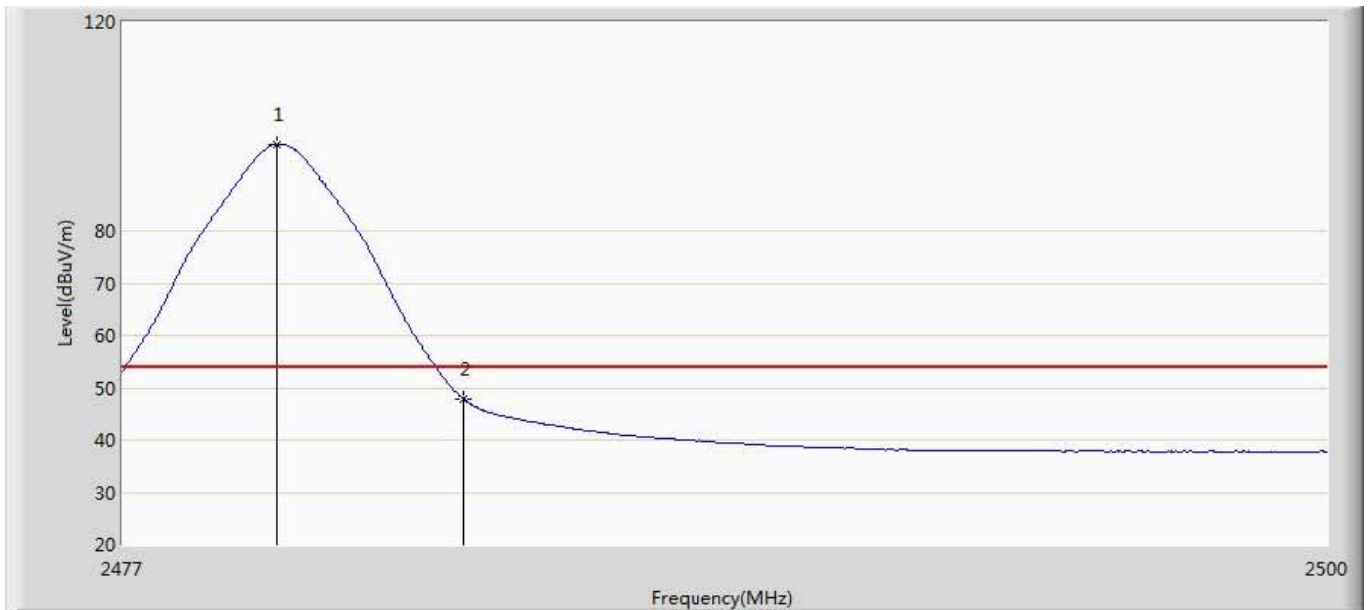

No	Mark	Frequency (MHz)	Measure Level (dBuV/m)	Reading Level (dBuV)	Over Limit (dB)	Limit (dBuV/m)	Factor (dB)	Type
1	*	2479.967	96.590	60.724	N/A	N/A	35.866	AV
2		2483.500	47.861	11.969	-6.139	54.000	35.891	AV

Engineer: Tongben	
Site: AC5	Time: 2019/08/22 - 18:44
Limit: FCC_Part15.209_RE(3m)	Margin: 0
Probe: Horn_3117_00167055(1-18GHz)	Polarity: Vertical
EUT: LED lamp	Power: AC 120V/60Hz
Note: Mode 1:Transmit at 2480MHz by Zigbee	

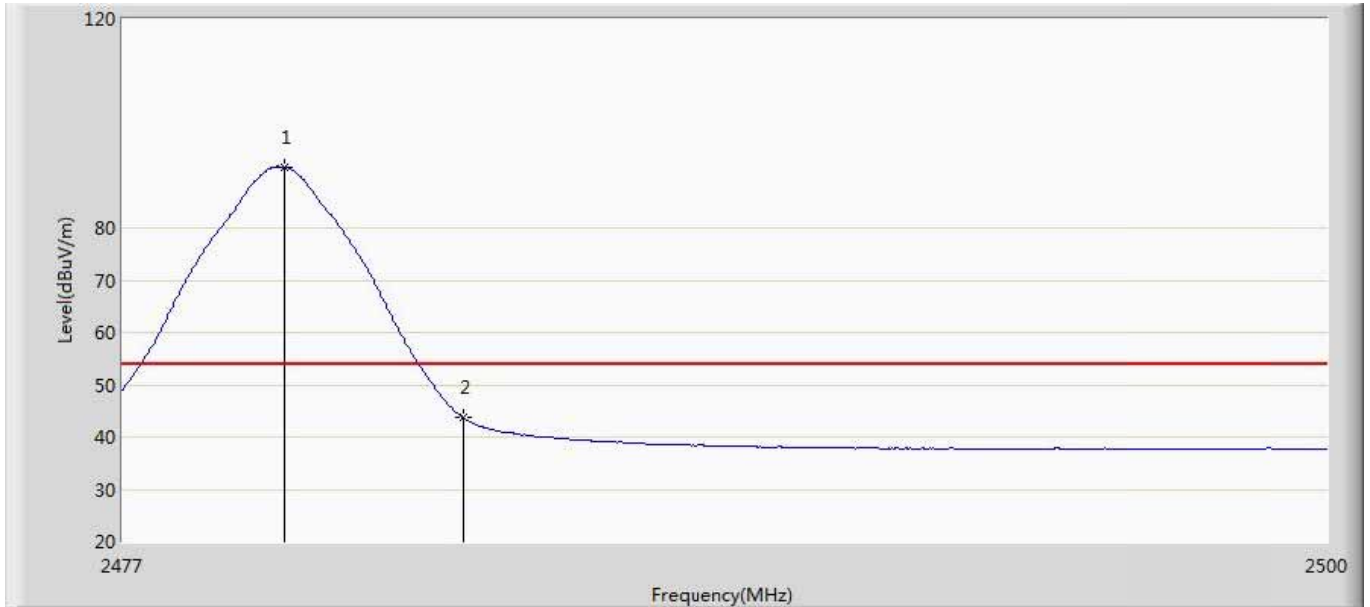

No	Mark	Frequency (MHz)	Measure Level (dBuV/m)	Reading Level (dBuV)	Over Limit (dB)	Limit (dBuV/m)	Factor (dB)	Type
1	*	2480.105	91.601	55.734	N/A	N/A	35.867	AV
2		2483.500	43.625	7.733	-10.375	54.000	35.891	AV

Diodes:

Engineer: Tongben	
Site: AC5	Time: 2019/08/12 - 10:04
Limit: FCC_Part15.209_RE(3m)	Margin: 0
Probe: Horn_3117_00167055(1-18GHz)	Polarity: Horizontal
EUT: LED lamp	Power: AC 120V/60Hz
Note: Mode 1:Transmit at 2405MHz by Zigbee	

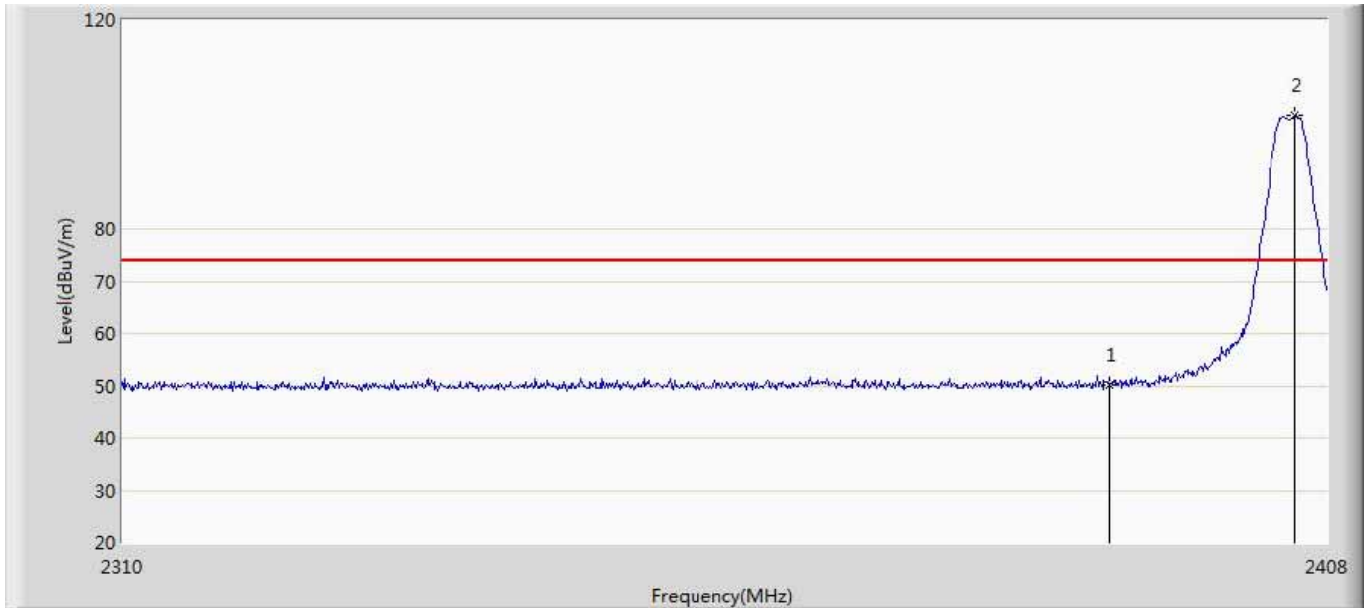

No	Mark	Frequency (MHz)	Measure Level (dBuV/m)	Reading Level (dBuV)	Over Limit (dB)	Limit (dBuV/m)	Factor (dB)	Type
1		2390.000	50.269	14.587	-23.731	74.000	35.682	PK
2	*	2405.354	101.619	65.897	N/A	N/A	35.721	PK

Engineer: Tongben	
Site: AC5	Time: 2019/08/22 - 18:59
Limit: FCC_Part15.209_RE(3m)	Margin: 0
Probe: Horn_3117_00167055(1-18GHz)	Polarity: Vertical
EUT: LED lamp	Power: AC 120V/60Hz
Note: Mode 1:Transmit at 2405MHz by Zigbee	

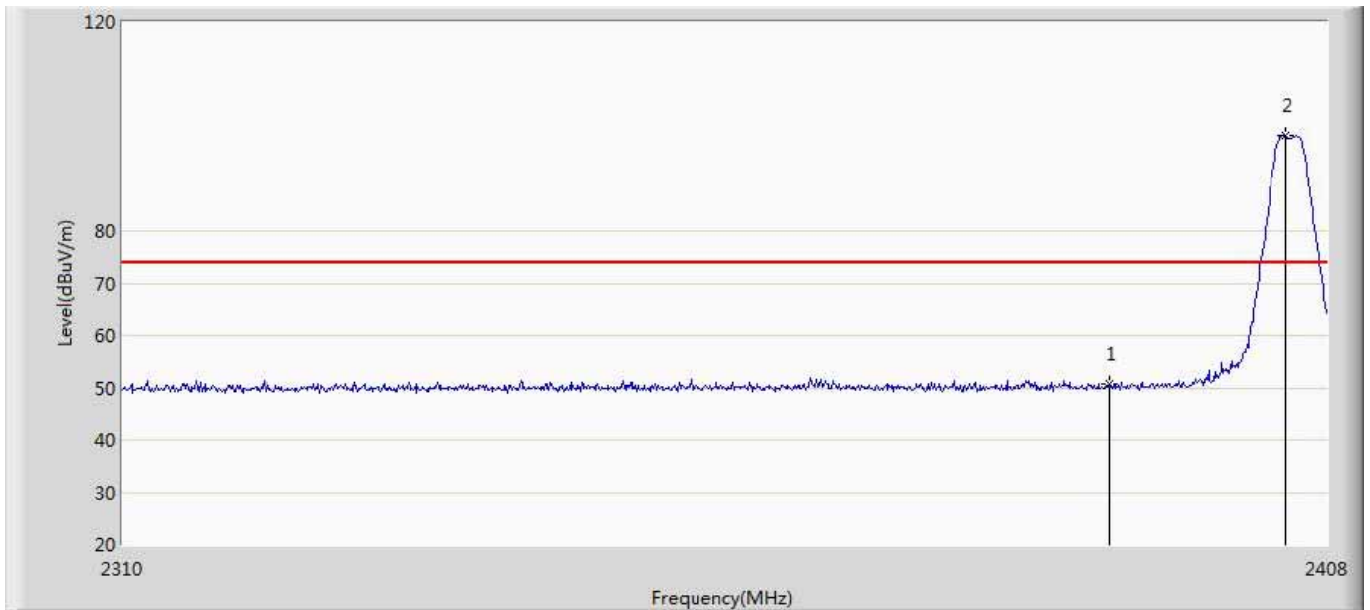

No	Mark	Frequency (MHz)	Measure Level (dBuV/m)	Reading Level (dBuV)	Over Limit (dB)	Limit (dBuV/m)	Factor (dB)	Type
1		2390.000	50.699	15.017	-23.301	74.000	35.682	PK
2	*	2404.570	98.213	62.493	N/A	N/A	35.719	PK

Engineer: Tongben	
Site: AC5	Time: 2019/08/22 - 19:01
Limit: FCC_Part15.209_RE(3m)	Margin: 0
Probe: Horn_3117_00167055(1-18GHz)	Polarity: Horizontal
EUT: LED lamp	Power: AC 120V/60Hz
Note: Mode 1:Transmit at 2405MHz by Zigbee	

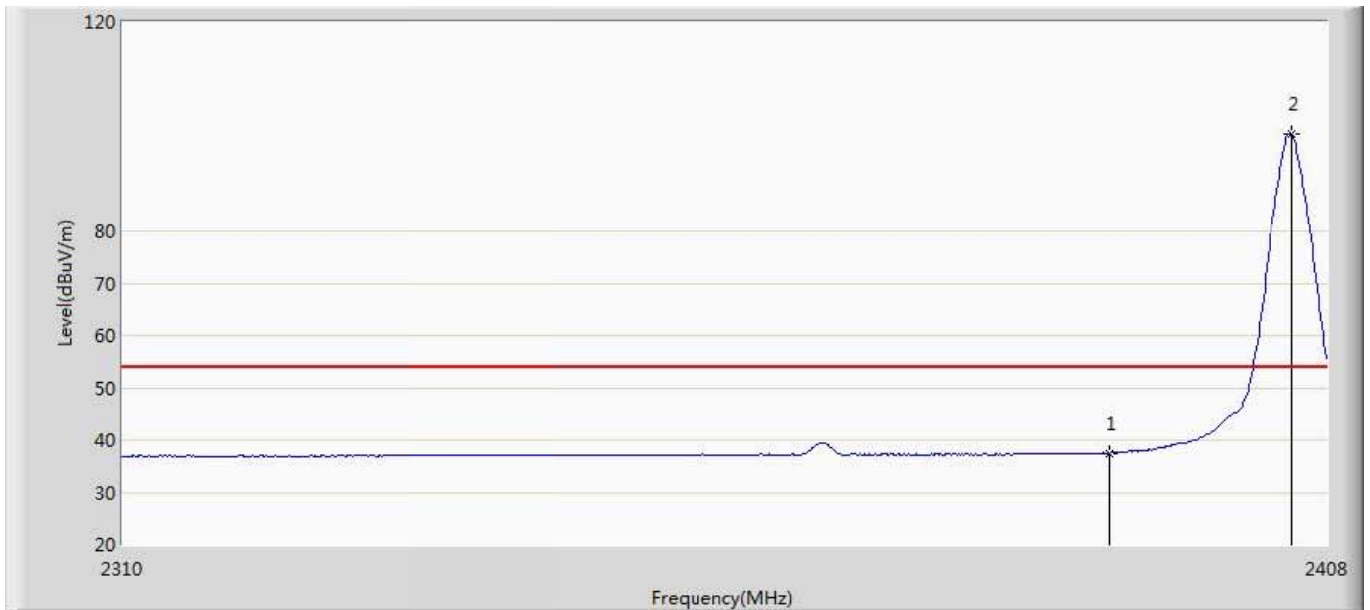

No	Mark	Frequency (MHz)	Measure Level (dBuV/m)	Reading Level (dBuV)	Over Limit (dB)	Limit (dBuV/m)	Factor (dB)	Type
1		2390.000	37.528	1.846	-16.472	54.000	35.682	AV
2	*	2405.158	98.437	62.716	N/A	N/A	35.721	AV

Engineer: Tongben	
Site: AC5	Time: 2019/08/22 - 19:02
Limit: FCC_Part15.209_RE(3m)	Margin: 0
Probe: Horn_3117_00167055(1-18GHz)	Polarity: Vertical
EUT: LED lamp	Power: AC 120V/60Hz
Note: Mode 1:Transmit at 2405MHz by Zigbee	

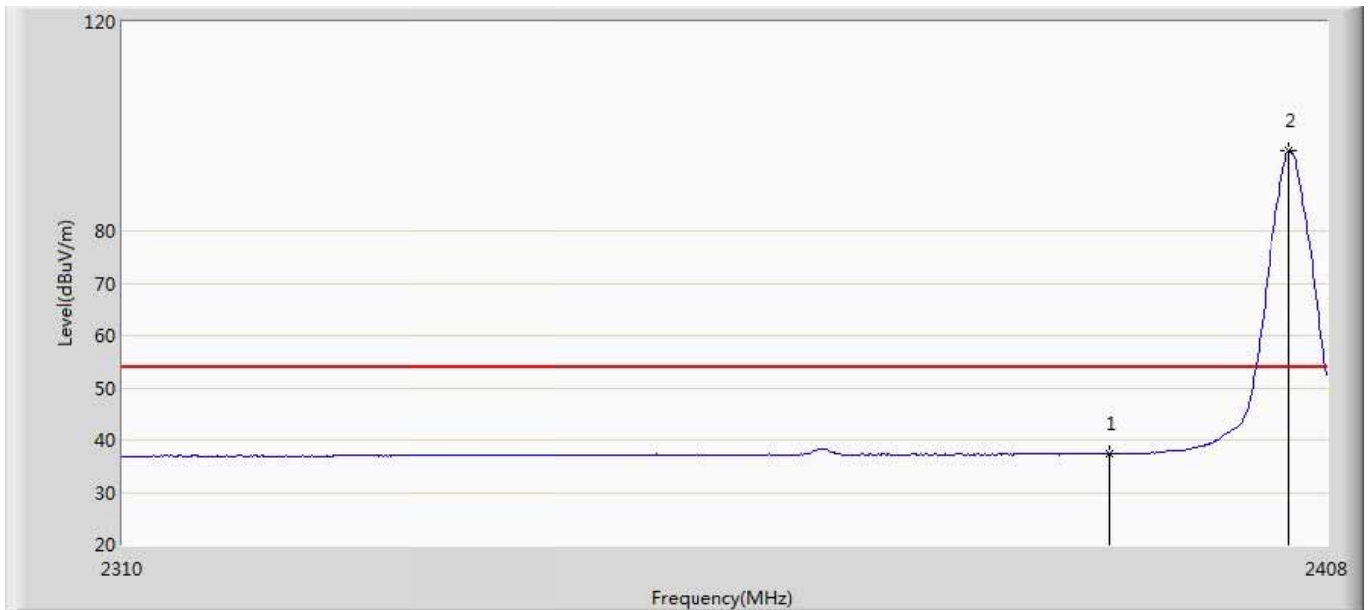

No	Mark	Frequency (MHz)	Measure Level (dBuV/m)	Reading Level (dBuV)	Over Limit (dB)	Limit (dBuV/m)	Factor (dB)	Type
1		2390.000	37.355	1.673	-16.645	54.000	35.682	AV
2	*	2404.864	95.344	59.624	N/A	N/A	35.721	AV

Engineer: Tongben	
Site: AC5	Time: 2019/08/25 - 15:12
Limit: FCC_Part15.209_RE(3m)	Margin: 0
Probe: Horn_3117_00167055(1-18GHz)	Polarity: Horizontal
EUT: LED lamp	Power: AC 120V/60Hz
Note: Mode 1:Transmit at 2480MHz by Zigbee	

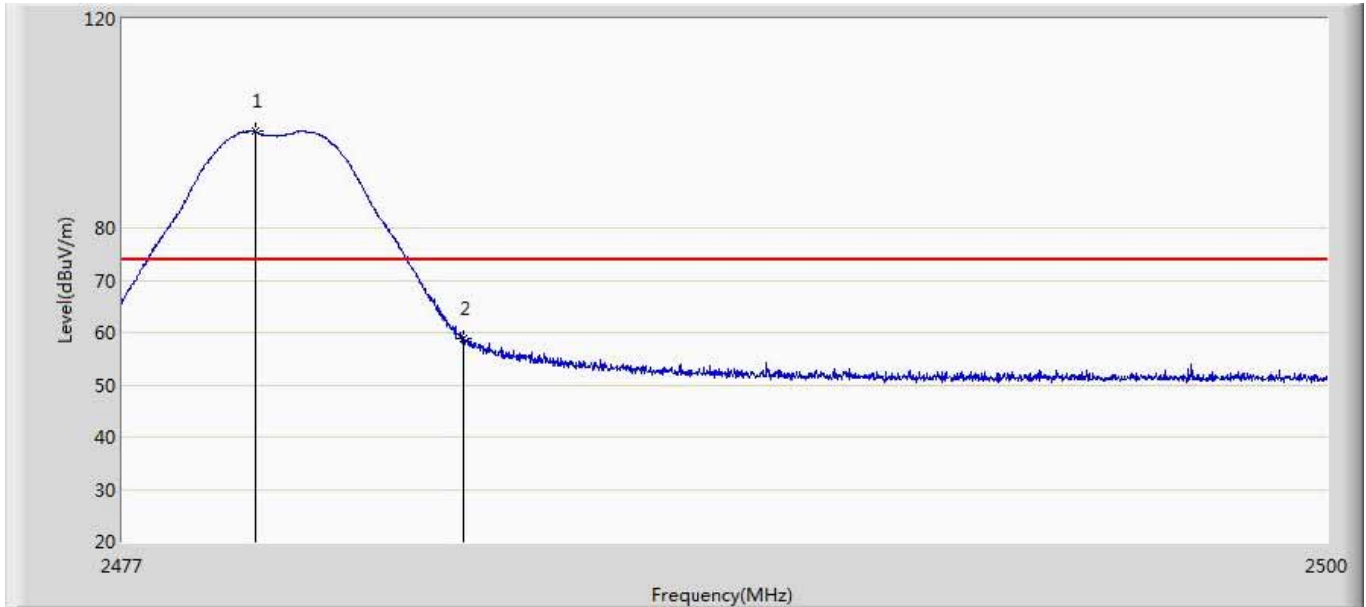

No	Mark	Frequency (MHz)	Measure Level (dBuV/m)	Reading Level (dBuV)	Over Limit (dB)	Limit (dBuV/m)	Factor (dB)	Type
1	*	2479.530	98.428	62.565	N/A	N/A	35.863	PK
2		2483.500	58.734	22.842	-15.266	74.000	35.891	PK

Engineer: Tongben	
Site: AC5	Time: 2019/08/25 - 15:20
Limit: FCC_Part15.209_RE(3m)	Margin: 0
Probe: Horn_3117_00167055(1-18GHz)	Polarity: Vertical
EUT: LED lamp	Power: AC 120V/60Hz
Note: Mode 1:Transmit at 2480MHz by Zigbee	

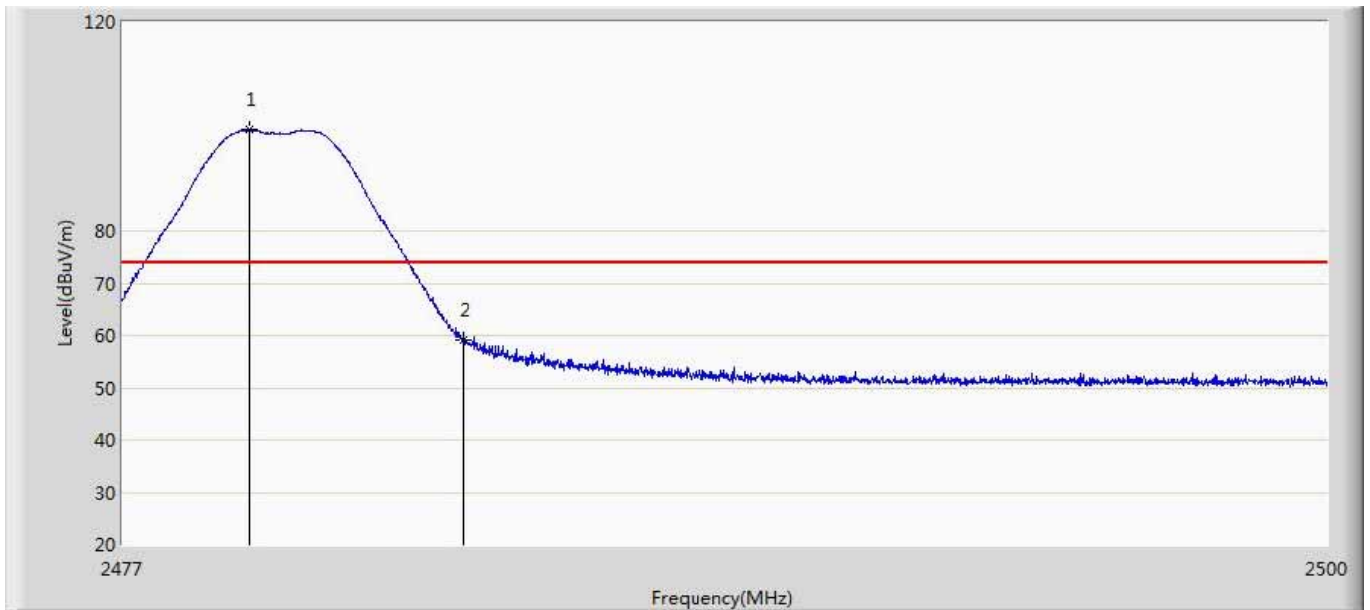

No	Mark	Frequency (MHz)	Measure Level (dBuV/m)	Reading Level (dBuV)	Over Limit (dB)	Limit (dBuV/m)	Factor (dB)	Type
1	*	2479.415	99.372	63.510	N/A	N/A	35.862	PK
2		2483.500	59.159	23.267	-14.841	74.000	35.891	PK

Engineer: Tongben	
Site: AC5	Time: 2019/08/25 - 15:21
Limit: FCC_Part15.209_RE(3m)	Margin: 0
Probe: Horn_3117_00167055(1-18GHz)	Polarity: Horizontal
EUT: LED lamp	Power: AC 120V/60Hz
Note: Mode 1:Transmit at 2480MHz by Zigbee	

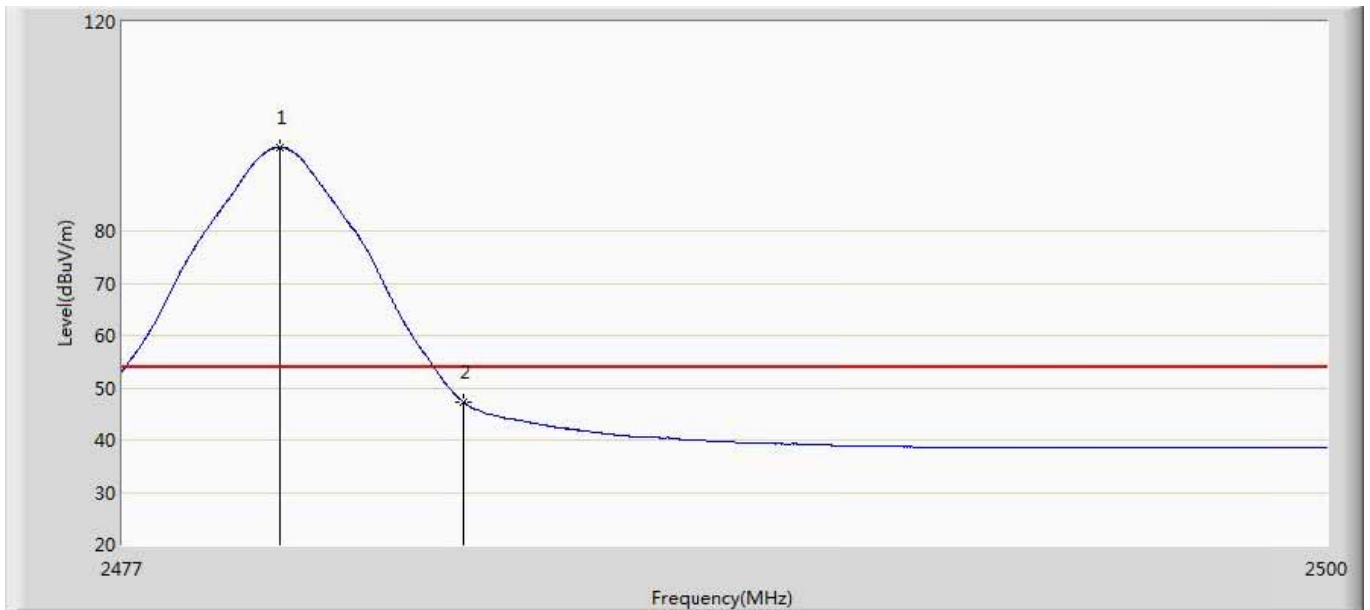

No	Mark	Frequency (MHz)	Measure Level (dBuV/m)	Reading Level (dBuV)	Over Limit (dB)	Limit (dBuV/m)	Factor (dB)	Type
1	*	2480.001	95.930	60.064	N/A	N/A	35.866	AV
2		2483.500	47.216	11.324	-6.784	54.000	35.891	AV

Engineer: Tongben	
Site: AC5	Time: 2019/08/25 - 15:23
Limit: FCC_Part15.209_RE(3m)	Margin: 0
Probe: Horn_3117_00167055(1-18GHz)	Polarity: Vertical
EUT: LED lamp	Power: AC 120V/60Hz
Note: Mode 1:Transmit at 2480MHz by Zigbee	

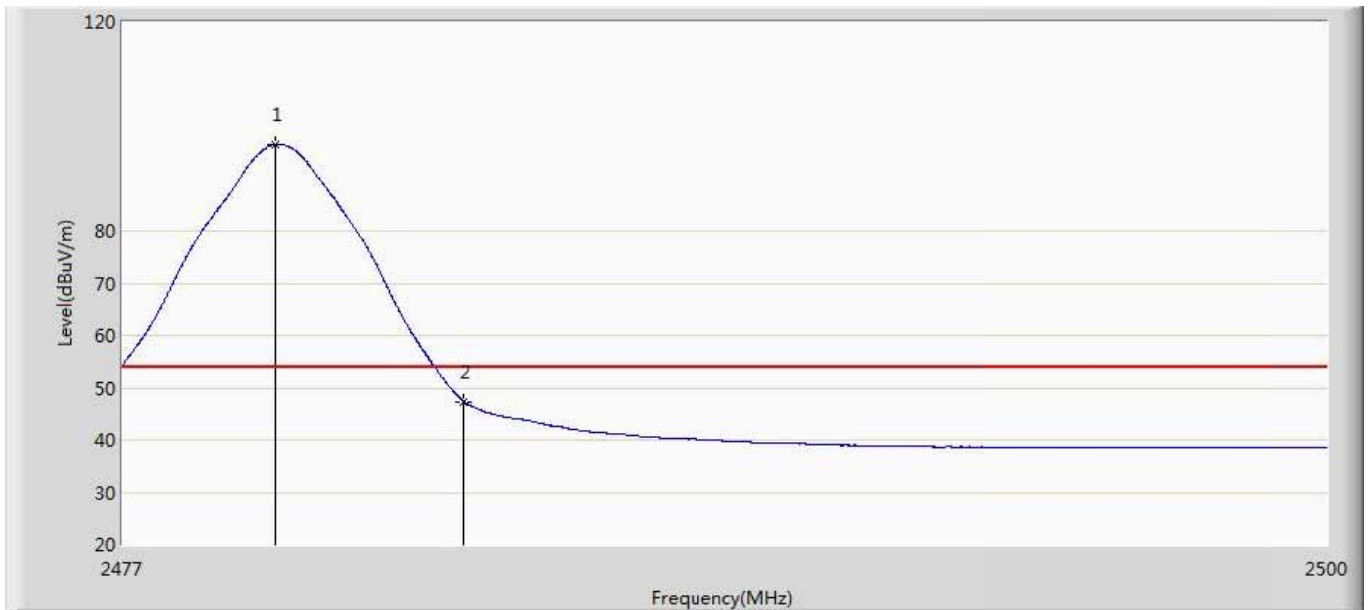

No	Mark	Frequency (MHz)	Measure Level (dBuV/m)	Reading Level (dBuV)	Over Limit (dB)	Limit (dBuV/m)	Factor (dB)	Type
1	*	2479.933	96.563	60.697	N/A	N/A	35.866	AV
2		2483.500	47.385	11.493	-6.615	54.000	35.891	AV

7. Occupied Bandwidth

7.1. Test Equipment

Occupied Bandwidth / TR-8					
Instrument	Manufacturer	Type No.	Serial No.	Cal. Date	Cal. Due Date
Spectrum Analyzer	Agilent	N9010A	MY48030494	2019.02.04	2020.02.03
EXA Spectrum Analyzer	Keysight	N9010A	MY55370495	2019.04.09	2020.04.08
MXA Signal Analyzer	Keysight	N9020A	MY56060147	2019.04.09	2020.04.08
Temperature/Humidity Meter	zhichen	ZC1-2	TR8-TH	2019.04.10	2020.04.09

Note: All equipments are calibrated with traceable calibrations. Each calibration is traceable to the national or international standards.

7.2. Test Setup

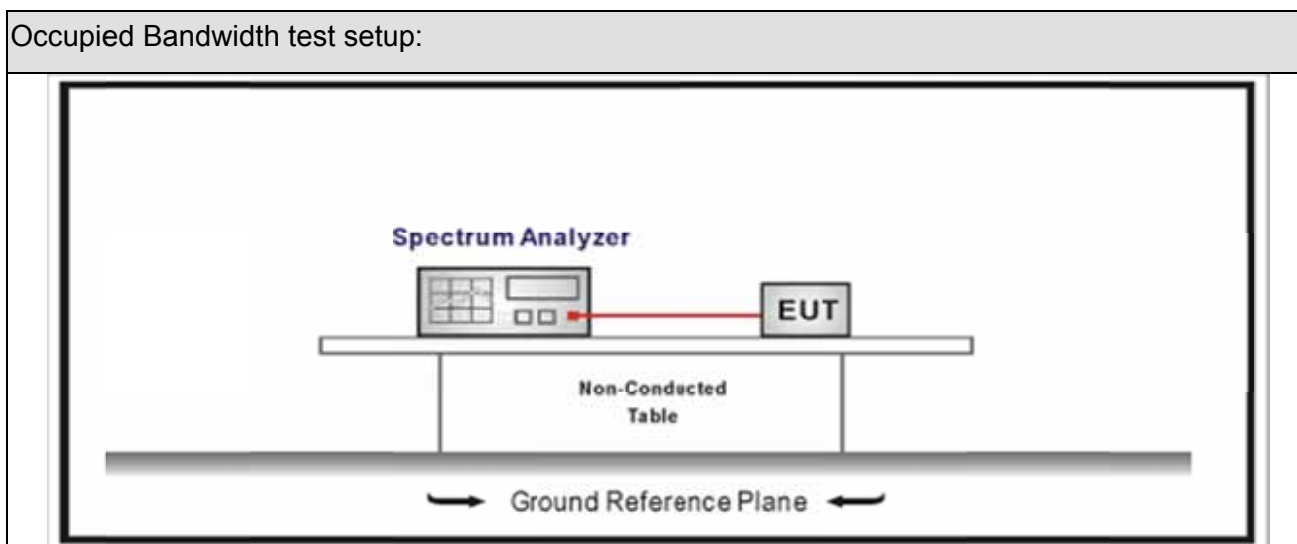



7.3. Limit

Occupied Bandwidth
Systems using digital modulation techniques operate in the 2400-2483.5 MHz. The minimum 6 dB bandwidth shall be at least 500 kHz

7.4. Test Procedure

Test Method			
	Reference Rule	Chapter	Description
<input checked="" type="checkbox"/>	ANSI C63.10	11.8	DTS bandwidth
	<input type="checkbox"/> ANSI C63.10	11.8.1	Option 1
	<input checked="" type="checkbox"/> ANSI C63.10	11.8.2	Option 2

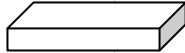
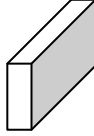
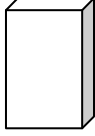
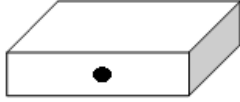
7.5. EUT test definition

Item	Occupied Bandwidth			
Device Category	<input type="checkbox"/>	Fixed point-to-point		
	<input type="checkbox"/>	Emit multiple directional beams, simultaneously or sequentially		
	<input checked="" type="checkbox"/>	Other cases		
Test mode	Mode 1			
Test method	<input type="checkbox"/>	Radiated		
		X Axis	Y Axis	Z Axis
				
		Worst Axis <input type="checkbox"/>	Worst Axis <input type="checkbox"/>	Worst Axis <input type="checkbox"/>
	<input checked="" type="checkbox"/>	Conducted		
	<input checked="" type="checkbox"/>	Chain 0		
				
	<input type="checkbox"/>	Chain 0	Chain 1	
				
	<input type="checkbox"/>	Chain 0	Chain 1	Chain 2
				

7.6. Test Result

Product Name	: LED lamp	Power	: AC 120V/60Hz
Test Mode	: Mode 1: Transmit	Test Site	: TR-8
Test Date	: 2019.08.10		

Mode	CH.	Test Freq. (MHz)	99% Occupied Bandwidth (kHz)	6dB Occupied Bandwidth (kHz)	Limit (kHz)	Result
1	11	2405	2305	1775	>500	Pass
1	18	2440	2308.7	1717	>500	Pass
1	26	2480	2317.5	1544	>500	Pass

Note : The worst case of Occupied Bandwidth as below:

Mode 1 CH11 (2405MHz)





Mode 1 CH18 (2440MHz)

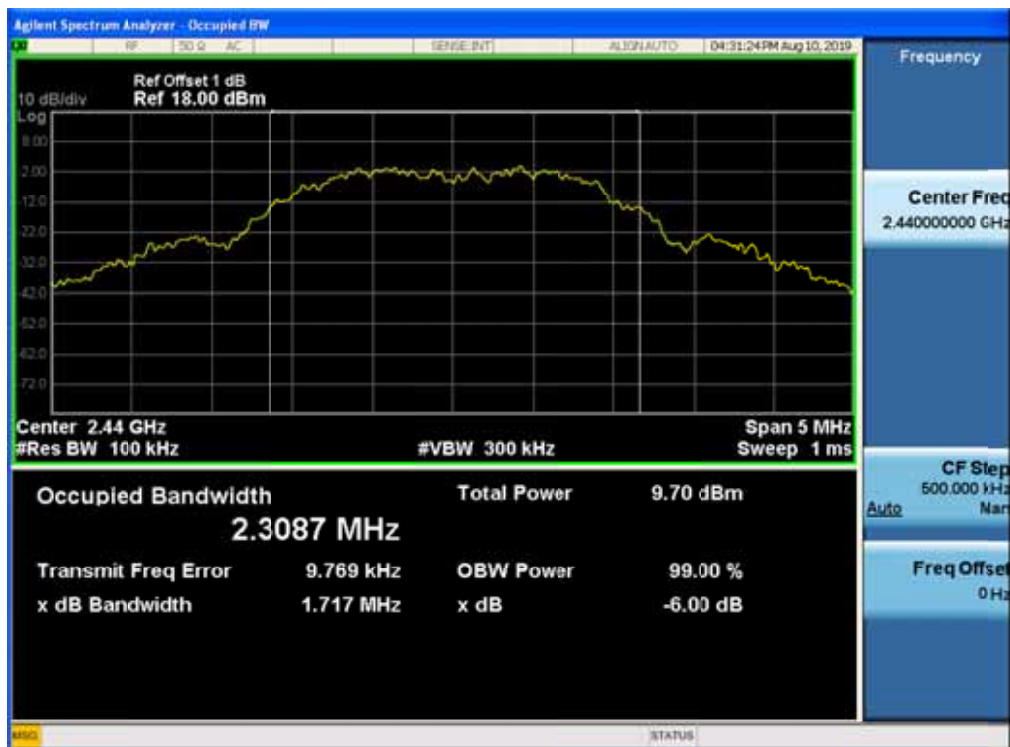



Mode 1 CH39 (2480MHz)

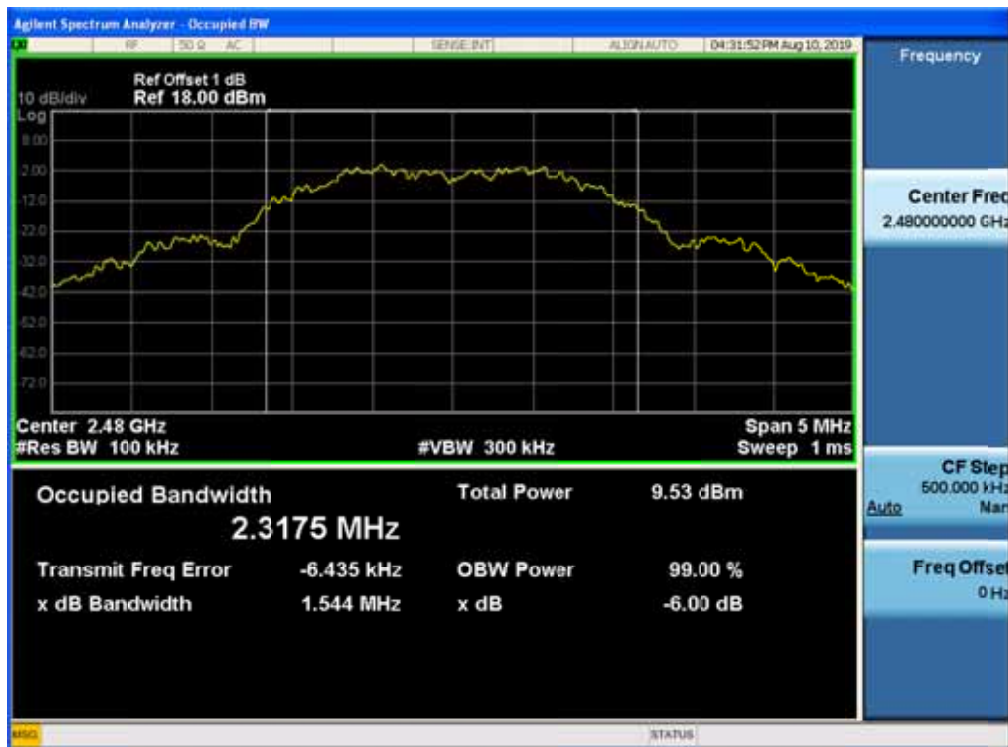



8. Fundamental emission output power

8.1. Test Equipment

Fundamental emission output power/ TR-8					
Instrument	Manufacturer	Type No.	Serial No.	Cal. Date	Cal. Due Date
Spectrum Analyzer	Agilent	E4446A	MY45300103	2019.01.04	2020.01.03
Spectrum Analyzer	Agilent	N9010A	MY48030494	2019.02.04	2020.01.15
Wideband Peak Power Meter	Anritsu	ML2495A	0905006	2018.10.14	2019.10.13
Power Sensor	Anritsu	MA2411B	0846014	2018.10.14	2019.10.13
Temperature/Humidity Meter	zhicheng	ZC1-2	TR8-TH	2019.04.10	2020.04.09

Note: All equipments are calibrated with traceable calibrations. Each calibration is traceable to the national or international standards.

8.2. Test Setup

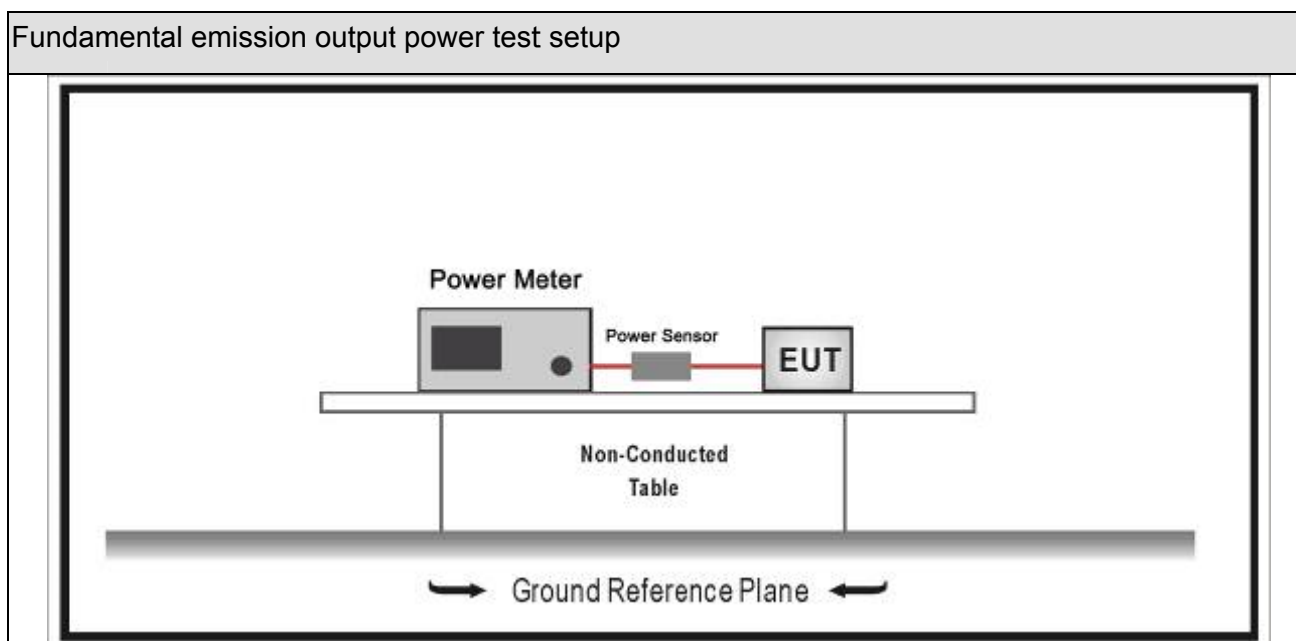



8.3. Limit

Fundamental emission output power Limit		
<input checked="" type="checkbox"/>	$G_{TX} < 6\text{dBi}$	$P_{out} \ 30\text{dBm}$
<input type="checkbox"/>	$G_{TX} > 6\text{dBi}$	
<input type="checkbox"/>	Non-Fix point-point	$P_{out} \ 30-(G_{TX}-6)$
<input type="checkbox"/>	Fix point-point	$P_{out} \ 30-[(G_{TX}-6)]/3$
<input type="checkbox"/>	Point-to-multipoint	$P_{out} \ 30-(G_{TX}-6)$
<input type="checkbox"/>	Overlap Beams	$P_{out} \ 30-[(G_{TX}-6)]/3$
<input type="checkbox"/>	Aggregate power transmitted simultaneously on all beams	$P_{out} \ 30-[(G_{TX}-6)]/3$
<input type="checkbox"/>	single directional beam	$P_{out} \ 30-[(G_{TX}-6)]/3+8\text{dB}$
<p>Note 1 : G_{TX} directional gain of transmitting antennas.</p> <p>Note 2 : P_{out} is maximum peak conducted output power .</p>		

8.4. Test Procedure

Fundamental emission output power Test Method					
	References Rule		Chapter	Description	
<input checked="" type="checkbox"/>	ANSI C63.10		11.9	Fundamental emission output power	
	<input checked="" type="checkbox"/>	ANSI C63.10		11.9.1	Maximum peak conducted output power
	<input type="checkbox"/>	ANSI C63.10	11.9.1.1	RBW ≥ DTS bandwidth	
	<input type="checkbox"/>	ANSI C63.10	11.9.1.2	Integrated band power method	
	<input checked="" type="checkbox"/>	ANSI C63.10	11.9.1.3	PKPM1 Peak power meter method	
	<input checked="" type="checkbox"/>	ANSI C63.10		11.9.2	Maximum conducted (average) output power
	<input type="checkbox"/>	ANSI C63.10		11.9.2.2	Measurement using a spectrum analyzer (SA)
	<input type="checkbox"/>	ANSI C63.10	11.9.2.2.2	Method AVGSA-1(Duty cycle 98%)	
	<input type="checkbox"/>	ANSI C63.10	11.9.2.2.3	Method AVGSA-1A(Duty cycle 98%)	
	<input type="checkbox"/>	ANSI C63.10	11.9.2.2.4	Method AVGSA-2(Duty cycle 98%)	
	<input type="checkbox"/>	ANSI C63.10	11.9.2.2.5	Method AVGSA-2A(Duty cycle 98%)	
	<input type="checkbox"/>	ANSI C63.10	11.9.2.2.4	Method AVGSA-3	
	<input type="checkbox"/>	ANSI C63.10	11.9.2.2.5	Method AVGSA-3A	
	<input checked="" type="checkbox"/>	ANSI C63.10		11.9.2.3	Measurement using a power meter (PM)
	<input checked="" type="checkbox"/>	ANSI C63.10	11.9.2.3.1	Method AVGPM	
	<input type="checkbox"/>	ANSI C63.10	11.9.2.3.2	Method AVGPM-G	

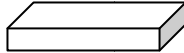
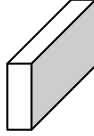
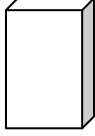
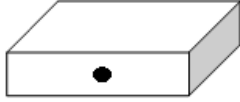
8.5. EUT test definition

Item	Fundamental emission output power			
Device Category	<input type="checkbox"/>	Fixed point-to-point		
	<input type="checkbox"/>	Emit multiple directional beams, simultaneously or sequentially		
	<input checked="" type="checkbox"/>	Other cases		
Test mode	Mode 1			
Test method	<input type="checkbox"/>	Radiated		
		X Axis	Y Axis	Z Axis
				
		Worst Axis <input type="checkbox"/>	Worst Axis <input type="checkbox"/>	Worst Axis <input type="checkbox"/>
	<input checked="" type="checkbox"/>	Conducted		
	<input checked="" type="checkbox"/>	Chain 0		
				
	<input type="checkbox"/>	Chain 0	Chain 1	
				
	<input type="checkbox"/>	Chain 0	Chain 1	Chain 2
				

8.6. Test Result

Product Name	: LED lamp	Power	: AC 120V/60Hz
Test Mode	: Mode 1	Test Site	: TR-8
Test Date	: 2019.08.16		

Muruta:

Mode	Channel	Test Frequency (MHz)	Measurement Power Output (dBm)	Limit (dBm)	Result
1	11	2405	7.56	30	Pass
1	18	2440	7.83	30	Pass
1	26	2480	7.63	30	Pass

Diodes:

Mode	Channel	Test Frequency (MHz)	Measurement Power Output (dBm)	Limit (dBm)	Result
1	11	2405	7.88	30	Pass
1	18	2440	8.03	30	Pass
1	26	2480	7.95	30	Pass

9. Power Spectral Density

9.1. Test Equipment

Power Spectral Density / TR-8					
Instrument	Manufacturer	Type No.	Serial No.	Cal. Date	Cal. Due Date
Spectrum Analyzer	Agilent	N9010A	MY48030494	2019.02.04	2020.02.03
EXA Spectrum Analyzer	Keysight	N9010A	MY55370495	2019.04.09	2020.04.08
MXA Signal Analyzer	Keysight	N9020A	MY56060147	2019.04.09	2020.04.08
Temperature/Humidity Meter	zhichen	ZC1-2	TR8-TH	2019.04.10	2020.04.09

Note: All equipments are calibrated with traceable calibrations. Each calibration is traceable to the national or international standards.

9.2. Test Setup

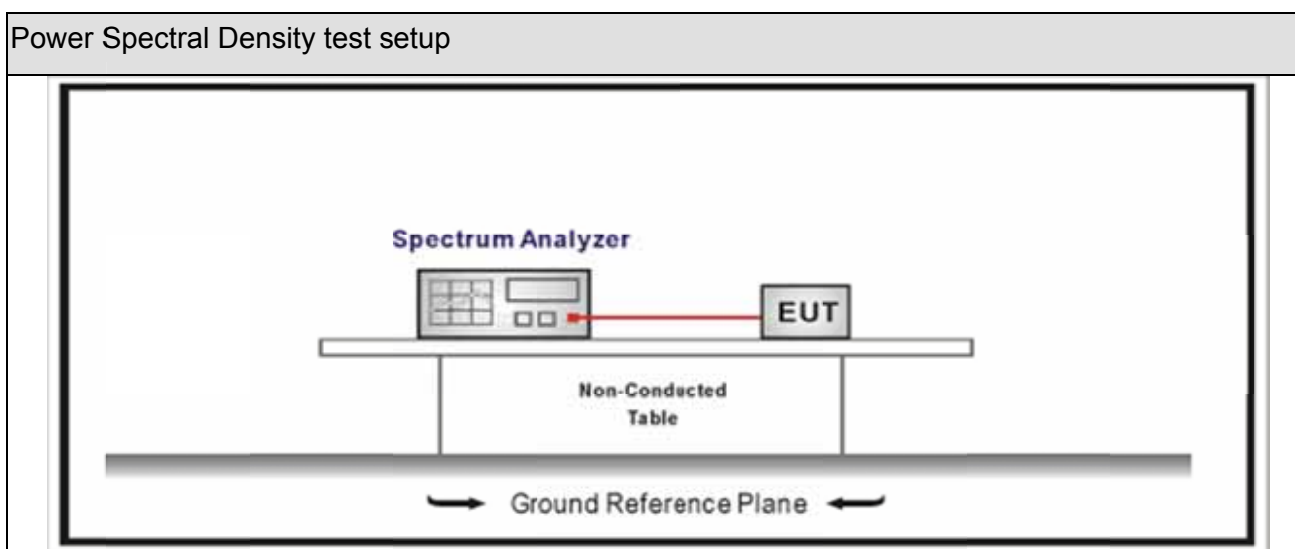



9.3. Limit

Power Spectral Density Limit
Power Spectral Density 8dBm/3kHz

9.4. Test Procedure

Power Spectral Density Test Method			
	References Rule	Chapter	Description
<input checked="" type="checkbox"/>	ANSI C63.10	11.10	Maximum power spectral density level in the fundamental emission
<input checked="" type="checkbox"/>	ANSI C63.10	11.10.2	Method PKPSD (peak PSD)
<input type="checkbox"/>	ANSI C63.10	11.10.3	Method AVGPSD-1(Duty cycle 98%)
<input type="checkbox"/>	ANSI C63.10	11.10.4	Method AVGPSD-1A(Duty cycle 98%)
<input type="checkbox"/>	ANSI C63.10	11.10.5	Method AVGPSD-2(Duty cycle < 98%)
<input type="checkbox"/>	ANSI C63.10	11.10.6	Method AVGPSD-2A(Duty cycle < 98%)
<input type="checkbox"/>	ANSI C63.10	11.10.7	Method AVGPSD-3
<input type="checkbox"/>	ANSI C63.10	11.10.8	Method AVGPSD-3A

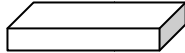
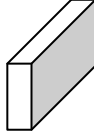
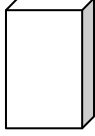
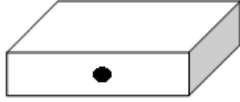
9.5. EUT test definition

Item	Power Spectral Density Test Method			
Device Category	<input type="checkbox"/>	Fixed point-to-point		
	<input type="checkbox"/>	Emit multiple directional beams, simultaneously or sequentially		
	<input checked="" type="checkbox"/>	Other cases		
Test mode	Mode 1			
Test method	<input type="checkbox"/>	Radiated		
		X Axis	Y Axis	Z Axis
				
		Worst Axis <input type="checkbox"/>	Worst Axis <input type="checkbox"/>	Worst Axis <input type="checkbox"/>
	<input checked="" type="checkbox"/>	Conducted		
	<input checked="" type="checkbox"/>	Chain 0		
				
	<input type="checkbox"/>	Chain 0	Chain 1	
				
	<input type="checkbox"/>	Chain 0	Chain 1	Chain 2
				

9.6. Test Result

Product Name	: LED lamp	Power	: AC 120V/60Hz
Test Mode	: Mode 1: Transmit	Test Site	: TR-8
Test Date	: 2019.09.12		

Mode	Channel	Test Frequency (MHz)	Measurement PSD (dBm/3kHz)	Total PSD (dBm/3kHz)	Limit (dBm/3kHz)	Result
1	11	2405	-6.319	-6.319	8	Pass
1	18	2440	-6.352	-6.352	8	Pass
1	26	2480	-8.231	-8.231	8	Pass

Note : The worst case of Power Spectral Density as below:

Mode 1 CH11(2405MHz)



Mode 1 CH18(2440MHz)



Mode 1 CH26(2480MHz)



10. Antenna Requirement

10.1. Limit

Antenna Requirement Limit	
<p>An intentional radiator shall be designed to ensure that no antenna other than that furnished by the responsible party shall be used with the device. The use of a permanently attached antenna or of an antenna that uses a unique coupling to the intentional radiator shall be considered sufficient to comply with the provisions of this section. The manufacturer may design the unit so that a broken antenna can be replaced by the user, but the use of a standard antenna jack or electrical connector is prohibited. This requirement does not apply to carrier current devices or to devices operated under the provisions of §15.211, §15.213, §15.217, §15.219, or §15.221. Further, this requirement does not apply to intentional radiators that must be professionally installed, such as perimeter protection systems and some field disturbance sensors, or to other intentional radiators which, in accordance with §15.31(d), must be measured at the installation site. However, the installer shall be responsible for ensuring that the proper antenna is employed so that the limits in this part are not exceeded.</p>	

10.2. Antenna Connector Construction

Antenna Connector Construction	
<input checked="" type="checkbox"/>	The use of a permanently attached antenna
<input type="checkbox"/>	The antenna use of a unique coupling to the intentional radiator
<input type="checkbox"/>	The use of a nonstandard antenna jack or electrical connector
Please refer to the attached document "Internal Photograph" to show the antenna connector.	

_____ The End _____