



# Test Report

## FCC Part15 Subpart C & RSS-247 Issue 2

Product Name : LED lamp  
Model No. : 9290022268  
FCC ID : 2AGBW9290022268X  
IC : 20812-2268X

Applicant : Signify (China) Investment Co., Ltd.

Address : Building no.9, Lane 888, Tianlin Road, Minhang District,  
Shanghai 200233, China

Date of Receipt : Jul. 30, 2019  
Test Date : Jul. 31, 2019 ~ Aug. 30, 2019  
Issued Date : Sep. 01, 2019  
Report No. : 1972175R-RF-US-P06V01  
Report Version : V1.0

The test results presented in this report relate only to the object tested.

This report shall not be reproduced, except in full, without the written approval of the Issuing CB Testing Laboratory.

The measurement result is considered in conformance with the requirement if it is within the prescribed limit, It is not necessary to calculate the uncertainty associated with the measurement result.

This report is not used for social proof in China (or Mainland China) market.

# Test Report Certification

Issued Date : Sep. 01, 2019  
Report No. : 1972175R-RF-US-P06V01



Product Name : LED lamp  
 Applicant : Signify (China) Investment Co., Ltd.  
 Address : Building no.9, Lane 888, Tianlin Road, Minhang District, Shanghai 200233, China  
 Manufacturer : Signify (China) Investment Co., Ltd.  
 Address : Building no.9, Lane 888, Tianlin Road, Minhang District, Shanghai 200233, China  
 Model No. : 9290022268  
 FCC ID : 2AGBW9290022268X  
 IC : 20812-2268X  
 EUT Voltage : 110-130 Vac, 50-60 Hz, 9.5W  
 Test Voltage : AC 120V/60Hz  
 Brand Name : PHILIPS  
 Applicable Standard : FCC CFR Title 47 Part 15 Subpart C: 2017  
 KDB 558074 D01v05r02  
 RSS 247: Issue2; RSS GEN: Issue5  
 ANSI C63.4:2014; ANSI C63.10:2013;  
 Test Result : Complied  
 Performed Location : DEKRA Testing and Certification (Suzhou) Co., Ltd.  
 No.99 Hongye Rd., Suzhou Industrial Park, Suzhou, 215006, Jiangsu, China  
 TEL: +86-512-6251-5088 / FAX: +86-512-6251-5098  
 FCC Designation Number: CN1199;  
 ISED CAB identifier: CN0040

Documented By : Kathy Feng  
 (Project Assistant: Kathy Feng)

Reviewed By : Frank he  
 (Senior Engineer: Frank He )

Approved By : Jack zhang  
 (Engineer Supervisor: Jack Zhang )

## TABLE OF CONTENTS

| Description  | Page |
|--|------|
| 1. General Information.....                          | 6    |
| 1.1. EUT Description .....                           | 6    |
| 1.2. Working Frequency of Each Channel: .....        | 7    |
| 1.3. Antenna information .....                       | 7    |
| 1.4. Mode of Operation.....                          | 8    |
| 1.5. Tested System Details .....                     | 8    |
| 1.6. Configuration of Tested System.....             | 9    |
| 1.7. EUT Exercise Software.....                      | 10   |
| 2. Technical Test.....                               | 11   |
| 2.1. Summary of Test Result.....                     | 11   |
| 2.2. Test Environment.....                           | 13   |
| 2.3. Measurement Uncertainty .....                   | 13   |
| 3. AC Power Line Conducted Emission .....            | 14   |
| 3.1. Test Equipment.....                             | 14   |
| 3.2. Test Setup.....                                 | 14   |
| 3.3. Limit.....                                      | 15   |
| 3.4. Test Procedure .....                            | 15   |
| 3.5. Test Result.....                                | 16   |
| 4. Emissions in restricted frequency bands .....     | 20   |
| 4.1. Test Equipment.....                             | 20   |
| 4.2. Test Setup.....                                 | 21   |
| 4.3. Limit.....                                      | 22   |
| 4.4. Test Procedure .....                            | 22   |
| 4.5. EUT test Axis definition.....                   | 26   |
| 4.6. Test Result.....                                | 27   |
| 5. Emissions in non-restricted frequency bands ..... | 44   |
| 5.1. Test Equipment.....                             | 44   |
| 5.2. Test Setup.....                                 | 44   |
| 5.3. Limit.....                                      | 45   |
| 5.4. Test Procedure .....                            | 46   |
| 5.5. EUT test Axis definition.....                   | 47   |
| 5.6. Test Result.....                                | 48   |
| 6. Radiated Emission Band Edge .....                 | 49   |
| 6.1. Test Equipment.....                             | 49   |
| 6.2. Test Setup.....                                 | 50   |
| 6.3. Limit.....                                      | 50   |
| 6.4. Test Procedure .....                            | 51   |

- 6.5. EUT test definition ..... 52
- 6.6. Duty Cycle ..... 53
- 6.7. Test Result ..... 54
- 7. Occupied Bandwidth ..... 70
- 7.1. Test Equipment..... 70
- 7.2. Test Setup..... 70
- 7.3. Limit..... 71
- 7.4. Test Procedure ..... 71
- 7.5. EUT test definition ..... 72
- 7.6. Test Result..... 73
- 8. Fundamental emission output power ..... 75
- 8.1. Test Equipment..... 75
- 8.2. Test Setup..... 75
- 8.3. Limit..... 76
- 8.4. Test Procedure ..... 77
- 8.5. EUT test definition ..... 78
- 8.6. Test Result..... 79
- 9. Power Spectral Density ..... 80
- 9.1. Test Equipment..... 80
- 9.2. Test Setup..... 80
- 9.3. Limit..... 80
- 9.4. Test Procedure ..... 81
- 9.5. EUT test definition ..... 82
- 9.6. Test Result..... 83
- 10. Antenna Requirement..... 84
- 10.1. Limit..... 84
- 10.2. Antenna Connector Construction..... 84

### History of This Test Report

| REPORT NO.            | VERSION | DESCRIPTION           | ISSUED DATE   |
|-----------------------|---------|-----------------------|---------------|
| 1972175R-RF-US-P06V01 | V1.0    | Initial Issued Report | Sep. 01, 2019 |
|                       |         |                       |               |
|                       |         |                       |               |
|                       |         |                       |               |

## 1. General Information

### 1.1. EUT Description

|                    |                             |
|--------------------|-----------------------------|
| Product Name       | LED lamp                    |
| Model No.          | 9290022268                  |
| EUT Voltage        | 110-130 Vac, 50-60 Hz, 9.5W |
| Test Voltage       | AC 120V/60Hz                |
| <b>Zigbee</b>      |                             |
| Frequency Range    | 2405 ~ 2480MHz              |
| Channel Number     | 16                          |
| Type of Modulation | DSSS-OQPSK                  |
| Data Rate          | 250kbps                     |
| Antenna Type       | Reference to Antenna List   |

Note 1: LED lamp supports two kinds of Crystal oscillator (murata/ Diodes), there is not any change in RF design, circuitry or construction for this device, including RF parameters (antenna, software, firmware and hardware versions, power, frequency ranges, etc.), so only power, spurious emission and band-edge were tested for different crystal oscillator, the test data of worse mode is showed with other test items.

### 1.2. Working Frequency of Each Channel:

| Zigbee Working Frequency of Each Channel: |           |         |           |         |           |         |           |
|---|-----------|---------|-----------|---------|-----------|---------|-----------|
| Channel                                   | Frequency | Channel | Frequency | Channel | Frequency | Channel | Frequency |
| 11  | 2405 MHz  | 12      | 2410 MHz  | 13      | 2415 MHz  | 14      | 2420 MHz  |
| 15  | 2425 MHz  | 16      | 2430 MHz  | 17      | 2435 MHz  | 18      | 2440 MHz  |
| 19  | 2445 MHz  | 20      | 2450 MHz  | 21      | 2455 MHz  | 22      | 2460 MHz  |
| 23  | 2465 MHz  | 24      | 2470 MHz  | 25      | 2475 MHz  | 26      | 2480 MHz  |

### 1.3. Antenna information

|                      |                                     |           |                                     |                            |                          |           |  |
|----------------------|-------------------------------------|-----------|-------------------------------------|----------------------------|--------------------------|-----------|--|
| Antenna manufacturer | N/A                                 |           |                                     |                            |                          |           |  |
| Antenna Delivery     | <input checked="" type="checkbox"/> | 1*TX+1*RX | <input type="checkbox"/>            | 2*TX+2*RX                  | <input type="checkbox"/> | 3*TX+3*RX |  |
| Antenna technology   | <input checked="" type="checkbox"/> | SISO      |                                     |                            |                          |           |  |
|                      | <input type="checkbox"/>            | MIMO      | <input type="checkbox"/>            | Basic                      |                          |           |  |
|                      |                                     |           | <input type="checkbox"/>            | CDD                        |                          |           |  |
|                      |                                     |           | <input type="checkbox"/>            | Beam-forming               |                          |           |  |
| Antenna Type         | <input type="checkbox"/>            | External  | <input type="checkbox"/>            | Dipole                     |                          |           |  |
|                      | <input checked="" type="checkbox"/> | Internal  | <input type="checkbox"/>            | PIFA                       |                          |           |  |
|                      |                                     |           | <input checked="" type="checkbox"/> | PCB                        |                          |           |  |
|                      |                                     |           | <input type="checkbox"/>            | Ceramic Chip Antenna       |                          |           |  |
|                      |                                     |           | <input type="checkbox"/>            | Metal plate type F antenna |                          |           |  |
| Antenna Gain         | 0dBi                                |           |                                     |                            |                          |           |  |

#### 1.4. Mode of Operation

|                  |
|------------------|
| Test Mode        |
| Mode 1: Transmit |

#### 1.5. Tested System Details

The types for all equipment, plus descriptions of all cables used in the tested system (including inserted cards) are:

| No. | Product           | Manufacturer | Model No. | Serial No. | Power Cord       |
|-----|-------------------|--------------|-----------|------------|------------------|
| 1   | Notebook          | Think Pad    | 2526      | LV-A3285   | Power by adapter |
| 2   | Zigbee Receiver   | N/A          | N/A       | N/A        | N/A              |
| A   | USB Control Cable | N/A          | N/A       | N/A        | Shield, 1m       |
| B   | USB Control Cable | N/A          | N/A       | N/A        | Shield, 10m      |



### 1.6. Configuration of Tested System

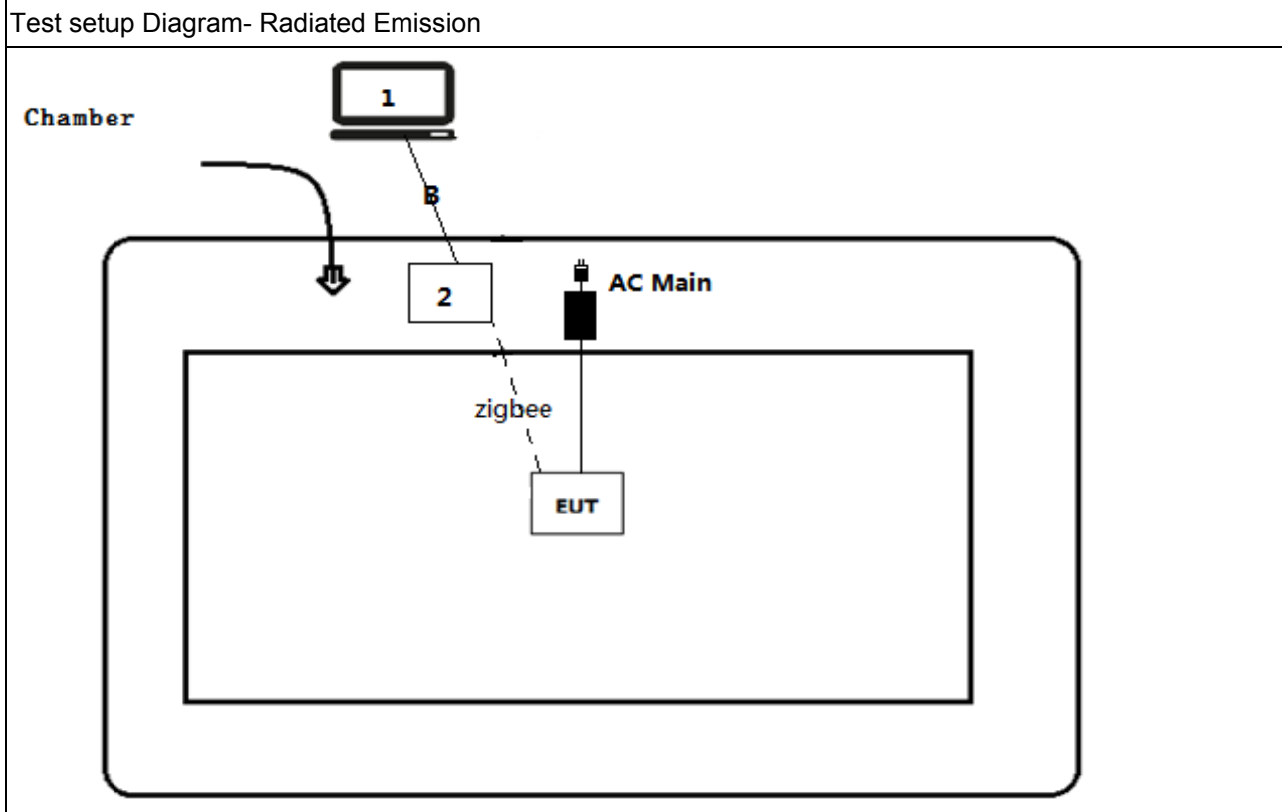
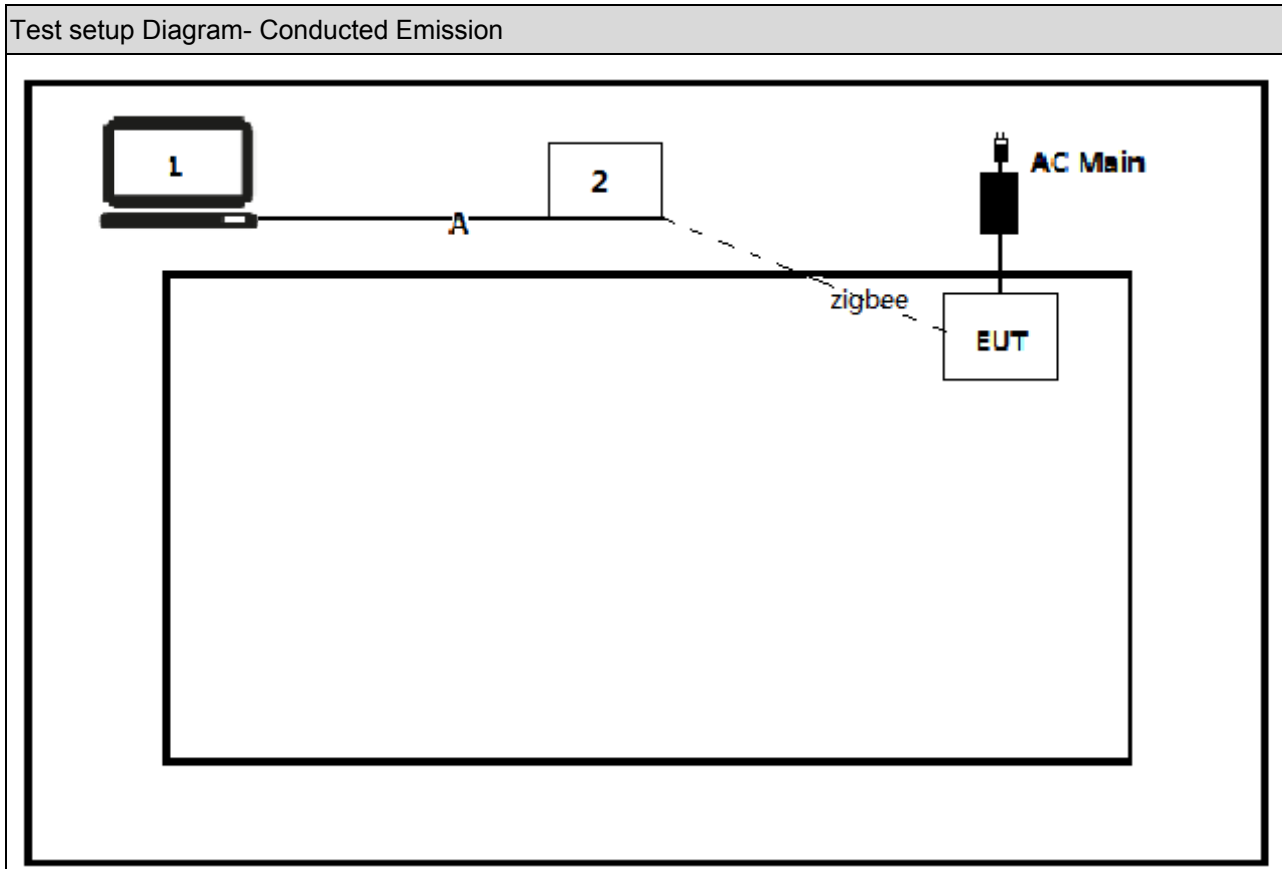

### 1.7. EUT Exercise Software

|   |   |
|---|---|
| 1 | Setup the EUT and simulators as shown on above.                 |
| 2 | Turn on the power of equipment.                                 |
| 3 | Run the test software (HueApprobaton Tool).                     |
| 4 | Select the transmission mode and test channel, then start test. |

## 2. Technical Test

### 2.1. Summary of Test Result

#### FCC:

| Performed Test Item                         | Normative References                                    | Worst case mode | Limit      | Result |
|---|---|-----------------|------------|--------|
| AC Power Line Conducted Emission            | FCC CFR Title 47 Part 15 Subpart C Section 15.207       | Mode 1          | FCC 15.207 | PASS   |
| Emissions in restricted frequency bands     | FCC CFR Title 47 Part 15 Subpart C Section 15.209       | Mode 1          | FCC 15.209 | PASS   |
| Emissions in non-restricted frequency bands | FCC CFR Title 47 Part 15 Subpart C Section 15.247(d)    | Mode 1          | 20dBc      | PASS   |
| Radiated Emission Band Edge                 | FCC CFR Title 47 Part 15 Subpart C 15.247(d)            | Mode 1          | FCC 15.209 | PASS   |
| Occupied Bandwidth                          | FCC CFR Title 47 Part 15 Subpart C Section 15.247(a)(2) | Mode 1          | 500kHz     | PASS   |
| Fundamental emission output power           | FCC CFR Title 47 Part 15 Subpart C Section 15.247(b)(3) | Mode 1          | 30dBm      | PASS   |
| Power Spectral Density                      | FCC CFR Title 47 Part 15 Subpart C Section 15.247(e)    | Mode 1          | 8dBm/3kHz  | PASS   |
| Antenna Requirement                         | FCC CFR Title 47 Part 15 Subpart C Section 15.203       | N/A             | FCC 15.203 | PASS   |

**ISED:**

| Performed Test Item                               | Normative References              | Worse case mode | Limit     | Result |
|---|-----------------------------------|-----------------|-----------|--------|
| AC Power Line<br>Conducted Emission               | RSS-Gen Issue 5<br>Section 8.8    | N/A             | RSS-Gen   | PASS   |
| Emissions in restricted<br>frequency bands        | RSS-Gen Issue 5<br>Section 8.10   | Mode1           | RSS-247   | PASS   |
| Emissions in<br>non-restricted frequency<br>bands | RSS-247 Issue 2<br>Section 5.5    | Mode1           | 30dBc     | PASS   |
| Radiated Emission Band<br>Edge                    | RSS-Gen Issue 5<br>Section 8.10   | Mode1           | RSS-Gen   | PASS   |
| Occupied Bandwidth                                | RSS-Gen Issue 5<br>Section 6.7    | Mode1           | 500kHz    | PASS   |
| Fundamental emission<br>output power              | RSS-247 Issue 2<br>Section 5.4(d) | Mode1           | 30dBm     | PASS   |
| Power Spectral Density                            | RSS-247 Issue 2<br>Section 5.2(b) | Mode1           | 8dBm/3kHz | PASS   |
| Antenna Requirement                               | RSS-Gen Issue 5<br>Section 6.8    | N/A             | RSS-Gen   | PASS   |

## 2.2. Test Environment

| Items                      | Required (IEC 68-1) | Actual   |
|----------------------------|---------------------|----------|
| Temperature (°C)           | 15-35               | 21       |
| Humidity (%RH)             | 25-75               | 50       |
| Barometric pressure (mbar) | 860-1060            | 950-1000 |

## 2.3. Measurement Uncertainty

| Test Items                         | Uncertainty         |
|------------------------------------|---------------------|
| AC Power Line Conducted Emission   | ± 2.02dB            |
| Radiated Emission                  | Below 1GHz ± 3.8 dB |
|                                    | Above 1GHz ± 3.9 dB |
| RF Antenna Port Conducted Emission | ± 1.27dB            |
| Radiated Emission Band Edge        | ± 3.9dB             |
| Occupied Bandwidth                 | ± 1kHz              |
| Power Spectral Density             | ± 1.27dB            |

### 3. AC Power Line Conducted Emission

#### 3.1. Test Equipment

| AC Power Line Conducted Emission / TR-1 |              |          |            |            |               |
|---|--------------|----------|------------|------------|---------------|
| Instrument                              | Manufacturer | Type No. | Serial No. | Cal. Date  | Cal. Due Date |
| EMI Test Receiver                       | R&S          | ESCI     | 100906     | 2019.03.05 | 2020.03.04    |
| Two-Line V-Network                      | R&S          | ENV 216  | 101189     | 2019.07.16 | 2020.07.15    |
| Two-Line V-Network                      | R&S          | ENV 216  | 101044     | 2018.09.16 | 2019.09.15    |
| 50ohm Coaxial Switch                    | Anritsu      | MP59B    | 6200464462 | N/A        | N/A           |
| 50ohm Termination                       | SHX          | TF2      | 07081402   | 2018.09.16 | 2019.09.15    |
| Temperature/Humidity Meter              | Zhichen      | ZC1-2    | TR1-TH     | 2019.01.05 | 2020.01.04    |

Note: All equipments are calibrated with traceable calibrations. Each calibration is traceable to the national or international standards.

#### 3.2. Test Setup

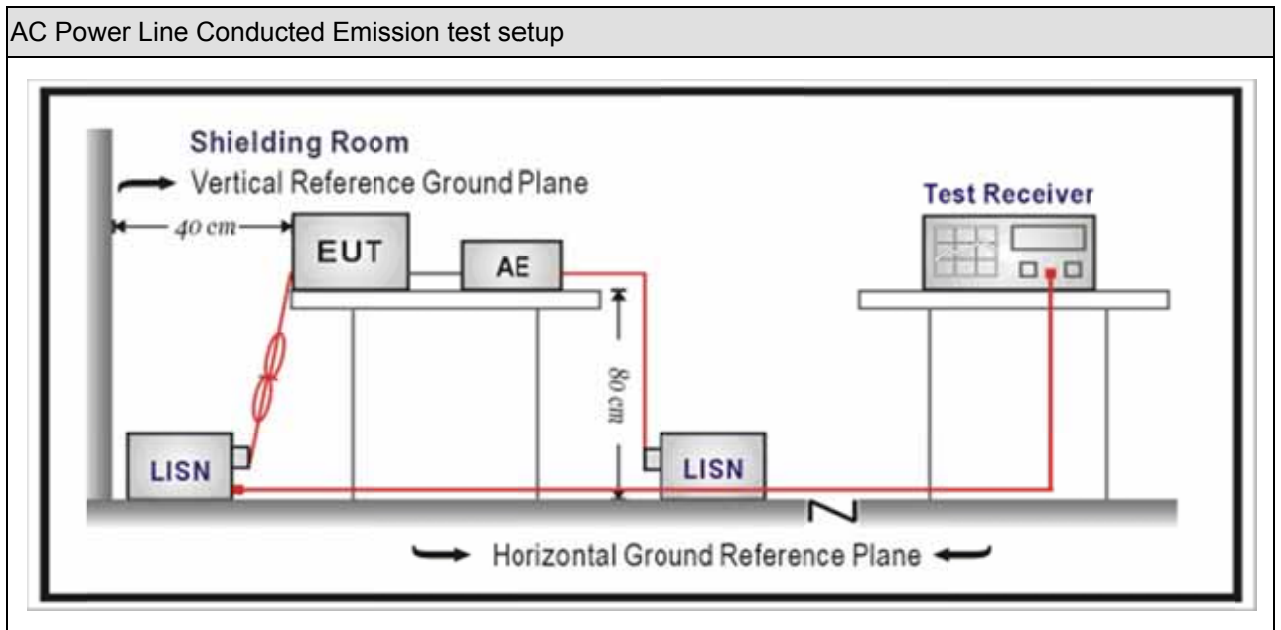

### 3.3. Limit

| Frequency of Emission<br>(MHz) | Conducted Limit         |                     |
|--------------------------------|-------------------------|---------------------|
|                                | Quasi-peak (dB $\mu$ V) | Average(dB $\mu$ V) |
| 0.15-0.5                       | 66 to 56                | 56 to 46            |
| 0.5-5                          | 56                      | 46                  |
| 5-30                           | 60                      | 50                  |

Note 1: The lower limit shall apply at the transition frequencies.  
 Note 2: The limit decreases linearly with the logarithm of the frequency in the range 0.15 MHz to 0.5 MHz.

### 3.4. Test Procedure

| Test Method                         |                  |         |   |
|-------------------------------------|------------------|---------|---|
|                                     | References Rule  | Chapter | Item  |
| <input checked="" type="checkbox"/> | ANSI C63.10-2013 | 6.2     | Standard test method for ac power-line conducted emissions from unlicensed wireless devices |
| <input checked="" type="checkbox"/> | ANSI C63.4-2014  | 7       | AC power-line conducted emission measurements   |

### 3.5. Test Result

|  |                          |
|--|--------------------------|
| Engineer: Xu Jun                         |                          |
| Site: TR1                                | Time: 2019/04/13 - 11:10 |
| Limit: FCC_Part15.107_CE_AC Power_ClassB | Margin: 0                |
| Probe: ENV216_101190(0.009-30MHz)        | Polarity: Neutral        |
| EUT: LED lamp                            | Power: AC 120V/60Hz      |
| Note: Mode 1:Transmit by Zigbee 1        |                          |

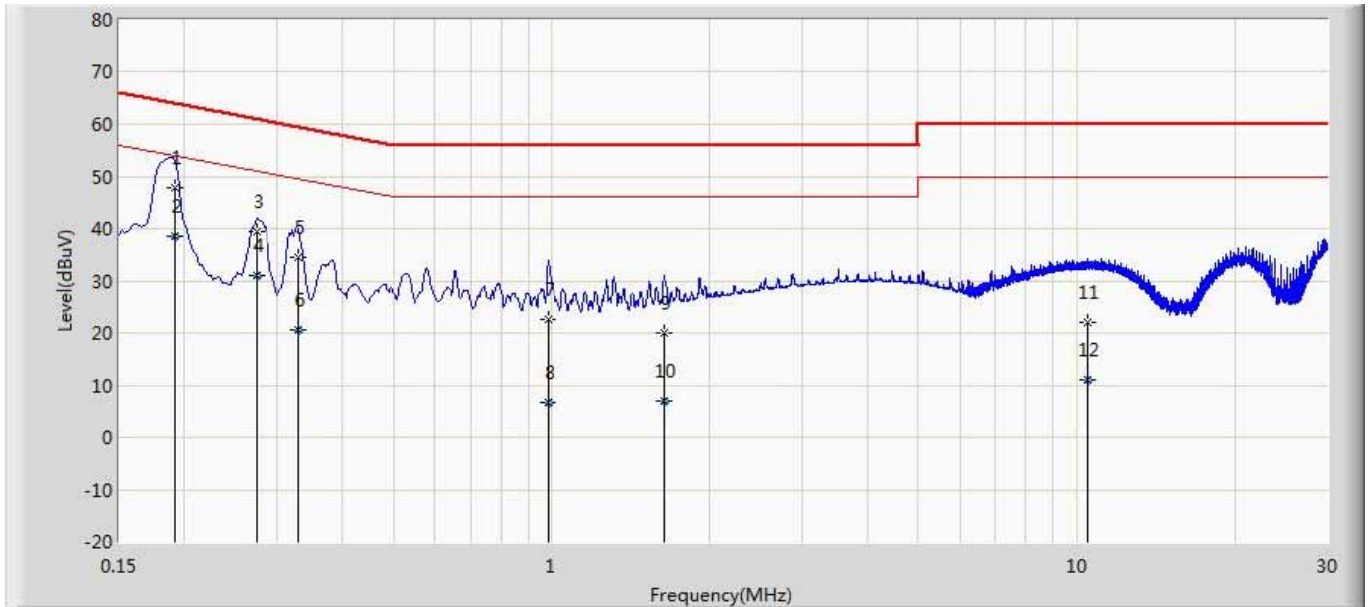

| No | Mark | Frequency (MHz) | Measure Level (dBuV) | Reading Level (dBuV) | Over Limit (dB) | Limit (dBuV) | Factor (dB) | Type |
|----|------|-----------------|----------------------|----------------------|-----------------|--------------|-------------|------|
| 1  |      | 0.192           | 47.969               | 38.343               | -15.965         | 63.934       | 9.626       | QP   |
| 2  | *    | 0.192           | 38.428               | 28.802               | -15.506         | 53.934       | 9.626       | AV   |
| 3  |      | 0.274           | 39.312               | 29.682               | -21.692         | 61.003       | 9.630       | QP   |
| 4  |      | 0.274           | 31.005               | 21.375               | -19.999         | 51.003       | 9.630       | AV   |
| 5  |      | 0.330           | 34.562               | 24.933               | -24.890         | 59.451       | 9.628       | QP   |
| 6  |      | 0.330           | 20.644               | 11.016               | -28.807         | 49.451       | 9.628       | AV   |
| 7  |      | 0.985           | 22.602               | 12.954               | -33.398         | 56.000       | 9.647       | QP   |
| 8  |      | 0.985           | 6.663                | -2.984               | -39.337         | 46.000       | 9.647       | AV   |
| 9  |      | 1.637           | 19.913               | 10.235               | -36.087         | 56.000       | 9.678       | QP   |
| 10 |      | 1.637           | 6.881                | -2.797               | -39.119         | 46.000       | 9.678       | AV   |
| 11 |      | 10.469          | 21.980               | 11.966               | -38.020         | 60.000       | 10.014      | QP   |
| 12 |      | 10.469          | 10.886               | 0.872                | -39.114         | 50.000       | 10.014      | AV   |



|  |                          |
|--|--------------------------|
| Engineer: Xu Jun                         |                          |
| Site: TR1                                | Time: 2019/08/20 - 23:59 |
| Limit: FCC_Part15.107_CE_AC Power_ClassB | Margin: 0                |
| Probe: ENV216_101190(0.009-30MHz)        | Polarity: Line           |
| EUT: LED lamp                            | Power: AC 120V/60Hz      |
| Note: Mode 1:Transmit by Zigbee 1        |                          |

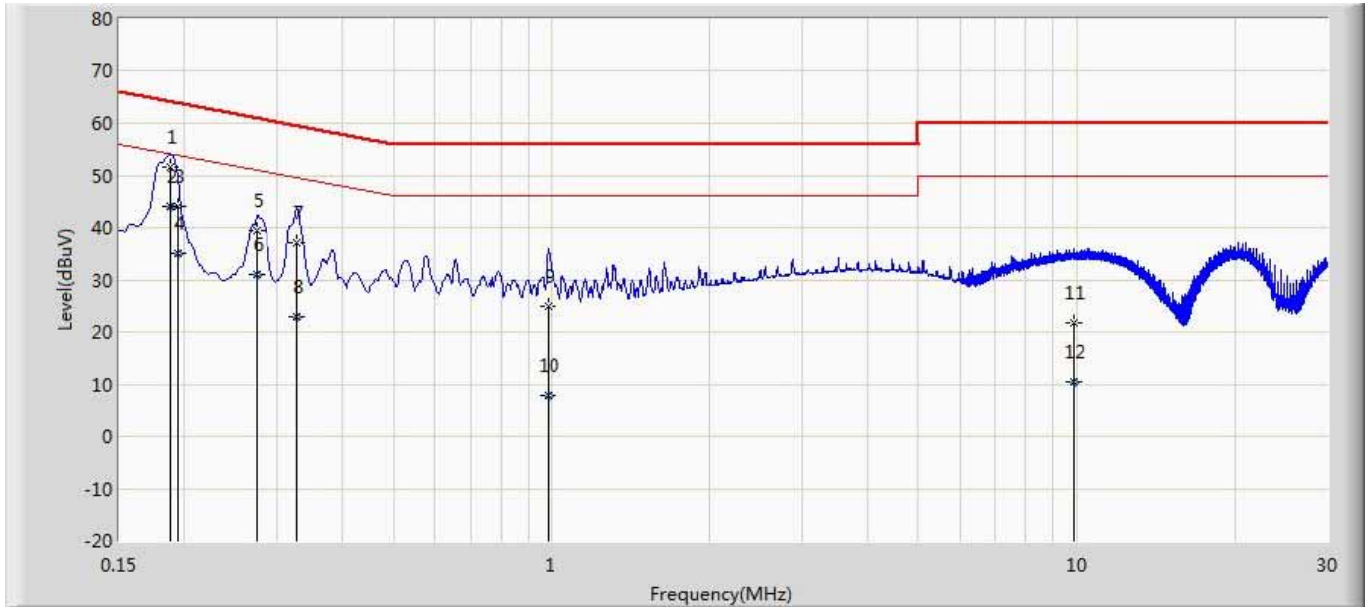

| No | Mark | Frequency (MHz) | Measure Level (dBuV) | Reading Level (dBuV) | Over Limit (dB) | Limit (dBuV) | Factor (dB) | Type |
|----|------|-----------------|----------------------|----------------------|-----------------|--------------|-------------|------|
| 1  |      | 0.188           | 51.516               | 41.887               | -12.597         | 64.113       | 9.629       | QP   |
| 2  | *    | 0.188           | 44.043               | 34.413               | -10.071         | 54.113       | 9.629       | AV   |
| 3  |      | 0.194           | 44.108               | 34.477               | -19.757         | 63.865       | 9.631       | QP   |
| 4  |      | 0.194           | 35.002               | 25.371               | -18.863         | 53.865       | 9.631       | AV   |
| 5  |      | 0.274           | 39.389               | 29.757               | -21.614         | 61.003       | 9.633       | QP   |
| 6  |      | 0.274           | 31.109               | 21.476               | -19.895         | 51.003       | 9.633       | AV   |
| 7  |      | 0.328           | 37.014               | 27.381               | -22.494         | 59.508       | 9.633       | QP   |
| 8  |      | 0.328           | 22.788               | 13.156               | -26.720         | 49.508       | 9.633       | AV   |
| 9  |      | 0.985           | 24.922               | 15.255               | -31.078         | 56.000       | 9.667       | QP   |
| 10 |      | 0.985           | 7.761                | -1.905               | -38.239         | 46.000       | 9.667       | AV   |
| 11 |      | 9.841           | 21.601               | 11.631               | -38.399         | 60.000       | 9.970       | QP   |
| 12 |      | 9.841           | 10.421               | 0.451                | -39.579         | 50.000       | 9.970       | AV   |

**Note:**

1. " \* ", means this data is the worst emission level.
2. Measurement Level = Reading Level + Factor(Probe+Cable-Amp).

|  |                          |
|--|--------------------------|
| Engineer: Xu Jun                         |                          |
| Site: TR1                                | Time: 2019/08/21 - 00:06 |
| Limit: FCC_Part15.107_CE_AC Power_ClassB | Margin: 0                |
| Probe: ENV216_101190(0.009-30MHz)        | Polarity: Neutral        |
| EUT: LED lamp                            | Power: AC 120V/60Hz      |
| Note: Mode 3:Transmit by Zibgee 2        |                          |

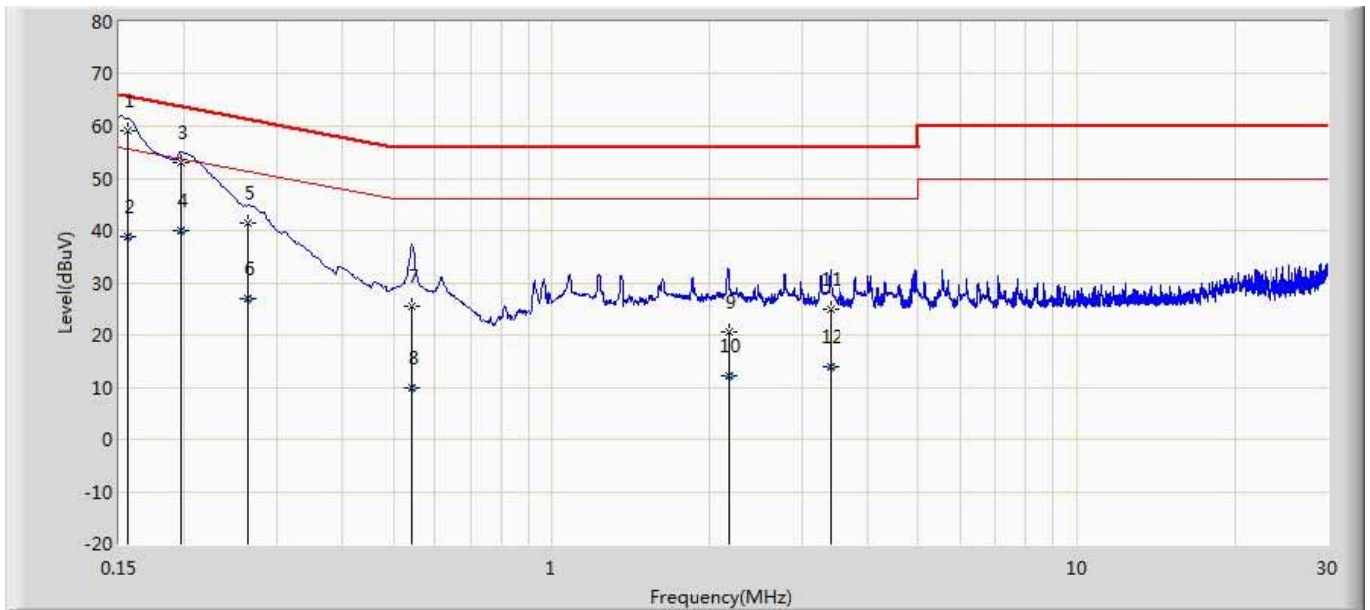

| No | Mark | Frequency (MHz) | Measure Level (dBuV) | Reading Level (dBuV) | Over Limit (dB) | Limit (dBuV) | Factor (dB) | Type |
|----|------|-----------------|----------------------|----------------------|-----------------|--------------|-------------|------|
| 1  | *    | 0.156           | 59.204               | 49.589               | -6.452          | 65.656       | 9.615       | QP   |
| 2  |      | 0.156           | 38.899               | 29.284               | -16.757         | 55.656       | 9.615       | AV   |
| 3  |      | 0.197           | 53.172               | 43.544               | -10.554         | 63.726       | 9.628       | QP   |
| 4  |      | 0.197           | 40.098               | 30.470               | -13.627         | 53.726       | 9.628       | AV   |
| 5  |      | 0.263           | 41.464               | 31.835               | -19.888         | 61.352       | 9.630       | QP   |
| 6  |      | 0.263           | 27.025               | 17.395               | -24.327         | 51.352       | 9.630       | AV   |
| 7  |      | 0.541           | 25.516               | 15.877               | -30.484         | 56.000       | 9.639       | QP   |
| 8  |      | 0.541           | 9.886                | 0.247                | -36.114         | 46.000       | 9.639       | AV   |
| 9  |      | 2.175           | 20.600               | 10.892               | -35.400         | 56.000       | 9.707       | QP   |
| 10 |      | 2.175           | 12.275               | 2.568                | -33.725         | 46.000       | 9.707       | AV   |
| 11 |      | 3.390           | 24.826               | 15.080               | -31.174         | 56.000       | 9.746       | QP   |
| 12 |      | 3.390           | 13.880               | 4.134                | -32.120         | 46.000       | 9.746       | AV   |

|  |                          |
|--|--------------------------|
| Engineer: Xu Jun                         |                          |
| Site: TR1                                | Time: 2019/08/21 - 00:11 |
| Limit: FCC_Part15.107_CE_AC Power_ClassB | Margin: 0                |
| Probe: ENV216_101190(0.009-30MHz)        | Polarity: Line           |
| EUT: LED lamp                            | Power: AC 120V/60Hz      |
| Note: Mode 3:Transmit by Zibgee 2        |                          |

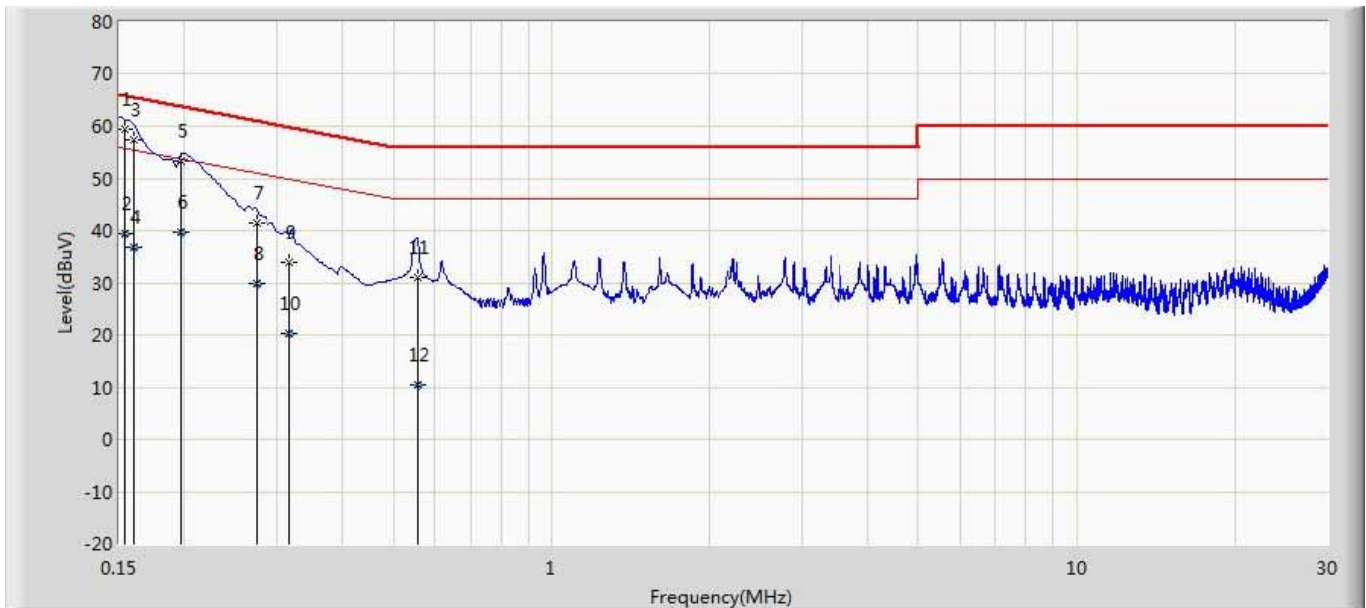

| No | Mark | Frequency (MHz) | Measure Level (dBuV) | Reading Level (dBuV) | Over Limit (dB) | Limit (dBuV) | Factor (dB) | Type |
|----|------|-----------------|----------------------|----------------------|-----------------|--------------|-------------|------|
| 1  | *    | 0.154           | 59.468               | 49.838               | -6.286          | 65.754       | 9.631       | QP   |
| 2  |      | 0.154           | 39.397               | 29.766               | -16.358         | 55.754       | 9.631       | AV   |
| 3  |      | 0.160           | 57.506               | 47.876               | -7.943          | 65.449       | 9.630       | QP   |
| 4  |      | 0.160           | 36.787               | 27.157               | -18.662         | 55.449       | 9.630       | AV   |
| 5  |      | 0.197           | 53.305               | 43.674               | -10.421         | 63.726       | 9.631       | QP   |
| 6  |      | 0.197           | 39.711               | 30.080               | -14.015         | 53.726       | 9.631       | AV   |
| 7  |      | 0.274           | 41.331               | 31.698               | -19.672         | 61.003       | 9.633       | QP   |
| 8  |      | 0.274           | 29.730               | 20.097               | -21.273         | 51.003       | 9.633       | AV   |
| 9  |      | 0.317           | 33.823               | 24.191               | -25.975         | 59.798       | 9.632       | QP   |
| 10 |      | 0.317           | 20.170               | 10.538               | -29.628         | 49.798       | 9.632       | AV   |
| 11 |      | 0.555           | 31.010               | 21.364               | -24.990         | 56.000       | 9.647       | QP   |
| 12 |      | 0.555           | 10.340               | 0.693                | -35.660         | 46.000       | 9.647       | AV   |

**Note:**

1. " \* ", means this data is the worst emission level.
2. Measurement Level = Reading Level + Factor(Probe+Cable-Amp).

## 4. Emissions in restricted frequency bands

### 4.1. Test Equipment

| Radiated Emission(Below 1GHz) / AC-2   |              |                 |            |            |               |
|--|--------------|-----------------|------------|------------|---------------|
| Instrument   | Manufacturer | Type No.        | Serial No. | Cal. Date  | Cal. Due Date |
| EMI Test Receiver  | R&S          | ESCI            | 100573     | 2019.03.29 | 2020.03.28    |
| Loop Antenna   | R&S          | HFH2-Z2         | 833799/003 | 2018.11.16 | 2019.11.15    |
| Bilog Antenna  | Teseq GmbH   | CBL6112D        | 27611      | 2018.10.16 | 2019.10.15    |
| Coaxial Cable  | Huber+Suhner | SUCOFLEX<br>106 | AC2-C      | 2019.03.02 | 2020.03.01    |
| Temperature/Humidity<br>Meter  | Zhichen      | ZC1-2           | AC2-TH     | 2019.01.04 | 2020.01.03    |
| Note: All equipments are calibrated with traceable calibrations. Each calibration is traceable to the national or international standards. |              |                 |            |            |               |

| Radiated Emission(Above 1GHz) / AC-5   |              |                 |             |            |               |
|--|--------------|-----------------|-------------|------------|---------------|
| Instrument   | Manufacturer | Type No.        | Serial No.  | Cal. Date  | Cal. Due Date |
| Spectrum Analyzer  | Agilent      | E4446A          | MY45300103  | 2019.01.04 | 2020.01.03    |
| Preamplifier   | Miteq        | NSP1800-25      | 1364185     | 2019.05.06 | 2020.05.05    |
| Preamplifier   | QuieTek      | AP-040G         | CHM-0906001 | 2019.05.06 | 2020.05.05    |
| DRG Horn   | ETS-Lindgren | 3117            | 00123988    | 2019.01.22 | 2020.01.21    |
| Broad-Band Horn<br>Antenna   | Schwarzbeck  | BBHA9170        | 294         | 2018.11.25 | 2019.11.24    |
| Coaxial Cable  | Huber+Suhner | SUCOFLEX<br>106 | AC5-C1      | 2019.03.02 | 2020.03.01    |
| Coaxial Cable  | Huber+Suhner | SUCOFLEX<br>106 | AC5-C2      | 2019.03.02 | 2020.03.01    |
| Coaxial Cable  | Huber+Suhner | SUCOFLEX<br>102 | AC5-C3      | 2019.03.02 | 2020.03.01    |
| EMI Receiver   | Agilent      | N9038A          | MY51210196  | 2019.06.10 | 2020.06.09    |
| Temperature/Humidity<br>Meter  | Zhichen      | ZC1-2           | AC5-TH      | 2019.01.04 | 2020.01.03    |
| Note: All equipments are calibrated with traceable calibrations. Each calibration is traceable to the national or international standards. |              |                 |             |            |               |

### 4.2. Test Setup

Below 30MHz Test Setup:

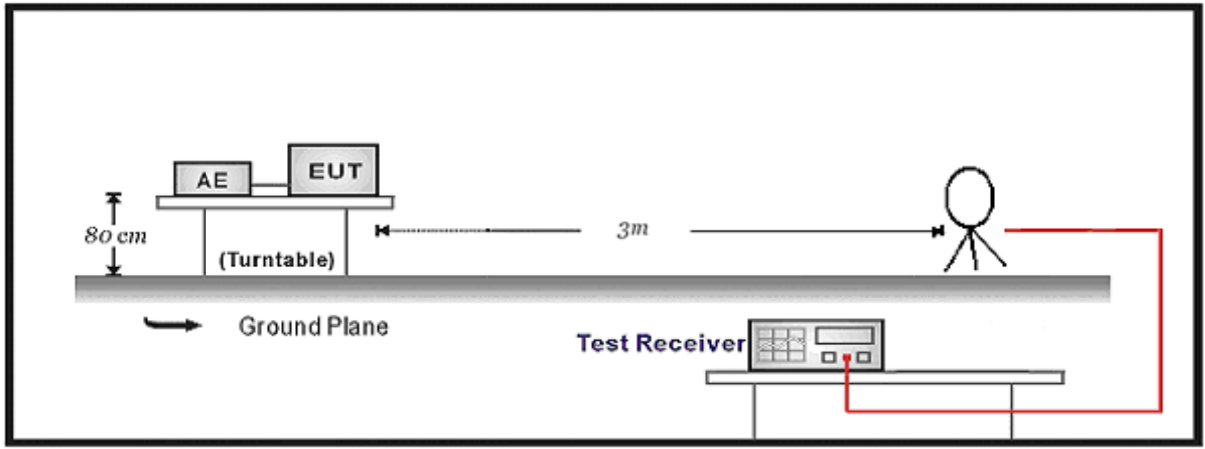

30MHz-1GHz Test Setup:

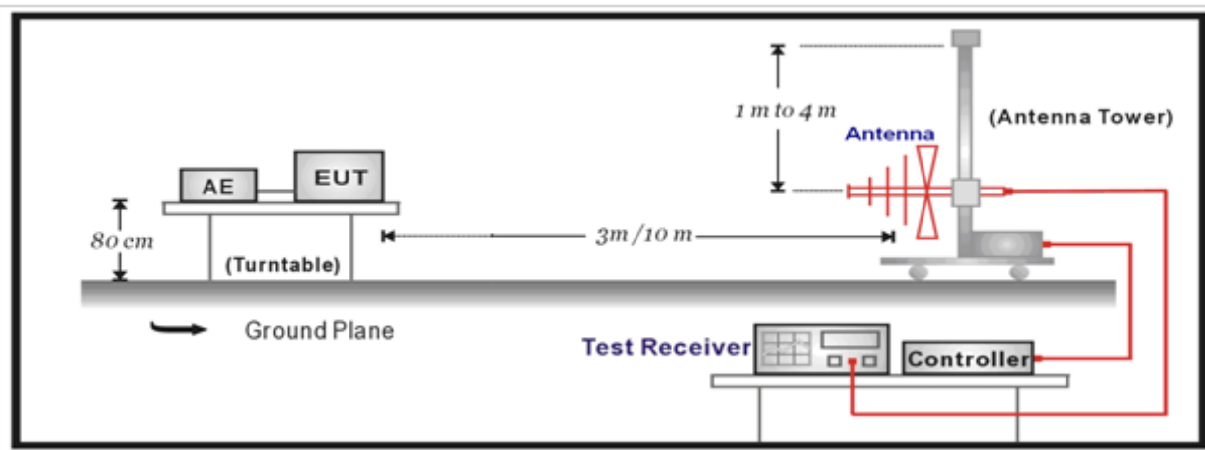

Above 1GHz Test Setup:

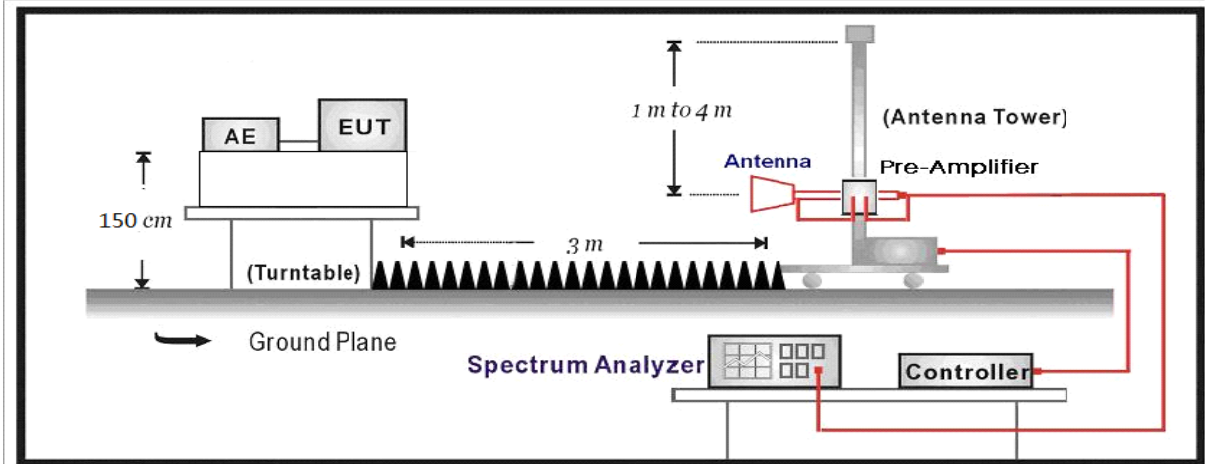

**4.3. Limit**

**For FCC:**

| Restricted Bands of operation |                       |                 |                 |
|-------------------------------|-----------------------|-----------------|-----------------|
| Frequency (MHz)               | Frequency (MHz)       | Frequency (MHz) | Frequency (GHz) |
| 0.090 – 0.110                 | 16.42 – 16.423        | 399.9 – 410     | 4.5 – 5.15      |
| 0.495 – 0.505                 | 16.69475 – 16.69525   | 608 – 614       | 5.35 – 5.46     |
| 2.1735 – 2.1905               | 16.80425 – 16.80475   | 960 – 1240      | 7.25 – 7.75     |
| 4.125 – 4.128                 | 25.5 – 25.67          | 1300 – 1427     | 8.025 – 8.5     |
| 4.17725 – 4.17775             | 37.5 – 38.25          | 1435 – 1626.5   | 9.0 – 9.2       |
| 4.20725 – 4.20775             | 73 – 74.6             | 1645.5 – 1646.5 | 9.3 – 9.5       |
| 6.215 – 6.218                 | 74.8 – 75.2           | 1660 – 1710     | 10.6 – 12.7     |
| 6.26775 – 6.26825             | 108 – 121.94          | 1718.8 – 1722.2 | 13.25 – 13.4    |
| 6.31175 – 6.31225             | 123 – 138             | 2200 – 2300     | 14.47 – 14.5    |
| 8.291 – 8.294                 | 149.9 – 150.05        | 2310 – 2390     | 15.35 – 16.2    |
| 8.362 – 8.366                 | 156.52475 – 156.52525 | 2483.5 – 2500   | 17.7 – 21.4     |
| 8.37625 – 8.38675             | 156.7 – 156.9         | 2690 – 2900     | 22.01 – 23.12   |
| 8.81425 – 8.81475             | 162.0125 – 167.17     | 3260 – 3267     | 23.6 – 24.0     |
| 12.29 – 12.293                | 167.72 – 173.2        | 3332 – 3339     | 31.2 – 31.8     |
| 12.51975 – 12.52025           | 240 – 285             | 3345.8 – 3358   | 36.43 – 36.5    |
| 12.57675 – 12.57725           | 322 – 335.4           | 3600 – 4400     |                 |
| 13.36 – 13.41                 |                       |                 |                 |

**For ISED:**

| Restricted Bands of operation |                       |                 |                 |
|-------------------------------|-----------------------|-----------------|-----------------|
| Frequency (MHz)               | Frequency (MHz)       | Frequency (MHz) | Frequency (GHz) |
|                               | 13.36 - 13.41         | 960 - 1427      | 9.0 - 9.2       |
| 0.495 - 0.505                 | 16.42 - 16.423        | 1435 - 1626.5   | 9.3 - 9.5       |
| 2.1735 - 2.1905               | 16.69475 - 16.69525   | 1645.5 - 1646.5 | 10.6 - 12.7     |
| 3.020 - 3.026                 | 16.80425 - 16.80475   | 1660 - 1710     | 13.25 - 13.4    |
| 4.125 - 4.128                 | 25.5 - 25.67          | 1718.8 - 1722.2 | 14.47 - 14.5    |
| 4.17725 - 4.17775             | 37.5 - 38.25          | 2200 - 2300     | 15.35 - 16.2    |
| 4.20725 - 4.20775             | 73 - 74.6             | 2310 - 2390     | 17.7 - 21.4     |
| 5.677 - 5.683                 | 74.8 - 75.2           | 2483.5 - 2500   | 22.01 - 23.12   |
| 6.215 - 6.218                 | 108 - 138             | 2655 - 2900     | 23.6 - 24.0     |
| 6.26775 - 6.26825             | 149.9 - 150.05        | 3260 - 3267     | 31.2 - 31.8     |
| 6.31175 - 6.31225             | 156.52475 - 156.52525 | 3332 - 3339     | 36.43 - 36.5    |
| 8.291 - 8.294                 | 156.7 - 156.9         | 3345.8 - 3358   | Above 38.6      |
| 8.362 - 8.366                 | 162.0125 - 167.17     | 3500 - 4400     |                 |
| 8.37625 - 8.38675             | 167.72 - 173.2        | 4500 - 5150     |                 |
| 8.41425 - 8.41475             | 240 - 285             | 5350 - 5460     |                 |
| 12.29 - 12.293                | 322 - 335.4           | 7250 - 7750     |                 |
| 12.51975 - 12.52025           | 399.9 - 410           | 8025 - 8500     |                 |
| 12.57675 - 12.57725           | 608 - 614             | --              |                 |

| Restricted Band Emissions Limit |                        |                           |                          |
|---------------------------------|------------------------|---------------------------|--------------------------|
| Frequency (MHz)                 | Field strength (μ V/m) | Field strength (dB μ V/m) | Measurement distance (m) |
| 0.009 - 0.49                    | 2400/F(kHz)            | 48.5 – 13.8               | 300 <sub>(Note 1)</sub>  |
| 0.49 - 1.705                    | 24000/F(kHz)           | 33.8 - 23                 | 30 <sub>(Note 1)</sub>   |
| 1.705 - 30                      | 30                     | 29.5                      | 30 <sub>(Note 1)</sub>   |
| 30 - 88                         | 100                    | 40                        | 3 <sub>(Note 2)</sub>    |
| 88 - 216                        | 150                    | 43.5                      | 3 <sub>(Note 2)</sub>    |
| 216 - 960                       | 200                    | 46                        | 3 <sub>(Note 2)</sub>    |
| Above 960                       | 500                    | 54                        | 3 <sub>(Note 2)</sub>    |

Note 1: At frequencies below 30 MHz, measurements may be performed at a distance closer than that specified in the regulations; however, an attempt should be made to avoid making measurements in the near field. Pending the development of an appropriate measurement procedure for measurements performed below 30 MHz, when performing measurements at a closer distance than specified, the results shall be extrapolated to the specified distance by either making measurements at a minimum of two distances on at least one radial to determine the proper extrapolation factor or by using the square of an inverse linear distance extrapolation factor (40 dB/decade).



Note 2: At frequencies at or above 30 MHz, measurements may be performed at a distance other than what is specified provided: measurements are not made in the near field except where it can be shown that near field measurements are appropriate due to the characteristics of the device; and it can be demonstrated that the signal levels needed to be measured at the distance employed can be detected by the measurement equipment. Measurements shall not be performed at a distance greater than 30 meters unless it can be further demonstrated that measurements at a distance of 30 meters or less are impractical. When performing measurements at a distance other than that specified, the results shall be extrapolated to the specified distance using an extrapolation factor of 20 dB/decade (inverse linear-distance for field strength measurements; inverse-linear-distance-squared for power density measurements).



**4.4. Test Procedure**

| Test Method                         |   |             |  |
|-------------------------------------|---|-------------|--|
|                                     | References Rule                                 | Chapter     | Description  |
| <input type="checkbox"/>            | ANSI C63.10                                     | 11.11       | Emissions in non-restricted frequency bands  |
|                                     | <input type="checkbox"/> ANSI C63.10            | 11.11.2     | Reference level measurement  |
|                                     | <input type="checkbox"/> ANSI C63.10            | 11.11.3     | Emission level measurement   |
| <input checked="" type="checkbox"/> | ANSI C63.10                                     | 11.12       | Emissions in restricted frequency bands  |
|                                     | <input checked="" type="checkbox"/> ANSI C63.10 | 11.12.1     | Radiated emission measurements   |
|                                     | <input checked="" type="checkbox"/> ANSI C63.10 | 11.12.2.7   | Radiated spurious emission test  |
|                                     | <input checked="" type="checkbox"/> ANSI C63.10 | 6.4         | Radiated emissions from unlicensed wireless devices below 30 MHz                                   |
|                                     | <input checked="" type="checkbox"/> ANSI C63.10 | 6.5         | Radiated emissions from unlicensed wireless devices in the frequency range of 30 MHz to 1000 MHz   |
|                                     | <input checked="" type="checkbox"/> ANSI C63.10 | 6.6         | Radiated emissions from unlicensed wireless devices above 1 GHz                                    |
|                                     | <input type="checkbox"/> ANSI C63.10            | 11.12.2.3   | Quasi-peak measurement procedure   |
|                                     | <input type="checkbox"/> ANSI C63.10            | 11.12.2.4   | Peak power measurement procedure   |
|                                     | <input type="checkbox"/> ANSI C63.10            | 11.12.2.5   | Average power measurement procedures   |
|                                     | <input type="checkbox"/> ANSI C63.10            | 11.12.2.5.1 | Trace averaging with continuous EUT transmission at full power                                     |
|                                     | <input type="checkbox"/> ANSI C63.10            | 11.12.2.5.2 | Trace averaging across ON and OFF times of the EUT transmissions followed by duty cycle correction |
|                                     | <input type="checkbox"/> ANSI C63.10            | 11.12.2.5.3 | Reduced VBW averaging across ON and OFF times of the EUT transmissions with max hold               |

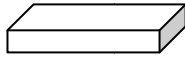
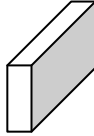
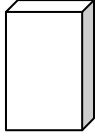
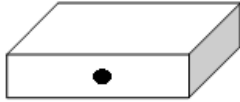
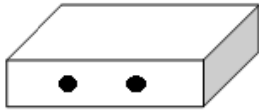
**4.5. EUT test Axis definition**

| Item            | Emissions in restricted frequency bands  |  |  |  |
|-----------------|--|--|--|--|
| Device Category | <input type="checkbox"/>   | Fixed point-to-point   |  |  |
|                 | <input type="checkbox"/>   | Emit multiple directional beams, simultaneously or sequentially                      |  |  |
|                 | <input checked="" type="checkbox"/>  | Other cases  |  |  |
| Test mode       | Mode 1   |  |  |  |
| Test method     | <input checked="" type="checkbox"/>  | Radiated   |  |  |
|                 |  | X Axis   | Y Axis   | Z Axis   |
|                 |  |     |  |  |
|                 |  | Worst Axis <input checked="" type="checkbox"/>                                       | Worst Axis <input type="checkbox"/>  | Worst Axis <input type="checkbox"/>  |
|                 | <input type="checkbox"/>   | Conducted  |  |  |
|                 | <input type="checkbox"/>   | Chain 0  |  |  |
|                 |  |  |  |  |
|                 | <input type="checkbox"/>   | Chain 0  | Chain 1  |  |
|                 |  |  |  |  |
|                 | <input type="checkbox"/>   | Chain 0  | Chain 1  | Chain 2  |
|                 |  |  |  |  |

### 4.6. Test Result

**Muruta:**

|  |                          |
|--|--------------------------|
| Engineer: Tongben                          |                          |
| Site: AC5                                  | Time: 2019/08/17 - 16:58 |
| Limit: FCC_Part15.209_RE(3m)               | Margin: 0                |
| Probe: Horn_3117_00167055(1-18GHz)         | Polarity: Horizontal     |
| EUT: LED lamp                              | Power: AC 120V/60Hz      |
| Note: Mode 1:Transmit at 2405MHz by Zigbee |                          |

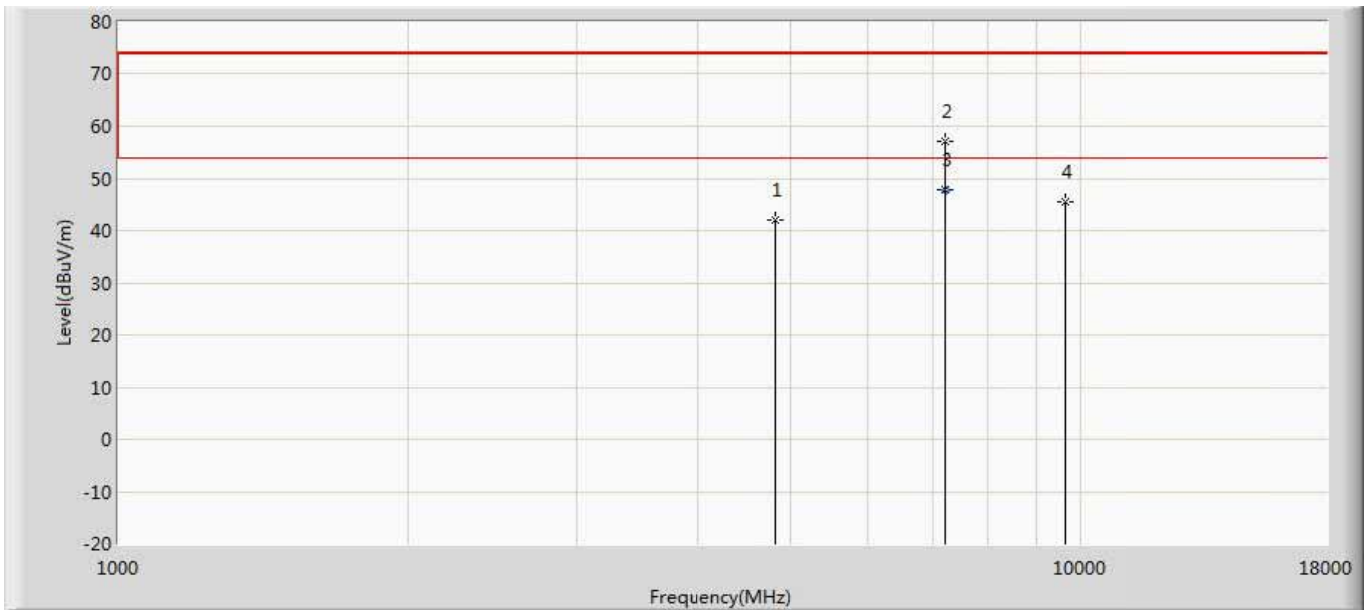

| No | Mark | Frequency (MHz) | Measure Level (dBuV/m) | Reading Level (dBuV) | Over Limit (dB) | Limit (dBuV/m) | Factor (dB) | Type |
|----|------|-----------------|------------------------|----------------------|-----------------|----------------|-------------|------|
| 1  |      | 4810.000        | 42.165                 | 37.660               | -31.835         | 74.000         | 4.505       | PK   |
| 2  |      | 7215.000        | 57.243                 | 49.685               | -16.757         | 74.000         | 7.557       | PK   |
| 3  | *    | 7215.000        | 47.951                 | 40.393               | -6.049          | 54.000         | 7.557       | AV   |
| 4  |      | 9620.000        | 45.402                 | 36.162               | -28.598         | 74.000         | 9.239       | PK   |

|  |                          |
|--|--------------------------|
| Engineer: Tongben                          |                          |
| Site: AC5                                  | Time: 2019/08/17 - 16:59 |
| Limit: FCC_Part15.209_RE(3m)               | Margin: 0                |
| Probe: Horn_3117_00167055(1-18GHz)         | Polarity: Vertical       |
| EUT: LED lamp                              | Power: AC 120V/60Hz      |
| Note: Mode 1:Transmit at 2405MHz by Zigbee |                          |

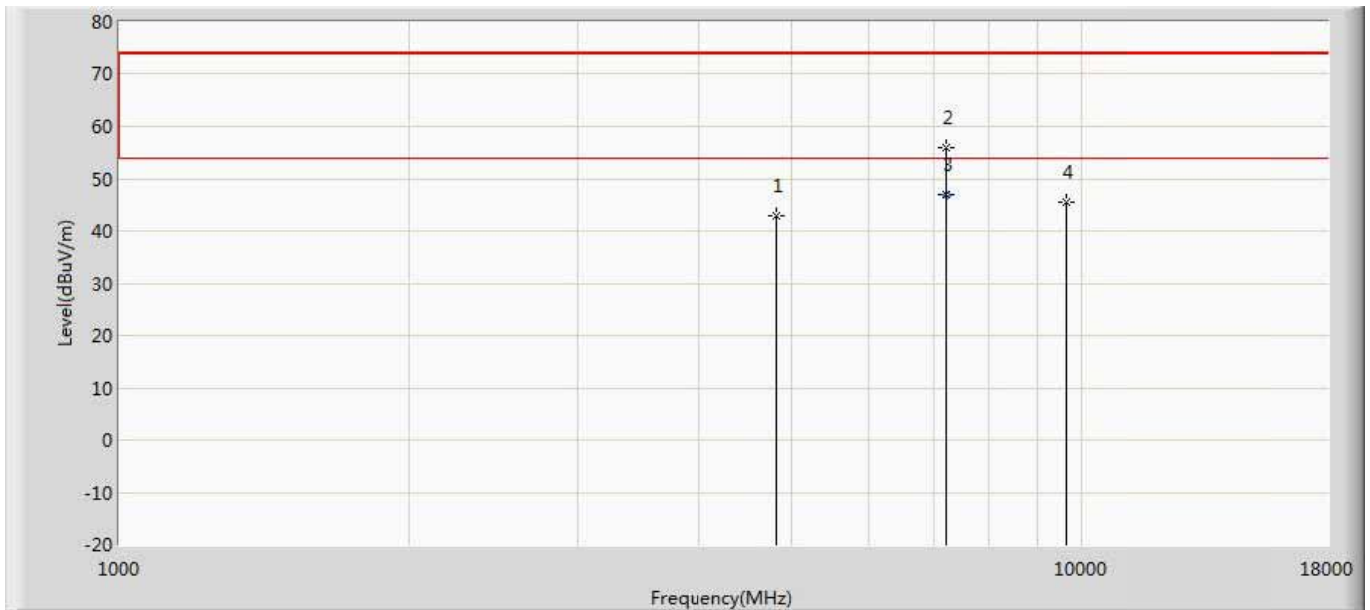

| No | Mark | Frequency (MHz) | Measure Level (dBuV/m) | Reading Level (dBuV) | Over Limit (dB) | Limit (dBuV/m) | Factor (dB) | Type |
|----|------|-----------------|------------------------|----------------------|-----------------|----------------|-------------|------|
| 1  |      | 4810.000        | 42.866                 | 38.361               | -31.134         | 74.000         | 4.505       | PK   |
| 2  |      | 7215.000        | 55.947                 | 48.389               | -18.053         | 74.000         | 7.557       | PK   |
| 3  | *    | 7215.000        | 46.976                 | 39.418               | -7.024          | 54.000         | 7.557       | AV   |
| 4  |      | 9620.000        | 45.472                 | 36.232               | -28.528         | 74.000         | 9.239       | PK   |

|  |                          |
|--|--------------------------|
| Engineer: Tongben                          |                          |
| Site: AC5                                  | Time: 2019/08/17 - 17:01 |
| Limit: FCC_Part15.209_RE(3m)               | Margin: 0                |
| Probe: Horn_3117_00167055(1-18GHz)         | Polarity: Horizontal     |
| EUT: LED lamp                              | Power: AC 120V/60Hz      |
| Note: Mode 1:Transmit at 2440MHz by Zigbee |                          |

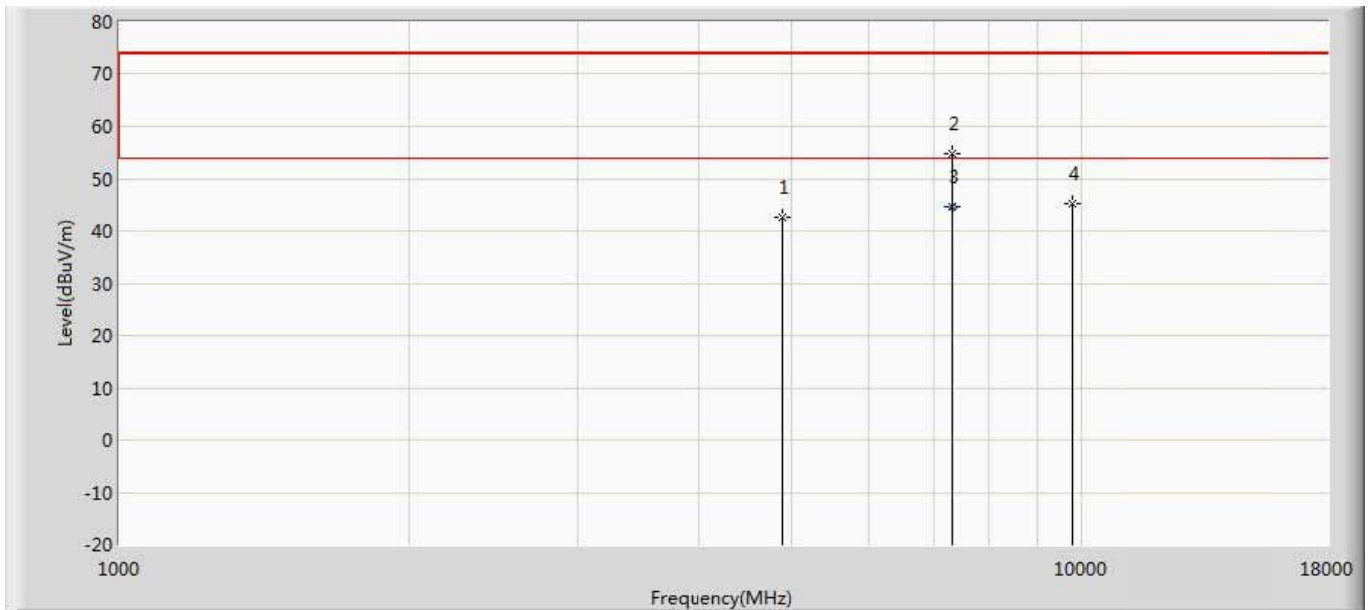

| No | Mark | Frequency (MHz) | Measure Level (dBuV/m) | Reading Level (dBuV) | Over Limit (dB) | Limit (dBuV/m) | Factor (dB) | Type |
|----|------|-----------------|------------------------|----------------------|-----------------|----------------|-------------|------|
| 1  |      | 4880.000        | 42.558                 | 37.772               | -31.442         | 74.000         | 4.786       | PK   |
| 2  |      | 7320.000        | 54.848                 | 47.186               | -19.152         | 74.000         | 7.663       | PK   |
| 3  | *    | 7320.000        | 44.659                 | 36.997               | -9.341          | 54.000         | 7.663       | AV   |
| 4  |      | 9760.000        | 45.209                 | 35.349               | -28.791         | 74.000         | 9.860       | PK   |

|  |                          |
|--|--------------------------|
| Engineer: Tongben                          |                          |
| Site: AC5                                  | Time: 2019/08/17 - 17:01 |
| Limit: FCC_Part15.209_RE(3m)               | Margin: 0                |
| Probe: Horn_3117_00167055(1-18GHz)         | Polarity: Vertical       |
| EUT: LED lamp                              | Power: AC 120V/60Hz      |
| Note: Mode 1:Transmit at 2440MHz by Zigbee |                          |

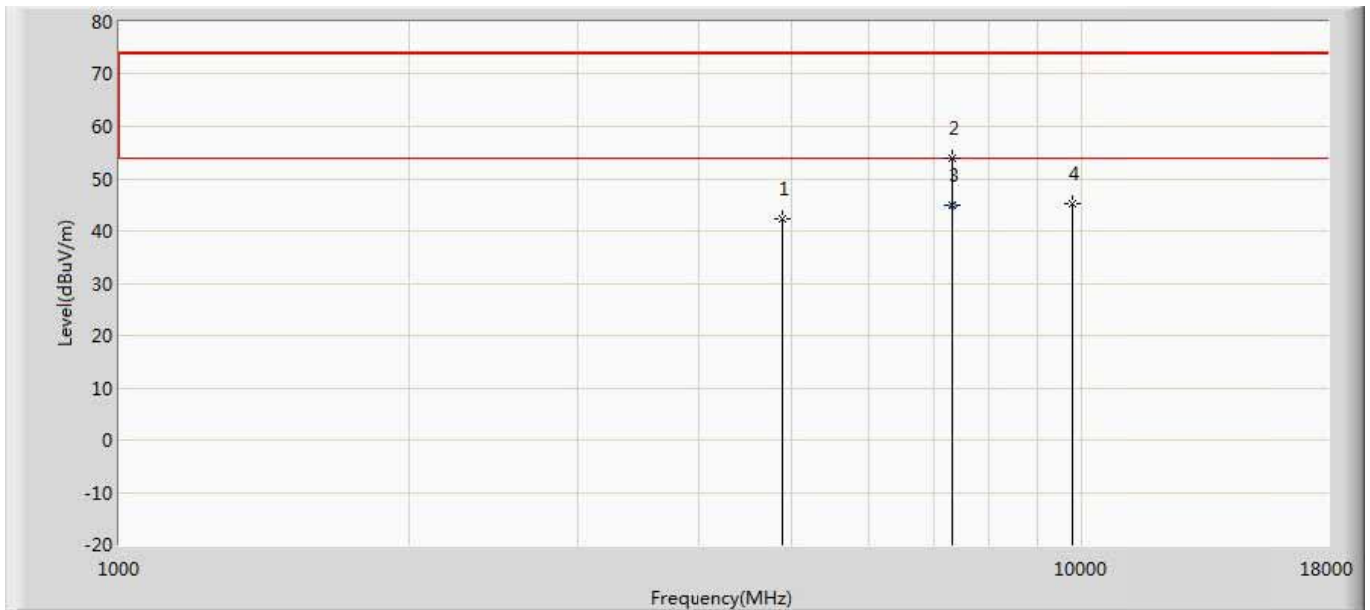

| No | Mark | Frequency (MHz) | Measure Level (dBuV/m) | Reading Level (dBuV) | Over Limit (dB) | Limit (dBuV/m) | Factor (dB) | Type |
|----|------|-----------------|------------------------|----------------------|-----------------|----------------|-------------|------|
| 1  |      | 4880.000        | 42.265                 | 37.479               | -31.735         | 74.000         | 4.786       | PK   |
| 2  |      | 7320.000        | 54.011                 | 46.349               | -19.989         | 74.000         | 7.663       | PK   |
| 3  | *    | 7320.000        | 44.832                 | 37.170               | -9.168          | 54.000         | 7.663       | AV   |
| 4  |      | 9760.000        | 45.321                 | 35.461               | -28.679         | 74.000         | 9.860       | PK   |

|  |                          |
|--|--------------------------|
| Engineer: Tongben                          |                          |
| Site: AC5                                  | Time: 2019/08/17 - 17:01 |
| Limit: FCC_Part15.209_RE(3m)               | Margin: 0                |
| Probe: Horn_3117_00167055(1-18GHz)         | Polarity: Horizontal     |
| EUT: LED lamp                              | Power: AC 120V/60Hz      |
| Note: Mode 1:Transmit at 2480MHz by Zigbee |                          |

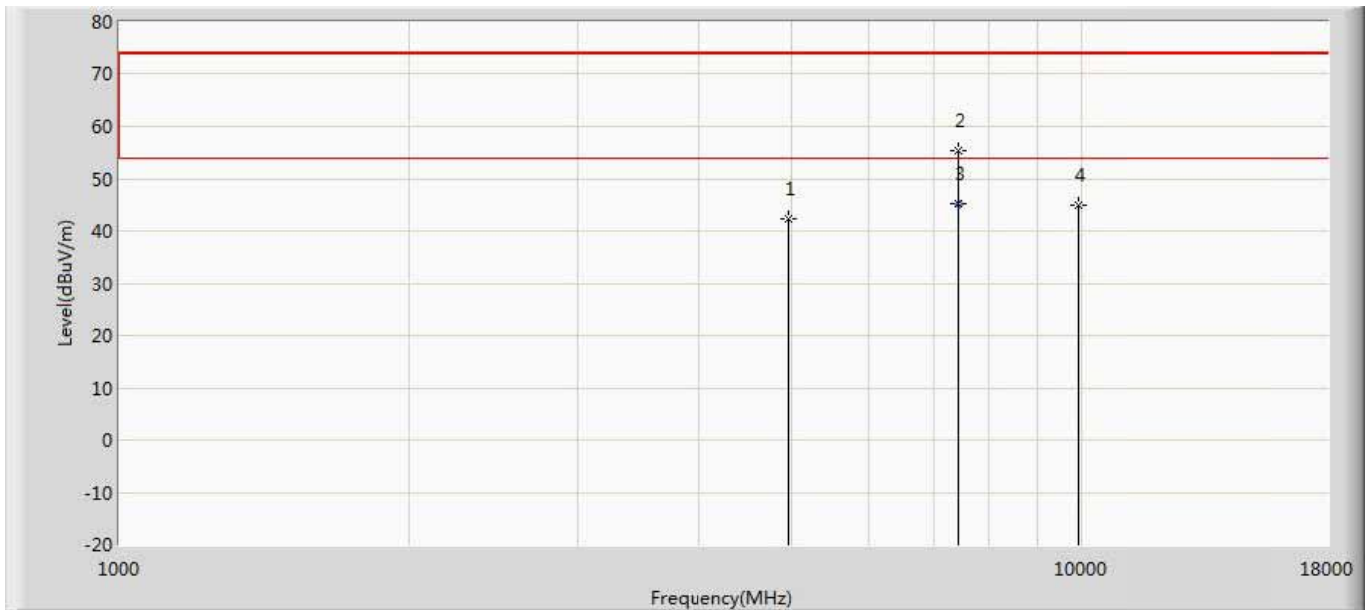

| No | Mark | Frequency (MHz) | Measure Level (dBuV/m) | Reading Level (dBuV) | Over Limit (dB) | Limit (dBuV/m) | Factor (dB) | Type |
|----|------|-----------------|------------------------|----------------------|-----------------|----------------|-------------|------|
| 1  |      | 4960.000        | 42.229                 | 37.309               | -31.771         | 74.000         | 4.920       | PK   |
| 2  |      | 7440.000        | 55.498                 | 47.783               | -18.502         | 74.000         | 7.715       | PK   |
| 3  | *    | 7440.000        | 45.276                 | 37.561               | -8.724          | 54.000         | 7.715       | AV   |
| 4  |      | 9920.000        | 44.921                 | 34.974               | -29.079         | 74.000         | 9.946       | PK   |

|  |                          |
|--|--------------------------|
| Engineer: Tongben                          |                          |
| Site: AC5                                  | Time: 2019/08/17 - 17:01 |
| Limit: FCC_Part15.209_RE(3m)               | Margin: 0                |
| Probe: Horn_3117_00167055(1-18GHz)         | Polarity: Vertical       |
| EUT: LED lamp                              | Power: AC 120V/60Hz      |
| Note: Mode 1:Transmit at 2480MHz by Zigbee |                          |

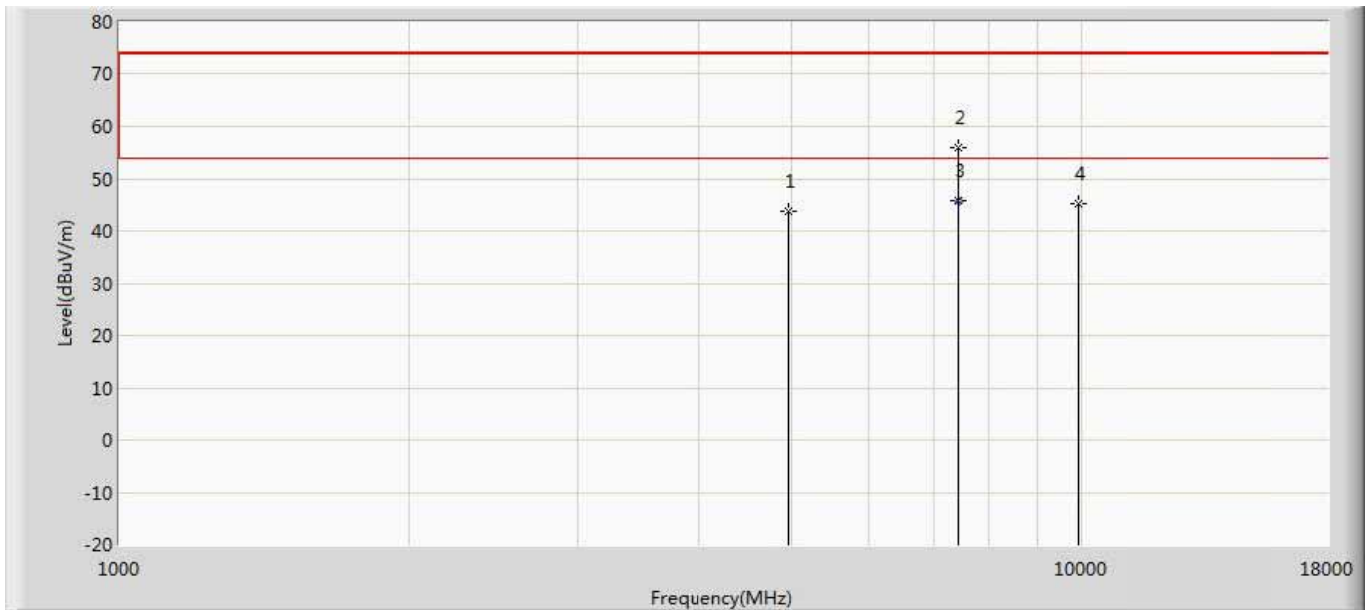

| No | Mark | Frequency (MHz) | Measure Level (dBuV/m) | Reading Level (dBuV) | Over Limit (dB) | Limit (dBuV/m) | Factor (dB) | Type |
|----|------|-----------------|------------------------|----------------------|-----------------|----------------|-------------|------|
| 1  |      | 4960.000        | 43.904                 | 38.984               | -30.096         | 74.000         | 4.920       | PK   |
| 2  |      | 7440.000        | 55.954                 | 48.239               | -18.046         | 74.000         | 7.715       | PK   |
| 3  | *    | 7440.000        | 45.876                 | 38.161               | -8.124          | 54.000         | 7.715       | AV   |
| 4  |      | 9920.000        | 45.342                 | 35.395               | -28.658         | 74.000         | 9.946       | PK   |



**Diodes:**

|  |                          |
|--|--------------------------|
| Engineer: Tongben                          |                          |
| Site: AC5                                  | Time: 2019/08/17 - 18:00 |
| Limit: FCC_Part15.209_RE(3m)               | Margin: 0                |
| Probe: Horn_3117_00167055(1-18GHz)         | Polarity: Horizontal     |
| EUT: LED lamp                              | Power: AC 120V/60Hz      |
| Note: Mode 1:Transmit at 2405MHz by Zigbee |                          |

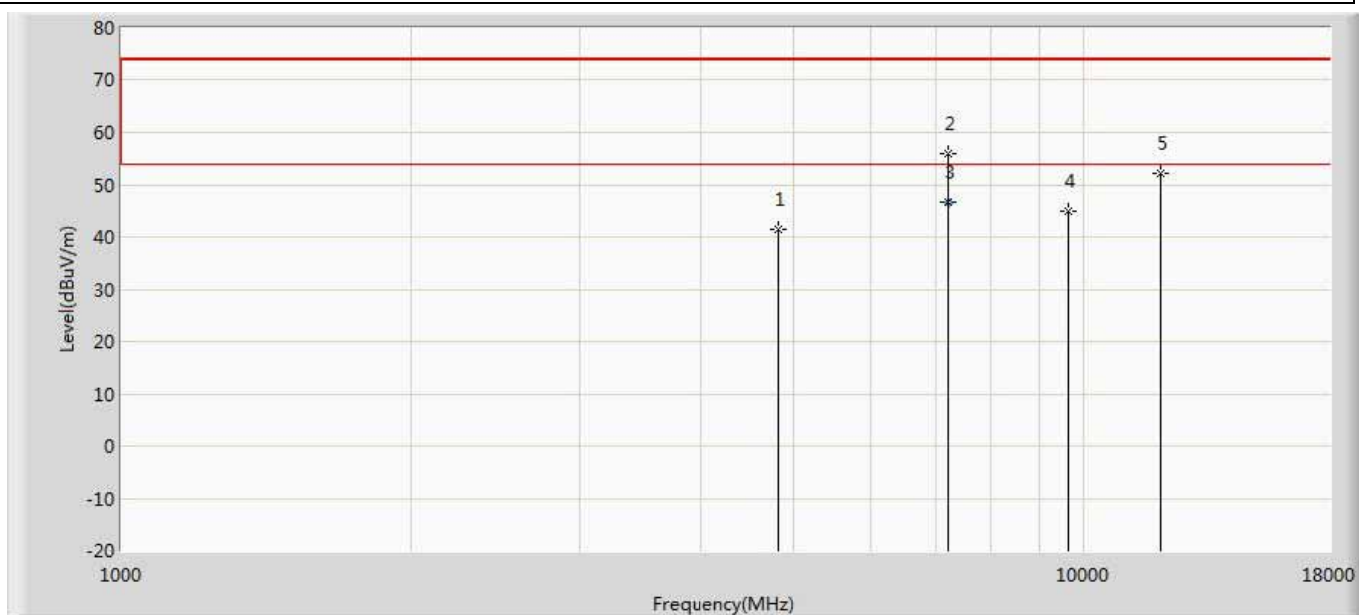

| No | Mark | Frequency (MHz) | Measure Level (dBuV/m) | Reading Level (dBuV) | Over Limit (dB) | Limit (dBuV/m) | Factor (dB) | Type |
|----|------|-----------------|------------------------|----------------------|-----------------|----------------|-------------|------|
| 1  |      | 4810.000        | 41.533                 | 37.028               | -32.467         | 74.000         | 4.505       | PK   |
| 2  |      | 7215.000        | 55.908                 | 48.350               | -18.092         | 74.000         | 7.557       | PK   |
| 3  | *    | 7215.000        | 46.770                 | 39.212               | -7.230          | 54.000         | 7.557       | AV   |
| 4  |      | 9620.000        | 44.893                 | 35.653               | -29.107         | 74.000         | 9.239       | PK   |
| 5  |      | 12025.000       | 52.051                 | 37.661               | -21.949         | 74.000         | 14.390      | PK   |

|  |                          |
|--|--------------------------|
| Engineer: Tongben                          |                          |
| Site: AC5                                  | Time: 2019/08/17 - 18:00 |
| Limit: FCC_Part15.209_RE(3m)               | Margin: 0                |
| Probe: Horn_3117_00167055(1-18GHz)         | Polarity: Vertical       |
| EUT: LED lamp                              | Power: AC 120V/60Hz      |
| Note: Mode 1:Transmit at 2405MHz by Zigbee |                          |

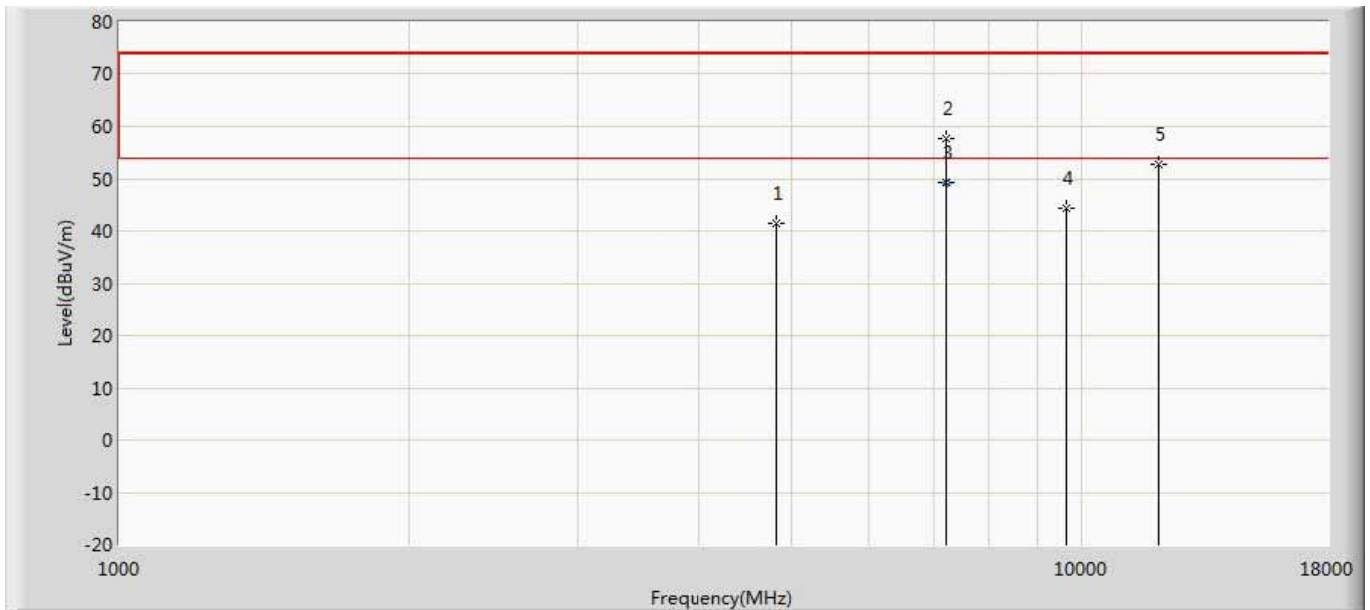

| No | Mark | Frequency (MHz) | Measure Level (dBuV/m) | Reading Level (dBuV) | Over Limit (dB) | Limit (dBuV/m) | Factor (dB) | Type |
|----|------|-----------------|------------------------|----------------------|-----------------|----------------|-------------|------|
| 1  |      | 4810.000        | 41.579                 | 37.074               | -32.421         | 74.000         | 4.505       | PK   |
| 2  |      | 7215.000        | 57.747                 | 50.189               | -16.253         | 74.000         | 7.557       | PK   |
| 3  | *    | 7215.000        | 49.166                 | 41.608               | -4.834          | 54.000         | 7.557       | AV   |
| 4  |      | 9620.000        | 44.401                 | 35.161               | -29.599         | 74.000         | 9.239       | PK   |
| 5  |      | 12025.000       | 52.628                 | 38.238               | -21.372         | 74.000         | 14.390      | PK   |

|  |                          |
|--|--------------------------|
| Engineer: Tongben                          |                          |
| Site: AC5                                  | Time: 2019/08/17 - 18:00 |
| Limit: FCC_Part15.209_RE(3m)               | Margin: 0                |
| Probe: Horn_3117_00167055(1-18GHz)         | Polarity: Horizontal     |
| EUT: LED lamp                              | Power: AC 120V/60Hz      |
| Note: Mode 1:Transmit at 2440MHz by Zigbee |                          |

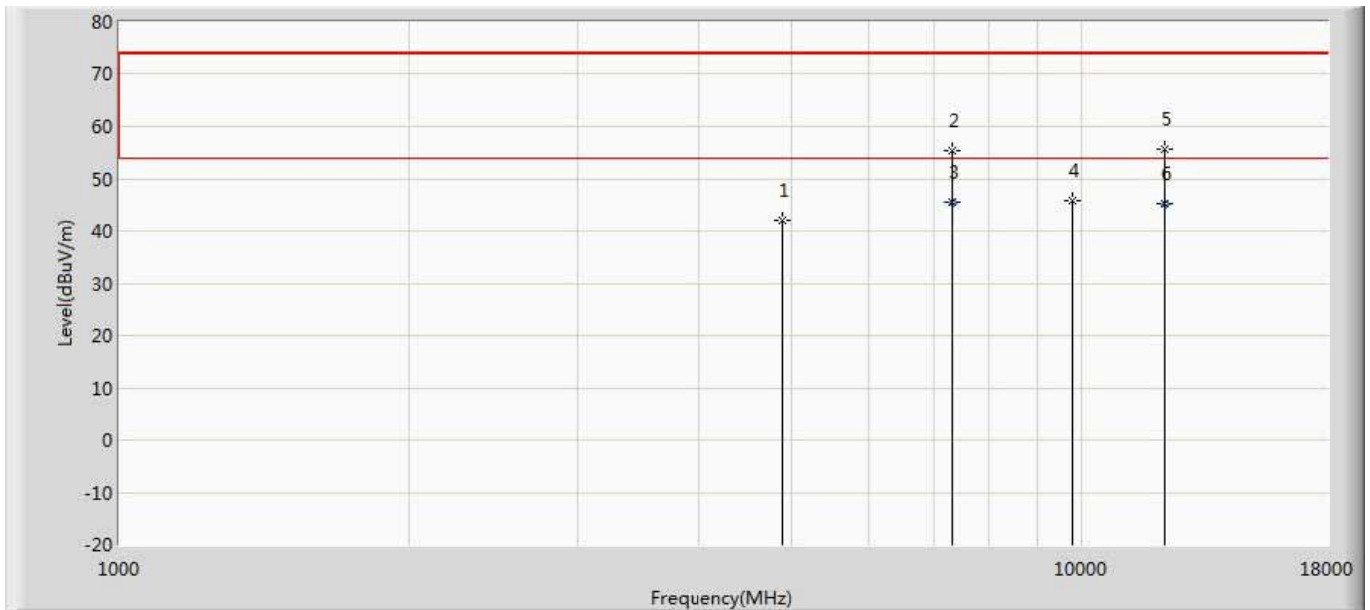

| No | Mark | Frequency (MHz) | Measure Level (dBuV/m) | Reading Level (dBuV) | Over Limit (dB) | Limit (dBuV/m) | Factor (dB) | Type |
|----|------|-----------------|------------------------|----------------------|-----------------|----------------|-------------|------|
| 1  |      | 4880.000        | 41.992                 | 37.206               | -32.008         | 74.000         | 4.786       | PK   |
| 2  |      | 7320.000        | 55.248                 | 47.586               | -18.752         | 74.000         | 7.663       | PK   |
| 3  | *    | 7320.000        | 45.397                 | 37.735               | -8.603          | 54.000         | 7.663       | AV   |
| 4  |      | 9760.000        | 45.701                 | 35.841               | -28.299         | 74.000         | 9.860       | PK   |
| 5  |      | 12200.000       | 55.752                 | 40.400               | -18.248         | 74.000         | 15.351      | PK   |
| 6  |      | 12200.000       | 45.153                 | 29.801               | -8.847          | 54.000         | 15.351      | AV   |

|  |                          |
|--|--------------------------|
| Engineer: Tongben                          |                          |
| Site: AC5                                  | Time: 2019/08/17 - 18:00 |
| Limit: FCC_Part15.209_RE(3m)               | Margin: 0                |
| Probe: Horn_3117_00167055(1-18GHz)         | Polarity: Vertical       |
| EUT: LED lamp                              | Power: AC 120V/60Hz      |
| Note: Mode 1:Transmit at 2440MHz by Zigbee |                          |

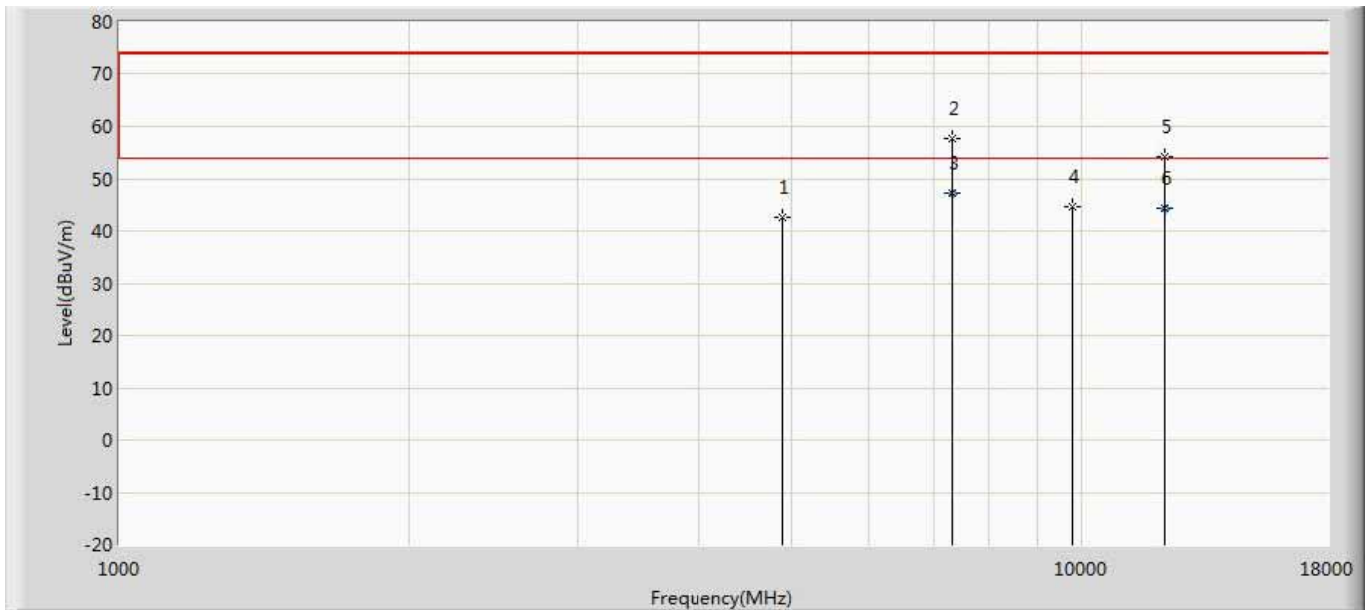

| No | Mark | Frequency (MHz) | Measure Level (dBuV/m) | Reading Level (dBuV) | Over Limit (dB) | Limit (dBuV/m) | Factor (dB) | Type |
|----|------|-----------------|------------------------|----------------------|-----------------|----------------|-------------|------|
| 1  |      | 4880.000        | 42.726                 | 37.940               | -31.274         | 74.000         | 4.786       | PK   |
| 2  |      | 7320.000        | 57.625                 | 49.963               | -16.375         | 74.000         | 7.663       | PK   |
| 3  | *    | 7320.000        | 47.356                 | 39.694               | -6.644          | 54.000         | 7.663       | AV   |
| 4  |      | 9760.000        | 44.583                 | 34.723               | -29.417         | 74.000         | 9.860       | PK   |
| 5  |      | 12200.000       | 54.233                 | 38.881               | -19.767         | 74.000         | 15.351      | PK   |
| 6  |      | 12200.000       | 44.306                 | 28.954               | -9.694          | 54.000         | 15.351      | AV   |

|  |                          |
|--|--------------------------|
| Engineer: Tongben                          |                          |
| Site: AC5                                  | Time: 2019/08/17 - 18:01 |
| Limit: FCC_Part15.209_RE(3m)               | Margin: 0                |
| Probe: Horn_3117_00167055(1-18GHz)         | Polarity: Horizontal     |
| EUT: LED lamp                              | Power: AC 120V/60Hz      |
| Note: Mode 1:Transmit at 2480MHz by Zigbee |                          |

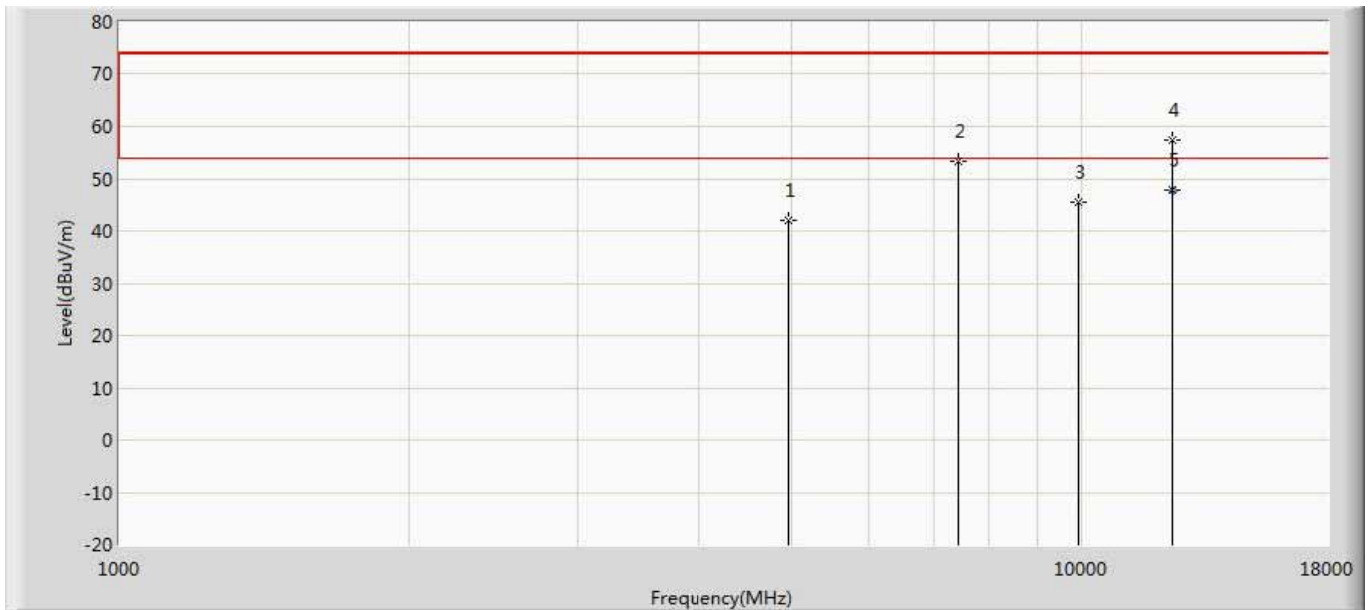

| No | Mark | Frequency (MHz) | Measure Level (dBuV/m) | Reading Level (dBuV) | Over Limit (dB) | Limit (dBuV/m) | Factor (dB) | Type |
|----|------|-----------------|------------------------|----------------------|-----------------|----------------|-------------|------|
| 1  |      | 4960.000        | 42.036                 | 37.116               | -31.964         | 74.000         | 4.920       | PK   |
| 2  |      | 7440.000        | 53.277                 | 45.562               | -20.723         | 74.000         | 7.715       | PK   |
| 3  |      | 9920.000        | 45.381                 | 35.434               | -28.619         | 74.000         | 9.946       | PK   |
| 4  |      | 12400.000       | 57.344                 | 41.345               | -16.656         | 74.000         | 15.999      | PK   |
| 5  | *    | 12400.000       | 47.757                 | 31.758               | -6.243          | 54.000         | 15.999      | AV   |

|  |                          |
|--|--------------------------|
| Engineer: Tongben                          |                          |
| Site: AC5                                  | Time: 2019/08/17 - 18:01 |
| Limit: FCC_Part15.209_RE(3m)               | Margin: 0                |
| Probe: Horn_3117_00167055(1-18GHz)         | Polarity: Vertical       |
| EUT: LED lamp                              | Power: AC 120V/60Hz      |
| Note: Mode 1:Transmit at 2480MHz by Zigbee |                          |

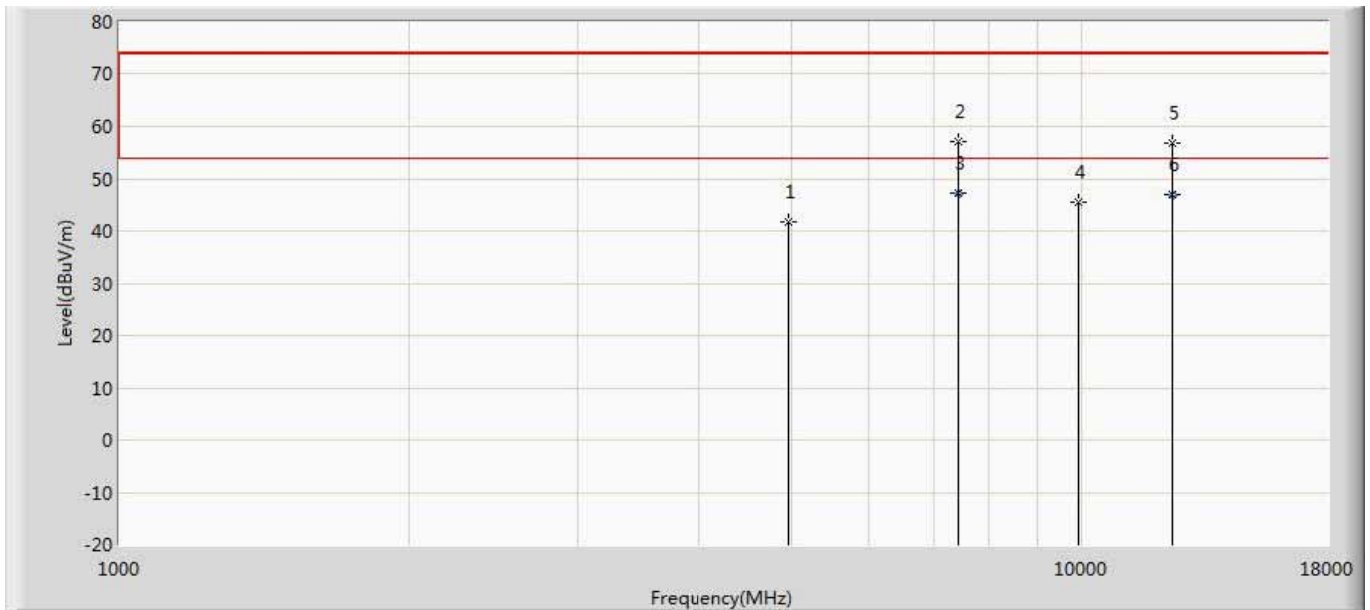

| No | Mark | Frequency (MHz) | Measure Level (dBuV/m) | Reading Level (dBuV) | Over Limit (dB) | Limit (dBuV/m) | Factor (dB) | Type |
|----|------|-----------------|------------------------|----------------------|-----------------|----------------|-------------|------|
| 1  |      | 4960.000        | 41.668                 | 36.748               | -32.332         | 74.000         | 4.920       | PK   |
| 2  |      | 7440.000        | 56.997                 | 49.282               | -17.003         | 74.000         | 7.715       | PK   |
| 3  | *    | 7440.000        | 47.112                 | 39.397               | -6.888          | 54.000         | 7.715       | AV   |
| 4  |      | 9920.000        | 45.446                 | 35.499               | -28.554         | 74.000         | 9.946       | PK   |
| 5  |      | 12400.000       | 56.824                 | 40.825               | -17.176         | 74.000         | 15.999      | PK   |
| 6  |      | 12400.000       | 46.904                 | 30.905               | -7.096          | 54.000         | 15.999      | AV   |

Note: 1. Measure Level = Reading Level + Factor.

Note: 2. The test frequency range, 9kHz~30MHz, 18GHz~25GHz, both of the worst case are at least 20dB below the limits, therefore no data appear in the report.

Note: 3. This limit applies for using average detector, if the test result on peak is lower than average limit, then average measurement needn't be performed.

Note: 4. The RBW set up, see Clause 6.6.

**The worst case of Radiated Emission below 1GHz:**

|                                     |                          |
|-------------------------------------|--------------------------|
| Engineer: Simon                     |                          |
| Site: AC3                           | Time: 2019/08/05 - 10:24 |
| Limit: FCC_Part15.109_RE(3m)_ClassB | Margin: 0                |
| Probe: AC3_3m (30-1000MHz)          | Polarity: Vertical       |
| EUT: LED Lamp                       | Power: AC 120V/60Hz      |
| Note: Mode 1:Transmit by Zigbee 1   |                          |

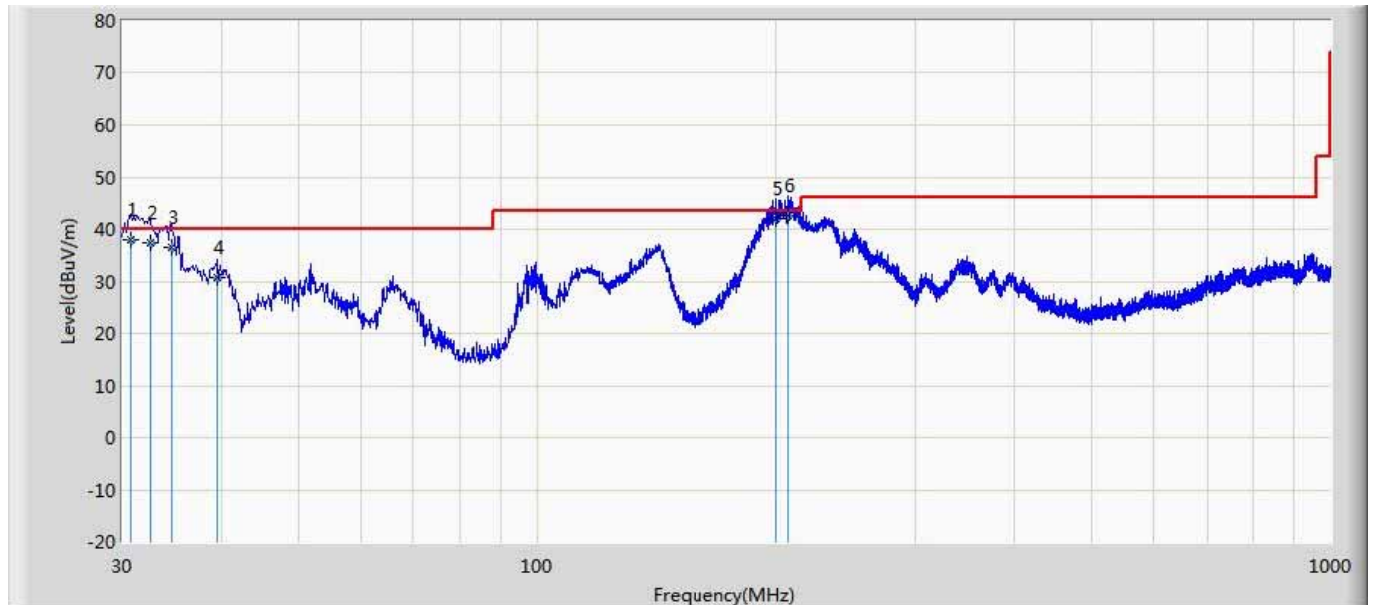

| No | Mark | Frequency (MHz) | Measure Level (dBuV/m) | Reading Level (dBuV) | Over Limit (dB) | Limit (dBuV/m) | Factor (dB) | Ant Pos (cm) | Table Pos (deg) | Type |
|----|------|-----------------|------------------------|----------------------|-----------------|----------------|-------------|--------------|-----------------|------|
| 1  |      | 30.849          | 38.062                 | 14.230               | -1.938          | 40.000         | 23.832      | 105          | 234             | QP   |
| 2  |      | 32.546          | 37.348                 | 14.068               | -2.652          | 40.000         | 23.280      | 100          | 148             | QP   |
| 3  |      | 34.607          | 36.491                 | 13.869               | -3.509          | 40.000         | 22.622      | 102          | 304             | QP   |
| 4  |      | 39.579          | 30.635                 | 11.267               | -9.365          | 40.000         | 19.368      | 108          | 56              | QP   |
| 5  |      | 200.235         | 42.105                 | 19.617               | -1.395          | 43.500         | 22.488      | 115          | 42              | QP   |
| 6  | *    | 207.389         | 42.568                 | 19.342               | -0.932          | 43.500         | 23.226      | 100          | 226             | QP   |

**Note:**

1. All Readings below 1GHz are Quasi-Peak, above are performed with peak and/or average measurements as necessary.
2. " \* ", means this data is the worst emission level.
3. Measurement Level = Reading Level + Factor(Probe+Cable-Amp).

|                                     |                          |
|-------------------------------------|--------------------------|
| Engineer: Simon                     |                          |
| Site: AC3                           | Time: 2019/08/20 - 21:47 |
| Limit: FCC_Part15.109_RE(3m)_ClassB | Margin: 0                |
| Probe: AC3_3m (30-1000MHz)          | Polarity: Vertical       |
| EUT: LED Lamp                       | Power: AC 120V/60Hz      |
| Note: Mode 1:Transmit by Zigbee 1   |                          |

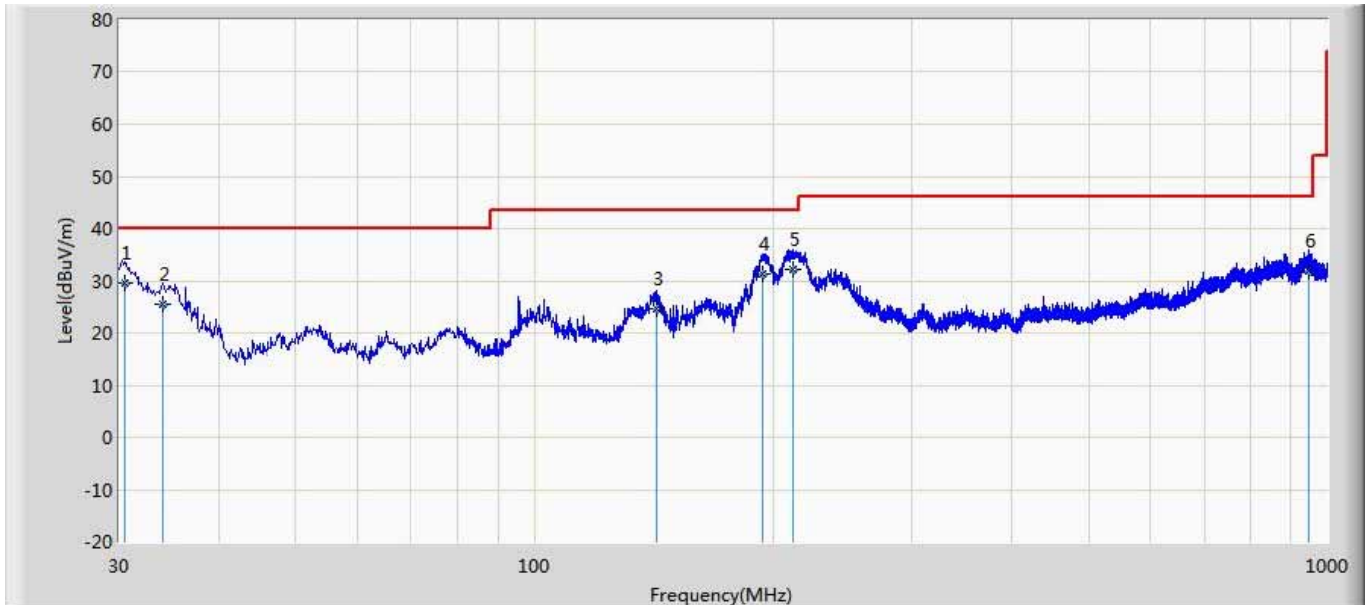

| No | Mark | Frequency (MHz) | Measure Level (dBuV/m) | Reading Level (dBuV) | Over Limit (dB) | Limit (dBuV/m) | Factor (dB) | Ant Pos (cm) | Table Pos (deg) | Type |
|----|------|-----------------|------------------------|----------------------|-----------------|----------------|-------------|--------------|-----------------|------|
| 1  | *    | 30.485          | 29.626                 | 5.677                | -10.374         | 40.000         | 23.949      | 100          | 45              | QP   |
| 2  |      | 34.001          | 25.598                 | 2.783                | -14.402         | 40.000         | 22.815      | 108          | 317             | QP   |
| 3  |      | 143.126         | 24.777                 | 5.637                | -18.723         | 43.500         | 19.139      | 100          | 27              | QP   |
| 4  |      | 194.173         | 31.276                 | 9.776                | -12.224         | 43.500         | 21.500      | 104          | 57              | QP   |
| 5  |      | 211.996         | 32.156                 | 8.971                | -11.344         | 43.500         | 23.185      | 100          | 327             | QP   |
| 6  |      | 947.499         | 31.840                 | -3.017               | -14.160         | 46.000         | 34.858      | 114          | 264             | QP   |

**Note:**

1. All Readings below 1GHz are Quasi-Peak, above are performed with peak and/or average measurements as necessary.
2. " \* ", means this data is the worst emission level.
3. Measurement Level = Reading Level + Factor(Probe+Cable-Amp).



|                                     |                          |
|-------------------------------------|--------------------------|
| Engineer: Simon                     |                          |
| Site: AC3                           | Time: 2019/08/20 - 21:49 |
| Limit: FCC_Part15.109_RE(3m)_ClassB | Margin: 0                |
| Probe: AC3_3m (30-1000MHz)          | Polarity: Horizontal     |
| EUT: LED Lamp                       | Power: AC 120V/60Hz      |
| Note: Mode 1:Transmit by Zigbee 1   |                          |

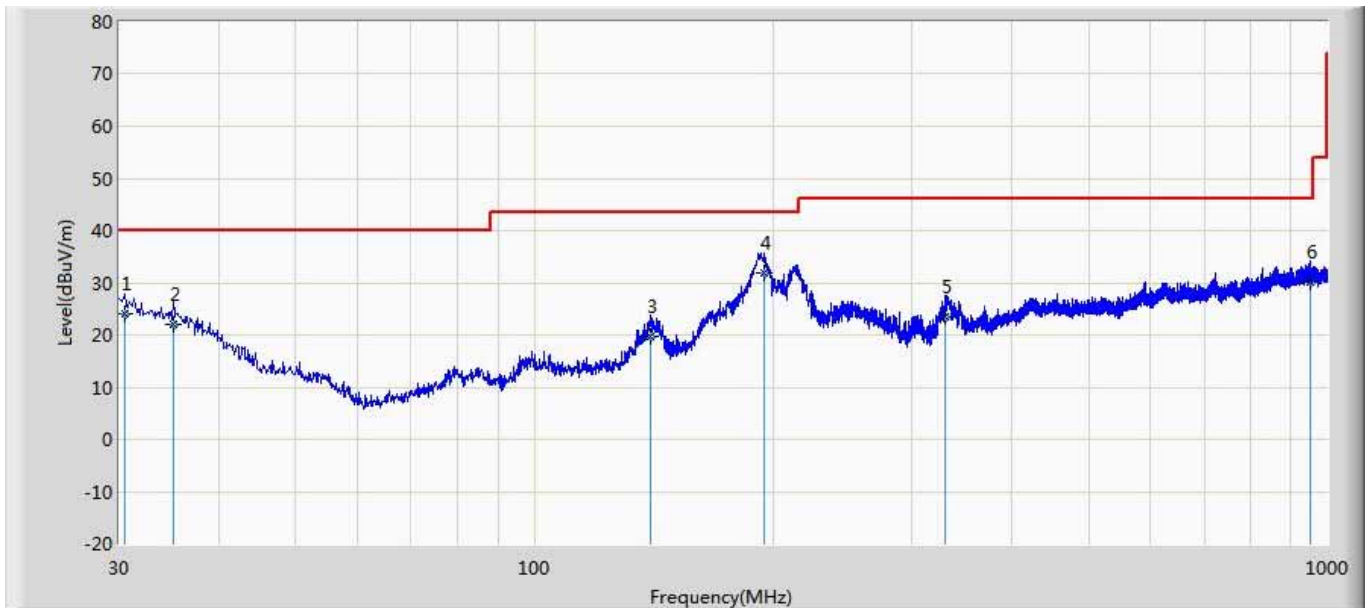

| No | Mark | Frequency (MHz) | Measure Level (dBuV/m) | Reading Level (dBuV) | Over Limit (dB) | Limit (dBuV/m) | Factor (dB) | Ant Pos (cm) | Table Pos (deg) | Type |
|----|------|-----------------|------------------------|----------------------|-----------------|----------------|-------------|--------------|-----------------|------|
| 1  |      | 30.485          | 23.995                 | -3.692               | -16.005         | 40.000         | 27.687      | 106          | 13              | QP   |
| 2  |      | 35.092          | 22.142                 | -3.447               | -17.858         | 40.000         | 25.589      | 107          | 59              | QP   |
| 3  |      | 140.459         | 19.832                 | 2.163                | -23.668         | 43.500         | 17.669      | 100          | 337             | QP   |
| 4  | *    | 195.021         | 31.885                 | 14.352               | -11.615         | 43.500         | 17.533      | 109          | 67              | QP   |
| 5  |      | 330.336         | 23.587                 | 0.963                | -22.413         | 46.000         | 22.624      | 125          | 61              | QP   |
| 6  |      | 954.289         | 30.041                 | -2.743               | -15.959         | 46.000         | 32.783      | 116          | 83              | QP   |

**Note:**

1. All Readings below 1GHz are Quasi-Peak, above are performed with peak and/or average measurements as necessary.
2. " \* ", means this data is the worst emission level.
3. Measurement Level = Reading Level + Factor(Probe+Cable-Amp).

|                                     |                          |
|-------------------------------------|--------------------------|
| Engineer: Simon                     |                          |
| Site: AC3                           | Time: 2019/08/20 - 22:14 |
| Limit: FCC_Part15.109_RE(3m)_ClassB | Margin: 0                |
| Probe: AC3_3m (30-1000MHz)          | Polarity: Vertical       |
| EUT: LED Lamp                       | Power: AC 120V/60Hz      |
| Note: Mode 1:Transmit by Zigbee 2   |                          |

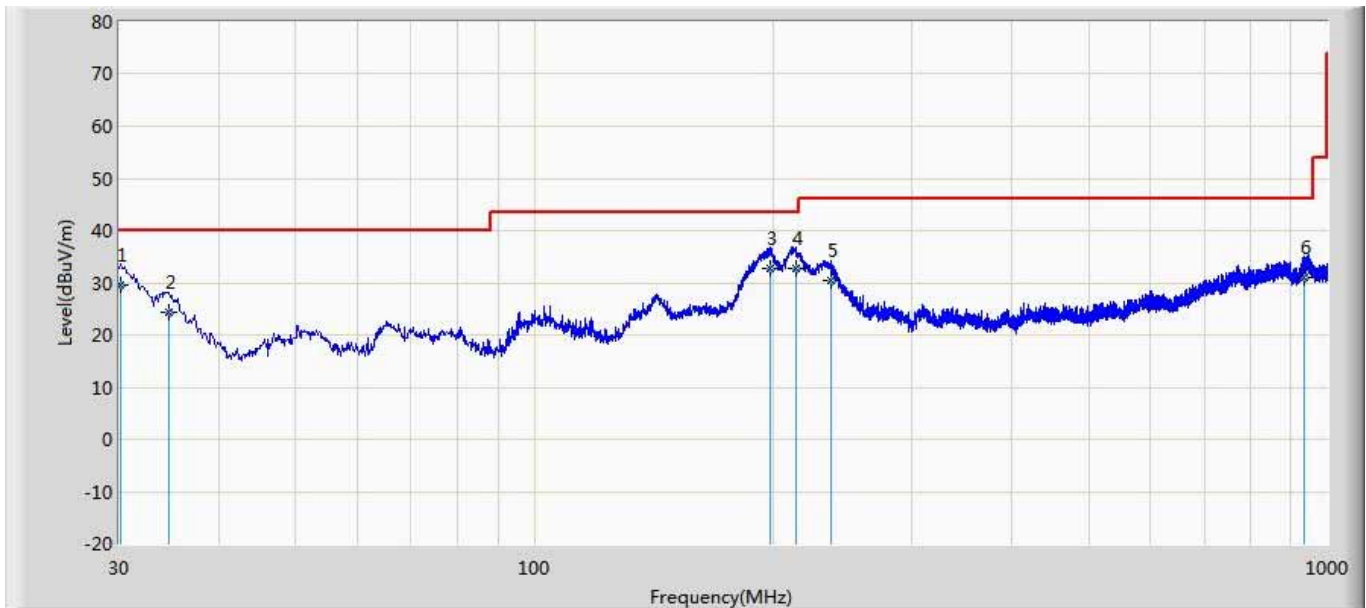

| No | Mark | Frequency (MHz) | Measure Level (dBuV/m) | Reading Level (dBuV) | Over Limit (dB) | Limit (dBuV/m) | Factor (dB) | Ant Pos (cm) | Table Pos (deg) | Type |
|----|------|-----------------|------------------------|----------------------|-----------------|----------------|-------------|--------------|-----------------|------|
| 1  | *    | 30.121          | 29.629                 | 5.563                | -10.371         | 40.000         | 24.066      | 104          | 29              | QP   |
| 2  |      | 34.729          | 24.220                 | 1.637                | -15.780         | 40.000         | 22.583      | 117          | 81              | QP   |
| 3  |      | 198.538         | 32.665                 | 10.459               | -10.835         | 43.500         | 22.206      | 100          | 237             | QP   |
| 4  |      | 213.330         | 32.690                 | 9.638                | -10.810         | 43.500         | 23.052      | 101          | 49              | QP   |
| 5  |      | 236.004         | 30.421                 | 7.559                | -15.579         | 46.000         | 22.862      | 137          | 22              | QP   |
| 6  |      | 934.646         | 31.043                 | -3.143               | -14.957         | 46.000         | 34.185      | 105          | 312             | QP   |

**Note:**

1. All Readings below 1GHz are Quasi-Peak, above are performed with peak and/or average measurements as necessary.
2. " \* ", means this data is the worst emission level.
3. Measurement Level = Reading Level + Factor(Probe+Cable-Amp).

|                                     |                          |
|-------------------------------------|--------------------------|
| Engineer: Simon                     |                          |
| Site: AC3                           | Time: 2019/08/20 - 22:22 |
| Limit: FCC_Part15.109_RE(3m)_ClassB | Margin: 0                |
| Probe: AC3_3m (30-1000MHz)          | Polarity: Horizontal     |
| EUT: LED Lamp                       | Power: AC 120V/60Hz      |
| Note: Mode 1:Transmit by Zigbee 2   |                          |

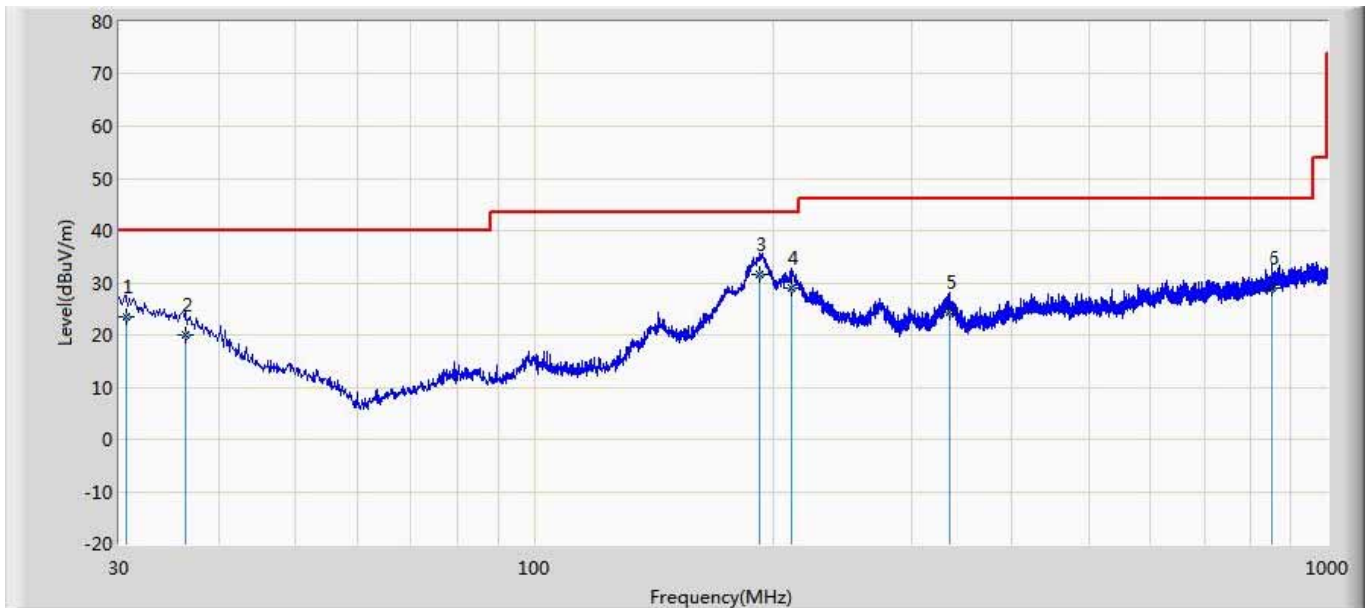

| No | Mark | Frequency (MHz) | Measure Level (dBuV/m) | Reading Level (dBuV) | Over Limit (dB) | Limit (dBuV/m) | Factor (dB) | Ant Pos (cm) | Table Pos (deg) | Type |
|----|------|-----------------|------------------------|----------------------|-----------------|----------------|-------------|--------------|-----------------|------|
| 1  |      | 30.606          | 23.588                 | -4.028               | -16.412         | 40.000         | 27.616      | 100          | 233             | QP   |
| 2  |      | 36.426          | 19.935                 | -5.317               | -20.065         | 40.000         | 25.252      | 108          | 301             | QP   |
| 3  | *    | 192.836         | 31.723                 | 14.361               | -11.777         | 43.500         | 17.362      | 112          | 27              | QP   |
| 4  |      | 211.390         | 29.044                 | 11.836               | -14.456         | 43.500         | 17.208      | 131          | 52              | QP   |
| 5  |      | 333.853         | 24.380                 | 1.367                | -21.620         | 46.000         | 23.013      | 100          | 221             | QP   |
| 6  |      | 853.045         | 29.058                 | -2.116               | -16.942         | 46.000         | 31.174      | 108          | 39              | QP   |

**Note:**

1. All Readings below 1GHz are Quasi-Peak, above are performed with peak and/or average measurements as necessary.
2. " \* ", means this data is the worst emission level.
3. Measurement Level = Reading Level + Factor(Probe+Cable-Amp).

## 5. Emissions in non-restricted frequency bands

### 5.1. Test Equipment

| Emissions in non-restricted frequency bands / TR-8 |              |          |            |            |               |
|--|--------------|----------|------------|------------|---------------|
| Instrument   | Manufacturer | Type No. | Serial No. | Cal. Date  | Cal. Due Date |
| Spectrum Analyzer                                  | Agilent      | N9010A   | MY48030494 | 2019.02.04 | 2020.02.03    |
| EXA Spectrum Analyzer                              | Keysight     | N9010A   | MY55370495 | 2019.04.09 | 2020.04.08    |
| MXA Signal Analyzer                                | Keysight     | N9020A   | MY56060147 | 2019.04.09 | 2020.04.08    |
| Temperature/Humidity Meter                         | zhichen      | ZC1-2    | TR8-TH     | 2019.04.10 | 2020.04.09    |

Note: All equipments are calibrated with traceable calibrations. Each calibration is traceable to the national or international standards.

### 5.2. Test Setup

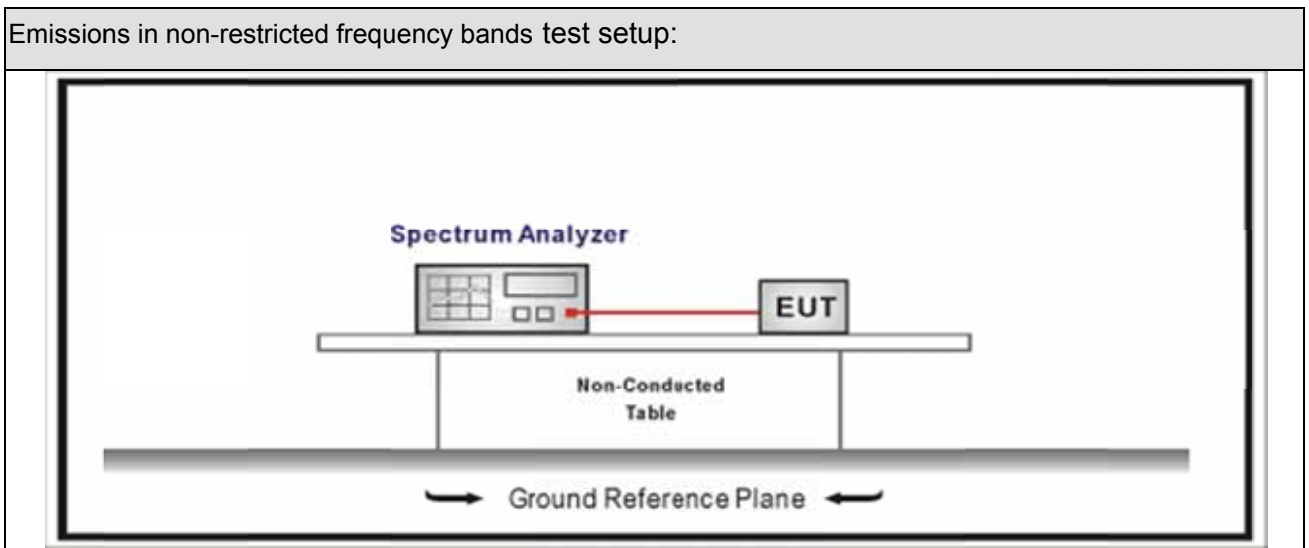



### 5.3. Limit

| Un-Restricted Band Emissions Limit   |            |
|--|------------|
| RF Output power (Detection methods)  | Limit(dB)  |
| RF Output power(Average detector)  | 30c(Note1) |
| RF Output power(PK detector)   | 20c(Note2) |
| <p>Note 1: If maximum conducted (average) output power was used to demonstrate compliance as described in 9.2, then the peak power in any 100 kHz bandwidth outside of the authorized frequency band shall be attenuated by at least 30 dB relative to the maximum in-band peak PSD level in 100 kHz (i.e., 30 dBc).</p> <p>Note 2: If the maximum peak conducted output power procedure was used, then the peak output power measured in any 100 kHz bandwidth outside of the authorized frequency band shall be attenuated by at least 20 dB relative to the maximum in-band peak PSD level in 100 kHz (i.e., 20 dBc).</p> |            |

### 5.4. Test Procedure

| Test Method                         |   |             |  |
|-------------------------------------|---|-------------|--|
|                                     | References Rule                                 | Chapter     | Description  |
| <input checked="" type="checkbox"/> | ANSI C63.10                                     | 11.11       | Emissions in non-restricted frequency bands  |
|                                     | <input checked="" type="checkbox"/> ANSI C63.10 | 11.11.2     | Reference level measurement  |
|                                     | <input checked="" type="checkbox"/> ANSI C63.10 | 11.11.3     | Emission level measurement   |
| <input type="checkbox"/>            | ANSI C63.10                                     | 11.12       | Emissions in restricted frequency bands  |
|                                     | <input type="checkbox"/> ANSI C63.10            | 11.12.1     | Radiated emission measurements   |
|                                     | <input type="checkbox"/> ANSI C63.10            | 11.12.2.7   | Radiated spurious emission test  |
| <input type="checkbox"/>            | ANSI C63.10                                     | 6.4         | Radiated emissions from unlicensed wireless devices below 30 MHz                                   |
| <input type="checkbox"/>            | ANSI C63.10                                     | 6.5         | Radiated emissions from unlicensed wireless devices in the frequency range of 30 MHz to 1000 MHz   |
| <input type="checkbox"/>            | ANSI C63.10                                     | 6.6         | Radiated emissions from unlicensed wireless devices above 1 GHz                                    |
|                                     | <input type="checkbox"/> ANSI C63.10            | 11.12.2     | Antenna-port conducted measurements  |
|                                     | <input type="checkbox"/> ANSI C63.10            | 11.12.2.3   | Quasi-peak measurement procedure   |
|                                     | <input type="checkbox"/> ANSI C63.10            | 11.12.2.4   | Peak power measurement procedure   |
|                                     | <input type="checkbox"/> ANSI C63.10            | 11.12.2.5   | Average power measurement procedures   |
|                                     | <input type="checkbox"/> ANSI C63.10            | 11.12.2.5.1 | Trace averaging with continuous EUT transmission at full power                                     |
|                                     | <input type="checkbox"/> ANSI C63.10            | 11.12.2.5.2 | Trace averaging across ON and OFF times of the EUT transmissions followed by duty cycle correction |
|                                     | <input type="checkbox"/> ANSI C63.10            | 11.12.2.5.3 | Reduced VBW averaging across ON and OFF times of the EUT transmissions with max hold               |

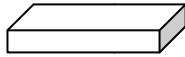
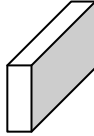
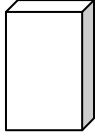
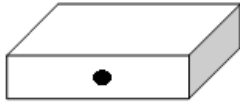
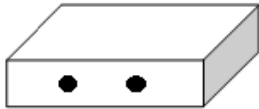
**5.5. EUT test Axis definition**

| Item                     | Emissions in non-restricted frequency bands  |  |  |  |
|--------------------------|--|--|--|--|
| Device Category          | <input type="checkbox"/>   | Fixed point-to-point   |  |  |
|                          | <input type="checkbox"/>   | Emit multiple directional beams, simultaneously or sequentially                      |  |  |
|                          | <input checked="" type="checkbox"/>  | Other cases  |  |  |
| Test mode                | Mode 1   |  |  |  |
| Test method              | <input type="checkbox"/>   | Radiated   |  |  |
|                          |  | X Axis   | Y Axis   | Z Axis   |
|                          |  |     |  |  |
|                          |  | Worst Axis <input type="checkbox"/>  | Worst Axis <input type="checkbox"/>  | Worst Axis <input type="checkbox"/>  |
|                          | <input checked="" type="checkbox"/>  | Conducted  |  |  |
|                          | <input checked="" type="checkbox"/>  | Chain 0  |  |  |
|                          |  |  |  |  |
|                          | <input type="checkbox"/>   | Chain 0  | Chain 1  |  |
|                          |  |  |  |  |
|                          |  | Worst Chain <input type="checkbox"/>   | Worst Chain <input type="checkbox"/>   |  |
| <input type="checkbox"/> | Chain 0  | Chain 1  | Chain 2  |  |
|                          |  |  |  |  |
|                          | Worst Chain <input type="checkbox"/>   | Worst Chain <input type="checkbox"/>   | Worst Chain <input type="checkbox"/>   |  |

### 5.6. Test Result

|              |              |           |                |
|--------------|--------------|-----------|----------------|
| Product Name | : LED lamp   | Power     | : AC 120V/60Hz |
| Test Mode    | : Mode 1     | Test Site | : TR-8         |
| Test Date    | : 2019.08.10 |           |                |

| Mode | Channel | Test Frequency (MHz) | In-Band PSD[a] (dBm/100kHz) | Frequency (MHz) | Out-Band PSD[b] (dBm/100kHz) | [a]-[b] (dB) | Limit (dB) | Result |
|------|---------|----------------------|-----------------------------|-----------------|------------------------------|--------------|------------|--------|
| 1    | 11      | 2405                 | 5.981                       | 2400.00         | -46.193                      | 52.174       | >20        | Pass   |
| 1    | 26      | 2480                 | 6.338                       | 2500.00         | -54.120                      | 60.458       | >20        | Pass   |

Note: The worst case of Emissions in non-restricted frequency bands as below:

Mode 1 CH11 (2405MHz)

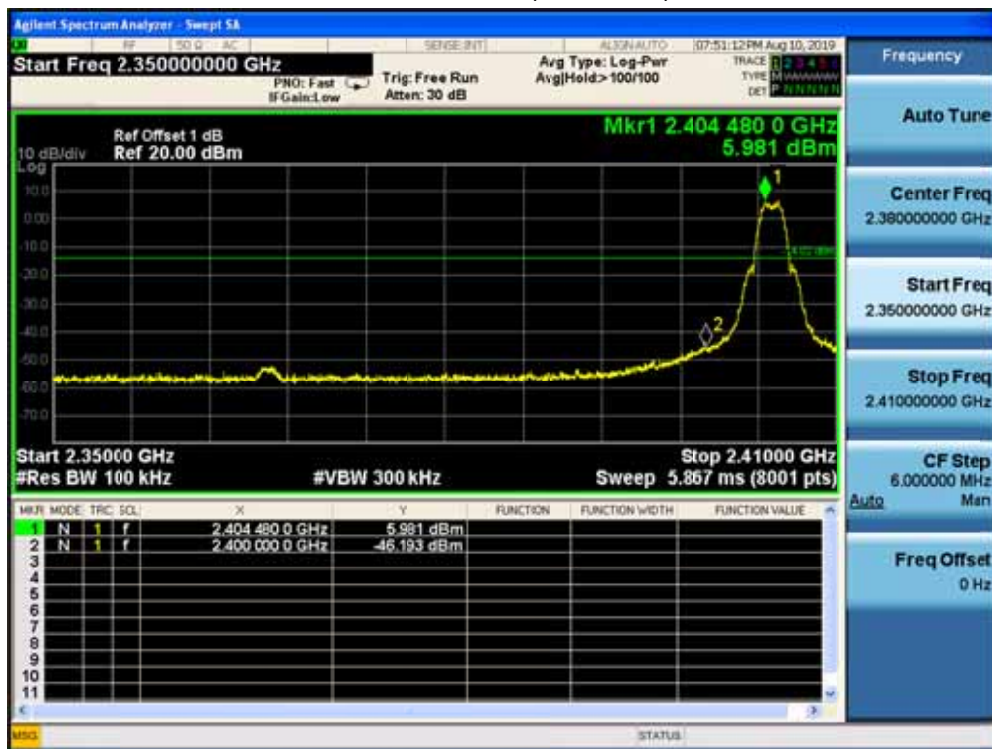



## 6. Radiated Emission Band Edge

### 6.1. Test Equipment

| Radiated Emission Band Edge / AC-5 |              |                 |            |            |               |
|------------------------------------|--------------|-----------------|------------|------------|---------------|
| Instrument                         | Manufacturer | Type No.        | Serial No. | Cal. Date  | Cal. Due Date |
| EMI Receiver                       | Agilent      | N9038A          | MY51210196 | 2019.07.16 | 2020.07.15    |
| Pre-Amplifier                      | Miteq        | NSP1800-25      | 1364185    | 2019.05.03 | 2020.05.02    |
| DRG Horn Antenna                   | ETS-Lindgren | 3117            | 00167055   | 2019.07.12 | 2020.07.11    |
| Broad-Band Horn Antenna            | Schwarzbeck  | BBHA9170        | 294        | 2018.09.18 | 2019.09.17    |
| Coaxial Cable                      | Huber+Suhner | SUCOFLEX<br>106 | AC5-C1     | 2019.02.28 | 2020.02.27    |
| Coaxial Cable                      | Huber+Suhner | SUCOFLEX<br>106 | AC5-C2     | 2019.02.28 | 2020.02.27    |
| Temperature/Humidity Meter         | Zhichen      | ZC1-2           | AC5-TH     | 2019.01.05 | 2020.01.04    |

## 6.2. Test Setup

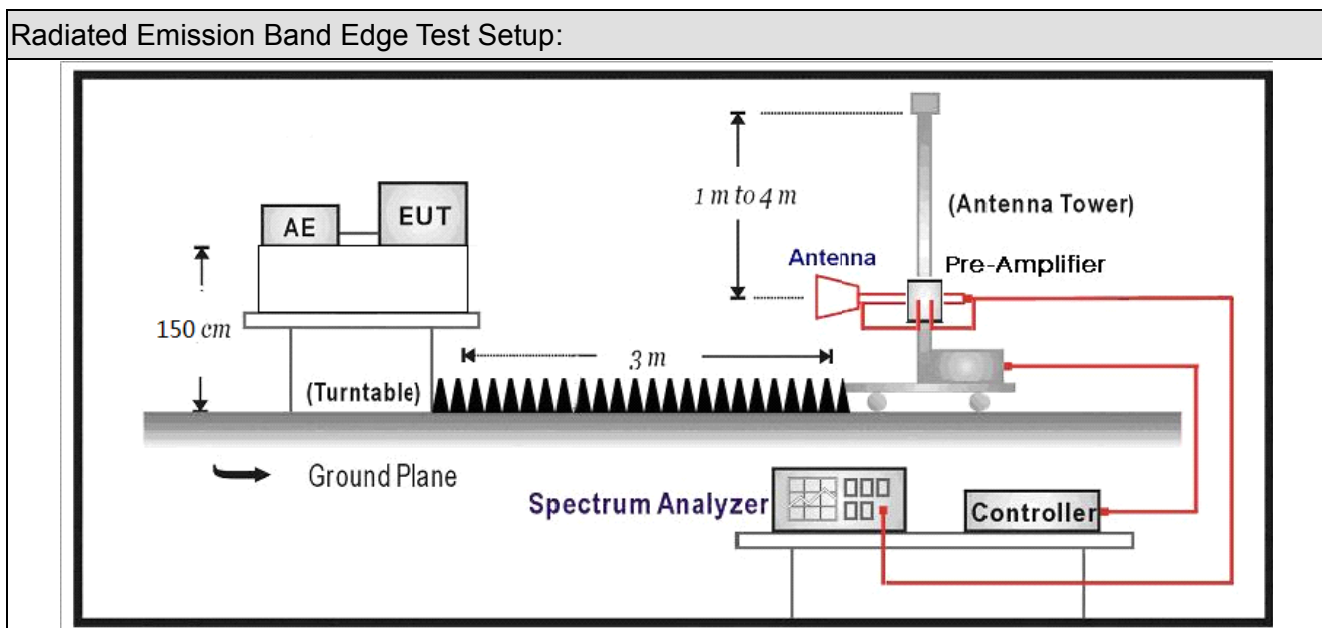

## 6.3. Limit



| Band edge Limit       |          |                      |           |              |
|-----------------------|----------|----------------------|-----------|--------------|
| Frequency bands (MHz) | Detector | Limit (dB $\mu$ V/m) | RBW (MHz) | Distance (m) |
| 2310-2390             | PK       | 74                   | 1         | 3            |
| 2483.5-2500           | AV       | 54                   | 1         | 3            |

Note: The field strength of emissions appearing within these frequency bands shall not exceed the limits.

**6.4. Test Procedure**

| Test Method                         |   |             |  |
|-------------------------------------|---|-------------|--|
|                                     | References Rule                                 | Chapter     | Description  |
| <input checked="" type="checkbox"/> | ANSI C63.10                                     | 6.10        | Band-edge testing  |
|                                     | <input checked="" type="checkbox"/> ANSI C63.10 | 6.10.5      | Restricted-band band-edge measurements   |
|                                     | <input type="checkbox"/> ANSI C63.10            | 6.10.6      | Marker-delta method  |
| <input checked="" type="checkbox"/> | ANSI C63.10                                     | 11.12       | Emissions in restricted frequency bands  |
|                                     | <input checked="" type="checkbox"/> ANSI C63.10 | 11.12.1     | Radiated emission measurements   |
|                                     | <input checked="" type="checkbox"/> ANSI C63.10 | 11.12.2.7   | Radiated spurious emission test  |
| <input type="checkbox"/>            | ANSI C63.10                                     | 6.4         | Radiated emissions from unlicensed wireless devices below 30 MHz                                   |
| <input type="checkbox"/>            | ANSI C63.10                                     | 6.5         | Radiated emissions from unlicensed wireless devices in the frequency range of 30 MHz to 1000 MHz   |
| <input checked="" type="checkbox"/> | ANSI C63.10                                     | 6.6         | Radiated emissions from unlicensed wireless devices above 1 GHz                                    |
|                                     | <input type="checkbox"/> ANSI C63.10            | 11.12.2.3   | Quasi-peak measurement procedure   |
|                                     | <input type="checkbox"/> ANSI C63.10            | 11.12.2.4   | Peak power measurement procedure   |
|                                     | <input type="checkbox"/> ANSI C63.10            | 11.12.2.5   | Average power measurement procedures   |
|                                     | <input type="checkbox"/> ANSI C63.10            | 11.12.2.5.1 | Trace averaging with continuous EUT transmission at full power                                     |
|                                     | <input type="checkbox"/> ANSI C63.10            | 11.12.2.5.2 | Trace averaging across ON and OFF times of the EUT transmissions followed by duty cycle correction |
|                                     | <input type="checkbox"/> ANSI C63.10            | 11.12.2.5.3 | Reduced VBW averaging across ON and OFF times of the EUT transmissions with max hold               |

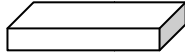
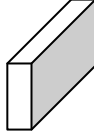
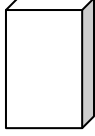
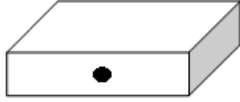
**6.5. EUT test definition**

| Item            | Radiated Emission Band Edge  |  |  |  |
|-----------------|--|--|--|--|
| Device Category | <input type="checkbox"/>   | Fixed point-to-point   |  |  |
|                 | <input type="checkbox"/>   | Emit multiple directional beams, simultaneously or sequentially                      |  |  |
|                 | <input checked="" type="checkbox"/>  | Other cases  |  |  |
| Test mode       | Mode 1   |  |  |  |
| Test method     | <input checked="" type="checkbox"/>  | Radiated   |  |  |
|                 |  | X Axis   | Y Axis   | Z Axis   |
|                 |  |     |  |  |
|                 |  | Worst Axis <input checked="" type="checkbox"/>                                       | Worst Axis <input type="checkbox"/>  | Worst Axis <input type="checkbox"/>  |
|                 | <input type="checkbox"/>   | Conducted  |  |  |
|                 | <input type="checkbox"/>   | Chain 0  |  |  |
|                 |  |  |  |  |
|                 | <input type="checkbox"/>   | Chain 0  | Chain 1  |  |
|                 |  |  |  |  |
|                 | <input type="checkbox"/>   | Chain 0  | Chain 1  | Chain 2  |
|                 |  |  |  |  |

### 6.6. Duty Cycle

| Test Mode | Tx On (ms) | Tx Off (ms) | Reduced VBW (Hz) | Tx On + Tx Off (ms) | Duty Cycle |
|-----------|------------|-------------|------------------|---------------------|------------|
| Zigbee    | N/A        | N/A         | 10               | N/A                 | 100%       |

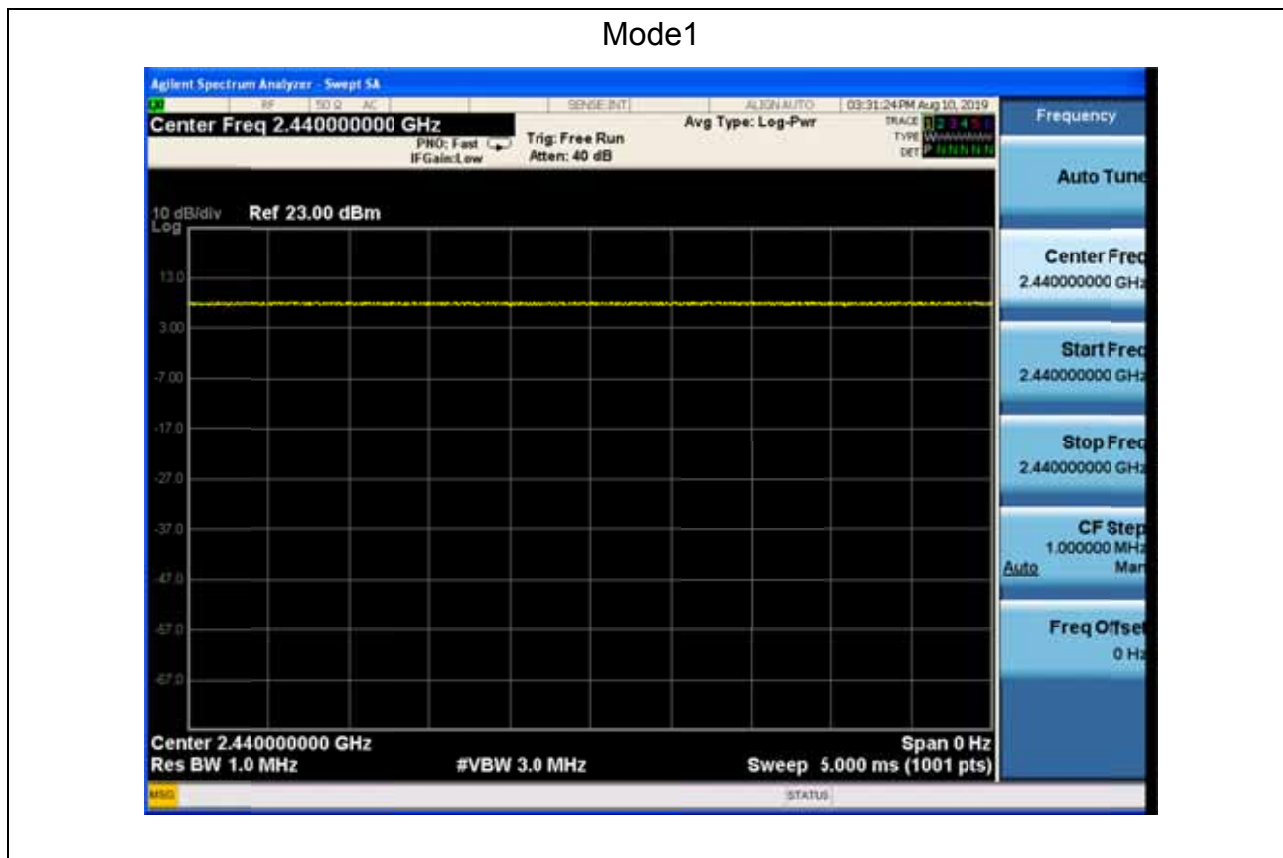

### 6.7 Test Result

**Muruta:**

|  |                          |
|--|--------------------------|
| Engineer: Tongben                          |                          |
| Site: AC5                                  | Time: 2019/08/12 - 10:04 |
| Limit: FCC_Part15.209_RE(3m)               | Margin: 0                |
| Probe: Horn_3117_00167055(1-18GHz)         | Polarity: Horizontal     |
| EUT: LED lamp                              | Power: AC 120V/60Hz      |
| Note: Mode 1:Transmit at 2405MHz by Zigbee |                          |

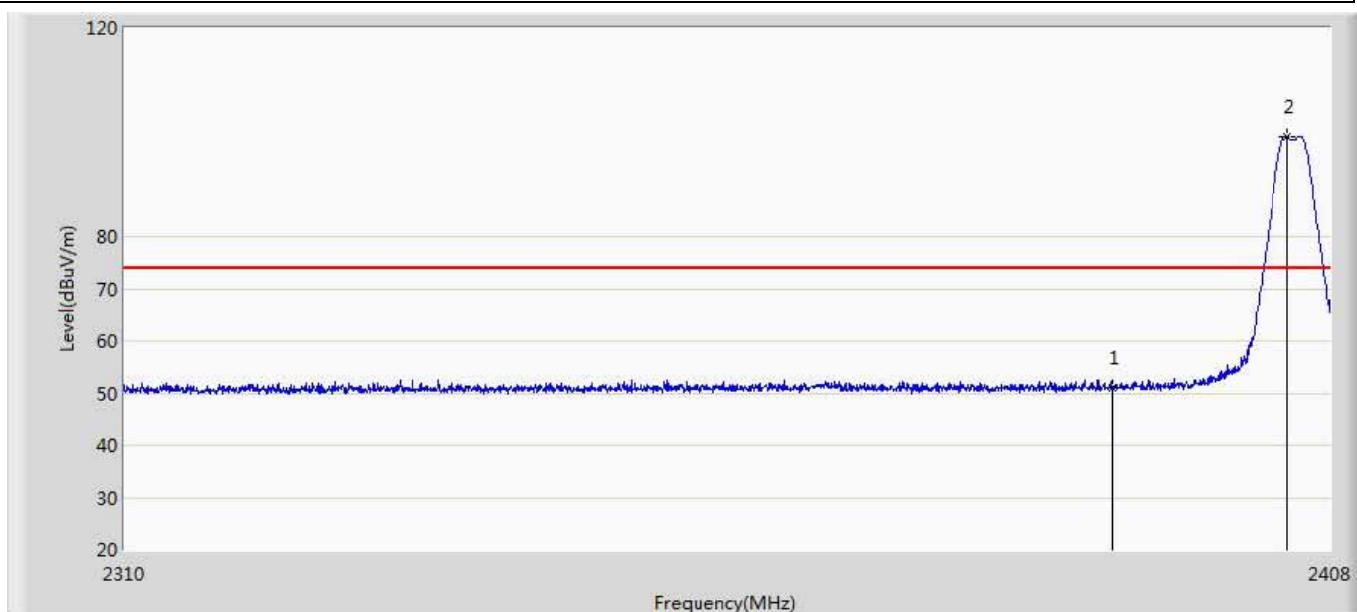

| No | Mark | Frequency (MHz) | Measure Level (dBuV/m) | Reading Level (dBuV) | Over Limit (dB) | Limit (dBuV/m) | Factor (dB) | Type |
|----|------|-----------------|------------------------|----------------------|-----------------|----------------|-------------|------|
| 1  |      | 2390.000        | 50.926                 | 15.244               | -23.074         | 74.000         | 35.682      | PK   |
| 2  | *    | 2404.521        | 99.077                 | 63.357               | 25.077          | 74.000         | 35.719      | PK   |

|  |                          |
|--|--------------------------|
| Engineer: Tongben                          |                          |
| Site: AC5                                  | Time: 2019/08/17 - 16:12 |
| Limit: FCC_Part15.209_RE(3m)               | Margin: 0                |
| Probe: Horn_3117_00167055(1-18GHz)         | Polarity: Vertical       |
| EUT: LED lamp                              | Power: AC 120V/60Hz      |
| Note: Mode 1:Transmit at 2405MHz by Zigbee |                          |

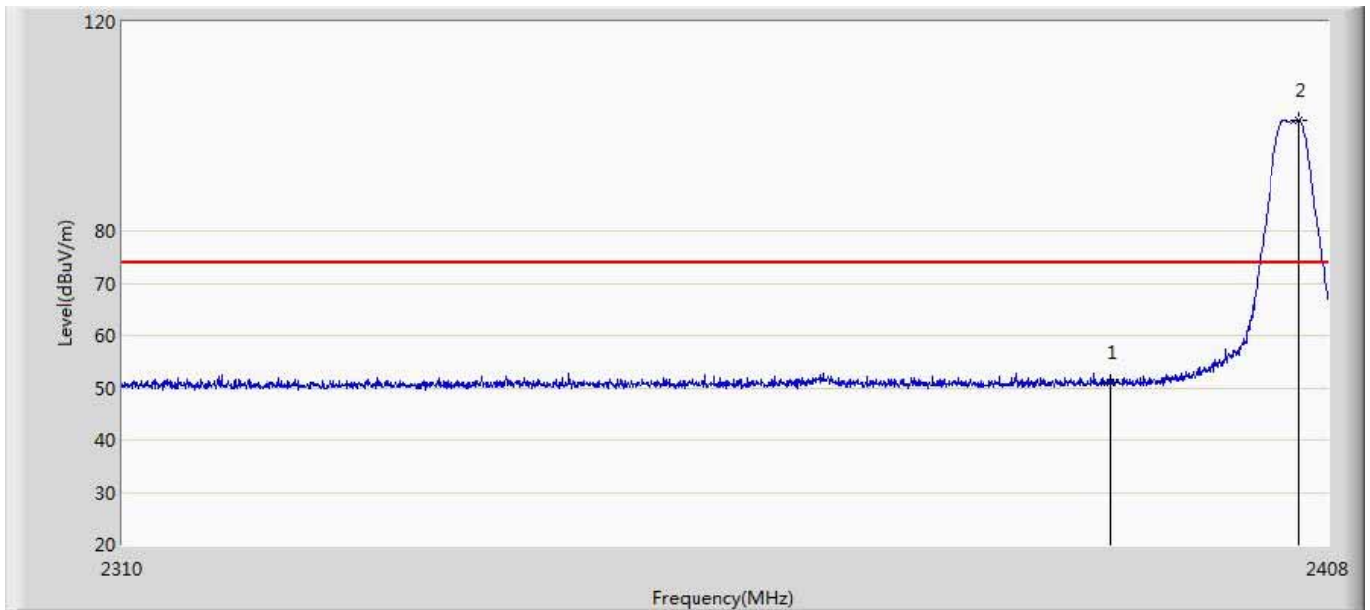

| No | Mark | Frequency (MHz) | Measure Level (dBuV/m) | Reading Level (dBuV) | Over Limit (dB) | Limit (dBuV/m) | Factor (dB) | Type |
|----|------|-----------------|------------------------|----------------------|-----------------|----------------|-------------|------|
| 1  |      | 2390.000        | 51.108                 | 15.426               | -22.892         | 74.000         | 35.682      | PK   |
| 2  | *    | 2405.599        | 101.289                | 65.567               | 27.289          | 74.000         | 35.723      | PK   |

|  |                          |
|--|--------------------------|
| Engineer: Tongben                          |                          |
| Site: AC5                                  | Time: 2019/08/17 - 16:14 |
| Limit: FCC_Part15.209_RE(3m)               | Margin: 0                |
| Probe: Horn_3117_00167055(1-18GHz)         | Polarity: Horizontal     |
| EUT: LED lamp                              | Power: AC 120V/60Hz      |
| Note: Mode 1:Transmit at 2405MHz by Zigbee |                          |

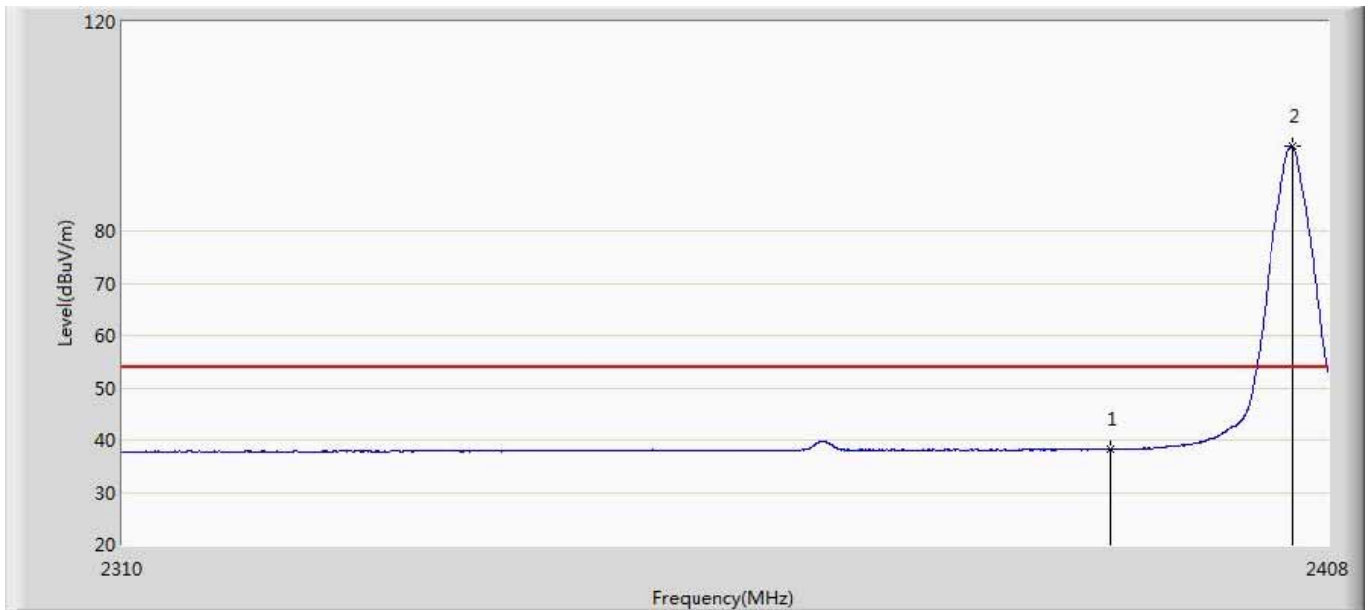

| No | Mark | Frequency (MHz) | Measure Level (dBuV/m) | Reading Level (dBuV) | Over Limit (dB) | Limit (dBuV/m) | Factor (dB) | Type |
|----|------|-----------------|------------------------|----------------------|-----------------|----------------|-------------|------|
| 1  |      | 2390.000        | 38.198                 | 2.516                | -15.802         | 54.000         | 35.682      | AV   |
| 2  | *    | 2405.109        | 96.273                 | 60.552               | 42.273          | 54.000         | 35.721      | AV   |



|  |                          |
|--|--------------------------|
| Engineer: Tongben                          |                          |
| Site: AC5                                  | Time: 2019/08/17 - 16:15 |
| Limit: FCC_Part15.209_RE(3m)               | Margin: 0                |
| Probe: Horn_3117_00167055(1-18GHz)         | Polarity: Vertical       |
| EUT: LED lamp                              | Power: AC 120V/60Hz      |
| Note: Mode 1:Transmit at 2405MHz by Zigbee |                          |

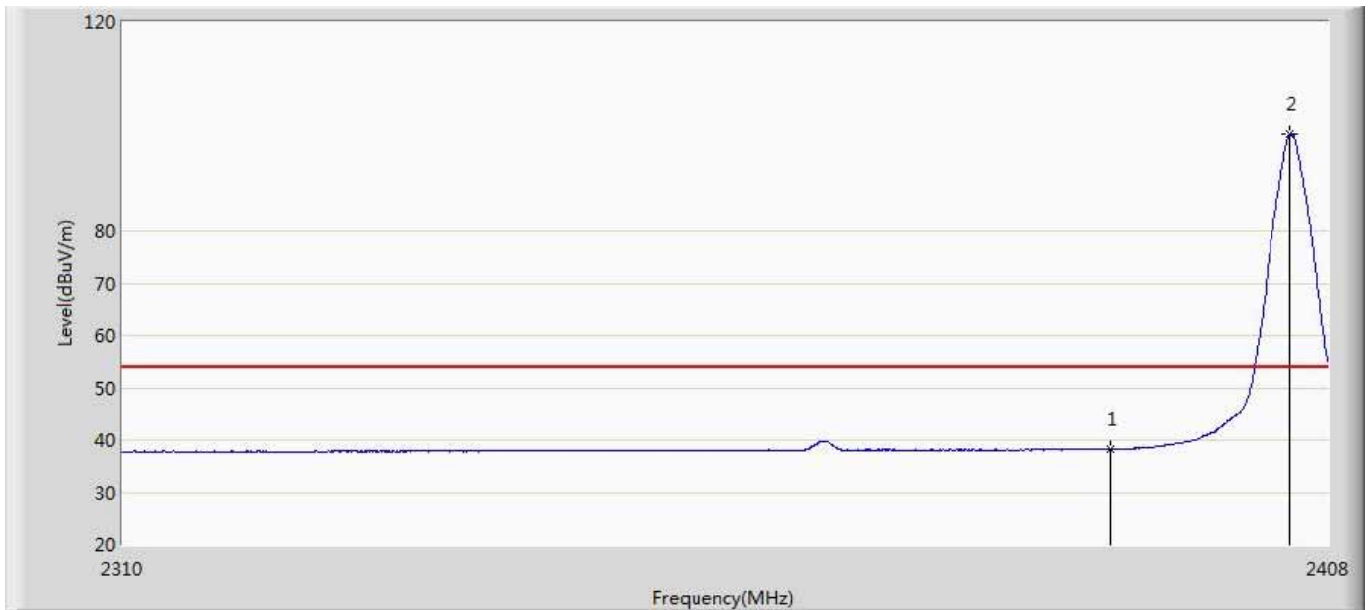

| No | Mark | Frequency (MHz) | Measure Level (dBuV/m) | Reading Level (dBuV) | Over Limit (dB) | Limit (dBuV/m) | Factor (dB) | Type |
|----|------|-----------------|------------------------|----------------------|-----------------|----------------|-------------|------|
| 1  |      | 2390.000        | 38.267                 | 2.585                | -15.733         | 54.000         | 35.682      | AV   |
| 2  | *    | 2404.913        | 98.465                 | 62.744               | 44.465          | 54.000         | 35.721      | AV   |

|  |                          |
|--|--------------------------|
| Engineer: Tongben                          |                          |
| Site: AC5                                  | Time: 2019/08/17 - 16:39 |
| Limit: FCC_Part15.209_RE(3m)               | Margin: 0                |
| Probe: Horn_3117_00167055(1-18GHz)         | Polarity: Horizontal     |
| EUT: LED lamp                              | Power: AC 120V/60Hz      |
| Note: Mode 1:Transmit at 2480MHz by Zigbee |                          |

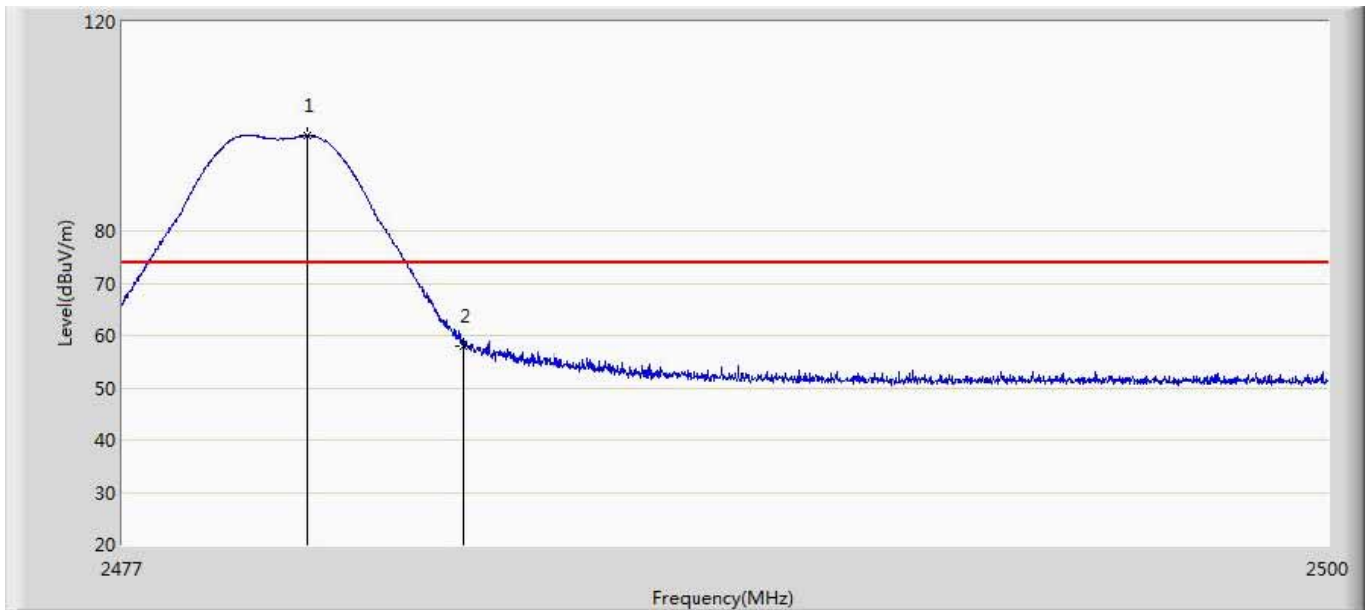

| No | Mark | Frequency (MHz) | Measure Level (dBuV/m) | Reading Level (dBuV) | Over Limit (dB) | Limit (dBuV/m) | Factor (dB) | Type |
|----|------|-----------------|------------------------|----------------------|-----------------|----------------|-------------|------|
| 1  | *    | 2480.542        | 98.188                 | 62.318               | 24.188          | 74.000         | 35.870      | PK   |
| 2  |      | 2483.500        | 58.087                 | 22.195               | -15.913         | 74.000         | 35.891      | PK   |

|  |                          |
|--|--------------------------|
| Engineer: Tongben                          |                          |
| Site: AC5                                  | Time: 2019/08/17 - 16:44 |
| Limit: FCC_Part15.209_RE(3m)               | Margin: 0                |
| Probe: Horn_3117_00167055(1-18GHz)         | Polarity: Vertical       |
| EUT: LED lamp                              | Power: AC 120V/60Hz      |
| Note: Mode 1:Transmit at 2480MHz by Zigbee |                          |

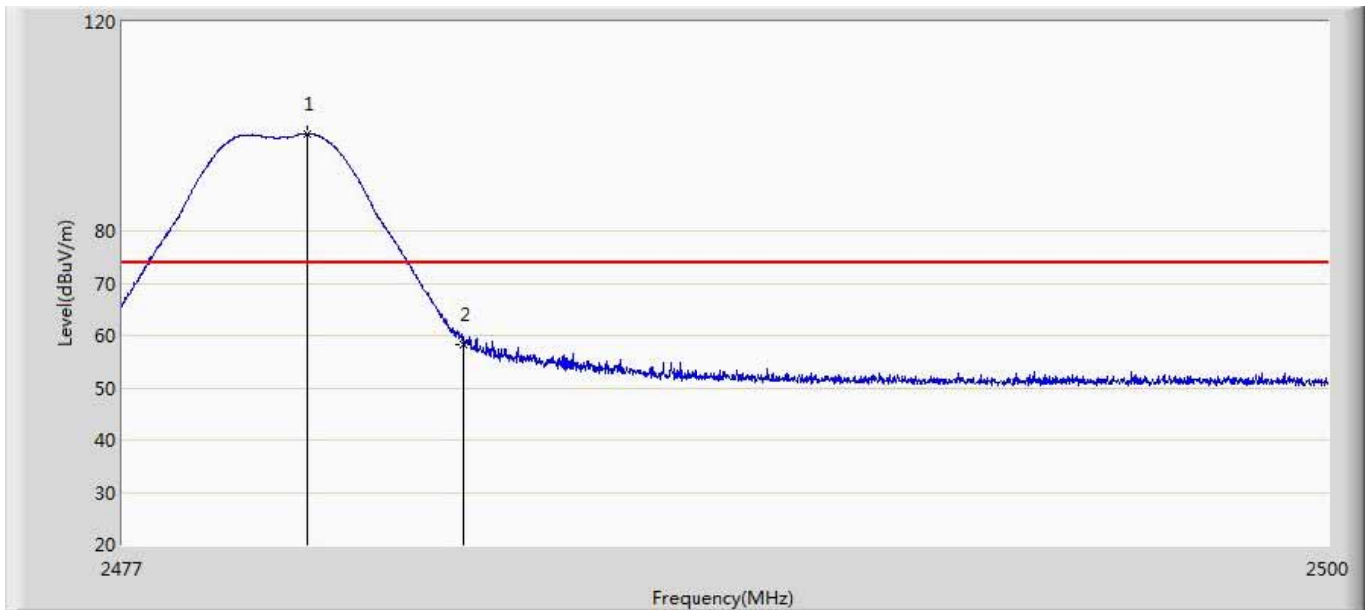

| No | Mark | Frequency (MHz) | Measure Level (dBuV/m) | Reading Level (dBuV) | Over Limit (dB) | Limit (dBuV/m) | Factor (dB) | Type |
|----|------|-----------------|------------------------|----------------------|-----------------|----------------|-------------|------|
| 1  | *    | 2480.542        | 98.512                 | 62.642               | 24.512          | 74.000         | 35.870      | PK   |
| 2  |      | 2483.500        | 58.376                 | 22.484               | -15.624         | 74.000         | 35.891      | PK   |

|  |                          |
|--|--------------------------|
| Engineer: Tongben                          |                          |
| Site: AC5                                  | Time: 2019/08/17 - 16:45 |
| Limit: FCC_Part15.209_RE(3m)               | Margin: 0                |
| Probe: Horn_3117_00167055(1-18GHz)         | Polarity: Horizontal     |
| EUT: LED lamp                              | Power: AC 120V/60Hz      |
| Note: Mode 1:Transmit at 2480MHz by Zigbee |                          |

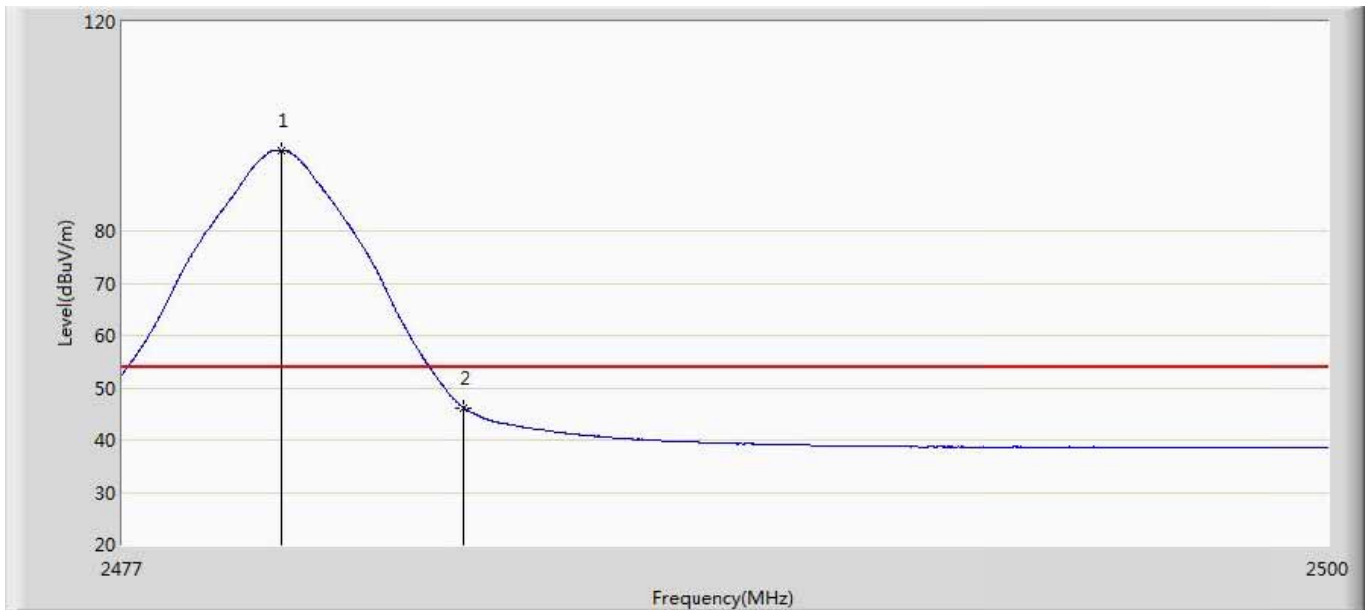

| No | Mark | Frequency (MHz) | Measure Level (dBuV/m) | Reading Level (dBuV) | Over Limit (dB) | Limit (dBuV/m) | Factor (dB) | Type |
|----|------|-----------------|------------------------|----------------------|-----------------|----------------|-------------|------|
| 1  | *    | 2480.036        | 95.433                 | 59.566               | 41.433          | 54.000         | 35.866      | AV   |
| 2  |      | 2483.500        | 46.133                 | 10.241               | -7.867          | 54.000         | 35.891      | AV   |

|  |                          |
|--|--------------------------|
| Engineer: Tongben                          |                          |
| Site: AC5                                  | Time: 2019/08/17 - 16:47 |
| Limit: FCC_Part15.209_RE(3m)               | Margin: 0                |
| Probe: Horn_3117_00167055(1-18GHz)         | Polarity: Vertical       |
| EUT: LED lamp                              | Power: AC 120V/60Hz      |
| Note: Mode 1:Transmit at 2480MHz by Zigbee |                          |

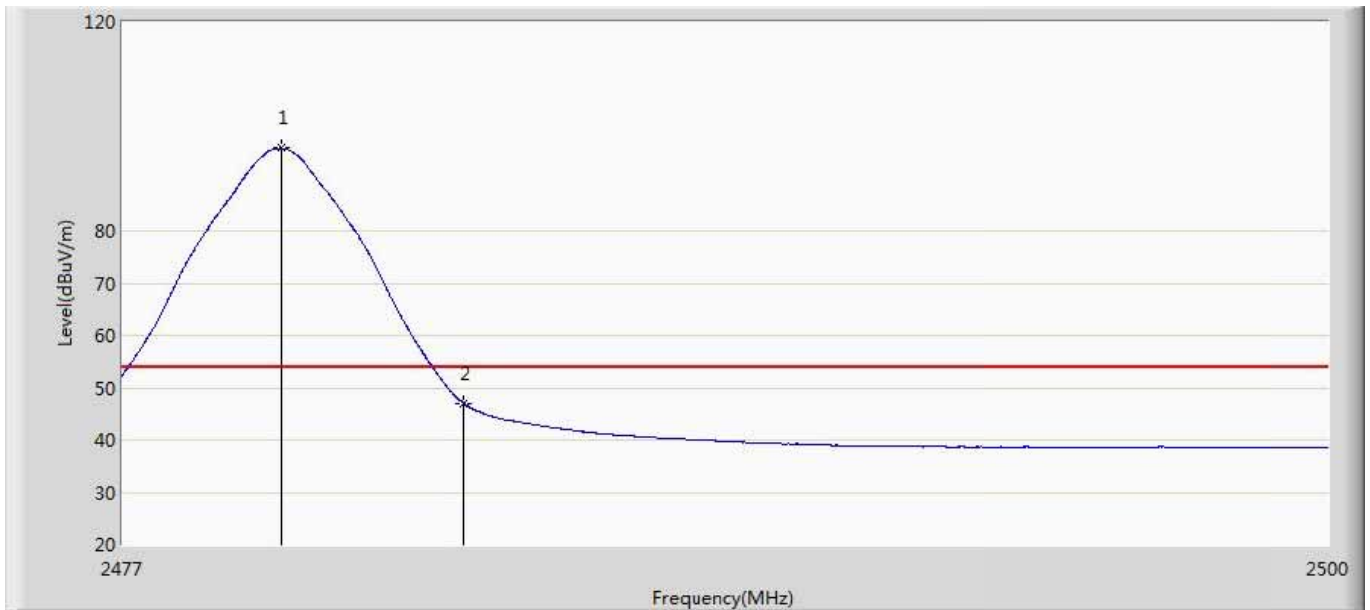

| No | Mark | Frequency (MHz) | Measure Level (dBuV/m) | Reading Level (dBuV) | Over Limit (dB) | Limit (dBuV/m) | Factor (dB) | Type |
|----|------|-----------------|------------------------|----------------------|-----------------|----------------|-------------|------|
| 1  | *    | 2480.036        | 95.800                 | 59.933               | 41.800          | 54.000         | 35.866      | AV   |
| 2  |      | 2483.500        | 47.011                 | 11.119               | -6.989          | 54.000         | 35.891      | AV   |

**Diodes:**

|  |                          |
|--|--------------------------|
| Engineer: Tongben                          |                          |
| Site: AC5                                  | Time: 2019/08/17 - 17:06 |
| Limit: FCC_Part15.209_RE(3m)               | Margin: 0                |
| Probe: Horn_3117_00167055(1-18GHz)         | Polarity: Horizontal     |
| EUT: LED lamp                              | Power: AC 120V/60Hz      |
| Note: Mode 1:Transmit at 2405MHz by Zigbee |                          |

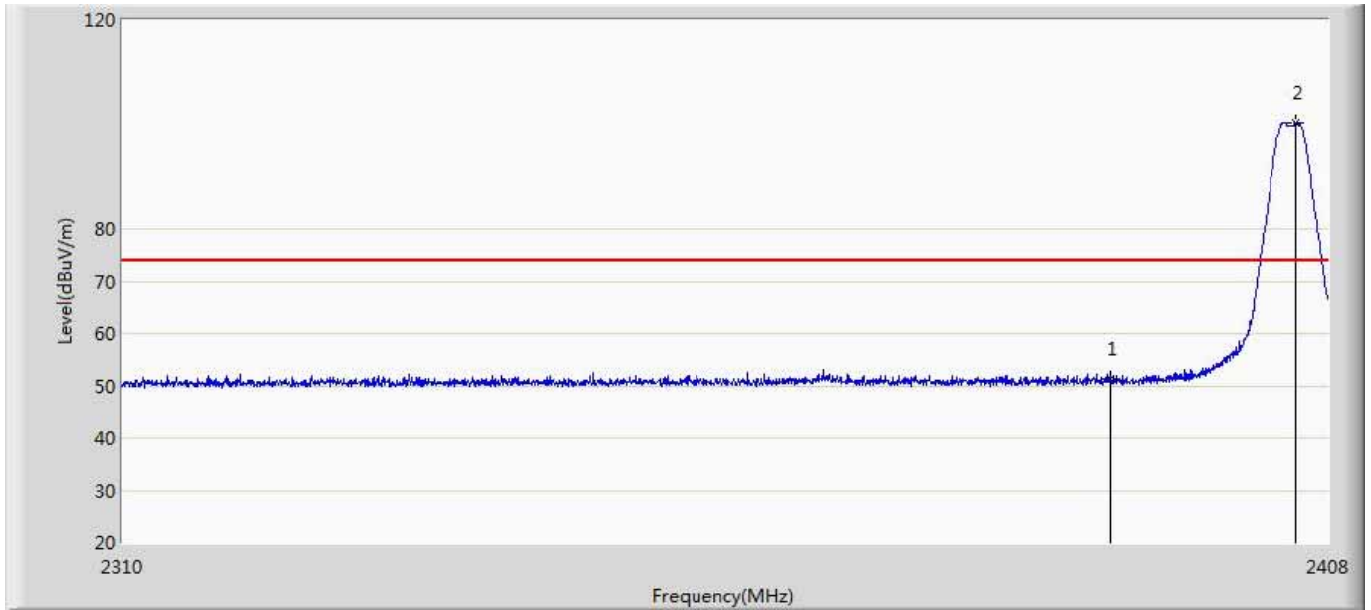

| No | Mark | Frequency (MHz) | Measure Level (dBuV/m) | Reading Level (dBuV) | Over Limit (dB) | Limit (dBuV/m) | Factor (dB) | Type |
|----|------|-----------------|------------------------|----------------------|-----------------|----------------|-------------|------|
| 1  |      | 2390.000        | 51.352                 | 15.670               | -22.648         | 74.000         | 35.682      | PK   |
| 2  | *    | 2405.403        | 100.356                | 64.634               | 26.356          | 74.000         | 35.722      | PK   |

|  |                          |
|--|--------------------------|
| Engineer: Tongben                          |                          |
| Site: AC5                                  | Time: 2019/08/17 - 17:09 |
| Limit: FCC_Part15.209_RE(3m)               | Margin: 0                |
| Probe: Horn_3117_00167055(1-18GHz)         | Polarity: Vertical       |
| EUT: LED lamp                              | Power: AC 120V/60Hz      |
| Note: Mode 1:Transmit at 2405MHz by Zigbee |                          |

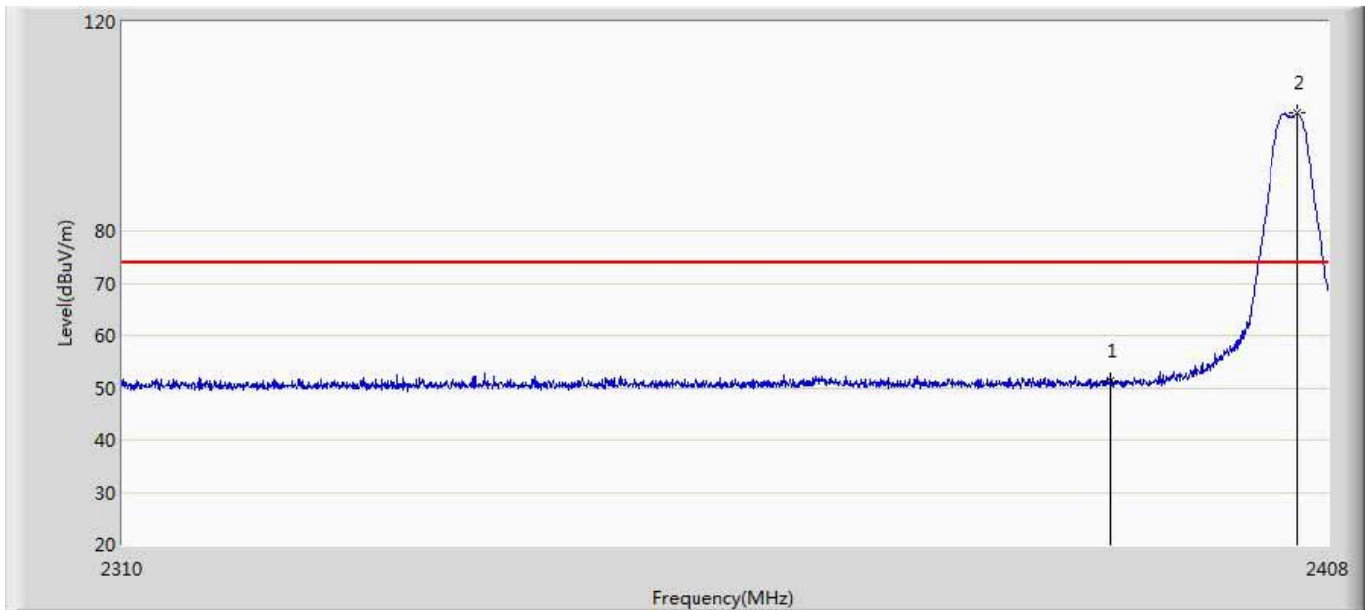

| No | Mark | Frequency (MHz) | Measure Level (dBuV/m) | Reading Level (dBuV) | Over Limit (dB) | Limit (dBuV/m) | Factor (dB) | Type |
|----|------|-----------------|------------------------|----------------------|-----------------|----------------|-------------|------|
| 1  |      | 2390.000        | 51.448                 | 15.766               | -22.552         | 74.000         | 35.682      | PK   |
| 2  | *    | 2405.550        | 102.471                | 66.749               | 28.471          | 74.000         | 35.723      | PK   |

|  |                          |
|--|--------------------------|
| Engineer: Tongben                          |                          |
| Site: AC5                                  | Time: 2019/08/17 - 17:10 |
| Limit: FCC_Part15.209_RE(3m)               | Margin: 0                |
| Probe: Horn_3117_00167055(1-18GHz)         | Polarity: Horizontal     |
| EUT: LED lamp                              | Power: AC 120V/60Hz      |
| Note: Mode 1:Transmit at 2405MHz by Zigbee |                          |

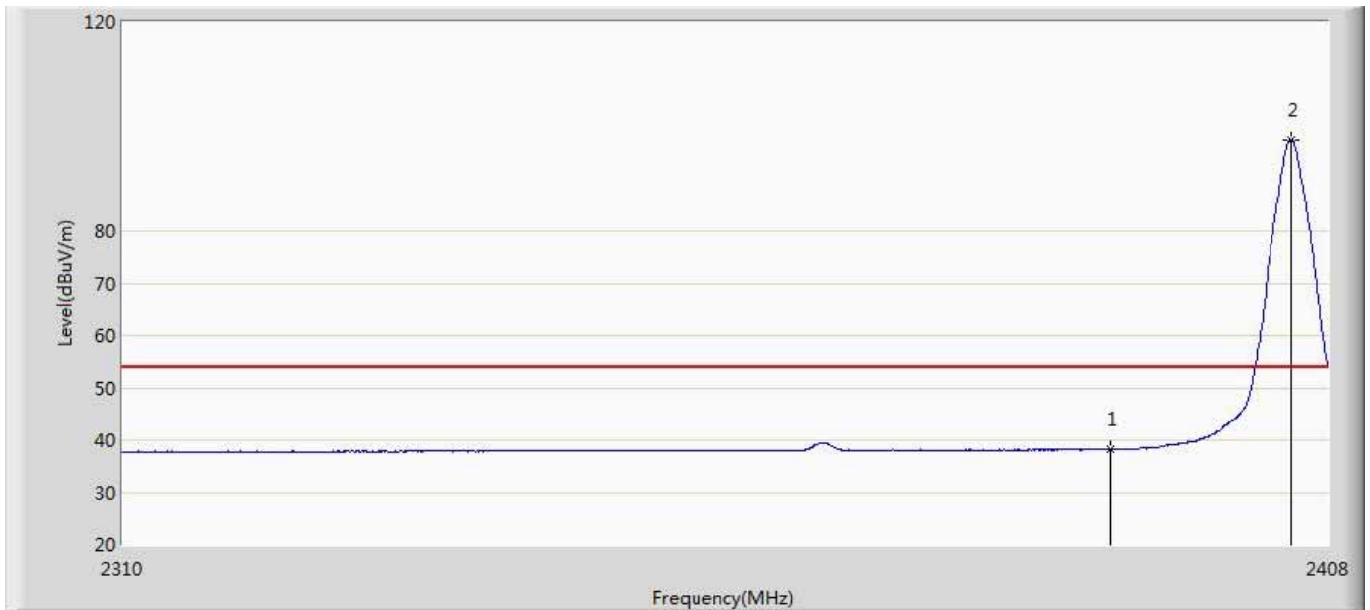

| No | Mark | Frequency (MHz) | Measure Level (dBuV/m) | Reading Level (dBuV) | Over Limit (dB) | Limit (dBuV/m) | Factor (dB) | Type |
|----|------|-----------------|------------------------|----------------------|-----------------|----------------|-------------|------|
| 1  |      | 2390.000        | 38.206                 | 2.524                | -15.794         | 54.000         | 35.682      | AV   |
| 2  | *    | 2404.962        | 97.519                 | 61.798               | 43.519          | 54.000         | 35.721      | AV   |



|  |                          |
|--|--------------------------|
| Engineer: Tongben                          |                          |
| Site: AC5                                  | Time: 2019/08/17 - 17:12 |
| Limit: FCC_Part15.209_RE(3m)               | Margin: 0                |
| Probe: Horn_3117_00167055(1-18GHz)         | Polarity: Vertical       |
| EUT: LED lamp                              | Power: AC 120V/60Hz      |
| Note: Mode 1:Transmit at 2405MHz by Zigbee |                          |

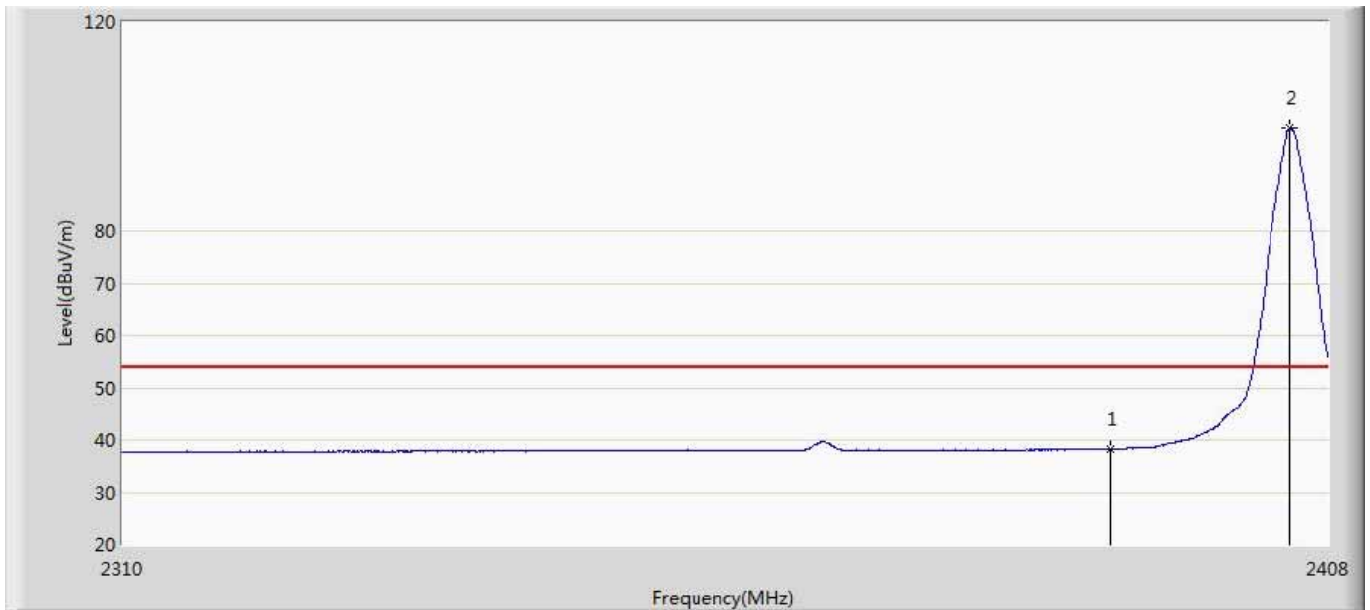

| No | Mark | Frequency (MHz) | Measure Level (dBuV/m) | Reading Level (dBuV) | Over Limit (dB) | Limit (dBuV/m) | Factor (dB) | Type |
|----|------|-----------------|------------------------|----------------------|-----------------|----------------|-------------|------|
| 1  |      | 2390.000        | 38.279                 | 2.597                | -15.721         | 54.000         | 35.682      | AV   |
| 2  | *    | 2404.864        | 99.672                 | 63.952               | 45.672          | 54.000         | 35.721      | AV   |

|  |                          |
|--|--------------------------|
| Engineer: Tongben                          |                          |
| Site: AC5                                  | Time: 2019/08/17 - 17:41 |
| Limit: FCC_Part15.209_RE(3m)               | Margin: 0                |
| Probe: Horn_3117_00167055(1-18GHz)         | Polarity: Horizontal     |
| EUT: LED lamp                              | Power: AC 120V/60Hz      |
| Note: Mode 1:Transmit at 2480MHz by Zigbee |                          |

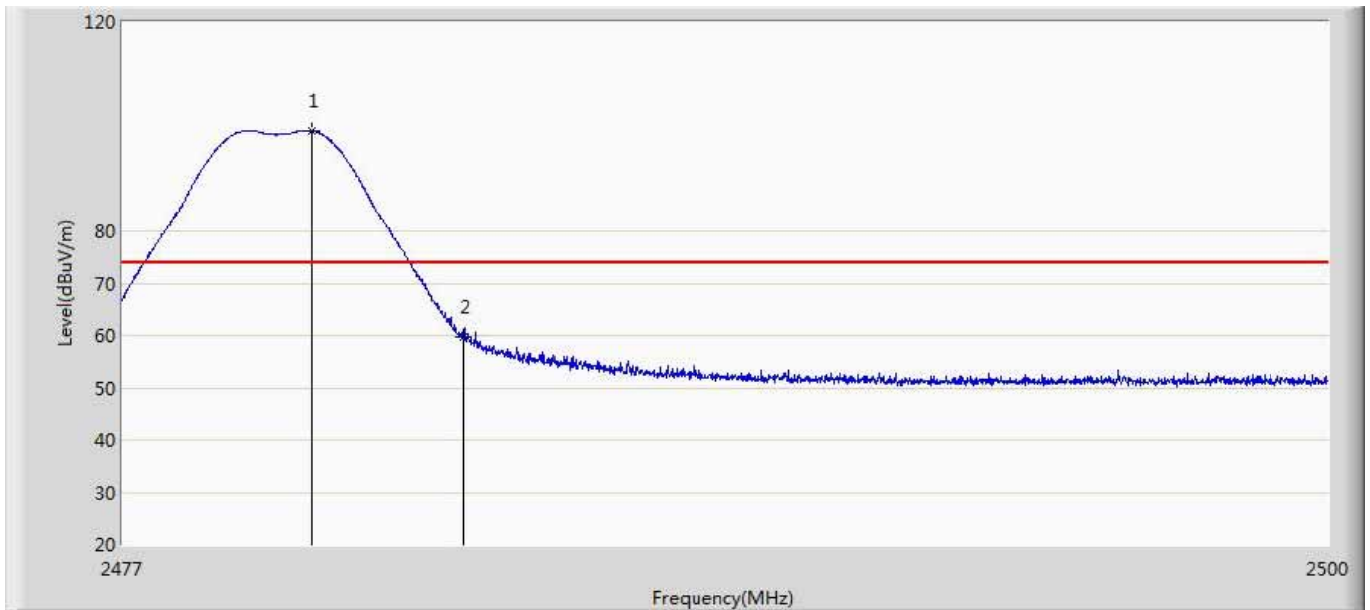

| No | Mark | Frequency (MHz) | Measure Level (dBuV/m) | Reading Level (dBuV) | Over Limit (dB) | Limit (dBuV/m) | Factor (dB) | Type |
|----|------|-----------------|------------------------|----------------------|-----------------|----------------|-------------|------|
| 1  | *    | 2480.611        | 99.053                 | 63.182               | 25.053          | 74.000         | 35.871      | PK   |
| 2  |      | 2483.500        | 59.736                 | 23.844               | -14.264         | 74.000         | 35.891      | PK   |

|  |                          |
|--|--------------------------|
| Engineer: Tongben                          |                          |
| Site: AC5                                  | Time: 2019/08/17 - 17:44 |
| Limit: FCC_Part15.209_RE(3m)               | Margin: 0                |
| Probe: Horn_3117_00167055(1-18GHz)         | Polarity: Vertical       |
| EUT: LED lamp                              | Power: AC 120V/60Hz      |
| Note: Mode 1:Transmit at 2480MHz by Zigbee |                          |

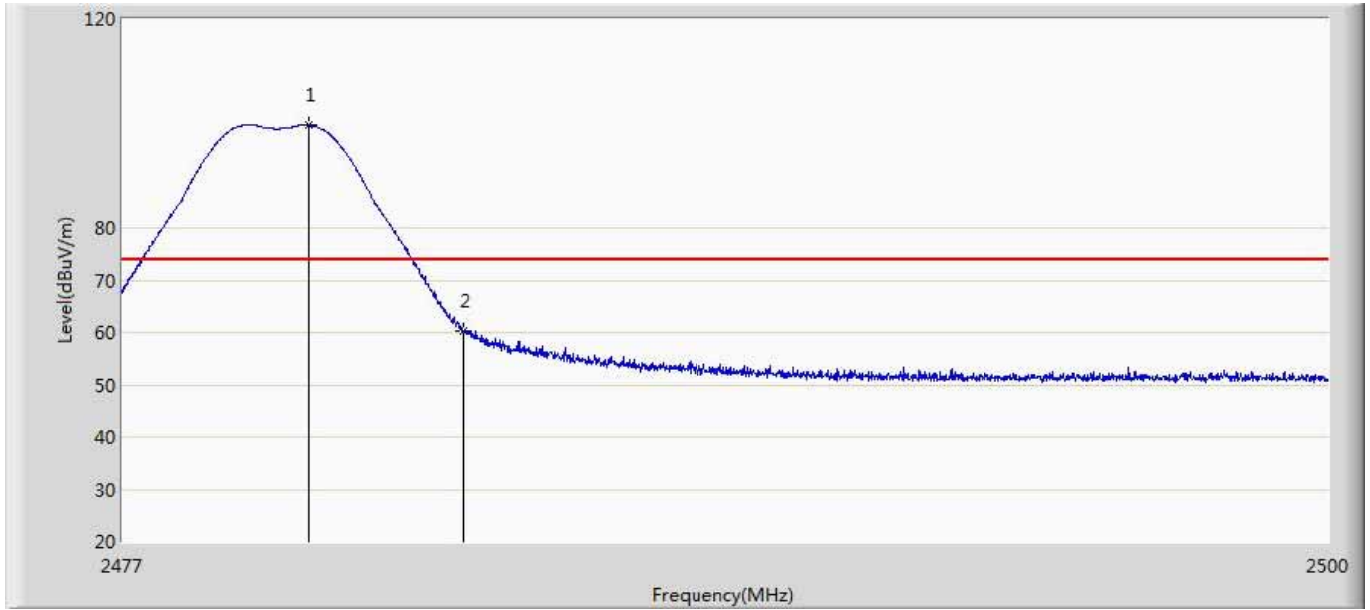

| No | Mark | Frequency (MHz) | Measure Level (dBuV/m) | Reading Level (dBuV) | Over Limit (dB) | Limit (dBuV/m) | Factor (dB) | Type |
|----|------|-----------------|------------------------|----------------------|-----------------|----------------|-------------|------|
| 1  | *    | 2480.553        | 99.672                 | 63.802               | 25.672          | 74.000         | 35.871      | PK   |
| 2  |      | 2483.500        | 60.156                 | 24.264               | -13.844         | 74.000         | 35.891      | PK   |

|  |                          |
|--|--------------------------|
| Engineer: Tongben                          |                          |
| Site: AC5                                  | Time: 2019/08/17 - 17:46 |
| Limit: FCC_Part15.209_RE(3m)               | Margin: 0                |
| Probe: Horn_3117_00167055(1-18GHz)         | Polarity: Horizontal     |
| EUT: LED lamp                              | Power: AC 120V/60Hz      |
| Note: Mode 1:Transmit at 2480MHz by Zigbee |                          |

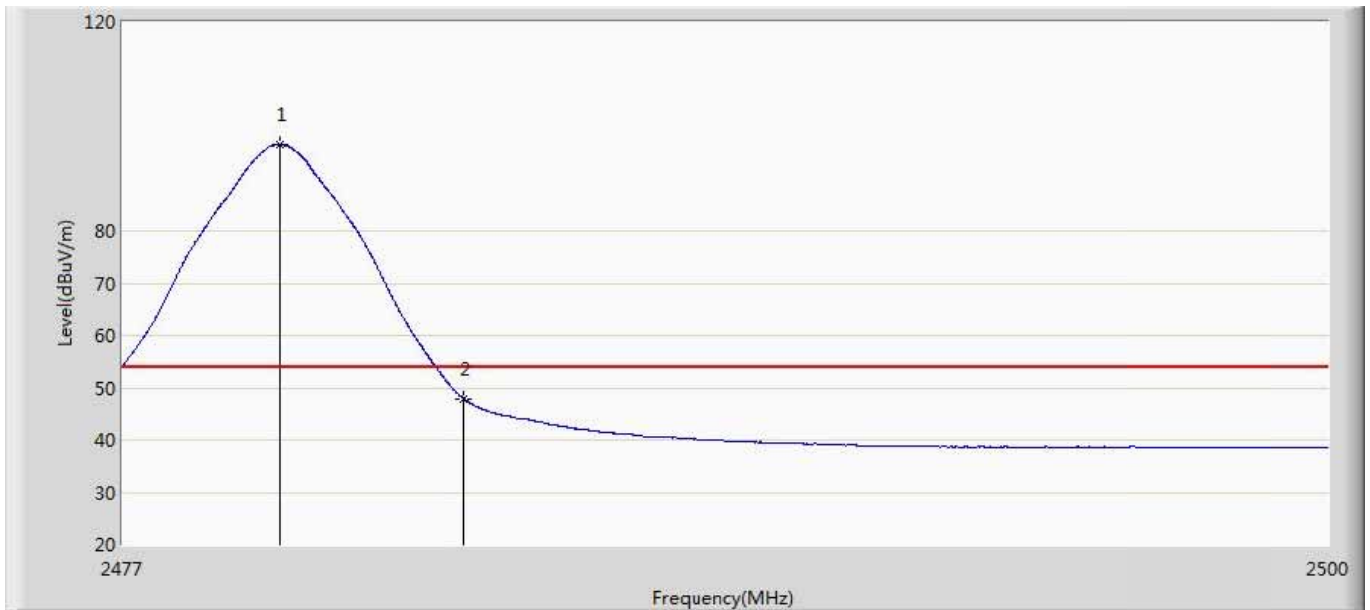

| No | Mark | Frequency (MHz) | Measure Level (dBuV/m) | Reading Level (dBuV) | Over Limit (dB) | Limit (dBuV/m) | Factor (dB) | Type |
|----|------|-----------------|------------------------|----------------------|-----------------|----------------|-------------|------|
| 1  | *    | 2480.001        | 96.550                 | 60.684               | 42.550          | 54.000         | 35.866      | AV   |
| 2  |      | 2483.500        | 47.909                 | 12.017               | -6.091          | 54.000         | 35.891      | AV   |

|  |                          |
|--|--------------------------|
| Engineer: Tongben                          |                          |
| Site: AC5                                  | Time: 2019/08/17 - 17:48 |
| Limit: FCC_Part15.209_RE(3m)               | Margin: 0                |
| Probe: Horn_3117_00167055(1-18GHz)         | Polarity: Vertical       |
| EUT: LED lamp                              | Power: AC 120V/60Hz      |
| Note: Mode 1:Transmit at 2480MHz by Zigbee |                          |

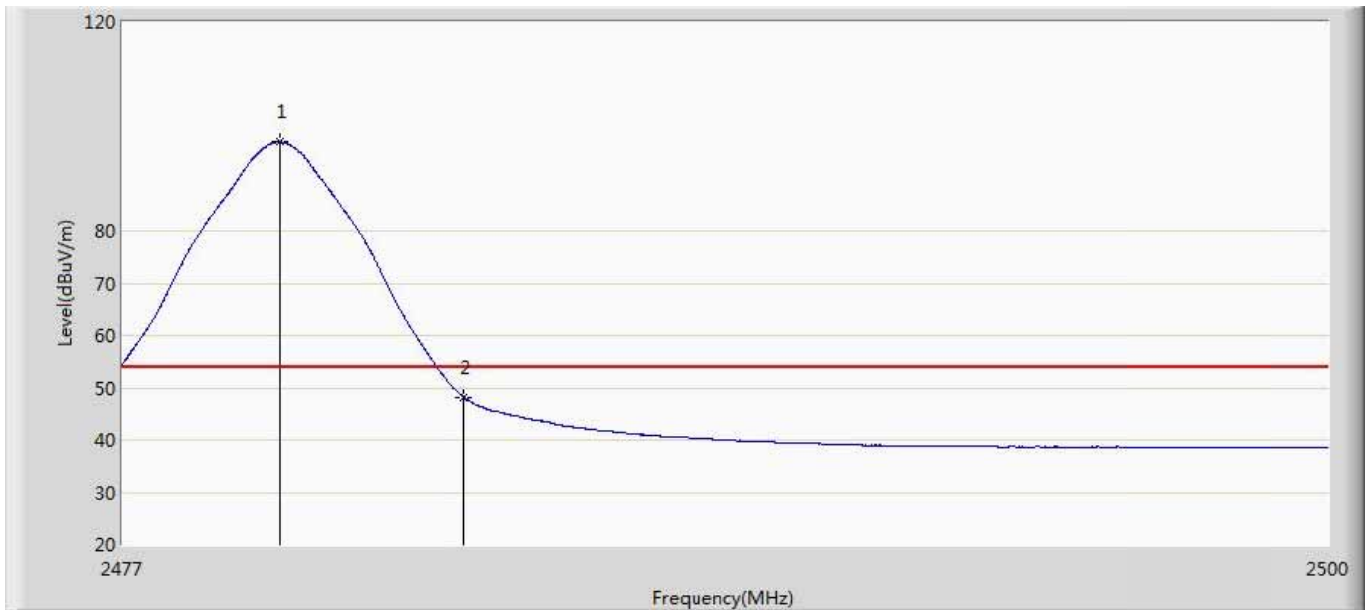

| No | Mark | Frequency (MHz) | Measure Level (dBuV/m) | Reading Level (dBuV) | Over Limit (dB) | Limit (dBuV/m) | Factor (dB) | Type |
|----|------|-----------------|------------------------|----------------------|-----------------|----------------|-------------|------|
| 1  | *    | 2480.001        | 97.004                 | 61.138               | 43.004          | 54.000         | 35.866      | AV   |
| 2  |      | 2483.500        | 48.212                 | 12.320               | -5.788          | 54.000         | 35.891      | AV   |

## 7. Occupied Bandwidth

### 7.1. Test Equipment

| Occupied Bandwidth / TR-8  |              |          |            |            |               |
|----------------------------|--------------|----------|------------|------------|---------------|
| Instrument                 | Manufacturer | Type No. | Serial No. | Cal. Date  | Cal. Due Date |
| Spectrum Analyzer          | Agilent      | N9010A   | MY48030494 | 2019.02.04 | 2020.02.03    |
| EXA Spectrum Analyzer      | Keysight     | N9010A   | MY55370495 | 2019.04.09 | 2020.04.08    |
| MXA Signal Analyzer        | Keysight     | N9020A   | MY56060147 | 2019.04.09 | 2020.04.08    |
| Temperature/Humidity Meter | zhichen      | ZC1-2    | TR8-TH     | 2019.04.10 | 2020.04.09    |

Note: All equipments are calibrated with traceable calibrations. Each calibration is traceable to the national or international standards.

### 7.2. Test Setup

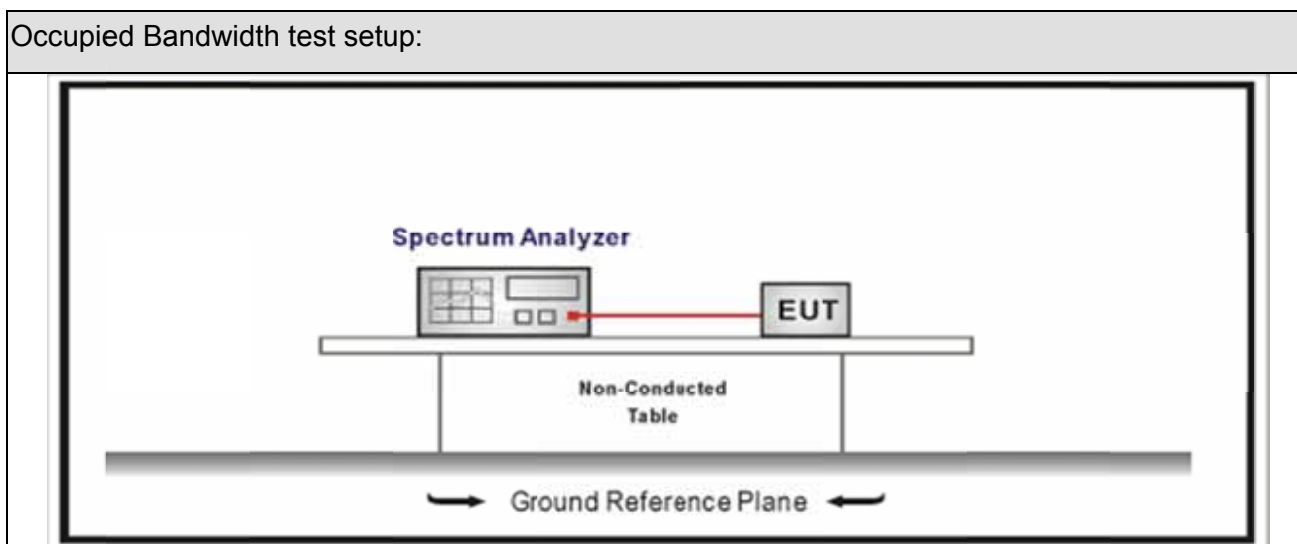



### 7.3. Limit

|  |
|--|
| Occupied Bandwidth   |
| Systems using digital modulation techniques operate in the 2400-2483.5 MHz. The minimum 6 dB bandwidth shall be at least 500 kHz |

### 7.4. Test Procedure

| Test Method                         |   |         |               |
|-------------------------------------|---|---------|---------------|
|                                     | Reference Rule                                  | Chapter | Description   |
| <input checked="" type="checkbox"/> | ANSI C63.10                                     | 11.8    | DTS bandwidth |
|                                     | <input type="checkbox"/> ANSI C63.10            | 11.8.1  | Option 1      |
|                                     | <input checked="" type="checkbox"/> ANSI C63.10 | 11.8.2  | Option 2      |

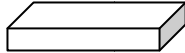
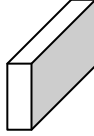
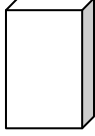
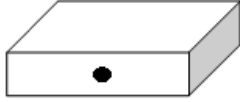
**7.5. EUT test definition**

| Item            | Occupied Bandwidth   |  |  |  |
|-----------------|--|--|--|--|
| Device Category | <input type="checkbox"/>   | Fixed point-to-point   |  |  |
|                 | <input type="checkbox"/>   | Emit multiple directional beams, simultaneously or sequentially                      |  |  |
|                 | <input checked="" type="checkbox"/>  | Other cases  |  |  |
| Test mode       | Mode 1   |  |  |  |
| Test method     | <input type="checkbox"/>   | Radiated   |  |  |
|                 |  | X Axis   | Y Axis   | Z Axis   |
|                 |  |     |  |  |
|                 |  | Worst Axis <input type="checkbox"/>  | Worst Axis <input type="checkbox"/>  | Worst Axis <input type="checkbox"/>  |
|                 | <input checked="" type="checkbox"/>  | Conducted  |  |  |
|                 | <input checked="" type="checkbox"/>  | Chain 0  |  |  |
|                 |  |  |  |  |
|                 | <input type="checkbox"/>   | Chain 0  | Chain 1  |  |
|                 |  |  |  |  |
|                 | <input type="checkbox"/>   | Chain 0  | Chain 1  | Chain 2  |
|                 |  |  |  |  |



### 7.6. Test Result

|              |              |           |                |
|--------------|--------------|-----------|----------------|
| Product Name | : LED lamp   | Power     | : AC 120V/60Hz |
| Test Mode    | : Mode 1     | Test Site | : TR-8         |
| Test Date    | : 2019.08.15 |           |                |

| Mode | CH. | Test Freq. (MHz) | 99% Occupied Bandwidth (kHz) | 6dB Occupied Bandwidth (kHz) | Limit (kHz) | Result |
|------|-----|------------------|------------------------------|------------------------------|-------------|--------|
| 1    | 11  | 2405             | 2305                         | 1775                         | >500        | Pass   |
| 1    | 18  | 2440             | 2308.7                       | 1717                         | >500        | Pass   |
| 1    | 26  | 2480             | 2317.5                       | 1544                         | >500        | Pass   |

Note : The worst case of Occupied Bandwidth as below:

#### Mode 1 CH11 (2405MHz)

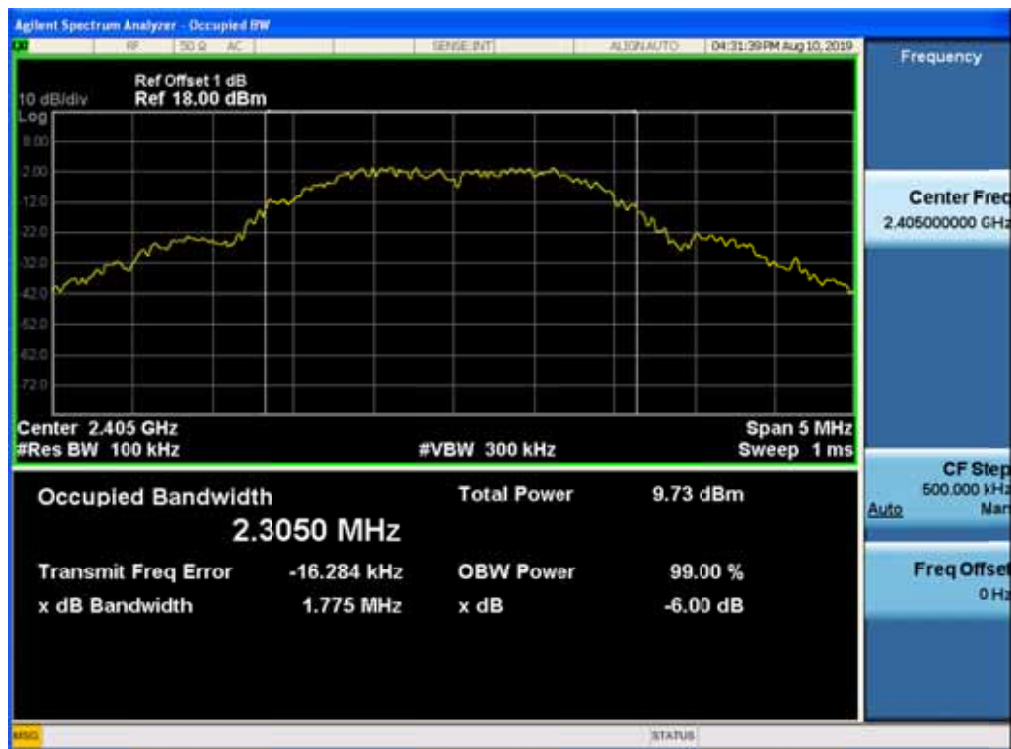

### Mode 1 CH18 (2440MHz)

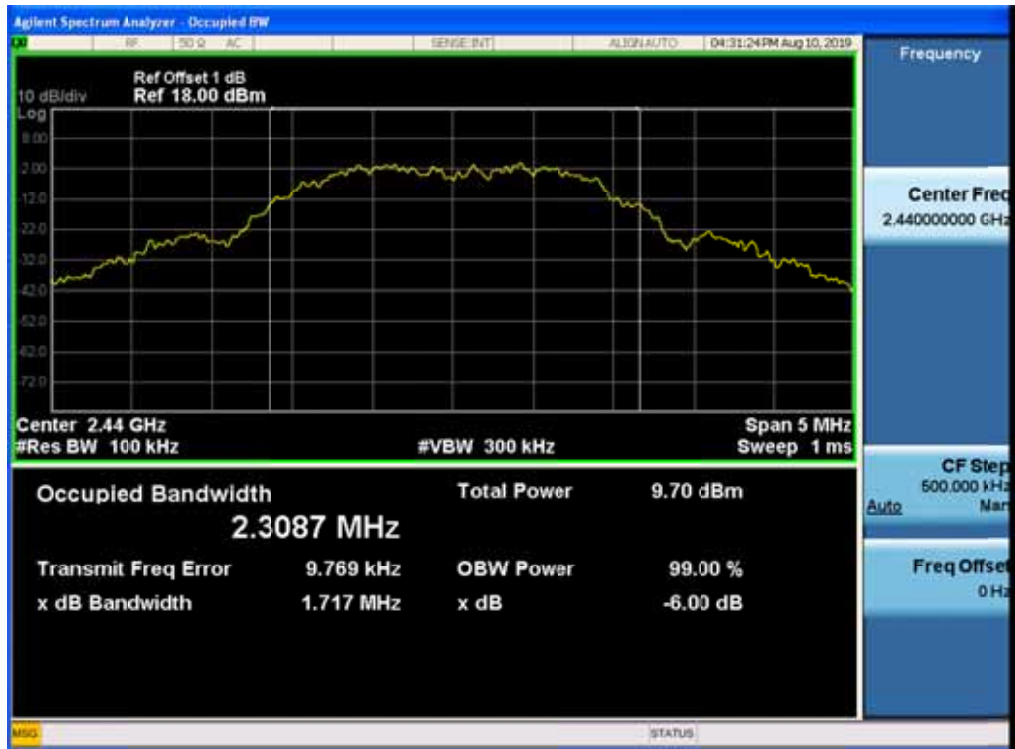

### Mode 1 CH39 (2480MHz)

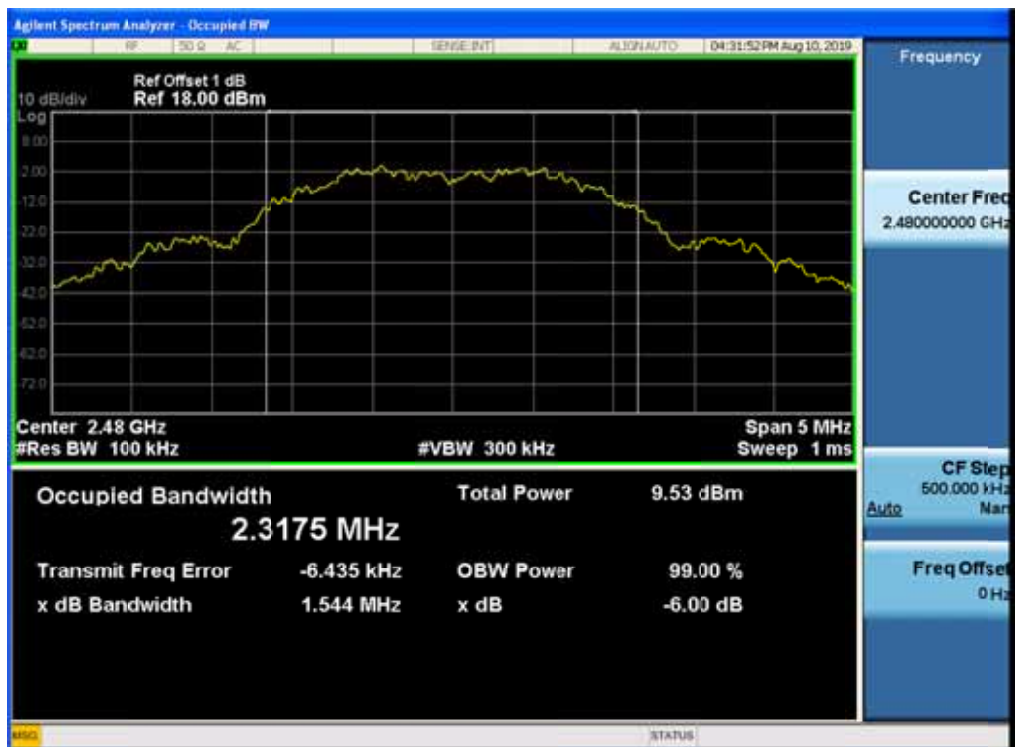

## 8. Fundamental emission output power

### 8.1. Test Equipment

| Fundamental emission output power/ TR-8 |              |          |            |            |               |
|---|--------------|----------|------------|------------|---------------|
| Instrument                              | Manufacturer | Type No. | Serial No. | Cal. Date  | Cal. Due Date |
| Spectrum Analyzer                       | Agilent      | E4446A   | MY45300103 | 2019.01.04 | 2020.01.03    |
| Spectrum Analyzer                       | Agilent      | N9010A   | MY48030494 | 2019.02.04 | 2020.01.15    |
| Wideband Peak Power Meter               | Anritsu      | ML2495A  | 0905006    | 2018.10.14 | 2019.10.13    |
| Power Sensor                            | Anritsu      | MA2411B  | 0846014    | 2018.10.14 | 2019.10.13    |
| Temperature/Humidity Meter              | zhicheng     | ZC1-2    | TR8-TH     | 2019.04.10 | 2020.04.09    |

Note: All equipments are calibrated with traceable calibrations. Each calibration is traceable to the national or international standards.

### 8.2. Test Setup

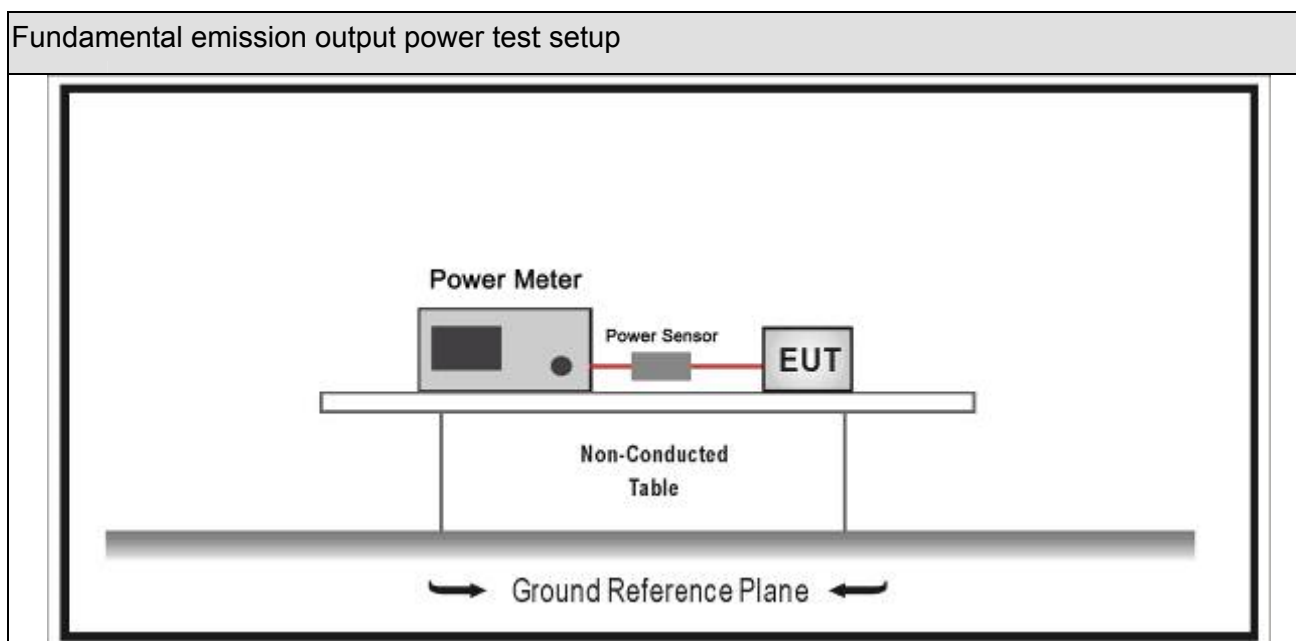



### 8.3. Limit

| Fundamental emission output power Limit  |   |   |
|--|---|---|
| <input checked="" type="checkbox"/>  | $G_{TX} < 6\text{dBi}$                                  | $P_{out} \leq 30\text{dBm}$                       |
| <input type="checkbox"/>   | $G_{TX} > 6\text{dBi}$                                  |   |
| <input type="checkbox"/>   | Non-Fix point-point                                     | $P_{out} \leq 30 - (G_{TX} - 6)$                  |
| <input type="checkbox"/>   | Fix point-point   | $P_{out} \leq 30 - [(G_{TX} - 6)]/3$              |
| <input type="checkbox"/>   | Point-to-multipoint                                     | $P_{out} \leq 30 - (G_{TX} - 6)$                  |
| <input type="checkbox"/>   | Overlap Beams   | $P_{out} \leq 30 - [(G_{TX} - 6)]/3$              |
| <input type="checkbox"/>   | Aggregate power transmitted simultaneously on all beams | $P_{out} \leq 30 - [(G_{TX} - 6)]/3$              |
| <input type="checkbox"/>   | single directional beam                                 | $P_{out} \leq 30 - [(G_{TX} - 6)]/3 + 8\text{dB}$ |
| <p>Note 1 : <math>G_{TX}</math> directional gain of transmitting antennas.</p> <p>Note 2 : <math>P_{out}</math> is maximum peak conducted output power .</p> |   |   |

**8.4. Test Procedure**

| Fundamental emission output power Test Method |                                     |             |                |                                   |  |
|---|-------------------------------------|-------------|----------------|-----------------------------------|--|
|   | References Rule                     |             | Chapter        | Description                       |  |
| <input checked="" type="checkbox"/>           | ANSI C63.10                         |             | 11.9           | Fundamental emission output power |  |
|   | <input checked="" type="checkbox"/> | ANSI C63.10 |                | 11.9.1                            | Maximum peak conducted output power        |
|   | <input type="checkbox"/>            | ANSI C63.10 | 11.9.1.1       | RBW ≥ DTS bandwidth               |  |
|   | <input type="checkbox"/>            | ANSI C63.10 | 11.9.1.2       | Integrated band power method      |  |
|   | <input checked="" type="checkbox"/> | ANSI C63.10 | 11.9.1.3       | PKPM1 Peak power meter method     |  |
|   | <input checked="" type="checkbox"/> | ANSI C63.10 |                | 11.9.2                            | Maximum conducted (average) output power   |
|   | <input type="checkbox"/>            | ANSI C63.10 |                | 11.9.2.2                          | Measurement using a spectrum analyzer (SA) |
|   | <input type="checkbox"/>            | ANSI C63.10 | 11.9.2.2.2     | Method AVGSA-1(Duty cycle 98%)    |  |
|   | <input type="checkbox"/>            | ANSI C63.10 | 11.9.2.2.3     | Method AVGSA-1A(Duty cycle 98%)   |  |
|   | <input type="checkbox"/>            | ANSI C63.10 | 11.9.2.2.4     | Method AVGSA-2(Duty cycle 98%)    |  |
|   | <input type="checkbox"/>            | ANSI C63.10 | 11.9.2.2.5     | Method AVGSA-2A(Duty cycle 98%)   |  |
|   | <input type="checkbox"/>            | ANSI C63.10 | 11.9.2.2.4     | Method AVGSA-3                    |  |
|   | <input type="checkbox"/>            | ANSI C63.10 | 11.9.2.2.5     | Method AVGSA-3A                   |  |
|   | <input checked="" type="checkbox"/> | ANSI C63.10 |                | 11.9.2.3                          | Measurement using a power meter (PM)       |
|   | <input checked="" type="checkbox"/> | ANSI C63.10 | 11.9.2.3.1     | Method AVGPM                      |  |
| <input type="checkbox"/>                      | ANSI C63.10                         | 11.9.2.3.2  | Method AVGPM-G |                                   |  |

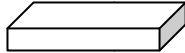
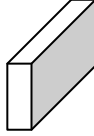
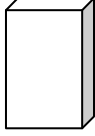
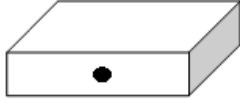
**8.5. EUT test definition**

| Item            | Fundamental emission output power  |  |  |  |
|-----------------|--|--|--|--|
| Device Category | <input type="checkbox"/>   | Fixed point-to-point   |  |  |
|                 | <input type="checkbox"/>   | Emit multiple directional beams, simultaneously or sequentially                      |  |  |
|                 | <input checked="" type="checkbox"/>  | Other cases  |  |  |
| Test mode       | Mode 1   |  |  |  |
| Test method     | <input type="checkbox"/>   | Radiated   |  |  |
|                 |  | X Axis   | Y Axis   | Z Axis   |
|                 |  |     |  |  |
|                 |  | Worst Axis <input type="checkbox"/>  | Worst Axis <input type="checkbox"/>  | Worst Axis <input type="checkbox"/>  |
|                 | <input checked="" type="checkbox"/>  | Conducted  |  |  |
|                 | <input checked="" type="checkbox"/>  | Chain 0  |  |  |
|                 |  |  |  |  |
|                 | <input type="checkbox"/>   | Chain 0  | Chain 1  |  |
|                 |  |  |  |  |
|                 | <input type="checkbox"/>   | Chain 0  | Chain 1  | Chain 2  |
|                 |  |  |  |  |

## 8.6. Test Result

|              |              |           |                |
|--------------|--------------|-----------|----------------|
| Product Name | : LED lamp   | Power     | : AC 120V/60Hz |
| Test Mode    | : Mode 1     | Test Site | : TR-8         |
| Test Date    | : 2019.08.16 |           |                |

### Muruta:

| Mode | Channel | Test Frequency (MHz) | Measurement Power Output (dBm) | Limit (dBm) | Result |
|------|---------|----------------------|--------------------------------|-------------|--------|
| 1    | 11      | 2405                 | 9.49                           | 30          | Pass   |
| 1    | 18      | 2440                 | 9.51                           | 30          | Pass   |
| 1    | 26      | 2480                 | 9.02                           | 30          | Pass   |

### Diodes:

| Mode | Channel | Test Frequency (MHz) | Measurement Power Output (dBm) | Limit (dBm) | Result |
|------|---------|----------------------|--------------------------------|-------------|--------|
| 1    | 11      | 2405                 | 9.46                           | 30          | Pass   |
| 1    | 18      | 2440                 | 9.48                           | 30          | Pass   |
| 1    | 26      | 2480                 | 9.42                           | 30          | Pass   |

## 9. Power Spectral Density

### 9.1. Test Equipment

| Power Spectral Density / TR-8 |              |          |            |            |               |
|-------------------------------|--------------|----------|------------|------------|---------------|
| Instrument                    | Manufacturer | Type No. | Serial No. | Cal. Date  | Cal. Due Date |
| Spectrum Analyzer             | Agilent      | N9010A   | MY48030494 | 2019.02.04 | 2020.02.03    |
| EXA Spectrum Analyzer         | Keysight     | N9010A   | MY55370495 | 2019.04.09 | 2020.04.08    |
| MXA Signal Analyzer           | Keysight     | N9020A   | MY56060147 | 2019.04.09 | 2020.04.08    |
| Temperature/Humidity Meter    | zhichen      | ZC1-2    | TR8-TH     | 2019.04.10 | 2020.04.09    |

Note: All equipments are calibrated with traceable calibrations. Each calibration is traceable to the national or international standards.

### 9.2. Test Setup

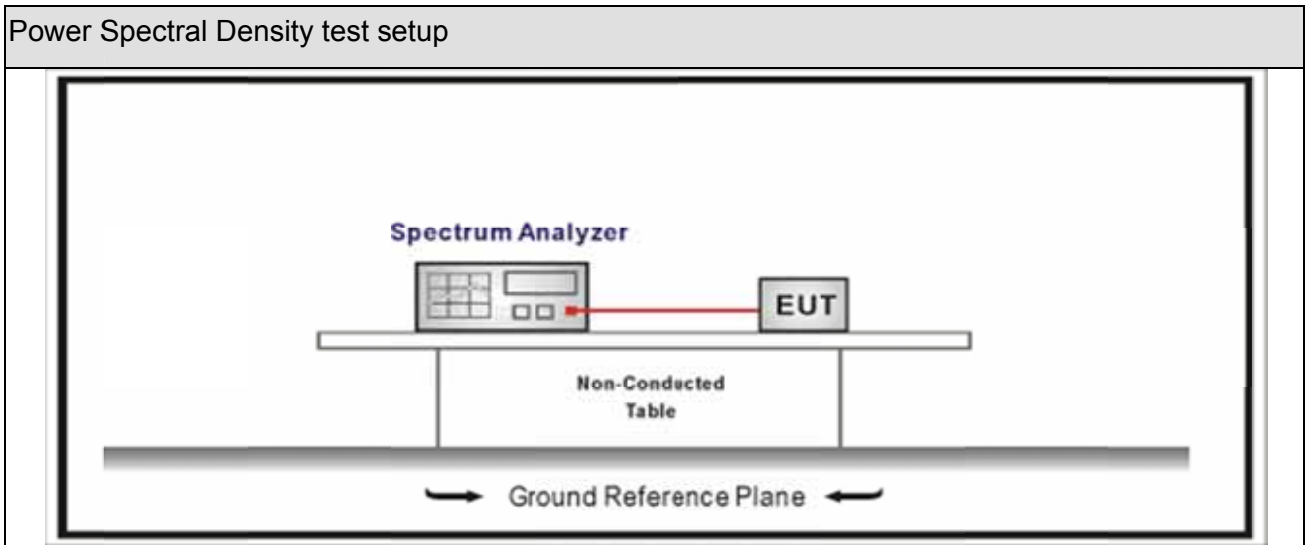

### 9.3. Limit



| Power Spectral Density Limit     |
|----------------------------------|
| Power Spectral Density 8dBm/3kHz |



### 9.4. Test Procedure

| Power Spectral Density Test Method  |                 |         |  |
|-------------------------------------|-----------------|---------|--|
|                                     | References Rule | Chapter | Description  |
| <input checked="" type="checkbox"/> | ANSI C63.10     | 11.10   | Maximum power spectral density level in the fundamental emission |
| <input checked="" type="checkbox"/> | ANSI C63.10     | 11.10.2 | Method PKPSD (peak PSD)  |
| <input type="checkbox"/>            | ANSI C63.10     | 11.10.3 | Method AVGPSD-1(Duty cycle 98%)                                  |
| <input type="checkbox"/>            | ANSI C63.10     | 11.10.4 | Method AVGPSD-1A(Duty cycle 98%)                                 |
| <input type="checkbox"/>            | ANSI C63.10     | 11.10.5 | Method AVGPSD-2(Duty cycle < 98%)                                |
| <input type="checkbox"/>            | ANSI C63.10     | 11.10.6 | Method AVGPSD-2A(Duty cycle < 98%)                               |
| <input type="checkbox"/>            | ANSI C63.10     | 11.10.7 | Method AVGPSD-3  |
| <input type="checkbox"/>            | ANSI C63.10     | 11.10.8 | Method AVGPSD-3A   |

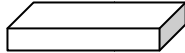
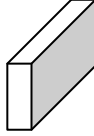
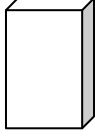
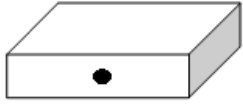
**9.5. EUT test definition**

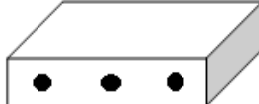
| Item            | Power Spectral Density Test Method   |  |  |  |
|-----------------|--|--|--|--|
| Device Category | <input type="checkbox"/>   | Fixed point-to-point   |  |  |
|                 | <input type="checkbox"/>   | Emit multiple directional beams, simultaneously or sequentially                      |  |  |
|                 | <input checked="" type="checkbox"/>  | Other cases  |  |  |
| Test mode       | Mode 1   |  |  |  |
| Test method     | <input type="checkbox"/>   | Radiated   |  |  |
|                 |  | X Axis   | Y Axis   | Z Axis   |
|                 |  |     |  |  |
|                 |  | Worst Axis <input type="checkbox"/>  | Worst Axis <input type="checkbox"/>  | Worst Axis <input type="checkbox"/>  |
|                 | <input checked="" type="checkbox"/>  | Conducted  |  |  |
|                 | <input checked="" type="checkbox"/>  | Chain 0  |  |  |
|                 |  |  |  |  |
|                 | <input type="checkbox"/>   | Chain 0  | Chain 1  |  |
|                 |  |  |  |  |
|                 | <input type="checkbox"/>   | Chain 0  | Chain 1  | Chain 2  |
|                 |  |  |  |  |

**9.6. Test Result**

|              |              |           |                |
|--------------|--------------|-----------|----------------|
| Product Name | : LED lamp   | Power     | : AC 120V/60Hz |
| Test Mode    | : Mode 1     | Test Site | : TR-8         |
| Test Date    | : 2019.08.16 |           |                |

| Mode | Channel | Test Frequency (MHz) | Measurement PSD (dBm/3kHz) | Total PSD (dBm/3kHz) | Limit (dBm/3kHz) | Result |
|------|---------|----------------------|----------------------------|----------------------|------------------|--------|
| 1    | 11      | 2405                 | -4.895                     | -4.895               | 8                | Pass   |
| 1    | 18      | 2440                 | -5.418                     | -5.418               | 8                | Pass   |
| 1    | 26      | 2480                 | -3.838                     | -3.838               | 8                | Pass   |

Note : The worst case of Power Spectral Density as below:

**Mode 1 CH26(2480MHz)**

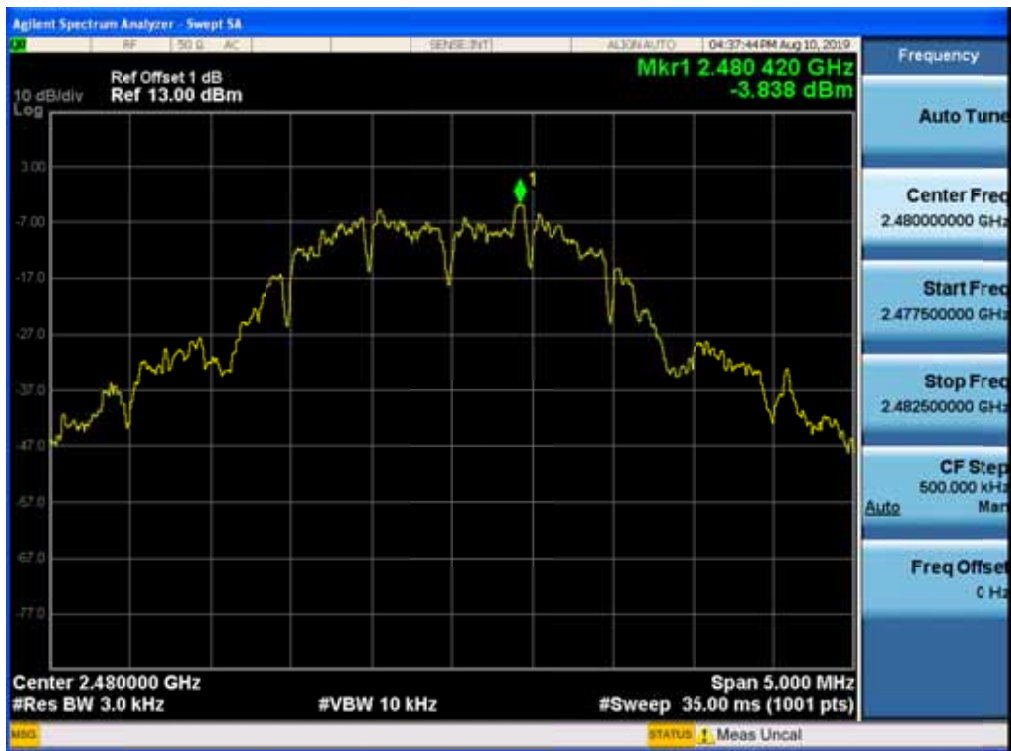

## 10. Antenna Requirement

### 10.1. Limit

| Antenna Requirement Limit   |  |
|---|--|
| <p>An intentional radiator shall be designed to ensure that no antenna other than that furnished by the responsible party shall be used with the device. The use of a permanently attached antenna or of an antenna that uses a unique coupling to the intentional radiator shall be considered sufficient to comply with the provisions of this section. The manufacturer may design the unit so that a broken antenna can be replaced by the user, but the use of a standard antenna jack or electrical connector is prohibited. This requirement does not apply to carrier current devices or to devices operated under the provisions of §15.211, §15.213, §15.217, §15.219, or §15.221. Further, this requirement does not apply to intentional radiators that must be professionally installed, such as perimeter protection systems and some field disturbance sensors, or to other intentional radiators which, in accordance with §15.31(d), must be measured at the installation site. However, the installer shall be responsible for ensuring that the proper antenna is employed so that the limits in this part are not exceeded.</p> |  |

### 10.2. Antenna Connector Construction

| Antenna Connector Construction   |  |
|--|--|
| <input checked="" type="checkbox"/>  | The use of a permanently attached antenna                        |
| <input type="checkbox"/>   | The antenna use of a unique coupling to the intentional radiator |
| <input type="checkbox"/>   | The use of a nonstandard antenna jack or electrical connector    |
| Please refer to the attached document "Internal Photograph" to show the antenna connector. |  |

\_\_\_\_\_ The End \_\_\_\_\_