



# Test Report

## FCC Part15 Subpart C & RSS-247 Issue 2

Product Name : LED lamp  
Model No. : 9290022176  
FCC ID : 2AGBW9290022176X  
IC : 20812-2176X

Applicant : Signify (China) Investment Co., Ltd.  
Address : Building no.9, Lane 888, Tianlin Road, Minhang  
District, Shanghai 200233, China

Date of Receipt : Nov. 02, 2018  
Test Date : Nov. 02, 2018~ Nov. 26, 2018  
Issued Date : Mar. 11, 2019  
Report No. : 18B2026R-RF-US-P06V02  
Report Version : V1.0

The test results relate only to the samples tested.

The test results shown in the test report are traceable to the national/international standard through the calibration of the equipment and evaluated measurement uncertainty herein.

This report must not be used to claim product endorsement by TAF, A2LA or any agency of the government.

The test report shall not be reproduced without the written approval of DEKRA Testing & Certification (Suzhou) Co., Ltd.

# Test Report Certification

Issued Date : Mar. 11, 2019  
Report No. : 18B2026R-RF-US-P06V02



Product Name : LED lamp  
 Applicant : Signify (China) Investment Co., Ltd.  
 Address : Building no.9, Lane 888, Tianlin Road, Minhang District, Shanghai 200233, China  
 Manufacturer : Signify (China) Investment Co., Ltd.  
 Address : Building no.9, Lane 888, Tianlin Road, Minhang District, Shanghai 200233, China  
 Model No. : 9290022176  
 FCC ID : 2AGBW9290022176X  
 IC : 20812-2176X  
 Brand Name : Philips  
 EUT Voltage : 110-130Vac, 50-60 Hz, 7.5W  
 Test Voltage : AC 120V/60Hz  
 Applicable Standard : FCC CFR Title 47 Part 15 Subpart C  
 ANSI C63.10:2013  
 KDB 558074 D01v05  
 RSS-Gen Issue 5 / RSS-247 Issue 2  
 Test Result : Complied  
 Performed Location : DEKRA Testing & Certification (Suzhou) Co., Ltd.  
 No.99 Hongye Rd., Suzhou Industrial Park, Suzhou, 215006, Jiangsu, China  
 TEL: +86-512-6251-5088 / FAX: +86-512-6251-5098  
 FCC Designation Number: CN1199; ISED Lab Code: 4075B

Documented By : Kathy Feng  
 ( Project Assistant: Kathy Feng)

Reviewed By : Frank He  
 (Senior Project Manager: Frank He )

Approved By : Jack Zhang  
 (Engineer Supervisor: Jack Zhang )

## TABLE OF CONTENTS

Description	Page
1. General Information.....	6
1.1. EUT Description.....	6
1.2. Working Frequency of Each Channel:.....	7
1.3. Antenna information.....	7
1.4. Mode of Operation.....	8
1.5. Tested System Details.....	8
1.6. Configuration of Tested System.....	9
1.7. EUT Exercise Software.....	10
2. Technical Test.....	11
2.1. Summary of Test Result.....	11
2.2. Test Environment.....	13
2.3. Measurement Uncertainty.....	13
3. AC Power Line Conducted Emission.....	14
3.1. Test Equipment.....	14
3.2. Test Setup.....	14
3.3. Limit.....	15
3.4. Test Procedure.....	15
3.5. Test Result.....	16
4. Emissions in restricted frequency bands.....	22
4.1. Test Equipment.....	22
4.2. Test Setup.....	23
4.3. Limit.....	24
4.4. Test Procedure.....	27
4.5. EUT test Axis definition.....	28
4.6. Test Result.....	29
5. Emissions in non-restricted frequency bands.....	53
5.1. Test Equipment.....	53
5.2. Test Setup.....	53
5.3. Limit.....	54
5.4. Test Procedure.....	55
5.5. EUT test Axis definition.....	56
5.6. Test Result.....	57
6. Radiated Emission Band Edge.....	58
6.1. Test Equipment.....	58
6.2. Test Setup.....	59
6.3. Limit.....	59
6.4. Test Procedure.....	60

- 6.5. EUT test definition..... 61
- 6.6. Duty Cycle.....62
- 6.7. Test Result.....63
- 7. Occupied Bandwidth..... 63
- 7.1. Test Equipment..... 87
- 7.2. Test Setup..... 87
- 7.3. Limit..... 88
- 7.4. Test Procedure..... 88
- 7.5. EUT test definition..... 89
- 7.6. Test Result..... 90
- 8. Fundamental emission output power..... 91
- 8.1. Test Equipment..... 91
- 8.2. Test Setup..... 91
- 8.3. Limit..... 92
- 8.4. Test Procedure..... 93
- 8.5. EUT test definition..... 94
- 8.6. Test Result..... 95
- 9. Power Spectral Density..... 96
- 9.1. Test Equipment..... 96
- 9.2. Test Setup..... 96
- 9.3. Limit..... 96
- 9.4. Test Procedure..... 97
- 9.5. EUT test definition..... 98
- 9.6. Test Result..... 99
- 10. Antenna Requirement..... 100
- 10.1. Limit..... 100
- 10.2. Antenna Connector Construction..... 100

### History of This Test Report

REPORT NO.	VERSION	DESCRIPTION	ISSUED DATE
18B2026R-RF-US-P06V02	V1.0	Initial Issued Report	Mar. 11, 2019

**1. General Information**

**1.1. EUT Description**

Product Name	LED lamp
Brand Name	Philips
Model No.	9290022176
EUT Voltage	110-130Vac, 50-60 Hz, 7.5W
Frequency Range	2405 ~ 2480MHz
Channel Number	16
Type of Modulation	O-QPSK
Data Rate	250kbps
Antenna Type	Reference to Antenna List
Peak Antenna Gain	Reference to Antenna List

Note: Hue White and Color/BR30 supports two kinds of lighting source (APT/LTN), and two kinds of Crystal oscillator (Diode (FL3840023)\_2017/ Murata(XRCGB38M400FXH17R0)), there is not any change in RF design, circuitry or construction for this device, including RF parameters (antenna, software, firmware and hardware versions, power, frequency ranges, etc.), so only spurious emission and bandedge were tested for additional light source and crystal oscillator combinations, and we use the worst combination for all other test items of RF compliance.

**1.2. Working Frequency of Each Channel:**

Zigbee Working Frequency of Each Channel:							
Channel	Frequency	Channel	Frequency	Channel	Frequency	Channel	Frequency
11	2405 MHz	12	2410 MHz	13	2415 MHz	14	2420 MHz
15	2425 MHz	16	2430 MHz	17	2435 MHz	18	2440 MHz
19	2445 MHz	20	2450 MHz	21	2455 MHz	22	2460 MHz
23	2465 MHz	24	2470 MHz	25	2475 MHz	26	2480 MHz

**1.3. Antenna information**

Antenna manufacturer	N/A					
Antenna Delivery	<input checked="" type="checkbox"/>	1*TX+1*RX	<input type="checkbox"/>	2*TX+2*RX	<input type="checkbox"/>	3*TX+3*RX
Antenna technology	<input checked="" type="checkbox"/>	SISO				
	<input type="checkbox"/>	MIMO	<input type="checkbox"/>	Basic		
			<input type="checkbox"/>	CDD		
			<input type="checkbox"/>	Beam-forming		
Antenna Type	<input type="checkbox"/>	External	<input type="checkbox"/>	Dipole		
	<input checked="" type="checkbox"/>	Internal	<input type="checkbox"/>	PIFA		
			<input checked="" type="checkbox"/>	PCB		
			<input type="checkbox"/>	Ceramic Chip Antenna		
			<input type="checkbox"/>	Metal plate type F antenna		
Antenna Gain	4.2dBi					

### 1.4. Mode of Operation

DEKRA has verified the construction and function in typical operation. See the different modes shown in this test report and defined as:

Test Modes List
Mode 1: Transmit by Zigbee

### 1.5. Tested System Details

The types for all equipment, plus descriptions of all cables used in the tested system (including inserted cards) are:

No.	Product	Manufacturer	Model No.	Serial No.	Power Cord
1	Notebook	Think Pad	2526	LV-A3285	Power by adapter
A	USB Control Cable	N/A	N/A	N/A	Shield, 1m
B	USB Control Cable	N/A	N/A	N/A	Shield, 10m



### 1.6. Configuration of Tested System

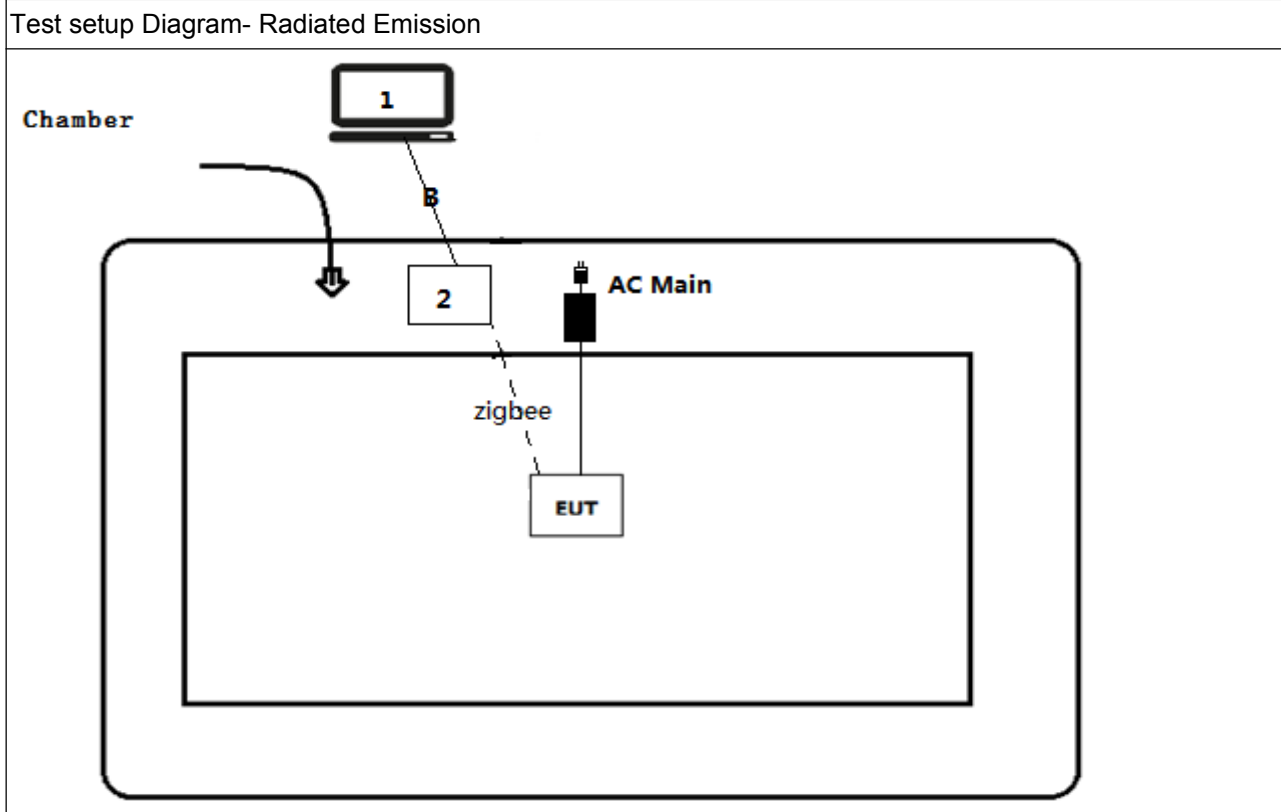
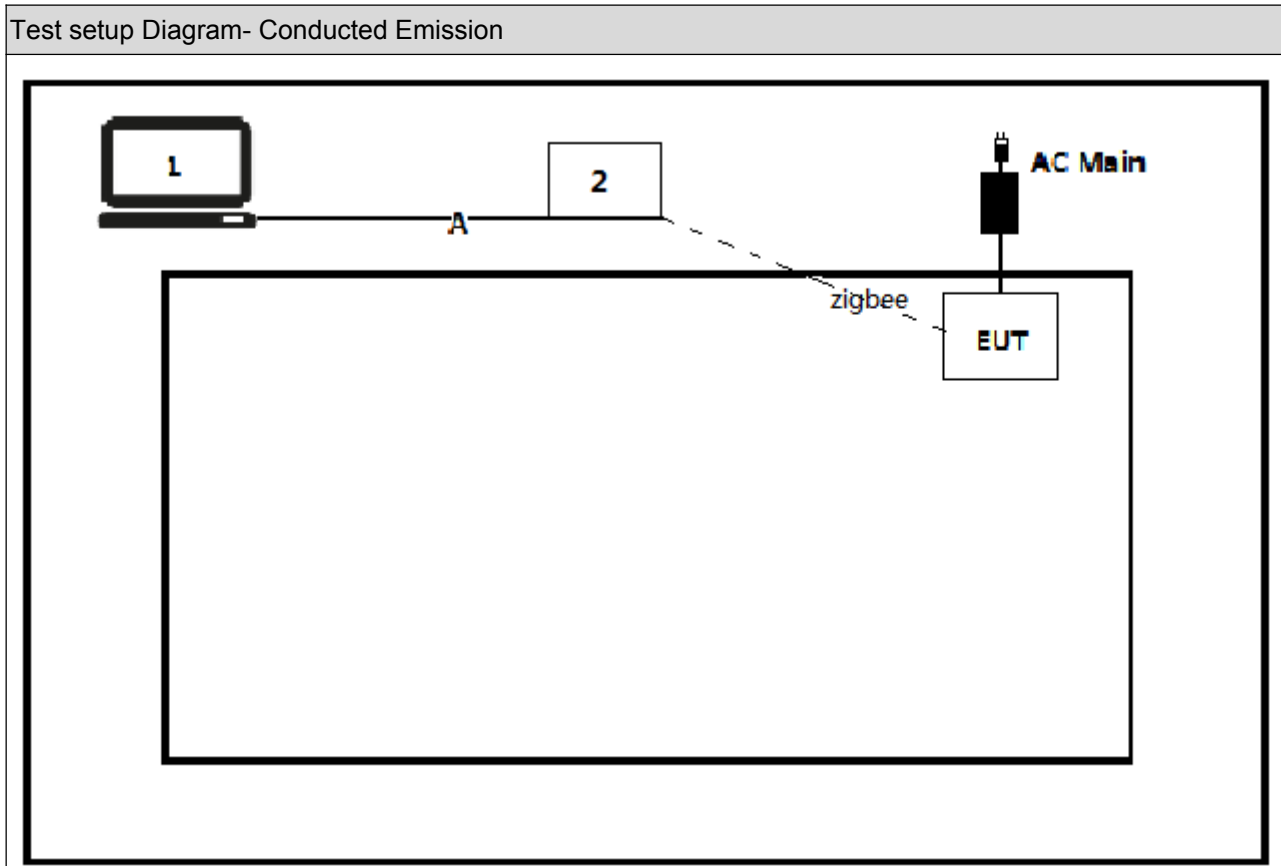

### 1.7. EUT Exercise Software

1	Setup the EUT and simulators as shown on above.
2	Turn on the power of equipment.
3	Run the test software[FCC Assist V2.4].
4	Select the transmission mode and test channel, then start test.

**2. Technical Test**

**2.1. Summary of Test Result**

**FCC:**

Performed Test Item	Normative References	Limit	Result
AC Power Line Conducted Emission	FCC CFR Title 47 Part 15 Subpart C Section 15.207	FCC 15.207	PASS
Emissions in restricted frequency bands	FCC CFR Title 47 Part 15 Subpart C Section 15.209	FCC 15.209	PASS
Emissions in non-restricted frequency bands	FCC CFR Title 47 Part 15 Subpart C Section 15.247(d)	20dBc	PASS
Radiated Emission Band Edge	FCC CFR Title 47 Part 15 Subpart C 15.247(d)	FCC 15.209	PASS
Occupied Bandwidth	FCC CFR Title 47 Part 15 Subpart C Section 15.247(a)(2)	500kHz	PASS
Fundamental emission output power	FCC CFR Title 47 Part 15 Subpart C Section 15.247(b)(3)	30dBm	PASS
Power Spectral Density	FCC CFR Title 47 Part 15 Subpart C Section 15.247(e)	8dBm/3kHz	PASS
Antenna Requirement	FCC CFR Title 47 Part 15 Subpart C Section 15.203	FCC 15.203	PASS

**ISED:**

Performed Test Item	Normative References	Limit	Result
AC Power Line Conducted Emission	RSS-Gen Issue 4 Section 8.8	RSS-Gen	PASS
Emissions in restricted frequency bands	RSS-Gen Issue 4 Section 8.9	RSS-Gen	PASS
Emissions in non-restricted frequency bands	RSS-247 Issue 2 Section A5.5	20dBc	PASS
Radiated Emission Band Edge	RSS-247 Issue 2 Section A5.5	RSS-247	PASS
Occupied Bandwidth	RSS-Gen Issue 4 Section 6.6 RSS-247 Issue 2 Section A5.2(1)	500kHz	PASS
Fundamental emission output power	RSS-247 Issue 2 Section A5.4(4)	30dBm	PASS
Power Spectral Density	RSS-247 Issue 2 Section A5.2(2)	8dBm/3kHz	PASS
Antenna Requirement	RSS-Gen Issue 4 Section 8.3	RSS-Gen Issue 4	PASS

## 2.2. Test Environment

Items	Required (IEC 68-1)	Actual
Temperature (°C)	15-35	21
Humidity (%RH)	25-75	50
Barometric pressure (mbar)	860-1060	950-1000

## 2.3. Measurement Uncertainty

Test Items	Uncertainty
AC Power Line Conducted Emission	$\pm 2.02\text{dB}$
Radiated Emission	Below 1GHz $\pm 3.8\text{ dB}$
	Above 1GHz $\pm 3.9\text{ dB}$
RF Antenna Port Conducted Emission	$\pm 1.27\text{dB}$
Radiated Emission Band Edge	$\pm 3.9\text{dB}$
Occupied Bandwidth	$\pm 1\text{kHz}$
Power Spectral Density	$\pm 1.27\text{dB}$

### 3. AC Power Line Conducted Emission

#### 3.1. Test Equipment

AC Power Line Conducted Emission / TR-1				
Instrument	Manufacturer	Type No.	Serial No.	Cal. Due Date
EMI Test Receiver	R&S	ESCI	100906	2019.03.04
Two-Line V-Network	R&S	ENV 216	101189	2019.07.15
Two-Line V-Network	R&S	ENV 216	101044	2019.09.15
50ohm Coaxial Switch	Anritsu	MP59B	6200464462	N/A
50ohm Termination	SHX	TF2	07081402	2019.09.15
Temperature/Humidity Meter	Zhichen	ZC1-2	TR1-TH	2019.01.03

Note: All equipment are calibrated with traceable calibrations. Each calibration is traceable to the national or international standards.

#### 3.2. Test Setup

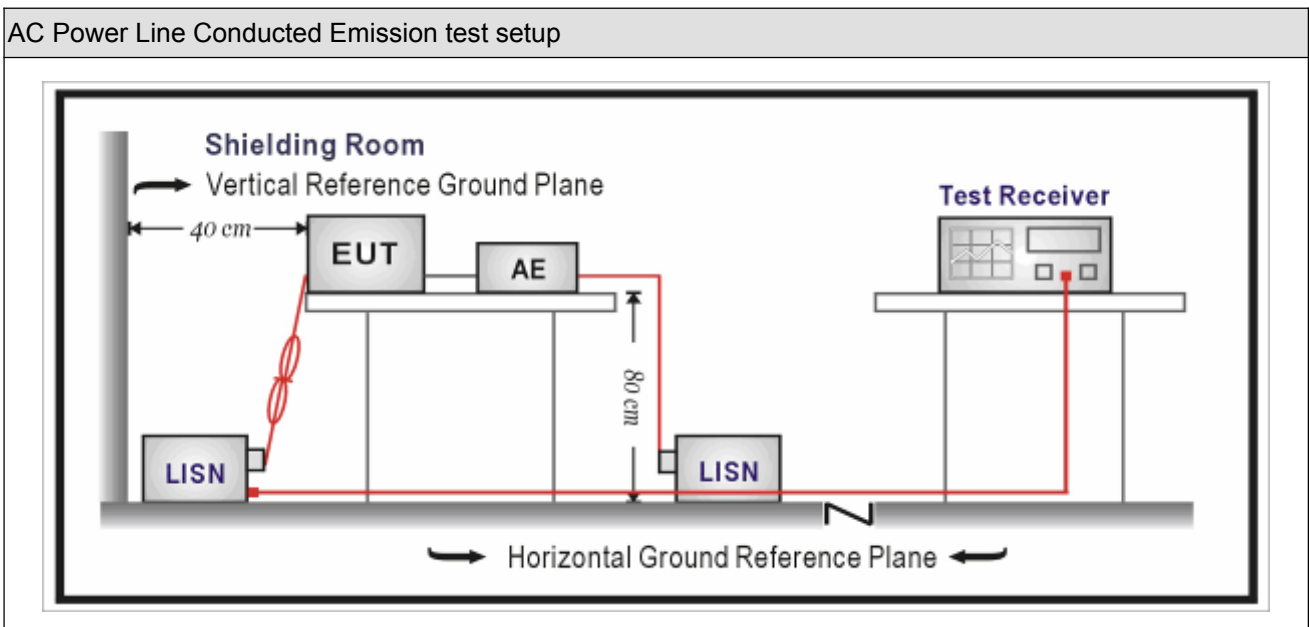

### 3.3. Limit

Frequency of Emission (MHz)	Conducted Limit	
	Quasi-peak (dB $\mu$ V)	Average(dB $\mu$ V)
0.15-0.5	66 to 56	56 to 46
0.5-5	56	46
5-30	60	50

Note 1: The lower limit shall apply at the transition frequencies.  
 Note 2: The limit decreases linearly with the logarithm of the frequency in the range 0.15 MHz to 0.5 MHz.

### 3.4. Test Procedure

Test Method			
	References Rule	Chapter	Item
<input checked="" type="checkbox"/>	ANSI C63.10-2013	6.2	Standard test method for ac power-line conducted emissions from unlicensed wireless devices
<input checked="" type="checkbox"/>	ANSI C63.4-2014	7	AC power-line conducted emission measurements

### 3.5. Test Result

Engineer: LEon	
Site: TR1	Time: 2018/11/15
Limit: FCC_Part15.207_CE_AC Power	Margin: 0
Probe: ENV216_101190(0.009-30MHz)	Polarity: Line
EUT: LED lamp(Crystal oscillator: Diode (FL3840023)_2017; Lighting source: APT)	Power: AC 120V/60Hz
Note: Mode1: Transmit at 2405MHz by Zigbee	

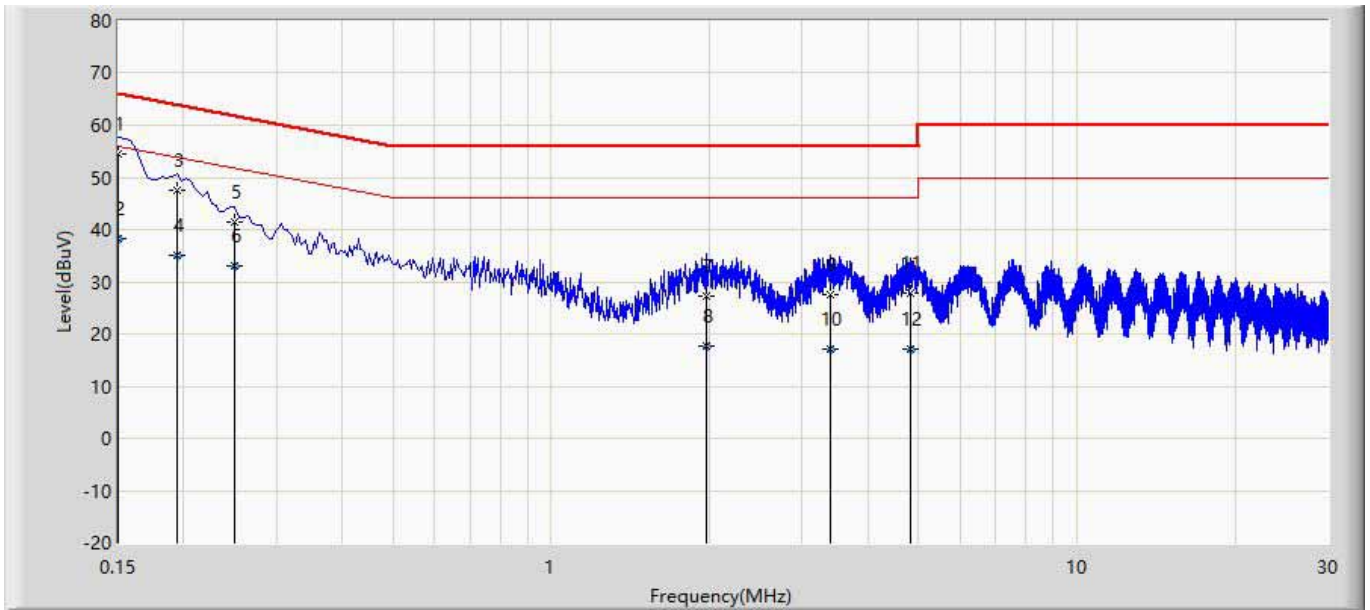

No	Mark	Frequency (MHz)	Measure Level (dBuV)	Reading Level (dBuV)	Over Limit (dB)	Limit (dBuV)	Probe (dB)	Cable (dB)	Amp (dB)	Type
1	*	0.150	54.362	44.732	-11.638	66.000	9.610	0.020	0.000	QP
2		0.150	38.140	28.510	-17.860	56.000	9.610	0.020	0.000	AV
3		0.194	47.558	37.927	-17.185	64.743	9.602	0.030	0.000	QP
4		0.194	34.971	25.340	-19.772	54.743	9.602	0.030	0.000	AV
5		0.250	41.579	31.948	-21.564	63.143	9.600	0.031	0.000	QP
6		0.250	33.118	23.487	-20.025	53.143	9.600	0.031	0.000	AV
7		1.970	27.367	17.667	-28.633	56.000	9.610	0.090	0.000	QP
8		1.970	17.790	8.090	-28.210	46.000	9.610	0.090	0.000	AV
9		3.390	27.443	17.702	-28.557	56.000	9.633	0.108	0.000	QP
10		3.390	17.097	7.356	-28.903	46.000	9.633	0.108	0.000	AV
11		4.830	27.690	17.891	-28.310	56.000	9.657	0.142	0.000	QP
12		4.830	17.034	7.235	-28.966	46.000	9.657	0.142	0.000	AV

Note:

1. " \* ", means this data is the worst emission level.
2. Measurement Level = Reading Level + Factor(Probe+Cable-Amp).



Engineer: LEon	
Site: TR1	Time: 2018/11/15
Limit: FCC_Part15.207_CE_AC Power	Margin: 0
Probe: ENV216_101190(0.009-30MHz)	Polarity: Neutral
EUT: LED lamp(Crystal oscillator: Diode (FL3840023)_2017; Lighting source: APT)	Power: AC 120V/60Hz
Note: Mode1: Transmit at 2405MHz by Zigbee	

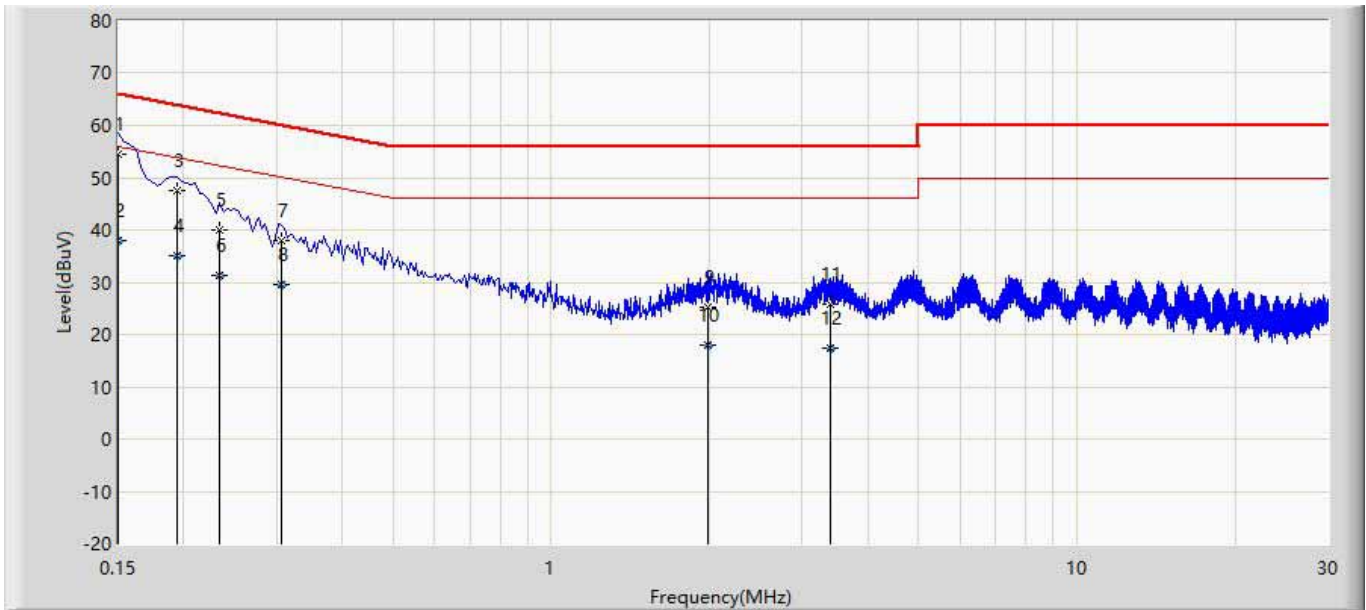

No	Mark	Frequency (MHz)	Measure Level (dBuV)	Reading Level (dBuV)	Over Limit (dB)	Limit (dBuV)	Probe (dB)	Cable (dB)	Amp (dB)	Type
1	*	0.150	54.368	44.754	-11.632	66.000	9.594	0.020	0.000	QP
2		0.150	38.086	28.472	-17.914	56.000	9.594	0.020	0.000	AV
3		0.194	47.569	37.941	-17.174	64.743	9.598	0.030	0.000	QP
4		0.194	35.033	25.405	-19.710	54.743	9.598	0.030	0.000	AV
5		0.234	40.040	30.411	-23.560	63.600	9.598	0.031	0.000	QP
6		0.234	31.240	21.610	-22.360	53.600	9.598	0.031	0.000	AV
7		0.306	38.100	28.474	-23.443	61.543	9.596	0.029	0.000	QP
8		0.306	29.628	20.002	-21.915	51.543	9.596	0.029	0.000	AV
9		1.990	25.297	15.590	-30.703	56.000	9.610	0.096	0.000	QP
10		1.990	17.860	8.154	-28.140	46.000	9.610	0.096	0.000	AV
11		3.402	25.740	16.004	-30.260	56.000	9.629	0.107	0.000	QP
12		3.402	17.399	7.663	-28.601	46.000	9.629	0.107	0.000	AV

Note:

1. " \* ", means this data is the worst emission level.
2. Measurement Level = Reading Level + Factor(Probe+Cable-Amp).

Engineer: LEon	
Site: TR1	Time: 2018/11/15
Limit: FCC_Part15.207_CE_AC Power	Margin: 0
Probe: ENV216_101190(0.009-30MHz)	Polarity: Line
EUT: LED lamp(Crystal oscillator: Diode (FL3840023)_2017; Lighting source: LTN)	Power: AC 120V/60Hz
Note: Mode1: Transmit at 2405MHz by Zigbee	

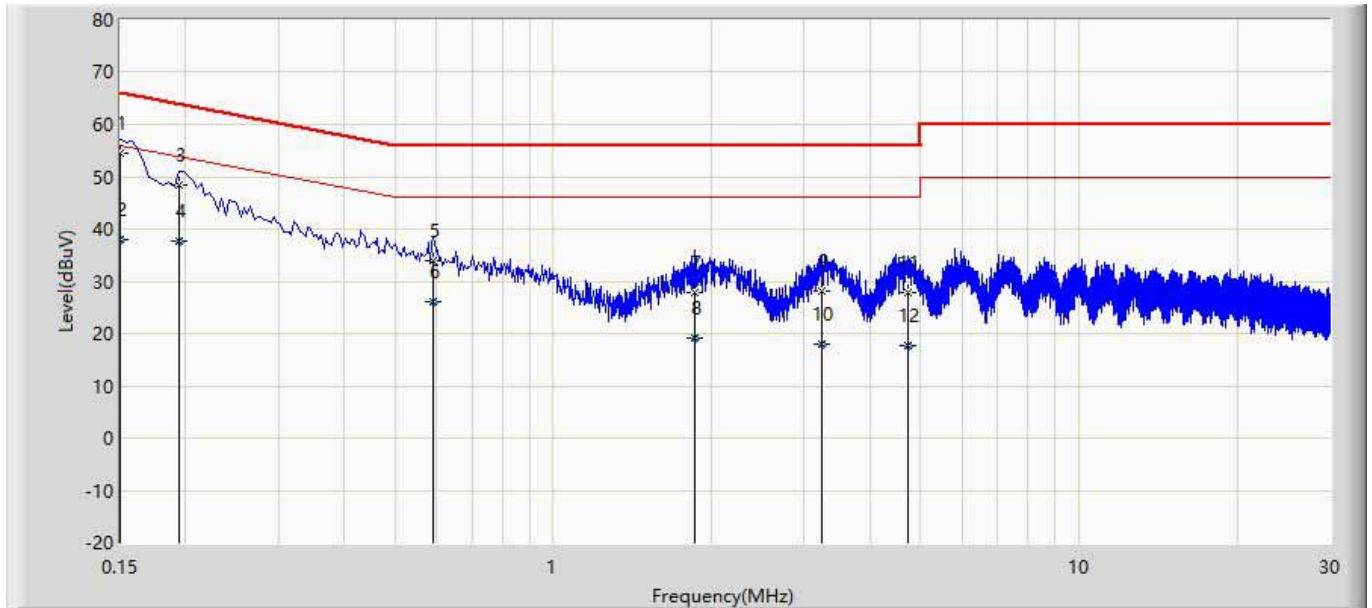

No	Mark	Frequency (MHz)	Measure Level (dBuV)	Reading Level (dBuV)	Over Limit (dB)	Limit (dBuV)	Probe (dB)	Cable (dB)	Amp (dB)	Type
1	*	0.150	54.543	44.913	-11.457	66.000	9.610	0.020	0.000	QP
2		0.150	38.023	28.393	-17.977	56.000	9.610	0.020	0.000	AV
3		0.194	48.292	38.660	-16.451	64.743	9.602	0.030	0.000	QP
4		0.194	37.562	27.930	-17.181	54.743	9.602	0.030	0.000	AV
5		0.590	33.865	24.220	-22.135	56.000	9.600	0.044	0.000	QP
6		0.590	26.083	16.439	-19.917	46.000	9.600	0.044	0.000	AV
7		1.862	27.701	18.015	-28.299	56.000	9.610	0.076	0.000	QP
8		1.862	18.995	9.309	-27.005	46.000	9.610	0.076	0.000	AV
9		3.242	28.148	18.403	-27.852	56.000	9.631	0.114	0.000	QP
10		3.242	18.085	8.341	-27.915	46.000	9.631	0.114	0.000	AV
11		4.738	27.748	17.957	-28.252	56.000	9.656	0.135	0.000	QP
12		4.738	17.688	7.897	-28.312	46.000	9.656	0.135	0.000	AV

**Note:**

1. " \* ", means this data is the worst emission level.
2. Measurement Level = Reading Level + Factor(Probe+Cable-Amp).

Engineer: LEon	
Site: TR1	Time: 2018/11/15
Limit: FCC_Part15.207_CE_AC Power	Margin: 0
Probe: ENV216_101190(0.009-30MHz)	Polarity: Neutral
EUT: LED lamp(Crystal oscillator: Diode (FL3840023)_2017; Lighting source: LTN)	Power: AC 120V/60Hz
Note: Mode1: Transmit at 2405MHz by Zigbee	

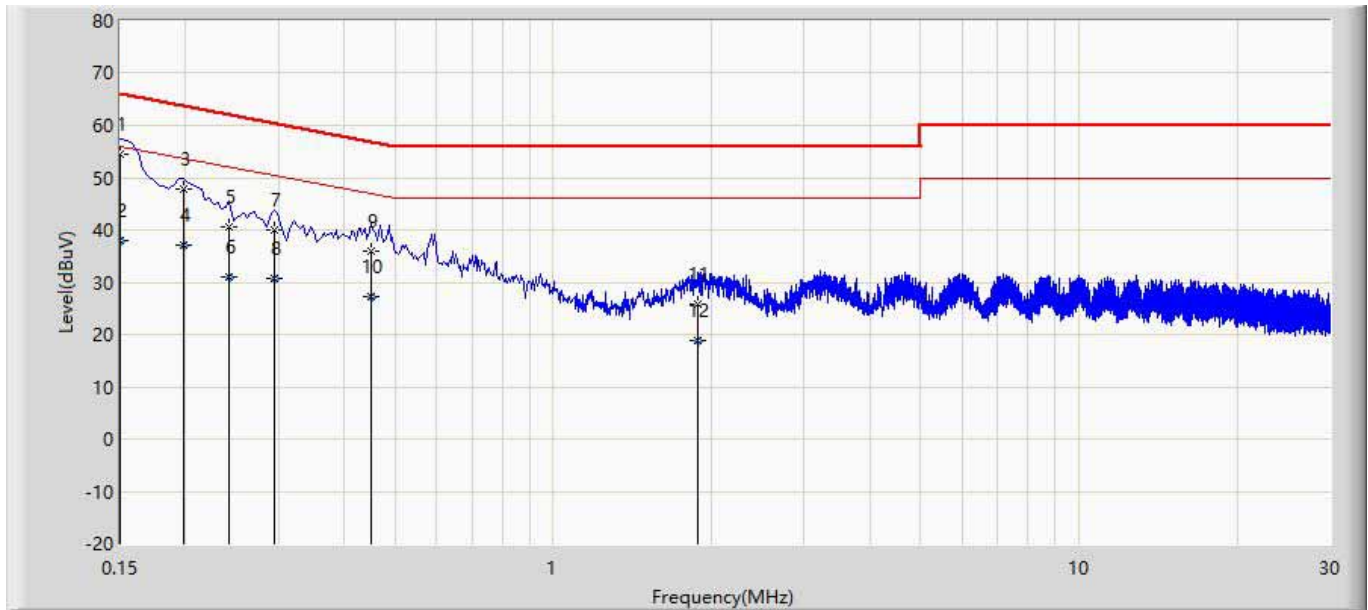

No	Mark	Frequency (MHz)	Measure Level (dBuV)	Reading Level (dBuV)	Over Limit (dB)	Limit (dBuV)	Probe (dB)	Cable (dB)	Amp (dB)	Type
1	*	0.150	54.532	44.918	-11.468	66.000	9.594	0.020	0.000	QP
2		0.150	37.966	28.352	-18.034	56.000	9.594	0.020	0.000	AV
3		0.198	47.937	38.308	-16.692	64.629	9.598	0.030	0.000	QP
4		0.198	37.197	27.568	-17.432	54.629	9.598	0.030	0.000	AV
5		0.242	40.462	30.833	-22.909	63.371	9.598	0.031	0.000	QP
6		0.242	30.956	21.327	-22.415	53.371	9.598	0.031	0.000	AV
7		0.294	39.994	30.365	-21.891	61.886	9.596	0.033	0.000	QP
8		0.294	30.732	21.102	-21.154	51.886	9.596	0.033	0.000	AV
9		0.450	36.050	26.411	-21.378	57.429	9.591	0.048	0.000	QP
10		0.450	27.324	17.685	-20.105	47.429	9.591	0.048	0.000	AV
11		1.882	25.931	16.241	-30.069	56.000	9.607	0.082	0.000	QP
12		1.882	18.750	9.060	-27.250	46.000	9.607	0.082	0.000	AV

Note:

1. " \* ", means this data is the worst emission level.
2. Measurement Level = Reading Level + Factor(Probe+Cable-Amp).

Engineer: LEon	
Site: TR1	Time: 2018/11/15
Limit: FCC_Part15.207_CE_AC Power	Margin: 0
Probe: ENV216_101190(0.009-30MHz)	Polarity: Line
EUT: LED lamp(Crystal oscillator: Murata(XRCGB38M400FXH17R0))	Power: AC 120V/60Hz
Note: Mode1: Transmit at 2405MHz by Zigbee	

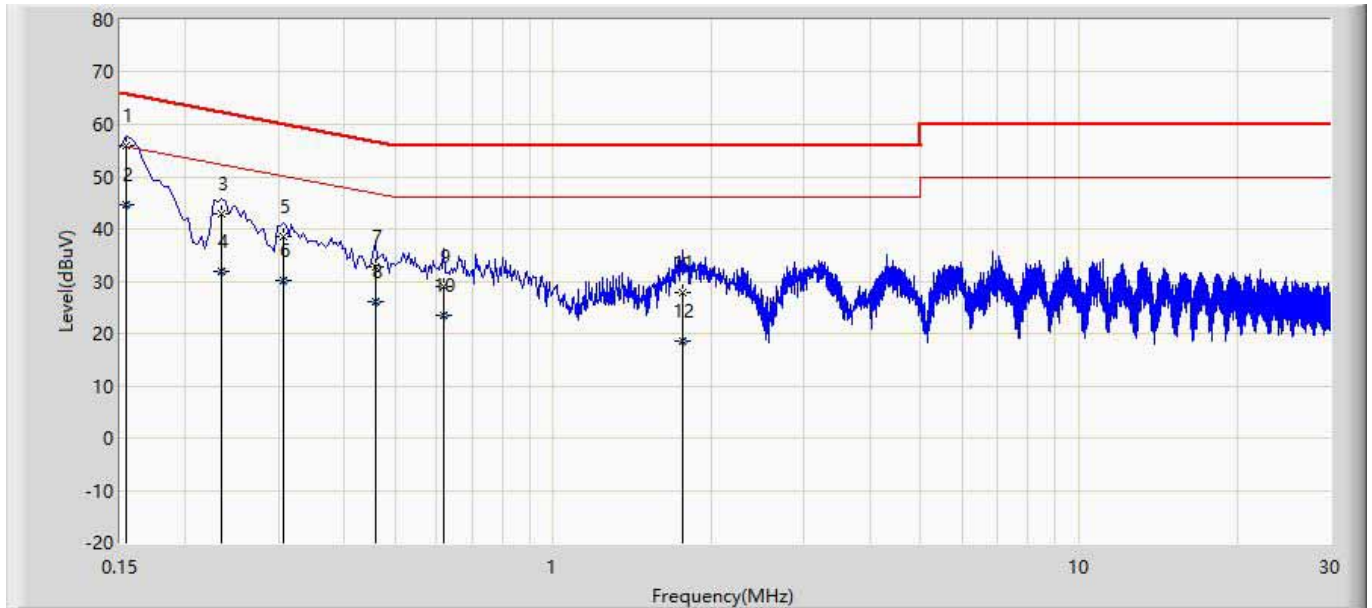

No	Mark	Frequency (MHz)	Measure Level (dBuV)	Reading Level (dBuV)	Over Limit (dB)	Limit (dBuV)	Probe (dB)	Cable (dB)	Amp (dB)	Type
1	*	0.154	56.060	46.430	-9.825	65.886	9.609	0.021	0.000	QP
2		0.154	44.508	34.877	-11.378	55.886	9.609	0.021	0.000	AV
3		0.234	42.794	33.163	-20.806	63.600	9.600	0.031	0.000	QP
4		0.234	32.022	22.391	-21.578	53.600	9.600	0.031	0.000	AV
5		0.306	38.515	28.886	-23.028	61.543	9.600	0.029	0.000	QP
6		0.306	30.114	20.484	-21.429	51.543	9.600	0.029	0.000	AV
7		0.458	32.681	23.027	-24.519	57.200	9.600	0.053	0.000	QP
8		0.458	26.079	16.426	-21.121	47.200	9.600	0.053	0.000	AV
9		0.618	28.889	19.243	-27.111	56.000	9.600	0.046	0.000	QP
10		0.618	23.338	13.692	-22.662	46.000	9.600	0.046	0.000	AV
11		1.758	27.900	18.216	-28.100	56.000	9.610	0.074	0.000	QP
12		1.758	18.657	8.973	-27.343	46.000	9.610	0.074	0.000	AV

**Note:**

1. " \* ", means this data is the worst emission level.
2. Measurement Level = Reading Level + Factor(Probe+Cable-Amp).

Engineer: Leon	
Site: TR1	Time: 2018/11/15
Limit: FCC_Part15.207_CE_AC Power	Margin: 0
Probe: ENV216_101190(0.009-30MHz)	Polarity: Neutral
EUT: LED lamp(Crystal oscillator: Murata(XRCGB38M400FXH17R0))	Power: AC 120V/60Hz
Note: Mode1: Transmit at 2405MHz by Zigbee	

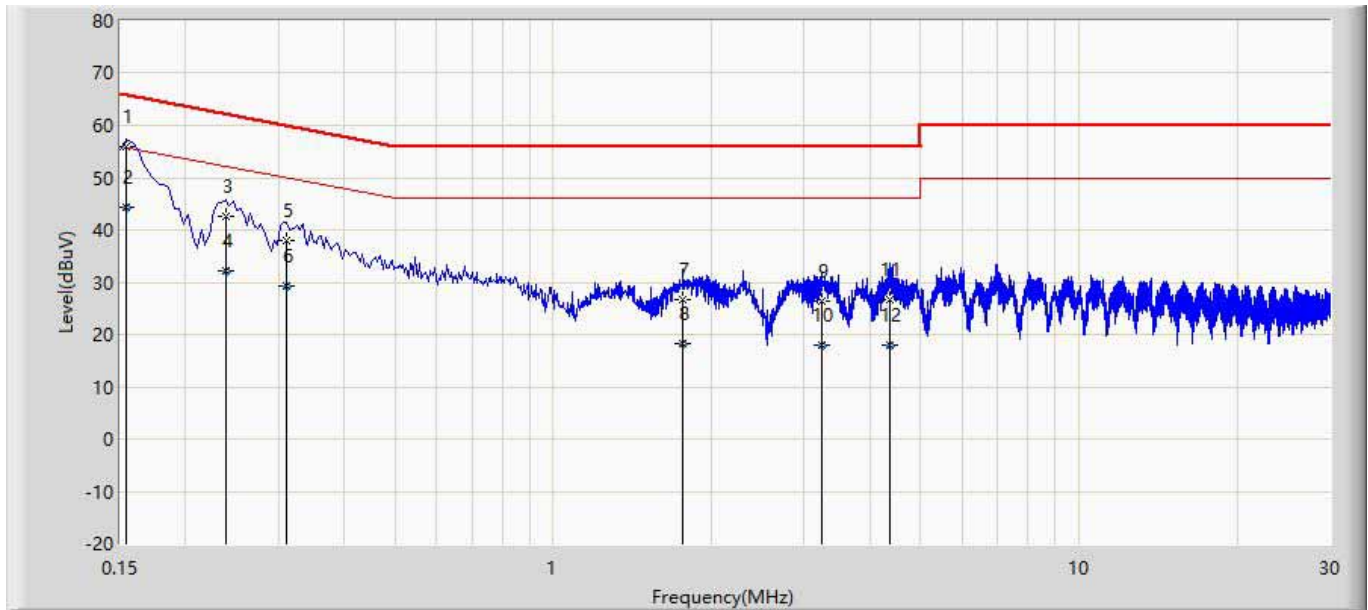

No	Mark	Frequency (MHz)	Measure Level (dBuV)	Reading Level (dBuV)	Over Limit (dB)	Limit (dBuV)	Probe (dB)	Cable (dB)	Amp (dB)	Type
1	*	0.154	56.054	46.440	-9.832	65.886	9.593	0.021	0.000	QP
2		0.154	44.423	34.809	-11.463	55.886	9.593	0.021	0.000	AV
3		0.238	42.606	32.976	-20.880	63.486	9.598	0.031	0.000	QP
4		0.238	32.292	22.663	-21.194	53.486	9.598	0.031	0.000	AV
5		0.310	37.849	28.224	-23.580	61.429	9.596	0.029	0.000	QP
6		0.310	29.303	19.678	-22.126	51.429	9.596	0.029	0.000	AV
7		1.762	26.759	17.079	-29.241	56.000	9.605	0.074	0.000	QP
8		1.762	18.404	8.724	-27.596	46.000	9.605	0.074	0.000	AV
9		3.238	26.273	16.533	-29.727	56.000	9.627	0.113	0.000	QP
10		3.238	17.967	8.227	-28.033	46.000	9.627	0.113	0.000	AV
11		4.362	26.681	16.923	-29.319	56.000	9.641	0.117	0.000	QP
12		4.362	17.998	8.241	-28.002	46.000	9.641	0.117	0.000	AV

Note:

1. " \* ", means this data is the worst emission level.
2. Measurement Level = Reading Level + Factor(Probe+Cable-Amp).

## 4. Emissions in restricted frequency bands

### 4.1. Test Equipment

Radiated Emission(Below 1GHz) / AC-2				
Instrument	Manufacturer	Type No.	Serial No.	Cal. Due Date
EMI Test Receiver	R&S	ESCI	100573	2019.03.28
Loop Antenna	R&S	HFH2-Z2	833799/003	2019.11.15
Bilog Antenna	Teseq GmbH	CBL6112D	27611	2019.10.15
Coaxial Cable	Huber+Suhner	SUCOFLEX 106	AC2-C	2019.03.01
Temperature/Humidity Meter	Zhichen	ZC1-2	AC2-TH	2019.01.02
Note: All equipment are calibrated with traceable calibrations. Each calibration is traceable to the national or international standards.				

Radiated Emission(Above 1GHz) / AC-5				
Instrument	Manufacturer	Type No.	Serial No.	Cal. Due Date
Spectrum Analyzer	Agilent	E4446A	MY45300103	2019.01.03
Preamplifier	Miteq	NSP1800-25	1364185	2019.05.05
Preamplifier	QuieTek	AP-040G	CHM-0906001	2019.05.05
DRG Horn	ETS-Lindgren	3117	00123988	2019.01.21
Broad-Band Horn Antenna	Schwarzbeck	BBHA9170	294	2018.11.24
Coaxial Cable	Huber+Suhner	SUCOFLEX 106	AC5-C1	2019.03.01
Coaxial Cable	Huber+Suhner	SUCOFLEX 106	AC5-C2	2019.03.01
Coaxial Cable	Huber+Suhner	SUCOFLEX 102	AC5-C3	2019.03.01
EMI Receiver	Agilent	N9038A	MY51210196	2019.06.09
Temperature/Humidity Meter	Zhichen	ZC1-2	AC5-TH	2019.01.03
Note: All equipment are calibrated with traceable calibrations. Each calibration is traceable to the national or international standards.				

### 4.2. Test Setup

Below 30MHz Test Setup:

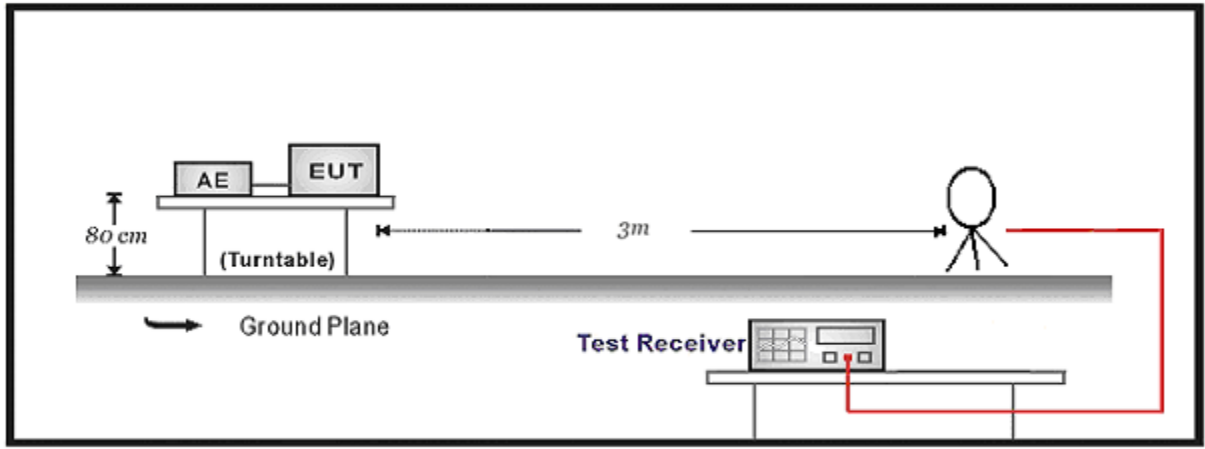

30MHz-1GHz Test Setup:

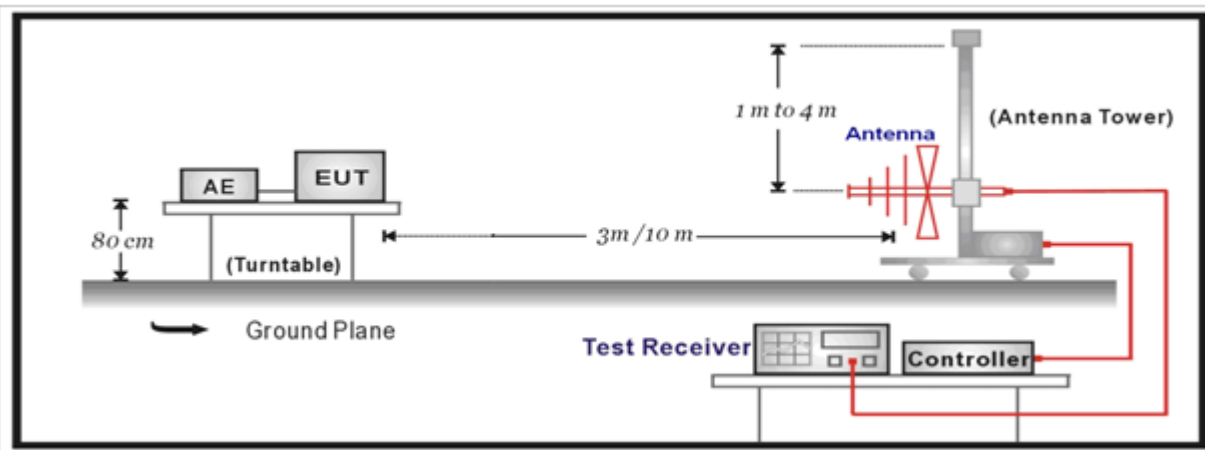

Above 1GHz Test Setup:

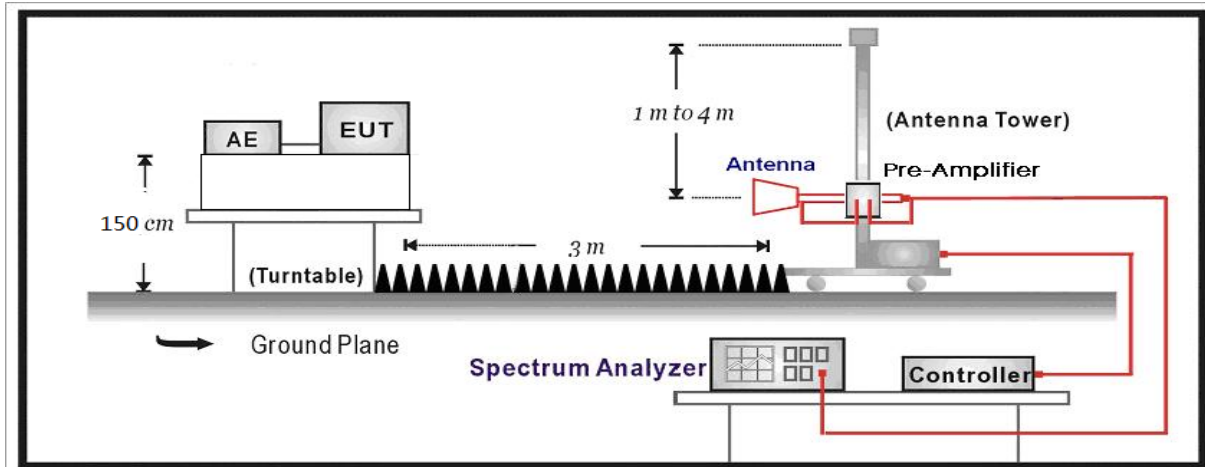

**4.3. Limit**

**For FCC:**

Restricted Bands of operation			
Frequency (MHz)	Frequency (MHz)	Frequency (MHz)	Frequency (GHz)
0.090 – 0.110	16.42 – 16.423	399.9 – 410	4.5 – 5.15
0.495 – 0.505	16.69475 – 16.69525	608 – 614	5.35 – 5.46
2.1735 – 2.1905	16.80425 – 16.80475	960 – 1240	7.25 – 7.75
4.125 – 4.128	25.5 – 25.67	1300 – 1427	8.025 – 8.5
4.17725 – 4.17775	37.5 – 38.25	1435 – 1626.5	9.0 – 9.2
4.20725 – 4.20775	73 – 74.6	1645.5 – 1646.5	9.3 – 9.5
6.215 – 6.218	74.8 – 75.2	1660 – 1710	10.6 – 12.7
6.26775 – 6.26825	108 – 121.94	1718.8 – 1722.2	13.25 – 13.4
6.31175 – 6.31225	123 – 138	2200 – 2300	14.47 – 14.5
8.291 – 8.294	149.9 – 150.05	2310 – 2390	15.35 – 16.2
8.362 – 8.366	156.52475 – 156.52525	2483.5 – 2500	17.7 – 21.4
8.37625 – 8.38675	156.7 – 156.9	2690 – 2900	22.01 – 23.12
8.81425 – 8.81475	162.0125 – 167.17	3260 – 3267	23.6 – 24.0
12.29 – 12.293	167.72 – 173.2	3332 – 3339	31.2 – 31.8
12.51975 – 12.52025	240 – 285	3345.8 – 3358	36.43 – 36.5
12.57675 – 12.57725	322 – 335.4	3600 – 4400	
13.36 – 13.41			



**For ISED:**

Restricted Bands of operation			
Frequency (MHz)	Frequency (MHz)	Frequency (MHz)	Frequency (GHz)
0.090-0.110	13.36-13.41	1645.5-1646.5	9.0-9.2
2.1735-2.1905	16.42-16.423	1660-1710	9.3-9.5
3.020-3.026	16.69475-16.69525	1718.8-1722.2	10.6-12.7
4.125-4.128	16.80425-16.80475	2200-2300	13.25-13.4
4.17725-4.17775	25.5-25.67	2310-2390	14.47-14.5
4.20725-4.20775	37.5-38.25	2655-2900	15.35-16.2
5.677-5.683	73-74.6	3260-3267	17.7-21.4
6.215-6.218	74.8-75.2	3332-3339	22.01-23.12
6.26775-6.26825	108-138	3345.8-3358	23.6-24.0
6.31175-6.31225	156.52475-156.52525	3500-4400	31.2-31.8
8.291-8.294	156.7-156.9	4500-5150	36.43-36.5
8.362-8.366	240-285	5350-5460	Above 38.6
8.37625-8.38675	322-335.4	7250-7750	
8.41425-8.41475	399.9-410	8025-8500	
12.29-12.293	608-614		
12.51975-12.52025	960-1427		
12.57675-12.57725	1435-1626.5		

Restricted Band Emissions Limit			
Frequency (MHz)	Field strength ( $\mu$ V/m)	Field strength (dB $\mu$ V/m)	Measurement distance (m)
0.009 - 0.49	2400/F(kHz)	48.5 – 13.8	30 <sub>(Note 1)</sub>
0.49 - 1.705	24000/F(kHz)	33.8 - 23	30 <sub>(Note 1)</sub>
1.705 - 30	30	29.5	30 <sub>(Note 1)</sub>
30 - 88	100	40	3 <sub>(Note 2)</sub>
88 - 216	150	43.5	3 <sub>(Note 2)</sub>
216 - 960	200	46	3 <sub>(Note 2)</sub>
Above 960	500	54	3 <sub>(Note 2)</sub>



Note 1: At frequencies below 30 MHz, measurements may be performed at a distance closer than that specified in the regulations; however, an attempt should be made to avoid making measurements in the near field. Pending the development of an appropriate measurement procedure for measurements performed below 30 MHz, when performing measurements at a closer distance than specified, the results shall be extrapolated to the specified distance by either making measurements at a minimum of two distances on at least one radial to determine the proper extrapolation factor or by using the square of an inverse linear distance extrapolation factor (40 dB/decade).

Note 2: At frequencies at or above 30 MHz, measurements may be performed at a distance other than what is specified provided: measurements are not made in the near field except where it can be shown that near field measurements are appropriate due to the characteristics of the device; and it can be demonstrated that the signal levels needed to be measured at the distance employed can be detected by the measurement equipment. Measurements shall not be performed at a distance greater than 30 meters unless it can be further demonstrated that measurements at a distance of 30 meters or less are impractical. When performing measurements at a distance other than that specified, the results shall be extrapolated to the specified distance using an extrapolation factor of 20 dB/decade (inverse linear-distance for field strength measurements; inverse-linear-distance-squared for power density measurements).

#### 4.4. Test Procedure

Test Method			
	References Rule	Chapter	Description
<input type="checkbox"/>	ANSI C63.10	11.11	Emissions in non-restricted frequency bands
	<input type="checkbox"/> ANSI C63.10	11.11.2	Reference level measurement
	<input type="checkbox"/> ANSI C63.10	11.11.3	Emission level measurement
<input checked="" type="checkbox"/>	ANSI C63.10	11.12	Emissions in restricted frequency bands
	<input checked="" type="checkbox"/> ANSI C63.10	11.12.1	Radiated emission measurements
	<input checked="" type="checkbox"/> ANSI C63.10	11.12.2.7	Radiated spurious emission test
	<input checked="" type="checkbox"/> ANSI C63.10	6.4	Radiated emissions from unlicensed wireless devices below 30 MHz
	<input checked="" type="checkbox"/> ANSI C63.10	6.5	Radiated emissions from unlicensed wireless devices in the frequency range of 30 MHz to 1000 MHz
	<input checked="" type="checkbox"/> ANSI C63.10	6.6	Radiated emissions from unlicensed wireless devices above 1 GHz
	<input type="checkbox"/> ANSI C63.10	11.12.2.3	Quasi-peak measurement procedure
	<input checked="" type="checkbox"/> ANSI C63.10	11.12.2.4	Peak power measurement procedure
	<input checked="" type="checkbox"/> ANSI C63.10	11.12.2.5	Average power measurement procedures
	<input type="checkbox"/> ANSI C63.10	11.12.2.5.1	Trace averaging with continuous EUT transmission at full power
	<input type="checkbox"/> ANSI C63.10	11.12.2.5.2	Trace averaging across ON and OFF times of the EUT transmissions followed by duty cycle correction
	<input checked="" type="checkbox"/> ANSI C63.10	11.12.2.5.3	Reduced VBW averaging across ON and OFF times of the EUT transmissions with max hold

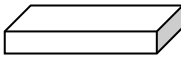
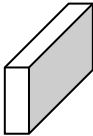
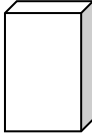
**4.5. EUT test Axis definition**

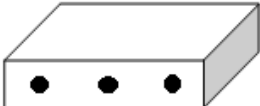
Item	Emissions in restricted frequency bands			
Device Category	<input type="checkbox"/>	Fixed point-to-point		
	<input type="checkbox"/>	Emit multiple directional beams, simultaneously or sequentially		
	<input checked="" type="checkbox"/>	Other cases		
Test mode	Mode 1			
Test method	<input checked="" type="checkbox"/>	Radiated		
		X Axis	Y Axis	Z Axis
				
		Worst Axis <input checked="" type="checkbox"/>	Worst Axis <input type="checkbox"/>	Worst Axis <input type="checkbox"/>
	<input type="checkbox"/>	Conducted		
	<input type="checkbox"/>	Chain 0		
				
	<input type="checkbox"/>	Chain 0	Chain 1	
				
	<input type="checkbox"/>	Chain 0	Chain 1	Chain 2
				

### 4.6. Test Result

**Hue White and Color/BR30 (Crystal oscillator: Diode (FL3840023)\_2017; Lighting source: LTN)**

Engineer: Karl	
Site: AC5	Time: 2018/11/08 - 00:37
Limit: FCC_Part15.209_RE(3m)	Margin: 0
Probe: Horn_3117_00167055(1-18GHz)	Polarity: Vertical
EUT: LED lamp	Power: AC 120V/60Hz
Note: Mode 1:Transmit at 2405MHz by Zigbee LTN	

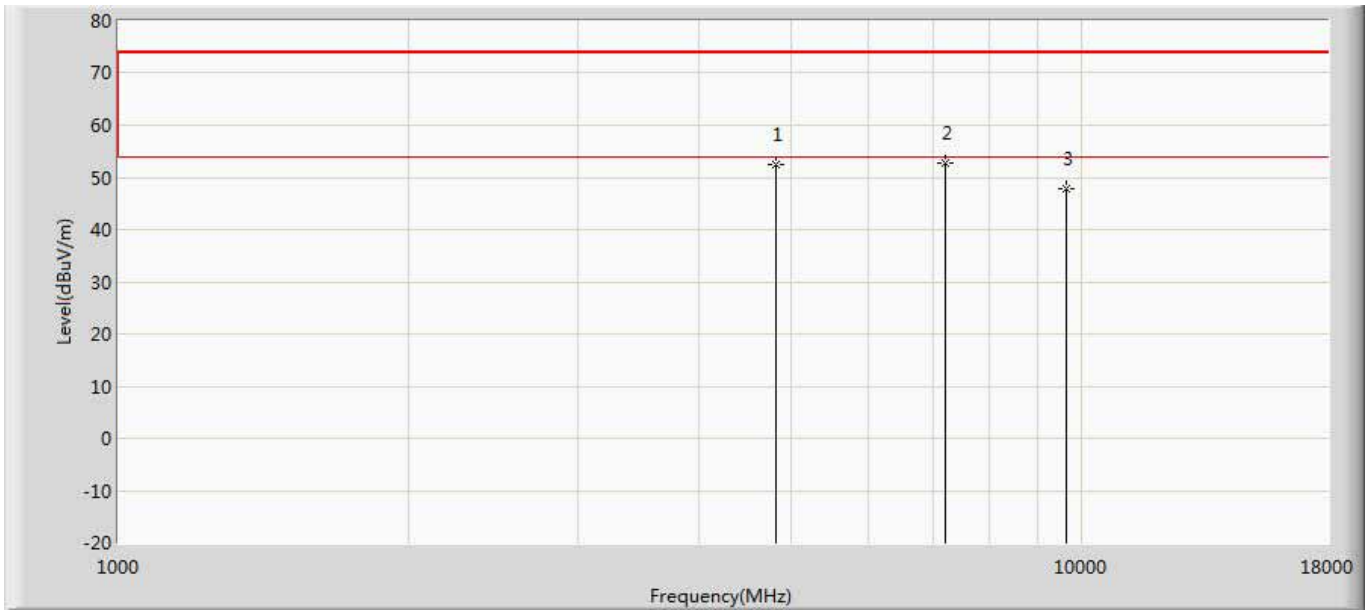

No	Mark	Frequency (MHz)	Measure Level (dBuV/m)	Reading Level (dBuV)	Over Limit (dB)	Limit (dBuV/m)	Factor (dB)	Type
1		4810.000	52.488	52.325	-21.512	74.000	0.162	PK
2	*	7215.000	52.726	49.254	-21.274	74.000	3.472	PK
3		9620.000	47.690	39.257	-26.310	74.000	8.433	PK

Engineer: Karl	
Site: AC5	Time: 2018/11/08 - 00:38
Limit: FCC_Part15.209_RE(3m)	Margin: 0
Probe: Horn_3117_00167055(1-18GHz)	Polarity: Horizontal
EUT: LED lamp	Power: AC 120V/60Hz
Note: Mode 1:Transmit at 2405MHz by Zigbee LTN	

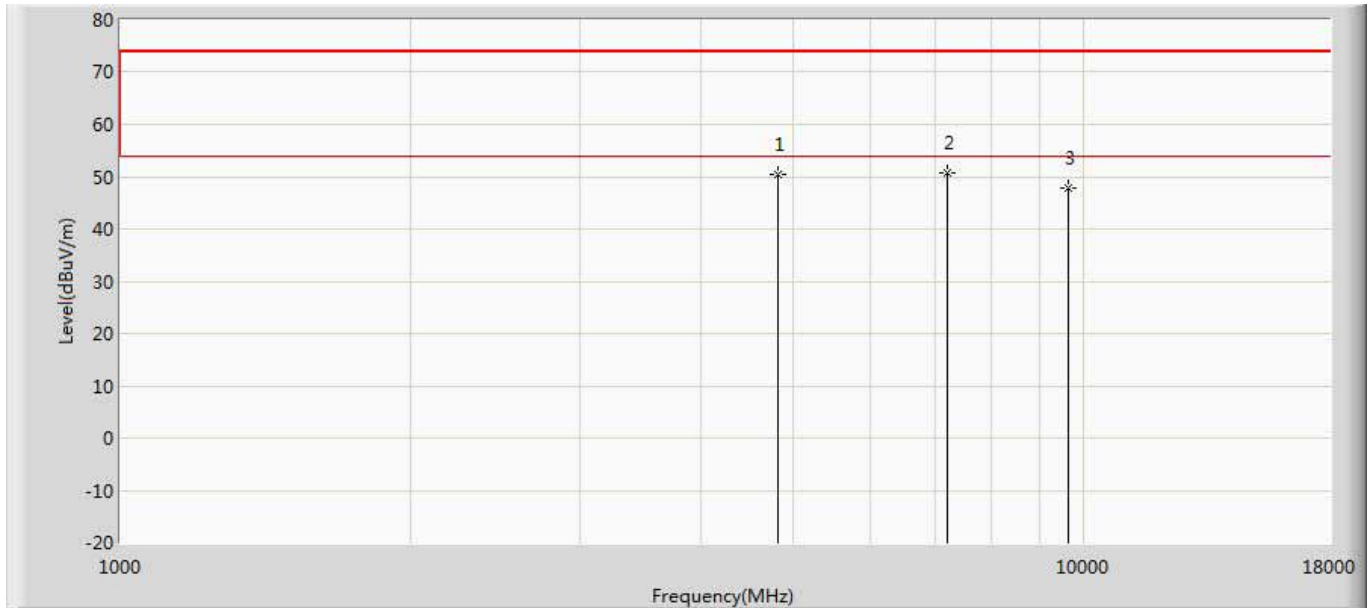

No	Mark	Frequency (MHz)	Measure Level (dBuV/m)	Reading Level (dBuV)	Over Limit (dB)	Limit (dBuV/m)	Factor (dB)	Type
1		4810.000	50.378	50.215	-23.622	74.000	0.162	PK
2	*	7215.000	50.832	47.360	-23.168	74.000	3.472	PK
3		9620.000	47.792	39.359	-26.208	74.000	8.433	PK

Engineer: Karl	
Site: AC5	Time: 2018/11/08 - 00:39
Limit: FCC_Part15.209_RE(3m)	Margin: 0
Probe: Horn_3117_00167055(1-18GHz)	Polarity: Vertical
EUT: LED lamp	Power: AC 120V/60Hz
Note: Mode 1:Transmit at 2450MHz by Zigbee LTN	

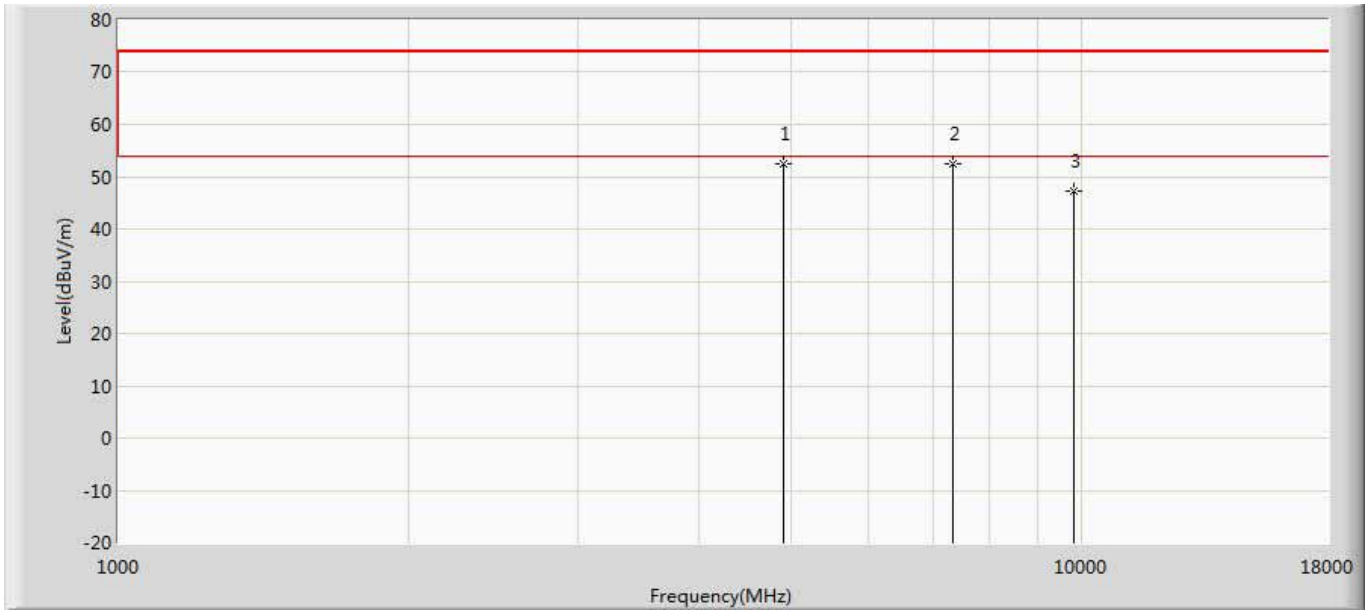

No	Mark	Frequency (MHz)	Measure Level (dBuV/m)	Reading Level (dBuV)	Over Limit (dB)	Limit (dBuV/m)	Factor (dB)	Type
1		4900.000	52.483	52.266	-21.517	74.000	0.216	PK
2	*	7350.000	52.551	48.359	-21.449	74.000	4.192	PK
3		9800.000	47.222	39.558	-26.778	74.000	7.664	PK

Engineer: Karl	
Site: AC5	Time: 2018/11/08 - 00:40
Limit: FCC_Part15.209_RE(3m)	Margin: 0
Probe: Horn_3117_00167055(1-18GHz)	Polarity: Horizontal
EUT: LED lamp	Power: AC 120V/60Hz
Note: Mode 1:Transmit at 2450MHz by Zigbee LTN	

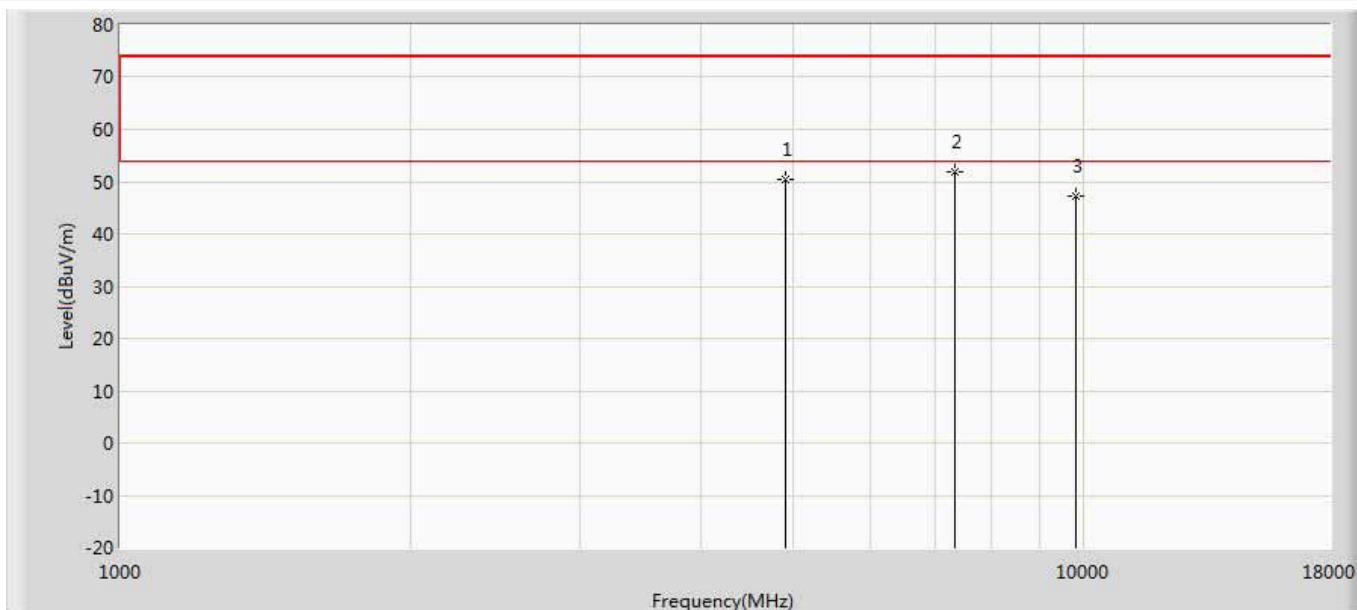

No	Mark	Frequency (MHz)	Measure Level (dBuV/m)	Reading Level (dBuV)	Over Limit (dB)	Limit (dBuV/m)	Factor (dB)	Type
1		4900.000	50.543	50.326	-23.457	74.000	0.216	PK
2	*	7350.000	51.740	47.548	-22.260	74.000	4.192	PK
3		9800.000	47.323	39.659	-26.677	74.000	7.664	PK



Engineer: Karl	
Site: AC5	Time: 2018/11/08 - 00:40
Limit: FCC_Part15.209_RE(3m)	Margin: 0
Probe: Horn_3117_00167055(1-18GHz)	Polarity: Vertical
EUT: LED lamp	Power: AC 120V/60Hz
Note: Mode 1:Transmit at 2480MHz by Zigbee LTN	

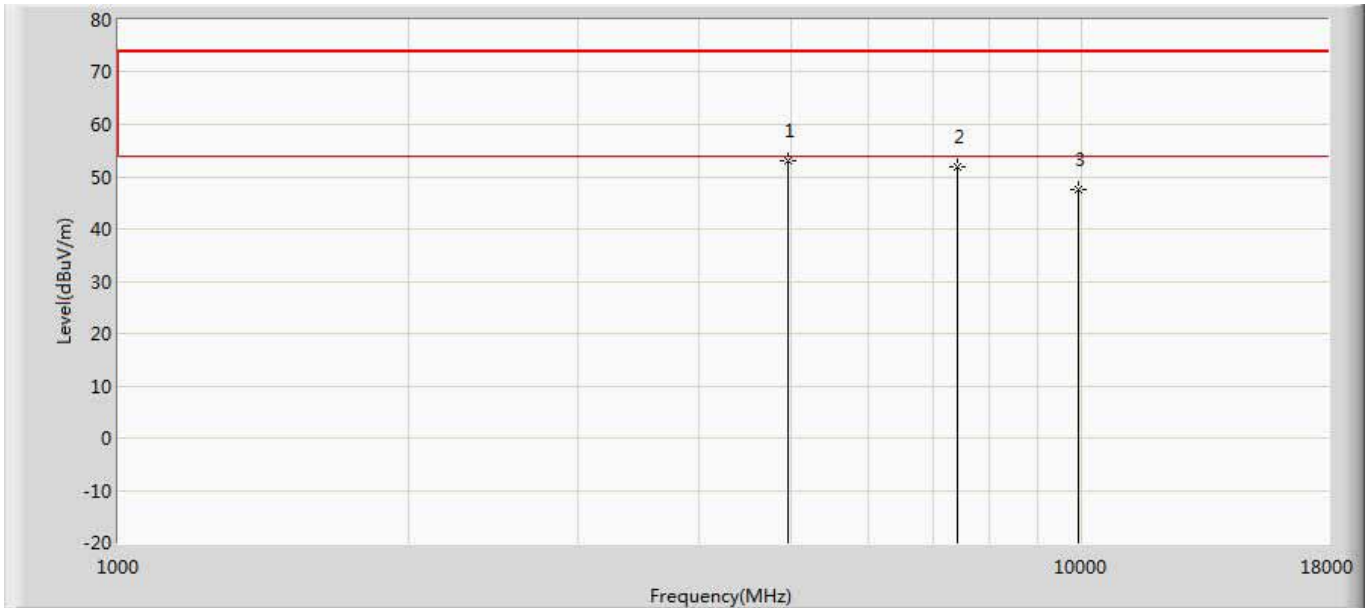

No	Mark	Frequency (MHz)	Measure Level (dBuV/m)	Reading Level (dBuV)	Over Limit (dB)	Limit (dBuV/m)	Factor (dB)	Type
1	*	4960.000	52.997	52.326	-21.003	74.000	0.671	PK
2		7440.000	51.992	47.265	-22.008	74.000	4.727	PK
3		9920.000	47.667	39.266	-26.333	74.000	8.401	PK

Engineer: Karl	
Site: AC5	Time: 2018/11/08 - 00:41
Limit: FCC_Part15.209_RE(3m)	Margin: 0
Probe: Horn_3117_00167055(1-18GHz)	Polarity: Horizontal
EUT: LED lamp	Power: AC 120V/60Hz
Note: Mode 1:Transmit at 2480MHz by Zigbee LTN	

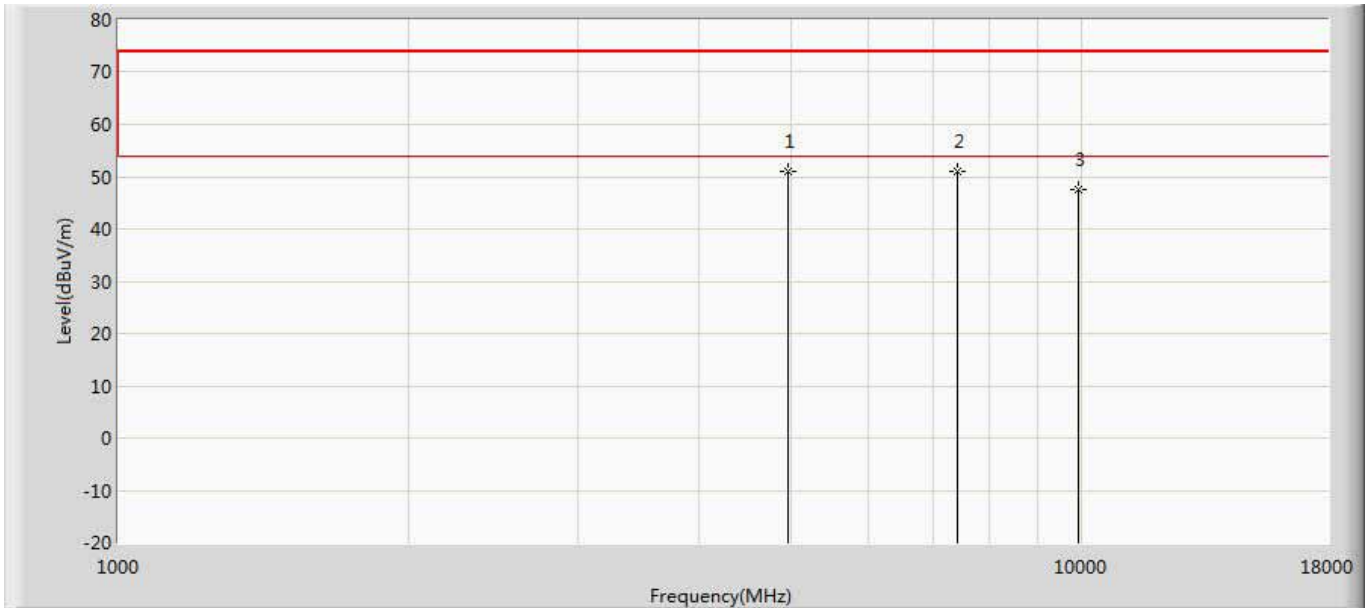

No	Mark	Frequency (MHz)	Measure Level (dBuV/m)	Reading Level (dBuV)	Over Limit (dB)	Limit (dBuV/m)	Factor (dB)	Type
1	*	4960.000	50.996	50.325	-23.004	74.000	0.671	PK
2		7440.000	50.982	46.255	-23.018	74.000	4.727	PK
3		9920.000	47.655	39.254	-26.345	74.000	8.401	PK

**LED lamp(Crystal oscillator: Diode (FL3840023)\_2017; Lighting source: APT)**

Engineer: Karl	
Site: AC5	Time: 2018/11/08 - 00:42
Limit: FCC_Part15.209_RE(3m)	Margin: 0
Probe: Horn_3117_00167055(1-18GHz)	Polarity: Vertical
EUT: LED lamp	Power: AC 120V/60Hz
Note: Mode 1:Transmit at 2405MHz by Zigbee APT	

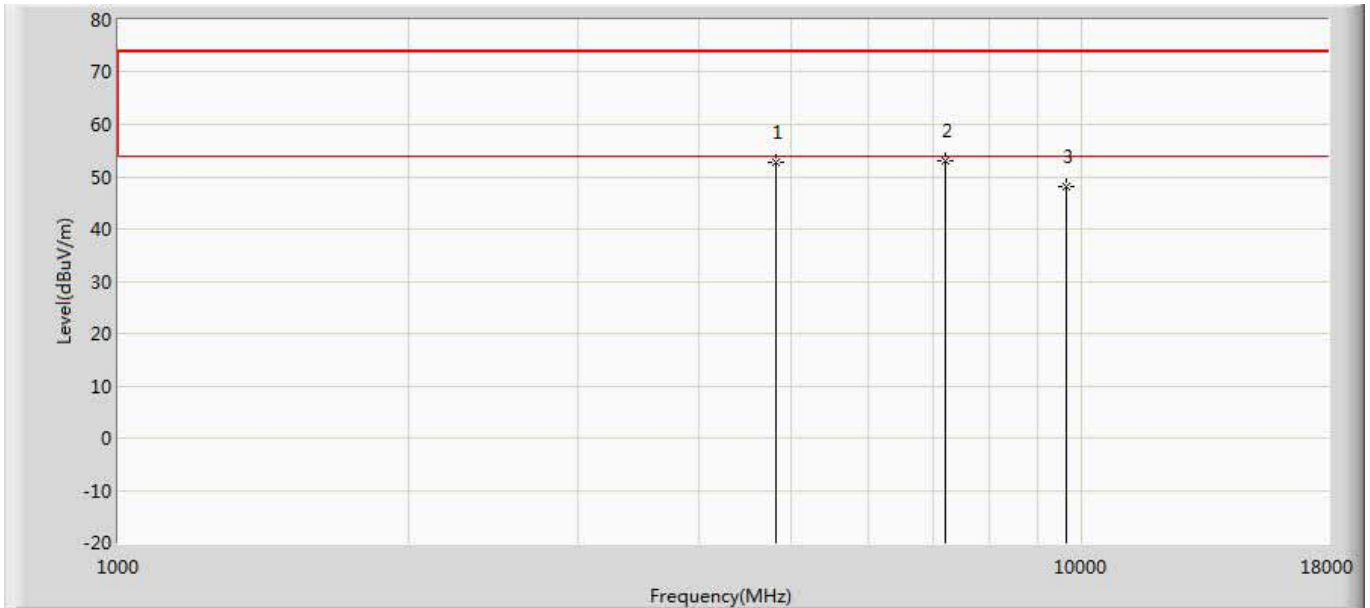

No	Mark	Frequency (MHz)	Measure Level (dBuV/m)	Reading Level (dBuV)	Over Limit (dB)	Limit (dBuV/m)	Factor (dB)	Type
1		4810.000	52.821	52.658	-21.179	74.000	0.162	PK
2	*	7215.000	53.130	49.658	-20.870	74.000	3.472	PK
3		9620.000	48.091	39.658	-25.909	74.000	8.433	PK

Engineer: Karl	
Site: AC5	Time: 2018/11/08 - 00:43
Limit: FCC_Part15.209_RE(3m)	Margin: 0
Probe: Horn_3117_00167055(1-18GHz)	Polarity: Horizontal
EUT: LED lamp	Power: AC 120V/60Hz
Note: Mode 1:Transmit at 2405MHz by Zigbee APT	

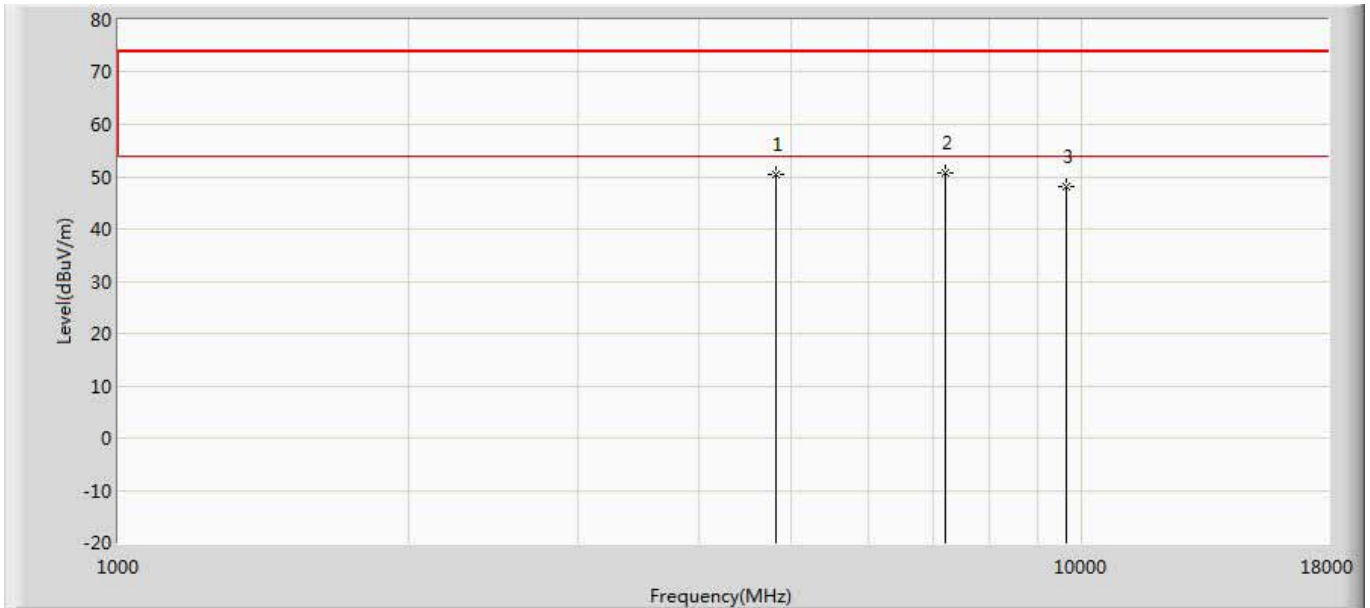

No	Mark	Frequency (MHz)	Measure Level (dBuV/m)	Reading Level (dBuV)	Over Limit (dB)	Limit (dBuV/m)	Factor (dB)	Type
1		4810.000	50.488	50.325	-23.512	74.000	0.162	PK
2	*	7215.000	50.727	47.255	-23.273	74.000	3.472	PK
3		9620.000	48.091	39.658	-25.909	74.000	8.433	PK

Engineer: Karl	
Site: AC5	Time: 2018/11/08 - 00:43
Limit: FCC_Part15.209_RE(3m)	Margin: 0
Probe: Horn_3117_00167055(1-18GHz)	Polarity: Vertical
EUT: LED lamp	Power: AC 120V/60Hz
Note: Mode 1:Transmit at 2450MHz by Zigbee APT	

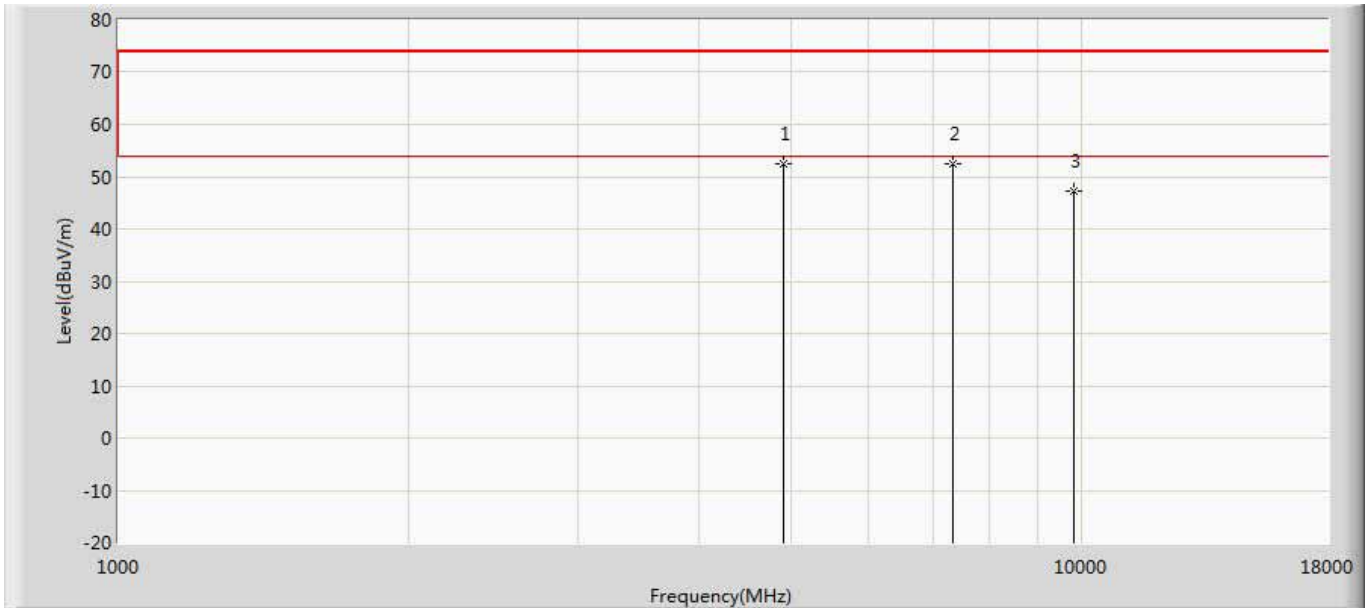

No	Mark	Frequency (MHz)	Measure Level (dBuV/m)	Reading Level (dBuV)	Over Limit (dB)	Limit (dBuV/m)	Factor (dB)	Type
1	*	4900.000	52.540	52.323	-21.460	74.000	0.216	PK
2		7350.000	52.518	48.326	-21.482	74.000	4.192	PK
3		9800.000	47.322	39.658	-26.678	74.000	7.664	PK

Engineer: Karl	
Site: AC5	Time: 2018/11/08 - 00:44
Limit: FCC_Part15.209_RE(3m)	Margin: 0
Probe: Horn_3117_00167055(1-18GHz)	Polarity: Horizontal
EUT: LED lamp	Power: AC 120V/60Hz
Note: Mode 1:Transmit at 2450MHz by Zigbee APT	

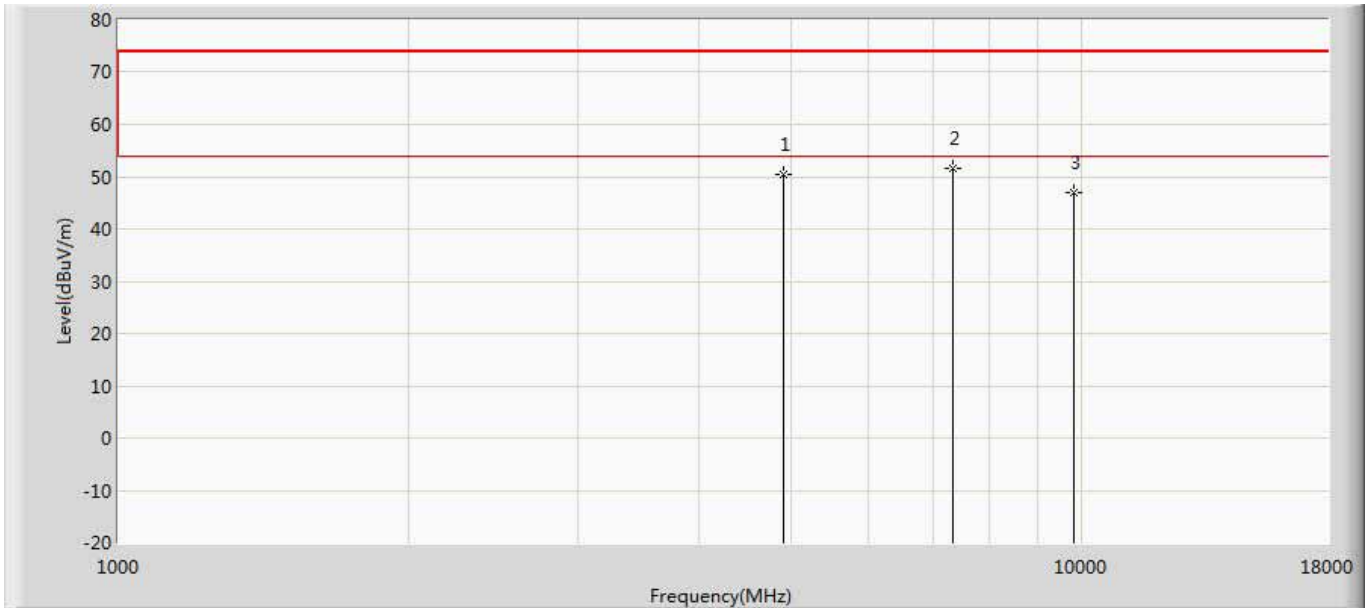

No	Mark	Frequency (MHz)	Measure Level (dBuV/m)	Reading Level (dBuV)	Over Limit (dB)	Limit (dBuV/m)	Factor (dB)	Type
1		4900.000	50.542	50.325	-23.458	74.000	0.216	PK
2	*	7350.000	51.670	47.478	-22.330	74.000	4.192	PK
3		9800.000	46.879	39.215	-27.121	74.000	7.664	PK

Engineer: Karl	
Site: AC5	Time: 2018/11/08 - 00:45
Limit: FCC_Part15.209_RE(3m)	Margin: 0
Probe: Horn_3117_00167055(1-18GHz)	Polarity: Vertical
EUT: LED lamp	Power: AC 120V/60Hz
Note: Mode 1:Transmit at 2480MHz by Zigbee APT	

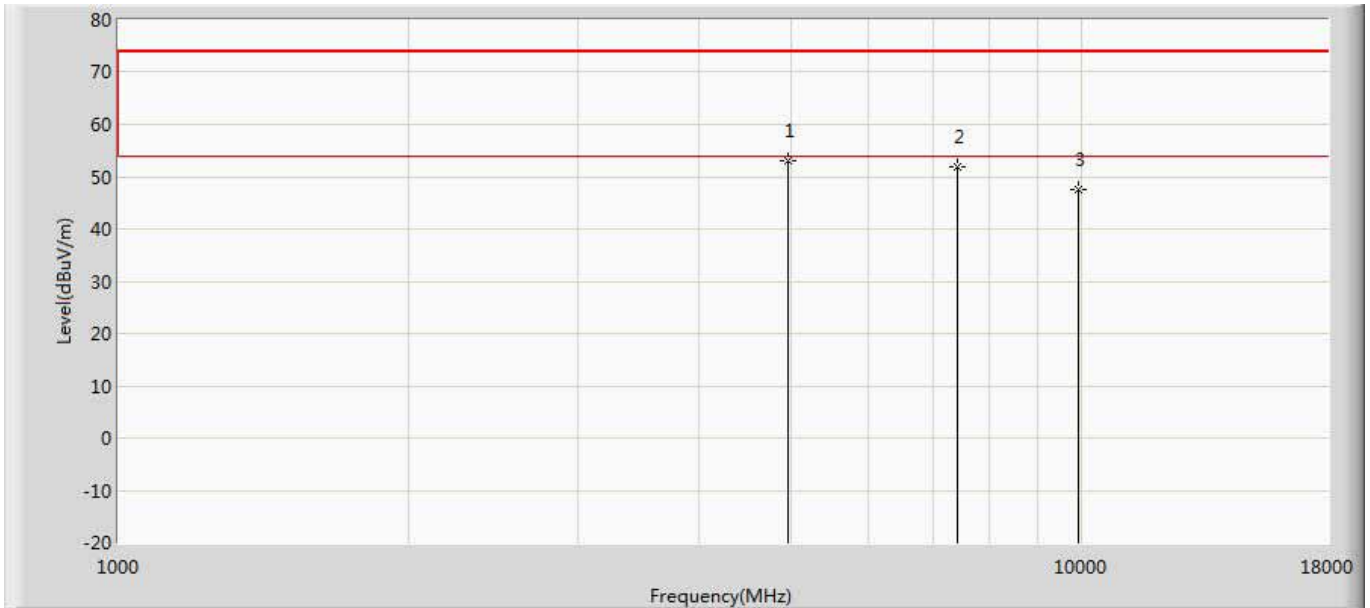

No	Mark	Frequency (MHz)	Measure Level (dBuV/m)	Reading Level (dBuV)	Over Limit (dB)	Limit (dBuV/m)	Factor (dB)	Type
1	*	4960.000	53.025	52.354	-20.975	74.000	0.671	PK
2		7440.000	51.875	47.148	-22.125	74.000	4.727	PK
3		9920.000	47.555	39.154	-26.445	74.000	8.401	PK

Engineer: Karl	
Site: AC5	Time: 2018/11/08 - 00:45
Limit: FCC_Part15.209_RE(3m)	Margin: 0
Probe: Horn_3117_00167055(1-18GHz)	Polarity: Horizontal
EUT: LED lamp	Power: AC 120V/60Hz
Note: Mode 1:Transmit at 2480MHz by Zigbee APT	

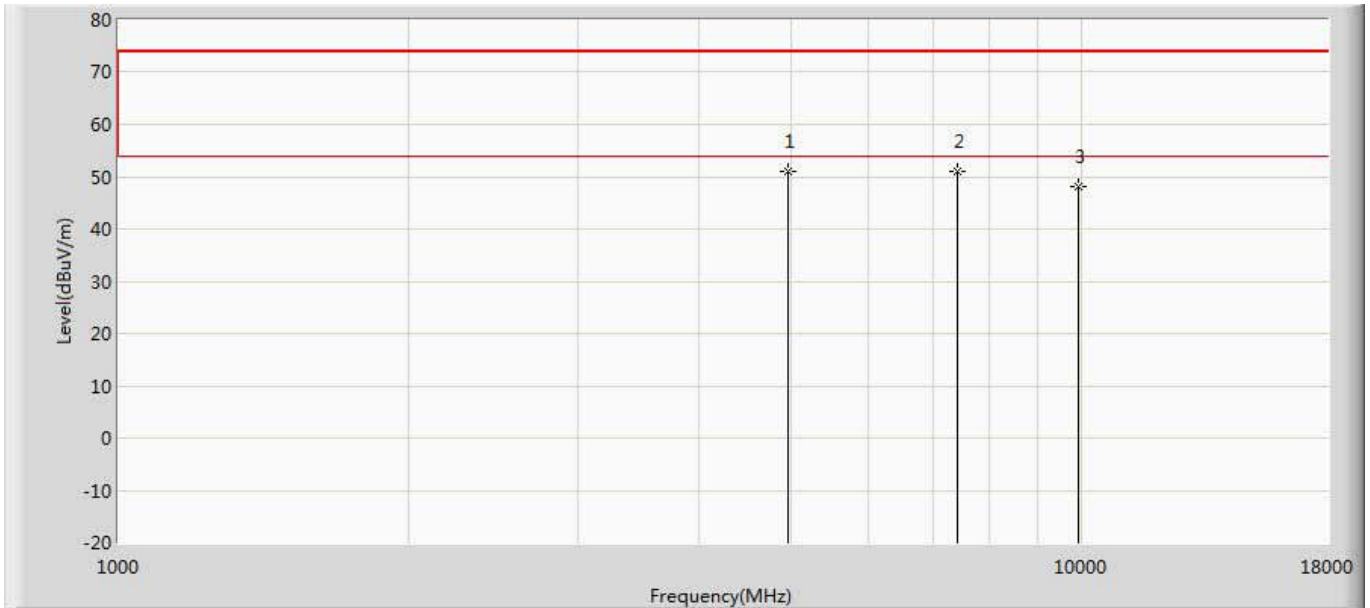

No	Mark	Frequency (MHz)	Measure Level (dBuV/m)	Reading Level (dBuV)	Over Limit (dB)	Limit (dBuV/m)	Factor (dB)	Type
1	*	4960.000	50.996	50.325	-23.004	74.000	0.671	PK
2		7440.000	50.941	46.214	-23.059	74.000	4.727	PK
3		9920.000	48.054	39.653	-25.946	74.000	8.401	PK

**Note:**

1. Measured Level = Reading Level + Factor.
2. The test frequency range, 9kHz~30MHz, 18GHz~26GHz, both of the worst case are at least 20dB below the limits, therefore no data appear in the report.
3. This limit applies for using average detector, if the test result on peak is lower than average limit, then average measurement needn't be performed.
4. As the radiated emission was performed, so conducted emission was not tested.



### The worst case of Radiated Emission below 1GHz:

Engineer: CptJack	
Site: AC2	Time: 2018/12/10
Limit: FCC_Part15.209_RE(3m)	Margin: 0
Probe: AC2_3M(30-1000M)	Polarity: Horizontal
EUT: LED lamp	Power: AC 120V/60Hz
Note: Diode (FL3840023)_2017(APT)	

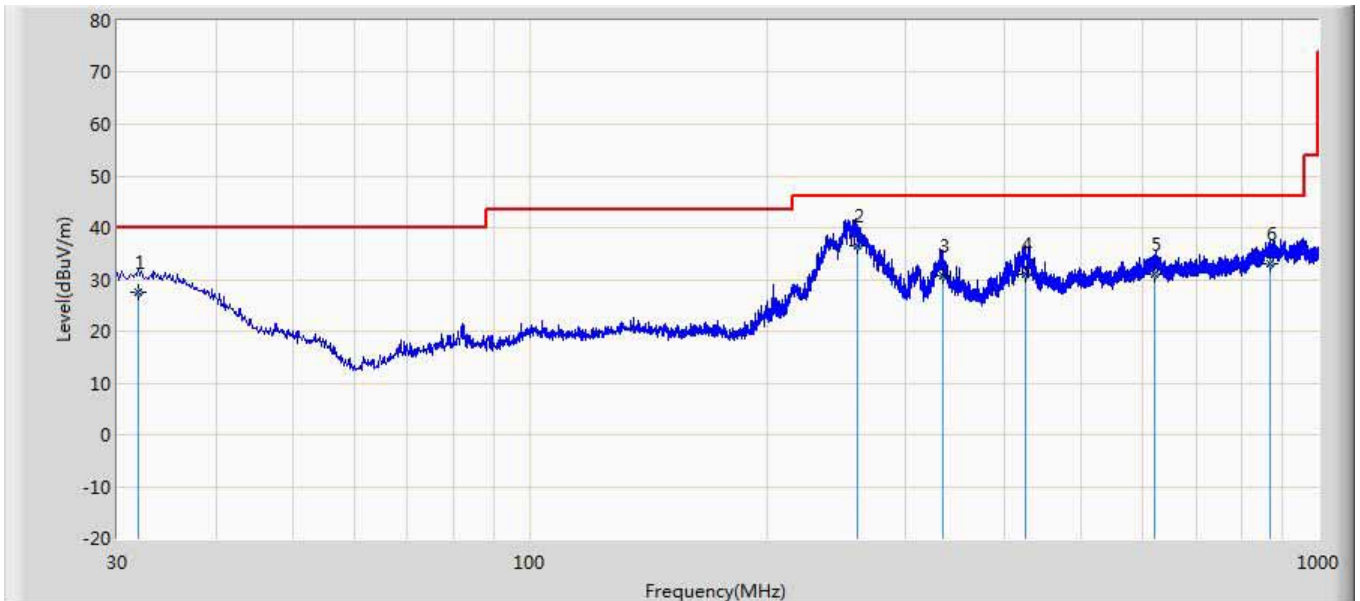

No	Mark	Frequency (MHz)	Measure Level (dBuV/m)	Reading Level (dBuV)	Over Limit (dB)	Limit (dBuV/m)	Probe (dB/m)	Cable (dB)	Amp (dB)	Ant Pos (cm)	Table Pos (deg)	Type
1		31.894	27.593	0.200	-12.407	40.000	20.754	6.640	0.000	100	331	QP
2	*	259.864	36.579	17.500	-9.421	46.000	11.499	7.580	0.000	100	192	QP
3		334.714	30.826	7.900	-15.174	46.000	15.192	7.734	0.000	200	281	QP
4		424.560	31.006	3.700	-14.994	46.000	19.334	7.972	0.000	200	195	QP
5		621.345	31.123	0.300	-14.877	46.000	22.262	8.560	0.000	200	187	QP
6		869.294	33.137	0.100	-12.863	46.000	23.861	9.176	0.000	100	251	QP

**Note:**

- " \* ", means this data is the worst emission level.
- Measurement Level = Reading Level + Factor(Probe+Cable-Amp).

Engineer: CptJack	
Site: AC2	Time: 2018/12/10
Limit: FCC_Part15.209_RE(3m)	Margin: 0
Probe: AC2_3M(30-1000M)	Polarity: Vertical
EUT: LED lamp	Power: AC 120V/60Hz
Note: Diode (FL3840023)_2017(APT)	

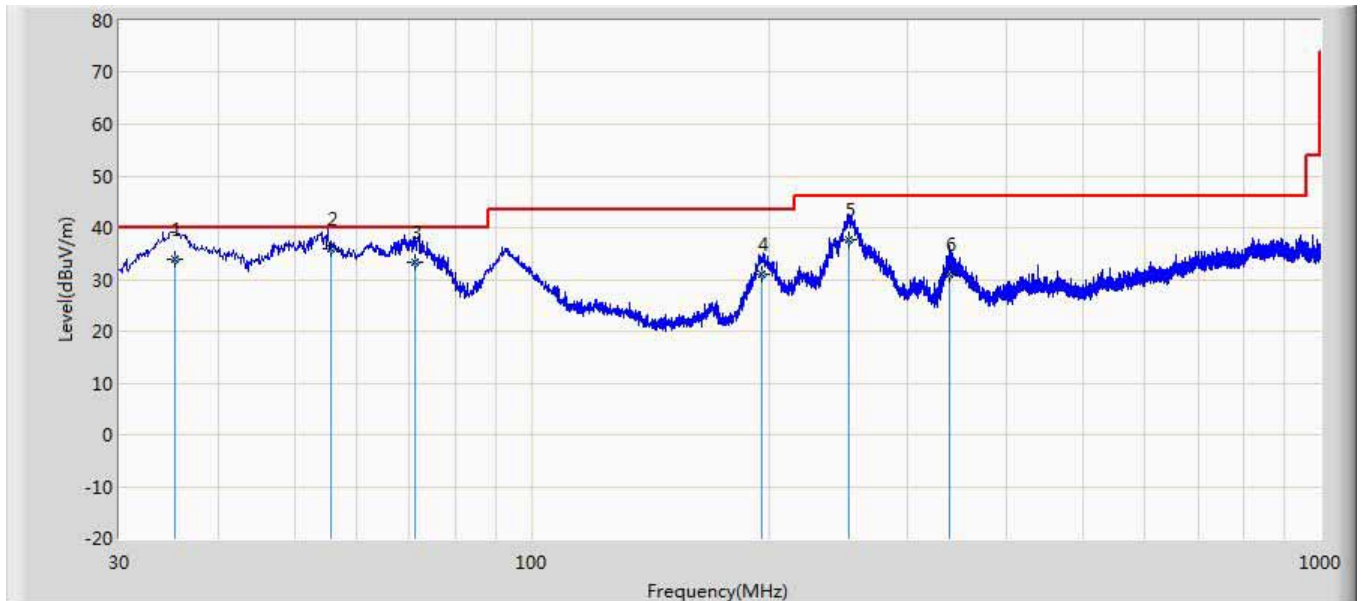

No	Mark	Frequency (MHz)	Measure Level (dBuV/m)	Reading Level (dBuV)	Over Limit (dB)	Limit (dBuV/m)	Probe (dB/m)	Cable (dB)	Amp (dB)	Ant Pos (cm)	Table Pos (deg)	Type
1		35.296	33.856	11.200	-6.144	40.000	15.995	6.661	0.000	100	312	QP
2	*	55.594	35.905	18.500	-4.095	40.000	10.763	6.642	0.000	100	135	QP
3		71.261	33.354	18.651	-6.646	40.000	8.027	6.676	0.000	100	201	QP
4		196.234	31.057	8.421	-12.443	43.500	15.304	7.333	0.000	200	281	QP
5		252.896	37.802	13.200	-8.198	46.000	17.030	7.573	0.000	100	42	QP
6		338.529	30.982	7.400	-15.018	46.000	15.835	7.747	0.000	100	80	QP

Note:

1. " \* ", means this data is the worst emission level.
2. Measurement Level = Reading Level + Factor(Probe+Cable-Amp).

Engineer: CptJack	
Site: AC2	Time: 2018/12/10
Limit: FCC_Part15.209_RE(3m)	Margin: 0
Probe: AC2_3M(30-1000M)	Polarity: Horizontal
EUT: LED lamp	Power: AC 120V/60Hz
Note: Diode (FL3840023)_2017(LTN)	

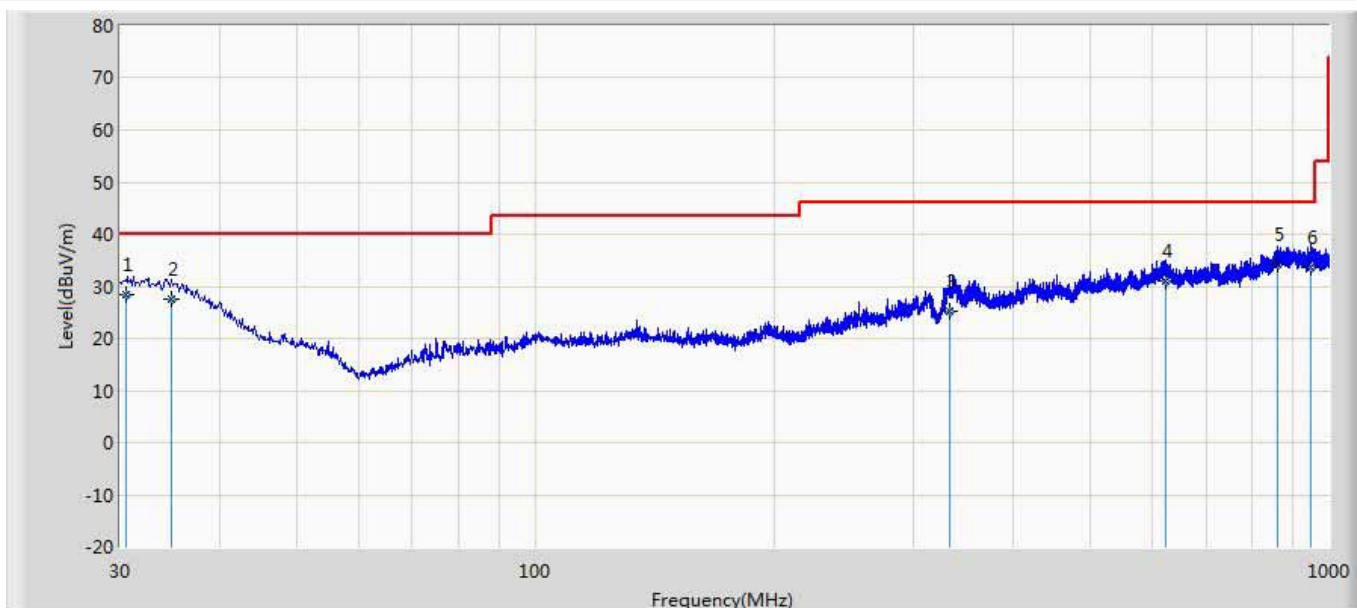

No	Mark	Frequency (MHz)	Measure Level (dBuV/m)	Reading Level (dBuV)	Over Limit (dB)	Limit (dBuV/m)	Probe (dB/m)	Cable (dB)	Amp (dB)	Ant Pos (cm)	Table Pos (deg)	Type
1	*	30.594	28.305	0.700	-11.695	40.000	20.979	6.626	0.000	100	215	QP
2		34.769	27.445	0.100	-12.555	40.000	20.676	6.669	0.000	200	166	QP
3		333.284	25.331	2.400	-20.669	46.000	15.201	7.730	0.000	100	201	QP
4		624.164	31.031	0.300	-14.969	46.000	22.164	8.567	0.000	200	194	QP
5		860.894	34.108	1.500	-11.892	46.000	23.453	9.156	0.000	200	331	QP
6		949.896	33.532	0.200	-12.468	46.000	23.982	9.350	0.000	100	284	QP

Note:

1. " \* ", means this data is the worst emission level.
2. Measurement Level = Reading Level + Factor(Probe+Cable-Amp).

Engineer: CptJack	
Site: AC2	Time: 2018/12/10
Limit: FCC_Part15.209_RE(3m)	Margin: 0
Probe: AC2_3M(30-1000M)	Polarity: Vertical
EUT: LED lamp	Power: AC 120V/60Hz
Note: Diode (FL3840023)_2017(LTN)	

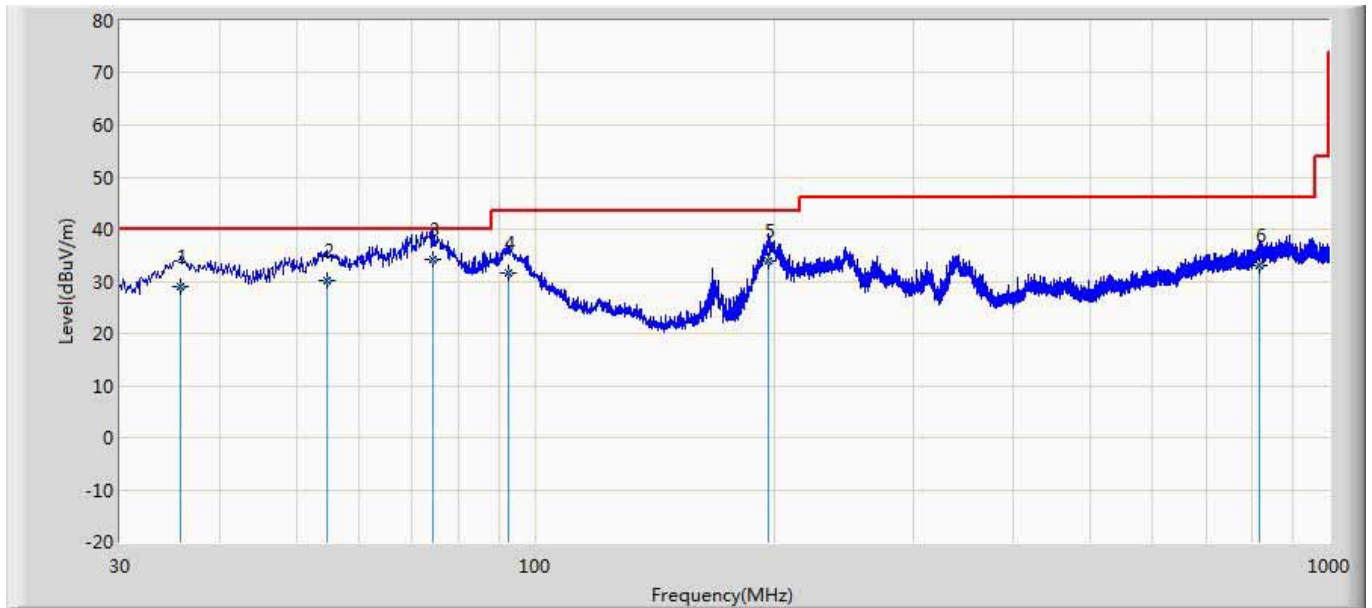

No	Mark	Frequency (MHz)	Measure Level (dBuV/m)	Reading Level (dBuV)	Over Limit (dB)	Limit (dBuV/m)	Probe (dB/m)	Cable (dB)	Amp (dB)	Ant Pos (cm)	Table Pos (deg)	Type
1		35.794	29.018	6.700	-10.982	40.000	15.667	6.651	0.000	200	52	QP
2		54.594	30.242	12.500	-9.758	40.000	11.118	6.624	0.000	100	102	QP
3	*	74.284	34.343	20.300	-5.657	40.000	7.376	6.667	0.000	200	255	QP
4		92.351	31.628	13.400	-11.872	43.500	11.451	6.777	0.000	100	142	QP
5		196.561	33.922	11.200	-9.578	43.500	15.389	7.333	0.000	200	284	QP
6		816.296	33.078	0.100	-12.922	46.000	23.929	9.049	0.000	100	284	QP

**Note:**

1. " \* ", means this data is the worst emission level.
2. Measurement Level = Reading Level + Factor(Probe+Cable-Amp).

**LED lamp (Crystal oscillator: Murata(XRCGB38M400FXH17R0))**

Engineer: Karl	
Site: AC5	Time: 2018/11/08 - 00:09
Limit: FCC_Part15.209_RE(3m)	Margin: 0
Probe: Horn_3117_00167055(1-18GHz)	Polarity: Vertical
EUT: LED lamp	Power: AC 120V/60Hz
Note: Mode 1:Transmit at 2405MHz by Zigbee	

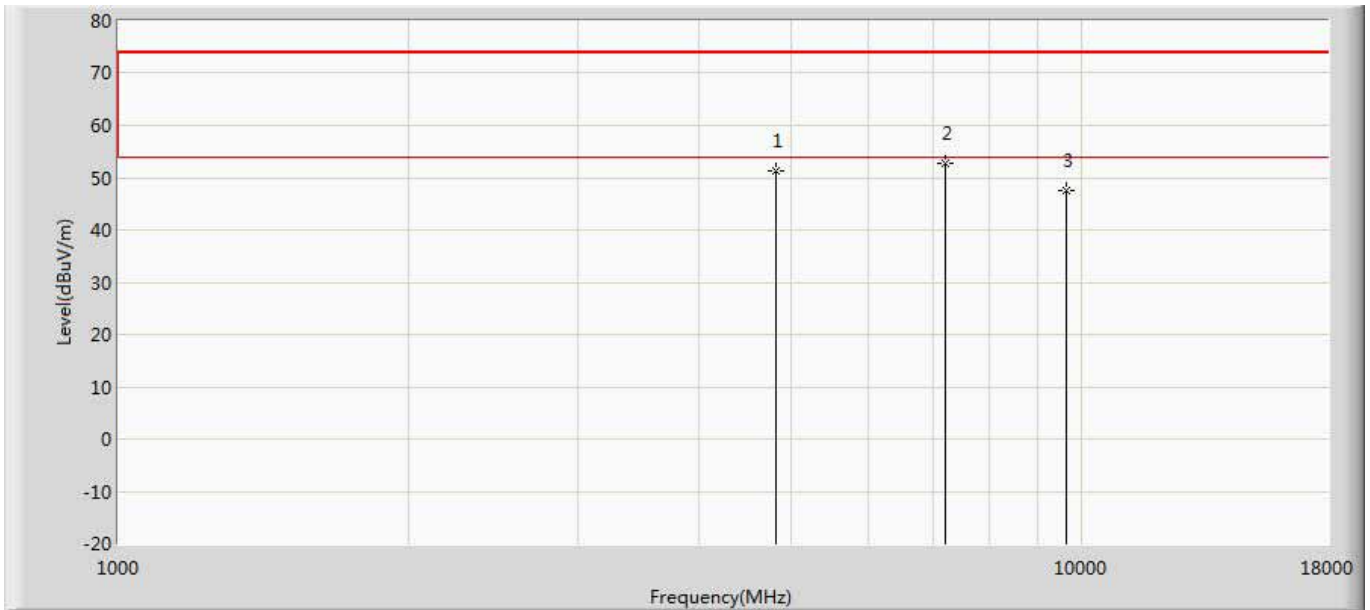

No	Mark	Frequency (MHz)	Measure Level (dBuV/m)	Reading Level (dBuV)	Over Limit (dB)	Limit (dBuV/m)	Factor (dB)	Type
1		4810.000	51.378	51.215	-22.622	74.000	0.162	PK
2	*	7215.000	52.737	49.265	-21.263	74.000	3.472	PK
3		9620.000	47.587	39.154	-26.413	74.000	8.433	PK

Engineer: Karl	
Site: AC5	Time: 2018/11/08 - 00:10
Limit: FCC_Part15.209_RE(3m)	Margin: 0
Probe: Horn_3117_00167055(1-18GHz)	Polarity: Horizontal
EUT: LED lamp	Power: AC 120V/60Hz
Note: Mode 1:Transmit at 2405MHz by Zigbee	

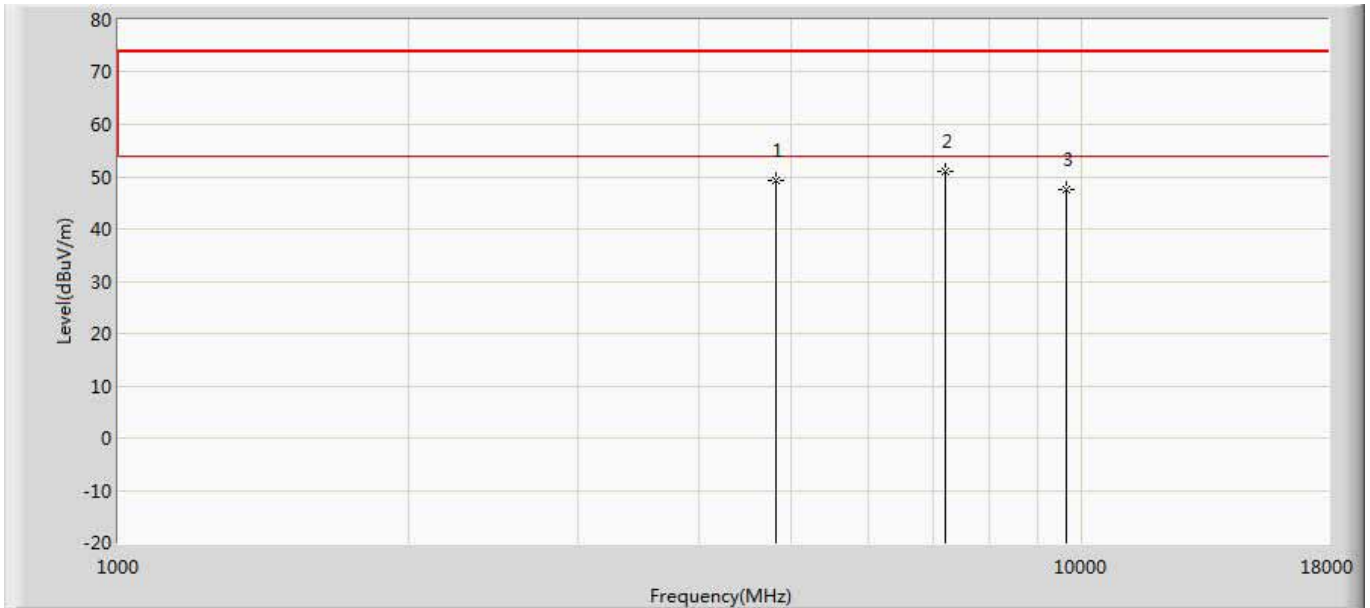

No	Mark	Frequency (MHz)	Measure Level (dBuV/m)	Reading Level (dBuV)	Over Limit (dB)	Limit (dBuV/m)	Factor (dB)	Type
1		4810.000	49.417	49.254	-24.583	74.000	0.162	PK
2	*	7215.000	51.020	47.548	-22.980	74.000	3.472	PK
3		9620.000	47.619	39.186	-26.381	74.000	8.433	PK

Engineer: Karl	
Site: AC5	Time: 2018/11/08 - 00:10
Limit: FCC_Part15.209_RE(3m)	Margin: 0
Probe: Horn_3117_00167055(1-18GHz)	Polarity: Vertical
EUT: LED lamp	Power: AC 120V/60Hz
Note: Mode 1:Transmit at 2450MHz by Zigbee	

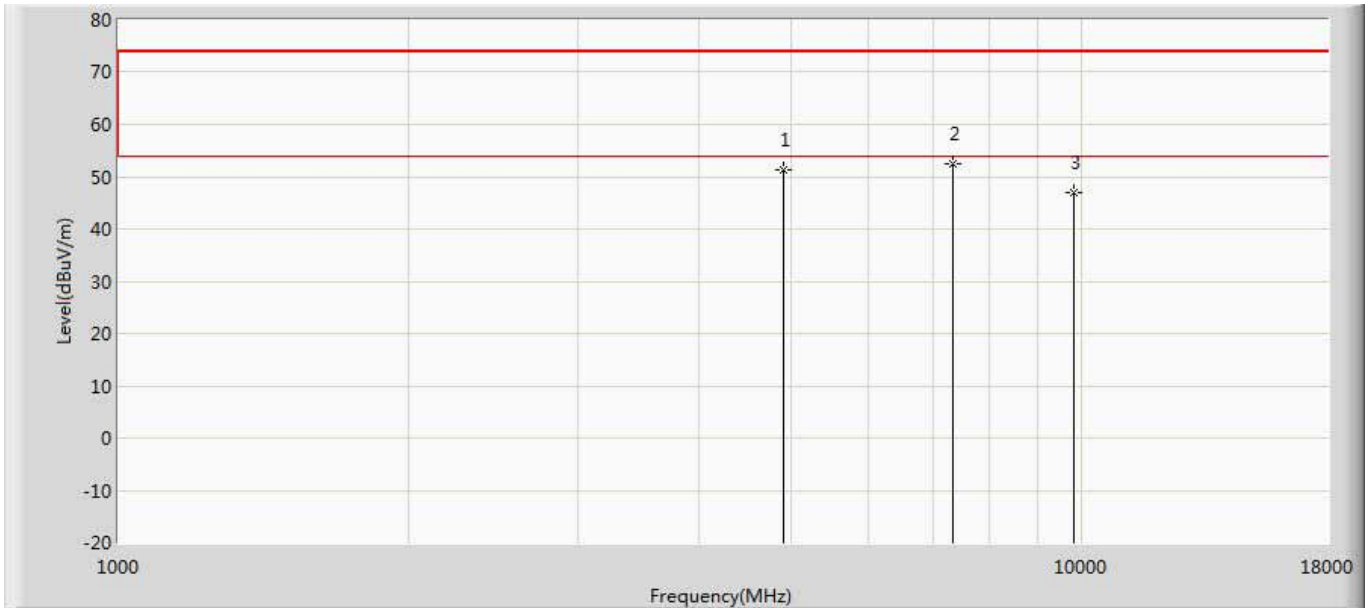

No	Mark	Frequency (MHz)	Measure Level (dBuV/m)	Reading Level (dBuV)	Over Limit (dB)	Limit (dBuV/m)	Factor (dB)	Type
1		4900.000	51.432	51.215	-22.568	74.000	0.216	PK
2	*	7350.000	52.349	48.157	-21.651	74.000	4.192	PK
3		9800.000	46.880	39.216	-27.120	74.000	7.664	PK

Engineer: Karl	
Site: AC5	Time: 2018/11/08 - 00:11
Limit: FCC_Part15.209_RE(3m)	Margin: 0
Probe: Horn_3117_00167055(1-18GHz)	Polarity: Horizontal
EUT: LED lamp	Power: AC 120V/60Hz
Note: Mode 1:Transmit at 2450MHz by Zigbee	

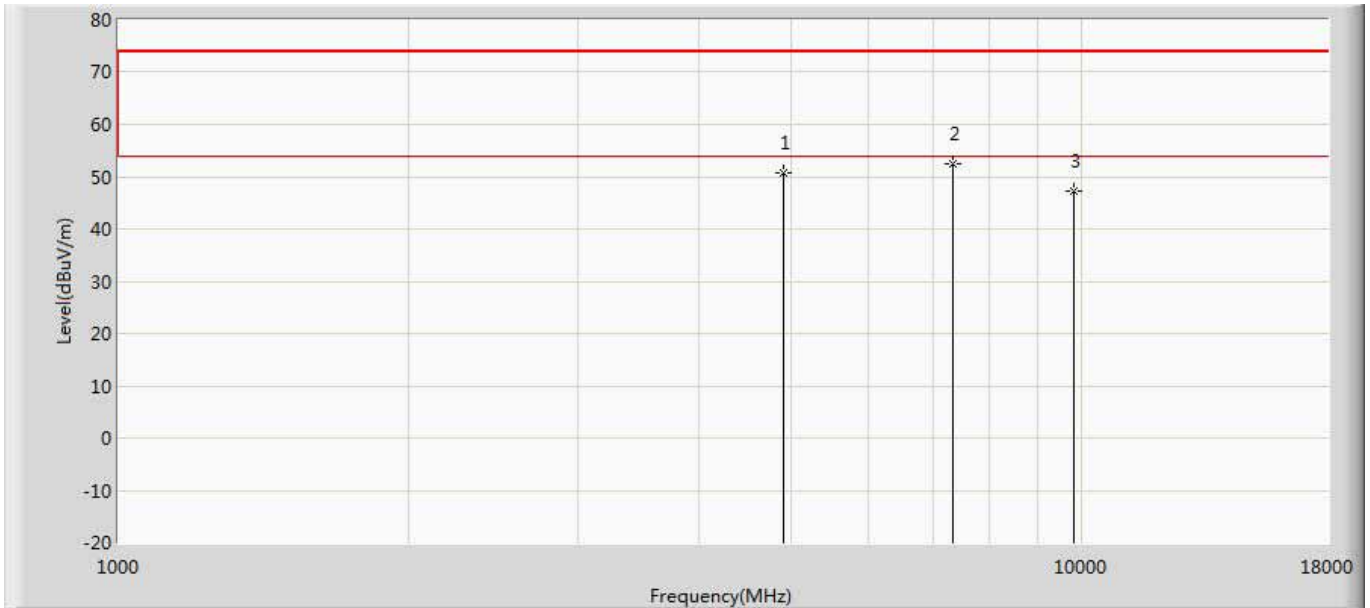

No	Mark	Frequency (MHz)	Measure Level (dBuV/m)	Reading Level (dBuV)	Over Limit (dB)	Limit (dBuV/m)	Factor (dB)	Type
1		4900.000	50.705	50.488	-23.295	74.000	0.216	PK
2	*	7350.000	52.418	48.226	-21.582	74.000	4.192	PK
3		9800.000	47.115	39.451	-26.885	74.000	7.664	PK



Engineer: Karl	
Site: AC5	Time: 2018/11/08 - 00:36
Limit: FCC_Part15.209_RE(3m)	Margin: 0
Probe: Horn_3117_00167055(1-18GHz)	Polarity: Vertical
EUT: LED lamp	Power: AC 120V/60Hz
Note: Mode 1:Transmit at 2480MHz by Zigbee	

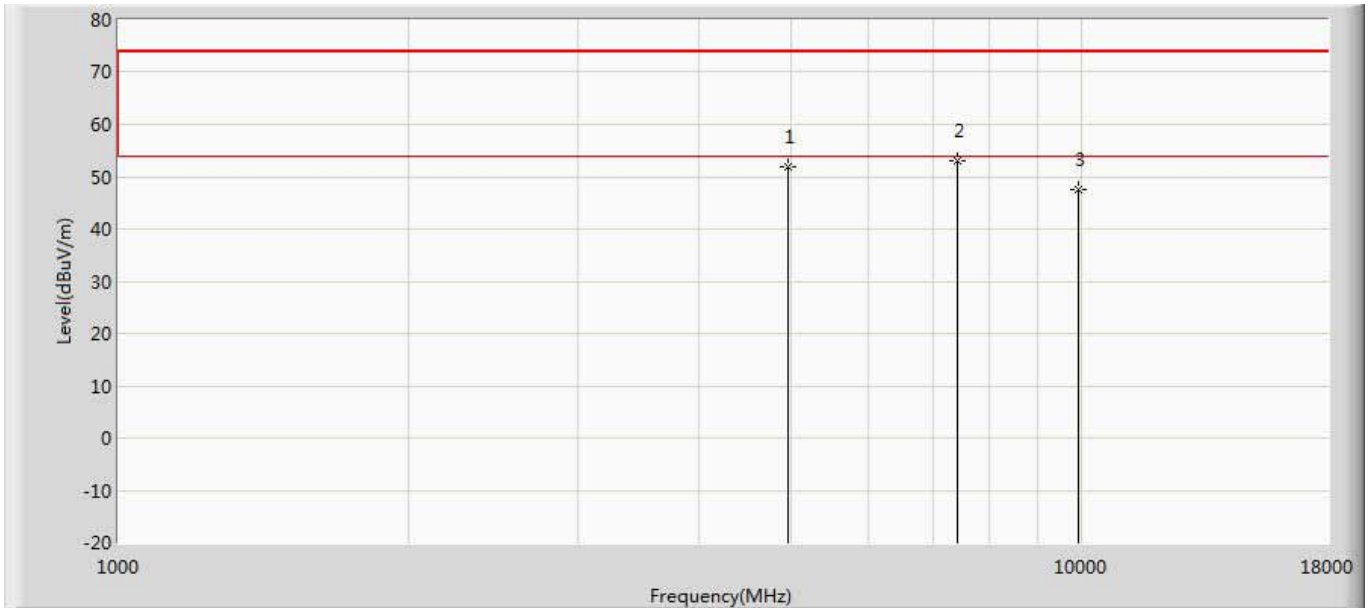

No	Mark	Frequency (MHz)	Measure Level (dBuV/m)	Reading Level (dBuV)	Over Limit (dB)	Limit (dBuV/m)	Factor (dB)	Type
1		4960.000	51.886	51.215	-22.114	74.000	0.671	PK
2	*	7440.000	52.992	48.265	-21.008	74.000	4.727	PK
3		9920.000	47.556	39.155	-26.444	74.000	8.401	PK

Engineer: Karl	
Site: AC5	Time: 2018/11/08 - 00:36
Limit: FCC_Part15.209_RE(3m)	Margin: 0
Probe: Horn_3117_00167055(1-18GHz)	Polarity: Horizontal
EUT: LED lamp	Power: AC 120V/60Hz
Note: Mode 1:Transmit at 2480MHz by Zigbee	

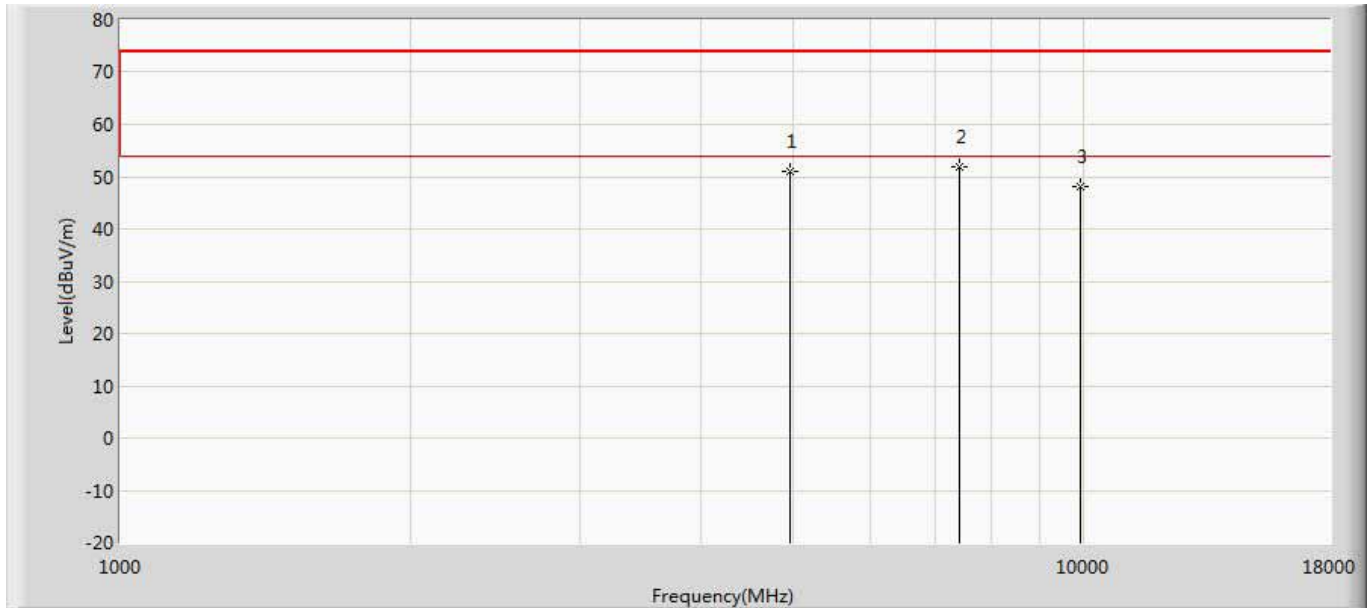

No	Mark	Frequency (MHz)	Measure Level (dBuV/m)	Reading Level (dBuV)	Over Limit (dB)	Limit (dBuV/m)	Factor (dB)	Type
1		4960.000	51.158	50.487	-22.842	74.000	0.671	PK
2	*	7440.000	51.852	47.125	-22.148	74.000	4.727	PK
3		9920.000	48.022	39.621	-25.978	74.000	8.401	PK

**Note:**

1. Measured Level = Reading Level + Factor.
2. The test frequency range, 9kHz~30MHz, 18GHz~26GHz, both of the worst case are at least 20dB below the limits, therefore no data appear in the report.
3. This limit applies for using average detector, if the test result on peak is lower than average limit, then average measurement needn't be performed.
4. As the radiated emission was performed, so conducted emission was not tested.

### The worst case of Radiated Emission below 1GHz:

Engineer: CptJack	
Site: AC2	Time: 2018/12/10
Limit: FCC_Part15.209_RE(3m)	Margin: 0
Probe: AC2_3M(30-1000M)	Polarity: Horizontal
EUT: LED lamp	Power: AC 120V/60Hz
Note: Mode 1:Transmit at 2405MHz by Zigbee	

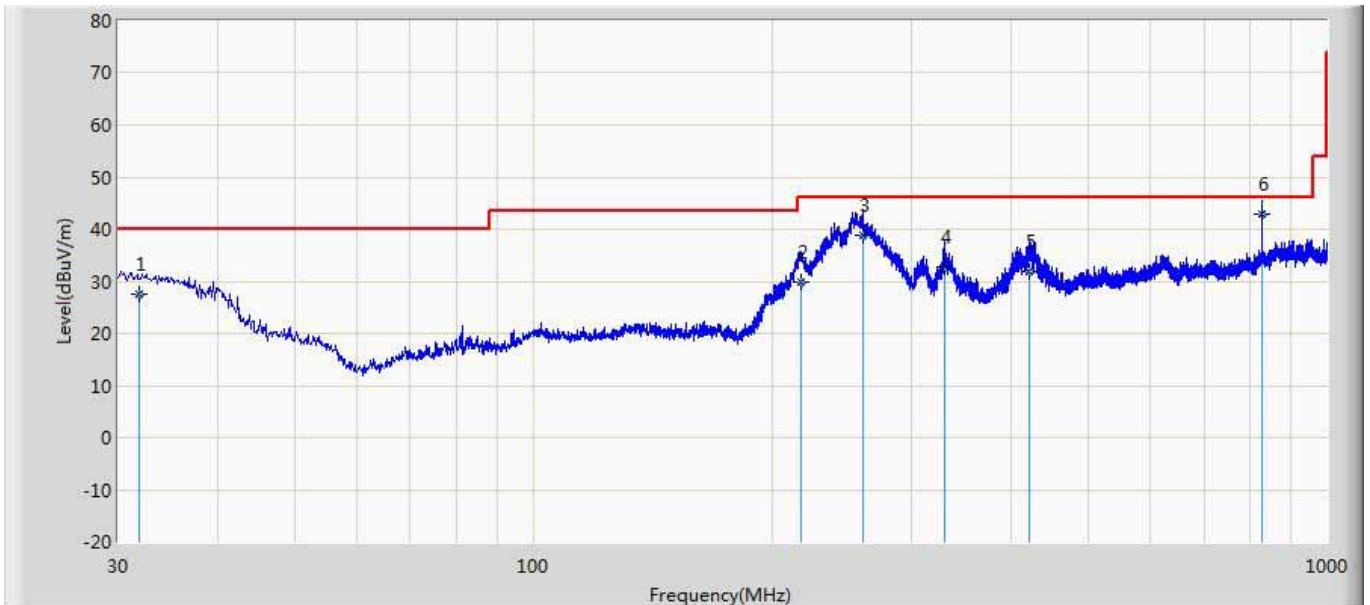

No	Mark	Frequency (MHz)	Measure Level (dBuV/m)	Reading Level (dBuV)	Over Limit (dB)	Limit (dBuV/m)	Probe (dB/m)	Cable (dB)	Amp (dB)	Ant Pos (cm)	Table Pos (deg)	Type
1		31.894	27.493	0.100	-12.507	40.000	20.754	6.640	0.000	100	21	QP
2		217.794	29.881	12.500	-16.119	46.000	9.959	7.422	0.000	100	186	QP
3		259.861	38.779	19.700	-7.221	46.000	11.499	7.580	0.000	200	163	QP
4		330.564	32.718	9.800	-13.282	46.000	15.197	7.721	0.000	200	347	QP
5		422.530	31.930	4.700	-14.070	46.000	19.260	7.970	0.000	200	166	QP
6	*	827.084	42.946	11.200	-3.054	46.000	22.671	9.074	0.000	100	283	QP

**Note:**

1. " \* ", means this data is the worst emission level.
2. Measurement Level = Reading Level + Factor(Probe+Cable-Amp).

Engineer: CptJack	
Site: AC2	Time: 2018/12/10
Limit: FCC_Part15.209_RE(3m)	Margin: 0
Probe: AC2_3M(30-1000M)	Polarity: Vertical
EUT: LED lamp	Power: AC 120V/60Hz
Note: Mode 1:Transmit at 2405MHz by Zigbee	

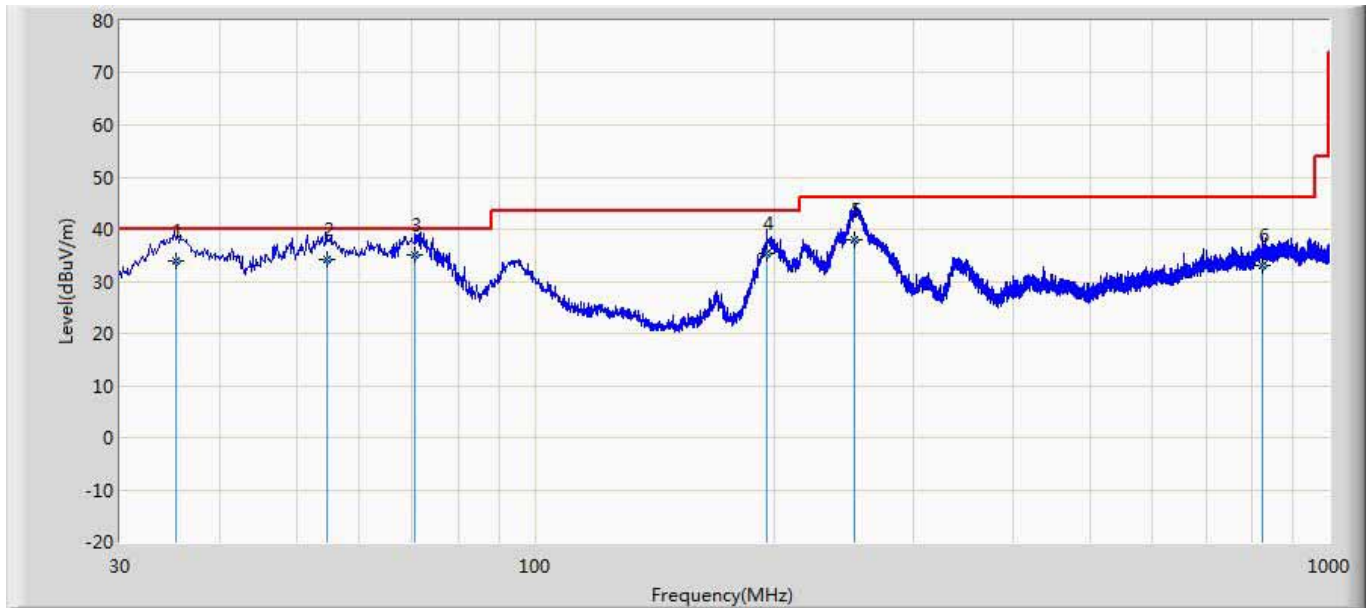

No	Mark	Frequency (MHz)	Measure Level (dBuV/m)	Reading Level (dBuV)	Over Limit (dB)	Limit (dBuV/m)	Probe (dB/m)	Cable (dB)	Amp (dB)	Ant Pos (cm)	Table Pos (deg)	Type
1		35.294	33.957	11.300	-6.043	40.000	15.997	6.661	0.000	200	53	QP
2		54.594	34.242	16.500	-5.758	40.000	11.118	6.624	0.000	100	315	QP
3	*	70.594	34.966	20.100	-5.034	40.000	8.188	6.677	0.000	200	33	QP
4		195.861	35.239	12.700	-8.261	43.500	15.207	7.332	0.000	100	314	QP
5		252.161	38.029	13.400	-7.971	46.000	17.057	7.572	0.000	100	220	QP
6		824.296	32.956	0.300	-13.044	46.000	23.588	9.068	0.000	100	294	QP

Note:

- " \* ", means this data is the worst emission level.
- Measurement Level = Reading Level + Factor(Probe+Cable-Amp).

## 5. Emissions in non-restricted frequency bands

### 5.1. Test Equipment

Emissions in non-restricted frequency bands / TR-8					
Instrument	Manufacturer	Type No.	Serial No.	Cal. Date	Cal. Due Date
Spectrum Analyzer	Agilent	N9010A	MY48030494	2018.02.04	2019.02.03
EXA Spectrum Analyzer	Keysight	N9010A	MY55370495	2018.04.09	2019.04.08
MXA Signal Analyzer	Keysight	N9020A	MY56060147	2018.04.09	2019.04.08
Temperature/Humidity Meter	zhichen	ZC1-2	TR8-TH	2018.04.10	2019.04.09

Note: All equipment are calibrated with traceable calibrations. Each calibration is traceable to the national or international standards.

### 5.2. Test Setup

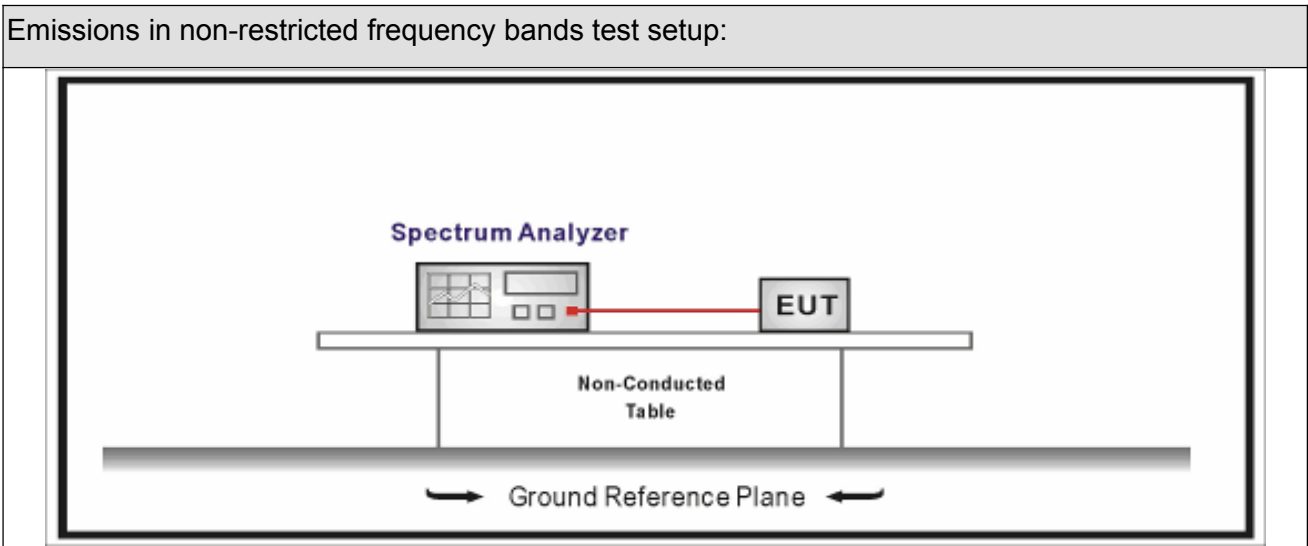





### 5.3. Limit

Un-Restricted Band Emissions Limit	
RF Output power (Detection methods)	Limit(dB)
RF Output power(Average detector)	30c(Note1)
RF Output power(PK detector)	20c(Note2)
<p>Note 1: If maximum conducted (average) output power was used to demonstrate compliance as described in 9.2, then the peak power in any 100 kHz bandwidth outside of the authorized frequency band shall be attenuated by at least 30 dB relative to the maximum in-band peak PSD level in 100 kHz (i.e., 30 dBc).</p> <p>Note 2: If the maximum peak conducted output power procedure was used, then the peak output power measured in any 100 kHz bandwidth outside of the authorized frequency band shall be attenuated by at least 20 dB relative to the maximum in-band peak PSD level in 100 kHz (i.e., 20 dBc).</p>	

### 5.4. Test Procedure

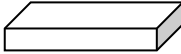
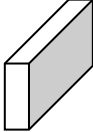
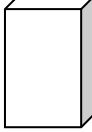
Test Method			
	References Rule	Chapter	Description
<input checked="" type="checkbox"/>	ANSI C63.10	11.11	Emissions in non-restricted frequency bands
	<input checked="" type="checkbox"/> ANSI C63.10	11.11.2	Reference level measurement
	<input checked="" type="checkbox"/> ANSI C63.10	11.11.3	Emission level measurement
<input type="checkbox"/>	ANSI C63.10	11.12	Emissions in restricted frequency bands
	<input type="checkbox"/> ANSI C63.10	11.12.1	Radiated emission measurements
	<input type="checkbox"/> ANSI C63.10	11.12.2.7	Radiated spurious emission test
<input type="checkbox"/>	ANSI C63.10	6.4	Radiated emissions from unlicensed wireless devices below 30 MHz
<input type="checkbox"/>	ANSI C63.10	6.5	Radiated emissions from unlicensed wireless devices in the frequency range of 30 MHz to 1000 MHz
<input type="checkbox"/>	ANSI C63.10	6.6	Radiated emissions from unlicensed wireless devices above 1 GHz
	<input checked="" type="checkbox"/> ANSI C63.10	11.12.2	Antenna-port conducted measurements
	<input type="checkbox"/> ANSI C63.10	11.12.2.3	Quasi-peak measurement procedure
	<input checked="" type="checkbox"/> ANSI C63.10	11.12.2.4	Peak power measurement procedure
	<input type="checkbox"/> ANSI C63.10	11.12.2.5	Average power measurement procedures
	<input type="checkbox"/> ANSI C63.10	11.12.2.5.1	Trace averaging with continuous EUT transmission at full power
	<input type="checkbox"/> ANSI C63.10	11.12.2.5.2	Trace averaging across ON and OFF times of the EUT transmissions followed by duty cycle correction
	<input type="checkbox"/> ANSI C63.10	11.12.2.5.3	Reduced VBW averaging across ON and OFF times of the EUT transmissions with max hold

**5.5. EUT test Axis definition**

Item	Emissions in non-restricted frequency bands			
Device Category	<input type="checkbox"/>	Fixed point-to-point		
	<input type="checkbox"/>	Emit multiple directional beams, simultaneously or sequentially		
	<input checked="" type="checkbox"/>	Other cases		
Test mode	Mode 1			
Test method	<input type="checkbox"/>	Radiated		
		X Axis	Y Axis	Z Axis
				
		Worst Axis <input type="checkbox"/>	Worst Axis <input type="checkbox"/>	Worst Axis <input type="checkbox"/>
	<input checked="" type="checkbox"/>	Conducted		
	<input checked="" type="checkbox"/>	Chain 0		
				
	<input type="checkbox"/>	Chain 0	Chain 1	
				
	<input type="checkbox"/>	Chain 0	Chain 1	Chain 2
				



### 5.6. Test Result

Product Name	: LED lamp	Power	: AC 120V/60Hz
Test Mode	: Mode 1	Test Site	: TR-8
Test Date	: 2018.11.08	Test engineer	: Tommie

Mode	Channel	Test Frequency (MHz)	In-Band PSD[a] (dBm/100kHz)	Frequency (MHz)	Out-Band PSD[b] (dBm/100kHz)	[a]-[b] (dB)	Limit (dB)	Result
1	11	2405	4.948	2405.09	-46.647	51.595	>20	Pass
1	26	2480	4.433	2500.00	-55.403	59.836	>20	Pass

Note: The worst case of Emissions in non-restricted frequency bands as below:

#### Mode 1 CH11 (2405MHz)

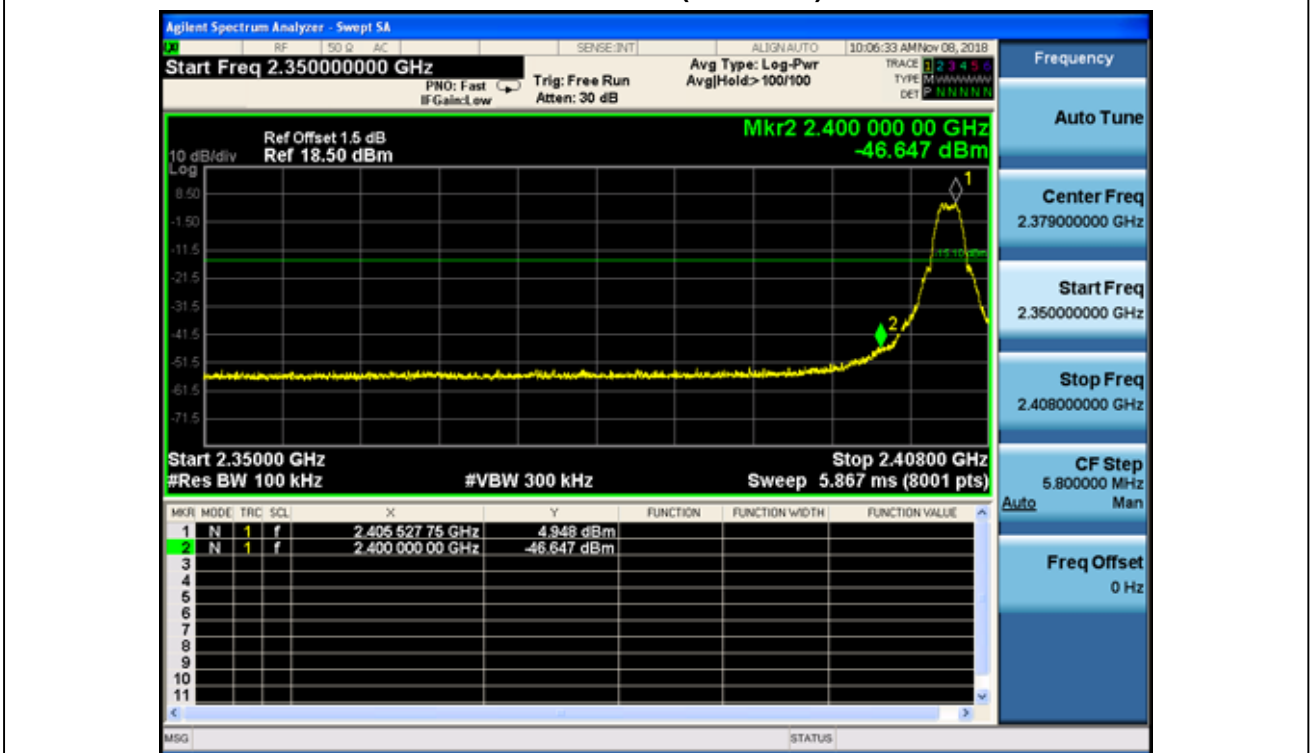

## 6. Radiated Emission Band Edge

### 6.1. Test Equipment

Radiated Emission(Above 1GHz) / AC-5					
Instrument	Manufacturer	Type No.	Serial No.	Cal. Date	Cal. Due Date
EMI Receiver	Agilent	N9038A	MY51210196	2018.07.16	2019.07.15
Pre-Amplifier	Miteq	NSP1800-25	1364185	2018.05.03	2019.05.02
DRG Horn Antenna	ETS-Lindgren	3117	00167055	2018.07.12	2019.07.11
Broad-Band Horn Antenna	Schwarzbeck	BBHA9170	294	2018.09.18	2019.09.17
Coaxial Cable	Huber+Suhner	SUCOFLEX 106	AC5-C1	2018.02.28	2019.02.27
Coaxial Cable	Huber+Suhner	SUCOFLEX 106	AC5-C2	2018.02.28	2019.02.27
Temperature/Humidity Meter	Zhichen	ZC1-2	AC5-TH	2018.01.05	2019.01.04

### 6.2. Test Setup

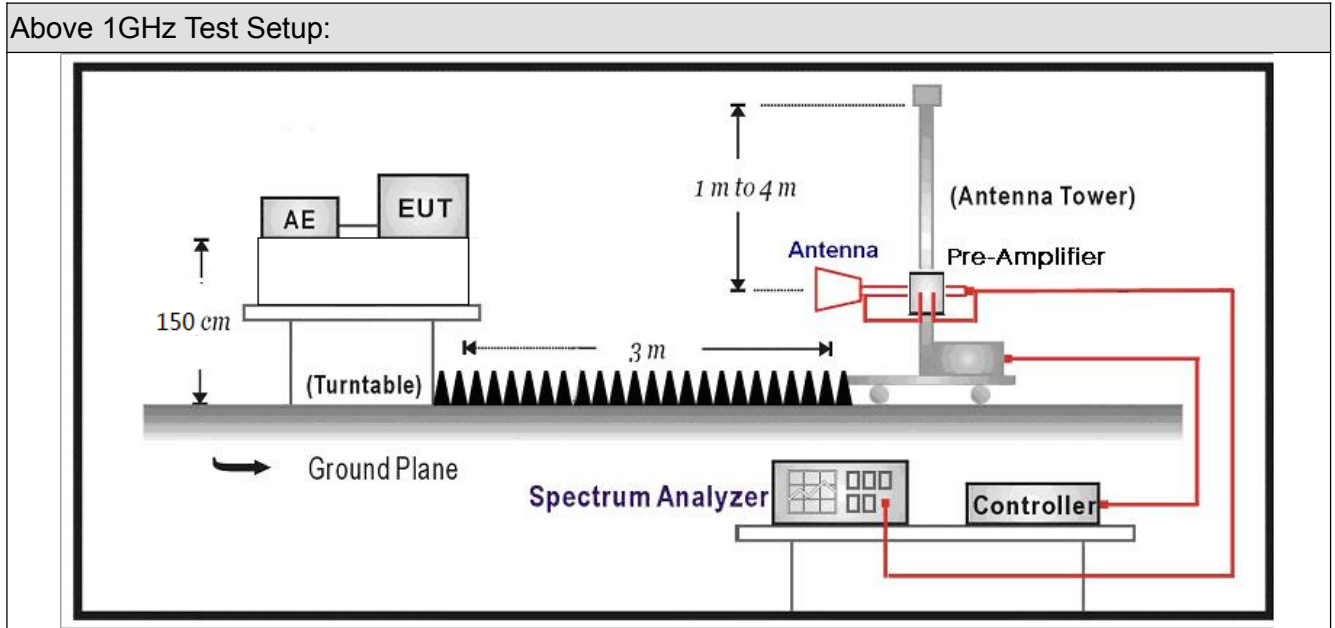

### 6.3. Limit





Band edge Limit				
Frequency bands (MHz)	Detector	Limit (dB $\mu$ V/m)	RBW (MHz)	Distance (m)
2310-2390	PK	74	1	3
2483.5-2500	AV	54	1	3

Note: The field strength of emissions appearing within these frequency bands shall not exceed the limits

### 6.4. Test Procedure

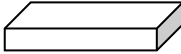
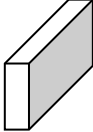
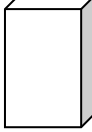
Test Method				
	References Rule		Chapter	Description
<input checked="" type="checkbox"/>	ANSI C63.10		6.10	Band-edge testing
	<input checked="" type="checkbox"/>	ANSI C63.10	6.10.5	Restricted-band band-edge measurements
	<input type="checkbox"/>	ANSI C63.10	6.10.6	Marker-delta method
<input checked="" type="checkbox"/>	ANSI C63.10		11.12	Emissions in restricted frequency bands
	<input checked="" type="checkbox"/>	ANSI C63.10	11.12.1	Radiated emission measurements
	<input checked="" type="checkbox"/>	ANSI C63.10	11.12.2.7	Radiated spurious emission test
<input type="checkbox"/>	ANSI C63.10		6.4	Radiated emissions from unlicensed wireless devices below 30 MHz
<input type="checkbox"/>	ANSI C63.10		6.5	Radiated emissions from unlicensed wireless devices in the frequency range of 30 MHz to 1000 MHz
<input checked="" type="checkbox"/>	ANSI C63.10		6.6	Radiated emissions from unlicensed wireless devices above 1 GHz
	<input type="checkbox"/>	ANSI C63.10	11.12.2.3	Quasi-peak measurement procedure
	<input checked="" type="checkbox"/>	ANSI C63.10	11.12.2.4	Peak power measurement procedure
	<input checked="" type="checkbox"/>	ANSI C63.10	11.12.2.5	Average power measurement procedures
	<input type="checkbox"/>	ANSI C63.10	11.12.2.5.1	Trace averaging with continuous EUT transmission at full power
	<input type="checkbox"/>	ANSI C63.10	11.12.2.5.2	Trace averaging across ON and OFF times of the EUT transmissions followed by duty cycle correction
	<input checked="" type="checkbox"/>	ANSI C63.10	11.12.2.5.3	Reduced VBW averaging across ON and OFF times of the EUT transmissions with max hold

**6.5. EUT test definition**

Item	Radiated Emission Band Edge			
Device Category	<input type="checkbox"/>	Fixed point-to-point		
	<input type="checkbox"/>	Emit multiple directional beams, simultaneously or sequentially		
	<input checked="" type="checkbox"/>	Other cases		
Test mode	Mode 1			
Test method	<input checked="" type="checkbox"/>	Radiated		
		X Axis	Y Axis	Z Axis
				
		Worst Axis <input checked="" type="checkbox"/>	Worst Axis <input type="checkbox"/>	Worst Axis <input type="checkbox"/>
	<input type="checkbox"/>	Conducted		
	<input type="checkbox"/>	Chain 0		
				
	<input type="checkbox"/>	Chain 0	Chain 1	
				
	<input type="checkbox"/>	Chain 0	Chain 1	Chain 2
				

### 6.6. Duty Cycle

Test Mode	Tx On (ms)	Tx Off (ms)	Reduced VBW (kHz)	Tx On + Tx Off (ms)	Duty Cycle
Zigbee	-	-	10Hz	-	100%

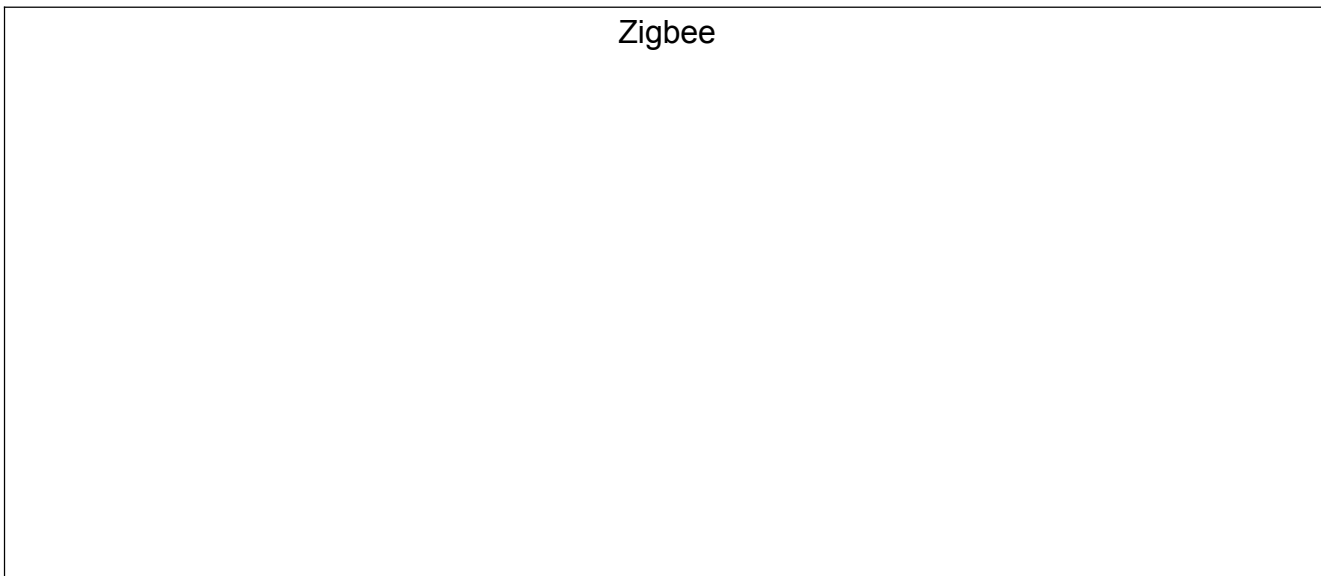

### 6.7 Test Result

#### LED lamp(Crystal oscillator: Diode (FL3840023)\_2017; Lighting source: LTN):

Engineer: Karl	
Site: AC5	Time: 2018/11/07 - 22:06
Limit: FCC_Part15.209_RE(3m)	Margin: 0
Probe: Horn_3117_00167055(1-18GHz)	Polarity: Horizontal
EUT: LED lamp	Power: AC 120V/60Hz
Note: Mode 1:Transmit at 2405MHz by Zigbee LTN	

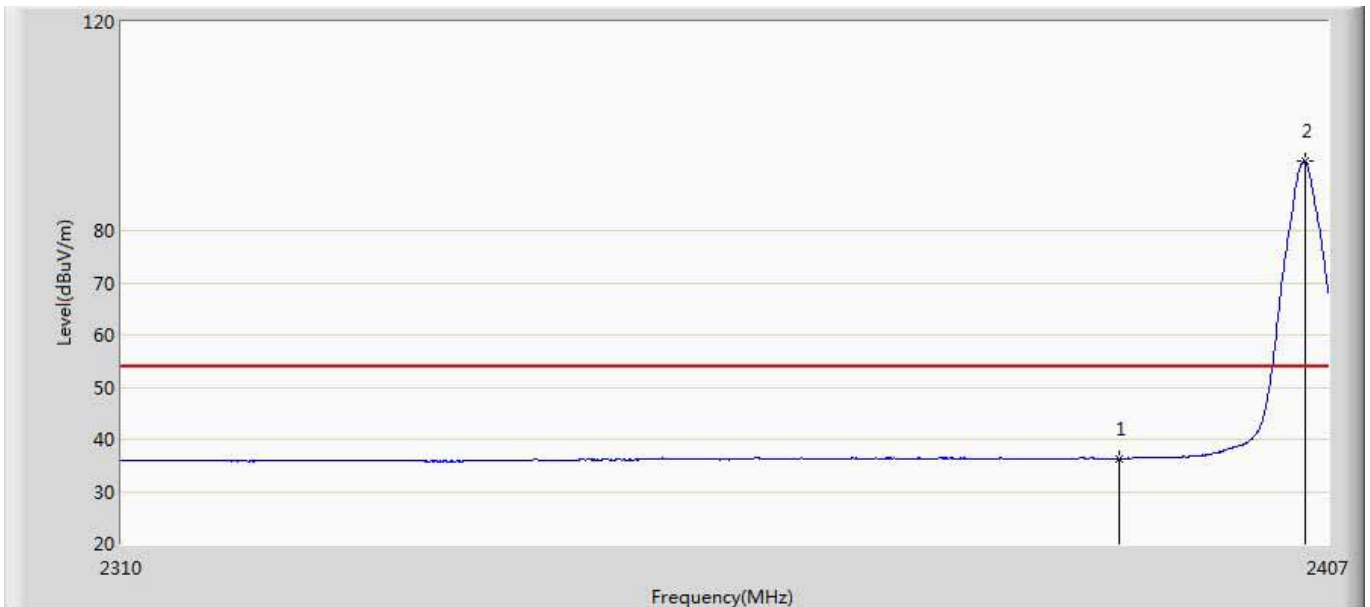

No	Mark	Frequency (MHz)	Measure Level (dBuV/m)	Reading Level (dBuV)	Over Limit (dB)	Limit (dBuV/m)	Factor (dB)	Type
1		2390.000	36.317	-0.107	-17.683	54.000	36.424	AV
2	*	2405.108	93.306	56.919	39.306	54.000	36.387	AV

Engineer: Karl	
Site: AC5	Time: 2018/11/07 - 22:11
Limit: FCC_Part15.209_RE(3m)	Margin: 0
Probe: Horn_3117_00167055(1-18GHz)	Polarity: Horizontal
EUT: LED lamp	Power: AC 120V/60Hz
Note: Mode 1:Transmit at 2405MHz by Zigbee LTN	

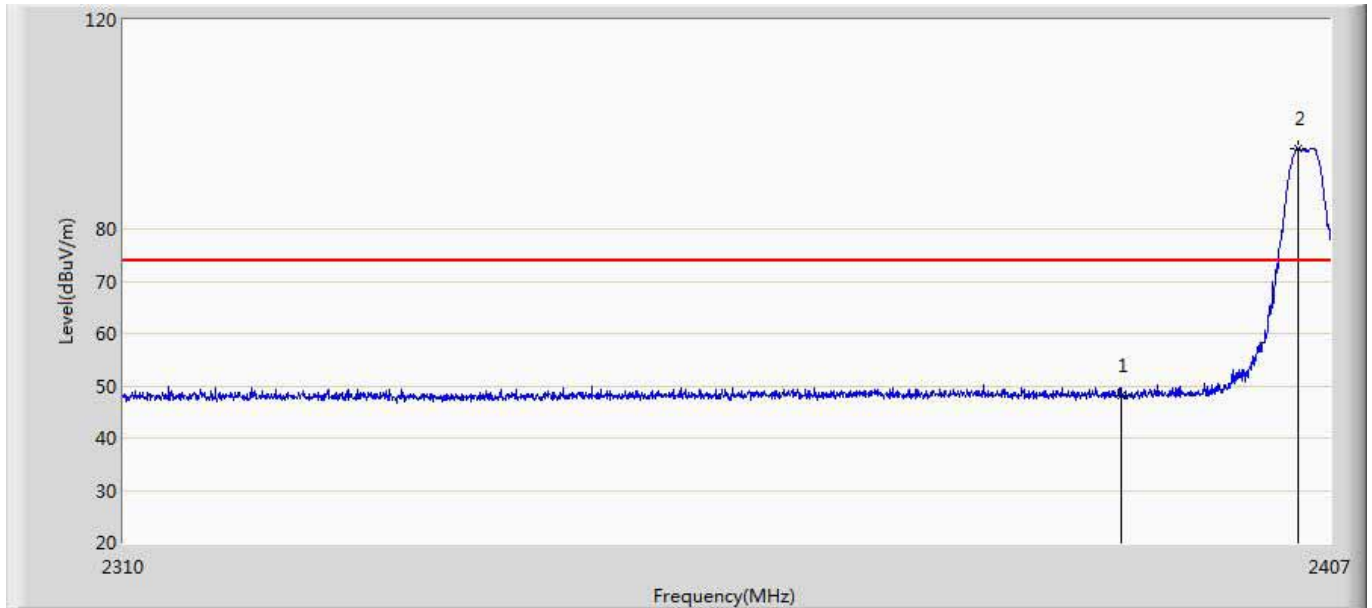

No	Mark	Frequency (MHz)	Measure Level (dBuV/m)	Reading Level (dBuV)	Over Limit (dB)	Limit (dBuV/m)	Factor (dB)	Type
1		2390.000	48.068	11.644	-25.932	74.000	36.424	PK
2	*	2404.381	95.317	58.928	21.317	74.000	36.389	PK



Engineer: Karl	
Site: AC5	Time: 2018/11/07 - 22:13
Limit: FCC_Part15.209_RE(3m)	Margin: 0
Probe: Horn_3117_00167055(1-18GHz)	Polarity: Vertical
EUT: LED lamp	Power: AC 120V/60Hz
Note: Mode 1:Transmit at 2405MHz by Zigbee LTN	

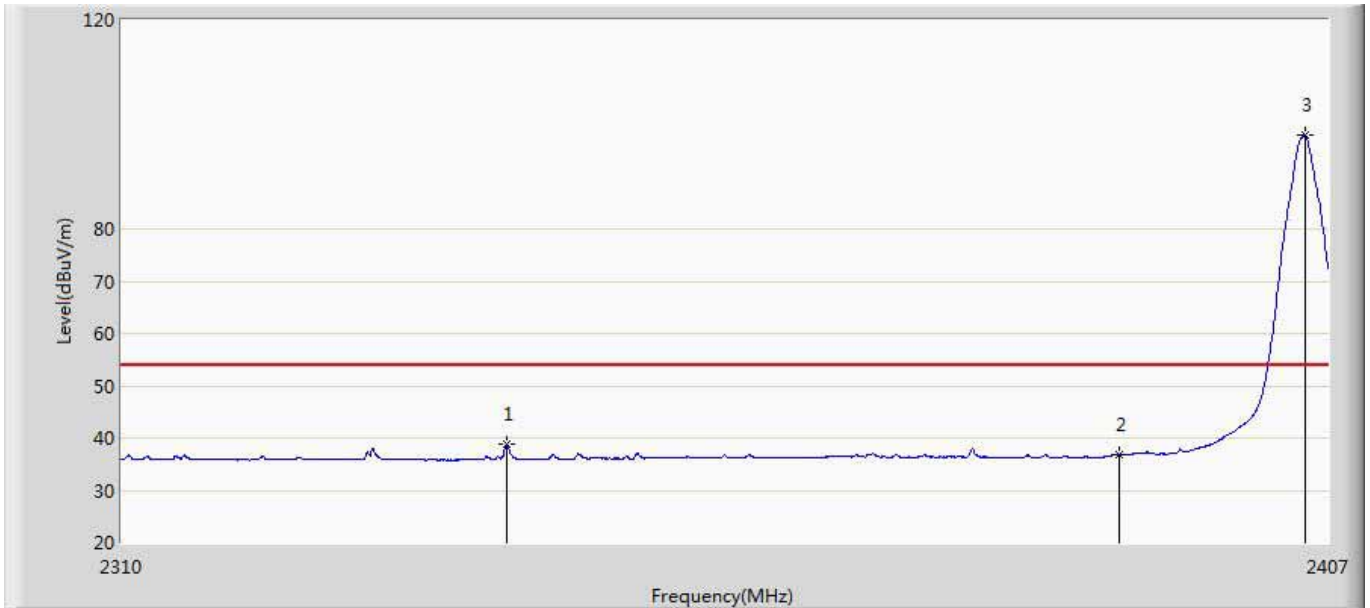

No	Mark	Frequency (MHz)	Measure Level (dBuV/m)	Reading Level (dBuV)	Over Limit (dB)	Limit (dBuV/m)	Factor (dB)	Type
1		2340.555	38.890	2.735	-15.110	54.000	36.155	AV
2		2390.000	36.833	0.409	-17.167	54.000	36.424	AV
3	*	2405.108	97.918	61.531	43.918	54.000	36.387	AV

Engineer: Karl	
Site: AC5	Time: 2018/11/07 - 22:15
Limit: FCC_Part15.209_RE(3m)	Margin: 0
Probe: Horn_3117_00167055(1-18GHz)	Polarity: Vertical
EUT: LED lamp	Power: AC 120V/60Hz
Note: Mode 1:Transmit at 2405MHz by Zigbee LTN	

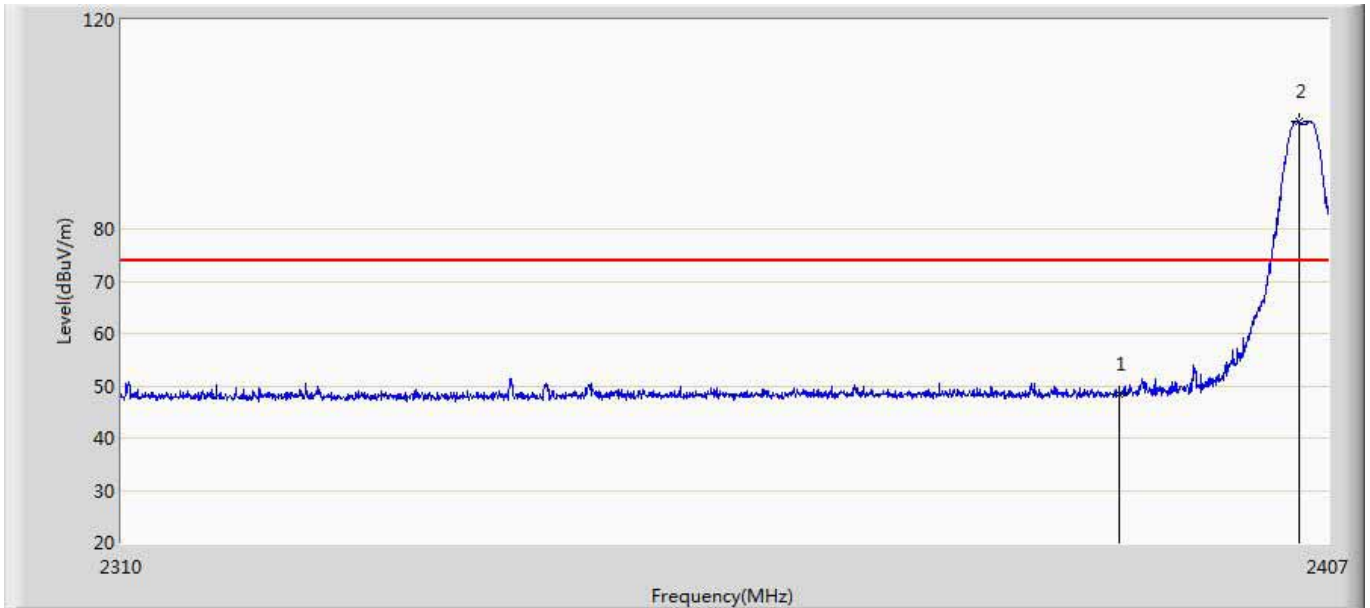

No	Mark	Frequency (MHz)	Measure Level (dBuV/m)	Reading Level (dBuV)	Over Limit (dB)	Limit (dBuV/m)	Factor (dB)	Type
1		2390.000	48.306	11.882	-25.694	74.000	36.424	PK
2	*	2404.624	100.486	64.098	26.486	74.000	36.388	PK

Engineer: Karl	
Site: AC5	Time: 2018/11/07 - 22:17
Limit: FCC_Part15.209_RE(3m)	Margin: 0
Probe: Horn_3117_00167055(1-18GHz)	Polarity: Horizontal
EUT: LED lamp	Power: AC 120V/60Hz
Note: Mode 1:Transmit at 2480MHz by Zigbee LTN	

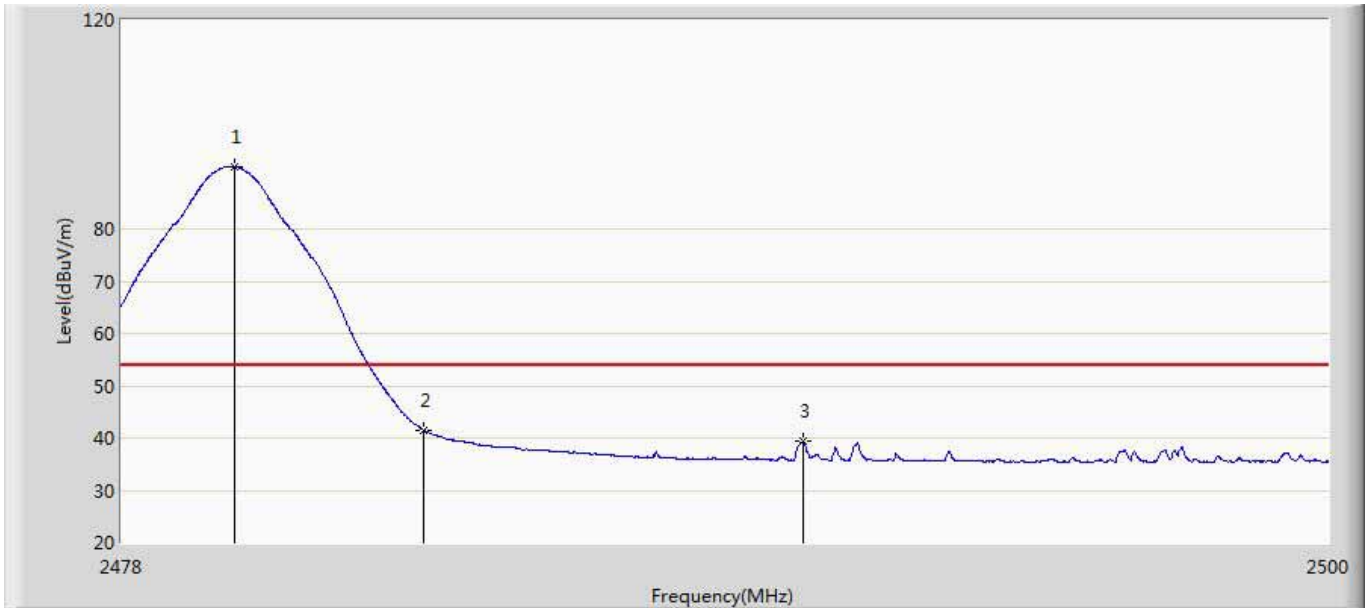

No	Mark	Frequency (MHz)	Measure Level (dBuV/m)	Reading Level (dBuV)	Over Limit (dB)	Limit (dBuV/m)	Factor (dB)	Type
1	*	2480.046	91.942	55.302	37.942	54.000	36.640	AV
2		2483.500	41.481	4.835	-12.519	54.000	36.646	AV
3		2490.408	39.419	2.760	-14.581	54.000	36.659	AV

Engineer: Karl	
Site: AC5	Time: 2018/11/07 - 22:20
Limit: FCC_Part15.209_RE(3m)	Margin: 0
Probe: Horn_3117_00167055(1-18GHz)	Polarity: Horizontal
EUT: LED lamp	Power: AC 120V/60Hz
Note: Mode 1:Transmit at 2480MHz by Zigbee LTN	

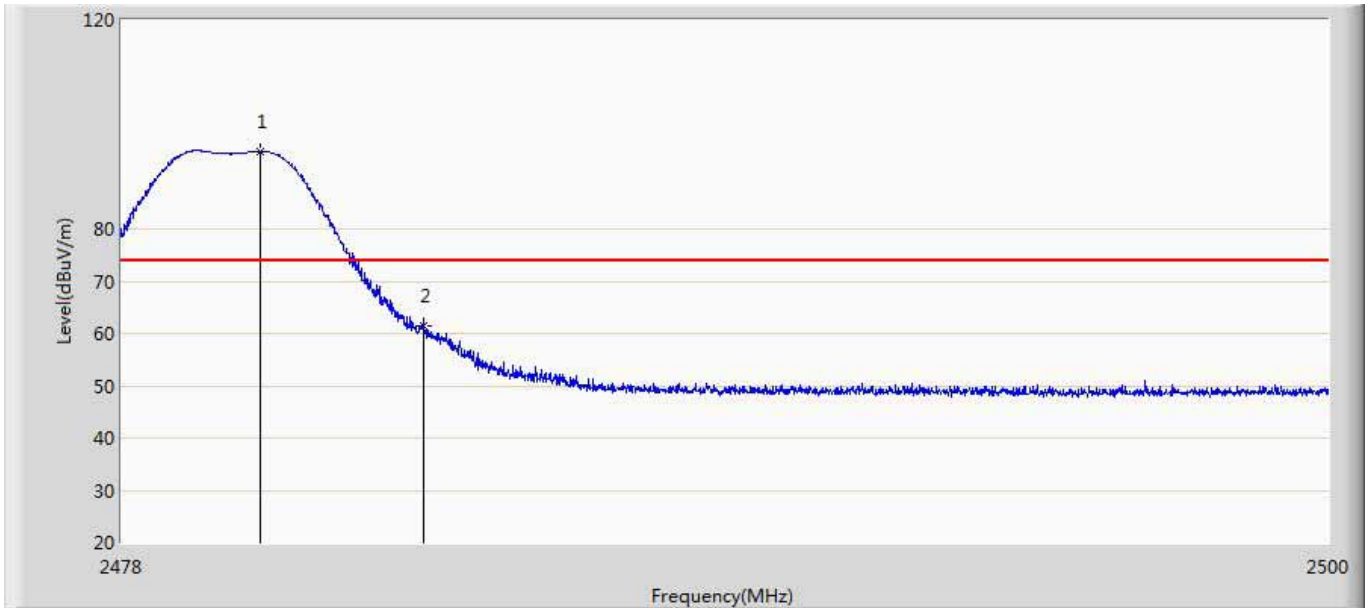

No	Mark	Frequency (MHz)	Measure Level (dBuV/m)	Reading Level (dBuV)	Over Limit (dB)	Limit (dBuV/m)	Factor (dB)	Type
1	*	2480.530	94.805	58.164	20.805	74.000	36.641	PK
2		2483.500	61.460	24.814	-12.540	74.000	36.646	PK

Engineer: Karl	
Site: AC5	Time: 2018/11/07 - 22:22
Limit: FCC_Part15.209_RE(3m)	Margin: 0
Probe: Horn_3117_00167055(1-18GHz)	Polarity: Vertical
EUT: LED lamp	Power: AC 120V/60Hz
Note: Mode 1:Transmit at 2480MHz by Zigbee LTN	

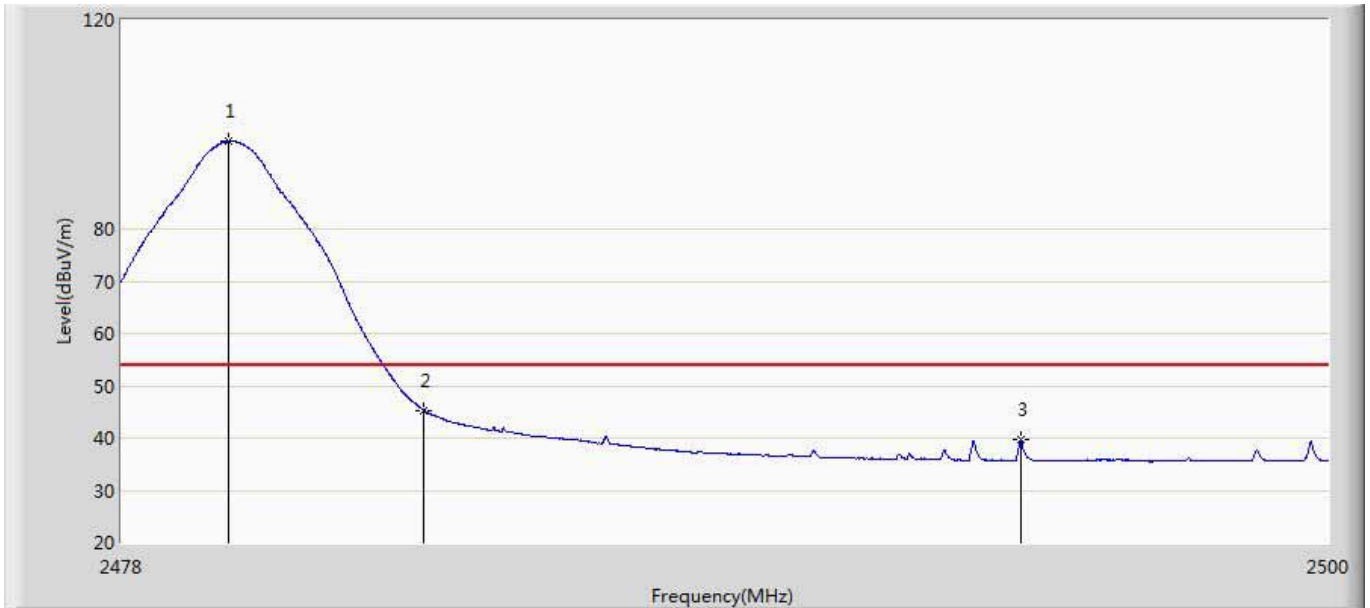

No	Mark	Frequency (MHz)	Measure Level (dBuV/m)	Reading Level (dBuV)	Over Limit (dB)	Limit (dBuV/m)	Factor (dB)	Type
1	*	2479.947	96.791	60.151	42.791	54.000	36.640	AV
2		2483.500	45.308	8.662	-8.692	54.000	36.646	AV
3		2494.379	39.589	2.922	-14.411	54.000	36.667	AV

Engineer: Karl	
Site: AC5	Time: 2018/11/07 - 22:24
Limit: FCC_Part15.209_RE(3m)	Margin: 0
Probe: Horn_3117_00167055(1-18GHz)	Polarity: Vertical
EUT: LED lamp	Power: AC 120V/60Hz
Note: Mode 1:Transmit at 2480MHz by Zigbee LTN	

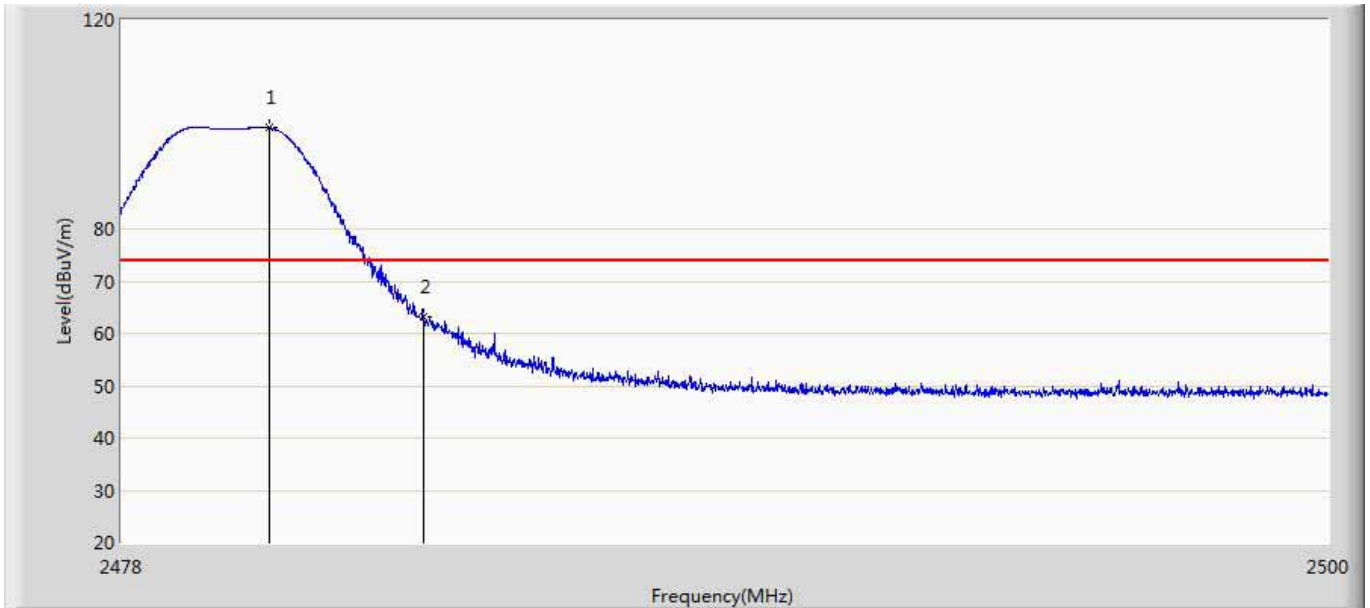

No	Mark	Frequency (MHz)	Measure Level (dBuV/m)	Reading Level (dBuV)	Over Limit (dB)	Limit (dBuV/m)	Factor (dB)	Type
1	*	2480.695	99.388	62.747	25.388	74.000	36.641	PK
2		2483.500	63.262	26.616	-10.738	74.000	36.646	PK

**LED lamp (Crystal oscillator: Diode (FL3840023)\_2017; Lighting source: APT)**

Engineer: Karl	
Site: AC5	Time: 2018/11/07 - 22:26
Limit: FCC_Part15.209_RE(3m)	Margin: 0
Probe: Horn_3117_00167055(1-18GHz)	Polarity: Horizontal
EUT: LED lamp	Power: AC 120V/60Hz
Note: Mode 1:Transmit at 2405MHz by Zigbee APT	

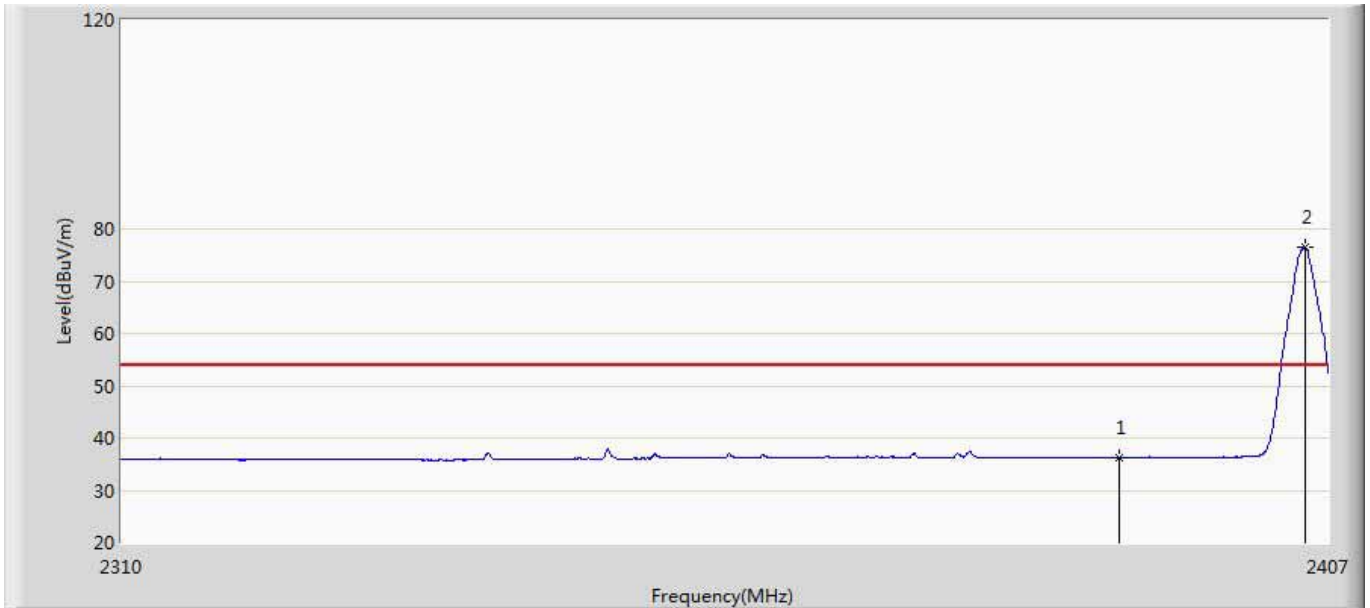

No	Mark	Frequency (MHz)	Measure Level (dBuV/m)	Reading Level (dBuV)	Over Limit (dB)	Limit (dBuV/m)	Factor (dB)	Type
1		2390.000	36.209	-0.215	-17.791	54.000	36.424	AV
2	*	2405.108	76.558	40.171	22.558	54.000	36.387	AV

Engineer: Karl	
Site: AC5	Time: 2018/11/07 - 22:29
Limit: FCC_Part15.209_RE(3m)	Margin: 0
Probe: Horn_3117_00167055(1-18GHz)	Polarity: Horizontal
EUT: LED lamp	Power: AC 120V/60Hz
Note: Mode 1:Transmit at 2405MHz by Zigbee APT	

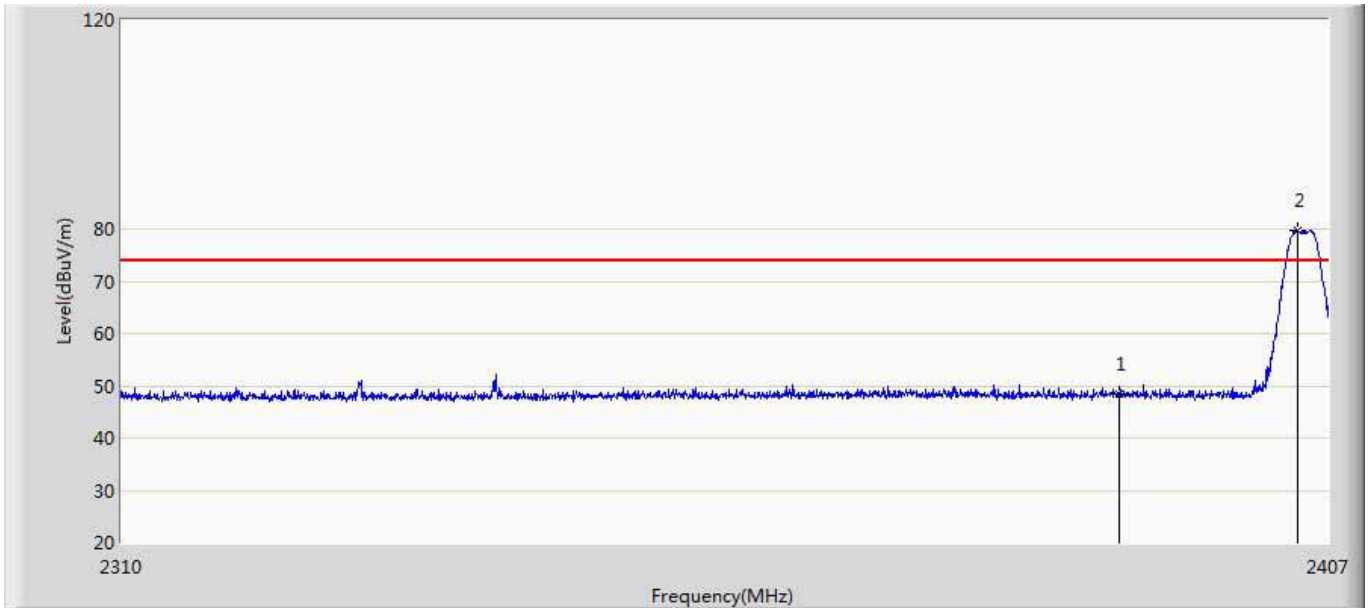

No	Mark	Frequency (MHz)	Measure Level (dBuV/m)	Reading Level (dBuV)	Over Limit (dB)	Limit (dBuV/m)	Factor (dB)	Type
1		2390.000	48.376	11.952	-25.624	74.000	36.424	PK
2	*	2404.478	79.624	43.235	5.624	74.000	36.388	PK



Engineer: Karl	
Site: AC5	Time: 2018/11/07 - 22:33
Limit: FCC_Part15.209_RE(3m)	Margin: 0
Probe: Horn_3117_00167055(1-18GHz)	Polarity: Vertical
EUT: LED lamp	Power: AC 120V/60Hz
Note: Mode 1:Transmit at 2405MHz by Zigbee APT	

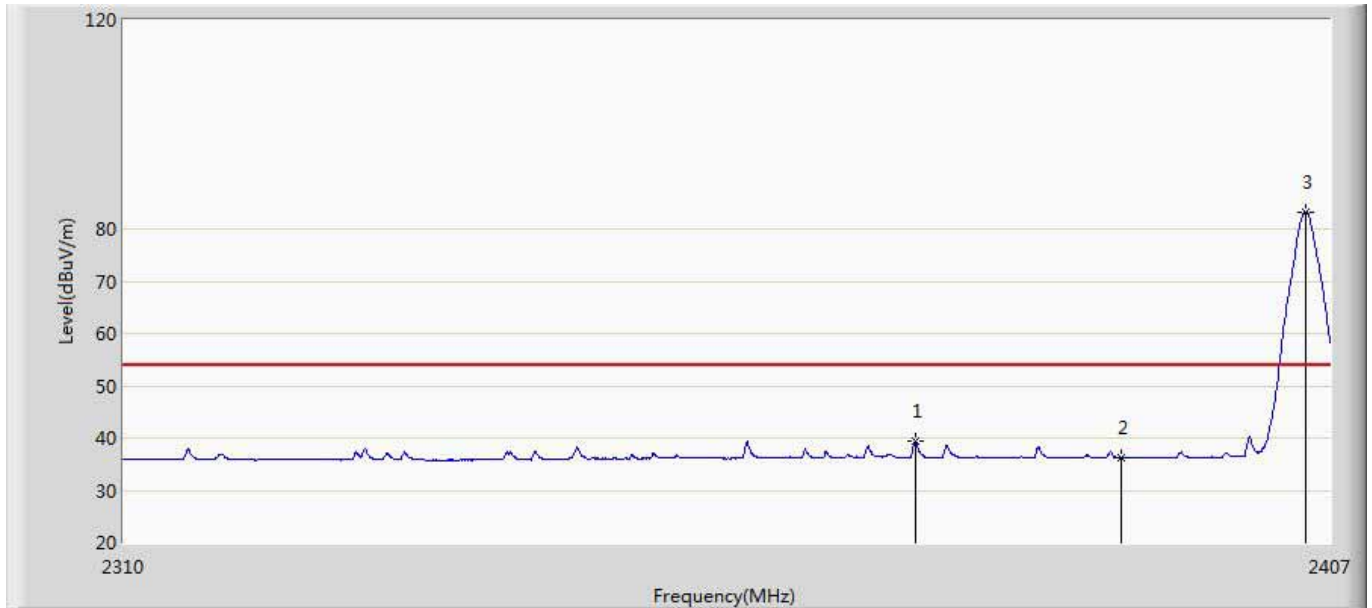

No	Mark	Frequency (MHz)	Measure Level (dBuV/m)	Reading Level (dBuV)	Over Limit (dB)	Limit (dBuV/m)	Factor (dB)	Type
1		2373.244	39.408	2.954	-14.592	54.000	36.454	AV
2		2390.000	36.203	-0.221	-17.797	54.000	36.424	AV
3	*	2405.011	83.203	46.816	29.203	54.000	36.387	AV

Engineer: Karl	
Site: AC5	Time: 2018/11/07 - 22:35
Limit: FCC_Part15.209_RE(3m)	Margin: 0
Probe: Horn_3117_00167055(1-18GHz)	Polarity: Vertical
EUT: LED lamp	Power: AC 120V/60Hz
Note: Mode 1:Transmit at 2405MHz by Zigbee APT	

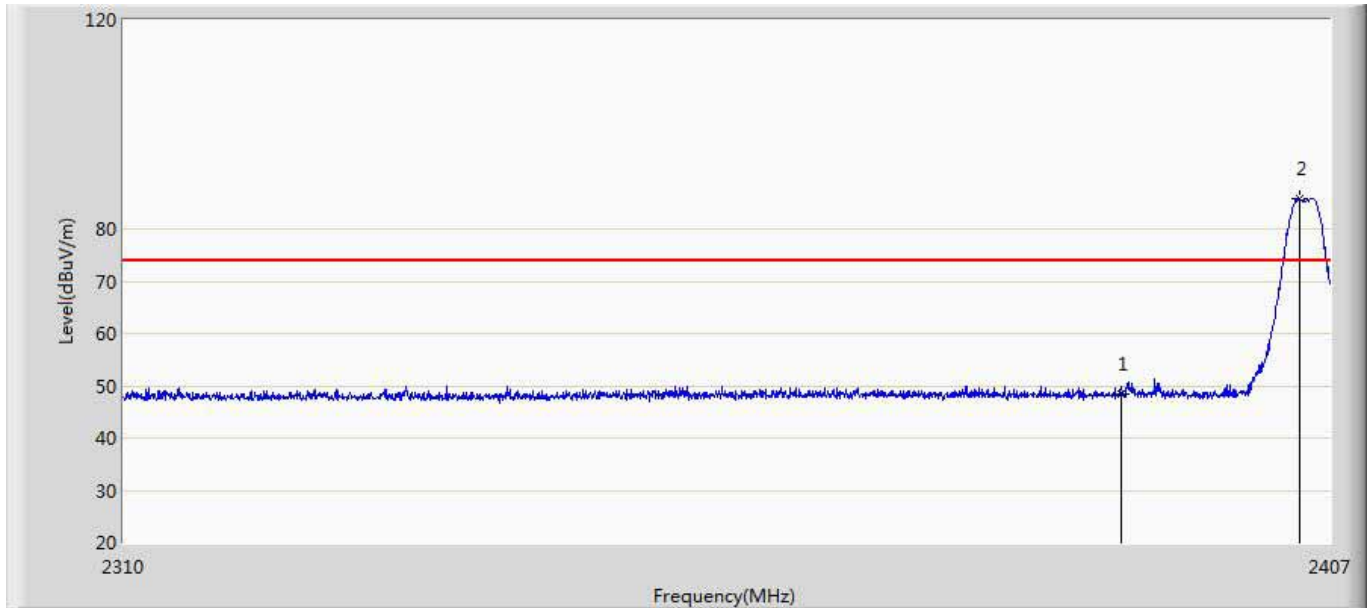

No	Mark	Frequency (MHz)	Measure Level (dBuV/m)	Reading Level (dBuV)	Over Limit (dB)	Limit (dBuV/m)	Factor (dB)	Type
1		2390.000	48.262	11.838	-25.738	74.000	36.424	PK
2	*	2404.478	85.803	49.414	11.803	74.000	36.388	PK

Engineer: Karl	
Site: AC5	Time: 2018/11/07 - 22:37
Limit: FCC_Part15.209_RE(3m)	Margin: 0
Probe: Horn_3117_00167055(1-18GHz)	Polarity: Horizontal
EUT: LED lamp	Power: AC 120V/60Hz
Note: Mode 1:Transmit at 2480MHz by Zigbee APT	

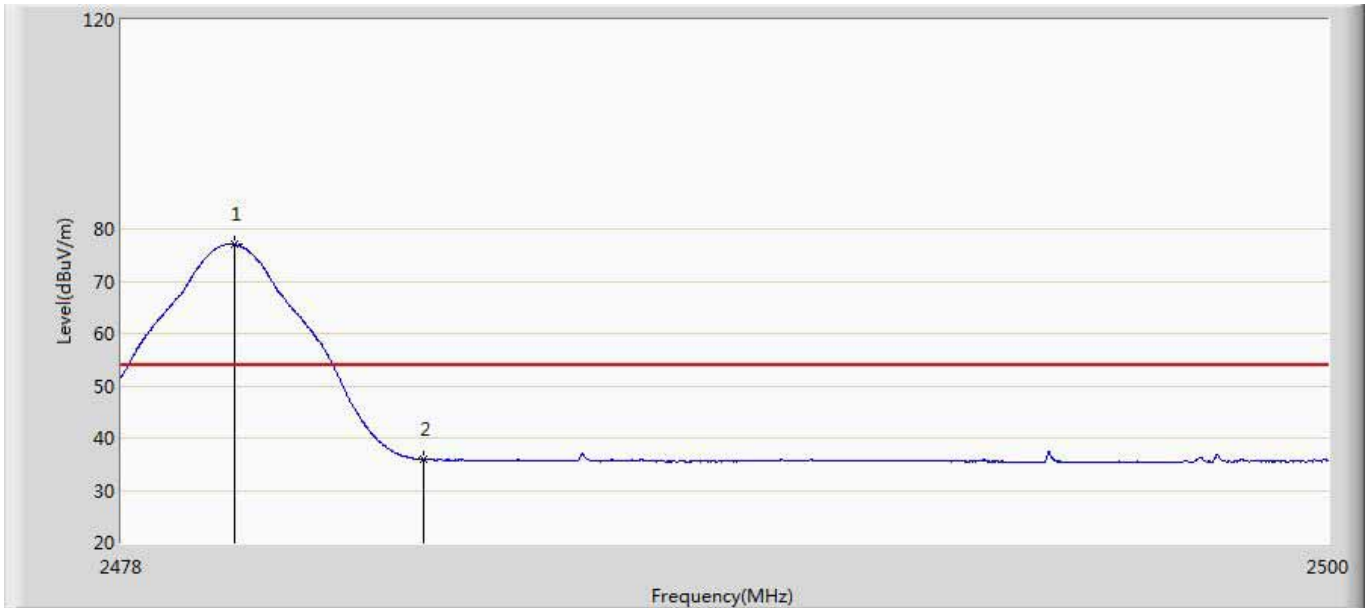

No	Mark	Frequency (MHz)	Measure Level (dBuV/m)	Reading Level (dBuV)	Over Limit (dB)	Limit (dBuV/m)	Factor (dB)	Type
1	*	2480.046	77.044	40.404	23.044	54.000	36.640	AV
2		2483.500	35.964	-0.682	-18.036	54.000	36.646	AV

Engineer: Karl	
Site: AC5	Time: 2018/11/07 - 22:41
Limit: FCC_Part15.209_RE(3m)	Margin: 0
Probe: Horn_3117_00167055(1-18GHz)	Polarity: Horizontal
EUT: LED lamp	Power: AC 120V/60Hz
Note: Mode 1:Transmit at 2480MHz by Zigbee APT	

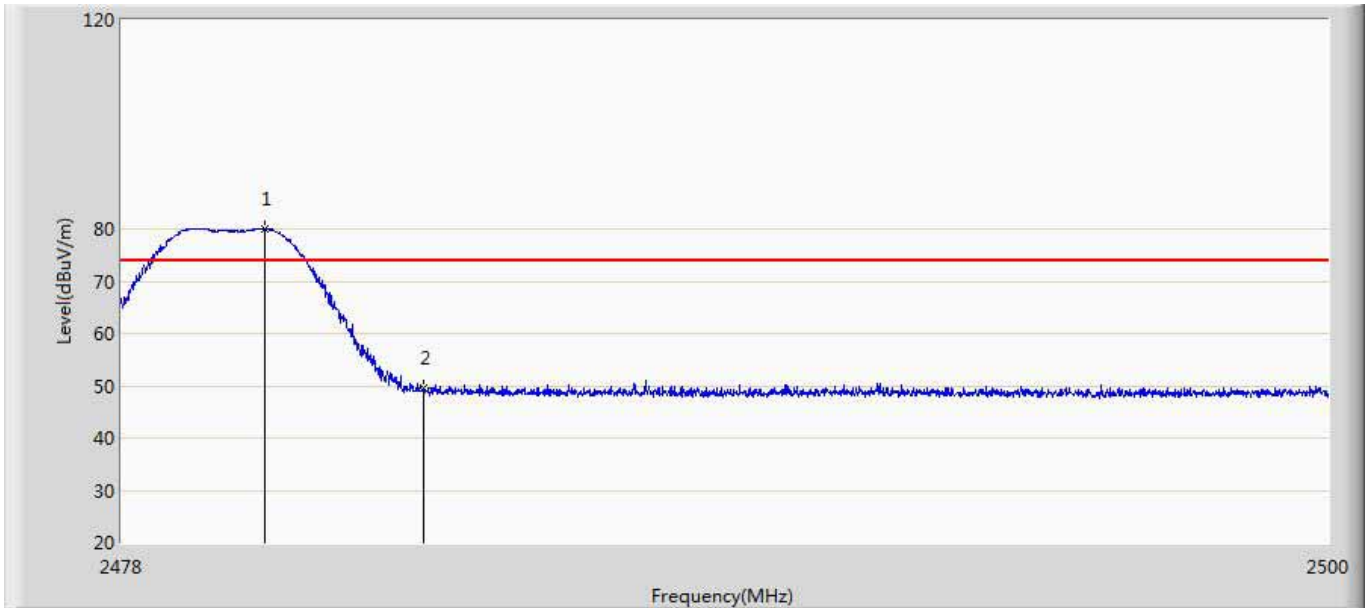

No	Mark	Frequency (MHz)	Measure Level (dBuV/m)	Reading Level (dBuV)	Over Limit (dB)	Limit (dBuV/m)	Factor (dB)	Type
1	*	2480.596	79.922	43.281	5.922	74.000	36.641	PK
2		2483.500	49.504	12.858	-24.496	74.000	36.646	PK

Engineer: Karl	
Site: AC5	Time: 2018/11/07 - 22:44
Limit: FCC_Part15.209_RE(3m)	Margin: 0
Probe: Horn_3117_00167055(1-18GHz)	Polarity: Vertical
EUT: LED lamp	Power: AC 120V/60Hz
Note: Mode 1:Transmit at 2480MHz by Zigbee APT	

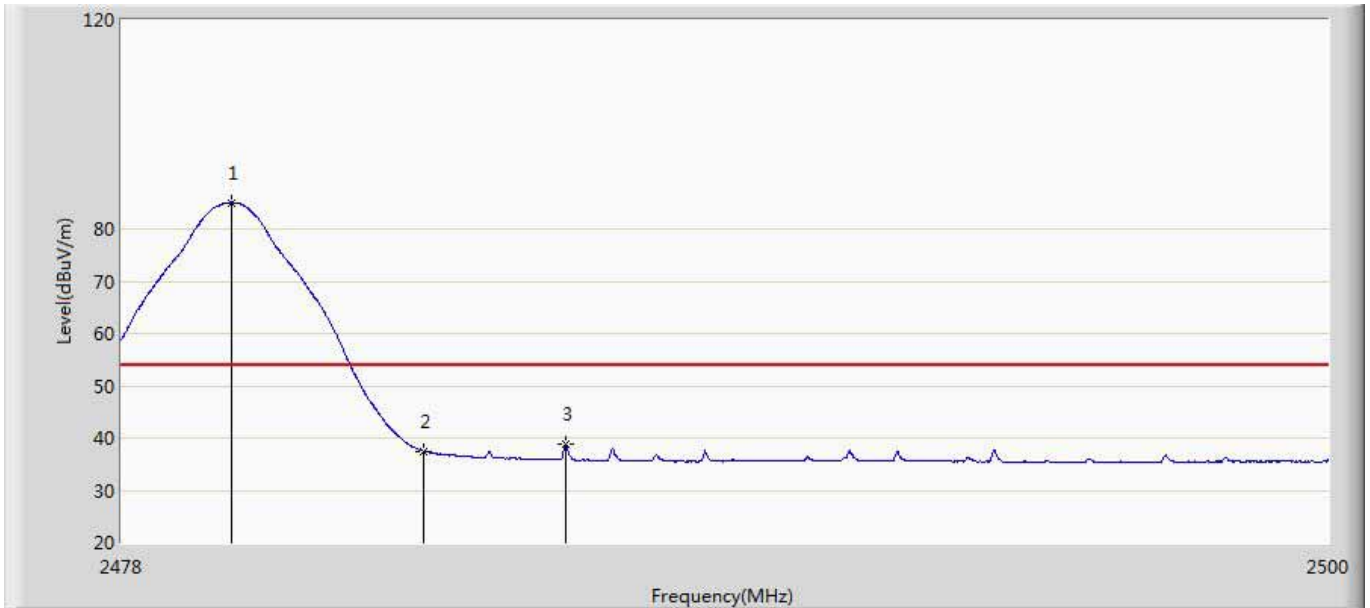

No	Mark	Frequency (MHz)	Measure Level (dBuV/m)	Reading Level (dBuV)	Over Limit (dB)	Limit (dBuV/m)	Factor (dB)	Type
1	*	2480.013	85.063	48.423	31.063	54.000	36.640	AV
2		2483.500	37.495	0.849	-16.505	54.000	36.646	AV
3		2486.085	38.830	2.179	-15.170	54.000	36.651	AV

Engineer: Karl	
Site: AC5	Time: 2018/11/07 - 22:47
Limit: FCC_Part15.209_RE(3m)	Margin: 0
Probe: Horn_3117_00167055(1-18GHz)	Polarity: Vertical
EUT: LED lamp	Power: AC 120V/60Hz
Note: Mode 1:Transmit at 2480MHz by Zigbee APT	

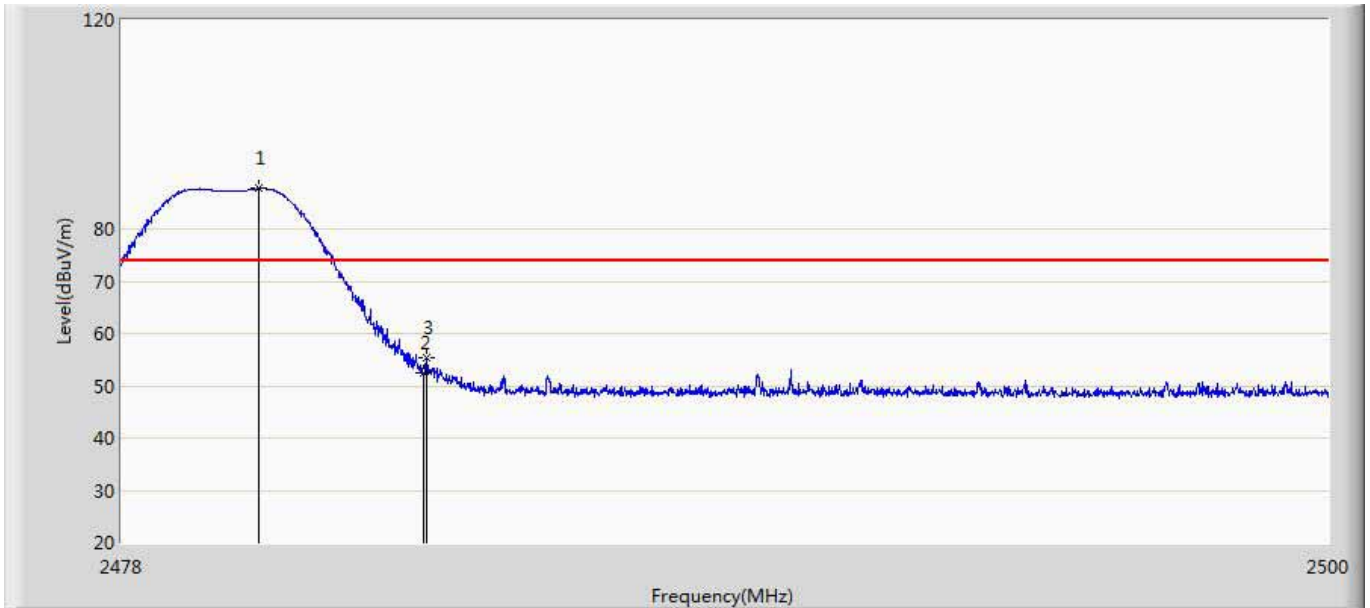

No	Mark	Frequency (MHz)	Measure Level (dBuV/m)	Reading Level (dBuV)	Over Limit (dB)	Limit (dBuV/m)	Factor (dB)	Type
1	*	2480.497	87.684	51.043	13.684	74.000	36.641	PK
2		2483.500	52.397	15.751	-21.603	74.000	36.646	PK
3		2483.555	55.257	18.610	-18.743	74.000	36.646	PK

**LED lamp (Crystal oscillator: Murata(XRCGB38M400FXH17R0)):**

Engineer: Karl	
Site: AC5	Time: 2018/11/09 - 21:19
Limit: FCC_Part15.209_RE(3m)	Margin: 0
Probe: Horn_3117_00167055(1-18GHz)	Polarity: Horizontal
EUT: LED lamp	Power: AC 120V/60Hz
Note: Mode 1:Transmit at 2405MHz by Zigbee	

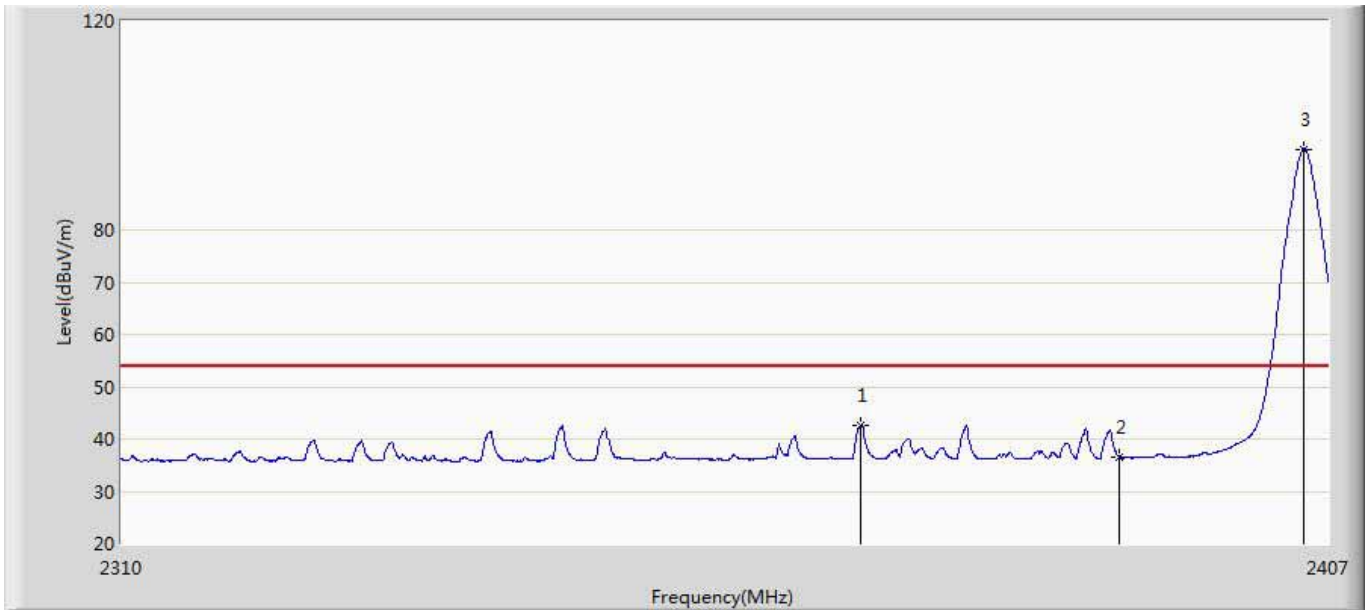

No	Mark	Frequency (MHz)	Measure Level (dBuV/m)	Reading Level (dBuV)	Over Limit (dB)	Limit (dBuV/m)	Factor (dB)	Type
1		2369.024	42.630	6.185	-11.370	54.000	36.445	AV
2		2390.000	36.435	0.011	-17.565	54.000	36.424	AV
3	*	2404.963	95.442	59.055	41.442	54.000	36.388	AV

Engineer: Karl	
Site: AC5	Time: 2018/11/09 - 21:22
Limit: FCC_Part15.209_RE(3m)	Margin: 0
Probe: Horn_3117_00167055(1-18GHz)	Polarity: Horizontal
EUT: LED lamp	Power: AC 120V/60Hz
Note: Mode 1:Transmit at 2405MHz by Zigbee	

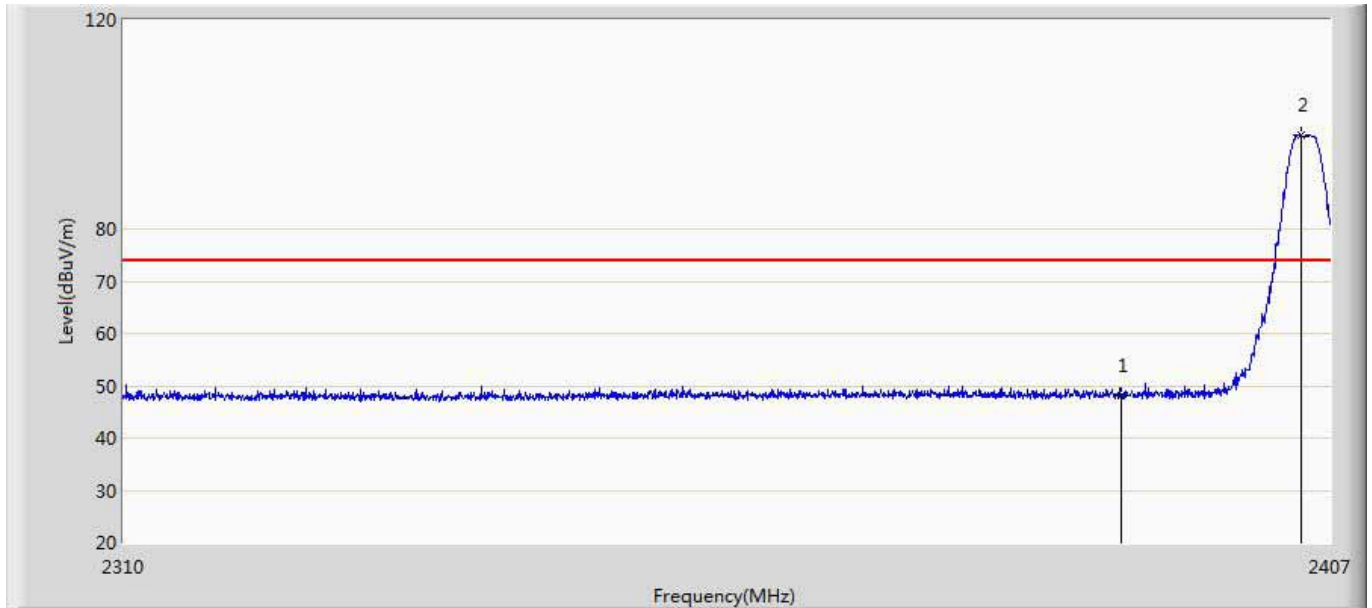

No	Mark	Frequency (MHz)	Measure Level (dBuV/m)	Reading Level (dBuV)	Over Limit (dB)	Limit (dBuV/m)	Factor (dB)	Type
1		2390.000	48.167	11.743	-25.833	74.000	36.424	PK
2	*	2404.624	97.861	61.473	23.861	74.000	36.388	PK



Engineer: Karl	
Site: AC5	Time: 2018/11/09 - 21:24
Limit: FCC_Part15.209_RE(3m)	Margin: 0
Probe: Horn_3117_00167055(1-18GHz)	Polarity: Vertical
EUT: LED lamp	Power: AC 120V/60Hz
Note: Mode 1:Transmit at 2405MHz by Zigbee	

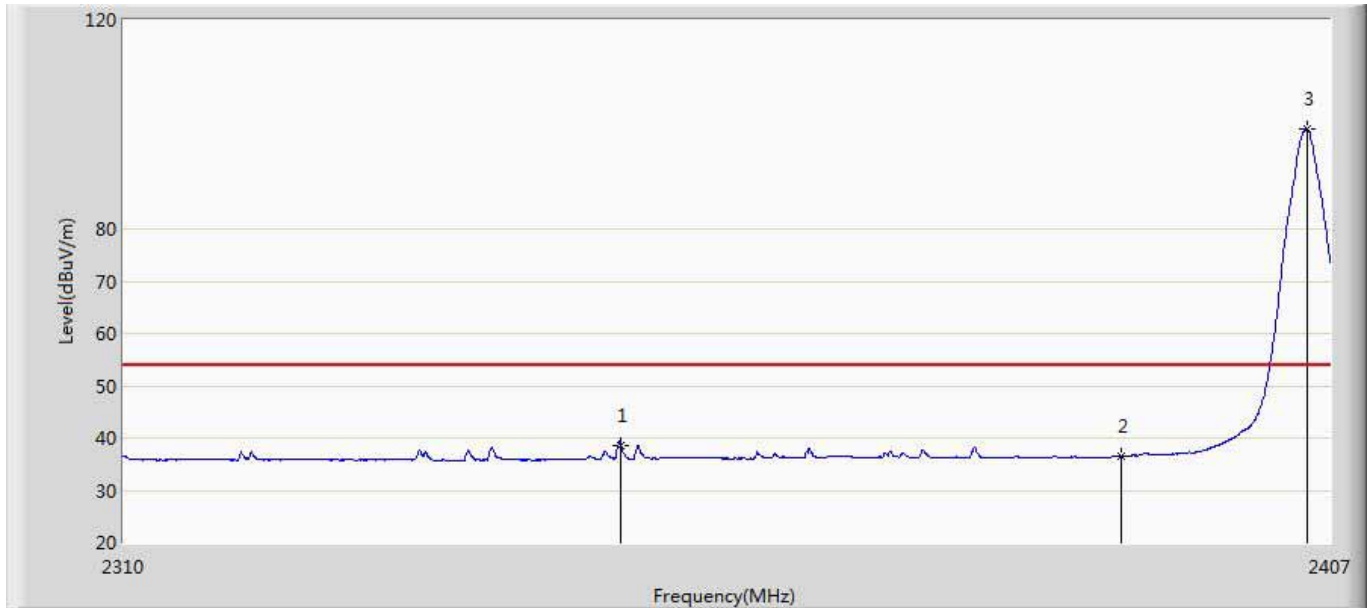

No	Mark	Frequency (MHz)	Measure Level (dBuV/m)	Reading Level (dBuV)	Over Limit (dB)	Limit (dBuV/m)	Factor (dB)	Type
1		2349.528	38.612	2.351	-15.388	54.000	36.261	AV
2		2390.000	36.515	0.091	-17.485	54.000	36.424	AV
3	*	2405.108	99.162	62.775	45.162	54.000	36.387	AV

Engineer: Karl	
Site: AC5	Time: 2018/11/09 - 21:26
Limit: FCC_Part15.209_RE(3m)	Margin: 0
Probe: Horn_3117_00167055(1-18GHz)	Polarity: Vertical
EUT: LED lamp	Power: AC 120V/60Hz
Note: Mode 1:Transmit at 2405MHz by Zigbee	

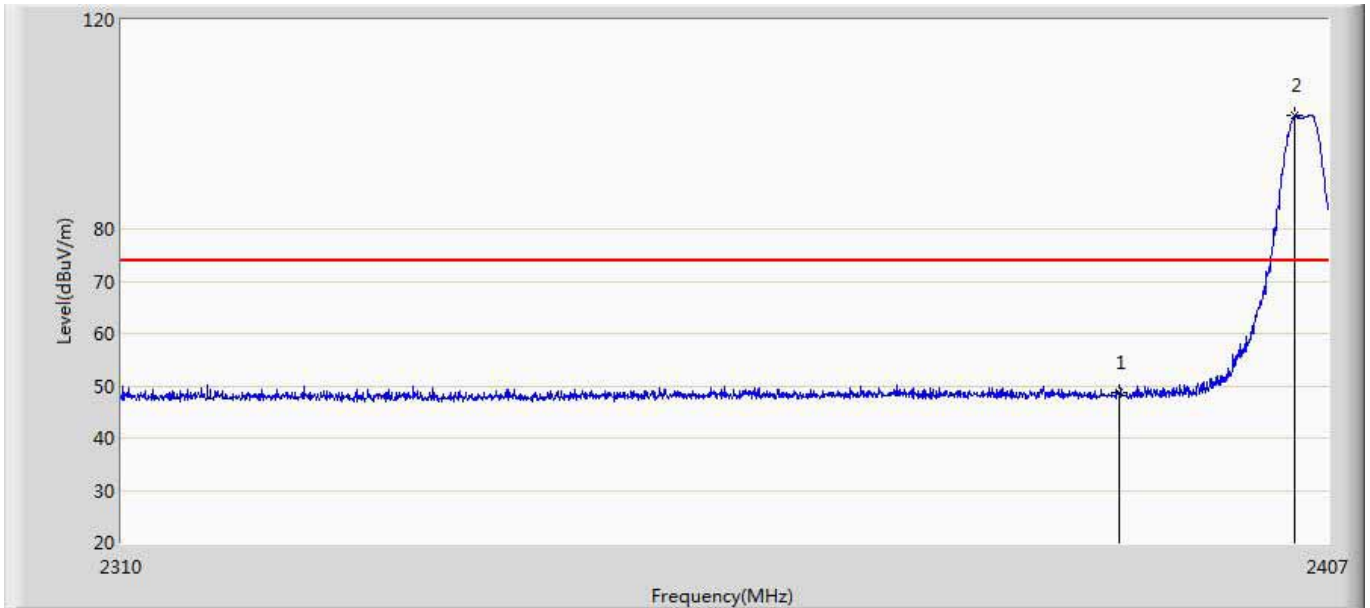

No	Mark	Frequency (MHz)	Measure Level (dBuV/m)	Reading Level (dBuV)	Over Limit (dB)	Limit (dBuV/m)	Factor (dB)	Type
1		2390.000	48.611	12.187	-25.389	74.000	36.424	PK
2	*	2404.333	101.626	65.237	27.626	74.000	36.389	PK

Engineer: Karl	
Site: AC5	Time: 2018/11/09 - 21:28
Limit: FCC_Part15.209_RE(3m)	Margin: 0
Probe: Horn_3117_00167055(1-18GHz)	Polarity: Horizontal
EUT: LED lamp	Power: AC 120V/60Hz
Note: Mode 1:Transmit at 2480MHz by Zigbee	

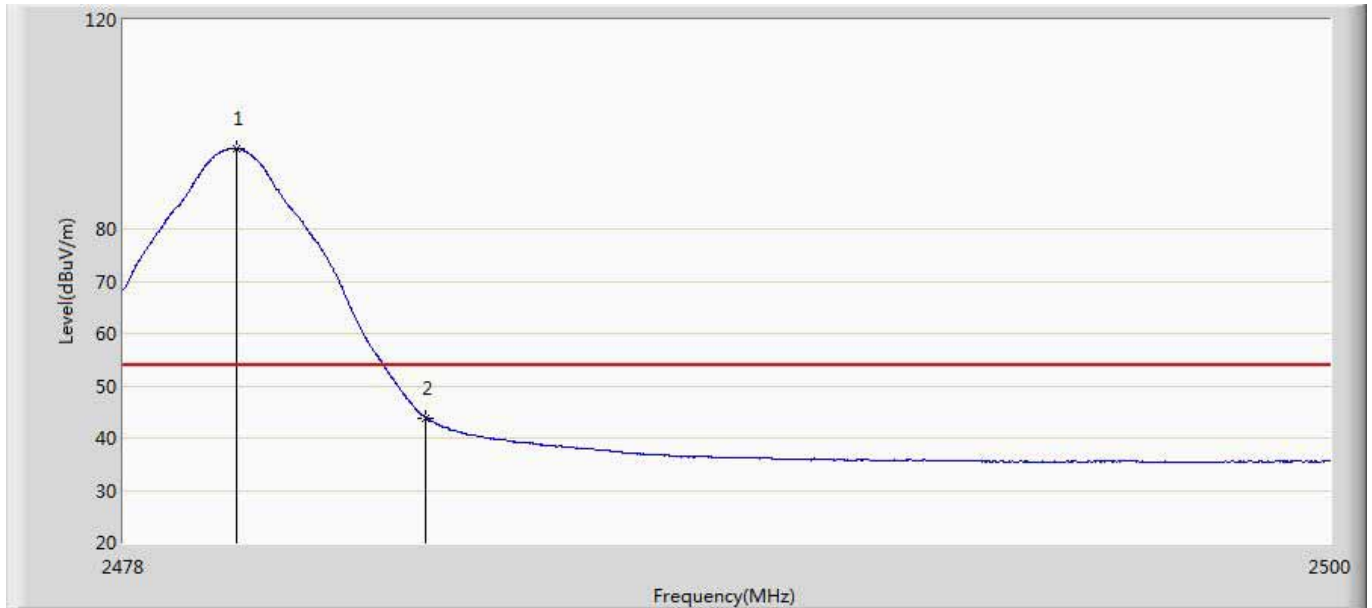

No	Mark	Frequency (MHz)	Measure Level (dBuV/m)	Reading Level (dBuV)	Over Limit (dB)	Limit (dBuV/m)	Factor (dB)	Type
1	*	2480.046	95.393	58.753	41.393	54.000	36.640	AV
2		2483.500	43.903	7.257	-10.097	54.000	36.646	AV

Engineer: Karl	
Site: AC5	Time: 2018/11/09 - 21:31
Limit: FCC_Part15.209_RE(3m)	Margin: 0
Probe: Horn_3117_00167055(1-18GHz)	Polarity: Horizontal
EUT: LED lamp	Power: AC 120V/60Hz
Note: Mode 1:Transmit at 2480MHz by Zigbee	

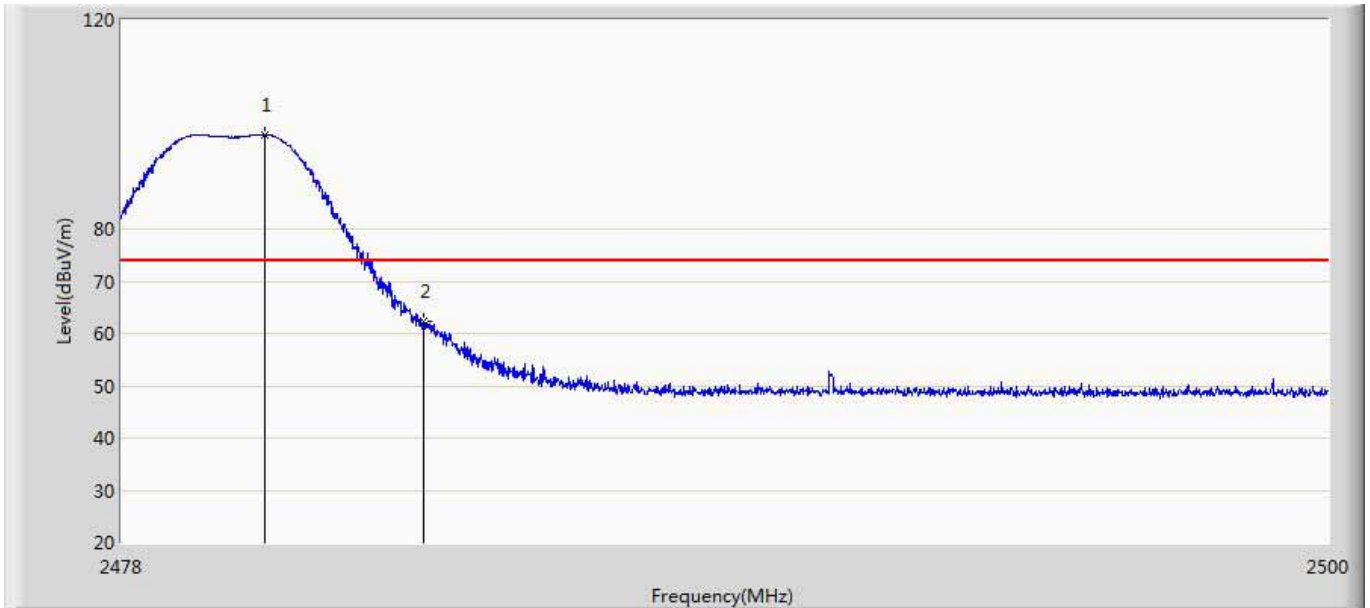

No	Mark	Frequency (MHz)	Measure Level (dBuV/m)	Reading Level (dBuV)	Over Limit (dB)	Limit (dBuV/m)	Factor (dB)	Type
1	*	2480.596	98.061	61.420	24.061	74.000	36.641	PK
2		2483.500	62.304	25.658	-11.696	74.000	36.646	PK

Engineer: Karl	
Site: AC5	Time: 2018/11/09 - 21:33
Limit: FCC_Part15.209_RE(3m)	Margin: 0
Probe: Horn_3117_00167055(1-18GHz)	Polarity: Vertical
EUT: LED lamp	Power: AC 120V/60Hz
Note: Mode 1:Transmit at 2480MHz by Zigbee	

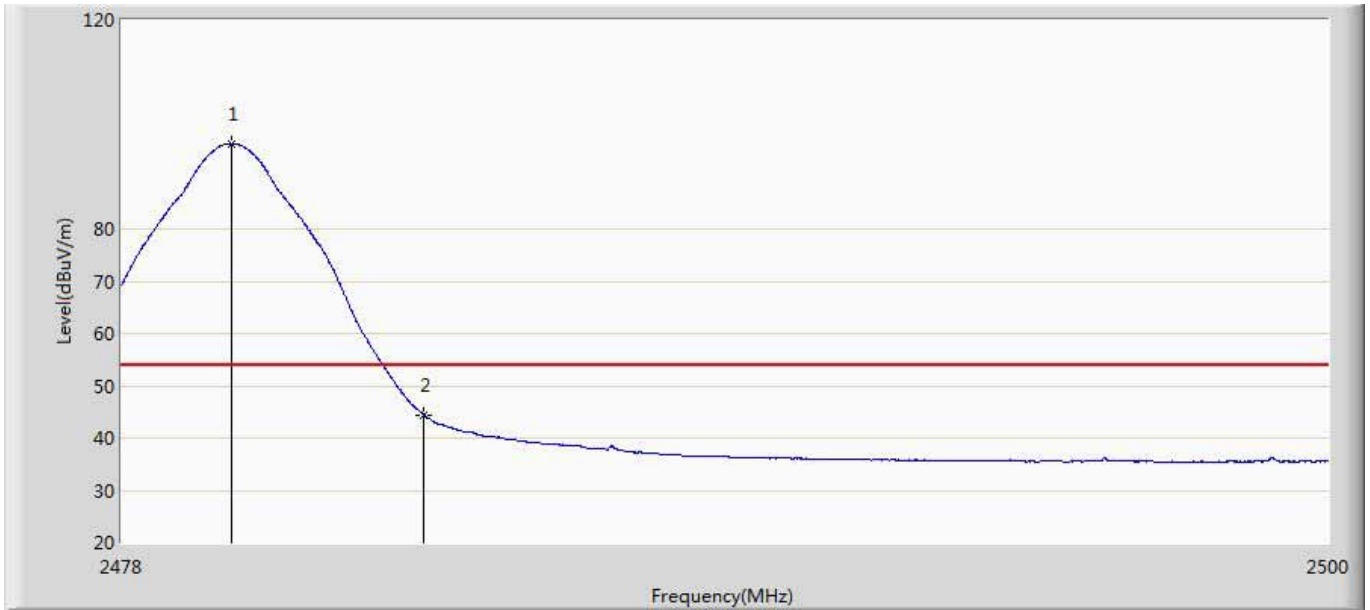

No	Mark	Frequency (MHz)	Measure Level (dBuV/m)	Reading Level (dBuV)	Over Limit (dB)	Limit (dBuV/m)	Factor (dB)	Type
1	*	2480.013	96.326	59.686	42.326	54.000	36.640	AV
2		2483.500	44.484	7.838	-9.516	54.000	36.646	AV

Engineer: Karl	
Site: AC5	Time: 2018/11/09 - 21:35
Limit: FCC_Part15.209_RE(3m)	Margin: 0
Probe: Horn_3117_00167055(1-18GHz)	Polarity: Vertical
EUT: LED lamp	Power: AC 120V/60Hz
Note: Mode 1:Transmit at 2480MHz by Zigbee	

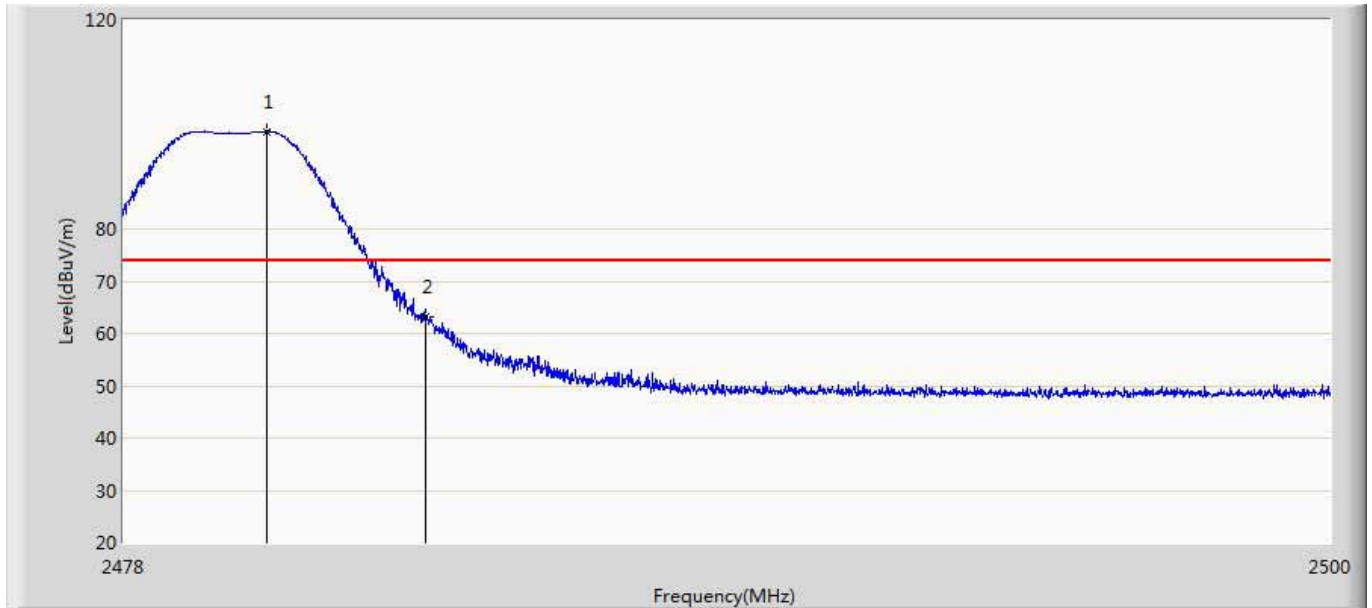

No	Mark	Frequency (MHz)	Measure Level (dBuV/m)	Reading Level (dBuV)	Over Limit (dB)	Limit (dBuV/m)	Factor (dB)	Type
1	*	2480.596	98.687	62.046	24.687	74.000	36.641	PK
2		2483.500	63.088	26.442	-10.912	74.000	36.646	PK

## 7. Occupied Bandwidth

### 7.1. Test Equipment

Occupied Bandwidth / TR-8					
Instrument	Manufacturer	Type No.	Serial No.	Cal. Date	Cal. Due Date
Spectrum Analyzer	Agilent	N9010A	MY48030494	2018.02.04	2019.02.03
EXA Spectrum Analyzer	Keysight	N9010A	MY55370495	2018.04.09	2019.04.08
MXA Signal Analyzer	Keysight	N9020A	MY56060147	2018.04.09	2019.04.08
Temperature/Humidity Meter	zhichen	ZC1-2	TR8-TH	2018.04.10	2019.04.09

Note: All equipment are calibrated with traceable calibrations. Each calibration is traceable to the national or international standards.

### 7.2. Test Setup

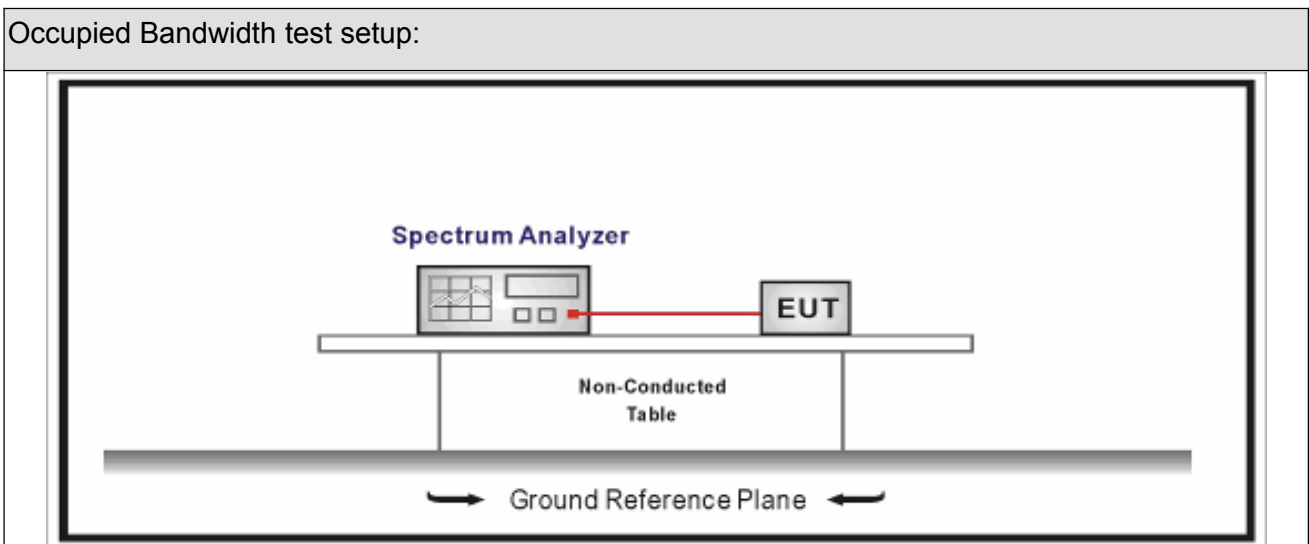

### 7.3. Limit



Occupied Bandwidth
Systems using digital modulation techniques operate in the 2400-2483.5 MHz. The minimum 6 dB bandwidth shall be at least 500 kHz

### 7.4. Test Procedure

Test Method			
	Reference Rule	Chapter	Description
<input checked="" type="checkbox"/>	ANSI C63.10	11.8	DTS bandwidth
	<input type="checkbox"/> ANSI C63.10	11.8.1	Option 1
	<input checked="" type="checkbox"/> ANSI C63.10	11.8.2	Option 2

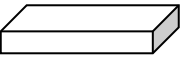
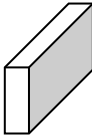
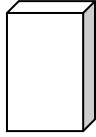
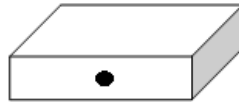

**7.5. EUT test definition**

Item	Occupied Bandwidth			
Device Category	<input type="checkbox"/>	Fixed point-to-point		
	<input type="checkbox"/>	Emit multiple directional beams, simultaneously or sequentially		
	<input checked="" type="checkbox"/>	Other cases		
Test mode	Mode 1			
Test method	<input type="checkbox"/>	Radiated		
		X Axis	Y Axis	Z Axis
				
		Worst Axis <input type="checkbox"/>	Worst Axis <input type="checkbox"/>	Worst Axis <input type="checkbox"/>
	<input checked="" type="checkbox"/>	Conducted		
	<input checked="" type="checkbox"/>	Chain 0		
				
	<input type="checkbox"/>	Chain 0	Chain 1	
				
	<input type="checkbox"/>	Chain 0	Chain 1	Chain 2
				

### 7.6. Test Result

Product Name	: LED lamp	Power	: AC 120V/60Hz
Test Mode	: Mode 1	Test Site	: TR-8
Test Date	: 2018.11.08	Test engineer	: Tommie

Mode	CH.	Test Freq. (MHz)	99% Occupied Bandwidth (kHz)	6dB Occupied Bandwidth (kHz)	Limit (kHz)	Result
1	11	2405	2240.8	1826	>500	Pass
1	20	2450	2223.3	1551	>500	Pass
1	26	2480	2310.6	1670	>500	Pass

Note : The worst case of Occupied Bandwidth as below:

#### Mode 1 CH26 (2480MHz)

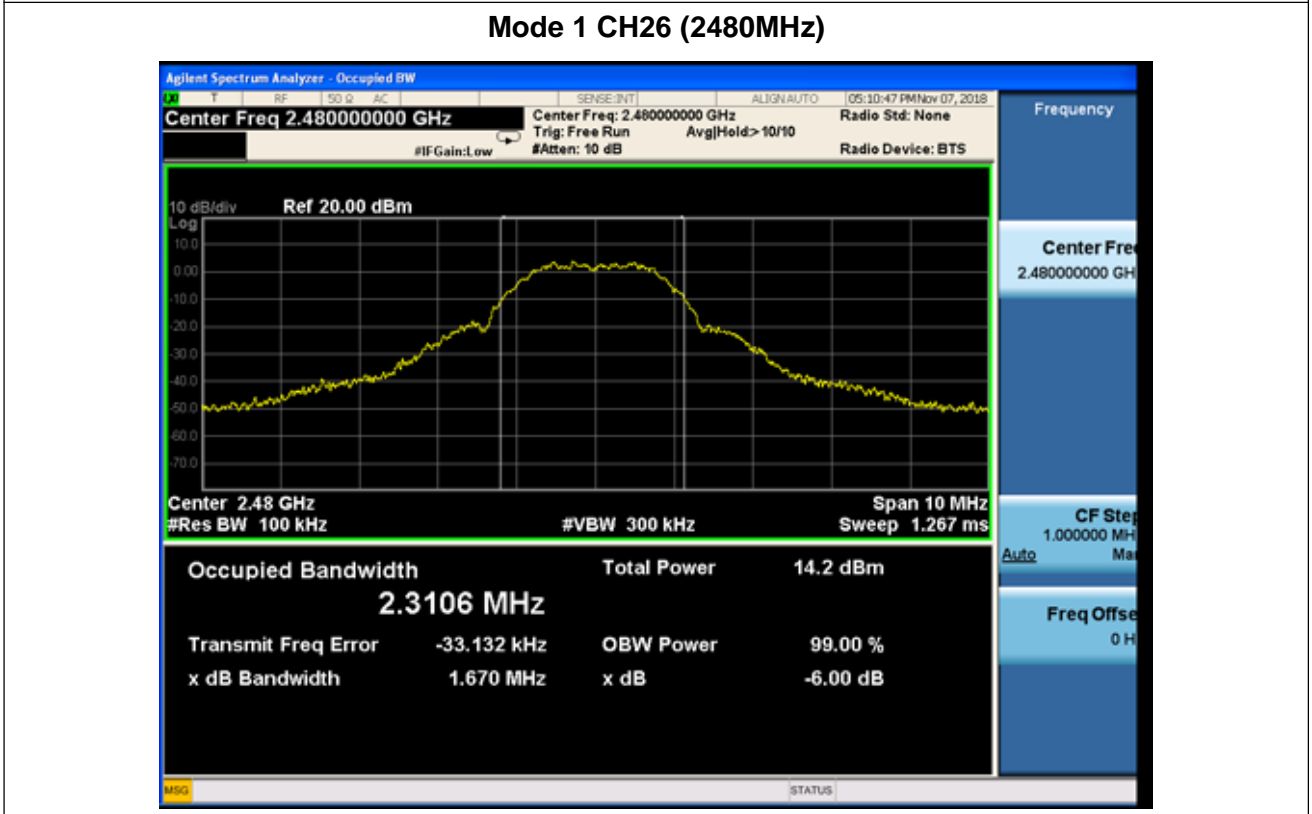

## 8. Fundamental emission output power

### 8.1. Test Equipment

Fundamental emission output power/ TR-8					
Instrument	Manufacturer	Type No.	Serial No.	Cal. Date	Cal. Due Date
Spectrum Analyzer	Agilent	E4446A	MY45300103	2018.01.04	2019.01.03
Spectrum Analyzer	Agilent	N9010A	MY48030494	2018.01.04	2019.01.03
Wideband Peak Power Meter	Anritsu	ML2495A	0905006	2018.10.14	2019.10.13
Power Sensor	Anritsu	MA2411B	0846014	2018.10.14	2019.10.13
Temperature/Humidity Meter	zhicheng	ZC1-2	TR8-TH	2018.04.10	2019.04.09

Note: All equipment are calibrated with traceable calibrations. Each calibration is traceable to the national or international standards.

### 8.2. Test Setup

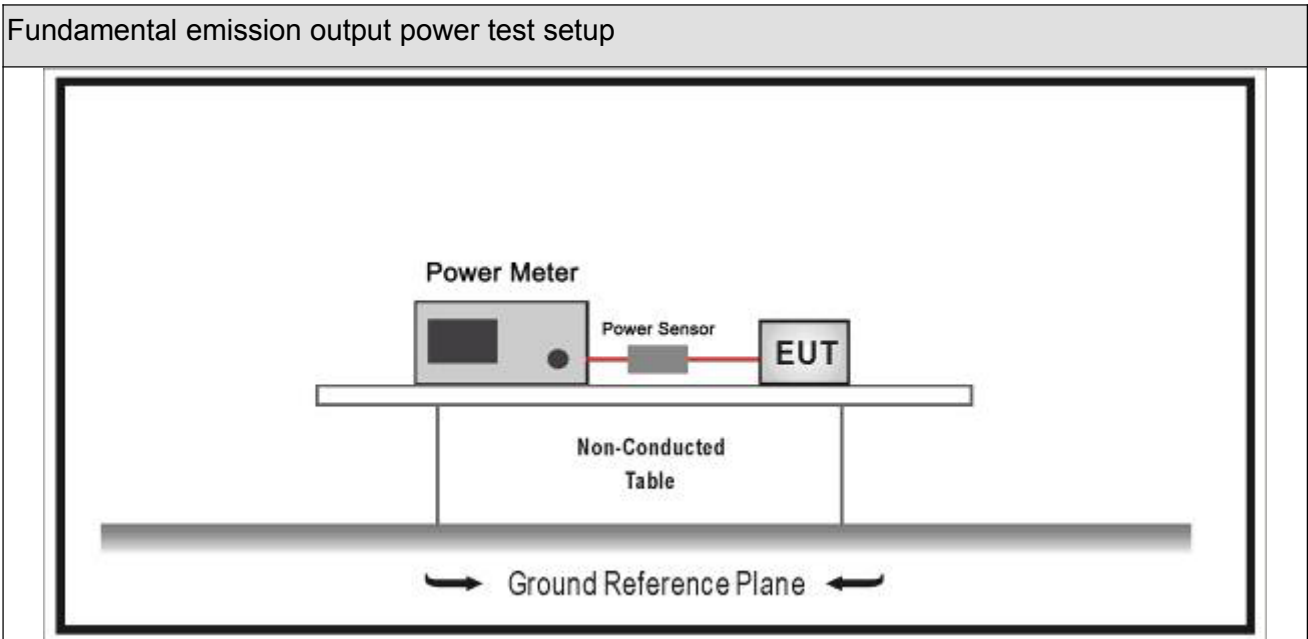





### 8.3. Limit

Fundamental emission output power Limit		
<input checked="" type="checkbox"/>	$G_{TX} < 6\text{dBi}$	$P_{out} \leq 30\text{dBm}$
<input type="checkbox"/>	$G_{TX} > 6\text{dBi}$	
<input type="checkbox"/>	Non-Fix point-point	$P_{out} \leq 30 - (G_{TX} - 6)$
<input type="checkbox"/>	Fix point-point	$P_{out} \leq 30 - [(G_{TX} - 6)]/3$
<input checked="" type="checkbox"/>	Point-to-multipoint	$P_{out} \leq 30 - (G_{TX} - 6)$
<input type="checkbox"/>	Overlap Beams	$P_{out} \leq 30 - [(G_{TX} - 6)]/3$
<input type="checkbox"/>	Aggregate power transmitted simultaneously on all beams	$P_{out} \leq 30 - [(G_{TX} - 6)]/3$
<input type="checkbox"/>	single directional beam	$P_{out} \leq 30 - [(G_{TX} - 6)]/3 + 8\text{dB}$
<p>Note 1 : <math>G_{TX}</math> directional gain of transmitting antennas.</p> <p>Note 2 : <math>P_{out}</math> is maximum peak conducted output power .</p>		

### 8.4. Test Procedure

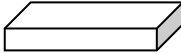
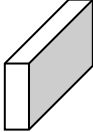
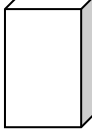
Fundamental emission output power Test Method					
	References Rule		Chapter	Description	
<input checked="" type="checkbox"/>	ANSI C63.10		11.9	Fundamental emission output power	
	<input checked="" type="checkbox"/>	ANSI C63.10		11.9.1	Maximum peak conducted output power
	<input type="checkbox"/>	ANSI C63.10	11.9.1.1	RBW ≥ DTS bandwidth	
	<input type="checkbox"/>	ANSI C63.10	11.9.1.2	Integrated band power method	
	<input checked="" type="checkbox"/>	ANSI C63.10	11.9.1.3	PKPM1 Peak power meter method	
	<input type="checkbox"/>	ANSI C63.10		11.9.2	Maximum conducted (average) output power
	<input type="checkbox"/>	ANSI C63.10		11.9.2.2	Measurement using a spectrum analyzer (SA)
	<input type="checkbox"/>	ANSI C63.10	11.9.2.2.2	Method AVGSA-1(Duty cycle 98%)	
	<input type="checkbox"/>	ANSI C63.10	11.9.2.2.3	Method AVGSA-1A(Duty cycle 98%)	
	<input type="checkbox"/>	ANSI C63.10	11.9.2.2.4	Method AVGSA-2(Duty cycle 98%)	
	<input type="checkbox"/>	ANSI C63.10	11.9.2.2.5	Method AVGSA-2A(Duty cycle 98%)	
	<input type="checkbox"/>	ANSI C63.10	11.9.2.2.4	Method AVGSA-3	
	<input type="checkbox"/>	ANSI C63.10	11.9.2.2.5	Method AVGSA-3A	
	<input type="checkbox"/>	ANSI C63.10		11.9.2.3	Measurement using a power meter (PM)
	<input type="checkbox"/>	ANSI C63.10	11.9.2.3.1	Method AVGPM	
<input type="checkbox"/>	ANSI C63.10	11.9.2.3.2	Method AVGPM-G		

**8.5. EUT test definition**

Item	Fundamental emission output power			
Device Category	<input type="checkbox"/>	Fixed point-to-point		
	<input type="checkbox"/>	Emit multiple directional beams, simultaneously or sequentially		
	<input checked="" type="checkbox"/>	Other cases		
Test mode	Mode 1			
Test method	<input type="checkbox"/>	Radiated		
		X Axis	Y Axis	Z Axis
				
		Worst Axis <input type="checkbox"/>	Worst Axis <input type="checkbox"/>	Worst Axis <input type="checkbox"/>
	<input checked="" type="checkbox"/>	Conducted		
	<input checked="" type="checkbox"/>	Chain 0		
				
	<input type="checkbox"/>	Chain 0	Chain 1	
				
	<input type="checkbox"/>	Chain 0	Chain 1	Chain 2
				

### 8.6. Test Result

Product Name	: LED lamp	Power	: AC 120V/60Hz
Test Mode	: Mode 1	Test Site	: TR-8
Test Date	: 2018.11.08	Test engineer	: Tommie

Mode	Channel	Test Frequency (MHz)	Measurement Power Output (dBm)	Limit (dBm)	Result
1	11	2405	10	30	Pass
1	20	2450	9.73	30	Pass
1	26	2480	9.41	30	Pass

## 9. Power Spectral Density

### 9.1. Test Equipment

Power Spectral Density / TR-8					
Instrument	Manufacturer	Type No.	Serial No.	Cal. Date	Cal. Due Date
Spectrum Analyzer	Agilent	N9010A	MY48030494	2018.02.04	2019.02.03
EXA Spectrum Analyzer	Keysight	N9010A	MY55370495	2018.04.09	2019.04.08
MXA Signal Analyzer	Keysight	N9020A	MY56060147	2018.04.09	2019.04.08
Temperature/Humidity Meter	zhichen	ZC1-2	TR8-TH	2018.04.10	2019.04.09

Note: All equipment are calibrated with traceable calibrations. Each calibration is traceable to the national or international standards.

### 9.2. Test Setup

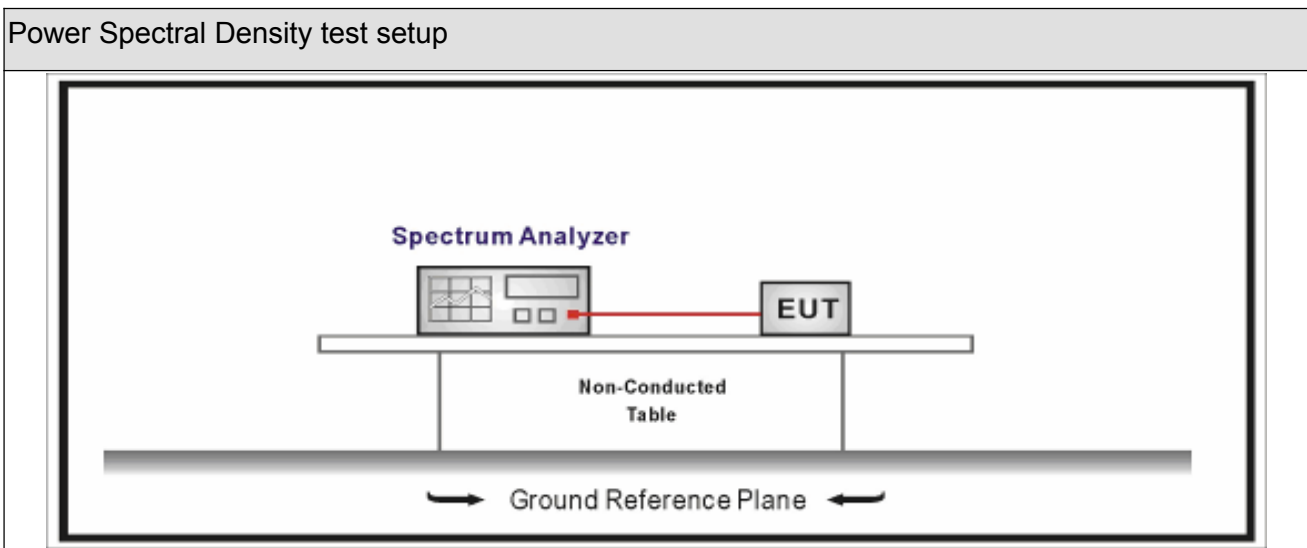

### 9.3. Limit

Power Spectral Density Limit
Power Spectral Density 8dBm/3kHz



### 9.4. Test Procedure

Power Spectral Density Test Method			
	References Rule	Chapter	Description
<input checked="" type="checkbox"/>	ANSI C63.10	11.10	Maximum power spectral density level in the fundamental emission
<input checked="" type="checkbox"/>	ANSI C63.10	11.10.2	Method PKPSD (peak PSD)
<input type="checkbox"/>	ANSI C63.10	11.10.3	Method AVGPSD-1(Duty cycle 98%)
<input type="checkbox"/>	ANSI C63.10	11.10.4	Method AVGPSD-1A(Duty cycle 98%)
<input type="checkbox"/>	ANSI C63.10	11.10.5	Method AVGPSD-2(Duty cycle < 98%)
<input type="checkbox"/>	ANSI C63.10	11.10.6	Method AVGPSD-2A(Duty cycle < 98%)
<input type="checkbox"/>	ANSI C63.10	11.10.7	Method AVGPSD-3
<input type="checkbox"/>	ANSI C63.10	11.10.8	Method AVGPSD-3A

**9.5. EUT test definition**

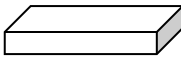
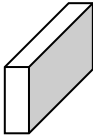
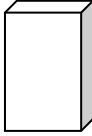
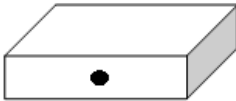
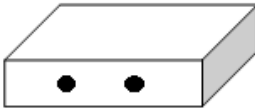
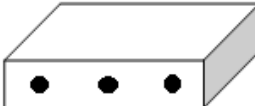
Item	Power Spectral Density Test Method			
Device Category	<input type="checkbox"/>	Fixed point-to-point		
	<input type="checkbox"/>	Emit multiple directional beams, simultaneously or sequentially		
	<input checked="" type="checkbox"/>	Other cases		
Test mode	Mode 1			
Test method	<input type="checkbox"/>	Radiated		
		X Axis	Y Axis	Z Axis
				
		Worst Axis <input type="checkbox"/>	Worst Axis <input type="checkbox"/>	Worst Axis <input type="checkbox"/>
	<input checked="" type="checkbox"/>	Conducted		
	<input checked="" type="checkbox"/>	Chain 0		
				
	<input type="checkbox"/>	Chain 0	Chain 1	
				
	<input type="checkbox"/>	Chain 0	Chain 1	Chain 2
				

### 9.6. Test Result

Product Name	: LED lamp	Power	: AC 120V/60Hz
Test Mode	: Mode 1	Test Site	: TR-8
Test Date	: 2018.11.08	Test engineer	: Tommie

Mode	Channel	Test Frequency (MHz)	Measurement PSD (dBm/3kHz)	Total PSD (dBm/3kHz)	Limit (dBm/3kHz)	Result
1	11	2405	-6.379	-6.379	8	Pass
1	15	2425	-6.667	-6.667	8	Pass
1	20	2450	-8.308	-8.308	8	Pass
1	25	2475	-8.516	-8.516	8	Pass
1	26	2480	-7.768	-7.768	8	Pass

Note : The worst case of Power Spectral Density as below:

**Mode 1 CH11(2405MHz)**

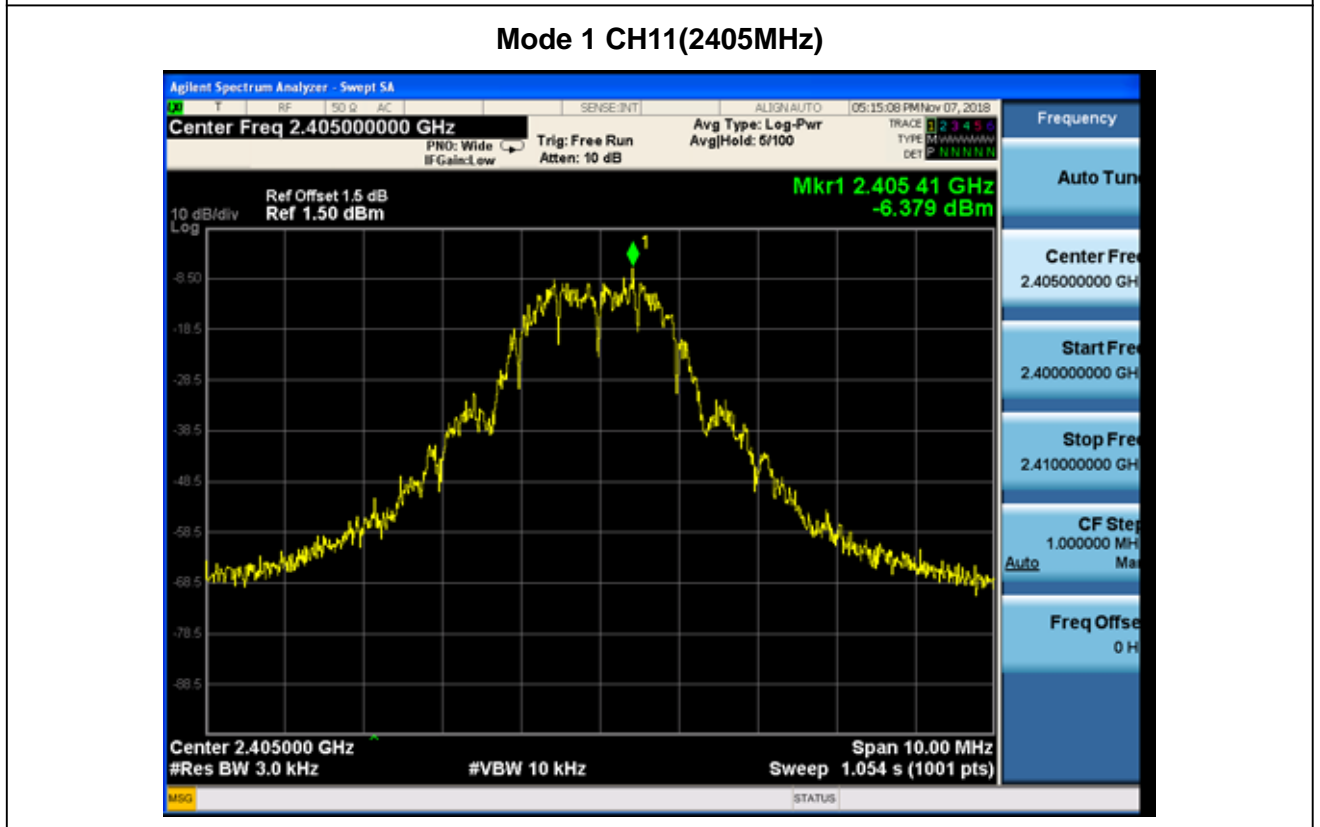

## 10. Antenna Requirement

### 10.1. Limit

Antenna Requirement Limit
<p>An intentional radiator shall be designed to ensure that no antenna other than that furnished by the responsible party shall be used with the device. The use of a permanently attached antenna or of an antenna that uses a unique coupling to the intentional radiator shall be considered sufficient to comply with the provisions of this section. The manufacturer may design the unit so that a broken antenna can be replaced by the user, but the use of a standard antenna jack or electrical connector is prohibited. This requirement does not apply to carrier current devices or to devices operated under the provisions of §15.211, §15.213, §15.217, §15.219, or §15.221. Further, this requirement does not apply to intentional radiators that must be professionally installed, such as perimeter protection systems and some field disturbance sensors, or to other intentional radiators which, in accordance with §15.31(d), must be measured at the installation site. However, the installer shall be responsible for ensuring that the proper antenna is employed so that the limits in this part are not exceeded.</p>

### 10.2. Antenna Connector Construction

Antenna Connector Construction	
<input checked="" type="checkbox"/>	The use of a permanently attached antenna
<input type="checkbox"/>	The antenna use of a unique coupling to the intentional radiator
<input type="checkbox"/>	The use of a nonstandard antenna jack or electrical connector
Please refer to the attached document "Internal Photograph" to show the antenna connector.	

\_\_\_\_\_ The End \_\_\_\_\_