



Test Report

FCC Part15 Subpart C & RSS-247 Issue 2

Product Name : LED lamp
Model No. : 9290022175
FCC ID : 2AGBW9290022175X
IC : 20812-2175X

Applicant : Signify (China) Investment Co., Ltd
Address : Building no.9, Lane 888, Tianlin Road, Minhang
District, Shanghai 200233, China

Date of Receipt : Mar. 07, 2019
Issued Date : Mar. 08, 2019
Report No. : 1932077R-RF-US-P06V02
Report Version : V1.0

Note: This report was based on DEKRA Report No. 18B2025R-RF-US-P06V02, only updated Product Name, Model No., and Address.

The test results relate only to the samples tested.

The test results shown in the test report are traceable to the national/international standard through the calibration of the equipment and evaluated measurement uncertainty herein.

This report must not be used to claim product endorsement by TAF, A2LA or any agency of the government.

The test report shall not be reproduced without the written approval of DEKRA Testing & Certification (Suzhou) Co., Ltd.

Test Report Certification

Issued Date : Mar. 08, 2019
Report No. : 1932077R-RF-US-P06V02



Product Name : LED lamp
 Applicant : Signify (China) Investment Co., Ltd
 Address : Building no.9, Lane 888, Tianlin Road, Minhang District, Shanghai 200233, China
 Manufacturer : Signify (China) Investment Co., Ltd
 Address : Building no.9, Lane 888, Tianlin Road, Minhang District, Shanghai 200233, China
 Model No. : 9290022175
 FCC ID : 2AGBW9290022175X
 IC : 20812-2175X
 Brand Name : Philips
 EUT Voltage : 110 – 130 Vac, 50-60 Hz, 8.5W
 Test Voltage : AC 120V/60Hz
 Applicable Standard : FCC CFR Title 47 Part 15 Subpart C
 ANSI C63.10:2013
 KDB 558074 D01v05
 RSS-Gen Issue 5 / RSS-247 Issue 2
 Test Result : Complied
 Performed Location : DEKRA Testing & Certification (Suzhou) Co., Ltd.
 No.99 Hongye Rd., Suzhou Industrial Park, Suzhou, 215006, Jiangsu, China
 TEL: +86-512-6251-5088 / FAX: +86-512-6251-5098
 FCC Designation Number: CN1199; ISED Lab Code: 4075B

Documented By : Kitty Li
 (Adm. Specialist: Kitty Li)

Reviewed By : Frank He
 (Senior Project Manager: Frank He)

Approved By : Jack Zhang
 (Engineering Supervisor: Jack Zhang)

TABLE OF CONTENTS

Description	Page
1. General Information	6
1.1. EUT Description	6
1.2. Working Frequency of Each Channel:	7
1.3. Antenna information	7
1.4. Mode of Operation.....	8
1.5. Tested System Details	8
1.6. Configuration of Tested System.....	9
1.7. EUT Exercise Software.....	10
2. Technical Test	11
2.1. Summary of Test Result.....	11
2.2. Test Environment.....	13
2.3. Measurement Uncertainty.....	13
3. AC Power Line Conducted Emission	14
3.1. Test Equipment.....	14
3.2. Test Setup.....	14
3.3. Limit.....	15
3.4. Test Procedure	15
3.5. Test Result.....	16
4. Emissions in restricted frequency bands	22
4.1. Test Equipment.....	22
4.2. Test Setup.....	23
4.3. Limit.....	24
4.4. Test Procedure	27
4.5. EUT test Axis definition.....	28
4.6. Test Result.....	29
5. Emissions in non-restricted frequency bands	57
5.1. Test Equipment.....	57
5.2. Test Setup.....	57
5.3. Limit.....	58
5.4. Test Procedure	59
5.5. EUT test Axis definition.....	60
5.6. Test Result.....	61
6. Radiated Emission Band Edge	62
6.1. Test Equipment.....	62
6.2. Test Setup.....	63
6.3. Limit.....	63
6.4. Test Procedure	64

- 6.5. EUT test definition 65
- 6.6. Duty Cycle 66
- 6.7. Test Result 67
- 7. Occupied Bandwidth 67
 - 7.1. Test Equipment..... 91
 - 7.2. Test Setup..... 91
 - 7.3. Limit..... 92
 - 7.4. Test Procedure 92
 - 7.5. EUT test definition 93
 - 7.6. Test Result..... 94
- 8. Fundamental emission output power 95
 - 8.1. Test Equipment..... 95
 - 8.2. Test Setup..... 95
 - 8.3. Limit..... 96
 - 8.4. Test Procedure 97
 - 8.5. EUT test definition 98
 - 8.6. Test Result..... 99
- 9. Power Spectral Density 100
 - 9.1. Test Equipment..... 100
 - 9.2. Test Setup..... 100
 - 9.3. Limit..... 100
 - 9.4. Test Procedure 101
 - 9.5. EUT test definition 102
 - 9.6. Test Result..... 103
- 10. Antenna Requirement..... 104
 - 10.1. Limit..... 104
 - 10.2. Antenna Connector Construction..... 104

History of This Test Report

REPORT NO.	VERSION	DESCRIPTION	ISSUED DATE
1932077R-RF-US-P06V02	V1.0	Initial Issued Report	Mar. 08, 2019

1. General Information

1.1. EUT Description

Product Name	LED lamp
Brand Name	Philips
Model No.	9290022175
EUT Voltage	110 – 130 Vac, 50-60 Hz, 8.5W
Frequency Range	2405 ~ 2480MHz
Channel Number	16
Type of Modulation	O-QPSK
Data Rate	250kbps
Antenna Type	Reference to Antenna List
Peak Antenna Gain	Reference to Antenna List

Note: LED lamp supports two kinds of lighting source (APT/LTN), and two kinds of Crystal oscillator (Diode (FL3840023)_2017/ Murata(XRCGB38M400FXH17R0)), there is not any change in RF design, circuitry or construction for this device, including RF parameters (antenna, software, firmware and hardware versions, power, frequency ranges, etc.), so only spurious emission and bandedge were tested for additional light source and crystal oscillator combinations, and we use the worst combination for all other test items of RF compliance.

1.2. Working Frequency of Each Channel:

Zigbee Working Frequency of Each Channel:							
Channel	Frequency	Channel	Frequency	Channel	Frequency	Channel	Frequency
11	2405 MHz	12	2410 MHz	13	2415 MHz	14	2420 MHz
15	2425 MHz	16	2430 MHz	17	2435 MHz	18	2440 MHz
19	2445 MHz	20	2450 MHz	21	2455 MHz	22	2460 MHz
23	2465 MHz	24	2470 MHz	25	2475 MHz	26	2480 MHz

1.3. Antenna information

Antenna manufacturer	N/A		
Antenna Delivery	<input checked="" type="checkbox"/> 1*TX+1*RX	<input type="checkbox"/> 2*TX+2*RX	<input type="checkbox"/> 3*TX+3*RX
Antenna technology	<input checked="" type="checkbox"/> SISO		
	<input type="checkbox"/> MIMO	<input type="checkbox"/> Basic	
		<input type="checkbox"/> CDD	
		<input type="checkbox"/> Beam-forming	
Antenna Type	<input type="checkbox"/> External	<input type="checkbox"/> Dipole	
	<input checked="" type="checkbox"/> Internal	<input type="checkbox"/> PIFA	
		<input checked="" type="checkbox"/> PCB	
		<input type="checkbox"/> Ceramic Chip Antenna	
		<input type="checkbox"/> Metal plate type F antenna	
Antenna Gain	3.4dBi		

1.4. Mode of Operation

DEKRA has verified the construction and function in typical operation. See the different modes shown in this test report and defined as:

Test Modes List
Mode 1: Transmit by Zigbee

1.5. Tested System Details

The types for all equipment, plus descriptions of all cables used in the tested system (including inserted cards) are:

No.	Product	Manufacturer	Model No.	Serial No.	Power Cord
1	Notebook	Think Pad	2526	LV-A3285	Power by adapter
A	USB Control Cable	N/A	N/A	N/A	Shield, 1m
B	USB Control Cable	N/A	N/A	N/A	Shield, 10m

1.6. Configuration of Tested System

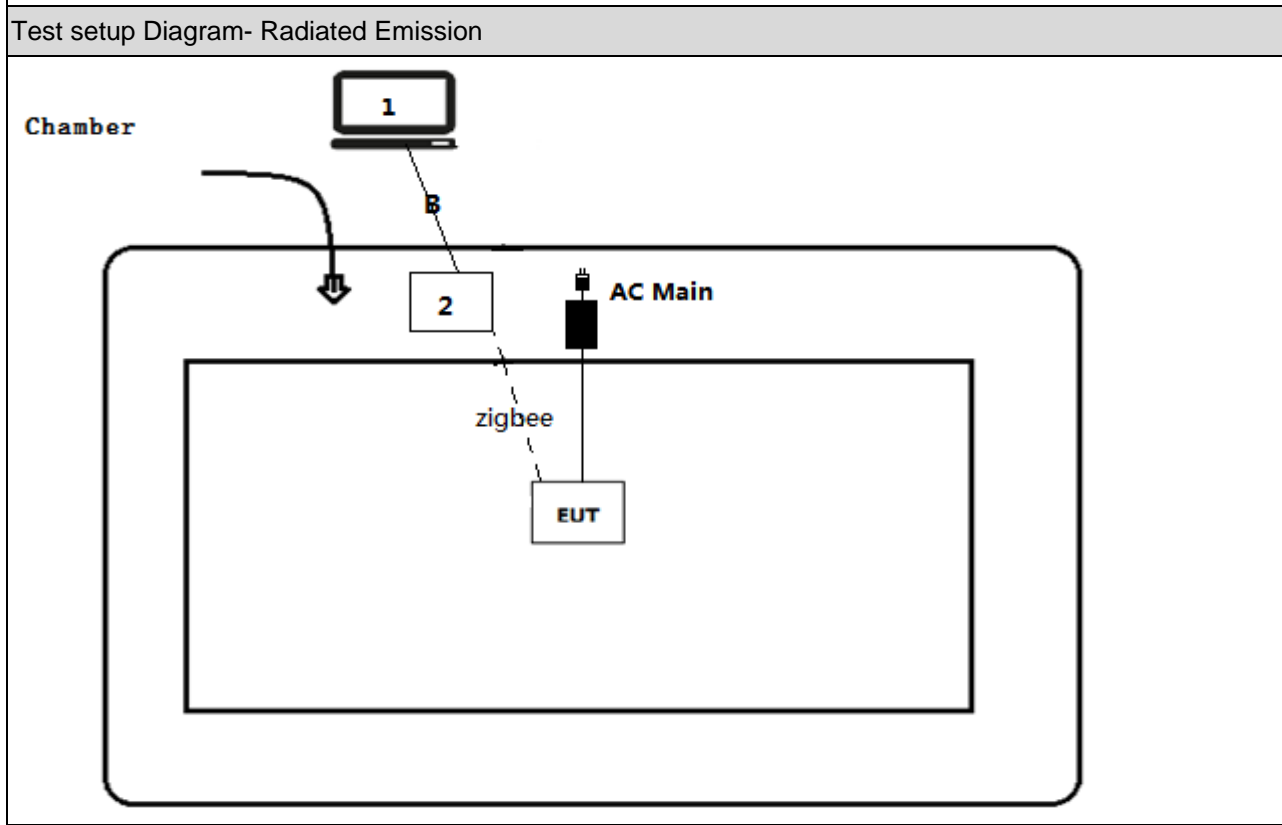
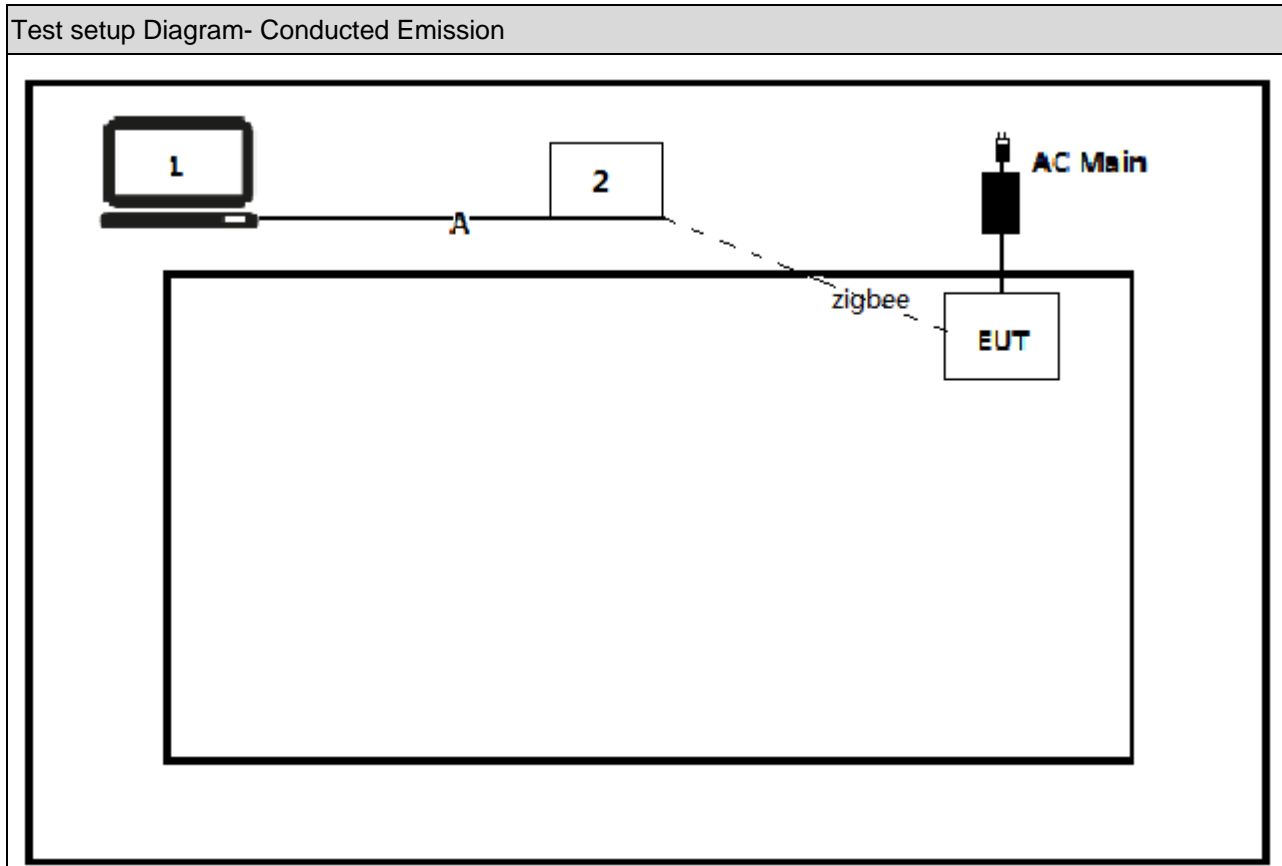

1.7. EUT Exercise Software

1	Setup the EUT and simulators as shown on above.
2	Turn on the power of equipment.
3	Run the test software [FCC Assist V2.4].
4	Select the transmission mode and test channel, then start test.

2. Technical Test

2.1. Summary of Test Result

FCC:

Performed Test Item	Normative References	Limit	Result
AC Power Line Conducted Emission	FCC CFR Title 47 Part 15 Subpart C Section 15.207	FCC 15.207	PASS
Emissions in restricted frequency bands	FCC CFR Title 47 Part 15 Subpart C Section 15.209	FCC 15.209	PASS
Emissions in non-restricted frequency bands	FCC CFR Title 47 Part 15 Subpart C Section 15.247(d)	20dBc	PASS
Radiated Emission Band Edge	FCC CFR Title 47 Part 15 Subpart C 15.247(d)	FCC 15.209	PASS
Occupied Bandwidth	FCC CFR Title 47 Part 15 Subpart C Section 15.247(a)(2)	500kHz	PASS
Fundamental emission output power	FCC CFR Title 47 Part 15 Subpart C Section 15.247(b)(3)	30dBm	PASS
Power Spectral Density	FCC CFR Title 47 Part 15 Subpart C Section 15.247(e)	8dBm/3kHz	PASS
Antenna Requirement	FCC CFR Title 47 Part 15 Subpart C Section 15.203	FCC 15.203	PASS

ISED:

Performed Test Item	Normative References	Limit	Result
AC Power Line Conducted Emission	RSS-Gen Issue 4 Section 8.8	RSS-Gen	PASS
Emissions in restricted frequency bands	RSS-Gen Issue 4 Section 8.9	RSS-Gen	PASS
Emissions in non-restricted frequency bands	RSS-247 Issue 2 Section A5.5	20dBc	PASS
Radiated Emission Band Edge	RSS-247 Issue 2 Section A5.5	RSS-247	PASS
Occupied Bandwidth	RSS-Gen Issue 4 Section 6.6 RSS-247 Issue 2 Section A5.2(1)	500kHz	PASS
Fundamental emission output power	RSS-247 Issue 2 Section A5.4(4)	30dBm	PASS
Power Spectral Density	RSS-247 Issue 2 Section A5.2(2)	8dBm/3kHz	PASS
Antenna Requirement	RSS-Gen Issue 4 Section 8.3	RSS-Gen Issue 4	PASS

2.2. Test Environment

Items	Required (IEC 68-1)	Actual
Temperature (°C)	15-35	21
Humidity (%RH)	25-75	50
Barometric pressure (mbar)	860-1060	950-1000

2.3. Measurement Uncertainty

Test Items	Uncertainty
AC Power Line Conducted Emission	$\pm 2.02\text{dB}$
Radiated Emission	Below 1GHz $\pm 3.8\text{ dB}$
	Above 1GHz $\pm 3.9\text{ dB}$
RF Antenna Port Conducted Emission	$\pm 1.27\text{dB}$
Radiated Emission Band Edge	$\pm 3.9\text{dB}$
Occupied Bandwidth	$\pm 1\text{kHz}$
Power Spectral Density	$\pm 1.27\text{dB}$

3. AC Power Line Conducted Emission

3.1. Test Equipment

AC Power Line Conducted Emission / TR-1				
Instrument	Manufacturer	Type No.	Serial No.	Cal. Due Date
EMI Test Receiver	R&S	ESCI	100906	2019.03.04
Two-Line V-Network	R&S	ENV 216	101189	2019.07.15
Two-Line V-Network	R&S	ENV 216	101044	2019.09.15
50ohm Coaxial Switch	Anritsu	MP59B	6200464462	N/A
50ohm Termination	SHX	TF2	07081402	2019.09.15
Temperature/Humidity Meter	Zhichen	ZC1-2	TR1-TH	2019.01.03

Note: All equipment are calibrated with traceable calibrations. Each calibration is traceable to the national or international standards.

3.2. Test Setup

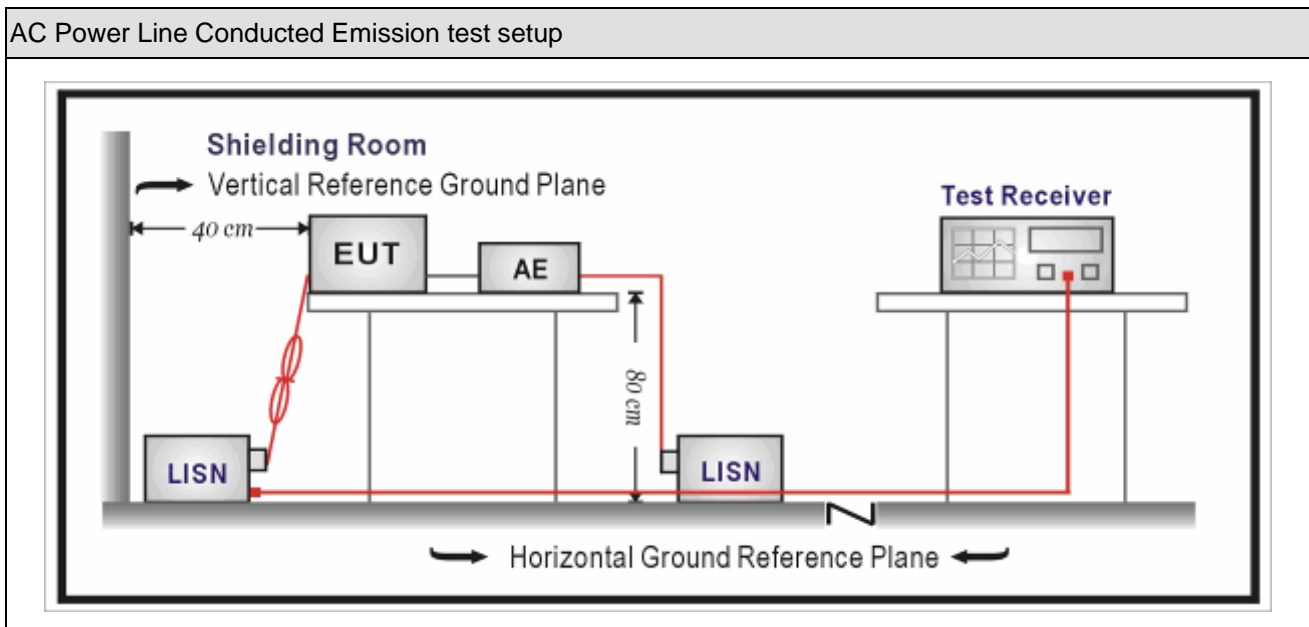

3.3. Limit

Frequency of Emission (MHz)	Conducted Limit	
	Quasi-peak (dB μ V)	Average (dB μ V)
0.15-0.5	66 to 56	56 to 46
0.5-5	56	46
5-30	60	50

Note 1: The lower limit shall apply at the transition frequencies.
 Note 2: The limit decreases linearly with the logarithm of the frequency in the range 0.15 MHz to 0.5 MHz.

3.4. Test Procedure

Test Method			
	References Rule	Chapter	Item
<input checked="" type="checkbox"/>	ANSI C63.10-2013	6.2	Standard test method for ac power-line conducted emissions from unlicensed wireless devices
<input checked="" type="checkbox"/>	ANSI C63.4-2014	7	AC power-line conducted emission measurements

3.5. Test Result

Engineer: LEon	
Site: TR1	Time: 2018/11/16
Limit: FCC_Part15.207_CE_AC Power	Margin: 0
Probe: ENV216_101190(0.009-30MHz)	Polarity: Line
EUT: LED lamp (Crystal oscillator: Diode (FL3840023)_2017; Lighting source: APT)	Power: AC 120V/60Hz
Note: Mode1: Transmit at 2405MHz by Zigbee	

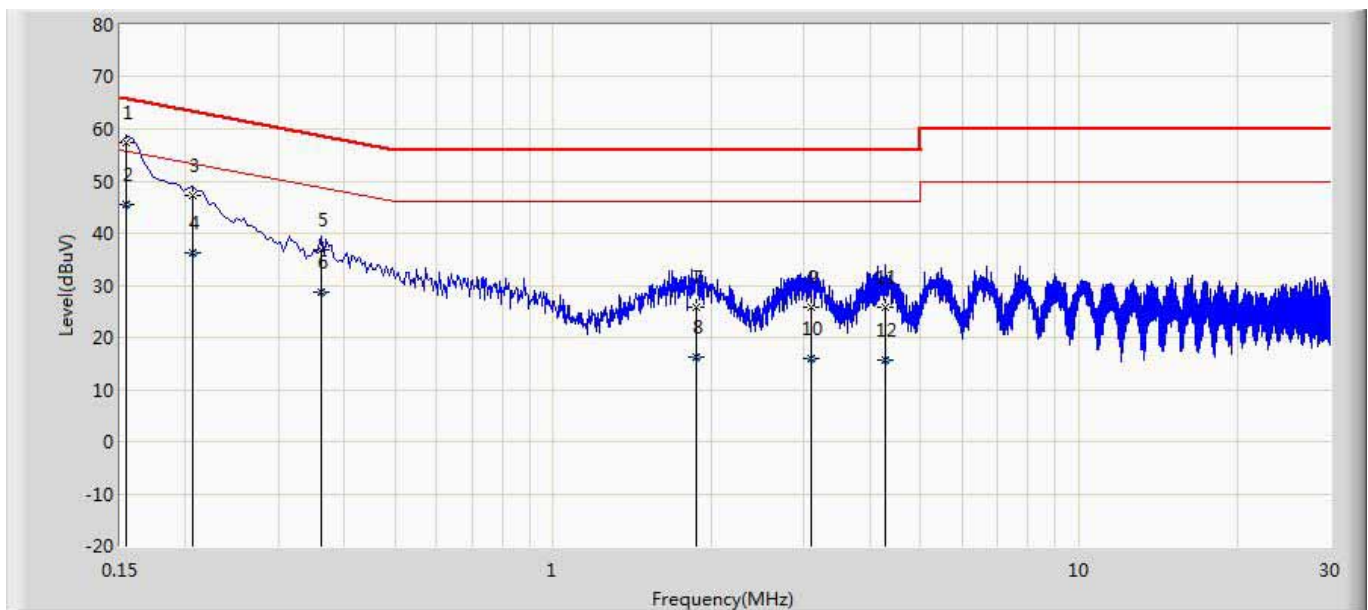

No	Mark	Frequency (MHz)	Measure Level (dBuV)	Reading Level (dBuV)	Over Limit (dB)	Limit (dBuV)	Probe (dB)	Cable (dB)	Amp (dB)	Type
1	*	0.154	57.305	47.674	-8.581	65.886	9.609	0.021	0.000	QP
2		0.154	45.461	35.830	-10.425	55.886	9.609	0.021	0.000	AV
3		0.206	47.164	37.532	-17.236	64.400	9.601	0.031	0.000	QP
4		0.206	36.323	26.691	-18.077	54.400	9.601	0.031	0.000	AV
5		0.362	36.702	27.067	-23.241	59.943	9.600	0.035	0.000	QP
6		0.362	28.582	18.947	-21.361	49.943	9.600	0.035	0.000	AV
7		1.870	25.924	16.238	-30.076	56.000	9.610	0.076	0.000	QP
8		1.870	16.131	6.445	-29.869	46.000	9.610	0.076	0.000	AV
9		3.090	25.888	16.160	-30.112	56.000	9.628	0.100	0.000	QP
10		3.090	15.991	6.263	-30.009	46.000	9.628	0.100	0.000	AV
11		4.270	25.876	16.102	-30.124	56.000	9.648	0.126	0.000	QP
12		4.270	15.684	5.910	-30.316	46.000	9.648	0.126	0.000	AV

Note:

1. " * ", means this data is the worst emission level.
2. Measurement Level = Reading Level + Factor(Probe+Cable-Amp).

Engineer: LEon	
Site: TR1	Time: 2018/11/16
Limit: FCC_Part15.207_CE_AC Power	Margin: 0
Probe: ENV216_101190(0.009-30MHz)	Polarity: Neutral
EUT: LED lamp (Crystal oscillator: Diode (FL3840023)_2017; Lighting source: APT)	Power: AC 120V/60Hz
Note: Mode1: Transmit at 2405MHz by Zigbee	

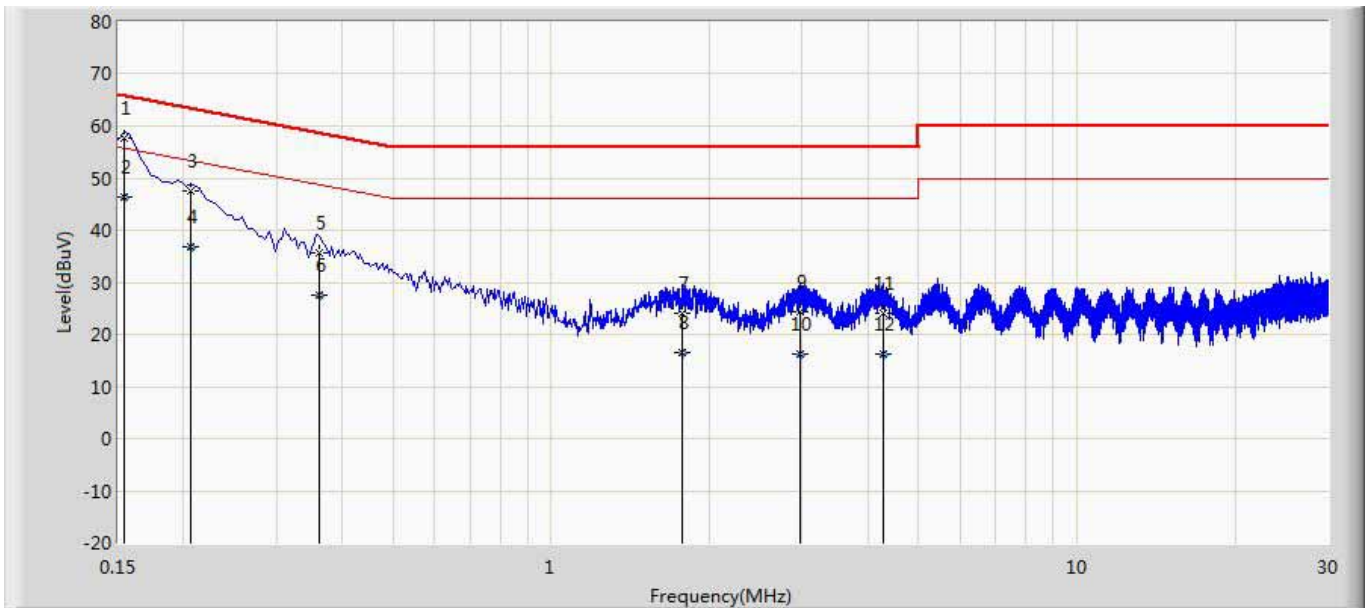

No	Mark	Frequency (MHz)	Measure Level (dBuV)	Reading Level (dBuV)	Over Limit (dB)	Limit (dBuV)	Probe (dB)	Cable (dB)	Amp (dB)	Type
1	*	0.154	57.731	48.116	-8.155	65.886	9.593	0.021	0.000	QP
2		0.154	46.308	36.694	-9.578	55.886	9.593	0.021	0.000	AV
3		0.206	47.470	37.841	-16.930	64.400	9.599	0.031	0.000	QP
4		0.206	36.954	27.324	-17.446	54.400	9.599	0.031	0.000	AV
5		0.362	35.652	26.023	-24.290	59.943	9.594	0.035	0.000	QP
6		0.362	27.576	17.947	-22.366	49.943	9.594	0.035	0.000	AV
7		1.774	24.132	14.451	-31.868	56.000	9.606	0.076	0.000	QP
8		1.774	16.401	6.719	-29.599	46.000	9.606	0.076	0.000	AV
9		2.966	24.242	14.518	-31.758	56.000	9.623	0.101	0.000	QP
10		2.966	16.102	6.378	-29.898	46.000	9.623	0.101	0.000	AV
11		4.290	24.149	14.381	-31.851	56.000	9.641	0.128	0.000	QP
12		4.290	16.121	6.353	-29.879	46.000	9.641	0.128	0.000	AV

Note:

1. " * ", means this data is the worst emission level.
2. Measurement Level = Reading Level + Factor(Probe+Cable-Amp).

Engineer: LEon	
Site: TR1	Time: 2018/11/16
Limit: FCC_Part15.207_CE_AC Power	Margin: 0
Probe: ENV216_101190(0.009-30MHz)	Polarity: Line
EUT: LED lamp (Crystal oscillator: Diode (FL3840023)_2017; Lighting source: LTN)	Power: AC 120V/60Hz
Note: Mode1: Transmit at 2405MHz by Zigbee	

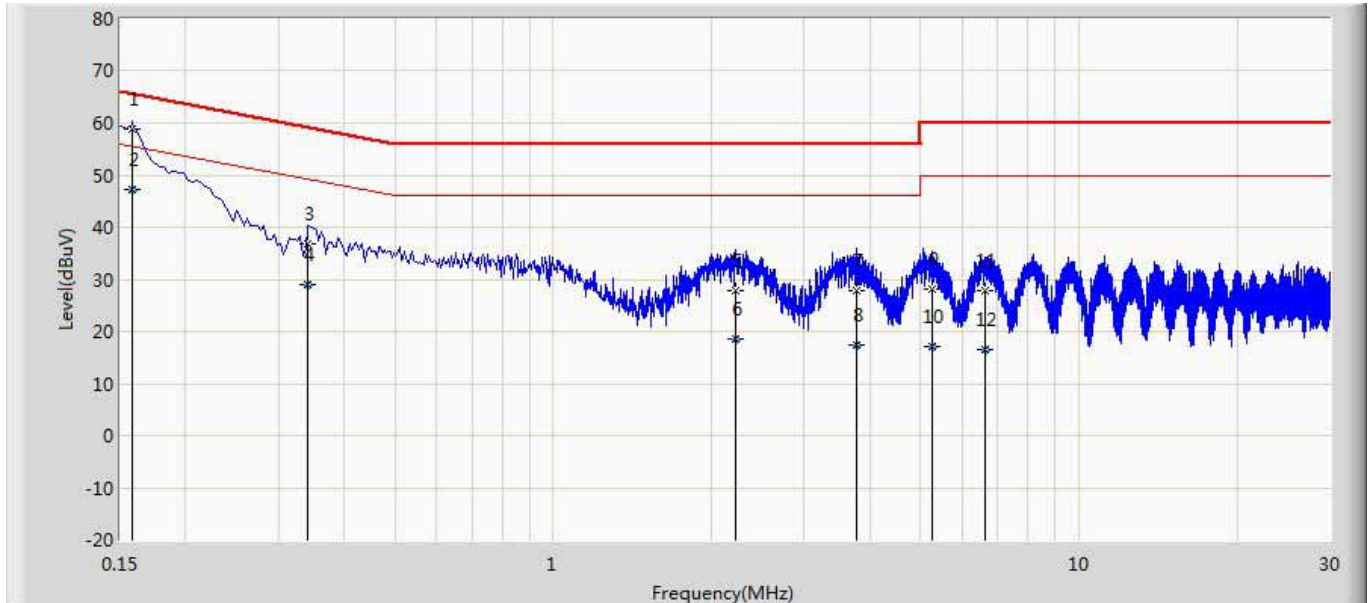

No	Mark	Frequency (MHz)	Measure Level (dBuV)	Reading Level (dBuV)	Over Limit (dB)	Limit (dBuV)	Probe (dB)	Cable (dB)	Amp (dB)	Type
1	*	0.158	58.952	49.321	-6.820	65.771	9.608	0.022	0.000	QP
2		0.158	47.379	37.749	-8.392	55.771	9.608	0.022	0.000	AV
3		0.342	36.698	27.059	-23.816	60.514	9.600	0.040	0.000	QP
4		0.342	28.923	19.284	-21.591	50.514	9.600	0.040	0.000	AV
5		2.218	27.967	18.261	-28.033	56.000	9.614	0.092	0.000	QP
6		2.218	18.433	8.727	-27.567	46.000	9.614	0.092	0.000	AV
7		3.766	27.762	18.004	-28.238	56.000	9.639	0.119	0.000	QP
8		3.766	17.386	7.628	-28.614	46.000	9.639	0.119	0.000	AV
9		5.266	28.108	18.303	-31.892	60.000	9.665	0.139	0.000	QP
10		5.266	17.008	7.203	-32.992	50.000	9.665	0.139	0.000	AV
11		6.634	27.788	17.934	-32.212	60.000	9.693	0.161	0.000	QP
12		6.634	16.644	6.789	-33.356	50.000	9.693	0.161	0.000	AV

Note:

1. " * ", means this data is the worst emission level.
2. Measurement Level = Reading Level + Factor(Probe+Cable+Amp).

Engineer: LEon	
Site: TR1	Time: 2018/11/16
Limit: FCC_Part15.207_CE_AC Power	Margin: 0
Probe: ENV216_101190(0.009-30MHz)	Polarity: Neutral
EUT: LED lamp (Crystal oscillator: Diode (FL3840023)_2017; Lighting source: LTN)	Power: AC 120V/60Hz
Note: Mode1: Transmit at 2405MHz by Zigbee	

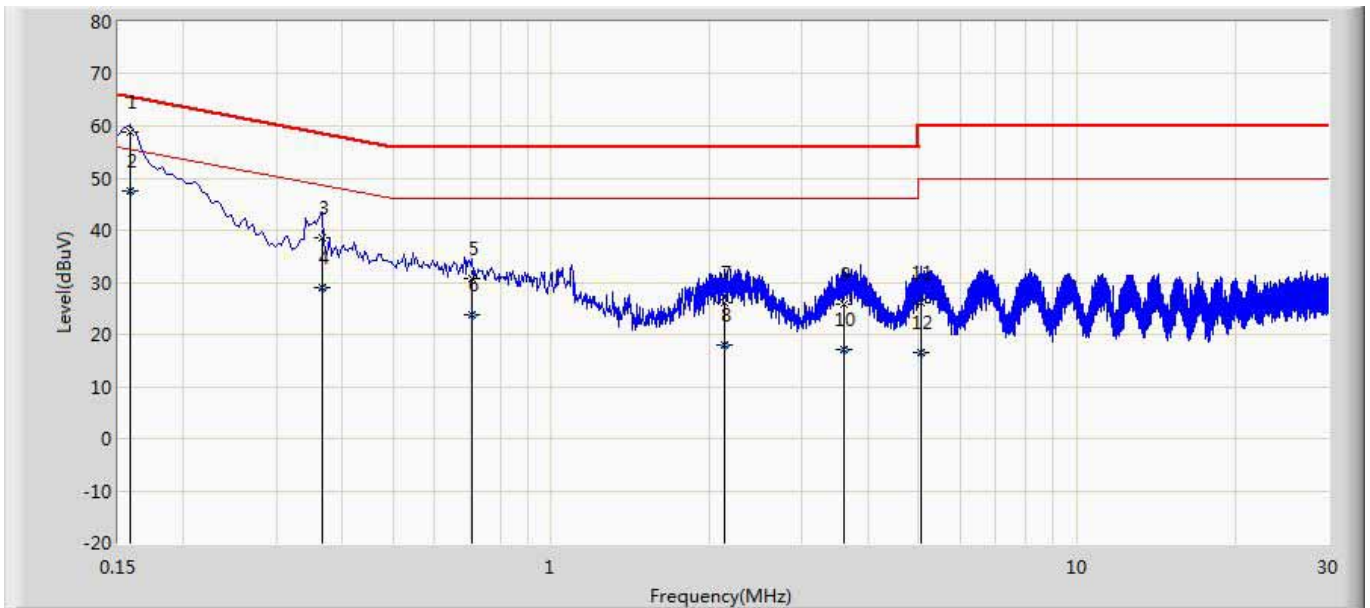

No	Mark	Frequency (MHz)	Measure Level (dBuV)	Reading Level (dBuV)	Over Limit (dB)	Limit (dBuV)	Probe (dB)	Cable (dB)	Amp (dB)	Type
1	*	0.158	58.979	49.364	-6.793	65.771	9.592	0.022	0.000	QP
2		0.158	47.604	37.989	-8.168	55.771	9.592	0.022	0.000	AV
3		0.366	38.515	28.887	-21.313	59.829	9.594	0.034	0.000	QP
4		0.366	29.113	19.485	-20.715	49.829	9.594	0.034	0.000	AV
5		0.706	30.728	21.092	-25.272	56.000	9.590	0.046	0.000	QP
6		0.706	23.748	14.113	-22.252	46.000	9.590	0.046	0.000	AV
7		2.130	26.005	16.302	-29.995	56.000	9.612	0.091	0.000	QP
8		2.130	18.037	8.335	-27.963	46.000	9.612	0.091	0.000	AV
9		3.606	25.939	16.192	-30.061	56.000	9.631	0.116	0.000	QP
10		3.606	17.060	7.313	-28.940	46.000	9.631	0.116	0.000	AV
11		5.058	25.959	16.171	-34.041	60.000	9.651	0.137	0.000	QP
12		5.058	16.550	6.762	-33.450	50.000	9.651	0.137	0.000	AV

Note:

1. " * ", means this data is the worst emission level.
2. Measurement Level = Reading Level + Factor(Probe+Cable-Amp).

Engineer: LEon	
Site: TR1	Time: 2018/11/15
Limit: FCC_Part15.207_CE_AC Power	Margin: 0
Probe: ENV216_101190(0.009-30MHz)	Polarity: Line
EUT: LED lamp (Crystal oscillator: Murata(XRCGB38M400FXH17R0))	Power: AC 120V/60Hz
Note: Mode1: Transmit at 2405MHz by Zigbee	

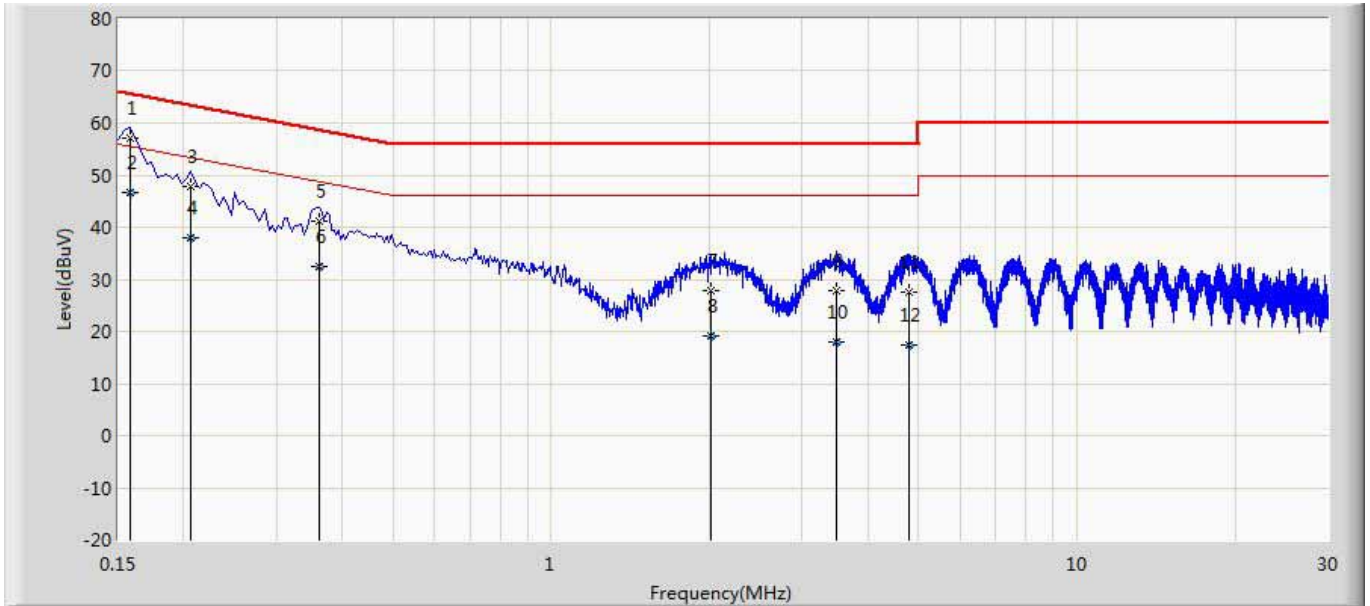

No	Mark	Frequency (MHz)	Measure Level (dBuV)	Reading Level (dBuV)	Over Limit (dB)	Limit (dBuV)	Probe (dB)	Cable (dB)	Amp (dB)	Type
1	*	0.158	57.123	47.492	-8.649	65.771	9.608	0.022	0.000	QP
2		0.158	46.778	37.147	-8.994	55.771	9.608	0.022	0.000	AV
3		0.206	47.944	38.312	-16.456	64.400	9.601	0.031	0.000	QP
4		0.206	37.843	28.211	-16.557	54.400	9.601	0.031	0.000	AV
5		0.362	41.113	31.478	-18.830	59.943	9.600	0.035	0.000	QP
6		0.362	32.391	22.756	-17.552	49.943	9.600	0.035	0.000	AV
7		2.006	27.683	17.978	-28.317	56.000	9.610	0.095	0.000	QP
8		2.006	18.993	9.288	-27.007	46.000	9.610	0.095	0.000	AV
9		3.494	27.859	18.110	-28.141	56.000	9.635	0.114	0.000	QP
10		3.494	18.035	8.286	-27.965	46.000	9.635	0.114	0.000	AV
11		4.778	27.659	17.862	-28.341	56.000	9.656	0.141	0.000	QP
12		4.778	17.384	7.587	-28.616	46.000	9.656	0.141	0.000	AV

Note:

1. " * ", means this data is the worst emission level.
2. Measurement Level = Reading Level + Factor(Probe+Cable+Amp).

Engineer: LEon	
Site: TR1	Time: 2018/11/16
Limit: FCC_Part15.207_CE_AC Power	Margin: 0
Probe: ENV216_101190(0.009-30MHz)	Polarity: Neutral
EUT: LED lamp (Crystal oscillator: Murata(XRCGB38M400FXH17R0))	Power: AC 120V/60Hz
Note: Mode1: Transmit at 2405MHz by Zigbee	

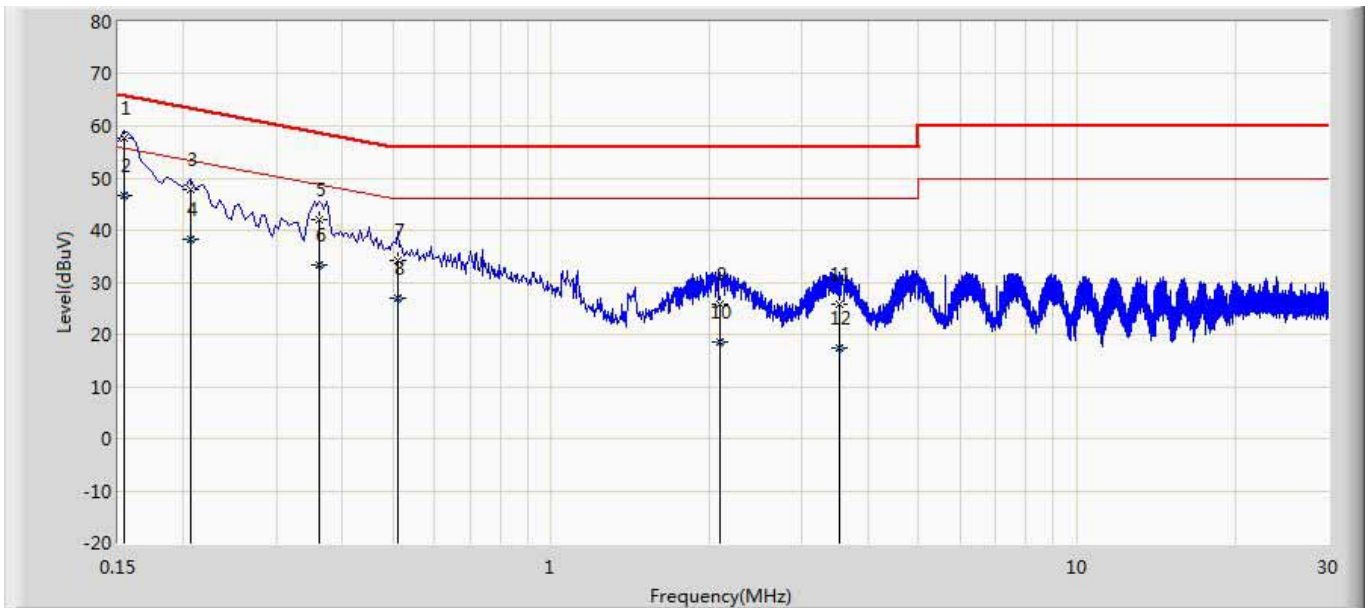

No	Mark	Frequency (MHz)	Measure Level (dBuV)	Reading Level (dBuV)	Over Limit (dB)	Limit (dBuV)	Probe (dB)	Cable (dB)	Amp (dB)	Type
1	*	0.154	57.568	47.954	-8.318	65.886	9.593	0.021	0.000	QP
2		0.154	46.794	37.180	-9.091	55.886	9.593	0.021	0.000	AV
3		0.206	47.874	38.245	-16.526	64.400	9.599	0.031	0.000	QP
4		0.206	38.354	28.724	-16.046	54.400	9.599	0.031	0.000	AV
5		0.362	42.163	32.534	-17.780	59.943	9.594	0.035	0.000	QP
6		0.362	33.375	23.746	-16.568	49.943	9.594	0.035	0.000	AV
7		0.510	34.192	24.570	-21.808	56.000	9.590	0.033	0.000	QP
8		0.510	26.844	17.222	-19.156	46.000	9.590	0.033	0.000	AV
9		2.090	25.658	15.955	-30.342	56.000	9.611	0.092	0.000	QP
10		2.090	18.630	8.927	-27.370	46.000	9.611	0.092	0.000	AV
11		3.538	25.712	15.964	-30.288	56.000	9.631	0.118	0.000	QP
12		3.538	17.397	7.649	-28.603	46.000	9.631	0.118	0.000	AV

Note:

1. " * ", means this data is the worst emission level.
2. Measurement Level = Reading Level + Factor(Probe+Cable+Amp).

4. Emissions in restricted frequency bands

4.1. Test Equipment

Radiated Emission(Below 1GHz) / AC-2				
Instrument	Manufacturer	Type No.	Serial No.	Cal. Due Date
EMI Test Receiver	R&S	ESCI	100573	2019.03.28
Loop Antenna	R&S	HFH2-Z2	833799/003	2019.11.15
Bilog Antenna	Teseq GmbH	CBL6112D	27611	2019.10.15
Coaxial Cable	Huber+Suhner	SUCOFLEX 106	AC2-C	2019.03.01
Temperature/Humidity Meter	Zhichen	ZC1-2	AC2-TH	2019.01.02

Note: All equipment are calibrated with traceable calibrations. Each calibration is traceable to the national or international standards.

Radiated Emission(Above 1GHz) / AC-5				
Instrument	Manufacturer	Type No.	Serial No.	Cal. Due Date
Spectrum Analyzer	Agilent	E4446A	MY45300103	2019.01.03
Preamplifier	Miteq	NSP1800-25	1364185	2019.05.05
Preamplifier	QuieTek	AP-040G	CHM-0906001	2019.05.05
DRG Horn	ETS-Lindgren	3117	00123988	2019.01.21
Broad-Band Horn Antenna	Schwarzbeck	BBHA9170	294	2019.11.24
Coaxial Cable	Huber+Suhner	SUCOFLEX 106	AC5-C1	2019.03.01
Coaxial Cable	Huber+Suhner	SUCOFLEX 106	AC5-C2	2019.03.01
Coaxial Cable	Huber+Suhner	SUCOFLEX 102	AC5-C3	2019.03.01
EMI Receiver	Agilent	N9038A	MY51210196	2019.06.09
Temperature/Humidity Meter	Zhichen	ZC1-2	AC5-TH	2019.01.03

Note: All equipment are calibrated with traceable calibrations. Each calibration is traceable to the national or international standards.

4.2. Test Setup

Below 30MHz Test Setup:

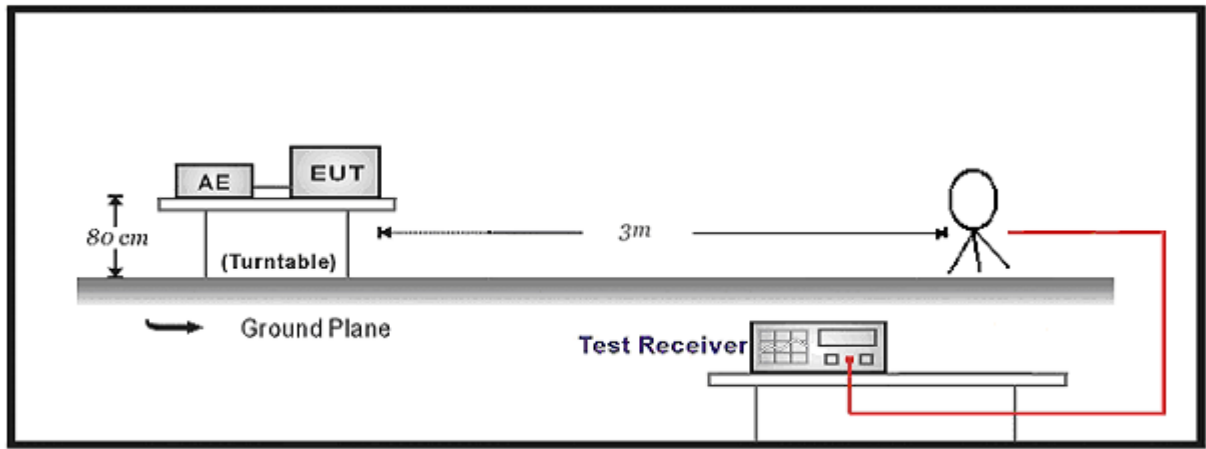

30MHz-1GHz Test Setup:

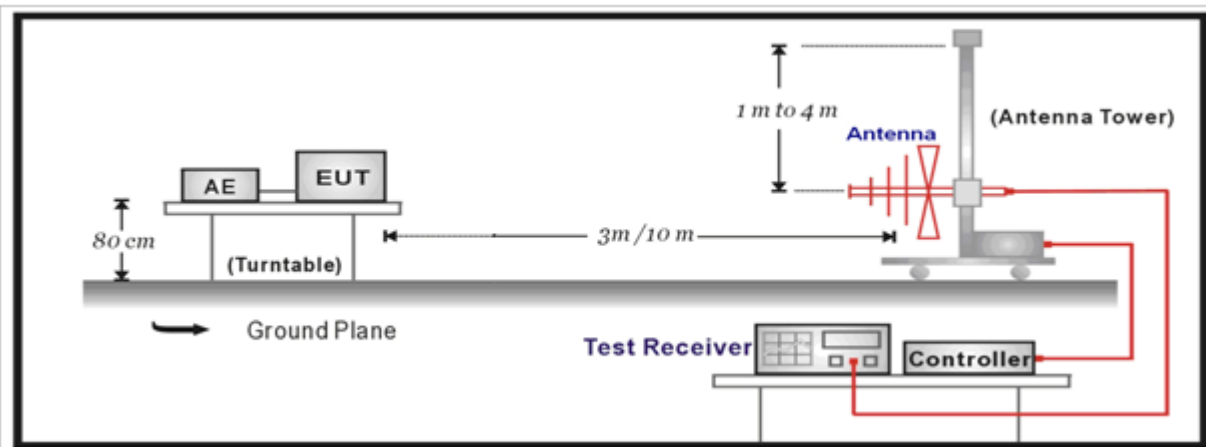

Above 1GHz Test Setup:

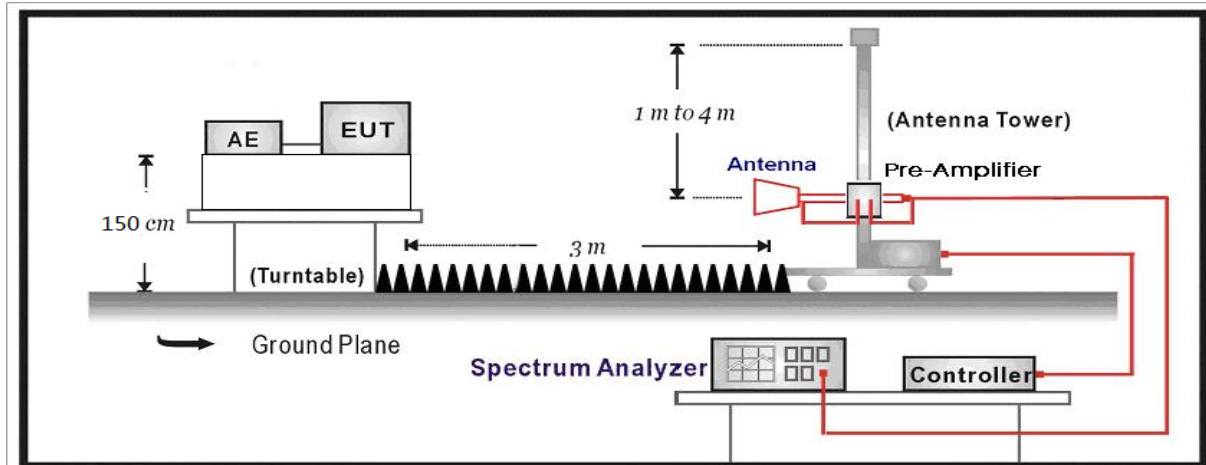

4.3. Limit

For FCC:

Restricted Bands of operation			
Frequency (MHz)	Frequency (MHz)	Frequency (MHz)	Frequency (GHz)
0.090 – 0.110	16.42 – 16.423	399.9 – 410	4.5 – 5.15
0.495 – 0.505	16.69475 – 16.69525	608 – 614	5.35 – 5.46
2.1735 – 2.1905	16.80425 – 16.80475	960 – 1240	7.25 – 7.75
4.125 – 4.128	25.5 – 25.67	1300 – 1427	8.025 – 8.5
4.17725 – 4.17775	37.5 – 38.25	1435 – 1626.5	9.0 – 9.2
4.20725 – 4.20775	73 – 74.6	1645.5 – 1646.5	9.3 – 9.5
6.215 – 6.218	74.8 – 75.2	1660 – 1710	10.6 – 12.7
6.26775 – 6.26825	108 – 121.94	1718.8 – 1722.2	13.25 – 13.4
6.31175 – 6.31225	123 – 138	2200 – 2300	14.47 – 14.5
8.291 – 8.294	149.9 – 150.05	2310 – 2390	15.35 – 16.2
8.362 – 8.366	156.52475 – 156.52525	2483.5 – 2500	17.7 – 21.4
8.37625 – 8.38675	156.7 – 156.9	2690 – 2900	22.01 – 23.12
8.81425 – 8.81475	162.0125 – 167.17	3260 – 3267	23.6 – 24.0
12.29 – 12.293	167.72 – 173.2	3332 – 3339	31.2 – 31.8
12.51975 – 12.52025	240 – 285	3345.8 – 3358	36.43 – 36.5
12.57675 – 12.57725	322 – 335.4	3600 – 4400	
13.36 – 13.41			

For ISED:

Restricted Bands of operation			
Frequency (MHz)	Frequency (MHz)	Frequency (MHz)	Frequency (GHz)
0.090-0.110	13.36-13.41	1645.5-1646.5	9.0-9.2
2.1735-2.1905	16.42-16.423	1660-1710	9.3-9.5
3.020-3.026	16.69475-16.69525	1718.8-1722.2	10.6-12.7
4.125-4.128	16.80425-16.80475	2200-2300	13.25-13.4
4.17725-4.17775	25.5-25.67	2310-2390	14.47-14.5
4.20725-4.20775	37.5-38.25	2655-2900	15.35-16.2
5.677-5.683	73-74.6	3260-3267	17.7-21.4
6.215-6.218	74.8-75.2	3332-3339	22.01-23.12
6.26775-6.26825	108-138	3345.8-3358	23.6-24.0
6.31175-6.31225	156.52475-156.52525	3500-4400	31.2-31.8
8.291-8.294	156.7-156.9	4500-5150	36.43-36.5
8.362-8.366	240-285	5350-5460	Above 38.6
8.37625-8.38675	322-335.4	7250-7750	
8.41425-8.41475	399.9-410	8025-8500	
12.29-12.293	608-614		
12.51975-12.52025	960-1427		
12.57675-12.57725	1435-1626.5		

Restricted Band Emissions Limit			
Frequency (MHz)	Field strength (μ V/m)	Field strength (dB μ V/m)	Measurement distance (m)
0.009 - 0.49	2400/F(kHz)	48.5 – 13.8	300 _(Note 1)
0.49 - 1.705	24000/F(kHz)	33.8 - 23	30 _(Note 1)
1.705 - 30	30	29.5	30 _(Note 1)
30 - 88	100	40	3 _(Note 2)
88 - 216	150	43.5	3 _(Note 2)
216 - 960	200	46	3 _(Note 2)
Above 960	500	54	3 _(Note 2)





Note 1: At frequencies below 30 MHz, measurements may be performed at a distance closer than that specified in the regulations; however, an attempt should be made to avoid making measurements in the near field. Pending the development of an appropriate measurement procedure for measurements performed below 30 MHz, when performing measurements at a closer distance than specified, the results shall be extrapolated to the specified distance by either making measurements at a minimum of two distances on at least one radial to determine the proper extrapolation factor or by using the square of an inverse linear distance extrapolation factor (40 dB/decade).

Note 2: At frequencies at or above 30 MHz, measurements may be performed at a distance other than what is specified provided: measurements are not made in the near field except where it can be shown that near field measurements are appropriate due to the characteristics of the device; and it can be demonstrated that the signal levels needed to be measured at the distance employed can be detected by the measurement equipment. Measurements shall not be performed at a distance greater than 30 meters unless it can be further demonstrated that measurements at a distance of 30 meters or less are impractical. When performing measurements at a distance other than that specified, the results shall be extrapolated to the specified distance using an extrapolation factor of 20 dB/decade (inverse linear-distance for field strength measurements; inverse-linear-distance-squared for power density measurements).

4.4. Test Procedure

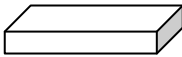
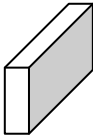
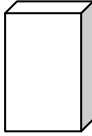
Test Method			
	References Rule	Chapter	Description
<input type="checkbox"/>	ANSI C63.10	11.11	Emissions in non-restricted frequency bands
	<input type="checkbox"/> ANSI C63.10	11.11.2	Reference level measurement
	<input type="checkbox"/> ANSI C63.10	11.11.3	Emission level measurement
<input checked="" type="checkbox"/>	ANSI C63.10	11.12	Emissions in restricted frequency bands
	<input checked="" type="checkbox"/> ANSI C63.10	11.12.1	Radiated emission measurements
	<input checked="" type="checkbox"/> ANSI C63.10	11.12.2.7	Radiated spurious emission test
	<input checked="" type="checkbox"/> ANSI C63.10	6.4	Radiated emissions from unlicensed wireless devices below 30 MHz
	<input checked="" type="checkbox"/> ANSI C63.10	6.5	Radiated emissions from unlicensed wireless devices in the frequency range of 30 MHz to 1000 MHz
	<input checked="" type="checkbox"/> ANSI C63.10	6.6	Radiated emissions from unlicensed wireless devices above 1 GHz
	<input type="checkbox"/> ANSI C63.10	11.12.2.3	Quasi-peak measurement procedure
	<input checked="" type="checkbox"/> ANSI C63.10	11.12.2.4	Peak power measurement procedure
	<input checked="" type="checkbox"/> ANSI C63.10	11.12.2.5	Average power measurement procedures
	<input type="checkbox"/> ANSI C63.10	11.12.2.5.1	Trace averaging with continuous EUT transmission at full power
	<input type="checkbox"/> ANSI C63.10	11.12.2.5.2	Trace averaging across ON and OFF times of the EUT transmissions followed by duty cycle correction
	<input checked="" type="checkbox"/> ANSI C63.10	11.12.2.5.3	Reduced VBW averaging across ON and OFF times of the EUT transmissions with max hold

4.5. EUT test Axis definition

Item	Emissions in restricted frequency bands			
Device Category	<input type="checkbox"/>	Fixed point-to-point		
	<input type="checkbox"/>	Emit multiple directional beams, simultaneously or sequentially		
	<input checked="" type="checkbox"/>	Other cases		
Test mode	Mode 1			
Test method	<input checked="" type="checkbox"/>	Radiated		
		X Axis	Y Axis	Z Axis
				
		Worst Axis <input checked="" type="checkbox"/>	Worst Axis <input type="checkbox"/>	Worst Axis <input type="checkbox"/>
	<input type="checkbox"/>	Conducted		
	<input type="checkbox"/>	Chain 0		
				
	<input type="checkbox"/>	Chain 0	Chain 1	
				
	<input type="checkbox"/>	Chain 0	Chain 1	Chain 2
				

4.6. Test Result

LED lamp (Crystal oscillator: Diode (FL3840023)_2017; Lighting source: LTN)

Engineer: Karl	
Site: AC5	Time: 2018/11/07 - 23:53
Limit: FCC_Part15.209_RE(3m)	Margin: 0
Probe: Horn_3117_00167055(1-18GHz)	Polarity: Vertical
EUT: LED lamp	Power: AC 120V/60Hz
Note: Mode 1:Transmit at 2405MHz by Zigbee LTN	

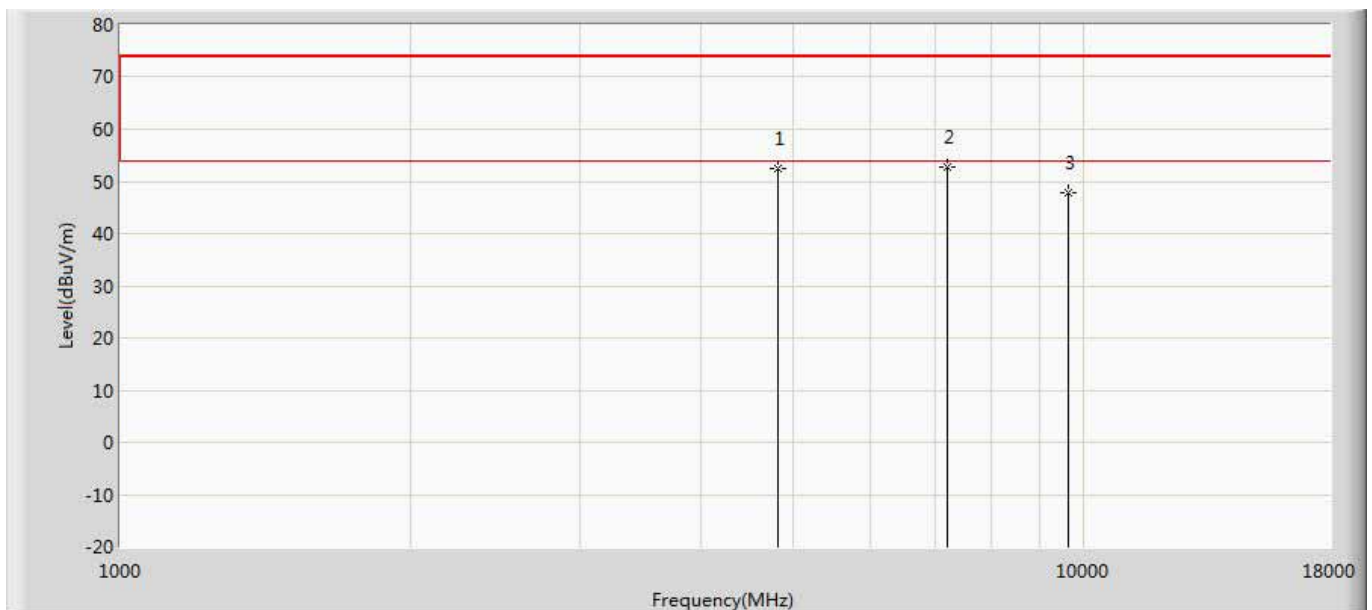

No	Mark	Frequency (MHz)	Measure Level (dBuV/m)	Reading Level (dBuV)	Over Limit (dB)	Limit (dBuV/m)	Factor (dB)	Type
1		4810.000	52.508	52.345	-21.492	74.000	0.162	PK
2	*	7215.000	52.721	49.249	-21.279	74.000	3.472	PK
3		9620.000	47.951	39.518	-26.049	74.000	8.433	PK

Engineer: Karl	
Site: AC5	Time: 2018/11/07 - 23:56
Limit: FCC_Part15.209_RE(3m)	Margin: 0
Probe: Horn_3117_00167055(1-18GHz)	Polarity: Horizontal
EUT: LED lamp	Power: AC 120V/60Hz
Note: Mode 1:Transmit at 2405MHz by Zigbee LTN	

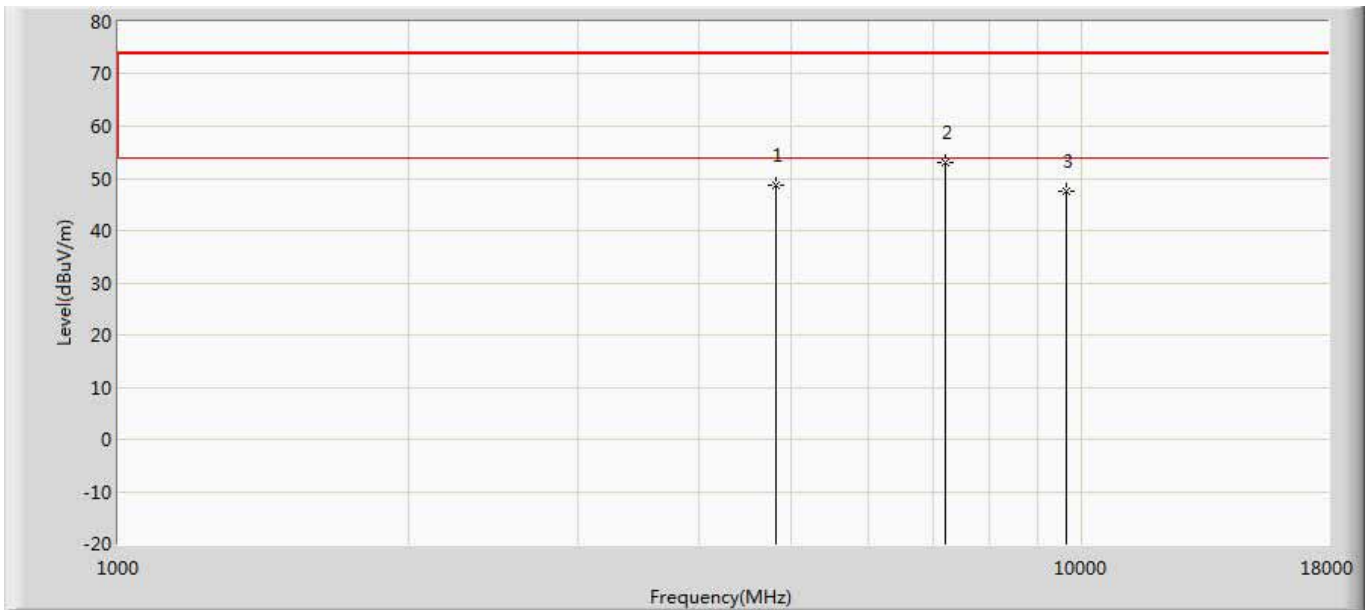

No	Mark	Frequency (MHz)	Measure Level (dBuV/m)	Reading Level (dBuV)	Over Limit (dB)	Limit (dBuV/m)	Factor (dB)	Type
1		4810.000	48.680	48.517	-25.320	74.000	0.162	PK
2	*	7215.000	52.986	49.514	-21.014	74.000	3.472	PK
3		9620.000	47.678	39.245	-26.322	74.000	8.433	PK

Engineer: Karl	
Site: AC5	Time: 2018/11/07 - 23:57
Limit: FCC_Part15.209_RE(3m)	Margin: 0
Probe: Horn_3117_00167055(1-18GHz)	Polarity: Vertical
EUT: LED lamp	Power: AC 120V/60Hz
Note: Mode 1:Transmit at 2450MHz by Zigbee LTN	

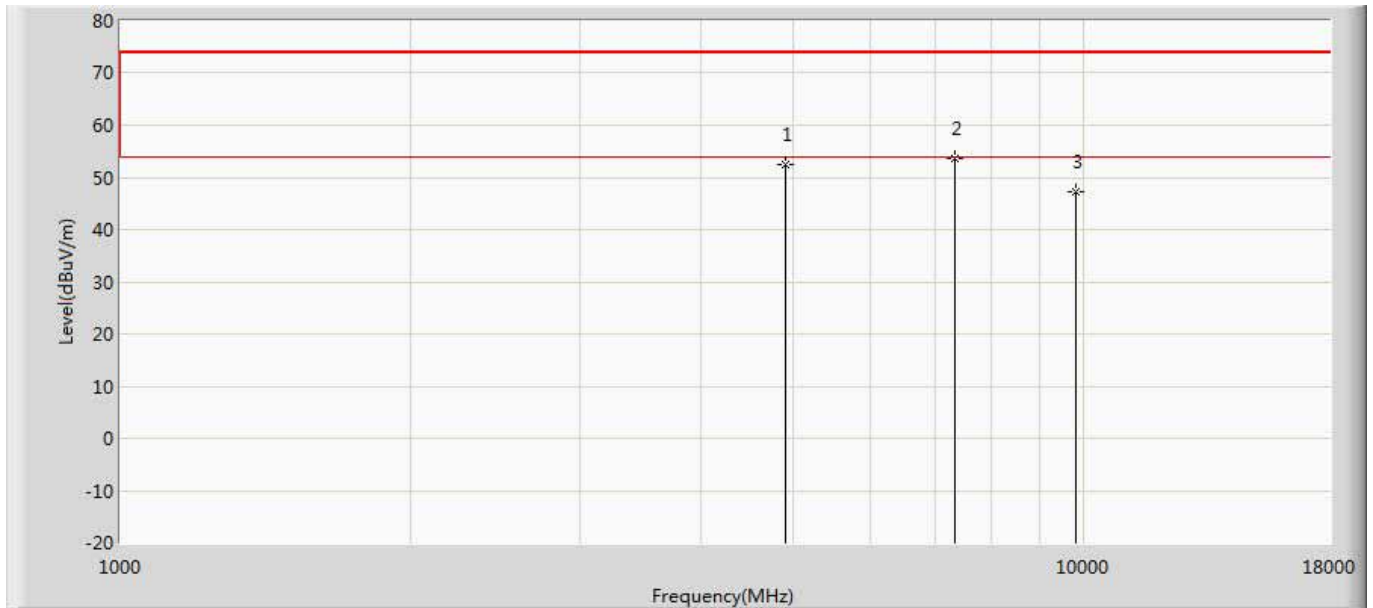

No	Mark	Frequency (MHz)	Measure Level (dBuV/m)	Reading Level (dBuV)	Over Limit (dB)	Limit (dBuV/m)	Factor (dB)	Type
1		4900.000	52.462	52.245	-21.538	74.000	0.216	PK
2	*	7350.000	53.740	49.548	-20.260	74.000	4.192	PK
3		9800.000	47.316	39.652	-26.684	74.000	7.664	PK

Engineer: Karl	
Site: AC5	Time: 2018/11/07 - 23:58
Limit: FCC_Part15.209_RE(3m)	Margin: 0
Probe: Horn_3117_00167055(1-18GHz)	Polarity: Horizontal
EUT: LED lamp	Power: AC 120V/60Hz
Note: Mode 1:Transmit at 2450MHz by Zigbee LTN	

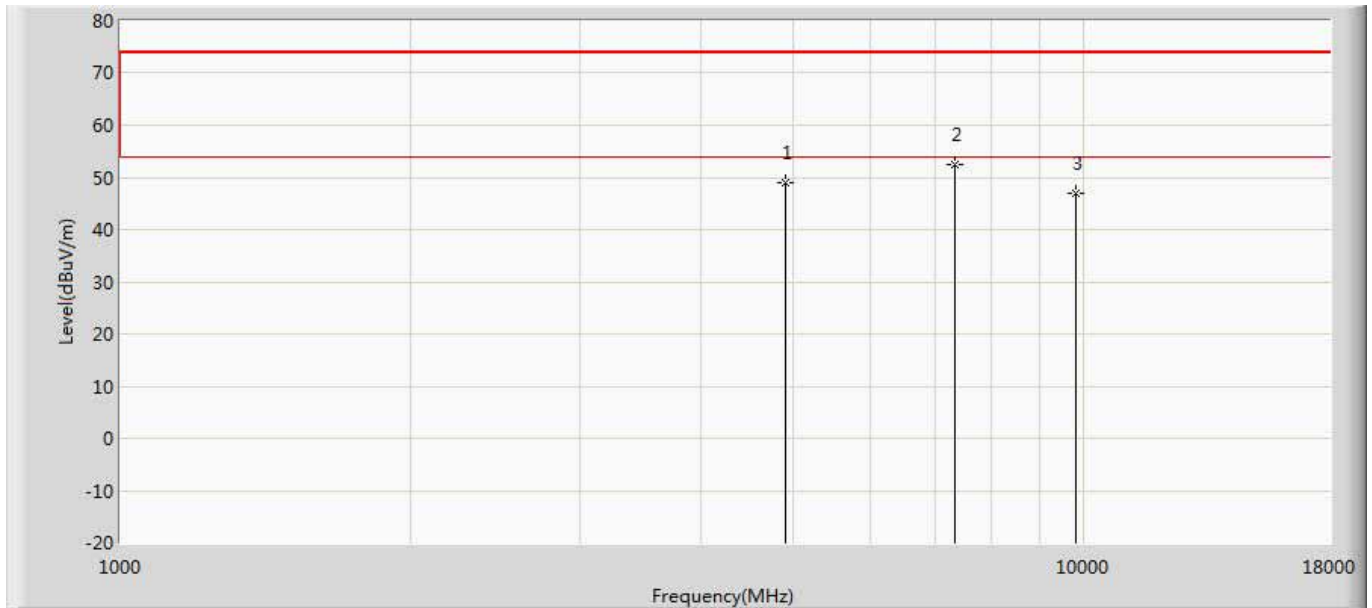

No	Mark	Frequency (MHz)	Measure Level (dBuV/m)	Reading Level (dBuV)	Over Limit (dB)	Limit (dBuV/m)	Factor (dB)	Type
1		4900.000	48.871	48.654	-25.129	74.000	0.216	PK
2	*	7350.000	52.437	48.245	-21.563	74.000	4.192	PK
3		9800.000	46.920	39.256	-27.080	74.000	7.664	PK

Engineer: Karl	
Site: AC5	Time: 2018/11/08 - 00:00
Limit: FCC_Part15.209_RE(3m)	Margin: 0
Probe: Horn_3117_00167055(1-18GHz)	Polarity: Vertical
EUT: LED lamp	Power: AC 120V/60Hz
Note: Mode 1:Transmit at 2480MHz by Zigbee LTN	

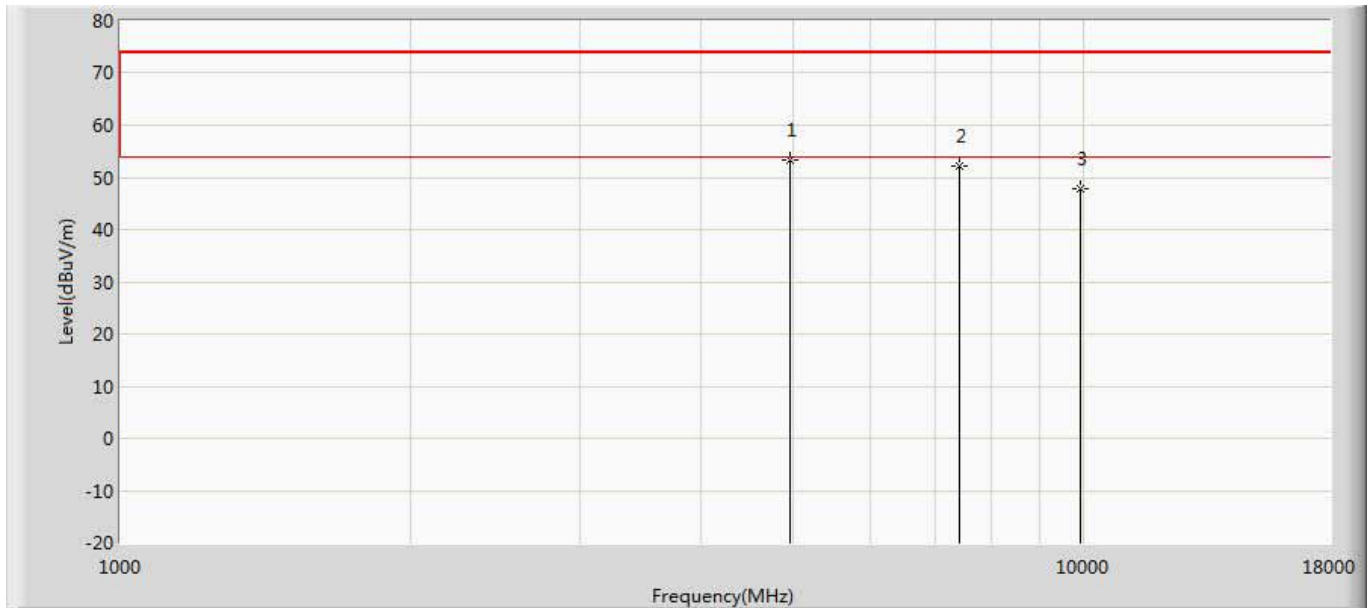

No	Mark	Frequency (MHz)	Measure Level (dBuV/m)	Reading Level (dBuV)	Over Limit (dB)	Limit (dBuV/m)	Factor (dB)	Type
1	*	4960.000	53.325	52.654	-20.675	74.000	0.671	PK
2		7440.000	52.276	47.549	-21.724	74.000	4.727	PK
3		9920.000	47.856	39.455	-26.144	74.000	8.401	PK

Engineer: Karl	
Site: AC5	Time: 2018/11/08 - 00:08
Limit: FCC_Part15.209_RE(3m)	Margin: 0
Probe: Horn_3117_00167055(1-18GHz)	Polarity: Horizontal
EUT: LED lamp	Power: AC 120V/60Hz
Note: Mode 1:Transmit at 2480MHz by Zigbee LTN	

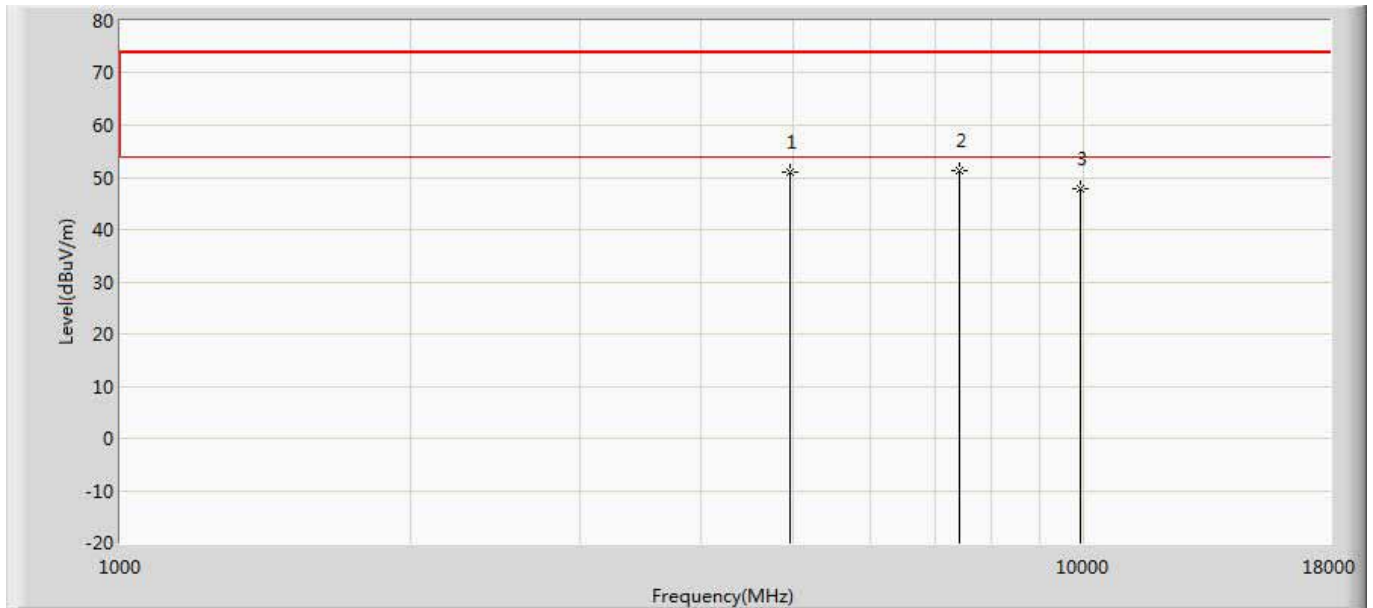

No	Mark	Frequency (MHz)	Measure Level (dBuV/m)	Reading Level (dBuV)	Over Limit (dB)	Limit (dBuV/m)	Factor (dB)	Type
1		4960.000	50.919	50.248	-23.081	74.000	0.671	PK
2	*	7440.000	51.276	46.549	-22.724	74.000	4.727	PK
3		9920.000	47.945	39.544	-26.055	74.000	8.401	PK

LED lamp (Crystal oscillator: Diode (FL3840023)_2017; Lighting source: APT)

Engineer: Karl	
Site: AC5	Time: 2018/11/08 - 00:09
Limit: FCC_Part15.209_RE(3m)	Margin: 0
Probe: Horn_3117_00167055(1-18GHz)	Polarity: Vertical
EUT: LED lamp	Power: AC 120V/60Hz
Note: Mode 1:Transmit at 2405MHz by Zigbee APT	

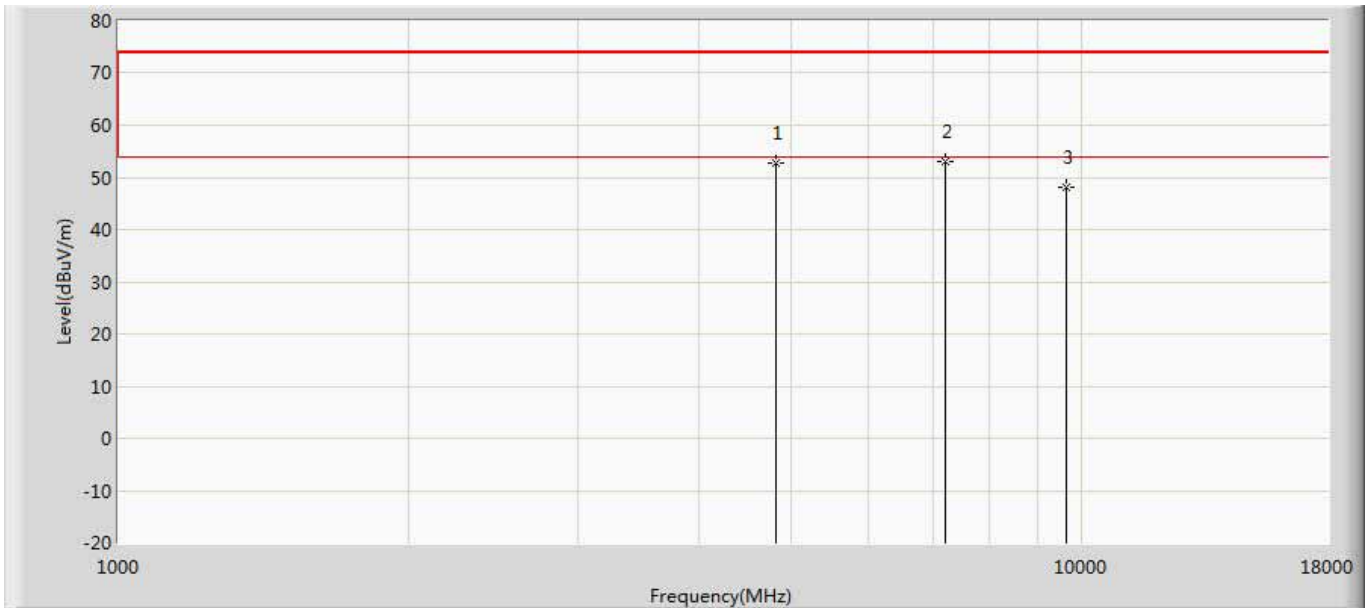

No	Mark	Frequency (MHz)	Measure Level (dBuV/m)	Reading Level (dBuV)	Over Limit (dB)	Limit (dBuV/m)	Factor (dB)	Type
1		4810.000	52.688	52.525	-21.312	74.000	0.162	PK
2	*	7215.000	53.100	49.628	-20.900	74.000	3.472	PK
3		9620.000	48.091	39.658	-25.909	74.000	8.433	PK

Engineer: Karl	
Site: AC5	Time: 2018/11/08 - 00:10
Limit: FCC_Part15.209_RE(3m)	Margin: 0
Probe: Horn_3117_00167055(1-18GHz)	Polarity: Horizontal
EUT: LED lamp	Power: AC 120V/60Hz
Note: Mode 1:Transmit at 2405MHz by Zigbee APT	

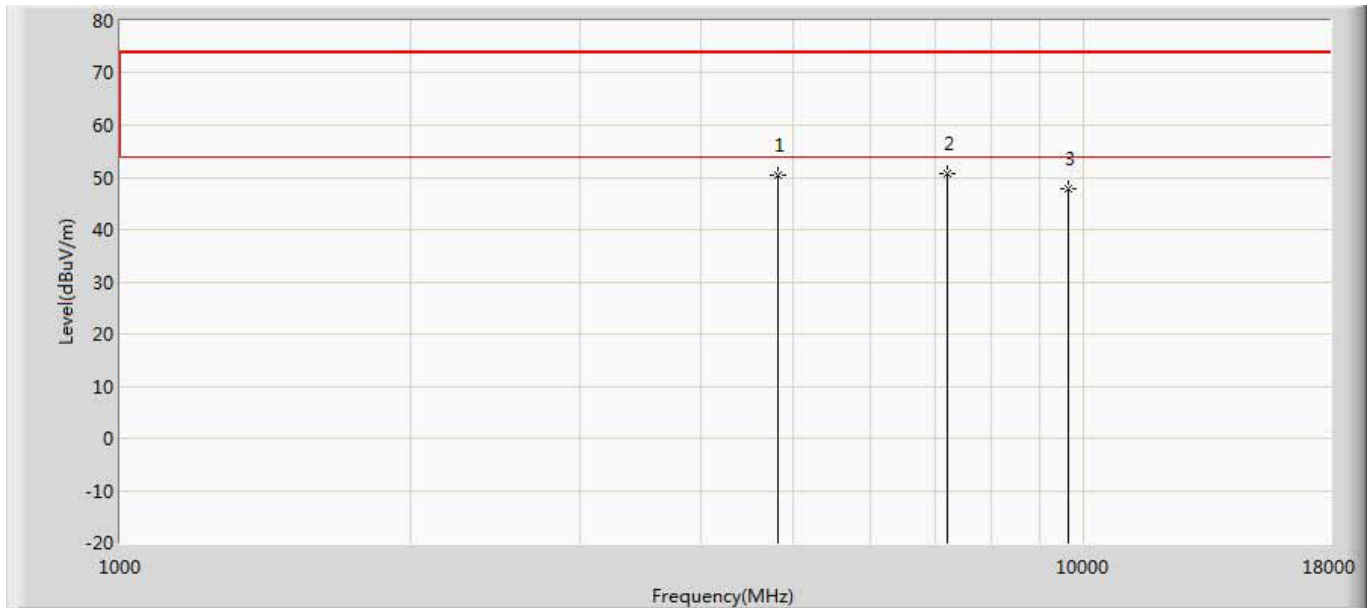

No	Mark	Frequency (MHz)	Measure Level (dBuV/m)	Reading Level (dBuV)	Over Limit (dB)	Limit (dBuV/m)	Factor (dB)	Type
1		4810.000	50.420	50.257	-23.580	74.000	0.162	PK
2	*	7215.000	50.622	47.150	-23.378	74.000	3.472	PK
3		9620.000	47.698	39.265	-26.302	74.000	8.433	PK

Engineer: Karl	
Site: AC5	Time: 2018/11/08 - 00:10
Limit: FCC_Part15.209_RE(3m)	Margin: 0
Probe: Horn_3117_00167055(1-18GHz)	Polarity: Vertical
EUT: LED lamp	Power: AC 120V/60Hz
Note: Mode 1:Transmit at 2450MHz by Zigbee APT	

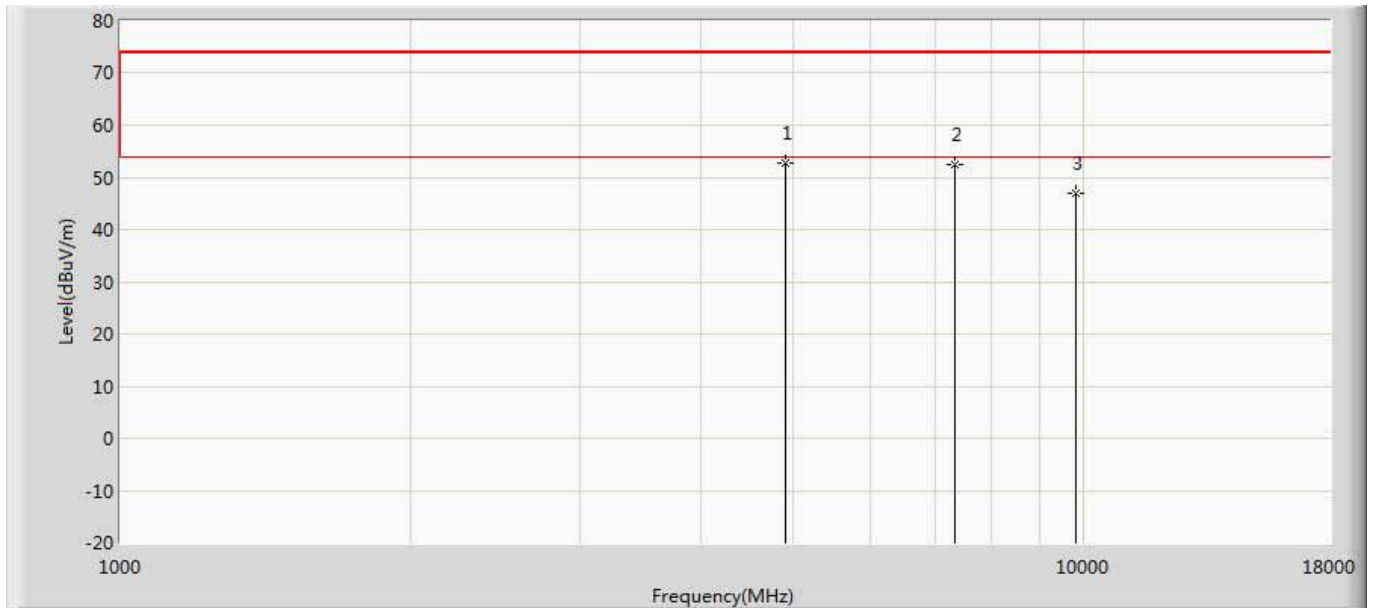

No	Mark	Frequency (MHz)	Measure Level (dBuV/m)	Reading Level (dBuV)	Over Limit (dB)	Limit (dBuV/m)	Factor (dB)	Type
1	*	4900.000	52.675	52.458	-21.325	74.000	0.216	PK
2		7350.000	52.549	48.357	-21.451	74.000	4.192	PK
3		9800.000	46.928	39.264	-27.072	74.000	7.664	PK

Engineer: Karl	
Site: AC5	Time: 2018/11/08 - 00:11
Limit: FCC_Part15.209_RE(3m)	Margin: 0
Probe: Horn_3117_00167055(1-18GHz)	Polarity: Horizontal
EUT: LED lamp	Power: AC 120V/60Hz
Note: Mode 1:Transmit at 2450MHz by Zigbee APT	

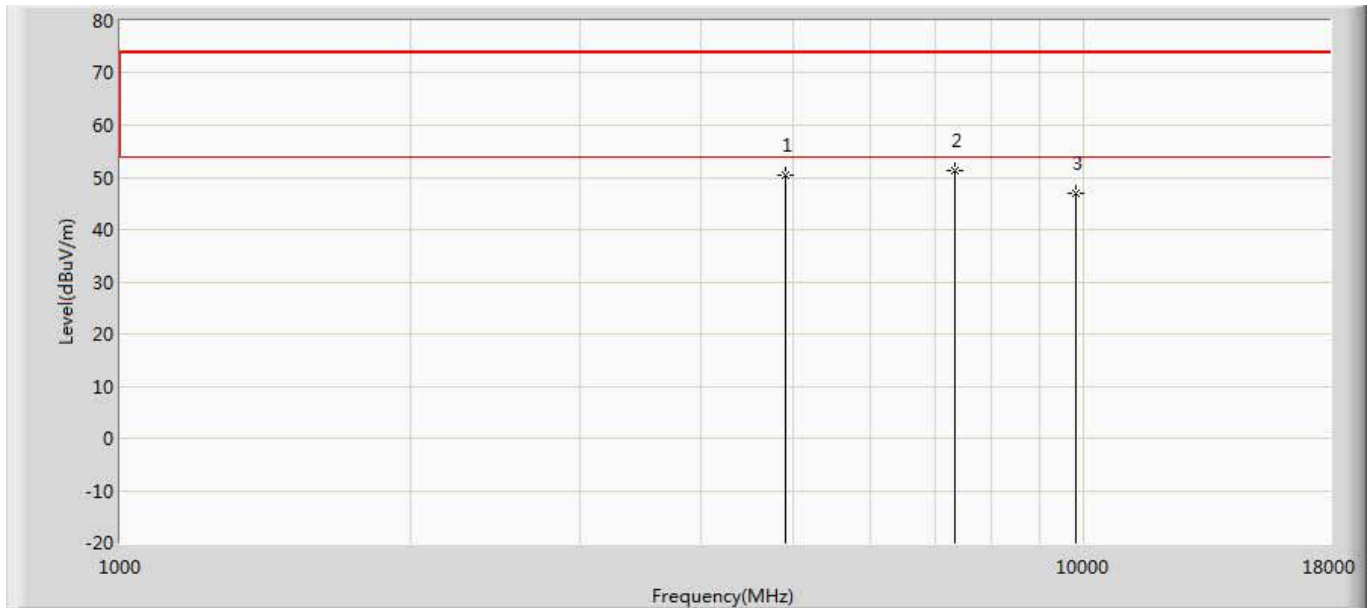

No	Mark	Frequency (MHz)	Measure Level (dBuV/m)	Reading Level (dBuV)	Over Limit (dB)	Limit (dBuV/m)	Factor (dB)	Type
1		4900.000	50.475	50.258	-23.525	74.000	0.216	PK
2	*	7350.000	51.446	47.254	-22.554	74.000	4.192	PK
3		9800.000	46.918	39.254	-27.082	74.000	7.664	PK

Engineer: Karl	
Site: AC5	Time: 2018/11/08 - 00:36
Limit: FCC_Part15.209_RE(3m)	Margin: 0
Probe: Horn_3117_00167055(1-18GHz)	Polarity: Vertical
EUT: LED lamp	Power: AC 120V/60Hz
Note: Mode 1:Transmit at 2480MHz by Zigbee APT	

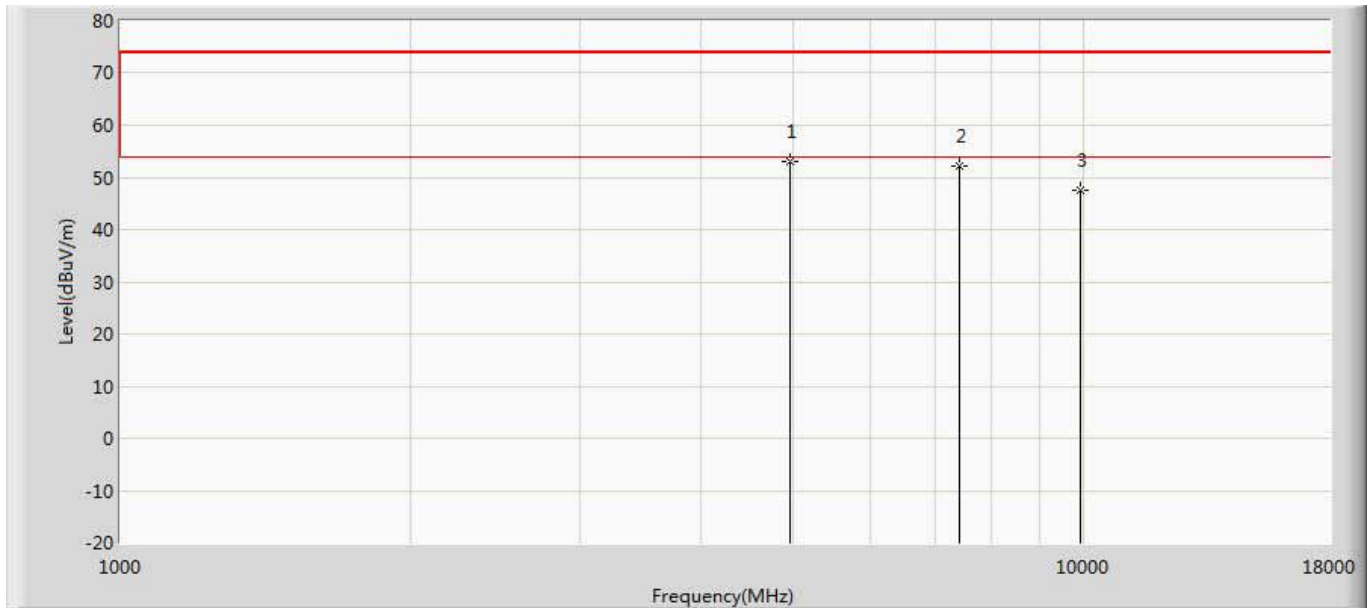

No	Mark	Frequency (MHz)	Measure Level (dBuV/m)	Reading Level (dBuV)	Over Limit (dB)	Limit (dBuV/m)	Factor (dB)	Type
1	*	4960.000	52.920	52.249	-21.080	74.000	0.671	PK
2		7440.000	52.275	47.548	-21.725	74.000	4.727	PK
3		9920.000	47.655	39.254	-26.345	74.000	8.401	PK

Engineer: Karl	
Site: AC5	Time: 2018/11/08 - 00:36
Limit: FCC_Part15.209_RE(3m)	Margin: 0
Probe: Horn_3117_00167055(1-18GHz)	Polarity: Horizontal
EUT: LED lamp	Power: AC 120V/60Hz
Note: Mode 1:Transmit at 2480MHz by Zigbee APT	

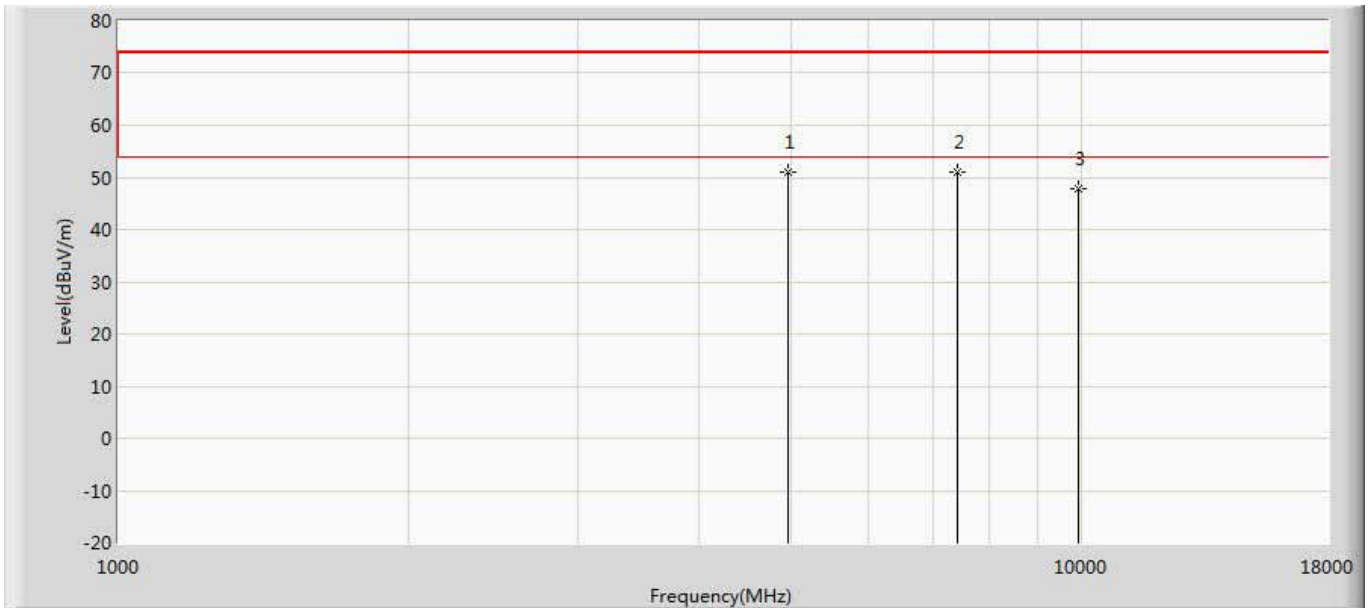

No	Mark	Frequency (MHz)	Measure Level (dBuV/m)	Reading Level (dBuV)	Over Limit (dB)	Limit (dBuV/m)	Factor (dB)	Type
1		4960.000	50.919	50.248	-23.081	74.000	0.671	PK
2	*	7440.000	51.052	46.325	-22.948	74.000	4.727	PK
3		9920.000	47.726	39.325	-26.274	74.000	8.401	PK

Note:

1. Measured Level = Reading Level + Factor.
2. The test frequency range, 9kHz~30MHz, 18GHz~26GHz, both of the worst case are at least 20dB below the limits, therefore no data appear in the report.
3. This limit applies for using average detector, if the test result on peak is lower than average limit, then average measurement needn't be performed.
4. As the radiated emission was performed, so conducted emission was not tested.

The worst case of Radiated Emission below 1GHz:

Engineer: CptJack	
Site: AC2	Time: 2018/12/17
Limit: FCC_Part15.209_RE(3m)	Margin: 0
Probe: AC2_3M(30-1000M)	Polarity: Horizontal
EUT: LED lamp	Power: AC 120V/60Hz
Note: Diode (FL3840023)_2017(APT)	

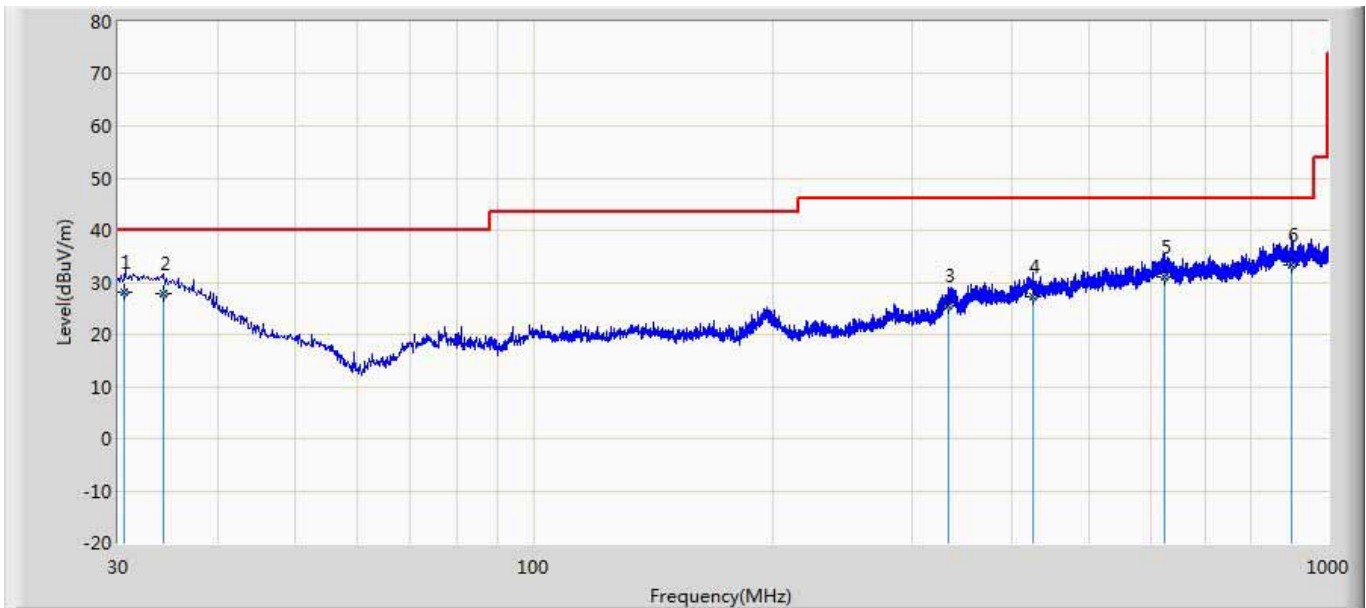

No	Mark	Frequency (MHz)	Measure Level (dBuV/m)	Reading Level (dBuV)	Over Limit (dB)	Limit (dBuV/m)	Probe (dB/m)	Cable (dB)	Amp (dB)	Ant Pos (cm)	Table Pos (deg)	Type
1	*	30.594	28.205	0.600	-11.79	40.000	20.9	6.6	0.0	100	348	QP
					5		79	26	00			
2		34.284	27.754	0.400	-12.24	40.000	20.6	6.6	0.0	100	183	QP
					6		90	64	00			
3		332.25	25.630	2.700	-20.37	46.000	15.2	7.7	0.0	100	311	QP
		6			0		03	27	00			
4		425.20	27.360	0.100	-18.64	46.000	19.2	7.9	0.0	200	104	QP
		7			0		87	72	00			
5		622.29	30.992	0.200	-15.00	46.000	22.2	8.5	0.0	100	197	QP
		4			8		29	63	00			
6		901.56	33.341	0.100	-12.65	46.000	23.9	9.2	0.0	100	214	QP
		4			9		88	53	00			

Note:

1. " * ", means this data is the worst emission level.

2. Measurement Level = Reading Level + Factor(Probe+Cable-Amp).

Engineer: CptJack	
Site: AC2	Time: 2018/12/17
Limit: FCC_Part15.209_RE(3m)	Margin: 0
Probe: AC2_3M(30-1000M)	Polarity: Vertical
EUT: LED lamp	Power: AC 120V/60Hz
Note: Diode (FL3840023)_2017(APT)	

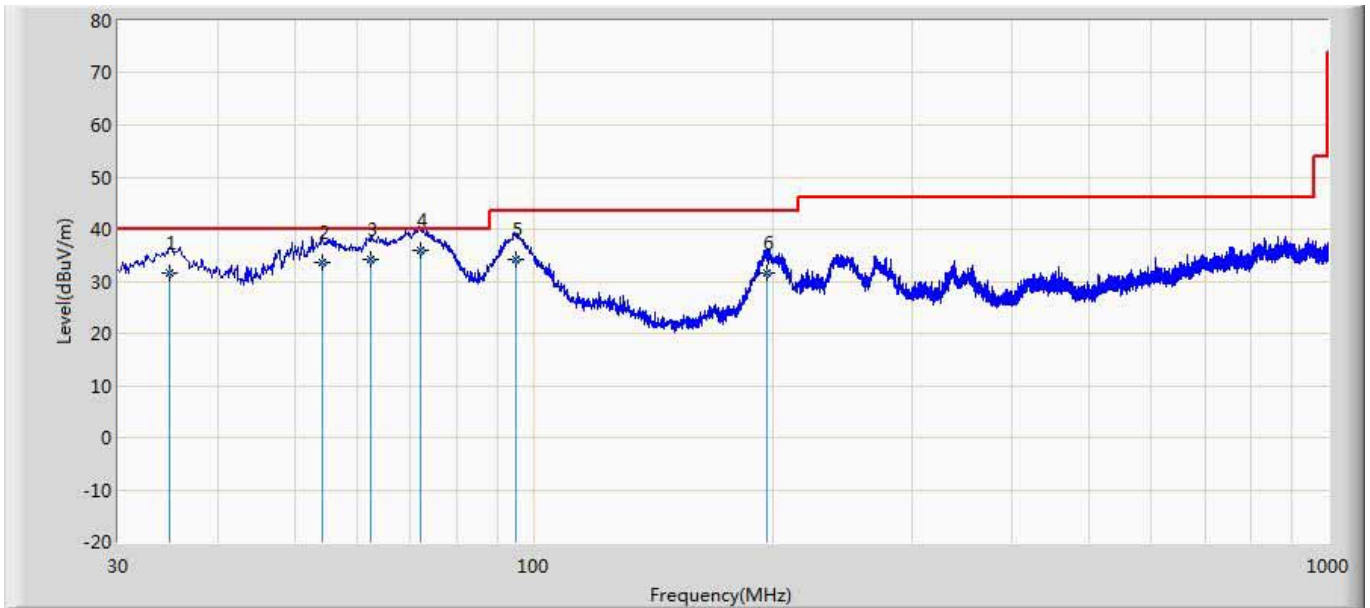

No	Mark	Frequency (MHz)	Measure Level (dBuV/m)	Reading Level (dBuV)	Over Limit (dB)	Limit (dBuV/m)	Probe (dB/m)	Cable (dB)	Amp (dB)	Ant Pos (cm)	Table Pos (deg)	Type
1		34.764	31.680	8.700	-8.320	40.000	16.3	6.6	0.0	100	202	QP
							11	69	00			
2		54.231	33.576	15.700	-6.424	40.000	11.2	6.6	0.0	200	232	QP
							58	18	00			
3		62.294	34.326	18.100	-5.674	40.000	9.51	6.7	0.0	100	208	QP
							5	11	00			
4	*	72.099	35.908	21.400	-4.092	40.000	7.83	6.6	0.0	200	360	QP
							4	74	00			
5		94.864	34.099	14.264	-9.401	43.500	13.0	6.8	0.0	110	360	QP
							28	07	00			
6		196.89	31.509	8.700	-11.99	43.500	15.4	7.3	0.0	100	249	QP
		4			1		74	34	00			

Note:

- " * ", means this data is the worst emission level.
- Measurement Level = Reading Level + Factor(Probe+Cable-Amp).

Engineer: CptJack	
Site: AC2	Time: 2018/12/17 - 16:35
Limit: FCC_Part15.209_RE(3m)	Margin: 0
Probe: AC2_3M(30-1000M)	Polarity: Horizontal
EUT: LED lamp	Power: AC 120V/60Hz
Note: Diode (FL3840023)_2017(LTN)	

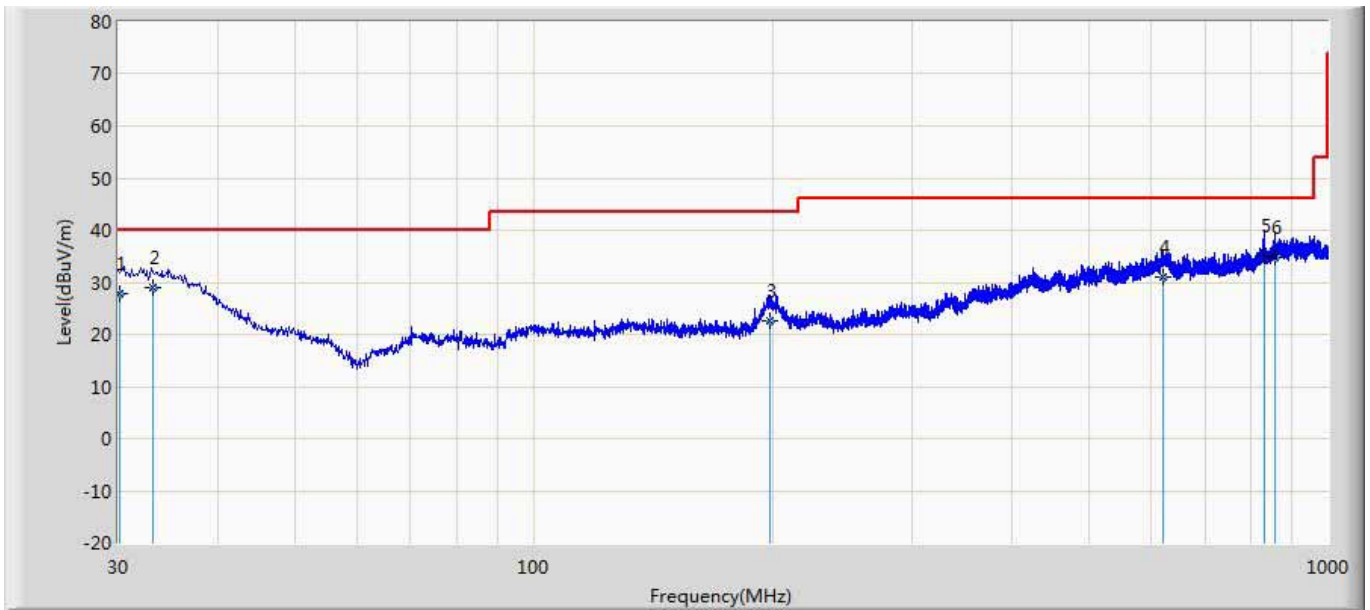

No	Mark	Frequency (MHz)	Measure Level (dBuV/m)	Reading Level (dBuV)	Over Limit (dB)	Limit (dBuV/m)	Probe (dB/m)	Cable (dB)	Amp (dB)	Ant Pos (cm)	Table Pos (deg)	Type
1		30.194	27.970	0.300	-12.03	40.000	21.0	6.6	0.0	200	295	QP
					0		48	22	00			
2		33.201	29.067	1.700	-10.93	40.000	20.7	6.6	0.0	200	311	QP
					3		14	53	00			
3		198.46	22.536	4.700	-20.96	43.500	10.4	7.3	0.0	200	16	QP
		1			4		99	37	00			
4		620.49	31.039	0.200	-14.96	46.000	22.2	8.5	0.0	100	285	QP
		1			1		81	59	00			
5	*	831.11	35.121	3.400	-10.87	46.000	22.6	9.0	0.0	200	213	QP
		4			9		36	85	00			
6		856.18	34.837	2.400	-11.16	46.000	23.2	9.1	0.0	100	154	QP
		4			3		93	44	00			

Note:

1. " * ", means this data is the worst emission level.

2. Measurement Level = Reading Level + Factor(Probe+Cable-Amp).

Engineer: CptJack	
Site: AC2	Time: 2018/12/17
Limit: FCC_Part15.209_RE(3m)	Margin: 0
Probe: AC2_3M(30-1000M)	Polarity: Vertical
EUT: LED lamp	Power: AC 120V/60Hz
Note: Diode (FL3840023)_2017(LTN)	

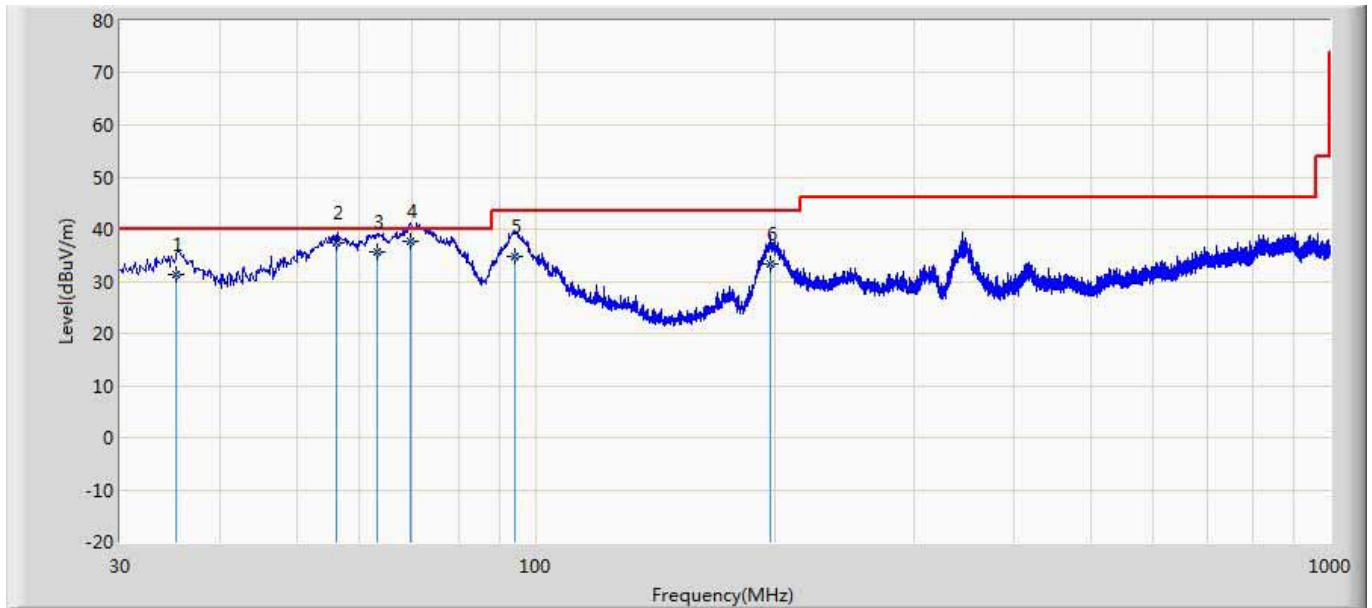

No	Mark	Frequency (MHz)	Measure Level (dBuV/m)	Reading Level (dBuV)	Over Limit (dB)	Limit (dBuV/m)	Probe (dB/m)	Cable (dB)	Amp (dB)	Ant Pos (cm)	Table Pos (deg)	Type
1		35.296	31.256	8.600	-8.744	40.000	15.9 95	6.6 61	0.0 00	200	107	QP
2		56.265	37.315	20.100	-2.685	40.000	10.5 62	6.6 53	0.0 00	100	164	QP
3		63.285	35.529	19.400	-4.471	40.000	9.42 3	6.7 07	0.0 00	200	201	QP
4	*	69.527	37.605	22.500	-2.395	40.000	8.42 4	6.6 81	0.0 00	178	360	QP
5		94.231	34.701	15.200	-8.799	43.500	12.7 02	6.8 00	0.0 00	100	34	QP
6		197.86 0	33.252	10.200	-10.24 8	43.500	15.7 16	7.3 36	0.0 00	100	241	QP

Note:

- " * ", means this data is the worst emission level.
- Measurement Level = Reading Level + Factor(Probe+Cable-Amp).

LED lamp (Crystal oscillator: Murata(XRCGB38M400FXH17R0))

Engineer: Karl	
Site: AC5	Time: 2018/11/07 - 23:53
Limit: FCC_Part15.209_RE(3m)	Margin: 0
Probe: Horn_3117_00167055(1-18GHz)	Polarity: Vertical
EUT: LED lamp	Power: AC 120V/60Hz
Note: Mode 1:Transmit at 2405MHz by Zigbee	

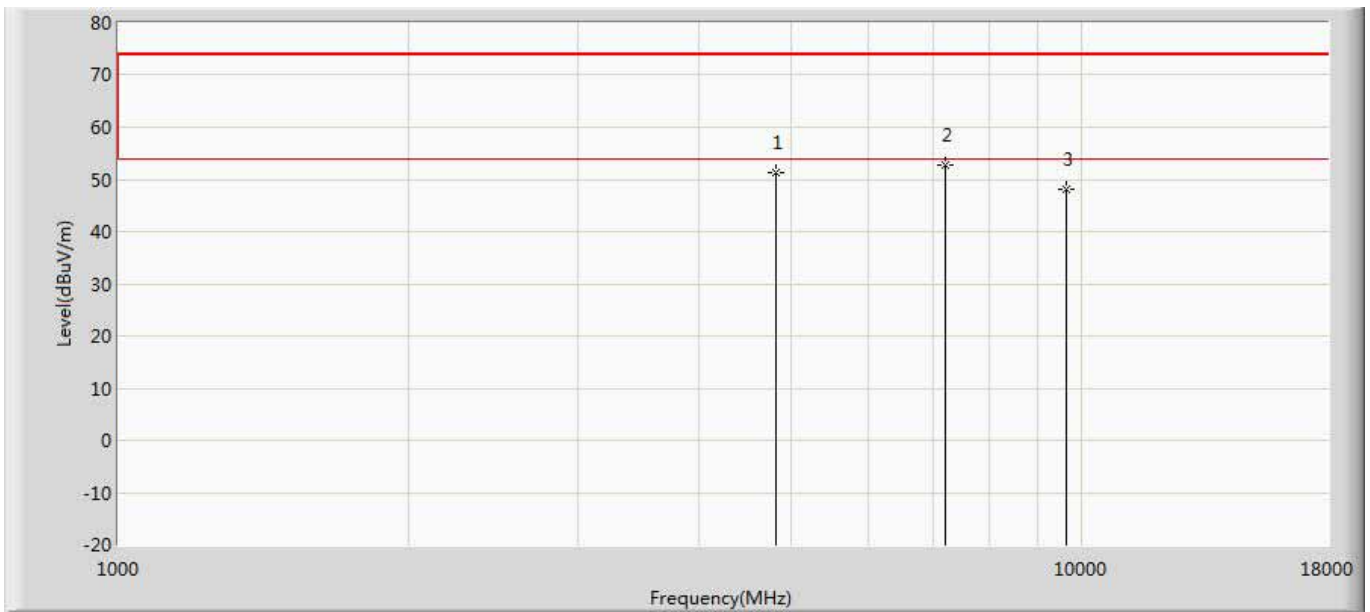

No	Mark	Frequency (MHz)	Measure Level (dBuV/m)	Reading Level (dBuV)	Over Limit (dB)	Limit (dBuV/m)	Factor (dB)	Type
1		4810.000	51.427	51.264	-22.573	74.000	0.162	PK
2	*	7215.000	52.721	49.249	-21.279	74.000	3.472	PK
3		9620.000	48.083	39.650	-25.917	74.000	8.433	PK

Engineer: Karl	
Site: AC5	Time: 2018/11/07 - 23:56
Limit: FCC_Part15.209_RE(3m)	Margin: 0
Probe: Horn_3117_00167055(1-18GHz)	Polarity: Horizontal
EUT: LED lamp	Power: AC 120V/60Hz
Note: Mode 1:Transmit at 2405MHz by Zigbee	

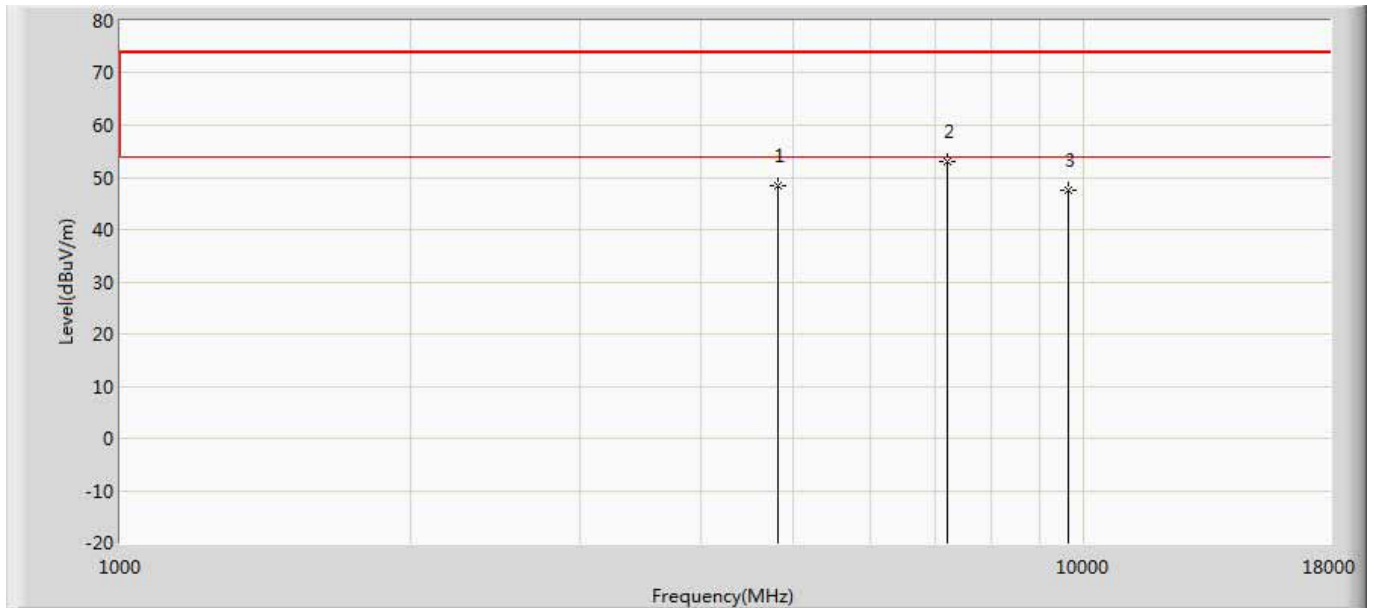

No	Mark	Frequency (MHz)	Measure Level (dBuV/m)	Reading Level (dBuV)	Over Limit (dB)	Limit (dBuV/m)	Factor (dB)	Type
1		4810.000	48.520	48.357	-25.480	74.000	0.162	PK
2	*	7215.000	52.904	49.432	-21.096	74.000	3.472	PK
3		9620.000	47.620	39.187	-26.380	74.000	8.433	PK

Engineer: Karl	
Site: AC5	Time: 2018/11/07 - 23:57
Limit: FCC_Part15.209_RE(3m)	Margin: 0
Probe: Horn_3117_00167055(1-18GHz)	Polarity: Vertical
EUT: LED lamp	Power: AC 120V/60Hz
Note: Mode 1:Transmit at 2450MHz by Zigbee	

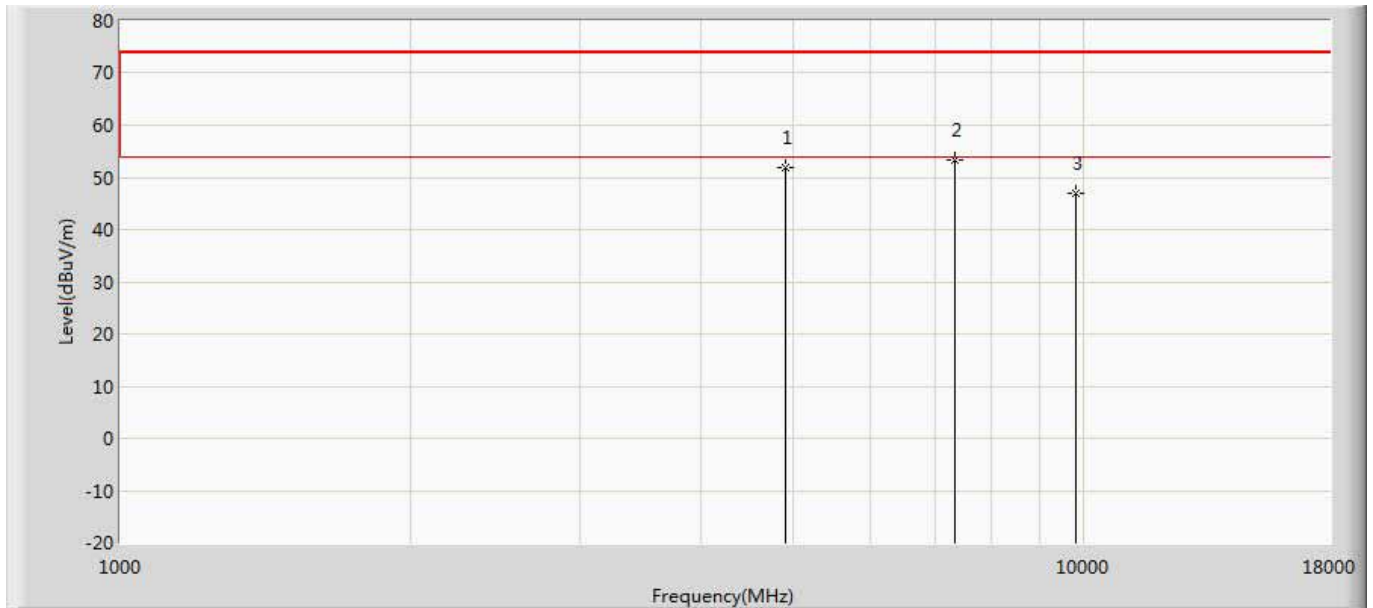

No	Mark	Frequency (MHz)	Measure Level (dBuV/m)	Reading Level (dBuV)	Over Limit (dB)	Limit (dBuV/m)	Factor (dB)	Type
1		4900.000	51.875	51.658	-22.125	74.000	0.216	PK
2	*	7350.000	53.446	49.254	-20.554	74.000	4.192	PK
3		9800.000	46.928	39.264	-27.072	74.000	7.664	PK

Engineer: Karl	
Site: AC5	Time: 2018/11/07 - 23:58
Limit: FCC_Part15.209_RE(3m)	Margin: 0
Probe: Horn_3117_00167055(1-18GHz)	Polarity: Horizontal
EUT: LED lamp	Power: AC 120V/60Hz
Note: Mode 1:Transmit at 2450MHz by Zigbee	

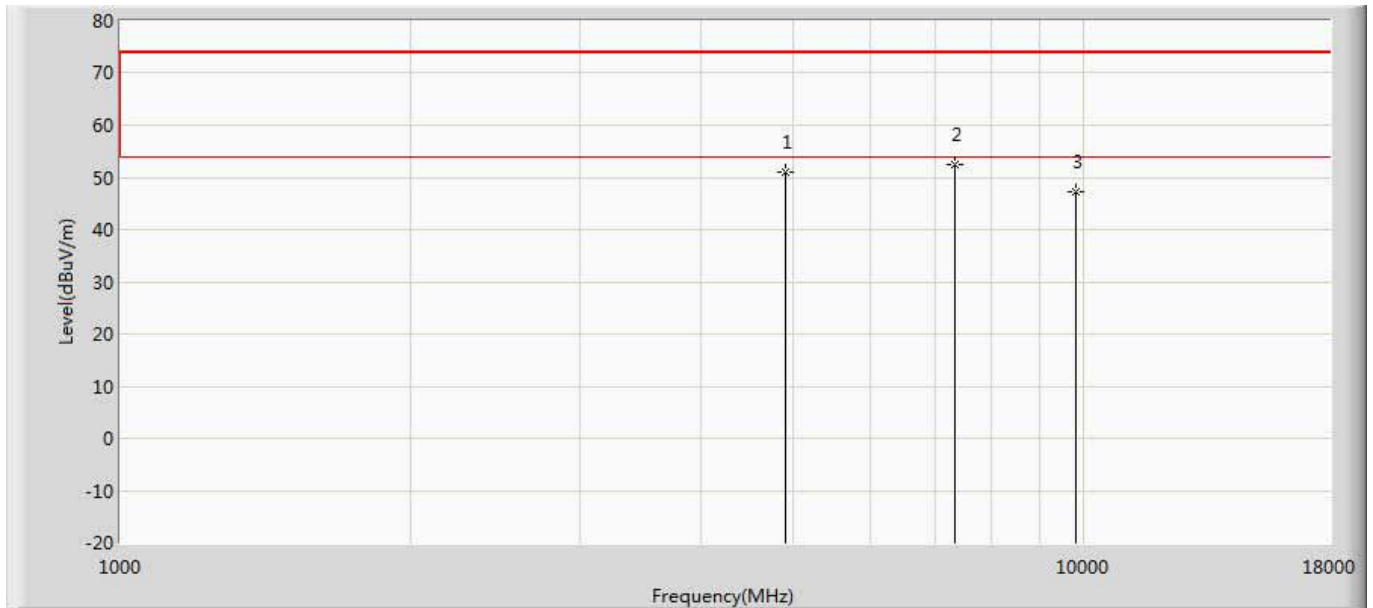

No	Mark	Frequency (MHz)	Measure Level (dBuV/m)	Reading Level (dBuV)	Over Limit (dB)	Limit (dBuV/m)	Factor (dB)	Type
1		4900.000	50.875	50.658	-23.125	74.000	0.216	PK
2	*	7350.000	52.543	48.351	-21.457	74.000	4.192	PK
3		9800.000	47.182	39.518	-26.818	74.000	7.664	PK

Engineer: Karl	
Site: AC5	Time: 2018/11/08 - 00:00
Limit: FCC_Part15.209_RE(3m)	Margin: 0
Probe: Horn_3117_00167055(1-18GHz)	Polarity: Vertical
EUT: LED lamp	Power: AC 120V/60Hz
Note: Mode 1:Transmit at 2480MHz by Zigbee	

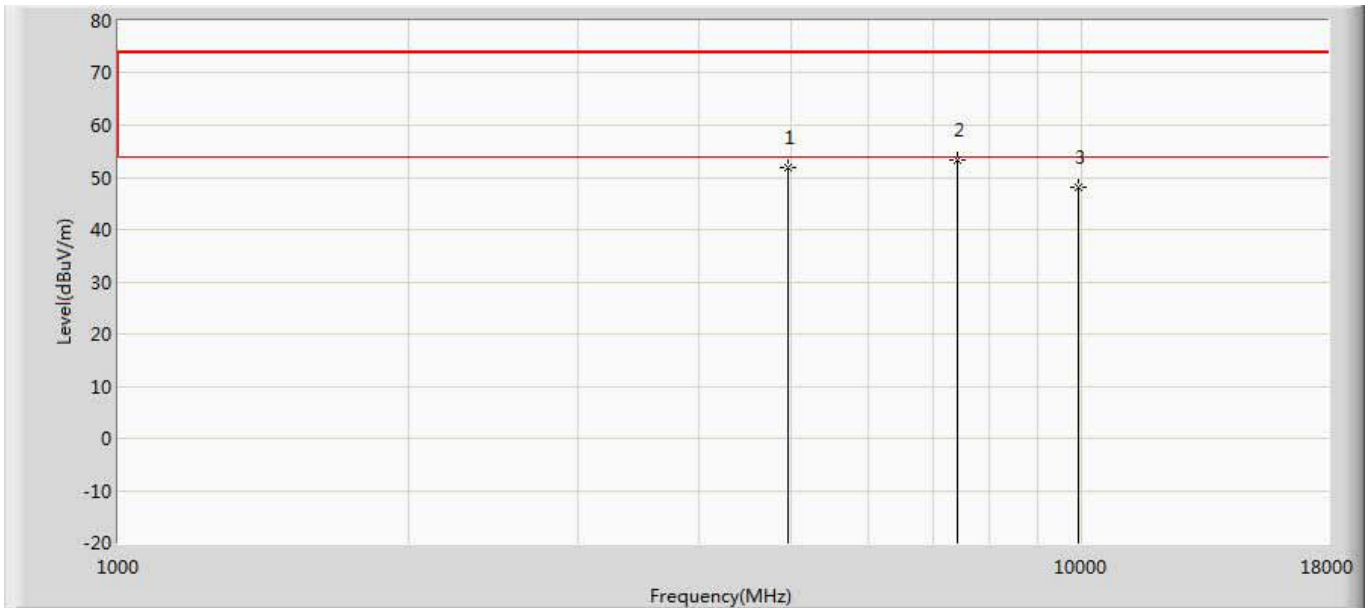

No	Mark	Frequency (MHz)	Measure Level (dBuV/m)	Reading Level (dBuV)	Over Limit (dB)	Limit (dBuV/m)	Factor (dB)	Type
1		4960.000	51.936	51.265	-22.064	74.000	0.671	PK
2	*	7440.000	53.382	48.655	-20.618	74.000	4.727	PK
3		9920.000	48.060	39.659	-25.940	74.000	8.401	PK

Engineer: Karl	
Site: AC5	Time: 2018/11/08 - 00:08
Limit: FCC_Part15.209_RE(3m)	Margin: 0
Probe: Horn_3117_00167055(1-18GHz)	Polarity: Horizontal
EUT: LED lamp	Power: AC 120V/60Hz
Note: Mode 1:Transmit at 2480MHz by Zigbee	

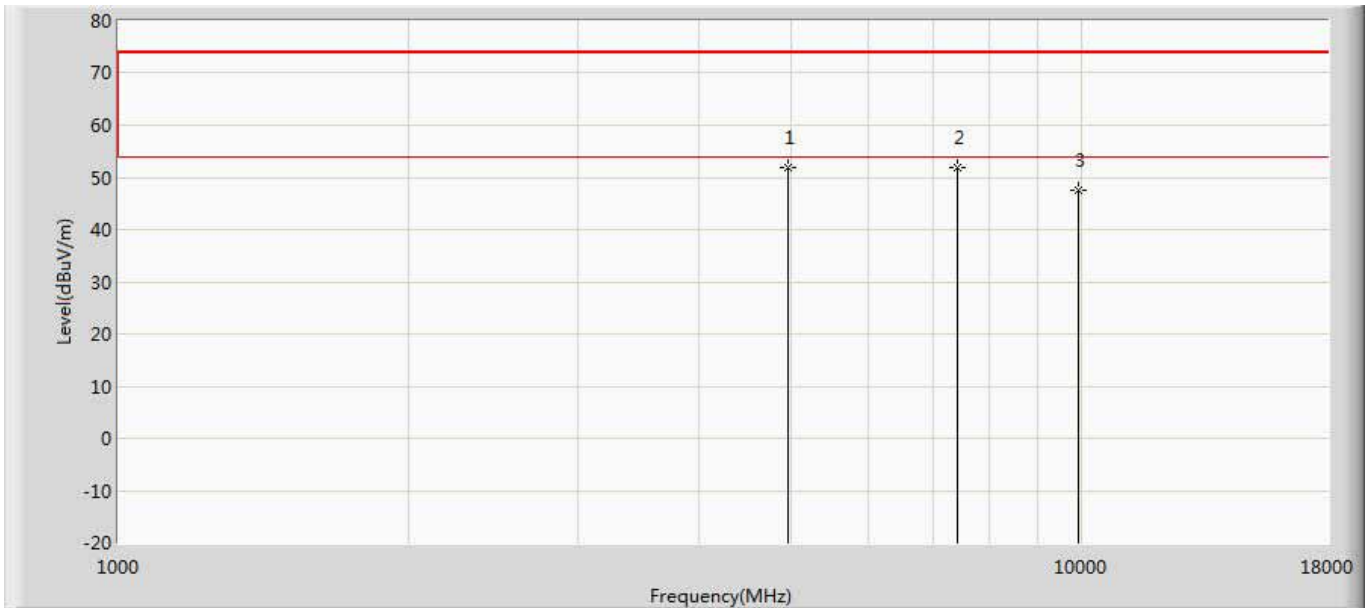

No	Mark	Frequency (MHz)	Measure Level (dBuV/m)	Reading Level (dBuV)	Over Limit (dB)	Limit (dBuV/m)	Factor (dB)	Type
1	*	4960.000	51.997	51.326	-22.003	74.000	0.671	PK
2		7440.000	51.992	47.265	-22.008	74.000	4.727	PK
3		9920.000	47.665	39.264	-26.335	74.000	8.401	PK

Note:

1. Measured Level = Reading Level + Factor.
2. The test frequency range, 9kHz~30MHz, 18GHz~26GHz, both of the worst case are at least 20dB below the limits, therefore no data appear in the report.
3. This limit applies for using average detector, if the test result on peak is lower than average limit, then average measurement needn't be performed.
4. As the radiated emission was performed, so conducted emission was not tested.

The worst case of Radiated Emission below 1GHz:

Engineer: CptJack	
Site: AC2	Time: 2018/12/17
Limit: FCC_Part15.209_RE(3m)	Margin: 0
Probe: AC2_3M(30-1000M)	Polarity: Horizontal
EUT: LED lamp	Power: AC 120V/60Hz
Note: Murata(XRCGB38M400FXH17R0)	

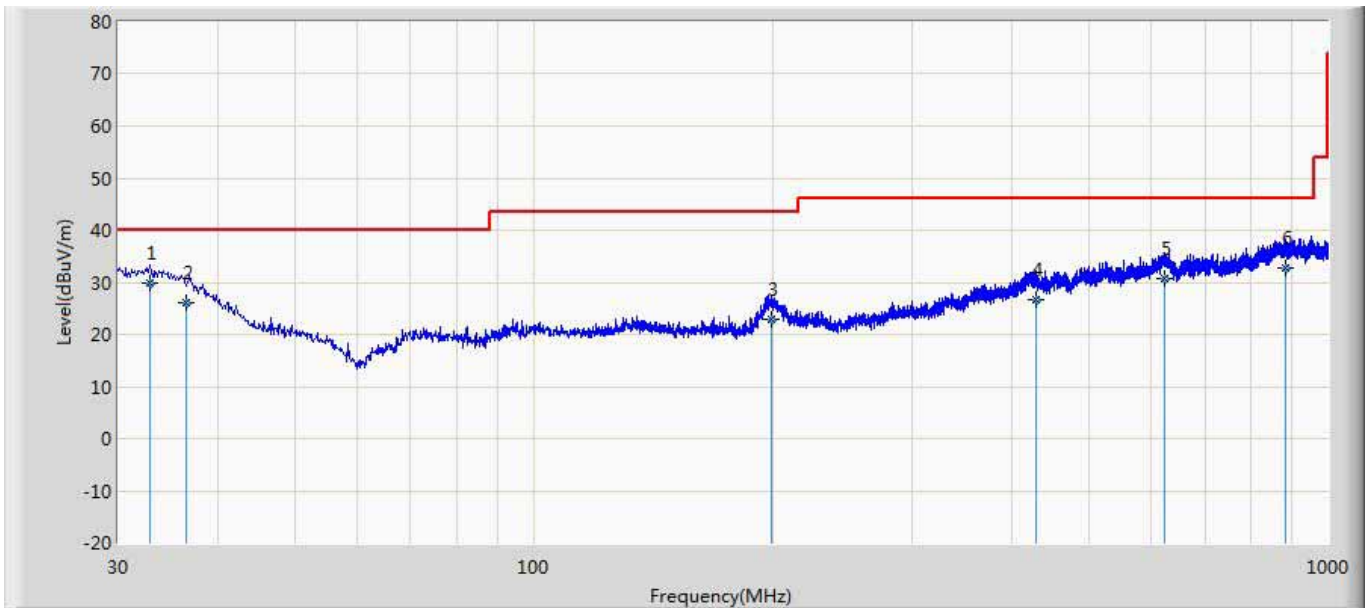

No	Mark	Frequency (MHz)	Measure Level (dBuV/m)	Reading Level (dBuV)	Over Limit (dB)	Limit (dBuV/m)	Probe (dB/m)	Cable (dB)	Amp (dB)	Ant Pos (cm)	Table Pos (deg)	Type
1	*	32.897	29.869	2.500	-10.13	40.000	20.7	6.6	0.0	200	52	QP
2		36.562	26.093	0.300	-13.90	40.000	19.1	6.6	0.0	100	38	QP
3		199.53	22.804	4.900	-20.69	43.500	10.5	7.3	0.0	100	201	QP
4		429.52	26.810	0.300	-19.19	46.000	18.5	7.9	0.0	200	277	QP
5		623.13	30.865	0.100	-15.13	46.000	22.2	8.5	0.0	200	142	QP
6		883.72	32.823	0.200	-13.17	46.000	23.4	9.2	0.0	100	295	QP

Note:

1. " * ", means this data is the worst emission level.

2. Measurement Level = Reading Level + Factor(Probe+Cable-Amp).

Engineer: CptJack	
Site: AC2	Time: 2018/12/17
Limit: FCC_Part15.209_RE(3m)	Margin: 0
Probe: AC2_3M(30-1000M)	Polarity: Vertical
EUT: LED lamp	Power: AC 120V/60Hz
Note: Murata(XRCGB38M400FXH17R0)	

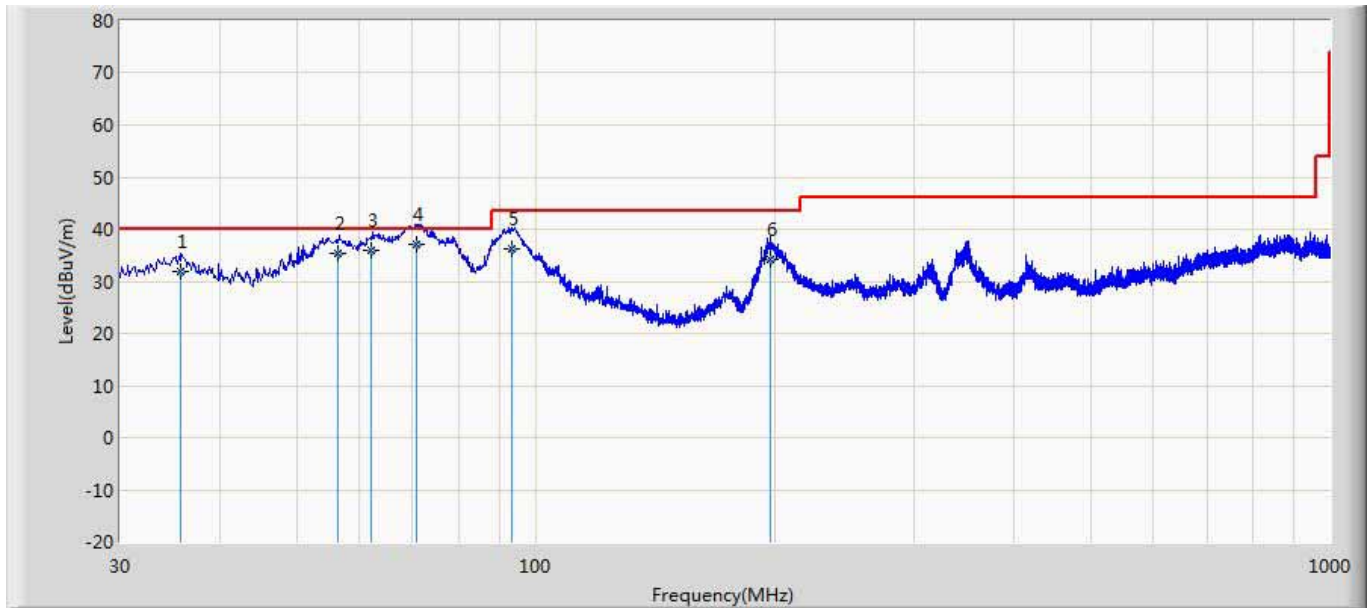

No	Mark	Frequency (MHz)	Measure Level (dBuV/m)	Reading Level (dBuV)	Over Limit (dB)	Limit (dBuV/m)	Probe (dB/m)	Cable (dB)	Amp (dB)	Ant Pos (cm)	Table Pos (deg)	Type
1		35.714	31.772	9.400	-8.228	40.000	15.7 20	6.6 52	0.0 00	200	33	QP
2		56.461	35.365	18.200	-4.635	40.000	10.5 09	6.6 57	0.0 00	200	347	QP
3		62.232	35.933	19.700	-4.067	40.000	9.52 1	6.7 11	0.0 00	200	155	QP
4	*	70.861	37.201	22.400	-2.799	40.000	8.12 4	6.6 77	0.0 00	167	360	QP
5		93.164	36.198	17.400	-7.302	43.500	12.0 11	6.7 86	0.0 00	100	16	QP
6		197.26 0	34.101	11.200	-9.399	43.500	15.5 66	7.3 35	0.0 00	200	352	QP

Note:

1. " * ", means this data is the worst emission level.
2. Measurement Level = Reading Level + Factor(Probe+Cable-Amp).

5. Emissions in non-restricted frequency bands

5.1. Test Equipment

Emissions in non-restricted frequency bands / TR-8					
Instrument	Manufacturer	Type No.	Serial No.	Cal. Date	Cal. Due Date
Spectrum Analyzer	Agilent	N9010A	MY48030494	2018.02.04	2019.02.03
EXA Spectrum Analyzer	Keysight	N9010A	MY55370495	2018.04.09	2019.04.08
MXA Signal Analyzer	Keysight	N9020A	MY56060147	2018.04.09	2019.04.08
Temperature/Humidity Meter	zhichen	ZC1-2	TR8-TH	2018.04.10	2019.04.09

Note: All equipment are calibrated with traceable calibrations. Each calibration is traceable to the national or international standards.

5.2. Test Setup

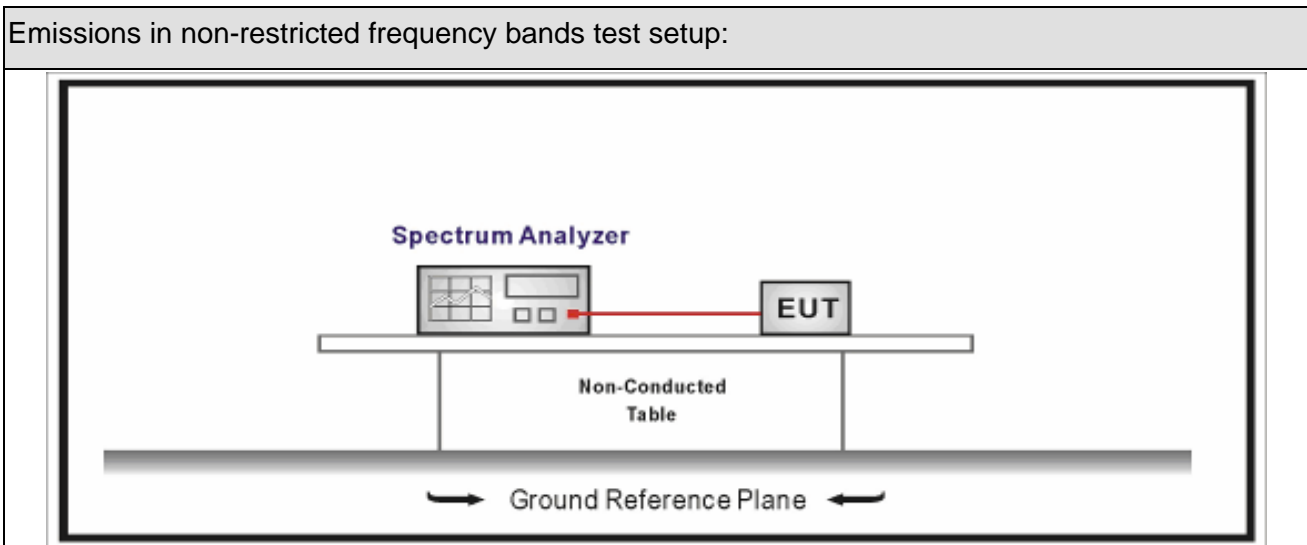





5.3. Limit

Un-Restricted Band Emissions Limit	
RF Output power (Detection methods)	Limit(dB)
RF Output power(Average detector)	30c(Note1)
RF Output power(PK detector)	20c(Note2)
<p>Note 1: If maximum conducted (average) output power was used to demonstrate compliance as described in 9.2, then the peak power in any 100 kHz bandwidth outside of the authorized frequency band shall be attenuated by at least 30 dB relative to the maximum in-band peak PSD level in 100 kHz (i.e., 30 dBc).</p> <p>Note 2: If the maximum peak conducted output power procedure was used, then the peak output power measured in any 100 kHz bandwidth outside of the authorized frequency band shall be attenuated by at least 20 dB relative to the maximum in-band peak PSD level in 100 kHz (i.e., 20 dBc).</p>	

5.4. Test Procedure

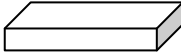
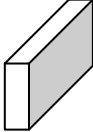
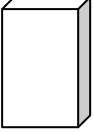
Test Method			
	References Rule	Chapter	Description
<input checked="" type="checkbox"/>	ANSI C63.10	11.11	Emissions in non-restricted frequency bands
	<input checked="" type="checkbox"/> ANSI C63.10	11.11.2	Reference level measurement
	<input checked="" type="checkbox"/> ANSI C63.10	11.11.3	Emission level measurement
<input type="checkbox"/>	ANSI C63.10	11.12	Emissions in restricted frequency bands
	<input type="checkbox"/> ANSI C63.10	11.12.1	Radiated emission measurements
	<input type="checkbox"/> ANSI C63.10	11.12.2.7	Radiated spurious emission test
<input type="checkbox"/>	ANSI C63.10	6.4	Radiated emissions from unlicensed wireless devices below 30 MHz
<input type="checkbox"/>	ANSI C63.10	6.5	Radiated emissions from unlicensed wireless devices in the frequency range of 30 MHz to 1000 MHz
<input type="checkbox"/>	ANSI C63.10	6.6	Radiated emissions from unlicensed wireless devices above 1 GHz
	<input checked="" type="checkbox"/> ANSI C63.10	11.12.2	Antenna-port conducted measurements
	<input type="checkbox"/> ANSI C63.10	11.12.2.3	Quasi-peak measurement procedure
	<input checked="" type="checkbox"/> ANSI C63.10	11.12.2.4	Peak power measurement procedure
	<input type="checkbox"/> ANSI C63.10	11.12.2.5	Average power measurement procedures
	<input type="checkbox"/> ANSI C63.10	11.12.2.5.1	Trace averaging with continuous EUT transmission at full power
	<input type="checkbox"/> ANSI C63.10	11.12.2.5.2	Trace averaging across ON and OFF times of the EUT transmissions followed by duty cycle correction
	<input type="checkbox"/> ANSI C63.10	11.12.2.5.3	Reduced VBW averaging across ON and OFF times of the EUT transmissions with max hold

5.5. EUT test Axis definition

Item	Emissions in non-restricted frequency bands			
Device Category	<input type="checkbox"/>	Fixed point-to-point		
	<input type="checkbox"/>	Emit multiple directional beams, simultaneously or sequentially		
	<input checked="" type="checkbox"/>	Other cases		
Test mode	Mode 1			
Test method	<input type="checkbox"/>	Radiated		
		X Axis	Y Axis	Z Axis
				
		Worst Axis <input type="checkbox"/>	Worst Axis <input type="checkbox"/>	Worst Axis <input type="checkbox"/>
	<input checked="" type="checkbox"/>	Conducted		
	<input checked="" type="checkbox"/>	Chain 0		
				
	<input type="checkbox"/>	Chain 0	Chain 1	
				
	<input type="checkbox"/>	Chain 0	Chain 1	Chain 2
				

5.6. Test Result

Product Name	: LED lamp	Power	: AC 120V/60Hz
Test Mode	: Mode 1	Test Site	: TR-8
Test Date	: 2018.11.08	Test engineer	: Tommie

Mode	Channel	Test Frequency (MHz)	In-Band PSD[a] (dBm/100kHz)	Frequency (MHz)	Out-Band PSD[b] (dBm/100kHz)	[a]-[b] (dB)	Limit (dB)	Result
1	11	2405	5.039	2400.00	-45.207	50.066	>20	Pass
1	26	2480	4.394	2500.00	-45.025	49.419	>20	Pass

Note: The worst case of Emissions in non-restricted frequency bands as below:

Mode 1 CH26 (2480MHz)

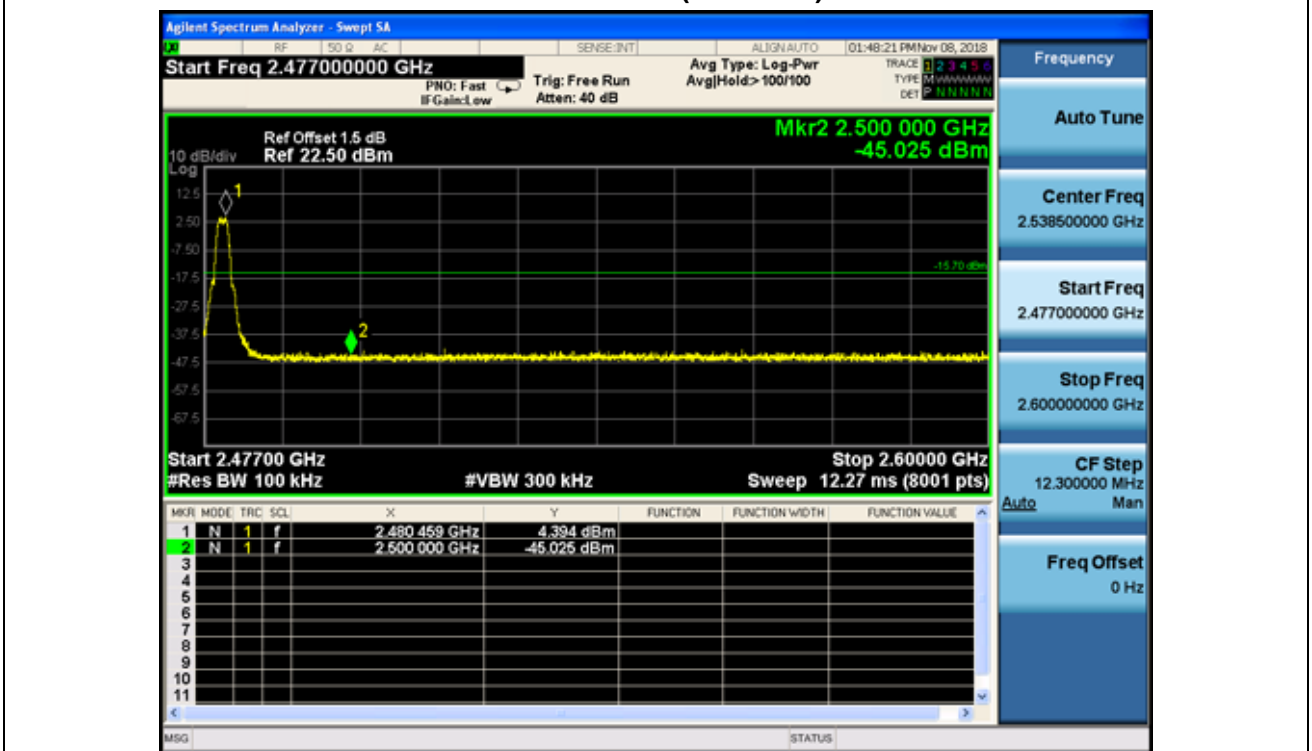

6. Radiated Emission Band Edge

6.1. Test Equipment

Radiated Emission(Above 1GHz) / AC-5					
Instrument	Manufacturer	Type No.	Serial No.	Cal. Date	Cal. Due Date
EMI Receiver	Agilent	N9038A	MY51210196	2018.07.16	2019.07.15
Pre-Amplifier	Miteq	NSP1800-25	1364185	2018.05.03	2019.05.02
DRG Horn Antenna	ETS-Lindgren	3117	00167055	2018.07.12	2019.07.11
Broad-Band Horn Antenna	Schwarzbeck	BBHA9170	294	2018.09.18	2019.09.17
Coaxial Cable	Huber+Suhner	SUCOFLEX 106	AC5-C1	2018.02.28	2019.02.27
Coaxial Cable	Huber+Suhner	SUCOFLEX 106	AC5-C2	2018.02.28	2019.02.27
Temperature/Humidity Meter	Zhichen	ZC1-2	AC5-TH	2018.01.05	2019.01.04

6.2. Test Setup

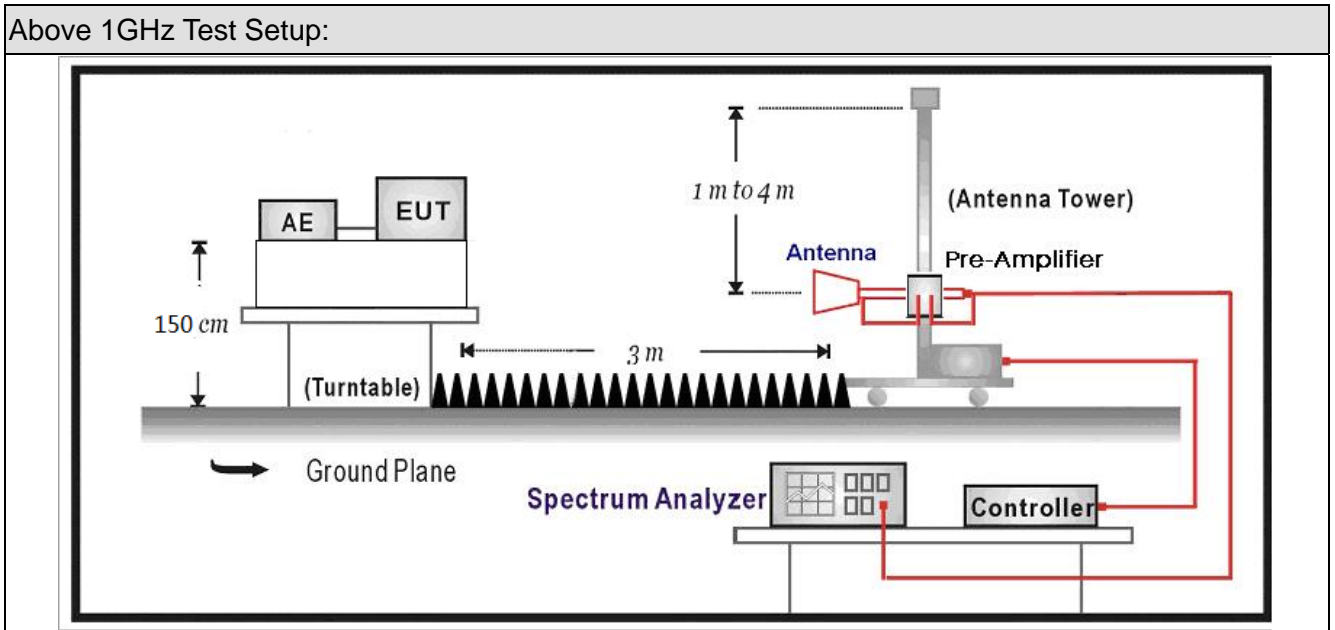

6.3. Limit





Band edge Limit				
Frequency bands (MHz)	Detector	Limit (dB μ V/m)	RBW (MHz)	Distance (m)
2310-2390	PK	74	1	3
2483.5-2500	AV	54	1	3

Note: The field strength of emissions appearing within these frequency bands shall not exceed the limits.

6.4. Test Procedure

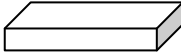
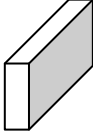
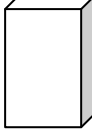
Test Method				
	References Rule		Chapter	Description
<input checked="" type="checkbox"/>	ANSI C63.10		6.10	Band-edge testing
	<input checked="" type="checkbox"/>	ANSI C63.10	6.10.5	Restricted-band band-edge measurements
	<input type="checkbox"/>	ANSI C63.10	6.10.6	Marker-delta method
<input checked="" type="checkbox"/>	ANSI C63.10		11.12	Emissions in restricted frequency bands
	<input checked="" type="checkbox"/>	ANSI C63.10	11.12.1	Radiated emission measurements
	<input checked="" type="checkbox"/>	ANSI C63.10	11.12.2.7	Radiated spurious emission test
<input type="checkbox"/>	ANSI C63.10		6.4	Radiated emissions from unlicensed wireless devices below 30 MHz
<input type="checkbox"/>	ANSI C63.10		6.5	Radiated emissions from unlicensed wireless devices in the frequency range of 30 MHz to 1000 MHz
<input checked="" type="checkbox"/>	ANSI C63.10		6.6	Radiated emissions from unlicensed wireless devices above 1 GHz
	<input type="checkbox"/>	ANSI C63.10	11.12.2.3	Quasi-peak measurement procedure
	<input checked="" type="checkbox"/>	ANSI C63.10	11.12.2.4	Peak power measurement procedure
	<input checked="" type="checkbox"/>	ANSI C63.10	11.12.2.5	Average power measurement procedures
	<input type="checkbox"/>	ANSI C63.10	11.12.2.5.1	Trace averaging with continuous EUT transmission at full power
	<input type="checkbox"/>	ANSI C63.10	11.12.2.5.2	Trace averaging across ON and OFF times of the EUT transmissions followed by duty cycle correction
	<input checked="" type="checkbox"/>	ANSI C63.10	11.12.2.5.3	Reduced VBW averaging across ON and OFF times of the EUT transmissions with max hold

6.5. EUT test definition

Item	Radiated Emission Band Edge			
Device Category	<input type="checkbox"/>	Fixed point-to-point		
	<input type="checkbox"/>	Emit multiple directional beams, simultaneously or sequentially		
	<input checked="" type="checkbox"/>	Other cases		
Test mode	Mode 1			
Test method	<input checked="" type="checkbox"/>	Radiated		
		X Axis	Y Axis	Z Axis
				
		Worst Axis <input checked="" type="checkbox"/>	Worst Axis <input type="checkbox"/>	Worst Axis <input type="checkbox"/>
	<input type="checkbox"/>	Conducted		
	<input type="checkbox"/>	Chain 0		
				
	<input type="checkbox"/>	Chain 0	Chain 1	
				
	<input type="checkbox"/>	Chain 0	Chain 1	Chain 2
				

6.6. Duty Cycle

Test Mode	Tx On (ms)	Tx Off (ms)	Reduced VBW (kHz)	Tx On + Tx Off (ms)	Duty Cycle
Zigbee	-	-	10Hz	-	100%

Zigbee

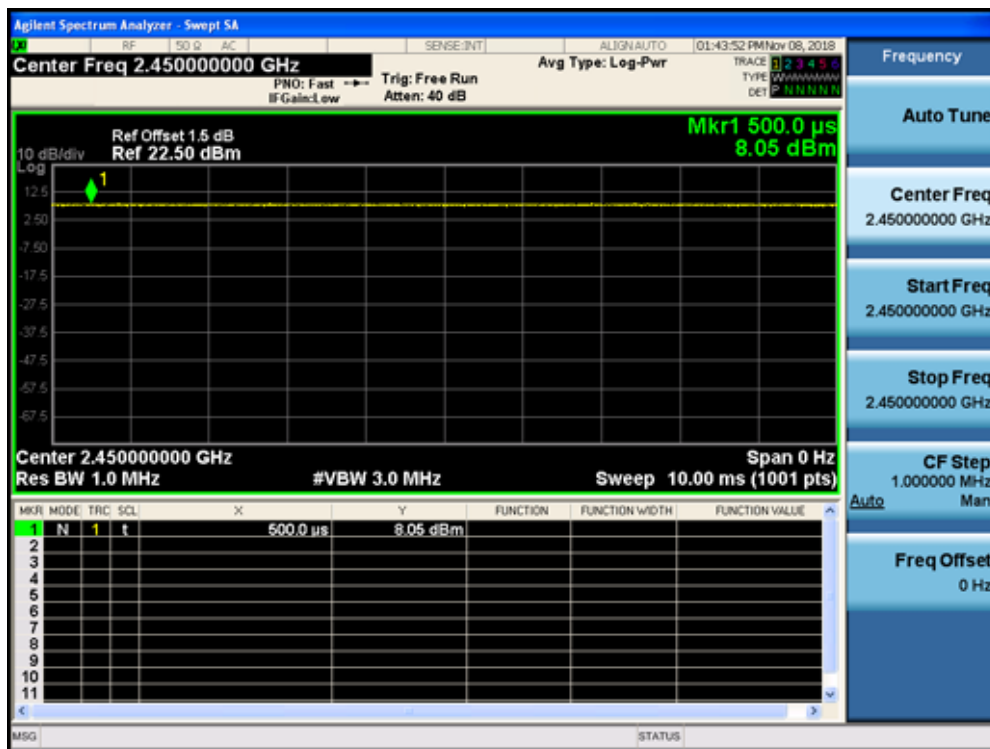

6.7 Test Result

LED lamp (Crystal oscillator: Diode (FL3840023)_2017; Lighting source: LTN)

Engineer: Karl	
Site: AC5	Time: 2018/11/07 - 21:11
Limit: FCC_Part15.209_RE(3m)	Margin: 0
Probe: Horn_3117_00167055(1-18GHz)	Polarity: Horizontal
EUT: LED lamp	Power: AC 120V/60Hz
Note: Mode 1:Transmit at 2405MHz by Zigbee LTN	

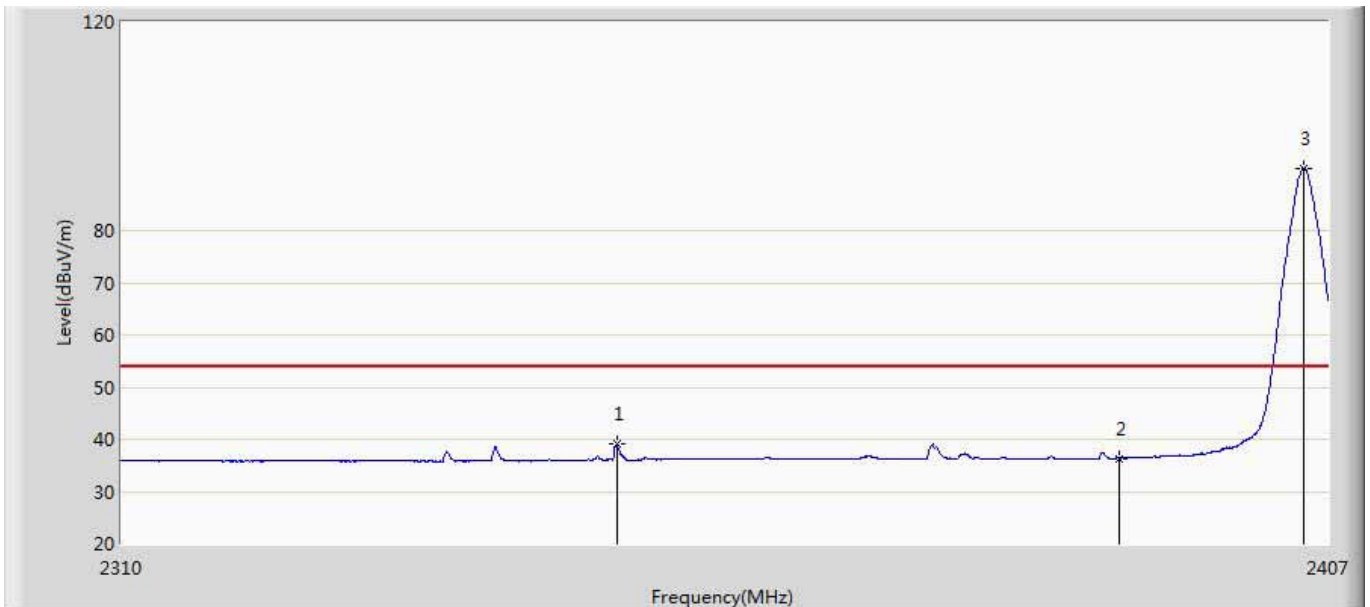

No	Mark	Frequency (MHz)	Measure Level (dBuV/m)	Reading Level (dBuV)	Over Limit (dB)	Limit (dBuV/m)	Factor (dB)	Type
1		2349.382	39.243	2.985	-14.757	54.000	36.259	AV
2		2390.000	36.361	-0.063	-17.639	54.000	36.424	AV
3	*	2405.060	91.896	55.509	37.896	54.000	36.387	AV

Engineer: Karl	
Site: AC5	Time: 2018/11/07 - 21:27
Limit: FCC_Part15.209_RE(3m)	Margin: 0
Probe: Horn_3117_00167055(1-18GHz)	Polarity: Horizontal
EUT: LED lamp	Power: AC 120V/60Hz
Note: Mode 1:Transmit at 2405MHz by Zigbee LTN	

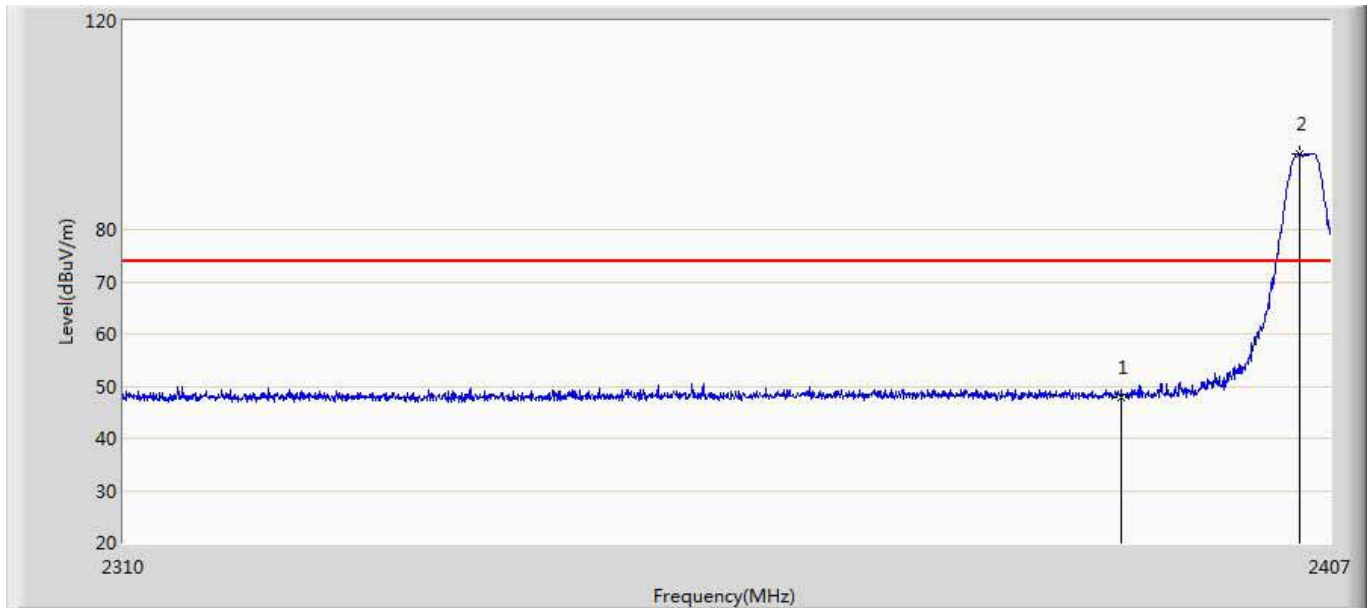

No	Mark	Frequency (MHz)	Measure Level (dBuV/m)	Reading Level (dBuV)	Over Limit (dB)	Limit (dBuV/m)	Factor (dB)	Type
1		2390.000	47.850	11.426	-26.150	74.000	36.424	PK
2	*	2404.478	94.617	58.228	20.617	74.000	36.388	PK

Engineer: Karl	
Site: AC5	Time: 2018/11/07 - 21:28
Limit: FCC_Part15.209_RE(3m)	Margin: 0
Probe: Horn_3117_00167055(1-18GHz)	Polarity: Vertical
EUT: LED lamp	Power: AC 120V/60Hz
Note: Mode 1:Transmit at 2405MHz by Zigbee LTN	

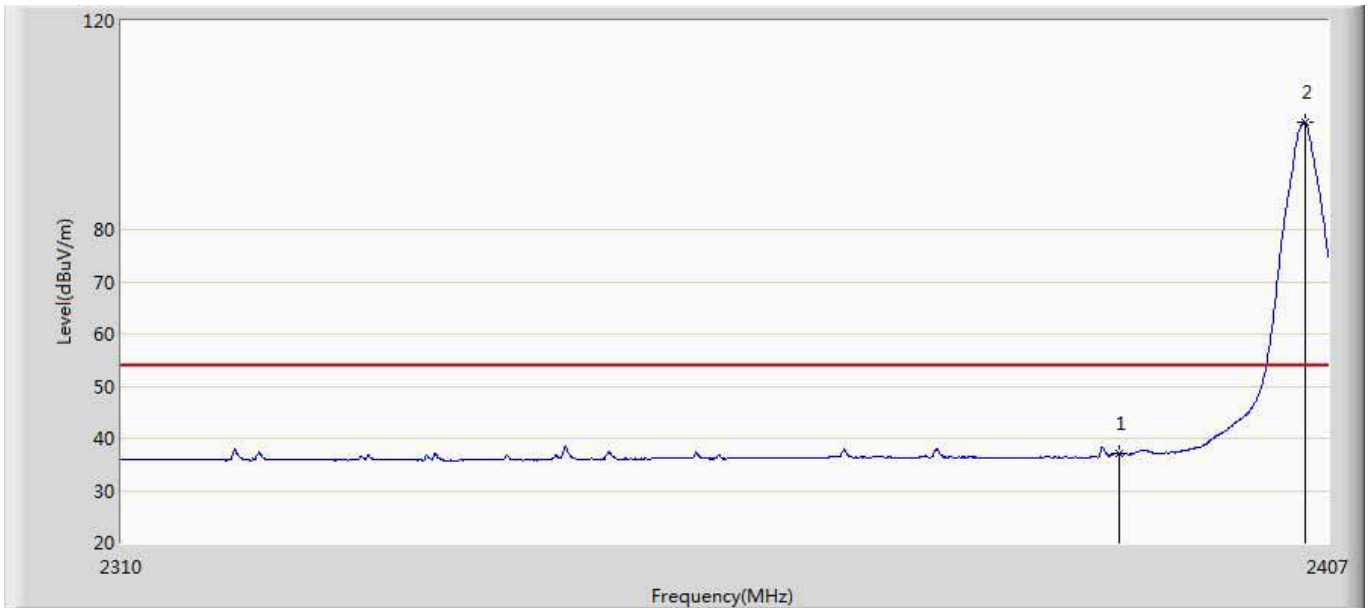

No	Mark	Frequency (MHz)	Measure Level (dBuV/m)	Reading Level (dBuV)	Over Limit (dB)	Limit (dBuV/m)	Factor (dB)	Type
1		2390.000	37.027	0.603	-16.973	54.000	36.424	AV
2	*	2405.108	100.598	64.211	46.598	54.000	36.387	AV

Engineer: Karl	
Site: AC5	Time: 2018/11/07 - 21:30
Limit: FCC_Part15.209_RE(3m)	Margin: 0
Probe: Horn_3117_00167055(1-18GHz)	Polarity: Vertical
EUT: LED lamp	Power: AC 120V/60Hz
Note: Mode 1:Transmit at 2405MHz by Zigbee LTN	

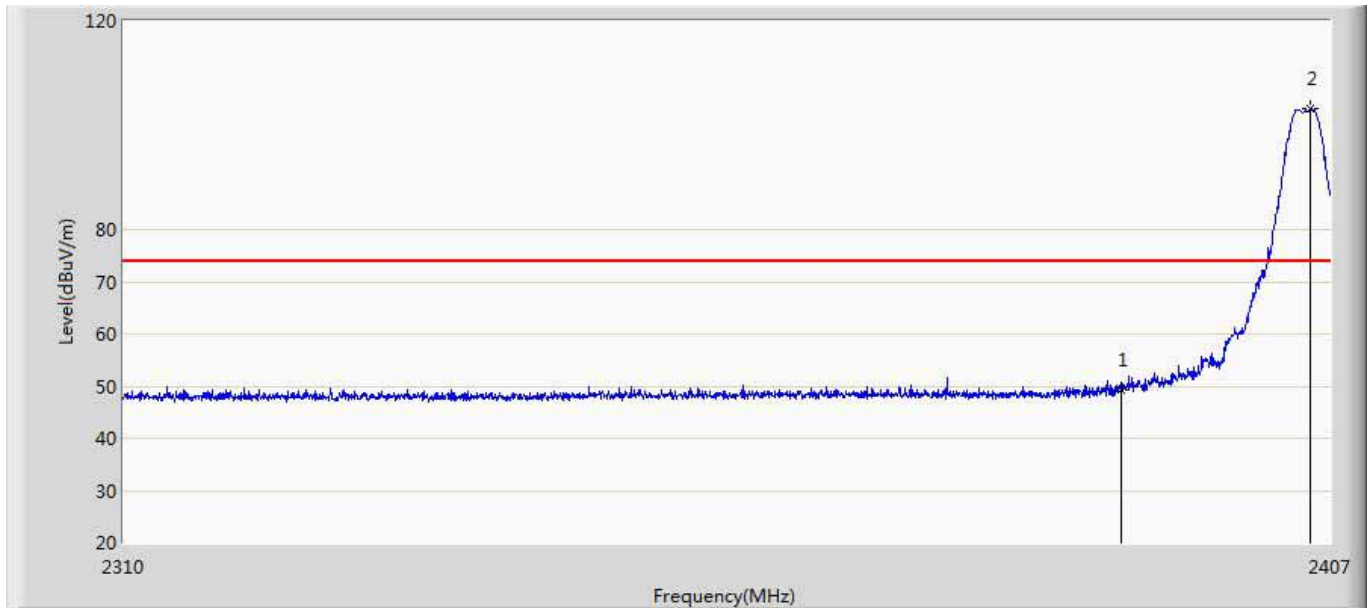

No	Mark	Frequency (MHz)	Measure Level (dBuV/m)	Reading Level (dBuV)	Over Limit (dB)	Limit (dBuV/m)	Factor (dB)	Type
1		2390.000	49.311	12.887	-24.689	74.000	36.424	PK
2	*	2405.399	103.089	66.702	29.089	74.000	36.386	PK

Engineer: Karl	
Site: AC5	Time: 2018/11/07 - 21:33
Limit: FCC_Part15.209_RE(3m)	Margin: 0
Probe: Horn_3117_00167055(1-18GHz)	Polarity: Horizontal
EUT: LED lamp	Power: AC 120V/60Hz
Note: Mode 1:Transmit at 2480MHz by Zigbee LTN	

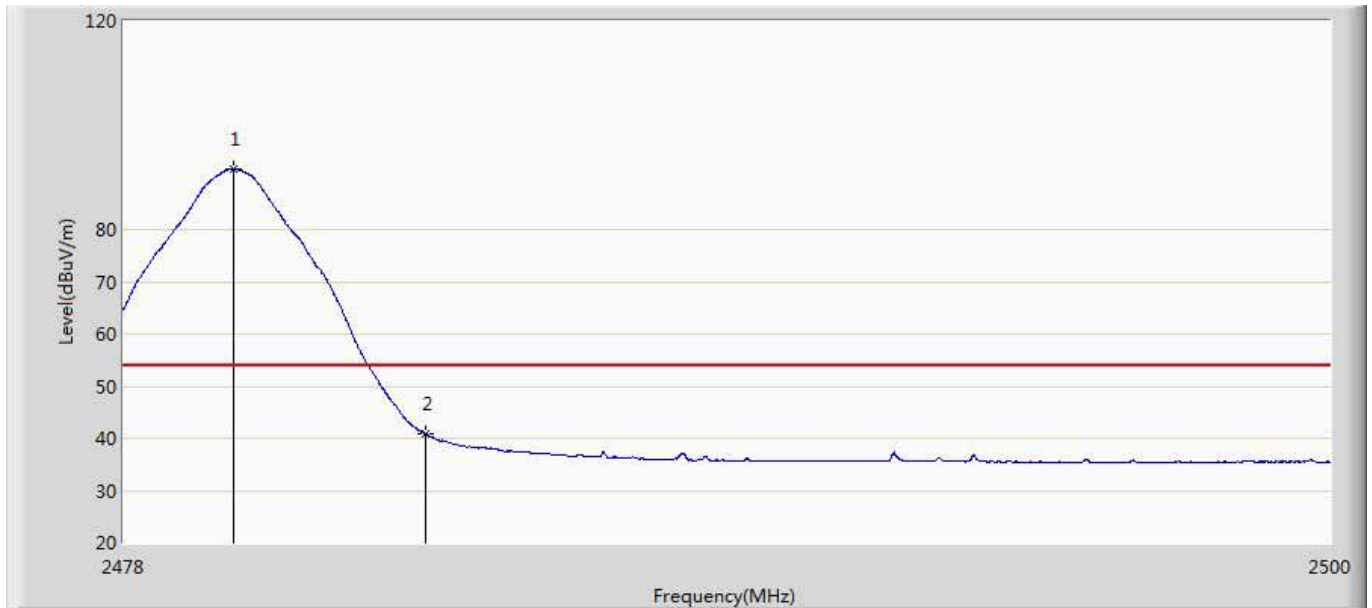

No	Mark	Frequency (MHz)	Measure Level (dBuV/m)	Reading Level (dBuV)	Over Limit (dB)	Limit (dBuV/m)	Factor (dB)	Type
1	*	2480.013	91.599	54.959	37.599	54.000	36.640	AV
2		2483.500	40.838	4.192	-13.162	54.000	36.646	AV

Engineer: Karl	
Site: AC5	Time: 2018/11/07 - 21:38
Limit: FCC_Part15.209_RE(3m)	Margin: 0
Probe: Horn_3117_00167055(1-18GHz)	Polarity: Horizontal
EUT: LED lamp	Power: AC 120V/60Hz
Note: Mode 1:Transmit at 2480MHz by Zigbee LTN	

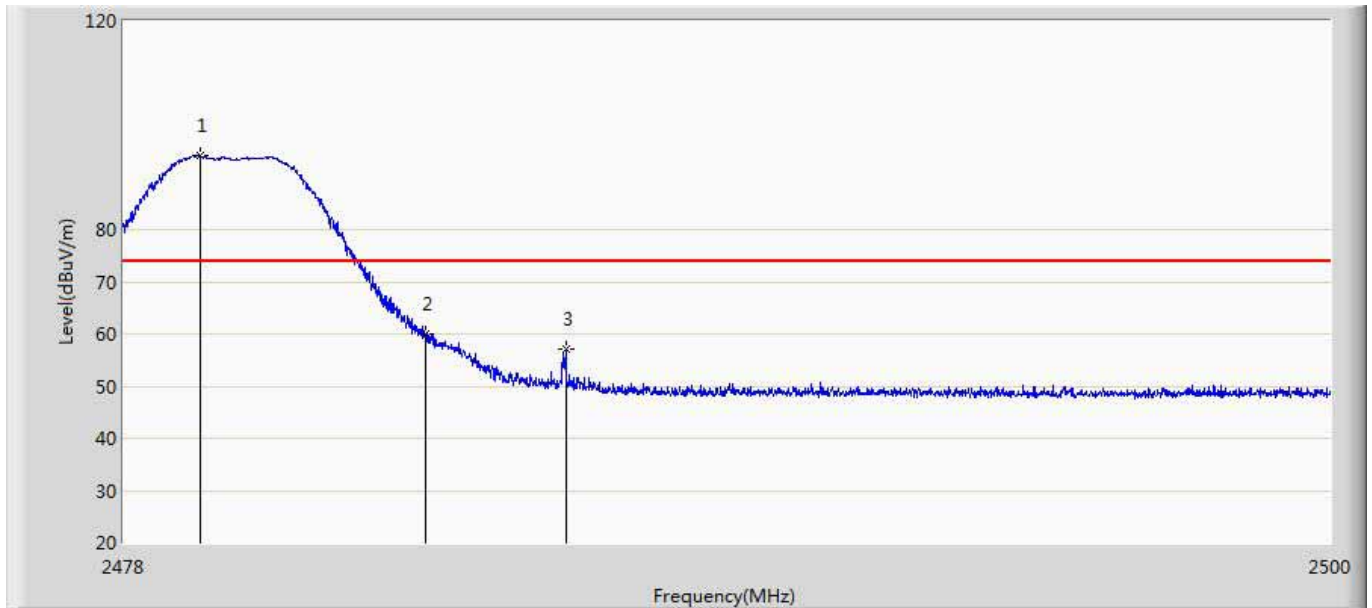

No	Mark	Frequency (MHz)	Measure Level (dBuV/m)	Reading Level (dBuV)	Over Limit (dB)	Limit (dBuV/m)	Factor (dB)	Type
1	*	2479.397	94.254	57.615	20.254	74.000	36.638	PK
2		2483.500	59.960	23.314	-14.040	74.000	36.646	PK
3		2486.052	57.199	20.548	-16.801	74.000	36.651	PK

Engineer: Karl	
Site: AC5	Time: 2018/11/07 - 21:40
Limit: FCC_Part15.209_RE(3m)	Margin: 0
Probe: Horn_3117_00167055(1-18GHz)	Polarity: Vertical
EUT: LED lamp	Power: AC 120V/60Hz
Note: Mode 1:Transmit at 2480MHz by Zigbee LTN	

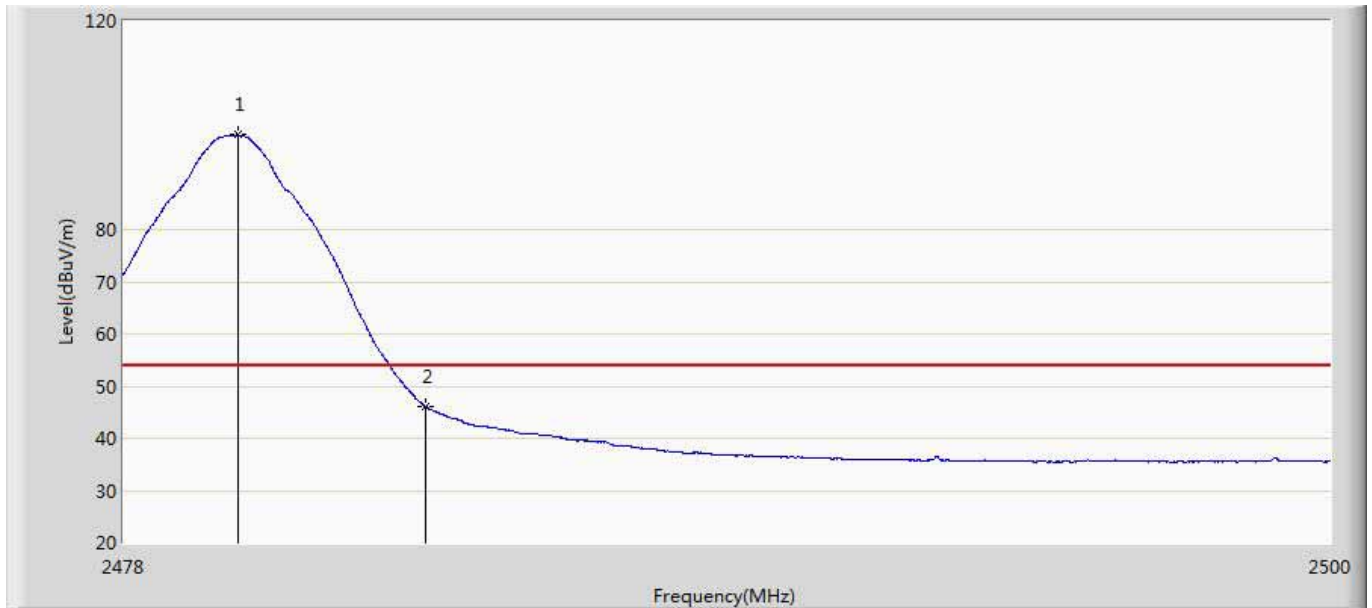

No	Mark	Frequency (MHz)	Measure Level (dBuV/m)	Reading Level (dBuV)	Over Limit (dB)	Limit (dBuV/m)	Factor (dB)	Type
1	*	2480.079	98.121	61.481	44.121	54.000	36.640	AV
2		2483.500	46.014	9.368	-7.986	54.000	36.646	AV

Engineer: Karl	
Site: AC5	Time: 2018/11/07 - 21:46
Limit: FCC_Part15.209_RE(3m)	Margin: 0
Probe: Horn_3117_00167055(1-18GHz)	Polarity: Vertical
EUT: LED lamp	Power: AC 120V/60Hz
Note: Mode 1:Transmit at 2480MHz by Zigbee LTN	

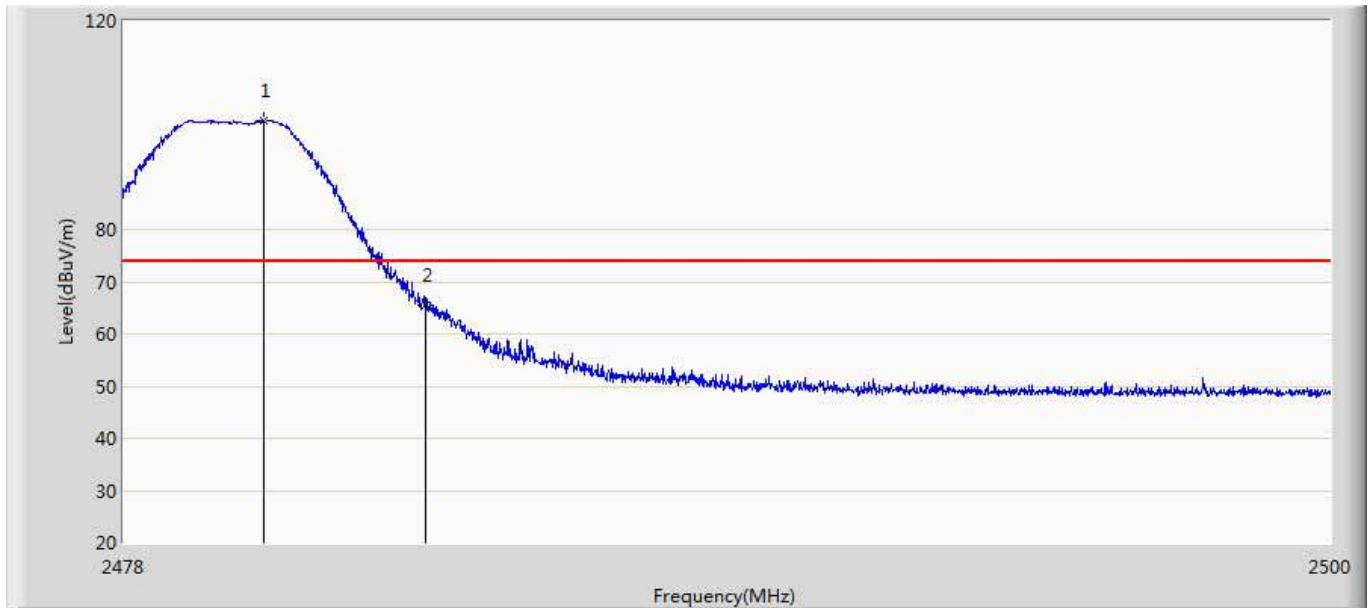

No	Mark	Frequency (MHz)	Measure Level (dBuV/m)	Reading Level (dBuV)	Over Limit (dB)	Limit (dBuV/m)	Factor (dB)	Type
1	*	2480.563	101.012	64.371	27.012	74.000	36.641	PK
2		2483.500	65.614	28.968	-8.386	74.000	36.646	PK

LED lamp (Crystal oscillator: Diode (FL3840023)_2017; Lighting source: APT)

Engineer: Karl	
Site: AC5	Time: 2018/11/07 - 21:46
Limit: FCC_Part15.209_RE(3m)	Margin: 0
Probe: Horn_3117_00167055(1-18GHz)	Polarity: Horizontal
EUT: LED lamp	Power: AC 120V/60Hz
Note: Mode 1:Transmit at 2405MHz by Zigbee APT	

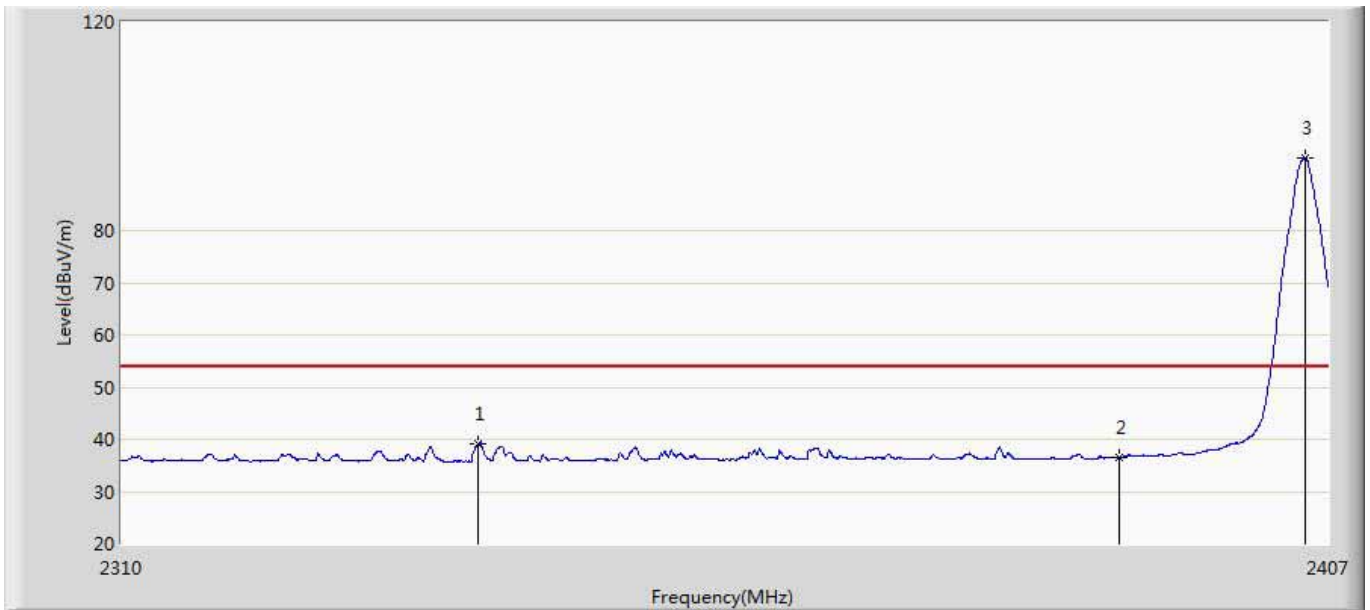

No	Mark	Frequency (MHz)	Measure Level (dBuV/m)	Reading Level (dBuV)	Over Limit (dB)	Limit (dBuV/m)	Factor (dB)	Type
1		2338.227	39.144	2.992	-14.856	54.000	36.152	AV
2		2390.000	36.488	0.064	-17.512	54.000	36.424	AV
3	*	2405.108	94.018	57.631	40.018	54.000	36.387	AV

Engineer: Karl	
Site: AC5	Time: 2018/11/07 - 21:50
Limit: FCC_Part15.209_RE(3m)	Margin: 0
Probe: Horn_3117_00167055(1-18GHz)	Polarity: Horizontal
EUT: LED lamp	Power: AC 120V/60Hz
Note: Mode 1:Transmit at 2405MHz by Zigbee APT	

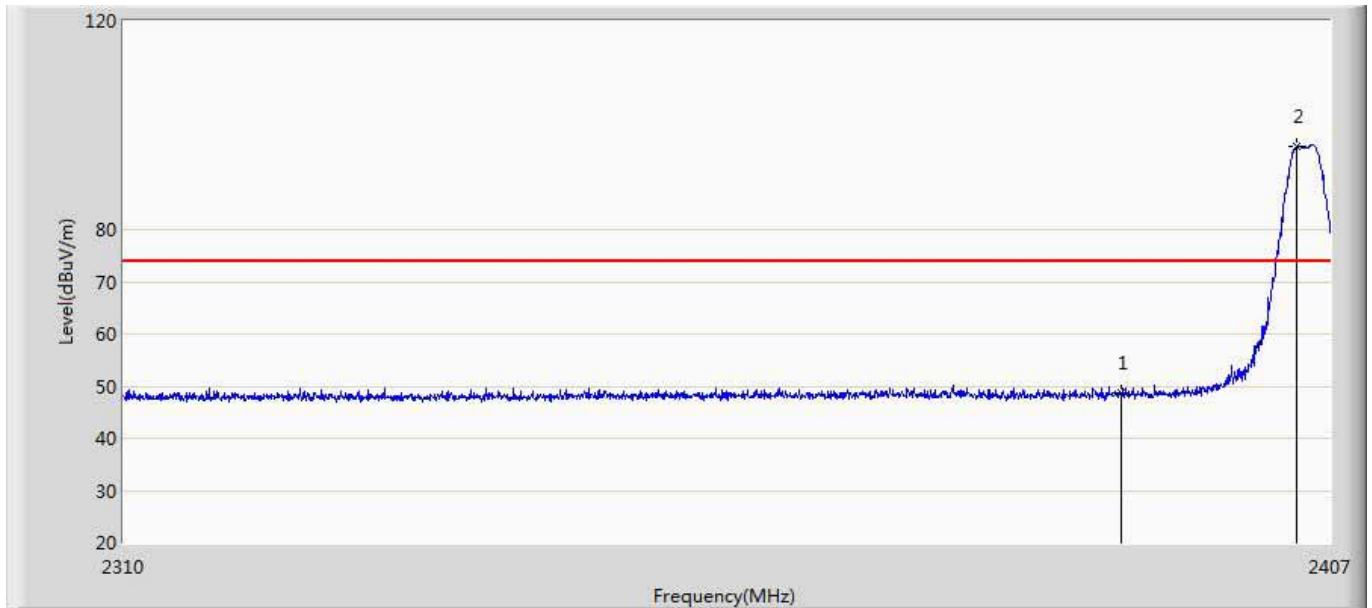

No	Mark	Frequency (MHz)	Measure Level (dBuV/m)	Reading Level (dBuV)	Over Limit (dB)	Limit (dBuV/m)	Factor (dB)	Type
1		2390.000	48.585	12.161	-25.415	74.000	36.424	PK
2	*	2404.284	95.982	59.593	21.982	74.000	36.389	PK

Engineer: Karl	
Site: AC5	Time: 2018/11/07 - 21:52
Limit: FCC_Part15.209_RE(3m)	Margin: 0
Probe: Horn_3117_00167055(1-18GHz)	Polarity: Vertical
EUT: LED lamp	Power: AC 120V/60Hz
Note: Mode 1:Transmit at 2405MHz by Zigbee APT	

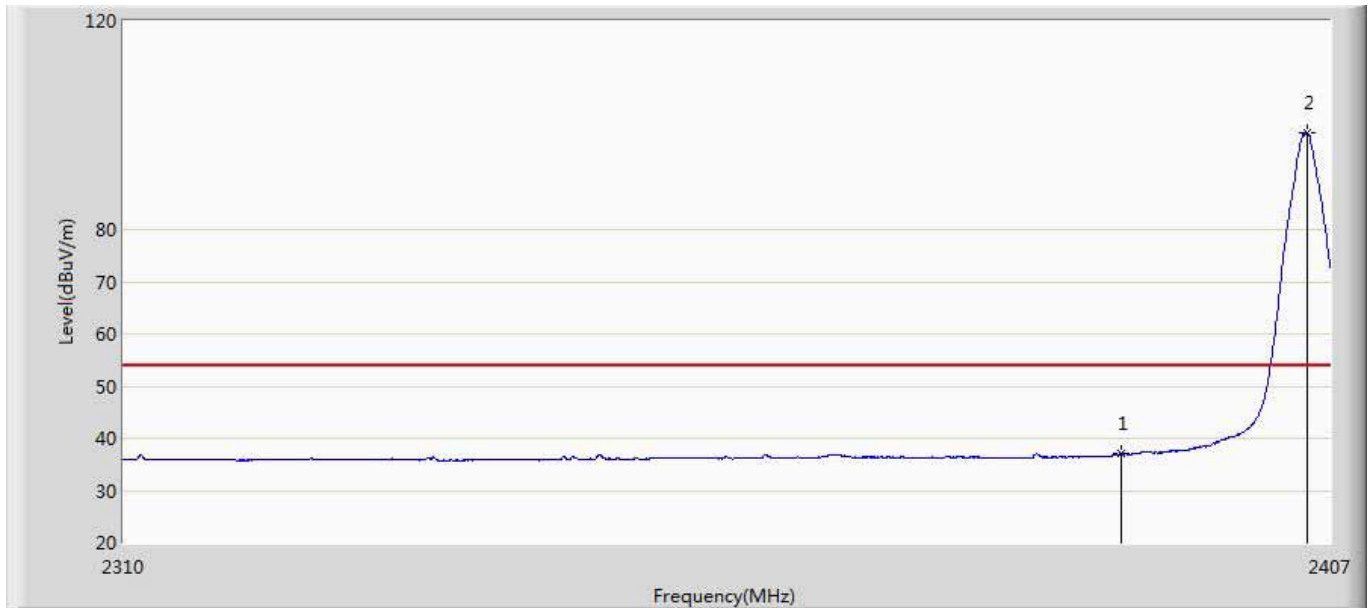

No	Mark	Frequency (MHz)	Measure Level (dBuV/m)	Reading Level (dBuV)	Over Limit (dB)	Limit (dBuV/m)	Factor (dB)	Type
1		2390.000	36.978	0.554	-17.022	54.000	36.424	AV
2	*	2405.108	98.615	62.228	44.615	54.000	36.387	AV

Engineer: Karl	
Site: AC5	Time: 2018/11/07 - 21:54
Limit: FCC_Part15.209_RE(3m)	Margin: 0
Probe: Horn_3117_00167055(1-18GHz)	Polarity: Vertical
EUT: LED lamp	Power: AC 120V/60Hz
Note: Mode 1:Transmit at 2405MHz by Zigbee APT	

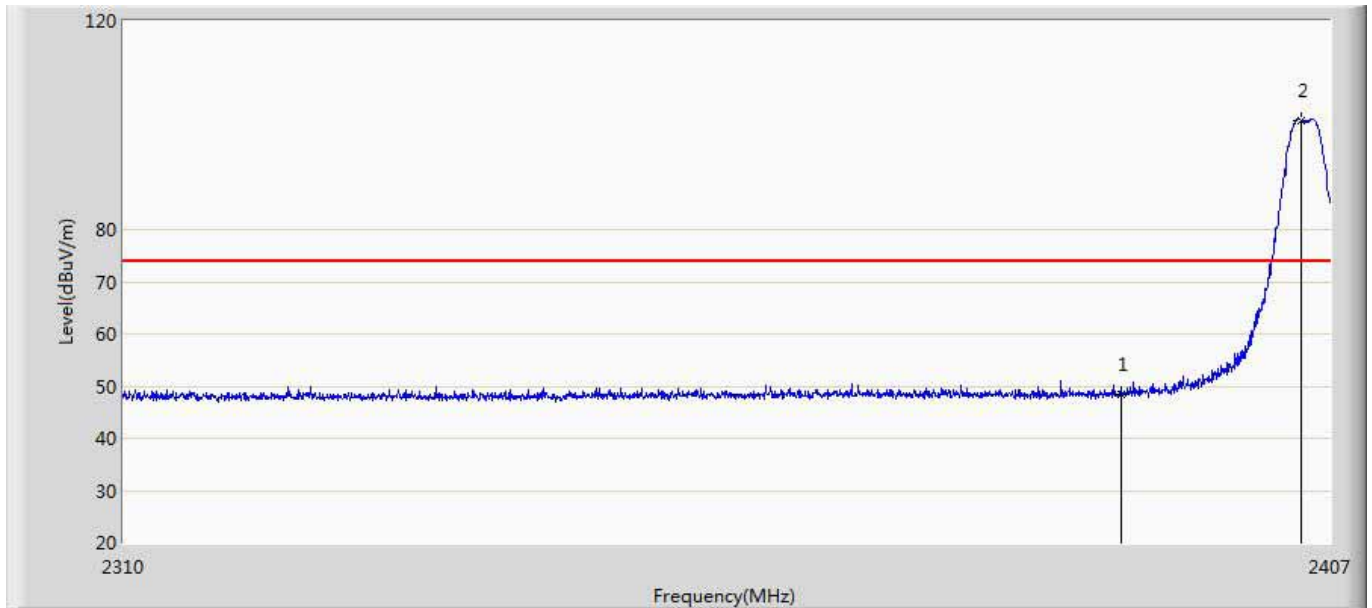

No	Mark	Frequency (MHz)	Measure Level (dBuV/m)	Reading Level (dBuV)	Over Limit (dB)	Limit (dBuV/m)	Factor (dB)	Type
1		2390.000	48.510	12.086	-25.490	74.000	36.424	PK
2	*	2404.624	101.013	64.625	27.013	74.000	36.388	PK

Engineer: Karl	
Site: AC5	Time: 2018/11/07 - 21:56
Limit: FCC_Part15.209_RE(3m)	Margin: 0
Probe: Horn_3117_00167055(1-18GHz)	Polarity: Horizontal
EUT: LED lamp	Power: AC 120V/60Hz
Note: Mode 1:Transmit at 2480MHz by Zigbee APT	

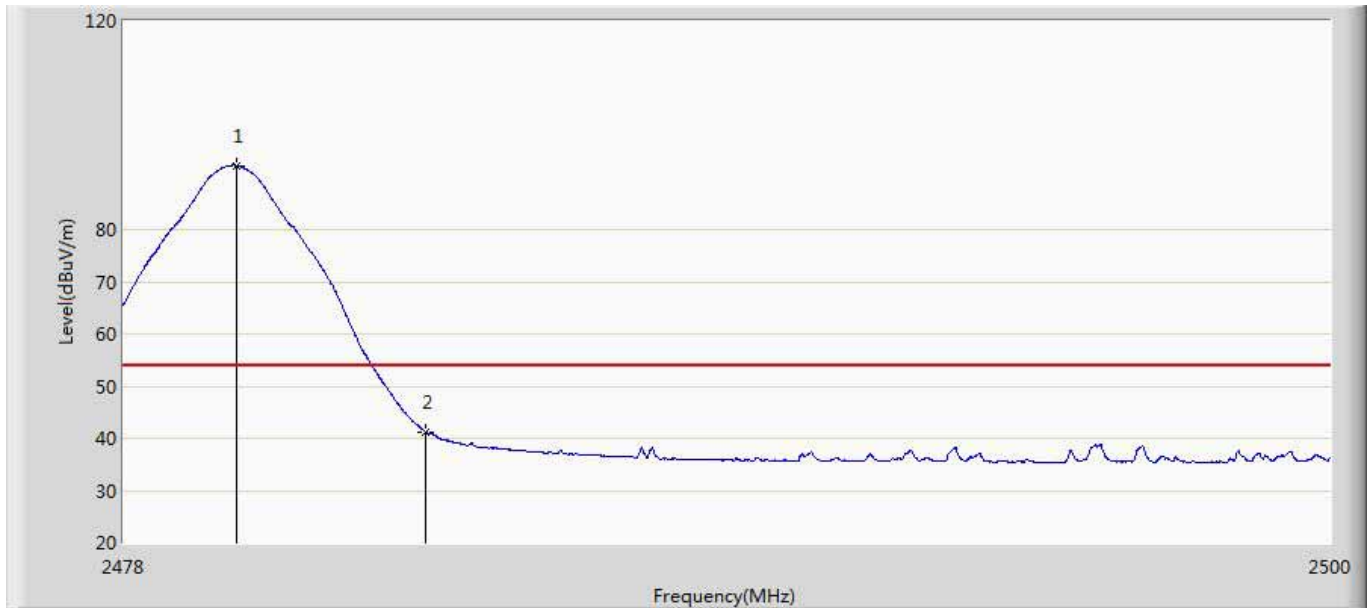

No	Mark	Frequency (MHz)	Measure Level (dBuV/m)	Reading Level (dBuV)	Over Limit (dB)	Limit (dBuV/m)	Factor (dB)	Type
1	*	2480.046	92.256	55.616	38.256	54.000	36.640	AV
2		2483.500	41.248	4.602	-12.752	54.000	36.646	AV

Engineer: Karl	
Site: AC5	Time: 2018/11/07 - 21:59
Limit: FCC_Part15.209_RE(3m)	Margin: 0
Probe: Horn_3117_00167055(1-18GHz)	Polarity: Horizontal
EUT: LED lamp	Power: AC 120V/60Hz
Note: Mode 1:Transmit at 2480MHz by Zigbee APT	

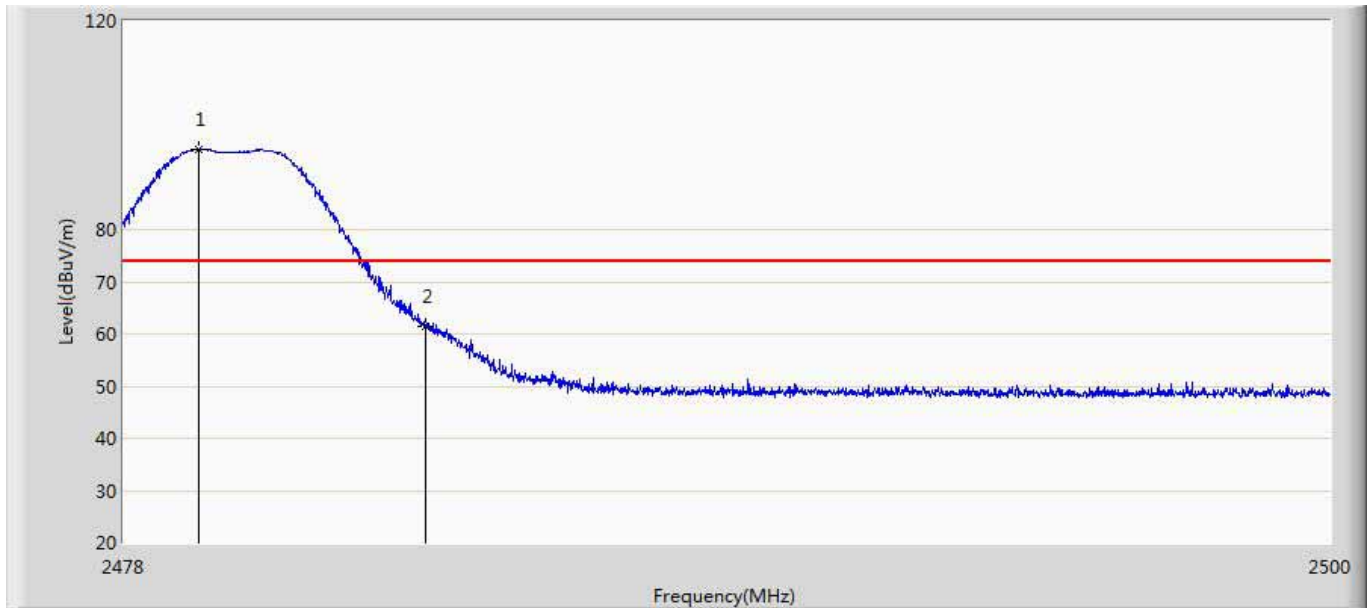

No	Mark	Frequency (MHz)	Measure Level (dBuV/m)	Reading Level (dBuV)	Over Limit (dB)	Limit (dBuV/m)	Factor (dB)	Type
1	*	2479.364	95.338	58.699	21.338	74.000	36.638	PK
2		2483.500	61.376	24.730	-12.624	74.000	36.646	PK

Engineer: Karl	
Site: AC5	Time: 2018/11/07 - 22:01
Limit: FCC_Part15.209_RE(3m)	Margin: 0
Probe: Horn_3117_00167055(1-18GHz)	Polarity: Vertical
EUT: LED lamp	Power: AC 120V/60Hz
Note: Mode 1:Transmit at 2480MHz by Zigbee APT	

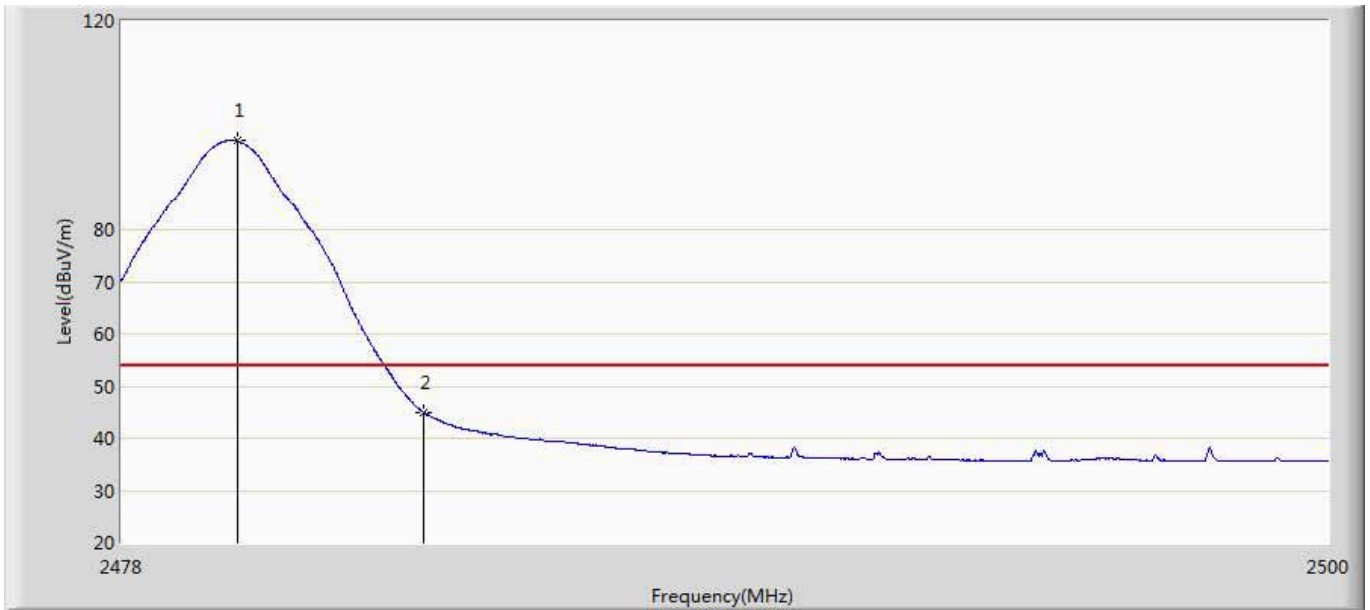

No	Mark	Frequency (MHz)	Measure Level (dBuV/m)	Reading Level (dBuV)	Over Limit (dB)	Limit (dBuV/m)	Factor (dB)	Type
1	*	2480.112	96.978	60.338	42.978	54.000	36.640	AV
2		2483.500	45.009	8.363	-8.991	54.000	36.646	AV

Engineer: Karl	
Site: AC5	Time: 2018/11/07 - 22:03
Limit: FCC_Part15.209_RE(3m)	Margin: 0
Probe: Horn_3117_00167055(1-18GHz)	Polarity: Vertical
EUT: LED lamp	Power: AC 120V/60Hz
Note: Mode 1:Transmit at 2480MHz by Zigbee APT	

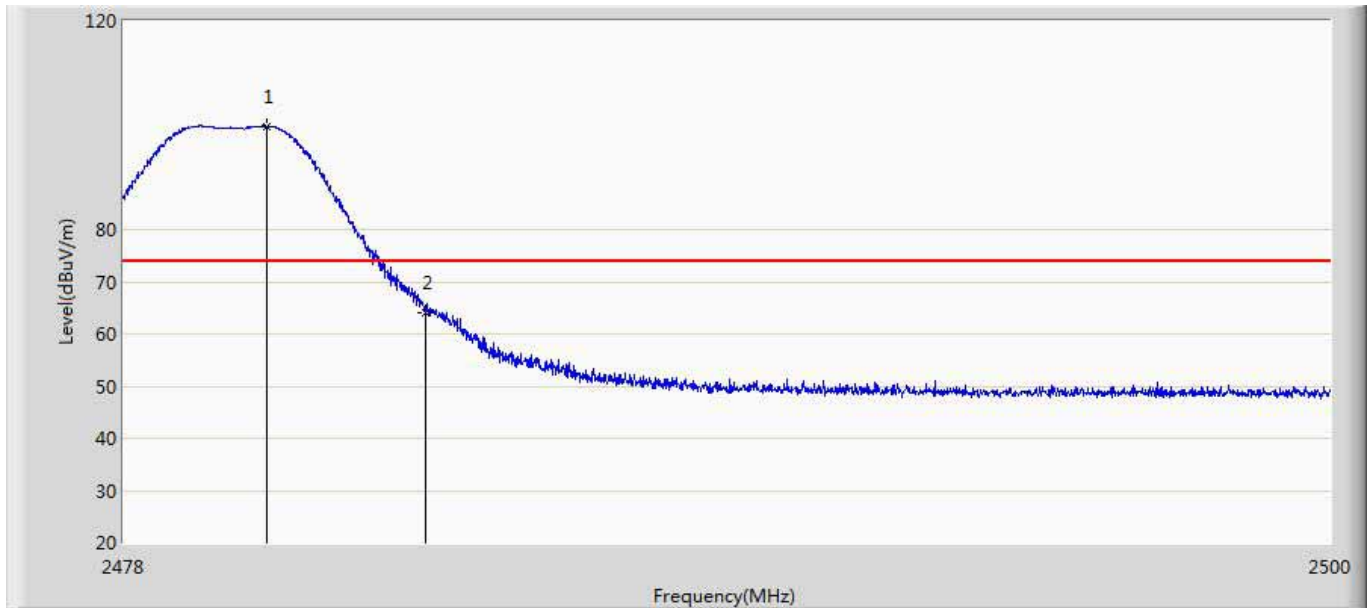

No	Mark	Frequency (MHz)	Measure Level (dBuV/m)	Reading Level (dBuV)	Over Limit (dB)	Limit (dBuV/m)	Factor (dB)	Type
1	*	2480.596	99.777	63.136	25.777	74.000	36.641	PK
2		2483.500	64.111	27.465	-9.889	74.000	36.646	PK

LED lamp (Crystal oscillator: Murata(XRCGB38M400FXH17R0))

Engineer: Karl	
Site: AC5	Time: 2018/11/09 - 21:01
Limit: FCC_Part15.209_RE(3m)	Margin: 0
Probe: Horn_3117_00167055(1-18GHz)	Polarity: Horizontal
EUT: LED lamp	Power: AC 120V/60Hz
Note: Mode 1:Transmit at 2405MHz by Zigbee	

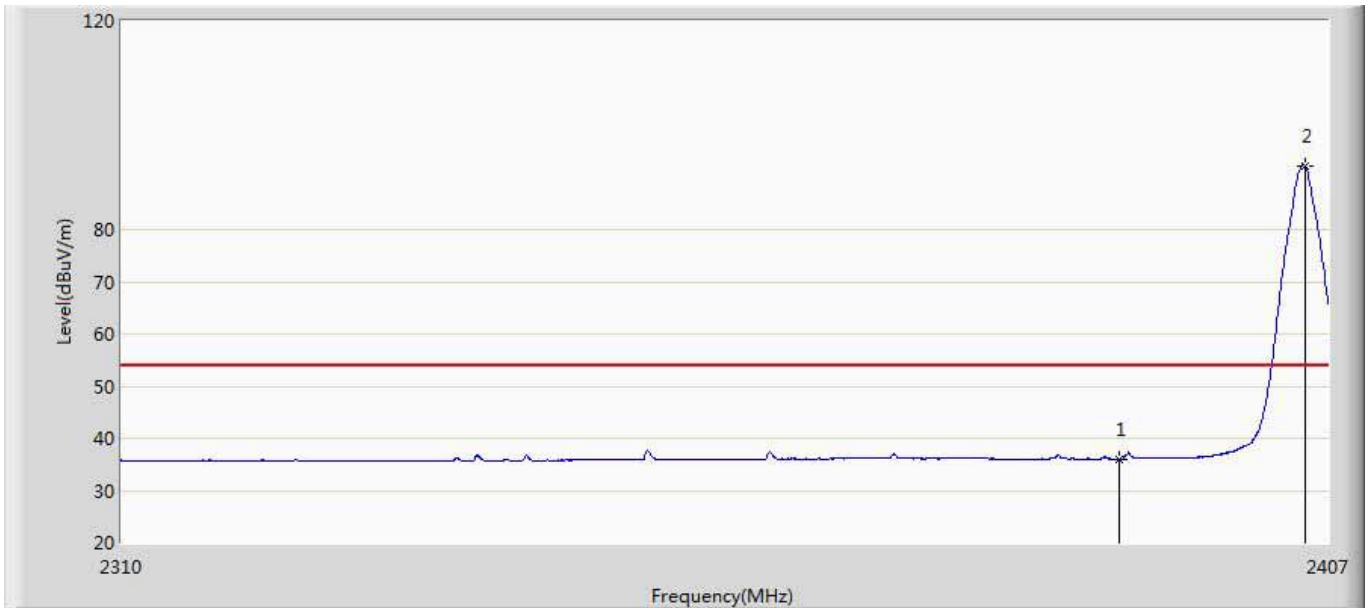

No	Mark	Frequency (MHz)	Measure Level (dBuV/m)	Reading Level (dBuV)	Over Limit (dB)	Limit (dBuV/m)	Factor (dB)	Type
1		2390.000	36.027	-0.397	-17.973	54.000	36.424	AV
2	*	2405.108	92.315	55.928	38.315	54.000	36.387	AV

Engineer: Karl	
Site: AC5	Time: 2018/11/09 - 21:05
Limit: FCC_Part15.209_RE(3m)	Margin: 0
Probe: Horn_3117_00167055(1-18GHz)	Polarity: Horizontal
EUT: LED lamp	Power: AC 120V/60Hz
Note: Mode 1:Transmit at 2405MHz by Zigbee	

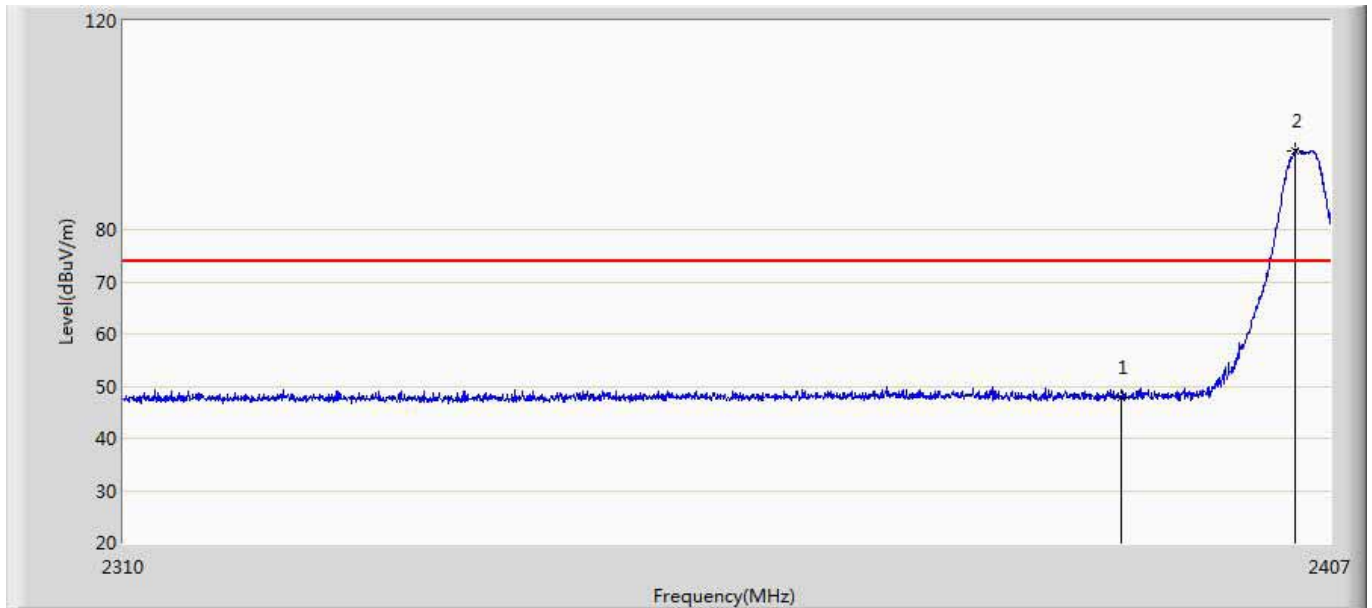

No	Mark	Frequency (MHz)	Measure Level (dBuV/m)	Reading Level (dBuV)	Over Limit (dB)	Limit (dBuV/m)	Factor (dB)	Type
1		2390.000	47.764	11.340	-26.236	74.000	36.424	PK
2	*	2404.138	95.077	58.688	21.077	74.000	36.389	PK

Engineer: Karl	
Site: AC5	Time: 2018/11/09 - 21:07
Limit: FCC_Part15.209_RE(3m)	Margin: 0
Probe: Horn_3117_00167055(1-18GHz)	Polarity: Vertical
EUT: LED lamp	Power: AC 120V/60Hz
Note: Mode 1:Transmit at 2405MHz by Zigbee	

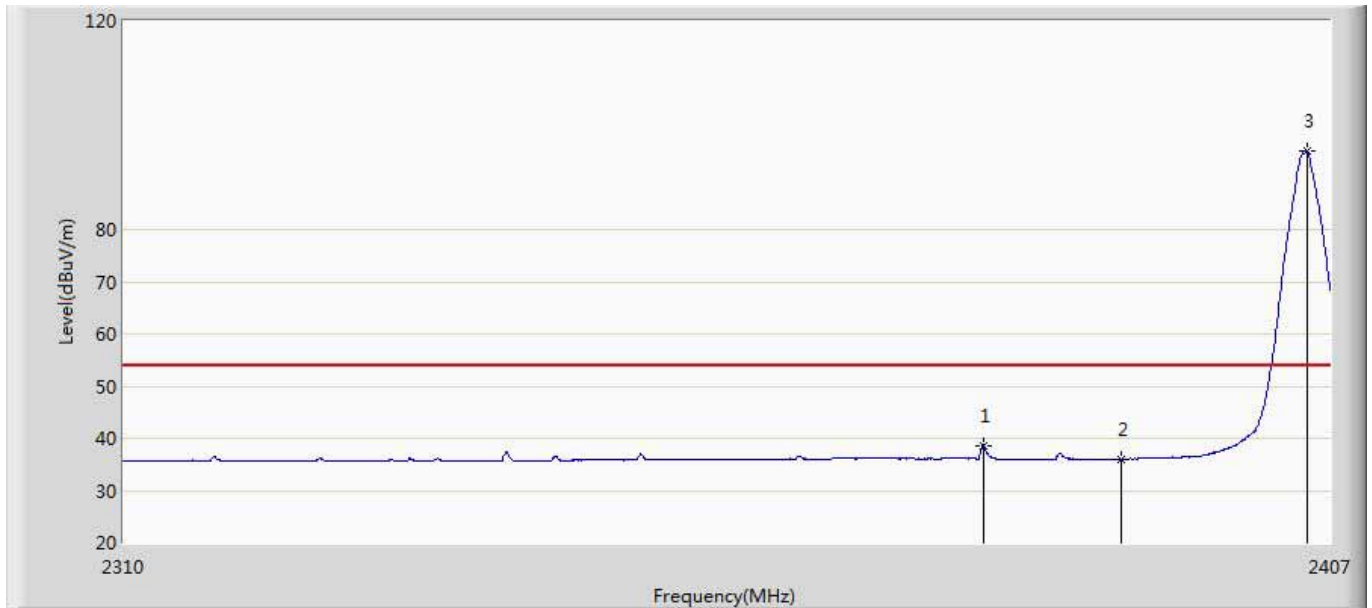

No	Mark	Frequency (MHz)	Measure Level (dBuV/m)	Reading Level (dBuV)	Over Limit (dB)	Limit (dBuV/m)	Factor (dB)	Type
1		2378.773	38.638	2.181	-15.362	54.000	36.457	AV
2		2390.000	36.035	-0.389	-17.965	54.000	36.424	AV
3	*	2405.108	95.017	58.630	41.017	54.000	36.387	AV

Engineer: Karl	
Site: AC5	Time: 2018/11/09 - 21:09
Limit: FCC_Part15.209_RE(3m)	Margin: 0
Probe: Horn_3117_00167055(1-18GHz)	Polarity: Vertical
EUT: LED lamp	Power: AC 120V/60Hz
Note: Mode 1:Transmit at 2405MHz by Zigbee	

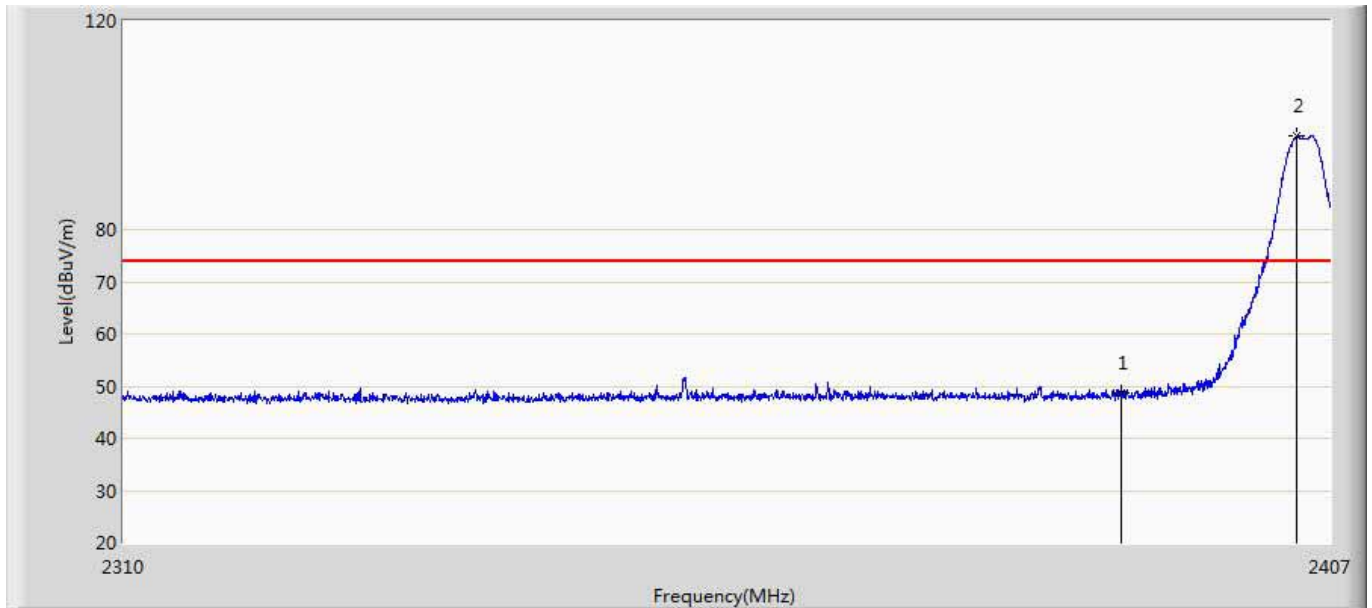

No	Mark	Frequency (MHz)	Measure Level (dBuV/m)	Reading Level (dBuV)	Over Limit (dB)	Limit (dBuV/m)	Factor (dB)	Type
1		2390.000	48.795	12.371	-25.205	74.000	36.424	PK
2	*	2404.333	97.914	61.525	23.914	74.000	36.389	PK

Profile: 18B2025R	Page No.: 69
Engineer: Karl	
Site: AC5	Time: 2018/11/09 - 21:11
Limit: FCC_Part15.209_RE(3m)	Margin: 0
Probe: Horn_3117_00167055(1-18GHz)	Polarity: Horizontal
EUT: LED lamp	Power: AC 120V/60Hz
Note: Mode 1:Transmit at 2480MHz by Zigbee	

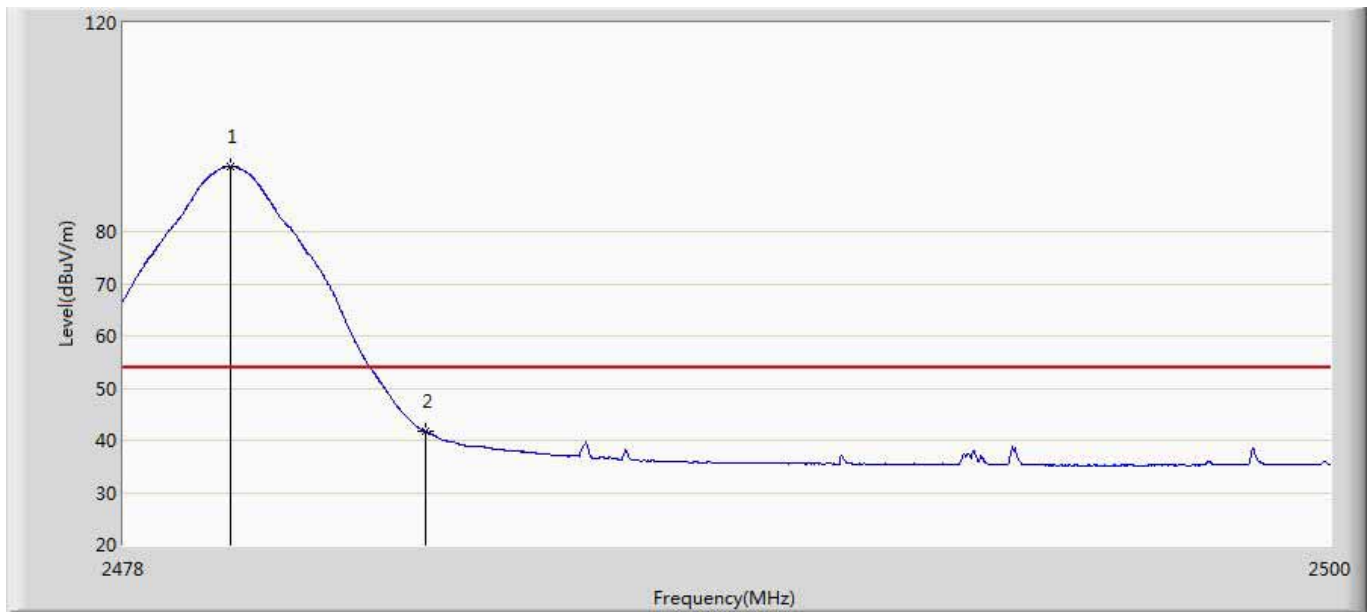

No	Mark	Frequency (MHz)	Measure Level (dBuV/m)	Reading Level (dBuV)	Over Limit (dB)	Limit (dBuV/m)	Factor (dB)	Type
1	*	2479.947	92.454	55.814	38.454	54.000	36.640	AV
2		2483.500	41.714	5.068	-12.286	54.000	36.646	AV

Engineer: Karl	
Site: AC5	Time: 2018/11/09 - 21:14
Limit: FCC_Part15.209_RE(3m)	Margin: 0
Probe: Horn_3117_00167055(1-18GHz)	Polarity: Horizontal
EUT: LED lamp	Power: AC 120V/60Hz
Note: Mode 1:Transmit at 2480MHz by Zigbee	

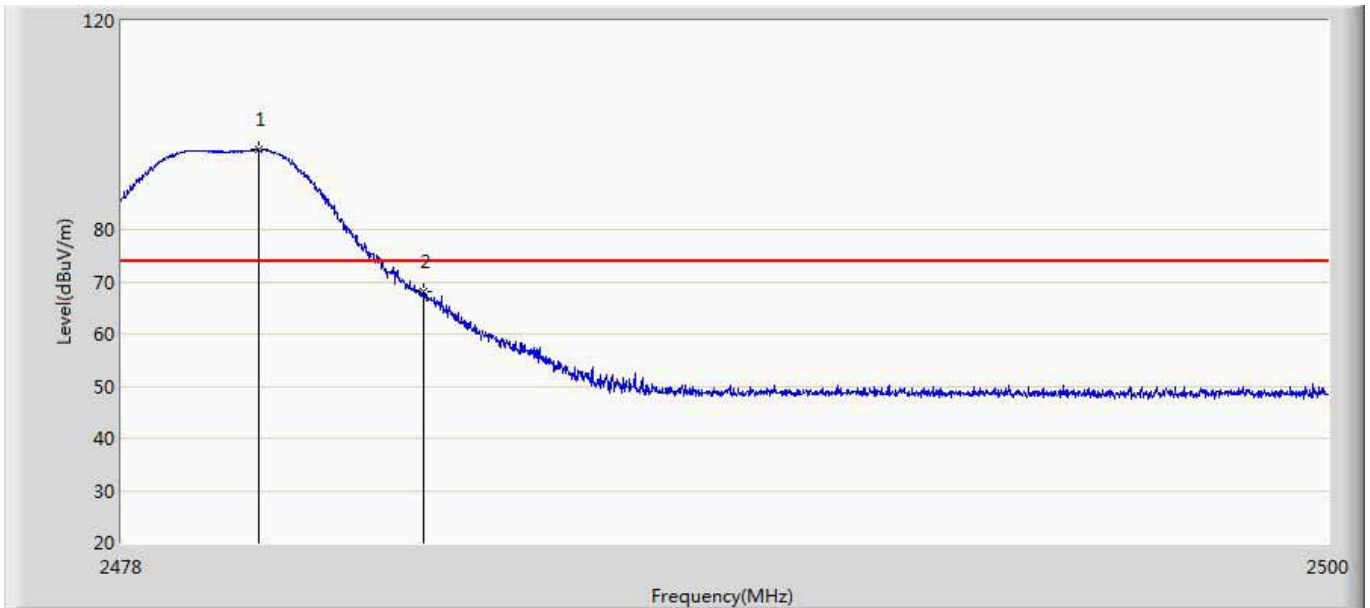

No	Mark	Frequency (MHz)	Measure Level (dBuV/m)	Reading Level (dBuV)	Over Limit (dB)	Limit (dBuV/m)	Factor (dB)	Type
1	*	2480.497	95.233	58.592	21.233	74.000	36.641	PK
2		2483.500	68.030	31.384	-5.970	74.000	36.646	PK

Engineer: Karl	
Site: AC5	Time: 2018/11/09 - 21:16
Limit: FCC_Part15.209_RE(3m)	Margin: 0
Probe: Horn_3117_00167055(1-18GHz)	Polarity: Vertical
EUT: LED lamp	Power: AC 120V/60Hz
Note: Mode 1:Transmit at 2480MHz by Zigbee	

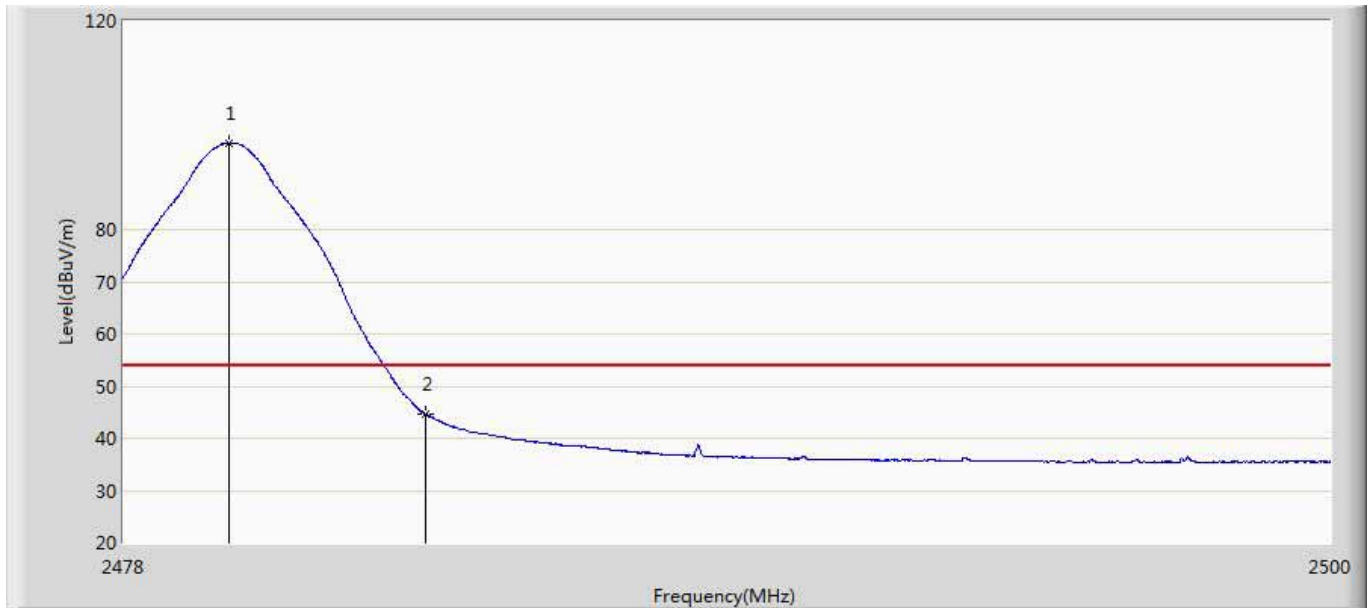

No	Mark	Frequency (MHz)	Measure Level (dBuV/m)	Reading Level (dBuV)	Over Limit (dB)	Limit (dBuV/m)	Factor (dB)	Type
1	*	2479.914	96.632	59.992	42.632	54.000	36.640	AV
2		2483.500	44.626	7.980	-9.374	54.000	36.646	AV

Engineer: Karl	
Site: AC5	Time: 2018/11/09 - 21:17
Limit: FCC_Part15.209_RE(3m)	Margin: 0
Probe: Horn_3117_00167055(1-18GHz)	Polarity: Vertical
EUT: LED lamp	Power: AC 120V/60Hz
Note: Mode 1:Transmit at 2480MHz by Zigbee	

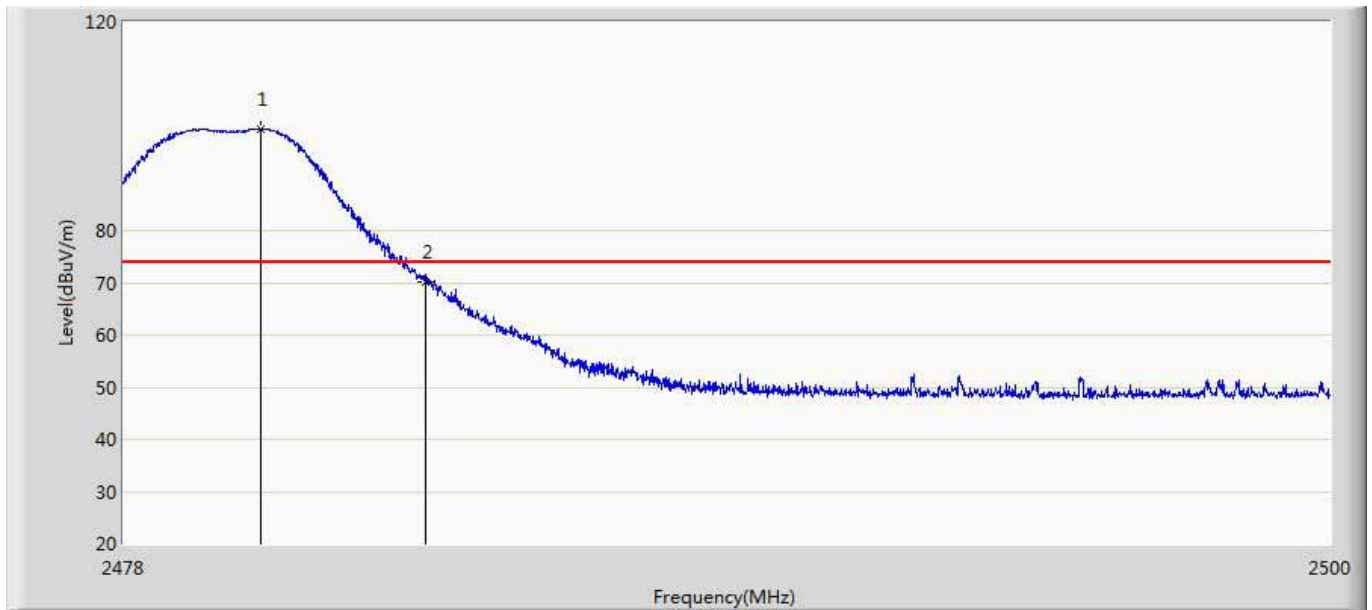

No	Mark	Frequency (MHz)	Measure Level (dBuV/m)	Reading Level (dBuV)	Over Limit (dB)	Limit (dBuV/m)	Factor (dB)	Type
1	*	2480.497	99.457	62.816	25.457	74.000	36.641	PK
2		2483.500	70.103	33.457	-3.897	74.000	36.646	PK

7. Occupied Bandwidth

7.1. Test Equipment

Occupied Bandwidth / TR-8					
Instrument	Manufacturer	Type No.	Serial No.	Cal. Date	Cal. Due Date
Spectrum Analyzer	Agilent	N9010A	MY48030494	2018.02.04	2019.02.03
EXA Spectrum Analyzer	Keysight	N9010A	MY55370495	2018.04.09	2019.04.08
MXA Signal Analyzer	Keysight	N9020A	MY56060147	2018.04.09	2019.04.08
Temperature/Humidity Meter	zhichen	ZC1-2	TR8-TH	2018.04.10	2019.04.09

Note: All equipment are calibrated with traceable calibrations. Each calibration is traceable to the national or international standards.

7.2. Test Setup

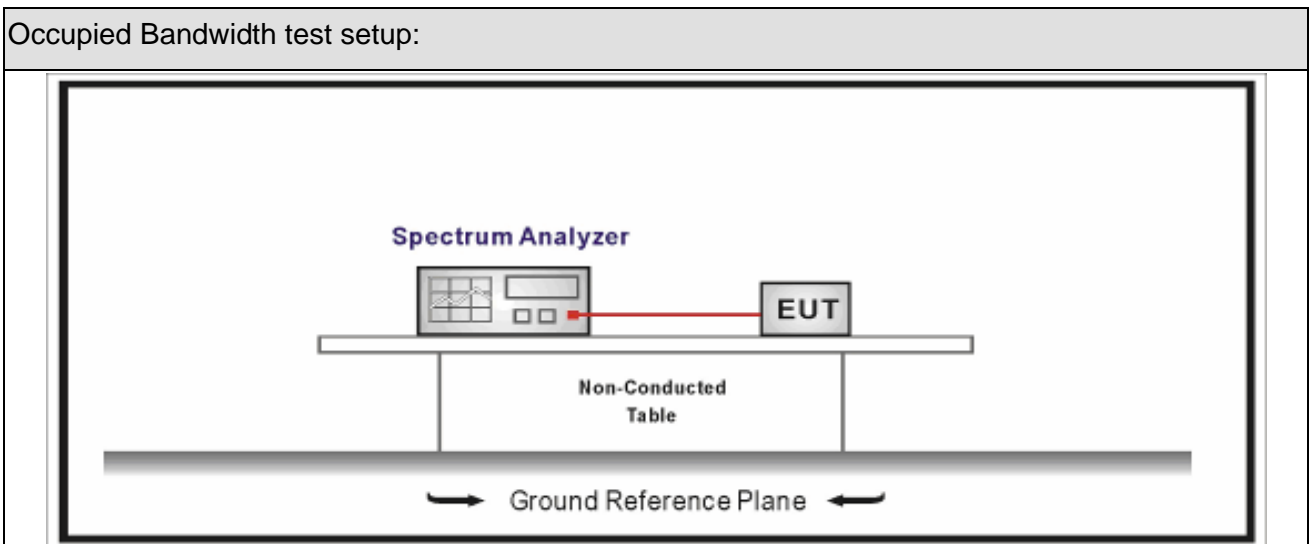





7.3. Limit

Occupied Bandwidth
Systems using digital modulation techniques operate in the 2400-2483.5 MHz. The minimum 6 dB bandwidth shall be at least 500 kHz

7.4. Test Procedure

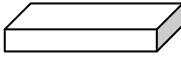
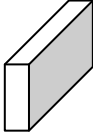
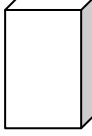
Test Method			
	Reference Rule	Chapter	Description
<input checked="" type="checkbox"/>	ANSI C63.10	11.8	DTS bandwidth
<input type="checkbox"/>	ANSI C63.10	11.8.1	Option 1
<input checked="" type="checkbox"/>	ANSI C63.10	11.8.2	Option 2

7.5. EUT test definition

Item	Occupied Bandwidth			
Device Category	<input type="checkbox"/>	Fixed point-to-point		
	<input type="checkbox"/>	Emit multiple directional beams, simultaneously or sequentially		
	<input checked="" type="checkbox"/>	Other cases		
Test mode	Mode 1			
Test method	<input type="checkbox"/>	Radiated		
		X Axis	Y Axis	Z Axis
				
		Worst Axis <input type="checkbox"/>	Worst Axis <input type="checkbox"/>	Worst Axis <input type="checkbox"/>
	<input checked="" type="checkbox"/>	Conducted		
	<input checked="" type="checkbox"/>	Chain 0		
				
<input type="checkbox"/>	Chain 0	Chain 1		
				
<input type="checkbox"/>	Chain 0	Chain 1	Chain 2	
				

7.6. Test Result

Product Name	: LED lamp	Power	: AC 120V/60Hz
Test Mode	: Mode 1	Test Site	: TR-8
Test Date	: 2018.11.08	Test engineer	: Tommie

Mode	CH.	Test Freq. (MHz)	99% Occupied Bandwidth (kHz)	6dB Occupied Bandwidth (kHz)	Limit (kHz)	Result
1	11	2405	2305.1	1701	>500	Pass
1	20	2450	2288	1683	>500	Pass
1	26	2480	2271.4	1648	>500	Pass

Note : The worst case of Occupied Bandwidth as below:

Mode 1 CH26 (2480MHz)

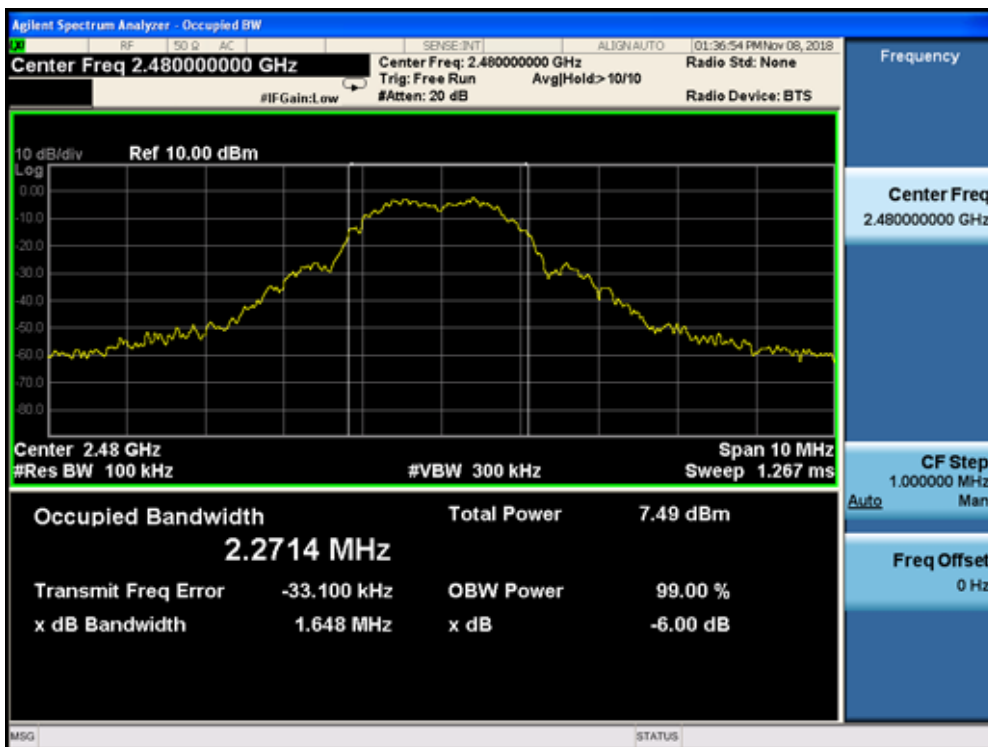

8. Fundamental emission output power

8.1. Test Equipment

Fundamental emission output power/ TR-8					
Instrument	Manufacturer	Type No.	Serial No.	Cal. Date	Cal. Due Date
Spectrum Analyzer	Agilent	E4446A	MY45300103	2018.01.04	2019.01.03
Spectrum Analyzer	Agilent	N9010A	MY48030494	2018.01.04	2019.01.03
Wideband Peak Power Meter	Anritsu	ML2495A	0905006	2018.10.14	2019.10.13
Power Sensor	Anritsu	MA2411B	0846014	2018.10.14	2019.10.13
Temperature/Humidity Meter	zhicheng	ZC1-2	TR8-TH	2018.04.10	2019.04.09

Note: All equipment are calibrated with traceable calibrations. Each calibration is traceable to the national or international standards.

8.2. Test Setup

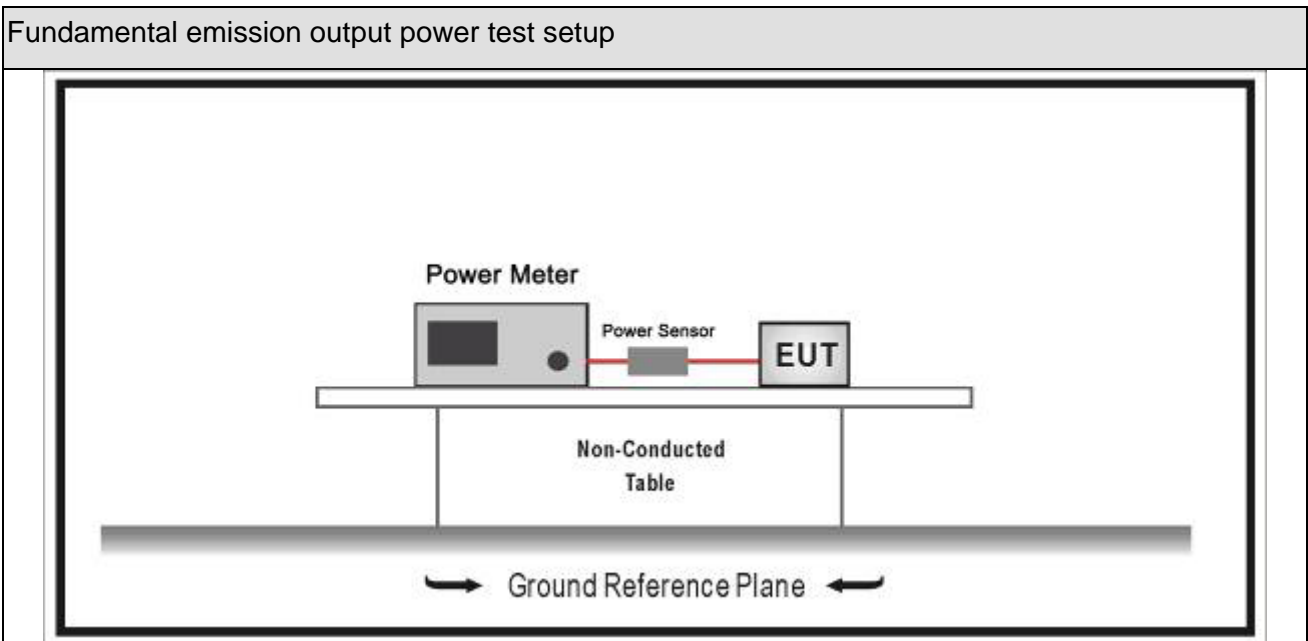





8.3. Limit

Fundamental emission output power Limit		
<input checked="" type="checkbox"/>	$G_{TX} < 6\text{dBi}$	$P_{out} \leq 30\text{dBm}$
<input type="checkbox"/>	$G_{TX} > 6\text{dBi}$	
<input type="checkbox"/>	Non-Fix point-point	$P_{out} \leq 30 - (G_{TX} - 6)$
<input type="checkbox"/>	Fix point-point	$P_{out} \leq 30 - [(G_{TX} - 6)]/3$
<input checked="" type="checkbox"/>	Point-to-multipoint	$P_{out} \leq 30 - (G_{TX} - 6)$
<input type="checkbox"/>	Overlap Beams	$P_{out} \leq 30 - [(G_{TX} - 6)]/3$
<input type="checkbox"/>	Aggregate power transmitted simultaneously on all beams	$P_{out} \leq 30 - [(G_{TX} - 6)]/3$
<input type="checkbox"/>	single directional beam	$P_{out} \leq 30 - [(G_{TX} - 6)]/3 + 8\text{dB}$
<p>Note 1 : G_{TX} directional gain of transmitting antennas.</p> <p>Note 2 : P_{out} is maximum peak conducted output power .</p>		

8.4. Test Procedure

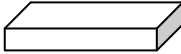
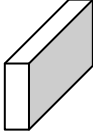
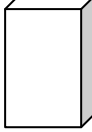
Fundamental emission output power Test Method						
	References Rule		Chapter	Description		
<input checked="" type="checkbox"/>	ANSI C63.10		11.9	Fundamental emission output power		
	<input checked="" type="checkbox"/>	ANSI C63.10		11.9.1	Maximum peak conducted output power	
		<input type="checkbox"/>	ANSI C63.10	11.9.1.1	RBW DTS bandwidth	
		<input type="checkbox"/>	ANSI C63.10	11.9.1.2	Integrated band power method	
		<input checked="" type="checkbox"/>	ANSI C63.10	11.9.1.3	PKPM1 Peak power meter method	
		<input type="checkbox"/>	ANSI C63.10		11.9.2	Maximum conducted (average) output power
		<input type="checkbox"/>	ANSI C63.10		11.9.2.2	Measurement using a spectrum analyzer (SA)
			<input type="checkbox"/>	ANSI C63.10	11.9.2.2.2	Method AVGSA-1(Duty cycle 98%)
			<input type="checkbox"/>	ANSI C63.10	11.9.2.2.3	Method AVGSA-1A(Duty cycle 98%)
			<input type="checkbox"/>	ANSI C63.10	11.9.2.2.4	Method AVGSA-2(Duty cycle 98%)
			<input type="checkbox"/>	ANSI C63.10	11.9.2.2.5	Method AVGSA-2A(Duty cycle 98%)
			<input type="checkbox"/>	ANSI C63.10	11.9.2.2.4	Method AVGSA-3
			<input type="checkbox"/>	ANSI C63.10	11.9.2.2.5	Method AVGSA-3A
		<input type="checkbox"/>	ANSI C63.10		11.9.2.3	Measurement using a power meter (PM)
			<input type="checkbox"/>	ANSI C63.10	11.9.2.3.1	Method AVGPM
			<input type="checkbox"/>	ANSI C63.10	11.9.2.3.2	Method AVGPM-G

8.5. EUT test definition

Item	Fundamental emission output power			
Device Category	<input type="checkbox"/>	Fixed point-to-point		
	<input type="checkbox"/>	Emit multiple directional beams, simultaneously or sequentially		
	<input checked="" type="checkbox"/>	Other cases		
Test mode	Mode 1			
Test method	<input type="checkbox"/>	Radiated		
		X Axis	Y Axis	Z Axis
				
		Worst Axis <input type="checkbox"/>	Worst Axis <input type="checkbox"/>	Worst Axis <input type="checkbox"/>
	<input checked="" type="checkbox"/>	Conducted		
	<input checked="" type="checkbox"/>	Chain 0		
				
	<input type="checkbox"/>	Chain 0	Chain 1	
				
	<input type="checkbox"/>	Chain 0	Chain 1	Chain 2
				

8.6. Test Result

Product Name	: LED lamp	Power	: AC 120V/60Hz
Test Mode	: Mode 1	Test Site	: TR-8
Test Date	: 2018.11.08	Test engineer	: Tommie

Mode	Channel	Test Frequency (MHz)	Measurement Power Output (dBm)	Limit (dBm)	Result
1	11	2405	10.537	30	Pass
1	20	2450	10.332	30	Pass
1	26	2480	9.757	30	Pass

9. Power Spectral Density

9.1. Test Equipment

Power Spectral Density / TR-8					
Instrument	Manufacturer	Type No.	Serial No.	Cal. Date	Cal. Due Date
Spectrum Analyzer	Agilent	N9010A	MY48030494	2018.02.04	2019.02.03
EXA Spectrum Analyzer	Keysight	N9010A	MY55370495	2018.04.09	2019.04.08
MXA Signal Analyzer	Keysight	N9020A	MY56060147	2018.04.09	2019.04.08
Temperature/Humidity Meter	zhichen	ZC1-2	TR8-TH	2018.04.10	2019.04.09

Note: All equipment are calibrated with traceable calibrations. Each calibration is traceable to the national or international standards.

9.2. Test Setup

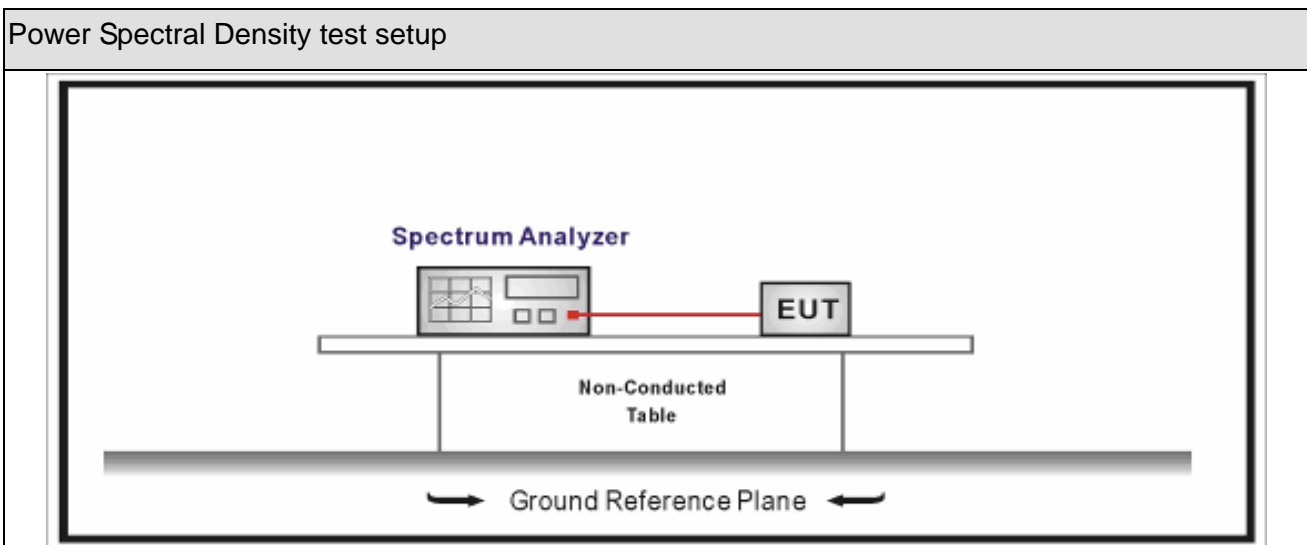

9.3. Limit

Power Spectral Density Limit
Power Spectral Density 8dBm/3kHz

9.4. Test Procedure

Power Spectral Density Test Method			
	References Rule	Chapter	Description
<input checked="" type="checkbox"/>	ANSI C63.10	11.10	Maximum power spectral density level in the fundamental emission
<input checked="" type="checkbox"/>	ANSI C63.10	11.10.2	Method PKPSD (peak PSD)
<input type="checkbox"/>	ANSI C63.10	11.10.3	Method AVGPSD-1(Duty cycle 98%)
<input type="checkbox"/>	ANSI C63.10	11.10.4	Method AVGPSD-1A(Duty cycle 98%)
<input type="checkbox"/>	ANSI C63.10	11.10.5	Method AVGPSD-2(Duty cycle < 98%)
<input type="checkbox"/>	ANSI C63.10	11.10.6	Method AVGPSD-2A(Duty cycle < 98%)
<input type="checkbox"/>	ANSI C63.10	11.10.7	Method AVGPSD-3
<input type="checkbox"/>	ANSI C63.10	11.10.8	Method AVGPSD-3A

9.5. EUT test definition

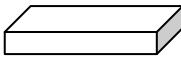
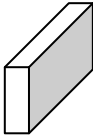
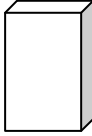
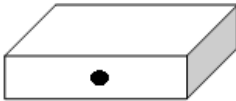
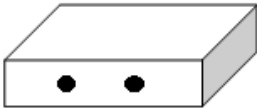
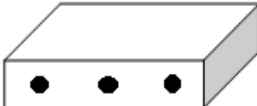
Item	Power Spectral Density Test Method			
Device Category	<input type="checkbox"/>	Fixed point-to-point		
	<input type="checkbox"/>	Emit multiple directional beams, simultaneously or sequentially		
	<input checked="" type="checkbox"/>	Other cases		
Test mode	Mode 1			
Test method	<input type="checkbox"/>	Radiated		
		X Axis	Y Axis	Z Axis
				
		Worst Axis <input type="checkbox"/>	Worst Axis <input type="checkbox"/>	Worst Axis <input type="checkbox"/>
	<input checked="" type="checkbox"/>	Conducted		
	<input checked="" type="checkbox"/>	Chain 0		
				
	<input type="checkbox"/>	Chain 0	Chain 1	
				
	<input type="checkbox"/>	Chain 0	Chain 1	Chain 2
				

9.6. Test Result

Product Name	: LED lamp	Power	: AC 120V/60Hz
Test Mode	: Mode 1	Test Site	: TR-8
Test Date	: 2018.11.08	Test engineer	: Tommie

Mode	Channel	Test Frequency (MHz)	Measurement PSD (dBm/3kHz)	Total PSD (dBm/3kHz)	Limit (dBm/3kHz)	Result
1	11	2405	-6.217	-6.217	8	Pass
1	15	2425	-7.684	-7.684	8	Pass
1	20	2450	-7.268	-7.268	8	Pass
1	25	2475	-7.080	-7.080	8	Pass
1	26	2480	-7.775	-7.775	8	Pass

Note : The worst case of Power Spectral Density as below:

Mode 1 CH11(2405MHz)

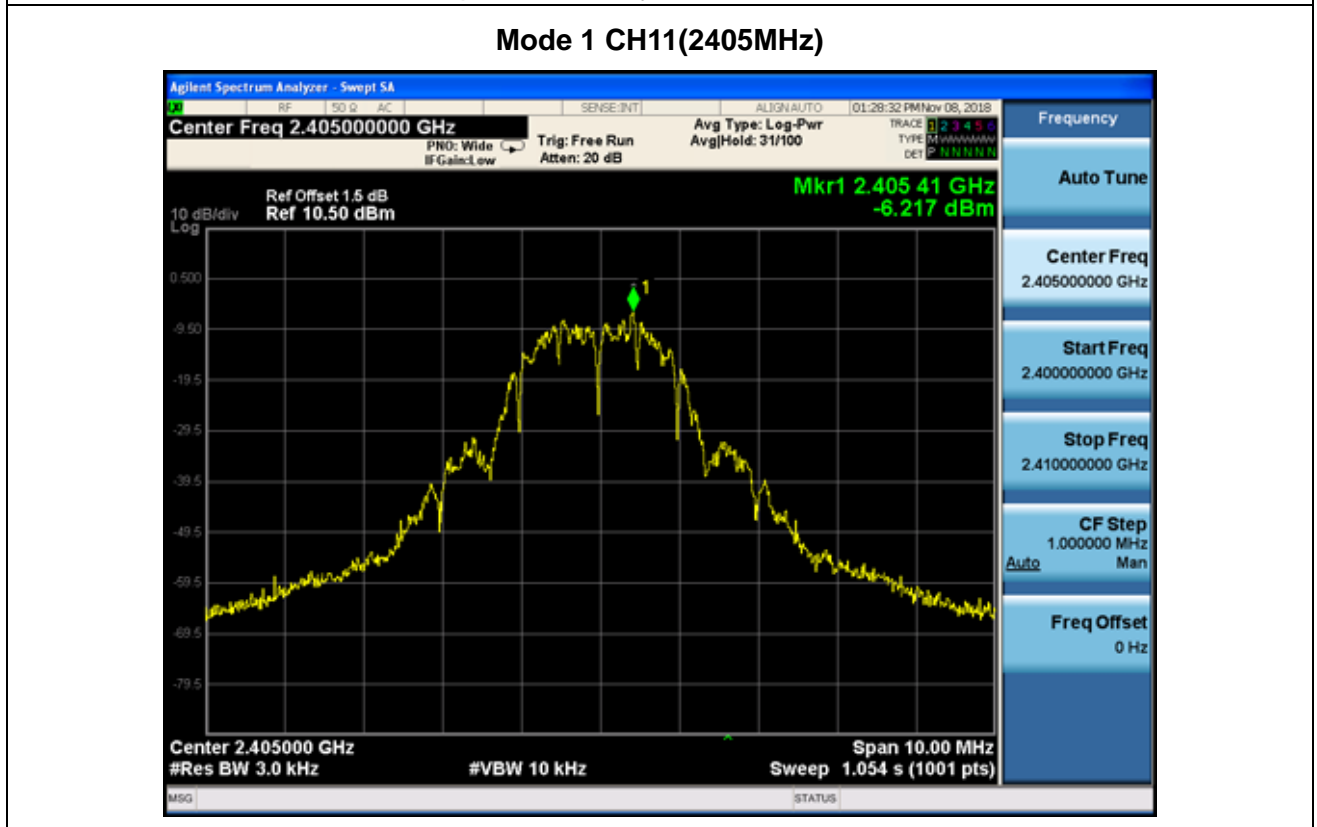

10. Antenna Requirement

10.1. Limit

Antenna Requirement Limit
<p>An intentional radiator shall be designed to ensure that no antenna other than that furnished by the responsible party shall be used with the device. The use of a permanently attached antenna or of an antenna that uses a unique coupling to the intentional radiator shall be considered sufficient to comply with the provisions of this section. The manufacturer may design the unit so that a broken antenna can be replaced by the user, but the use of a standard antenna jack or electrical connector is prohibited. This requirement does not apply to carrier current devices or to devices operated under the provisions of § 15.211, § 15.213, § 15.217, § 15.219, or § 15.221. Further, this requirement does not apply to intentional radiators that must be professionally installed, such as perimeter protection systems and some field disturbance sensors, or to other intentional radiators which, in accordance with § 15.31(d), must be measured at the installation site. However, the installer shall be responsible for ensuring that the proper antenna is employed so that the limits in this part are not exceeded.</p>

10.2. Antenna Connector Construction

Antenna Connector Construction	
<input checked="" type="checkbox"/>	The use of a permanently attached antenna
<input type="checkbox"/>	The antenna use of a unique coupling to the intentional radiator
<input type="checkbox"/>	The use of a nonstandard antenna jack or electrical connector
Please refer to the attached document “ Internal Photograph ” to show the antenna connector.	

_____ The End _____