



Test Report

FCC Part15 Subpart C & ISED RSS-247 Issue 2

Product Name : LED lamp
Model No. : 9290022167
FCC ID : 2AGBW9290022167X
IC : 20812-2167X

Applicant : Signify (China) Investment Co., Ltd.
Address : Building no.9, Lane 888, Tianlin Road, Minhang
District, Shanghai 200233, China

Date of Receipt : May. 22, 2019
Issued Date : May. 29, 2019
Report No. : 1952139R-RF-US-P06V02
Report Version : V 1.0

Note: This appendix report is based on DEKRA report No. 1782159R-RF-US-P06V02, only modify the EUT rating, Brand name, Model No. , Applicant, Manufacturer, FCC/IC ID and Address.

The test results relate only to the samples tested.

The test results shown in the test report are traceable to the national/international standard through the calibration of the equipment and evaluated measurement uncertainty herein.

This report must not be used to claim product endorsement by A2LA or any agency of the government.

The test report shall not be reproduced without the written approval of DEKRA Testing & Certification (Suzhou) Co., Ltd.

Test Report Certification

Issued Date : May. 29, 2019
Report No. : 1952139R-RF-US-P06V02



Product Name : LED lamp
 Applicant : Signify (China) Investment Co., Ltd.
 Address : Building no.9, Lane 888, Tianlin Road, Minhang District, Shanghai 200233, China
 Manufacturer : Signify (China) Investment Co., Ltd.
 Address : Building no.9, Lane 888, Tianlin Road, Minhang District, Shanghai 200233, China
 Model No. : 9290022167
 FCC ID : 2AGBW9290022167X
 IC : 20812-2167X
 Brand Name : PHILIPS
 EUT Voltage : 110-130 Vac, 50-60 Hz, 9W
 Test Voltage : AC 120V/60Hz
 Applicable Standard : FCC CFR Title 47 Part 15 Subpart C: 2016
 ANSI C63.4:2014; ANSI C63.10:2013;
 KDB 558074 D01v04
 ISED RSS-Gen Issue 4 / RSS-247 Issue 2
 Test Result : Complied
 Performed Location : DEKRA Testing & Certification (Suzhou) Co., Ltd.
 No.99 Hongye Rd., Suzhou Industrial Park, Suzhou, 215006, Jiangsu, China
 TEL: +86-512-6251-5088 / FAX: +86-512-6251-5098
 FCC Registration Number: CN1199; IC Lab Code: 4075B

Documented By : *Kitty Li*
 (Adm. Specialist: Kitty Li)

Reviewed By : *Frank He*
 (Senior Project Manager: Frank He)

Approved By : *Jack Zhang*
 (Engineering Supervisor: Jack Zhang)

TABLE OF CONTENTS

Description	Page
1. General Information	6
1.1. EUT Description	6
1.2. Working Frequency of Each Channel:	6
1.3. Antenna information	7
1.4. Mode of Operation.....	8
1.5. Tested System Details	8
1.6. Configuration of Tested System.....	9
1.7. EUT Exercise Software.....	10
2. Technical Test	11
2.1. Summary of Test Result.....	11
2.2. Test Environment.....	13
2.3. Measurement Uncertainty.....	13
3. AC Power Line Conducted Emission	14
3.1. Test Equipment.....	14
3.2. Test Setup.....	14
3.3. Limit.....	15
3.4. Test Procedure	15
3.5. Test Result.....	16
4. Emissions in restricted frequency bands	22
4.1. Test Equipment.....	22
4.2. Test Setup.....	23
4.3. Limit.....	24
4.4. Test Procedure	27
4.5. EUT test Axis definition.....	28
4.6. Test Result.....	29
5. Emissions in non-restricted frequency bands	45
5.1. Test Equipment.....	45
5.2. Test Setup.....	45
5.3. Limit.....	46
5.4. Test Procedure	47
5.5. EUT test Axis definition.....	48
5.6. Test Result.....	49
6. Radiated Emission Band Edge	50
6.1. Test Equipment.....	50
6.2. Test Setup.....	51
6.3. Limit.....	51
6.4. Test Procedure	52

- 6.5. EUT test definition 53
- 6.6. Duty Cycle 54
- 6.7. Test Result 55
- 7. Occupied Bandwidth 79
 - 7.1. Test Equipment..... 79
 - 7.2. Test Setup..... 79
 - 7.3. Limit..... 80
 - 7.4. Test Procedure 80
 - 7.5. EUT test definition 81
 - 7.6. Test Result..... 82
- 8. Fundamental emission output power 83
 - 8.1. Test Equipment..... 83
 - 8.2. Test Setup..... 83
 - 8.3. Limit..... 84
 - 8.4. Test Procedure 85
 - 8.5. EUT test definition 86
 - 8.6. Test Result..... 87
- 9. Power Spectral Density 88
 - 9.1. Test Equipment..... 88
 - 9.2. Test Setup..... 88
 - 9.3. Limit..... 88
 - 9.4. Test Procedure 89
 - 9.5. EUT test definition 90
 - 9.6. Test Result..... 91
- 10. Antenna Requirement..... 92
 - 10.1. Limit..... 92
 - 10.2. Antenna Connector Construction..... 92

History of This Test Report

REPORT NO.	VERSION	DESCRIPTION	ISSUED DATE
1952139R-RF-US-P06V02	V1.0	Initial Issued Report	May. 29, 2019

1. General Information

1.1. EUT Description

Product Name	LED Lamp
Brand Name	PHILIPS
Model No.	9290022167
EUT Voltage	110-130 Vac, 50-60 Hz, 9W
Frequency Range	2405 ~ 2480MHz
Channel Number	16
Type of Modulation	O-QPSK
Data Rate	250kbps
Antenna Type	Reference to Antenna List
Peak Antenna Gain	Reference to Antenna List

1.2. Working Frequency of Each Channel:

Zigbee Working Frequency of Each Channel:							
Channel	Frequency	Channel	Frequency	Channel	Frequency	Channel	Frequency
11	2405 MHz	12	2410 MHz	13	2415 MHz	14	2420 MHz
15	2425 MHz	16	2430 MHz	17	2435 MHz	18	2440 MHz
19	2445 MHz	20	2450 MHz	21	2455 MHz	22	2460 MHz
23	2465 MHz	24	2470 MHz	25	2475 MHz	26	2480 MHz

1.3. Antenna information

Antenna manufacturer	N/A		
Antenna Delivery	<input checked="" type="checkbox"/> 1*TX+1*RX	<input type="checkbox"/> 2*TX+2*RX	<input type="checkbox"/> 3*TX+3*RX
Antenna technology	<input checked="" type="checkbox"/> SISO		
	<input type="checkbox"/> MIMO	<input type="checkbox"/> Basic	
		<input type="checkbox"/> CDD	
		<input type="checkbox"/> Beam-forming	
Antenna Type	<input type="checkbox"/> External	<input type="checkbox"/> Dipole	
	<input checked="" type="checkbox"/> Internal	<input type="checkbox"/> PIFA	
		<input checked="" type="checkbox"/> PCB	
		<input type="checkbox"/> Ceramic Chip Antenna	
		<input type="checkbox"/> Metal plate type F antenna	
Antenna Gain	-2.08dBi		

1.4. Mode of Operation

DEKRA has verified the construction and function in typical operation. See the different modes shown in this test report and defined as:

Test Modes List
Mode 1: Transmit by Zigbee

1.5. Tested System Details

The types for all equipment, plus descriptions of all cables used in the tested system (including inserted cards) are:

No.	Product	Manufacturer	Model No.	Serial No.	Power Cord
1	Notebook	Think Pad	2526	LV-A3285	Power by adapter
2	Control board	PHILIPS	N/A	N/A	N/A
A	USB Control Cable	N/A	N/A	N/A	Shield, 1m
B	USB Control Cable	N/A	N/A	N/A	Shield, 10m

1.6. Configuration of Tested System

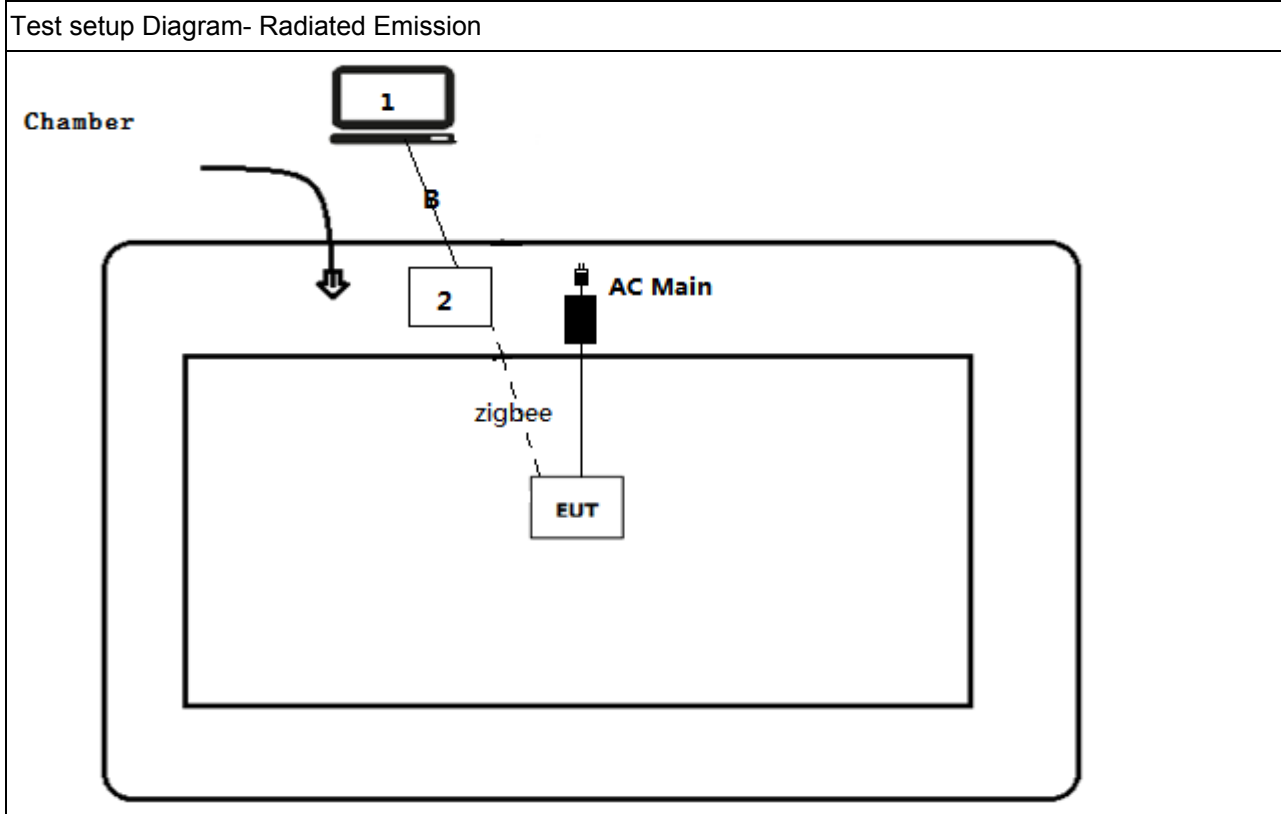
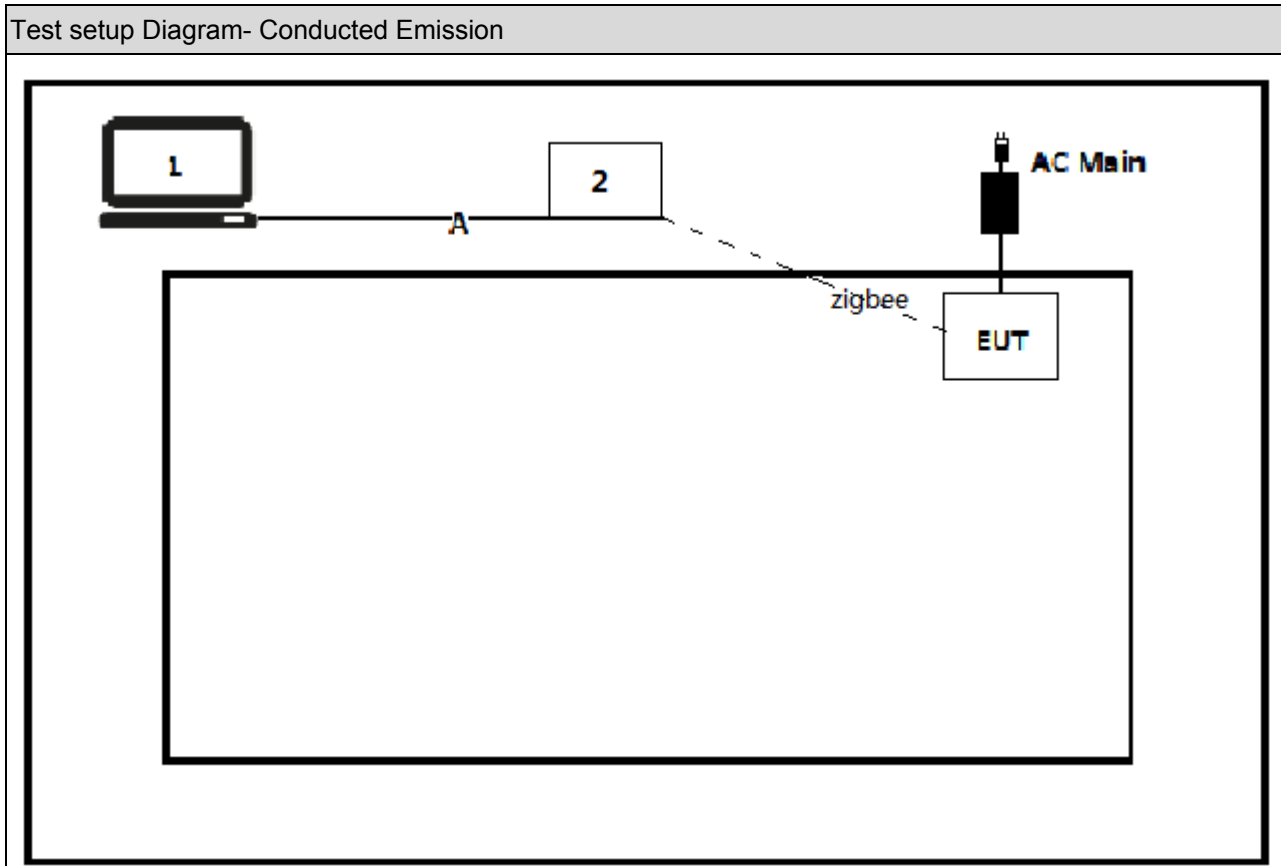

1.7. EUT Exercise Software

1	Setup the EUT and simulators as shown on above.
2	Turn on the power of all equipment.
3	Run the software, and set the test mode and channel, then press OK to start continue receive.

2. Technical Test

2.1. Summary of Test Result

For FCC rule

Performed Test Item	Normative References	Limit	Result
AC Power Line Conducted Emission	FCC CFR Title 47 Part 15 Subpart C: 2016 Section 15.207	FCC 15.207	PASS
Emissions in restricted frequency bands	FCC CFR Title 47 Part 15 Subpart C: 2016 Section 15.209	FCC 15.209	PASS
Emissions in non-restricted frequency bands	FCC CFR Title 47 Part 15 Subpart C: 2016 Section 15.247(d)	20dBc	PASS
Radiated Emission Band Edge	FCC CFR Title 47 Part 15 Subpart C: 2016 15.247(d)	FCC 15.209	PASS
Occupied Bandwidth	FCC CFR Title 47 Part 15 Subpart C: 2016 Section 15.247(a)(2)	500kHz	PASS
Fundamental emission output power	FCC CFR Title 47 Part 15 Subpart C: 2016 Section 15.247(b)(3)	30dBm	PASS
Power Spectral Density	FCC CFR Title 47 Part 15 Subpart C: 2016 Section 15.247(e)	8dBm/3kHz	PASS
Antenna Requirement	FCC CFR Title 47 Part 15 Subpart C: 2016 Section 15.203	FCC 15.203	PASS

For IC rule

Performed Test Item	Normative References	Limit	Result
AC Power Line Conducted Emission	RSS-Gen Issue 4 Section 8.8	RSS-Gen	PASS
Emissions in restricted frequency bands	RSS-Gen Issue 4 Section 8.9	RSS-Gen	PASS
Emissions in non-restricted frequency bands	RSS-247 Issue 2 Section A5.5	20dBc	PASS
Radiated Emission Band Edge	RSS-247 Issue 2 Section A5.5	RSS-247	PASS
Occupied Bandwidth	RSS-Gen Issue 4 Section 6.6 RSS-247 Issue 2 Section A5.2(1)	500kHz	PASS
Fundamental emission output power	RSS-247 Issue 2 Section A5.4(4)	30dBm	PASS
Power Spectral Density	RSS-247 Issue 2 Section A5.2(2)	8dBm/3kHz	PASS
Antenna Requirement	RSS-Gen Issue 4 Section 8.3	RSS-Gen Issue 4	PASS

2.2. Test Environment

Items	Required (IEC 68-1)	Actual
Temperature (°C)	15-35	21
Humidity (%RH)	25-75	50
Barometric pressure (mbar)	860-1060	950-1000

2.3. Measurement Uncertainty

Test Items	Uncertainty
AC Power Line Conducted Emission	$\pm 2.02\text{dB}$
Radiated Emission	Below 1GHz $\pm 3.8\text{ dB}$
	Above 1GHz $\pm 3.9\text{ dB}$
RF Antenna Port Conducted Emission	$\pm 1.27\text{dB}$
Radiated Emission Band Edge	$\pm 3.9\text{dB}$
Occupied Bandwidth	$\pm 1\text{kHz}$
Power Spectral Density	$\pm 1.27\text{dB}$

3. AC Power Line Conducted Emission

3.1. Test Equipment

AC Power Line Conducted Emission / TR-1				
Instrument	Manufacturer	Type No.	Serial No.	Cal. Due Date
EMI Test Receiver	R&S	ESCI	100906	2018.03.04
Two-Line V-Network	R&S	ENV 216	101189	2018.07.15
Two-Line V-Network	R&S	ENV 216	101044	2018.09.15
50ohm Coaxial Switch	Anritsu	MP59B	6200464462	N/A
50ohm Termination	SHX	TF2	07081402	2018.09.15
Temperature/Humidity Meter	Zhichen	ZC1-2	TR1-TH	2019.01.03

Note: All equipment are calibrated with traceable calibrations. Each calibration is traceable to the national or international standards.

3.2. Test Setup

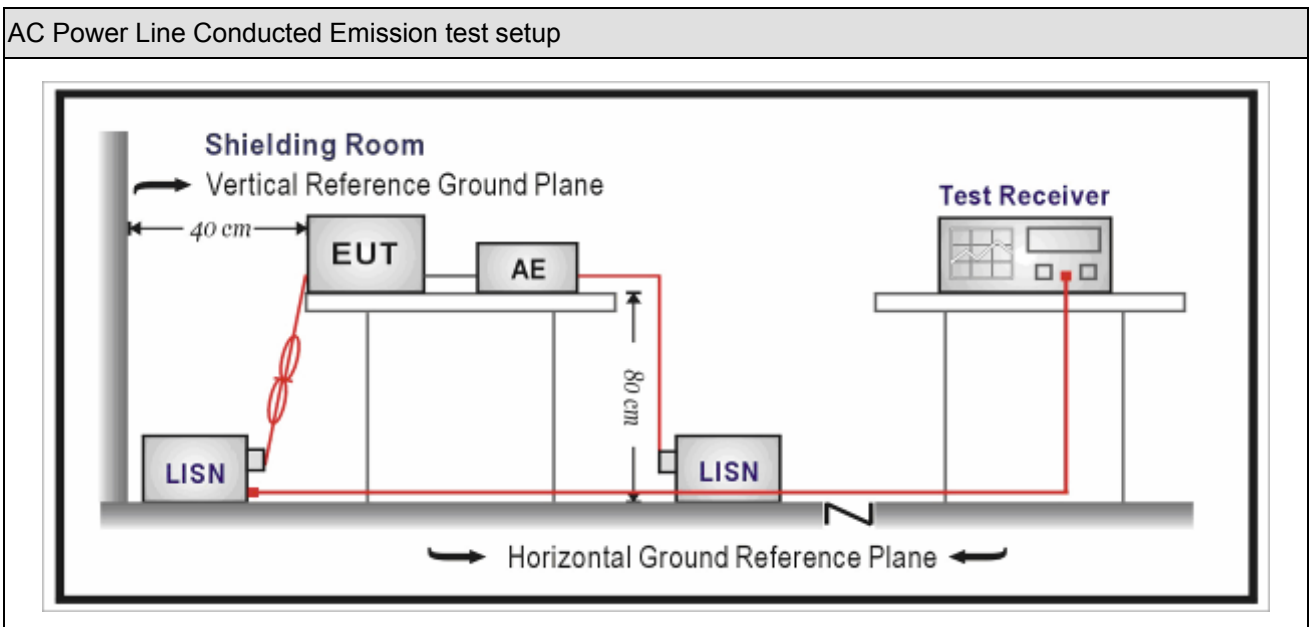

3.3. Limit

Frequency of Emission (MHz)	Conducted Limit	
	Quasi-peak (dB μ V)	Average (dB μ V)
0.15-0.5	66 to 56	56 to 46
0.5-5	56	46
5-30	60	50

Note 1: The lower limit shall apply at the transition frequencies.
 Note 2: The limit decreases linearly with the logarithm of the frequency in the range 0.15 MHz to 0.5 MHz.

3.4. Test Procedure

Test Method			
	References Rule	Chapter	Item
<input checked="" type="checkbox"/>	ANSI C63.10-2013	6.2	Standard test method for ac power-line conducted emissions from unlicensed wireless devices
<input checked="" type="checkbox"/>	ANSI C63.4-2014	7	AC power-line conducted emission measurements

3.5. Test Result

Test result for Alvis+Diodes:

Engineer: Nino	
Site: TR1	Time: 2017/09/08 - 10:49
Limit: FCC_Part15.107_CE_AC Power_ClassB	Margin: 0
Probe: ENV216_101190(0.009-30MHz)	Polarity: Line
EUT: LED lamp	Power: AC 120V/60Hz
Note: Mode 1:Transmit at 2450MHz by zigbee	

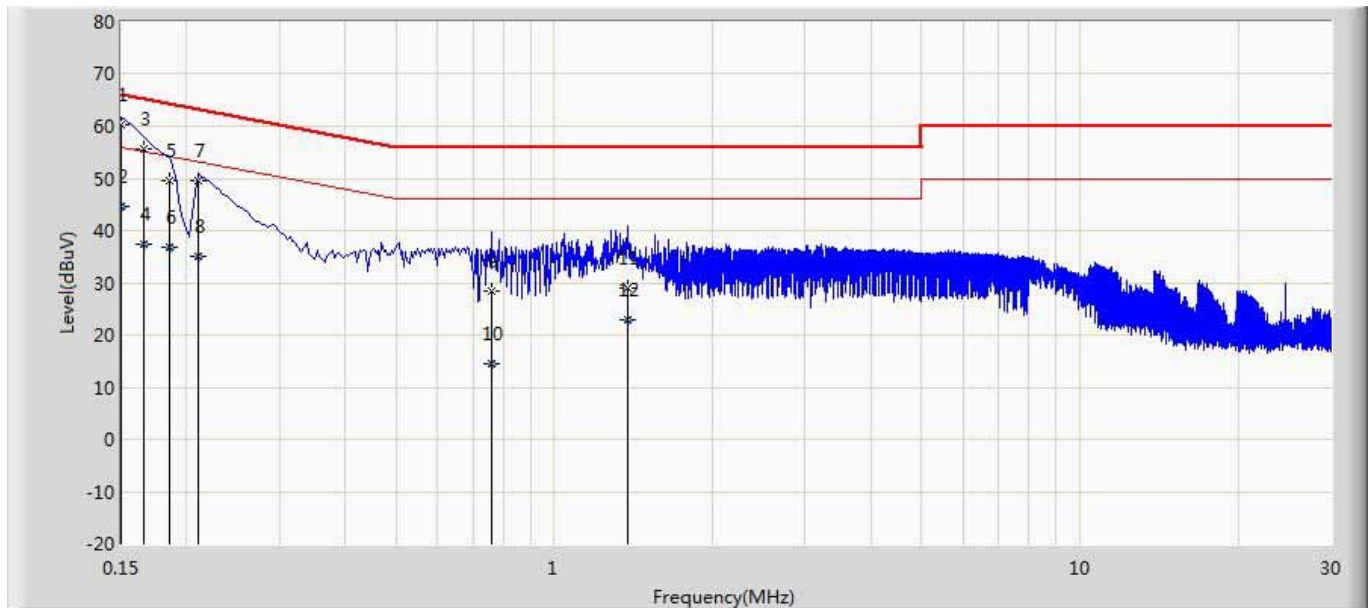

No	Mark	Frequency (MHz)	Measure Level (dBuV)	Reading Level (dBuV)	Over Limit (dB)	Limit (dBuV)	Probe (dB)	Cable (dB)	Amp (dB)	Type
1	*	0.150	60.363	50.728	-5.637	66.000	9.610	0.025	0.000	QP
2		0.150	44.645	35.010	-11.355	56.000	9.610	0.025	0.000	AV
3		0.166	55.751	46.118	-9.407	65.158	9.607	0.027	0.000	QP
4		0.166	37.261	27.628	-17.897	55.158	9.607	0.027	0.000	AV
5		0.186	49.475	39.844	-14.739	64.213	9.603	0.028	0.000	QP
6		0.186	36.918	27.287	-17.295	54.213	9.603	0.028	0.000	AV
7		0.210	49.565	39.936	-13.640	63.205	9.601	0.029	0.000	QP
8		0.210	35.096	25.467	-18.109	53.205	9.601	0.029	0.000	AV
9		0.758	28.380	18.726	-27.620	56.000	9.602	0.051	0.000	QP
10		0.758	14.572	4.919	-31.428	46.000	9.602	0.051	0.000	AV
11		1.382	29.042	19.362	-26.958	56.000	9.610	0.070	0.000	QP
12		1.382	22.788	13.108	-23.212	46.000	9.610	0.070	0.000	AV

Note:

1. All Readings below 1GHz are Quasi-Peak, above are performed with peak and/or average measurements as necessary.

2. " * ", means this data is the worst emission level.

3. Measurement Level = Reading Level + Factor(Probe+Cable-Amp).

Engineer: Nino	
Site: TR1	Time: 2017/09/08 - 10:55
Limit: FCC_Part15.107_CE_AC Power_ClassB	Margin: 0
Probe: ENV216_101190(0.009-30MHz)	Polarity: Neutral
EUT: LED lamp	Power: AC 120V/60Hz
Note: Mode 1:Transmit at 2450MHz by zigbee	

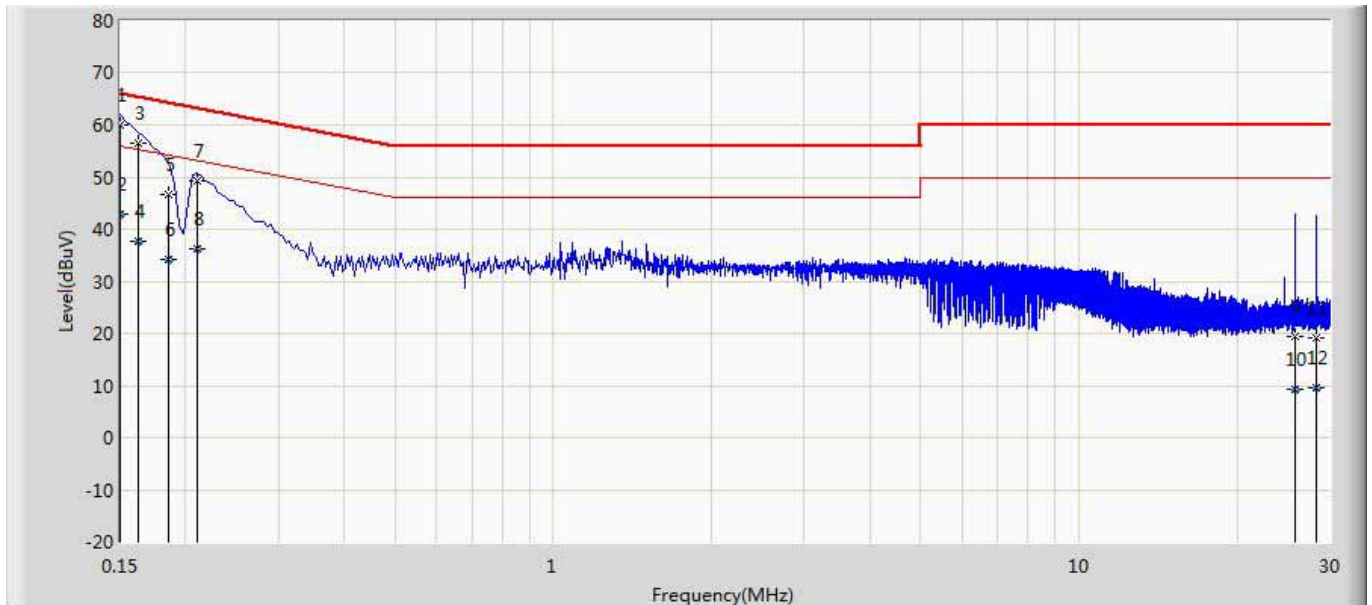

No	Mark	Frequency (MHz)	Measure Level (dBuV)	Reading Level (dBuV)	Over Limit (dB)	Limit (dBuV)	Probe (dB)	Cable (dB)	Amp (dB)	Type
1	*	0.150	59.969	50.350	-6.031	66.000	9.594	0.025	0.000	QP
2		0.150	42.884	33.265	-13.116	56.000	9.594	0.025	0.000	AV
3		0.162	56.615	46.996	-8.746	65.361	9.593	0.026	0.000	QP
4		0.162	37.800	28.182	-17.560	55.361	9.593	0.026	0.000	AV
5		0.186	46.535	36.909	-17.679	64.213	9.597	0.028	0.000	QP
6		0.186	34.234	24.609	-19.979	54.213	9.597	0.028	0.000	AV
7		0.210	49.336	39.708	-13.869	63.205	9.599	0.029	0.000	QP
8		0.210	36.199	26.572	-17.006	53.205	9.599	0.029	0.000	AV
9		25.786	19.391	8.411	-40.609	60.000	10.651	0.330	0.000	QP
10		25.786	9.150	-1.831	-40.850	50.000	10.651	0.330	0.000	AV
11		28.202	19.039	8.072	-40.961	60.000	10.622	0.346	0.000	QP
12		28.202	9.422	-1.546	-40.578	50.000	10.622	0.346	0.000	AV

Note:

1. All Readings below 1GHz are Quasi-Peak, above are performed with peak and/or average measurements as necessary.

2. " * ", means this data is the worst emission level.

3. Measurement Level = Reading Level + Factor(Probe+Cable-Amp).

Test result for Alvis+Murata:

Engineer: Nino	
Site: TR1	Time: 2017/09/08
Limit: FCC_Part15.107_CE_AC Power_ClassB	Margin: 0
Probe: ENV216_101190(0.009-30MHz)	Polarity: Line
EUT: LED Lamp	Power: AC 120V/60Hz
Note: Mode 1:Transmit at 2450MHz by zigbee	

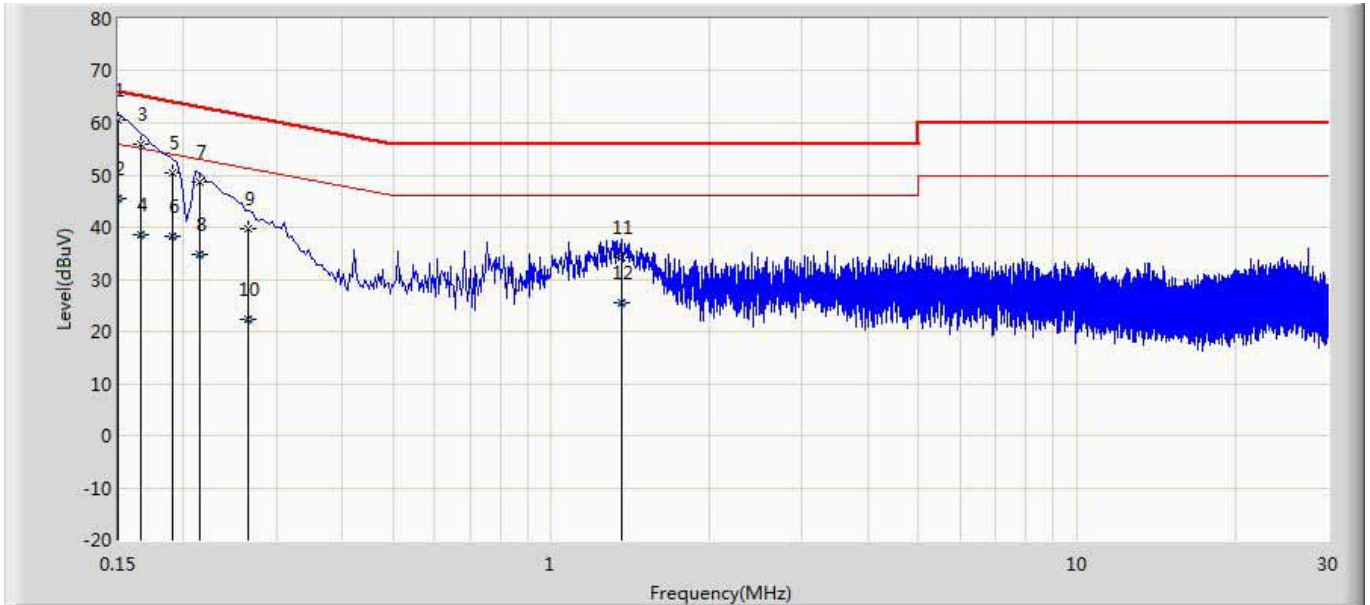

No	Mark	Frequency (MHz)	Measure Level (dBuV)	Reading Level (dBuV)	Over Limit (dB)	Limit (dBuV)	Probe (dB)	Cable (dB)	Amp (dB)	Type
1	*	0.150	60.692	51.057	-5.308	66.000	9.610	0.025	0.000	QP
2		0.150	45.539	35.904	-10.461	56.000	9.610	0.025	0.000	AV
3		0.166	56.078	46.445	-9.080	65.158	9.607	0.027	0.000	QP
4		0.166	38.672	29.039	-16.486	55.158	9.607	0.027	0.000	AV
5		0.190	50.552	40.922	-13.485	64.037	9.602	0.028	0.000	QP
6		0.190	38.156	28.526	-15.881	54.037	9.602	0.028	0.000	AV
7		0.214	48.817	39.187	-14.232	63.049	9.600	0.029	0.000	QP
8		0.214	34.640	25.010	-18.409	53.049	9.600	0.029	0.000	AV
9		0.266	39.573	29.941	-21.669	61.242	9.600	0.033	0.000	QP
10		0.266	22.292	12.660	-28.950	51.242	9.600	0.033	0.000	AV
11		1.358	34.346	24.666	-21.654	56.000	9.610	0.070	0.000	QP
12		1.358	25.614	15.934	-20.386	46.000	9.610	0.070	0.000	AV

Note:

1. " * ", means this data is the worst emission level.
2. Measurement Level = Reading Level + Factor(Probe+Cable-Amp).

Engineer: Nino	
Site: TR1	Time: 2017/09/08
Limit: FCC_Part15.107_CE_AC Power_ClassB	Margin: 0
Probe: ENV216_101190(0.009-30MHz)	Polarity: Neutral
EUT: LED Lamp	Power: AC 120V/60Hz
Note: Mode 1:Transmit at 2450MHz by zigbee	

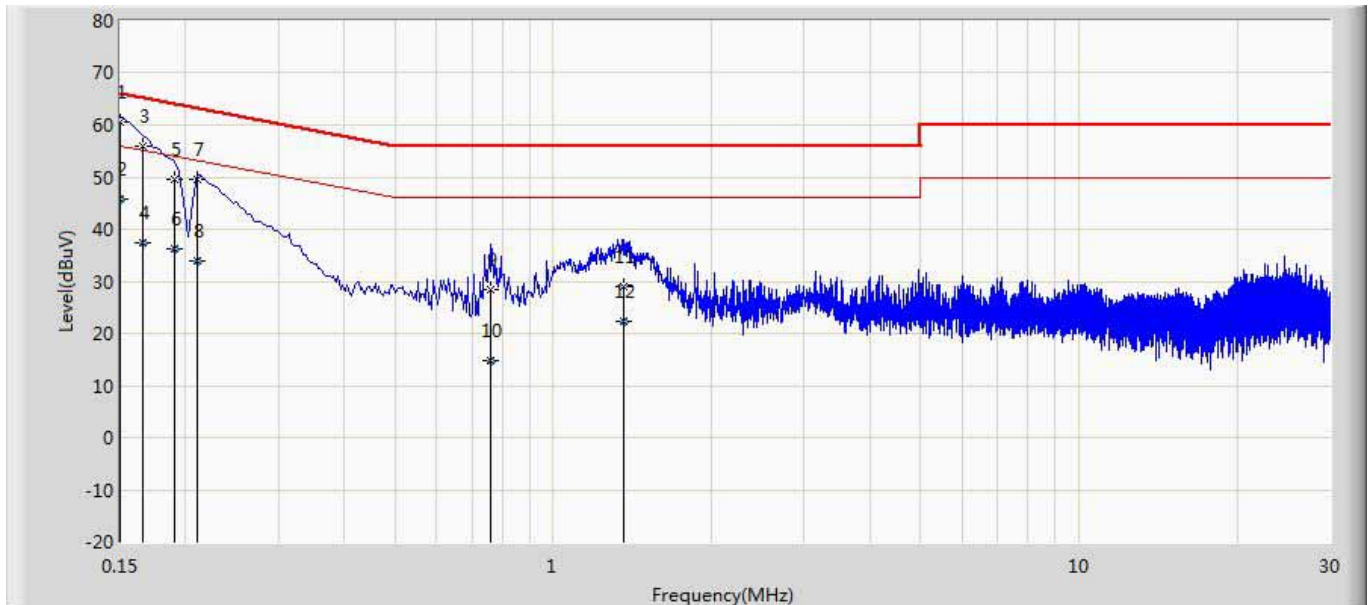

No	Mark	Frequency (MHz)	Measure Level (dBuV)	Reading Level (dBuV)	Over Limit (dB)	Limit (dBuV)	Probe (dB)	Cable (dB)	Amp (dB)	Type
1	*	0.150	60.550	50.931	-5.450	66.000	9.594	0.025	0.000	QP
2		0.150	45.685	36.067	-10.315	56.000	9.594	0.025	0.000	AV
3		0.166	55.958	46.338	-9.200	65.158	9.593	0.027	0.000	QP
4		0.166	37.460	27.840	-17.698	55.158	9.593	0.027	0.000	AV
5		0.190	49.553	39.927	-14.483	64.037	9.598	0.028	0.000	QP
6		0.190	36.303	26.677	-17.734	54.037	9.598	0.028	0.000	AV
7		0.210	49.616	39.988	-13.590	63.205	9.599	0.029	0.000	QP
8		0.210	33.873	24.245	-19.333	53.205	9.599	0.029	0.000	AV
9		0.762	28.507	18.865	-27.493	56.000	9.590	0.052	0.000	QP
10		0.762	14.766	5.124	-31.234	46.000	9.590	0.052	0.000	AV
11		1.362	28.888	19.221	-27.112	56.000	9.597	0.070	0.000	QP
12		1.362	22.389	12.722	-23.611	46.000	9.597	0.070	0.000	AV

Note:

1. " * ", means this data is the worst emission level.
2. Measurement Level = Reading Level + Factor(Probe+Cable-Amp).

4. Emissions in restricted frequency bands

4.1. Test Equipment

Radiated Emission(Below 1GHz) / AC-2				
Instrument	Manufacturer	Type No.	Serial No.	Cal. Due Date
EMI Test Receiver	R&S	ESCI	100573	2018.03.28
Loop Antenna	R&S	HFH2-Z2	833799/003	2018.11.15
Bilog Antenna	Teseq GmbH	CBL6112D	27611	2018.10.15
Coaxial Cable	Huber+Suhner	SUCOFLEX 106	AC2-C	2018.03.01
Temperature/Humidity Meter	Zhichen	ZC1-2	AC2-TH	2019.01.02
Note: All equipment are calibrated with traceable calibrations. Each calibration is traceable to the national or international standards.				

Radiated Emission(Above 1GHz) / AC-5				
Instrument	Manufacturer	Type No.	Serial No.	Cal. Due Date
Spectrum Analyzer	Agilent	E4446A	MY45300103	2019.01.03
Preamplifier	Miteq	NSP1800-25	1364185	2018.05.05
Preamplifier	QuieTek	AP-040G	CHM-0906001	2018.05.05
DRG Horn	ETS-Lindgren	3117	00123988	2018.01.21
Broad-Band Horn Antenna	Schwarzbeck	BBHA9170	294	2018.11.24
Coaxial Cable	Huber+Suhner	SUCOFLEX 106	AC5-C1	2018.03.01
Coaxial Cable	Huber+Suhner	SUCOFLEX 106	AC5-C2	2018.03.01
Coaxial Cable	Huber+Suhner	SUCOFLEX 102	AC5-C3	2018.03.01
EMI Receiver	Agilent	N9038A	MY51210196	2018.06.09
Temperature/Humidity Meter	Zhichen	ZC1-2	AC5-TH	2019.01.03
Note: All equipment are calibrated with traceable calibrations. Each calibration is traceable to the national or international standards.				

4.2. Test Setup

Below 30MHz Test Setup:

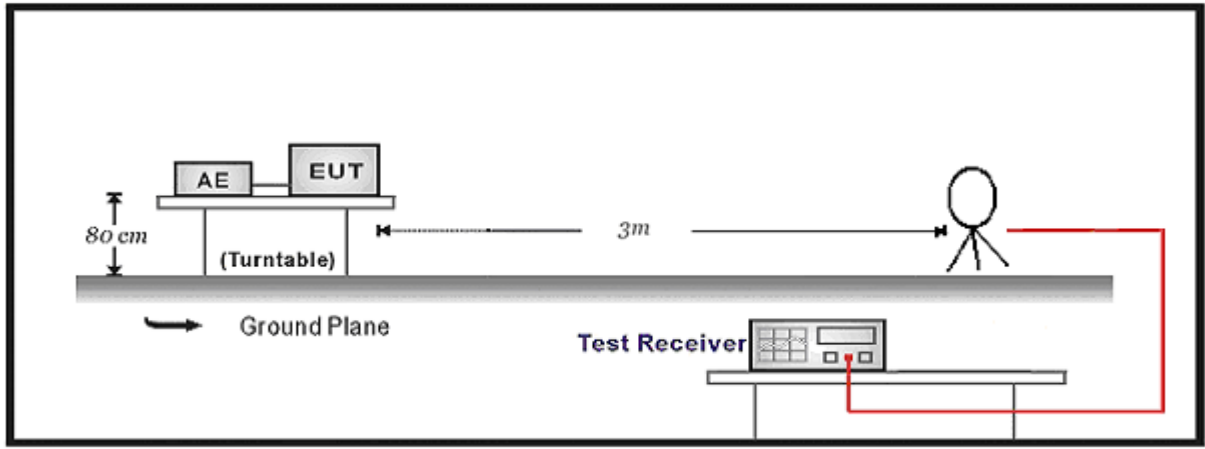

30MHz-1GHz Test Setup:

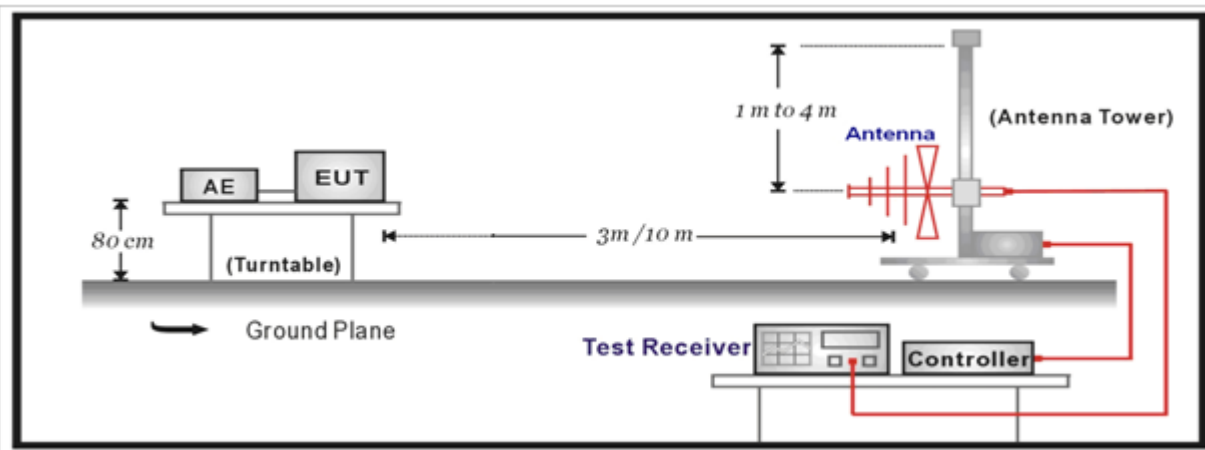

Above 1GHz Test Setup:

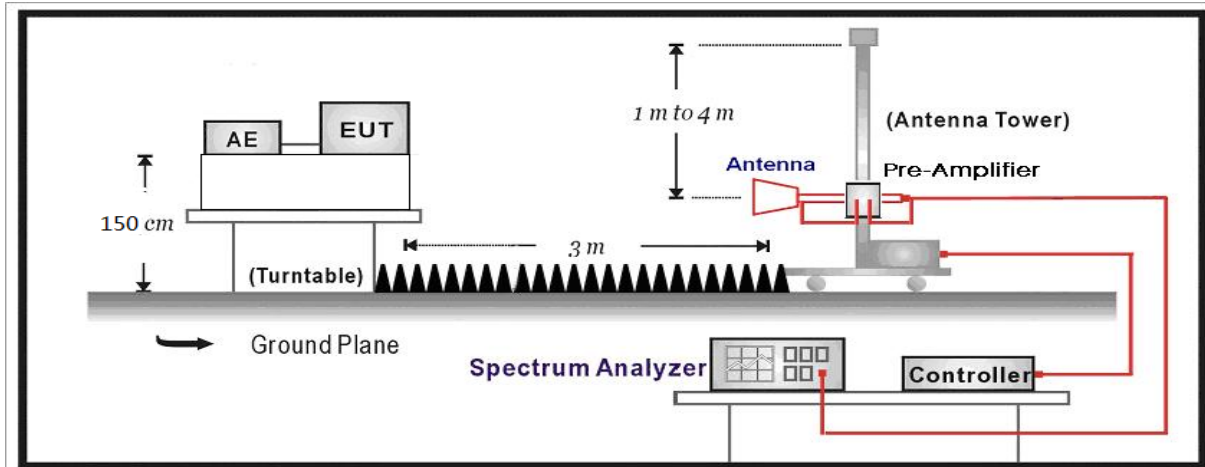

4.3. Limit

For FCC

Restricted Bands of operation			
Frequency (MHz)	Frequency (MHz)	Frequency (MHz)	Frequency (GHz)
0.090 – 0.110	16.42 – 16.423	399.9 – 410	4.5 – 5.15
0.495 – 0.505	16.69475 – 16.69525	608 – 614	5.35 – 5.46
2.1735 – 2.1905	16.80425 – 16.80475	960 – 1240	7.25 – 7.75
4.125 – 4.128	25.5 – 25.67	1300 – 1427	8.025 – 8.5
4.17725 – 4.17775	37.5 – 38.25	1435 – 1626.5	9.0 – 9.2
4.20725 – 4.20775	73 – 74.6	1645.5 – 1646.5	9.3 – 9.5
6.215 – 6.218	74.8 – 75.2	1660 – 1710	10.6 – 12.7
6.26775 – 6.26825	108 – 121.94	1718.8 – 1722.2	13.25 – 13.4
6.31175 – 6.31225	123 – 138	2200 – 2300	14.47 – 14.5
8.291 – 8.294	149.9 – 150.05	2310 – 2390	15.35 – 16.2
8.362 – 8.366	156.52475 – 156.52525	2483.5 – 2500	17.7 – 21.4
8.37625 – 8.38675	156.7 – 156.9	2690 – 2900	22.01 – 23.12
8.81425 – 8.81475	162.0125 – 167.17	3260 – 3267	23.6 – 24.0
12.29 – 12.293	167.72 – 173.2	3332 – 3339	31.2 – 31.8
12.51975 – 12.52025	240 – 285	3345.8 – 3358	36.43 – 36.5
12.57675 – 12.57725	322 – 335.4	3600 – 4400	
13.36 – 13.41			

For IC:

Restricted Bands of operation			
Frequency (MHz)	Frequency (MHz)	Frequency (MHz)	Frequency (GHz)
0.090-0.110	13.36-13.41	1645.5-1646.5	9.0-9.2
2.1735-2.1905	16.42-16.423	1660-1710	9.3-9.5
3.020-3.026	16.69475-16.69525	1718.8-1722.2	10.6-12.7
4.125-4.128	16.80425-16.80475	2200-2300	13.25-13.4
4.17725-4.17775	25.5-25.67	2310-2390	14.47-14.5
4.20725-4.20775	37.5-38.25	2655-2900	15.35-16.2
5.677-5.683	73-74.6	3260-3267	17.7-21.4
6.215-6.218	74.8-75.2	3332-3339	22.01-23.12
6.26775-6.26825	108-138	3345.8-3358	23.6-24.0
6.31175-6.31225	156.52475-156.52525	3500-4400	31.2-31.8
8.291-8.294	156.7-156.9	4500-5150	36.43-36.5
8.362-8.366	240-285	5350-5460	Above 38.6
8.37625-8.38675	322-335.4	7250-7750	
8.41425-8.41475	399.9-410	8025-8500	
12.29-12.293	608-614		
12.51975-12.52025	960-1427		
12.57675-12.57725	1435-1626.5		

Restricted Band Emissions Limit			
Frequency (MHz)	Field strength (μ V/m)	Field strength (dB μ V/m)	Measurement distance (m)
0.009 - 0.49	2400/F(kHz)	48.5 – 13.8	300 _(Note 1)
0.49 - 1.705	24000/F(kHz)	33.8 - 23	30 _(Note 1)
1.705 - 30	30	29.5	30 _(Note 1)
30 - 88	100	40	3 _(Note 2)
88 - 216	150	43.5	3 _(Note 2)
216 - 960	200	46	3 _(Note 2)
Above 960	500	54	3 _(Note 2)





Note 1: At frequencies below 30 MHz, measurements may be performed at a distance closer than that specified in the regulations; however, an attempt should be made to avoid making measurements in the near field. Pending the development of an appropriate measurement procedure for measurements performed below 30 MHz, when performing measurements at a closer distance than specified, the results shall be extrapolated to the specified distance by either making measurements at a minimum of two distances on at least one radial to determine the proper extrapolation factor or by using the square of an inverse linear distance extrapolation factor (40 dB/decade).

Note 2: At frequencies at or above 30 MHz, measurements may be performed at a distance other than what is specified provided: measurements are not made in the near field except where it can be shown that near field measurements are appropriate due to the characteristics of the device; and it can be demonstrated that the signal levels needed to be measured at the distance employed can be detected by the measurement equipment. Measurements shall not be performed at a distance greater than 30 meters unless it can be further demonstrated that measurements at a distance of 30 meters or less are impractical. When performing measurements at a distance other than that specified, the results shall be extrapolated to the specified distance using an extrapolation factor of 20 dB/decade (inverse linear-distance for field strength measurements; inverse-linear-distance-squared for power density measurements).

4.4. Test Procedure

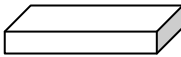
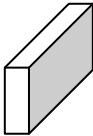
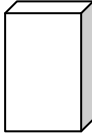
Test Method			
	References Rule	Chapter	Description
<input type="checkbox"/>	ANSI C63.10	11.11	Emissions in non-restricted frequency bands
	<input type="checkbox"/> ANSI C63.10	11.11.2	Reference level measurement
	<input type="checkbox"/> ANSI C63.10	11.11.3	Emission level measurement
<input checked="" type="checkbox"/>	ANSI C63.10	11.12	Emissions in restricted frequency bands
	<input checked="" type="checkbox"/> ANSI C63.10	11.12.1	Radiated emission measurements
	<input checked="" type="checkbox"/> ANSI C63.10	11.12.2.7	Radiated spurious emission test
	<input checked="" type="checkbox"/> ANSI C63.10	6.4	Radiated emissions from unlicensed wireless devices below 30 MHz
	<input checked="" type="checkbox"/> ANSI C63.10	6.5	Radiated emissions from unlicensed wireless devices in the frequency range of 30 MHz to 1000 MHz
	<input checked="" type="checkbox"/> ANSI C63.10	6.6	Radiated emissions from unlicensed wireless devices above 1 GHz
	<input type="checkbox"/> ANSI C63.10	11.12.2.3	Quasi-peak measurement procedure
	<input checked="" type="checkbox"/> ANSI C63.10	11.12.2.4	Peak power measurement procedure
	<input checked="" type="checkbox"/> ANSI C63.10	11.12.2.5	Average power measurement procedures
	<input type="checkbox"/> ANSI C63.10	11.12.2.5.1	Trace averaging with continuous EUT transmission at full power
	<input type="checkbox"/> ANSI C63.10	11.12.2.5.2	Trace averaging across ON and OFF times of the EUT transmissions followed by duty cycle correction
	<input checked="" type="checkbox"/> ANSI C63.10	11.12.2.5.3	Reduced VBW averaging across ON and OFF times of the EUT transmissions with max hold

4.5. EUT test Axis definition

Item	Emissions in restricted frequency bands			
Device Category	<input type="checkbox"/>	Fixed point-to-point		
	<input type="checkbox"/>	Emit multiple directional beams, simultaneously or sequentially		
	<input checked="" type="checkbox"/>	Other cases		
Test mode	Mode 1			
Test method	<input checked="" type="checkbox"/>	Radiated		
		X Axis	Y Axis	Z Axis
				
		Worst Axis <input checked="" type="checkbox"/>	Worst Axis <input type="checkbox"/>	Worst Axis <input type="checkbox"/>
	<input type="checkbox"/>	Conducted		
	<input type="checkbox"/>	Chain 0		
				
	<input type="checkbox"/>	Chain 0	Chain 1	
				
	<input type="checkbox"/>	Chain 0	Chain 1	Chain 2
				

4.6. Test Result

Test result for Alvis+Diodes:

Engineer: Karl	
Site: AC5	Time: 2017/09/27 - 10:58
Limit: FCC_Part15.209_RE(3m)	Margin: 0
Probe: FCC	Polarity: Horizontal
EUT: LED lamp	Power: AC 120V/60Hz
Note: Mode 1:Transmit at 2405MHz by zigbee	

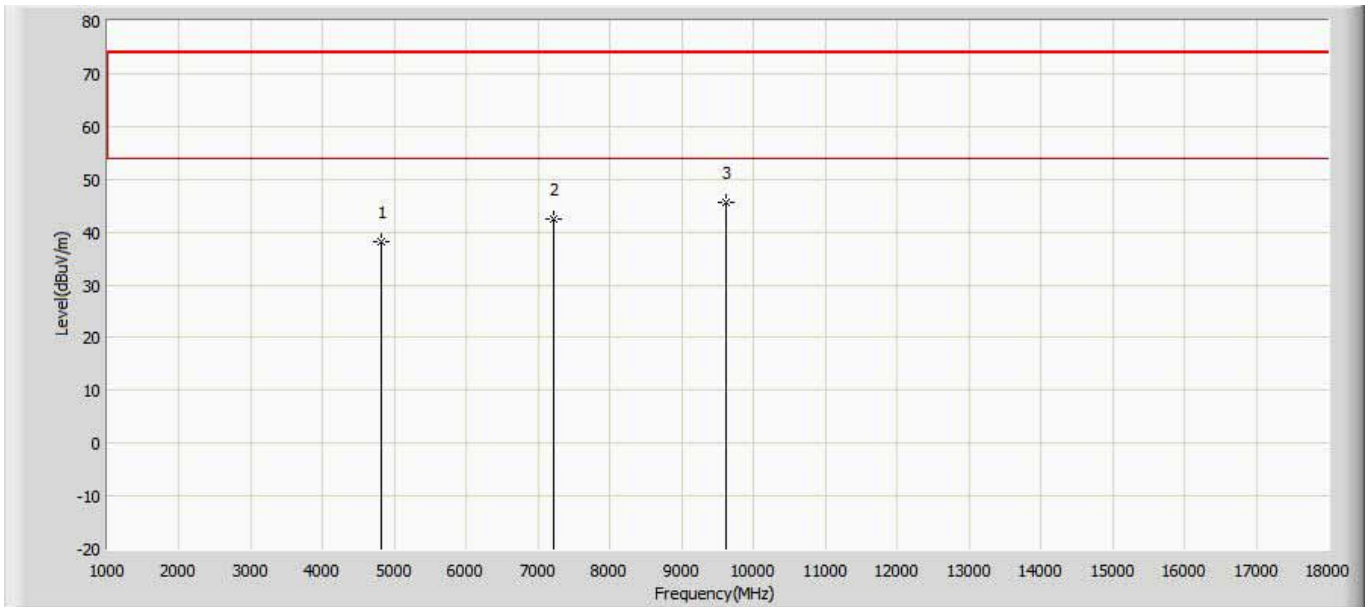

No	Mark	Frequency (MHz)	Measure Level (dBuV/m)	Reading Level (dBuV)	Over Limit (dB)	Limit (dBuV/m)	Factor (dB)	Type
1		4810.000	38.240	51.250	-35.760	74.000	-13.010	PK
2		7215.000	42.508	50.218	-31.492	74.000	-7.710	PK
3	*	9620.000	45.479	47.069	-28.521	74.000	-1.590	PK

Engineer: Karl	
Site: AC5	Time: 2017/09/27 - 10:58
Limit: FCC_Part15.209_RE(3m)	Margin: 0
Probe: FCC	Polarity: Vertical
EUT: LED lamp	Power: AC 120V/60Hz
Note: Mode 1:Transmit at 2405MHz by zigbee	

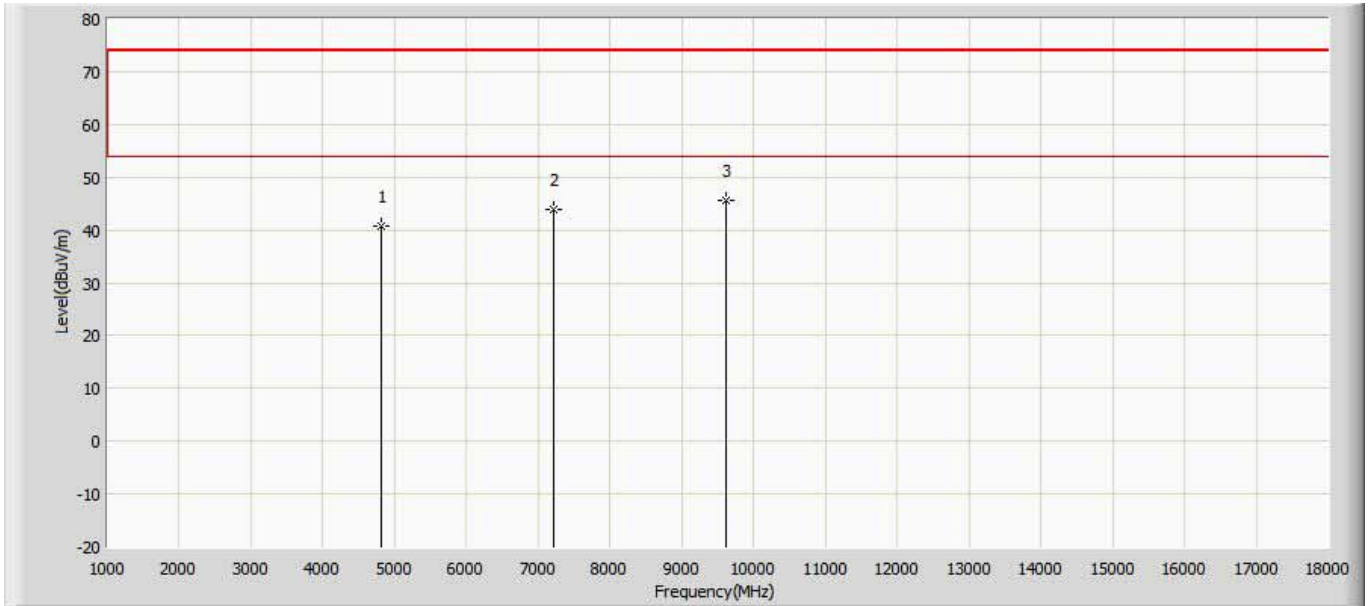

No	Mark	Frequency (MHz)	Measure Level (dBuV/m)	Reading Level (dBuV)	Over Limit (dB)	Limit (dBuV/m)	Factor (dB)	Type
1		4810.000	40.637	53.647	-33.363	74.000	-13.010	PK
2		7215.000	43.771	51.481	-30.229	74.000	-7.710	PK
3	*	9620.000	45.579	47.169	-28.421	74.000	-1.590	PK

Engineer: Karl	
Site: AC5	Time: 2017/09/27 - 10:59
Limit: FCC_Part15.209_RE(3m)	Margin: 0
Probe: FCC	Polarity: Horizontal
EUT: LED lamp	Power: AC 120V/60Hz
Note: Mode 1:Transmit at 2450MHz by zigbee	

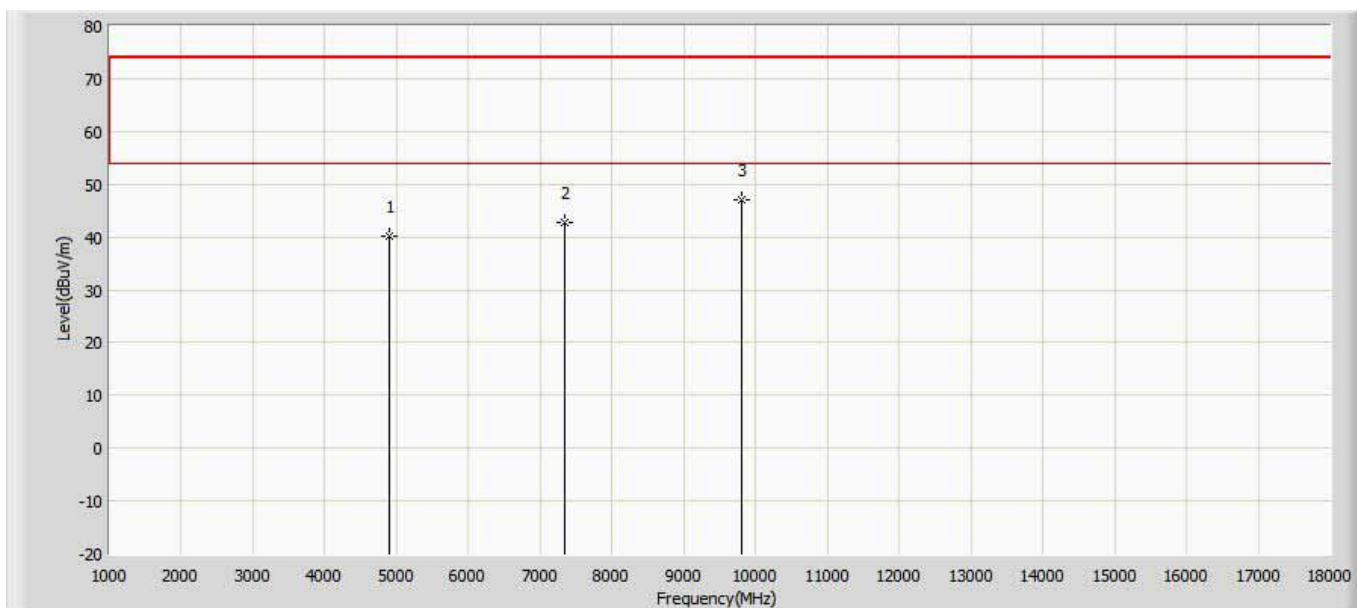

No	Mark	Frequency (MHz)	Measure Level (dBuV/m)	Reading Level (dBuV)	Over Limit (dB)	Limit (dBuV/m)	Factor (dB)	Type
1		4900.000	40.129	53.139	-33.871	74.000	-13.010	PK
2		7350.000	42.857	50.567	-31.143	74.000	-7.710	PK
3	*	9800.000	47.160	48.750	-26.840	74.000	-1.590	PK

Engineer: Karl	
Site: AC5	Time: 2017/09/27 - 10:59
Limit: FCC_Part15.209_RE(3m)	Margin: 0
Probe: FCC	Polarity: Vertical
EUT: LED lamp	Power: AC 120V/60Hz
Note: Mode 1:Transmit at 2450MHz by zigbee	

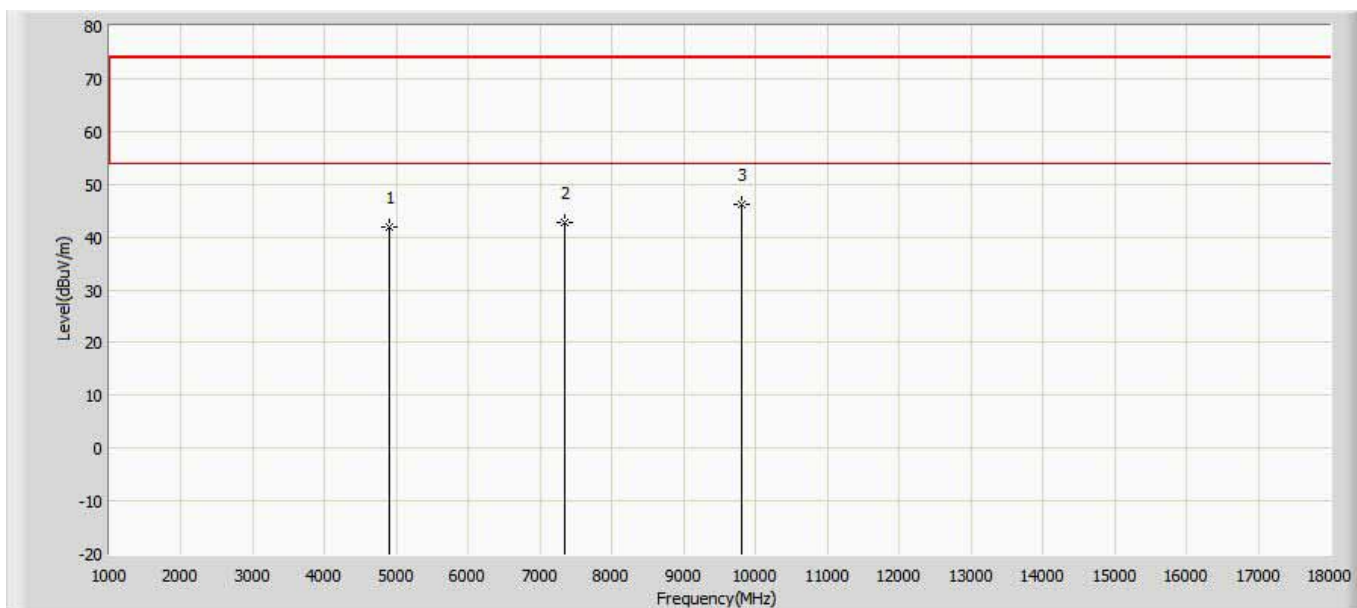

No	Mark	Frequency (MHz)	Measure Level (dBuV/m)	Reading Level (dBuV)	Over Limit (dB)	Limit (dBuV/m)	Factor (dB)	Type
1		4900.000	41.803	54.813	-32.197	74.000	-13.010	PK
2		7350.000	42.683	50.393	-31.317	74.000	-7.710	PK
3	*	9800.000	46.267	47.857	-27.733	74.000	-1.590	PK

Engineer: Karl	
Site: AC5	Time: 2017/09/27 - 11:00
Limit: FCC_Part15.209_RE(3m)	Margin: 0
Probe: FCC	Polarity: Horizontal
EUT: LED lamp	Power: AC 120V/60Hz
Note: Mode 1:Transmit at 2480MHz by zigbee	

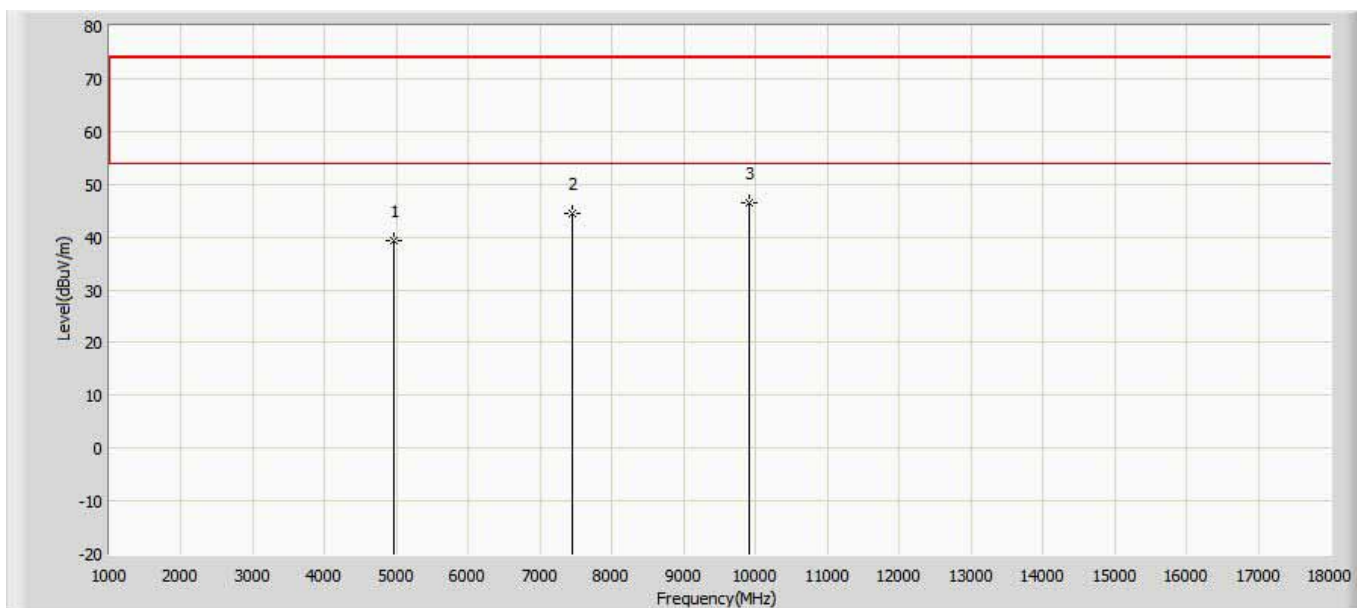

No	Mark	Frequency (MHz)	Measure Level (dBuV/m)	Reading Level (dBuV)	Over Limit (dB)	Limit (dBuV/m)	Factor (dB)	Type
1		4960.000	39.312	51.542	-34.688	74.000	-12.230	PK
2		7440.000	44.603	51.263	-29.397	74.000	-6.660	PK
3	*	9920.000	46.361	48.321	-27.639	74.000	-1.960	PK

Engineer: Karl	
Site: AC5	Time: 2017/09/27 - 11:00
Limit: FCC_Part15.209_RE(3m)	Margin: 0
Probe: FCC	Polarity: Vertical
EUT: LED lamp	Power: AC 120V/60Hz
Note: Mode 1:Transmit at 2480MHz by zigbee	

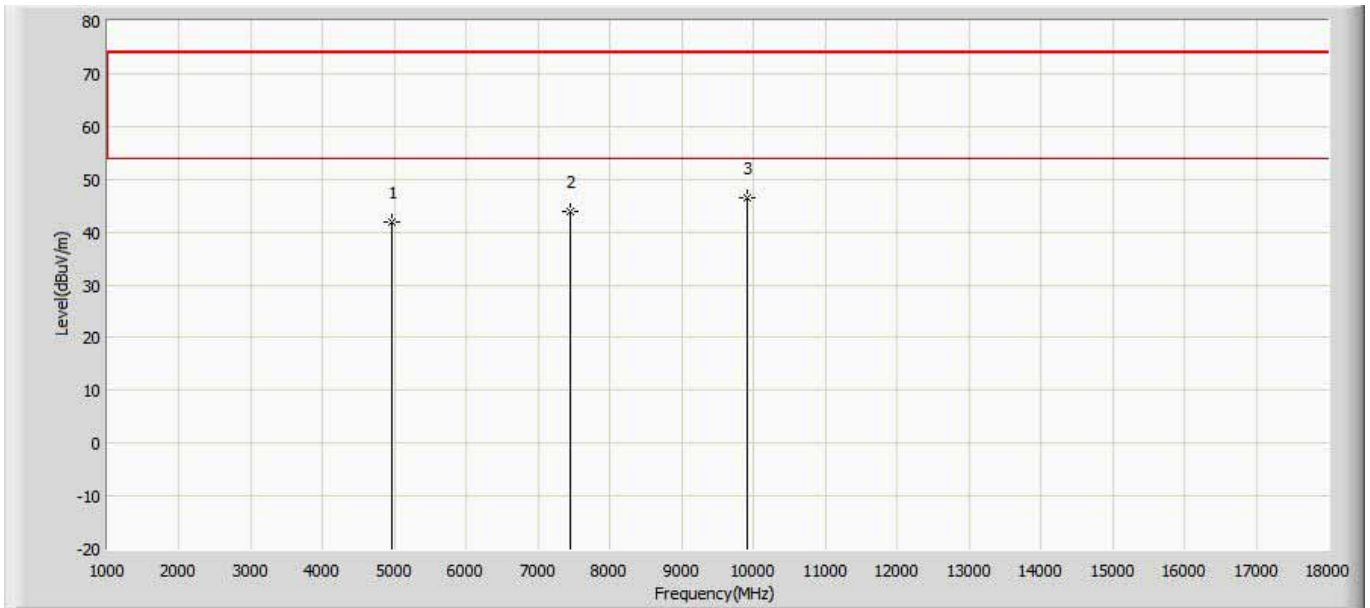

No	Mark	Frequency (MHz)	Measure Level (dBuV/m)	Reading Level (dBuV)	Over Limit (dB)	Limit (dBuV/m)	Factor (dB)	Type
1		4960.000	41.824	54.054	-32.176	74.000	-12.230	PK
2		7440.000	43.964	50.624	-30.036	74.000	-6.660	PK
3	*	9920.000	46.365	48.325	-27.635	74.000	-1.960	PK

Note:

1. Measured Level = Reading Level + Factor.
2. The test frequency range, 9kHz~30MHz, 18GHz~26GHz, both of the worst case are at least 20dB below the limits, therefore no data appear in the report.
3. This limit applies for using average detector, if the test result on peak is lower than average limit, then average measurement needn't be performed.
4. As the radiated emission was performed, so conducted emission was not tested.

Test result for Alvis+Murata:

Engineer: Allen	
Site: AC5	Time: 2017/12/17 - 10:58
Limit: FCC_Part15.209_RE(3m)	Margin: 0
Probe: FCC	Polarity: Horizontal
EUT: LED lamp	Power: AC 120V/60Hz
Note: Mode 1:Transmit at 2405MHz by zigbee	

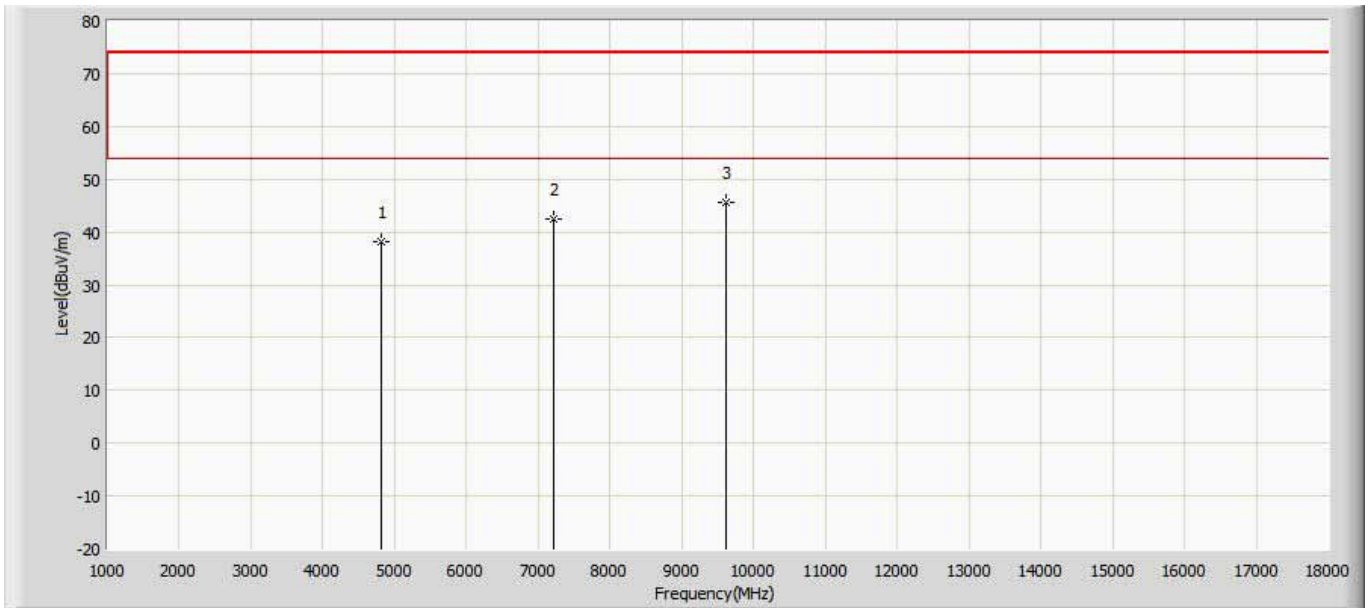

No	Mark	Frequency (MHz)	Measure Level (dBuV/m)	Reading Level (dBuV)	Over Limit (dB)	Limit (dBuV/m)	Factor (dB)	Type
1		4810.000	38.340	51.350	-35.660	74.000	-13.010	PK
2		7215.000	42.408	50.118	-31.592	74.000	-7.710	PK
3	*	9620.000	45.379	46.969	-28.621	74.000	-1.590	PK

Engineer: Allen	
Site: AC5	Time: 2017/12/17 - 10:58
Limit: FCC_Part15.209_RE(3m)	Margin: 0
Probe: FCC	Polarity: Vertical
EUT: LED lamp	Power: AC 120V/60Hz
Note: Mode 1:Transmit at 2405MHz by zigbee	

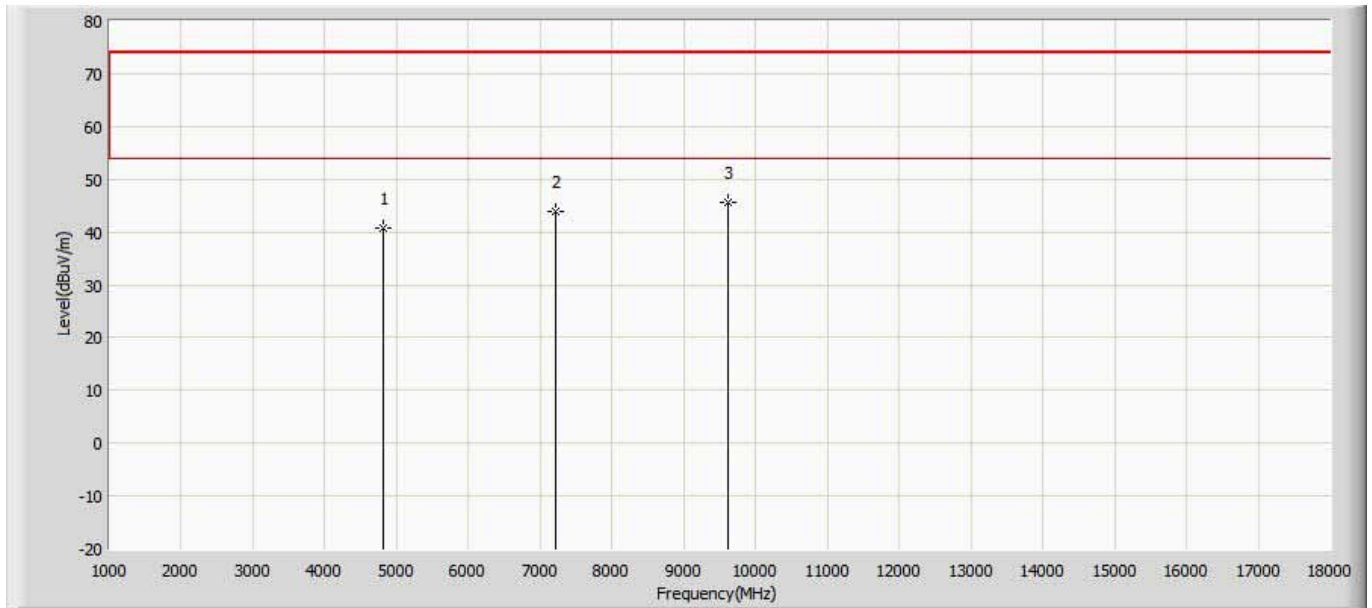

No	Mark	Frequency (MHz)	Measure Level (dBuV/m)	Reading Level (dBuV)	Over Limit (dB)	Limit (dBuV/m)	Factor (dB)	Type
1		4810.000	40.436	53.446	-33.564	74.000	-13.010	PK
2		7215.000	43.672	51.382	-30.328	74.000	-7.710	PK
3	*	9620.000	45.277	46.867	-28.723	74.000	-1.590	PK

Engineer: Allen	
Site: AC5	Time: 2017/12/17 - 10:59
Limit: FCC_Part15.209_RE(3m)	Margin: 0
Probe: FCC	Polarity: Horizontal
EUT: LED lamp	Power: AC 120V/60Hz
Note: Mode 1:Transmit at 2450MHz by zigbee	

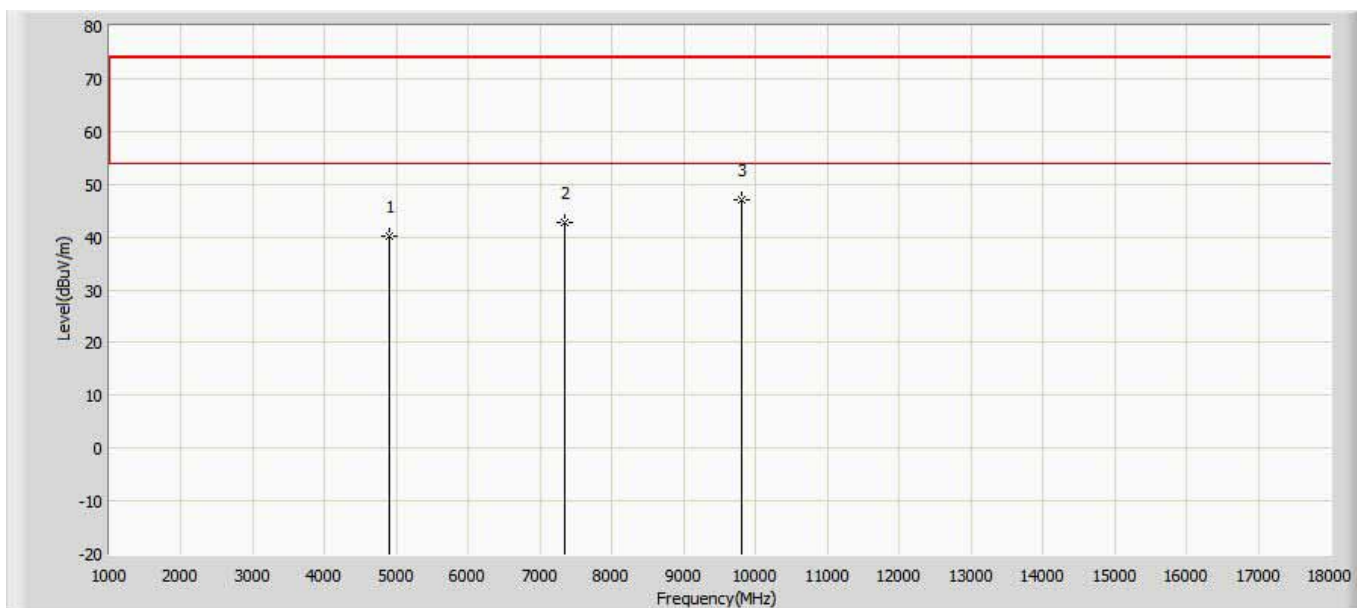

No	Mark	Frequency (MHz)	Measure Level (dBuV/m)	Reading Level (dBuV)	Over Limit (dB)	Limit (dBuV/m)	Factor (dB)	Type
1		4900.000	40.328	53.338	-33.672	74.000	-13.010	PK
2		7350.000	42.655	50.365	-31.345	74.000	-7.710	PK
3	*	9800.000	46.360	47.950	-27.640	74.000	-1.590	PK

Engineer: Allen	
Site: AC5	Time: 2017/12/17 - 10:59
Limit: FCC_Part15.209_RE(3m)	Margin: 0
Probe: FCC	Polarity: Vertical
EUT: LED lamp	Power: AC 120V/60Hz
Note: Mode 1:Transmit at 2450MHz by zigbee	

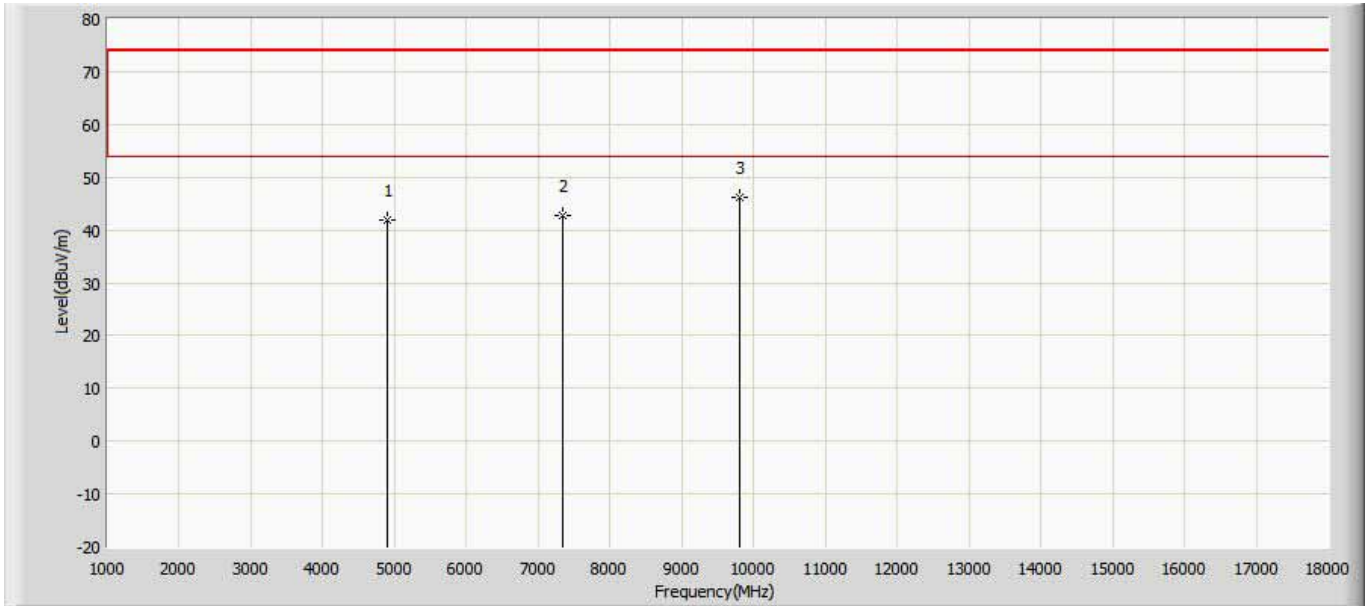

No	Mark	Frequency (MHz)	Measure Level (dBuV/m)	Reading Level (dBuV)	Over Limit (dB)	Limit (dBuV/m)	Factor (dB)	Type
1		4900.000	41.202	54.212	-32.798	74.000	-13.010	PK
2		7350.000	41.181	48.891	-32.819	74.000	-7.710	PK
3	*	9800.000	46.565	48.155	-27.435	74.000	-1.590	PK

Engineer: Allen	
Site: AC5	Time: 2017/12/17 - 11:00
Limit: FCC_Part15.209_RE(3m)	Margin: 0
Probe: FCC	Polarity: Horizontal
EUT: LED lamp	Power: AC 120V/60Hz
Note: Mode 1:Transmit at 2480MHz by zigbee	

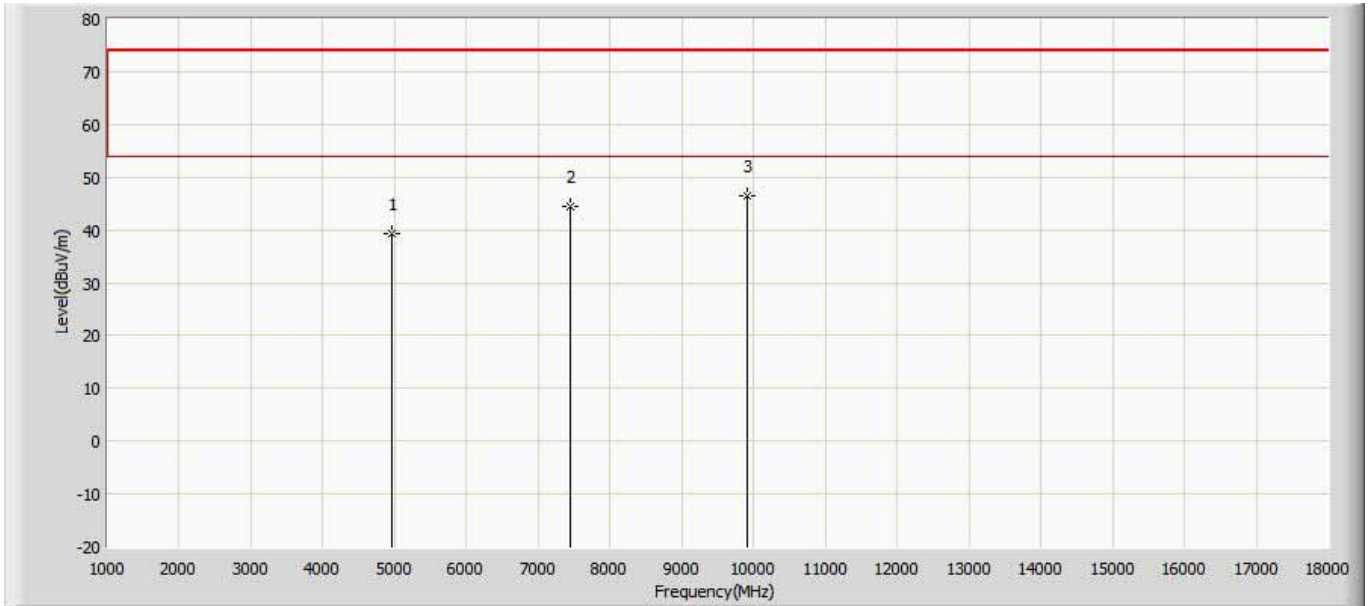

No	Mark	Frequency (MHz)	Measure Level (dBuV/m)	Reading Level (dBuV)	Over Limit (dB)	Limit (dBuV/m)	Factor (dB)	Type
1		4960.000	39.413	52.423	-34.587	74.000	-13.010	PK
2		7440.000	44.504	52.214	-29.496	74.000	-7.710	PK
3	*	9920.000	46.263	47.853	-27.737	74.000	-1.590	PK

Engineer: Allen	
Site: AC5	Time: 2017/12/17 - 11:00
Limit: FCC_Part15.209_RE(3m)	Margin: 0
Probe: FCC	Polarity: Vertical
EUT: LED lamp	Power: AC 120V/60Hz
Note: Mode 1:Transmit at 2480MHz by zigbee	

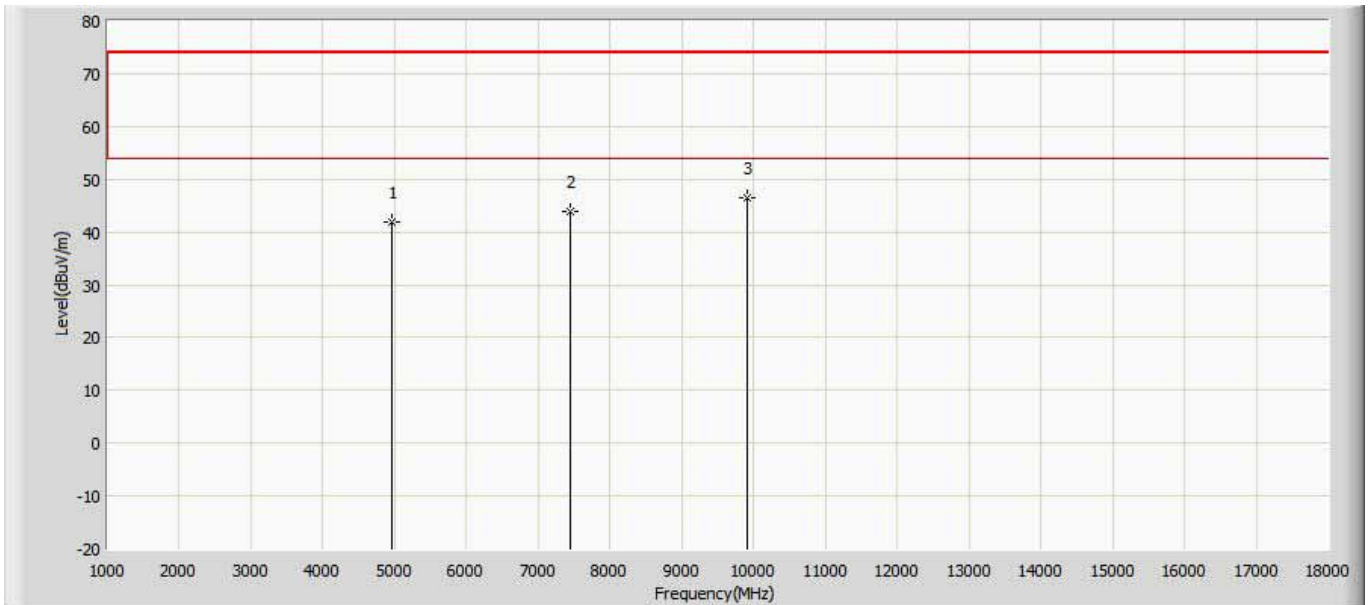

No	Mark	Frequency (MHz)	Measure Level (dBuV/m)	Reading Level (dBuV)	Over Limit (dB)	Limit (dBuV/m)	Factor (dB)	Type
1		4960.000	41.625	54.635	-32.375	74.000	-13.010	PK
2		7440.000	43.866	51.576	-30.134	74.000	-7.710	PK
3	*	9920.000	46.563	48.153	-27.437	74.000	-1.590	PK

Note:

1. Measured Level = Reading Level + Factor.
2. The test frequency range, 9kHz~30MHz, 18GHz~26GHz, both of the worst case are at least 20dB below the limits, therefore no data appear in the report.
3. This limit applies for using average detector, if the test result on peak is lower than average limit, then average measurement needn't be performed.
4. As the radiated emission was performed, so conducted emission was not tested.

The worst case of Radiated Emission below 1GHz:

Test result for Alvis+Diodes:

Engineer: Lei-wan	
Site: AC2	Time: 2017/09/04 - 13:44
Limit: FCC_Part15.109_RE(3m)_ClassB	Margin: 0
Probe: AC2_3M(30-1000M)	Polarity: Horizontal
EUT: LED lamp	Power: AC 120V/60Hz
Note: Mode 1:Transmit at 2450MHz by zigbee	

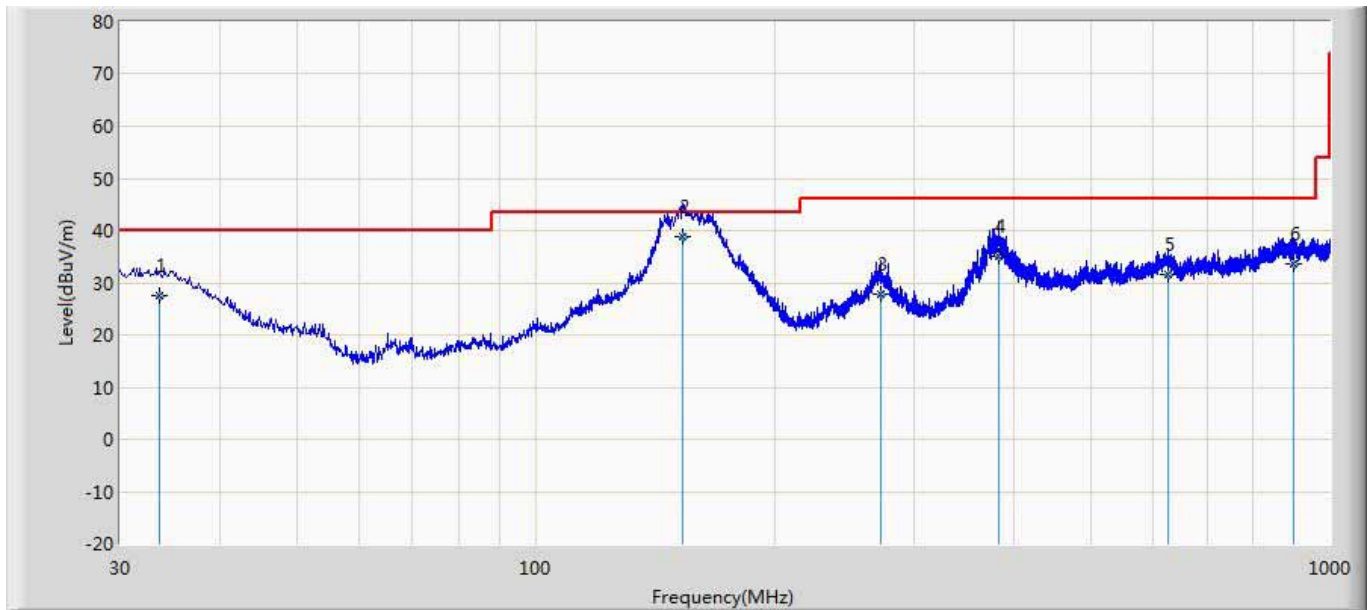

No	Mark	Frequency (MHz)	Measure Level (dBuV/m)	Reading Level (dBuV)	Over Limit (dB)	Limit (dBuV/m)	Probe (dB/m)	Cable (dB)	Amp (dB)	Ant Pos (cm)	Table Pos (deg)	Type
1		33.553	27.466	0.102	-12.534	40.000	20.707	6.657	0.000	200	96	QP
2	*	153.101	38.753	21.700	-4.747	43.500	9.850	7.203	0.000	200	25	QP
3		272.405	27.894	8.632	-18.106	46.000	11.669	7.593	0.000	200	106	QP
4		383.632	35.109	10.328	-10.891	46.000	16.887	7.895	0.000	200	151	QP
5		626.553	31.564	0.965	-14.436	46.000	22.026	8.573	0.000	200	85	QP
6		901.452	33.565	0.325	-12.435	46.000	23.987	9.253	0.000	200	127	QP

Note:

1. All Readings below 1GHz are Quasi-Peak, above are performed with peak and/or average measurements as necessary.
2. " * ", means this data is the worst emission level.
3. Measurement Level = Reading Level + Factor(Probe+Cable-Amp).

Engineer: Lei-wan	
Site: AC2	Time: 2017/09/04 - 13:47
Limit: FCC_Part15.109_RE(3m)_ClassB	Margin: 0
Probe: AC2_3M(30-1000M)	Polarity: Vertical
EUT: LED lamp	Power: AC 120V/60Hz
Note: Mode 1:Transmit at 2450MHz by zigbee	

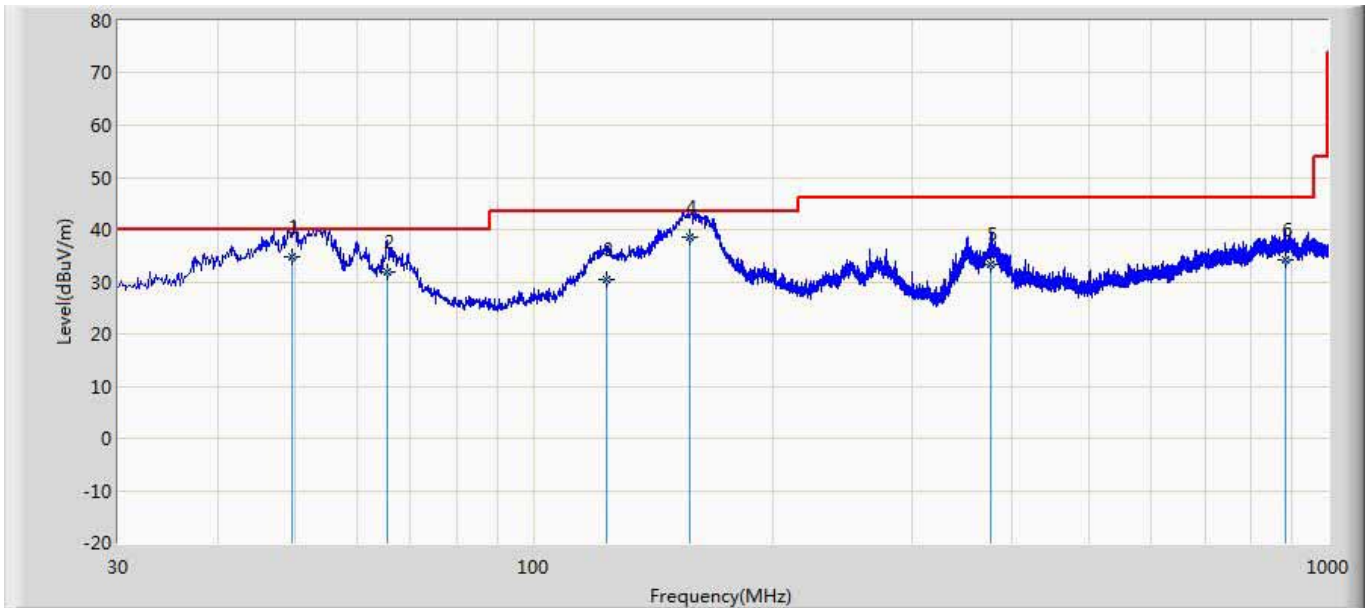

No	Mark	Frequency (MHz)	Measure Level (dBuV/m)	Reading Level (dBuV)	Over Limit (dB)	Limit (dBuV/m)	Probe (dB/m)	Cable (dB)	Amp (dB)	Ant Pos (cm)	Table Pos (deg)	Type
1		49.749	34.798	15.300	-5.202	40.000	12.942	6.555	0.000	100	338	QP
2		65.435	31.862	15.873	-8.138	40.000	9.291	6.698	0.000	100	261	QP
3		123.651	30.565	9.963	-12.935	43.500	13.573	7.029	0.000	100	125	QP
4	*	157.099	38.448	19.800	-5.052	43.500	11.418	7.230	0.000	100	360	QP
5		376.356	33.458	9.871	-12.542	46.000	15.716	7.871	0.000	100	156	QP
6		884.215	34.062	0.215	-11.938	46.000	24.635	9.212	0.000	100	284	QP

Note:

1. All Readings below 1GHz are Quasi-Peak, above are performed with peak and/or average measurements as necessary.
2. " * ", means this data is the worst emission level.
3. Measurement Level = Reading Level + Factor(Probe+Cable-Amp).

Test result for Alvis+Murata:

Engineer: Lucas	
Site: AC5	Time: 2017/09/08
Limit: FCC_Part15.109_RE(3m)_ClassB	Margin: 0
Probe: Horn_3117_00167055(1-18GHz)	Polarity: Horizontal
EUT: LED Lamp	Power: AC 120V/60Hz
Note: Mode 1:Transmit at 2450MHz by zigbee	

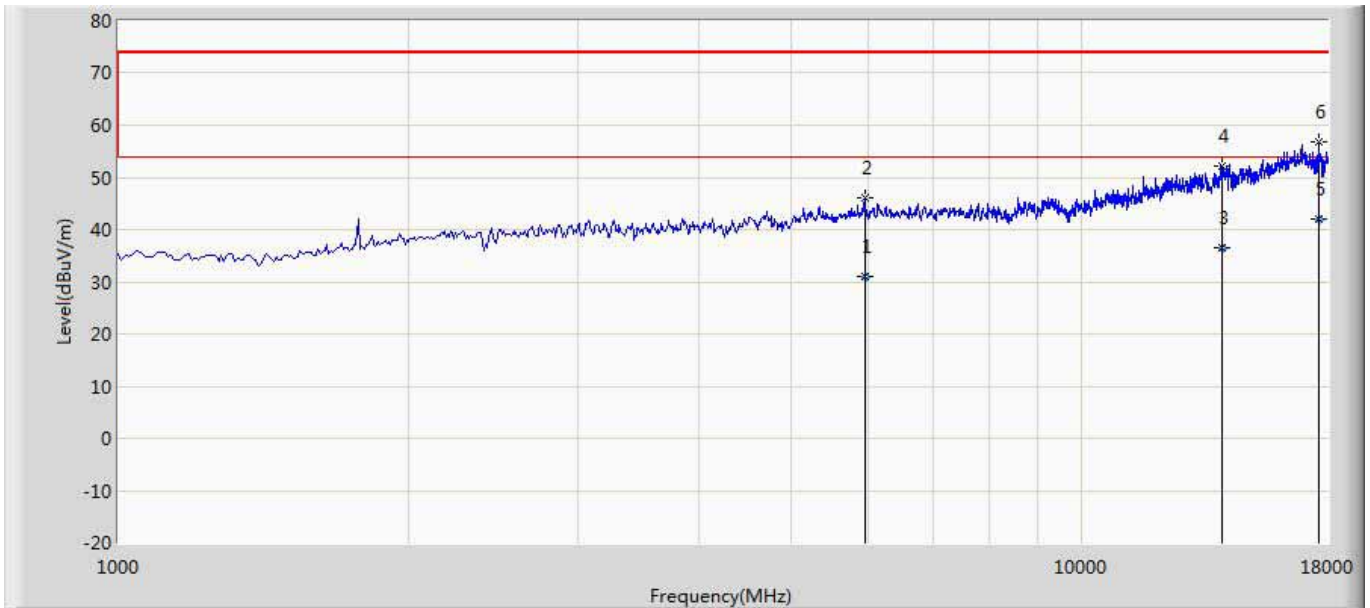

No	Mark	Frequency (MHz)	Measure Level (dBuV/m)	Reading Level (dBuV)	Over Limit (dB)	Limit (dBuV/m)	Probe (dB/m)	Cable (dB)	Amp (dB)	Ant Pos (cm)	Table Pos (deg)	Type
1		5954.362	31.069	27.362	-22.931	54.000	35.136	7.491	38.920	200	146	AV
2		5955.500	46.190	42.504	-27.810	74.000	35.138	7.473	38.925	200	146	PK
3		13995.321	36.641	20.313	-17.359	54.000	39.101	13.749	36.522	200	147	AV
4		13996.500	52.282	35.898	-21.718	74.000	39.102	13.768	36.485	200	147	PK
5	*	17624.332	41.982	20.332	-12.018	54.000	40.949	16.882	36.182	200	31	AV
6		17626.000	56.907	34.834	-17.093	74.000	40.950	17.243	36.120	200	31	PK

Note:

1. " * ", means this data is the worst emission level.
2. Measurement Level = Reading Level + Factor(Probe+Cable-Amp).

Engineer: Lucas	
Site: AC5	Time: 2017/09/08
Limit: FCC_Part15.109_RE(3m)_ClassB	Margin: 0
Probe: Horn_3117_00167055(1-18GHz)	Polarity: Vertical
EUT: LED Lamp	Power: AC 120V/60Hz
Note: Mode 1: Transmit at 2450MHz by zigbee	

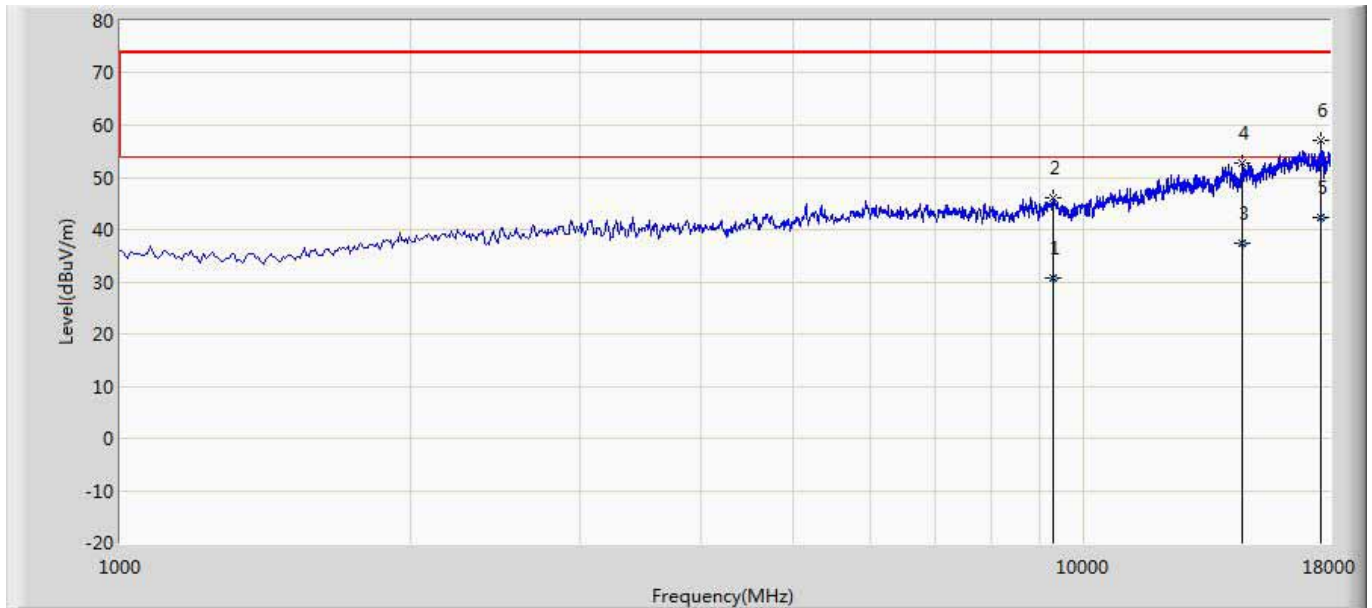

No	Mark	Frequency (MHz)	Measure Level (dBuV/m)	Reading Level (dBuV)	Over Limit (dB)	Limit (dBuV/m)	Probe (dB/m)	Cable (dB)	Amp (dB)	Ant Pos (cm)	Table Pos (deg)	Type
1		9278.322	30.592	24.333	-23.408	54.000	36.467	8.715	38.923	100	196	AV
2		9279.000	46.185	39.890	-27.815	74.000	36.467	8.728	38.900	100	196	PK
3		14606.327	37.403	21.332	-16.597	54.000	39.664	13.319	36.912	200	173	AV
4		14608.500	52.640	36.378	-21.360	74.000	39.665	13.472	36.875	200	173	PK
5	*	17625.332	42.236	20.333	-11.764	54.000	40.950	17.098	36.145	100	123	AV
6		17626.000	57.120	35.047	-16.880	74.000	40.950	17.243	36.120	100	123	PK

Note:

1. " * ", means this data is the worst emission level.
2. Measurement Level = Reading Level + Factor(Probe+Cable-Amp).

5. Emissions in non-restricted frequency bands

5.1. Test Equipment

Emissions in non-restricted frequency bands / TR-8					
Instrument	Manufacturer	Type No.	Serial No.	Cal. Date	Cal. Due Date
Spectrum Analyzer	Agilent	N9010A	MY48030494	2017.02.04	2018.02.03
EXA Spectrum Analyzer	Keysight	N9010A	MY55370495	2017.04.09	2018.04.08
MXA Signal Analyzer	Keysight	N9020A	MY56060147	2017.04.09	2018.04.08
Temperature/Humidity Meter	zhichen	ZC1-2	TR8-TH	2017.04.10	2018.04.09

Note: All equipment are calibrated with traceable calibrations. Each calibration is traceable to the national or international standards.

5.2. Test Setup

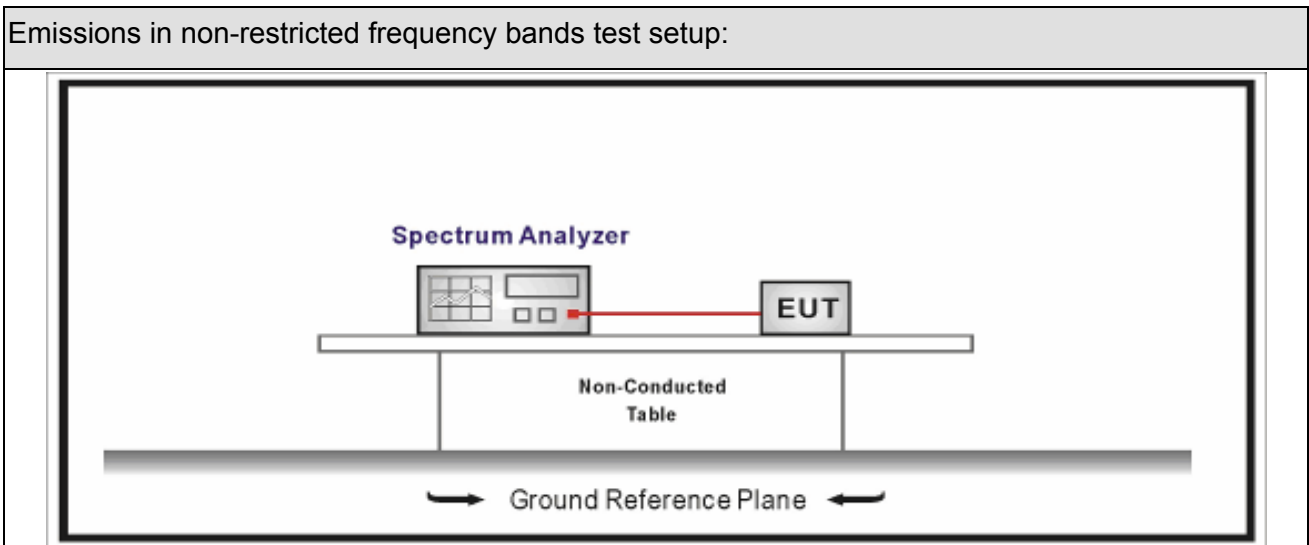





5.3. Limit

Un-Restricted Band Emissions Limit	
RF Output power (Detection methods)	Limit(dB)
RF Output power(Average detector)	30c(Note1)
RF Output power(PK detector)	20c(Note2)
<p>Note 1: If maximum conducted (average) output power was used to demonstrate compliance as described in 9.2, then the peak power in any 100 kHz bandwidth outside of the authorized frequency band shall be attenuated by at least 30 dB relative to the maximum in-band peak PSD level in 100 kHz (i.e., 30 dBc).</p> <p>Note 2: If the maximum peak conducted output power procedure was used, then the peak output power measured in any 100 kHz bandwidth outside of the authorized frequency band shall be attenuated by at least 20 dB relative to the maximum in-band peak PSD level in 100 kHz (i.e., 20 dBc).</p>	

5.4. Test Procedure

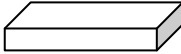
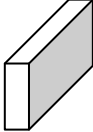
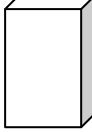
Test Method			
	References Rule	Chapter	Description
<input checked="" type="checkbox"/>	ANSI C63.10	11.11	Emissions in non-restricted frequency bands
	<input checked="" type="checkbox"/> ANSI C63.10	11.11.2	Reference level measurement
	<input checked="" type="checkbox"/> ANSI C63.10	11.11.3	Emission level measurement
<input type="checkbox"/>	ANSI C63.10	11.12	Emissions in restricted frequency bands
	<input type="checkbox"/> ANSI C63.10	11.12.1	Radiated emission measurements
	<input type="checkbox"/> ANSI C63.10	11.12.2.7	Radiated spurious emission test
<input type="checkbox"/>	ANSI C63.10	6.4	Radiated emissions from unlicensed wireless devices below 30 MHz
<input type="checkbox"/>	ANSI C63.10	6.5	Radiated emissions from unlicensed wireless devices in the frequency range of 30 MHz to 1000 MHz
<input type="checkbox"/>	ANSI C63.10	6.6	Radiated emissions from unlicensed wireless devices above 1 GHz
	<input checked="" type="checkbox"/> ANSI C63.10	11.12.2	Antenna-port conducted measurements
	<input type="checkbox"/> ANSI C63.10	11.12.2.3	Quasi-peak measurement procedure
	<input checked="" type="checkbox"/> ANSI C63.10	11.12.2.4	Peak power measurement procedure
	<input type="checkbox"/> ANSI C63.10	11.12.2.5	Average power measurement procedures
	<input type="checkbox"/> ANSI C63.10	11.12.2.5.1	Trace averaging with continuous EUT transmission at full power
	<input type="checkbox"/> ANSI C63.10	11.12.2.5.2	Trace averaging across ON and OFF times of the EUT transmissions followed by duty cycle correction
	<input type="checkbox"/> ANSI C63.10	11.12.2.5.3	Reduced VBW averaging across ON and OFF times of the EUT transmissions with max hold

5.5. EUT test Axis definition

Item	Emissions in non-restricted frequency bands			
Device Category	<input type="checkbox"/>	Fixed point-to-point		
	<input type="checkbox"/>	Emit multiple directional beams, simultaneously or sequentially		
	<input checked="" type="checkbox"/>	Other cases		
Test mode	Mode 1			
Test method	<input type="checkbox"/>	Radiated		
		X Axis	Y Axis	Z Axis
				
		Worst Axis <input type="checkbox"/>	Worst Axis <input type="checkbox"/>	Worst Axis <input type="checkbox"/>
	<input checked="" type="checkbox"/>	Conducted		
	<input checked="" type="checkbox"/>	Chain 0		
				
	<input type="checkbox"/>	Chain 0	Chain 1	
				
	<input type="checkbox"/>	Chain 0	Chain 1	Chain 2
				

5.6. Test Result

Product Name	: LED lamp	Power	: AC 120V/60Hz
Test Mode	: Mode 1	Test Site	: TR-8
Test Date	: 2017.09.15	Test engineer	: Tommy

Mode	Channel	Test Frequency (MHz)	In-Band PSD[a] (dBm/100kHz)	Frequency (MHz)	Out-Band PSD[b] (dBm/100kHz)	[a]-[b] (dB)	Limit (dB)	Result
1	11	2405	-0.434	2400.00	-56.540	56.106	>20	Pass
1	26	2480	-1.955	2500.00	-71.524	69.569	>20	Pass

Note: The worst case of Emissions in non-restricted frequency bands as below:

Mode 1 CH11 (2405MHz)

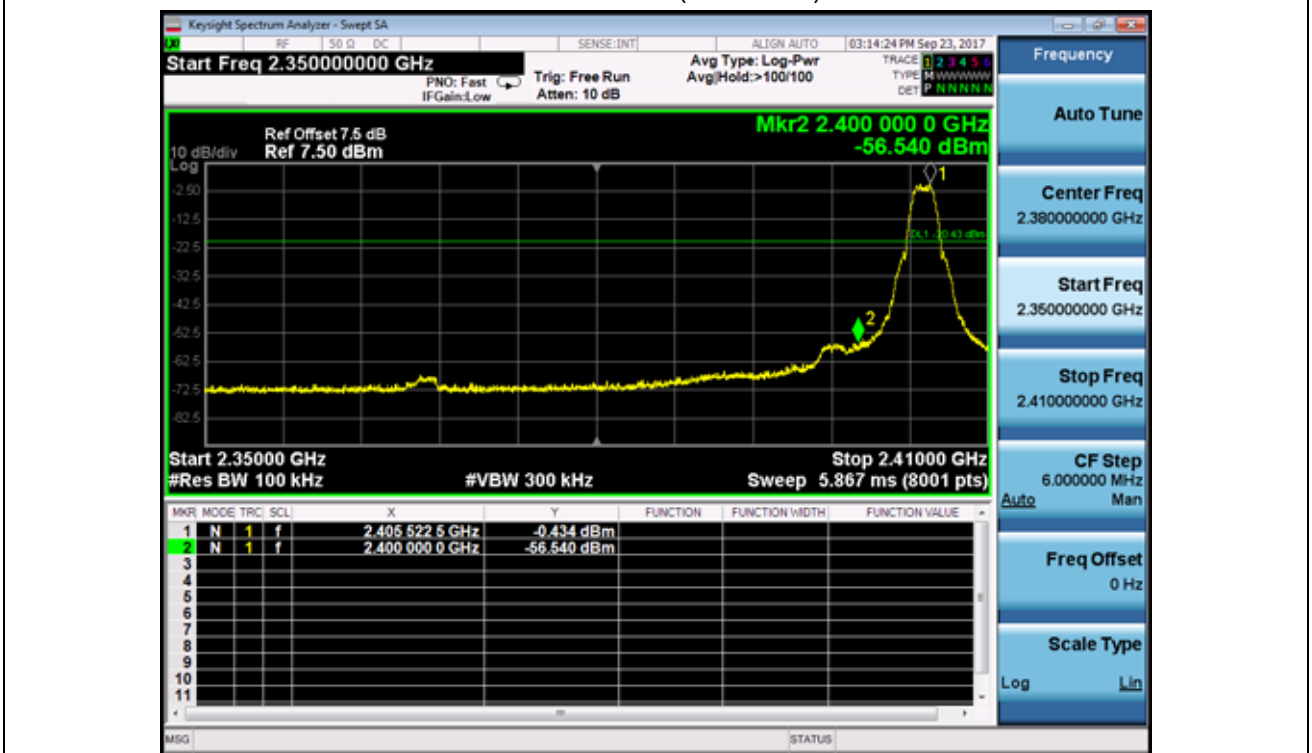

6. Radiated Emission Band Edge

6.1. Test Equipment

Radiated Emission(Above 1GHz) / AC-5					
Instrument	Manufacturer	Type No.	Serial No.	Cal. Date	Cal. Due Date
EMI Receiver	Agilent	N9038A	MY51210196	2017.07.16	2018.07.15
Pre-Amplifier	Miteq	NSP1800-25	1364185	2017.05.03	2018.05.02
DRG Horn Antenna	ETS-Lindgren	3117	00167055	2017.07.12	2018.07.11
Broad-Band Horn Antenna	Schwarzbeck	BBHA9170	294	2017.09.18	2018.09.17
Coaxial Cable	Huber+Suhner	SUCOFLEX 106	AC5-C1	2017.02.28	2018.02.27
Coaxial Cable	Huber+Suhner	SUCOFLEX 106	AC5-C2	2017.02.28	2018.02.27
Temperature/Humidity Meter	Zhichen	ZC1-2	AC5-TH	2017.01.05	2019.01.04

6.2. Test Setup

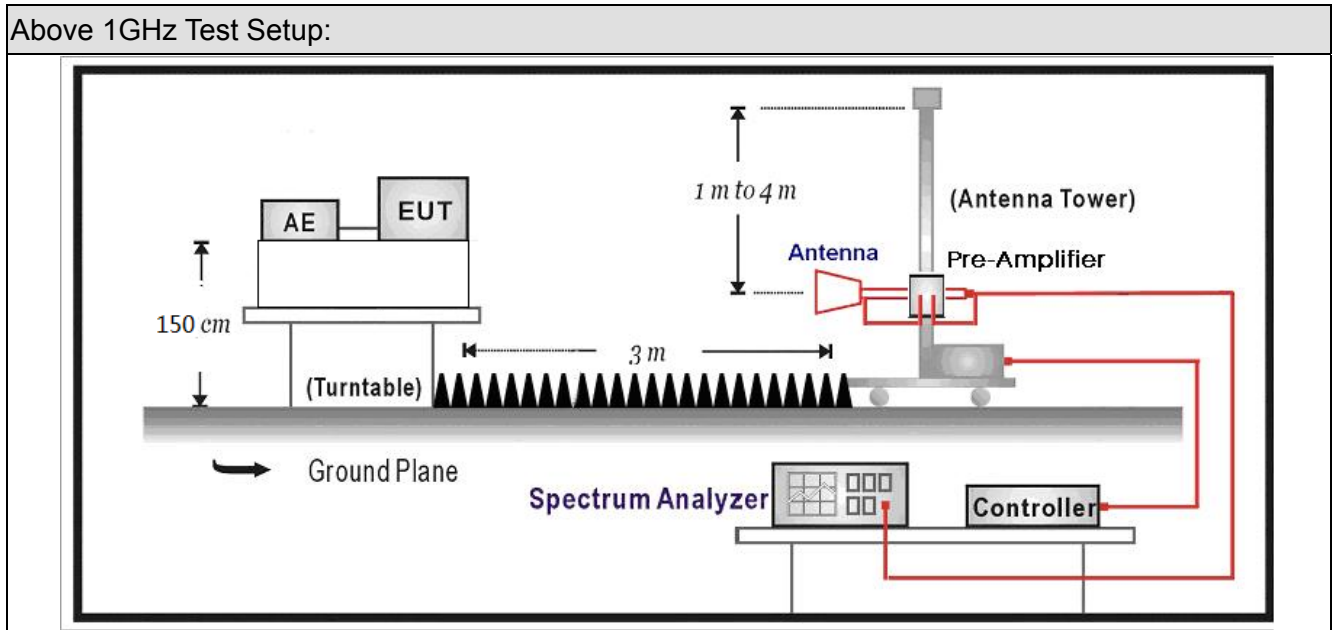

6.3. Limit





Band edge Limit				
Frequency bands (MHz)	Detector	Limit (dB μ V/m)	RBW (MHz)	Distance (m)
2310-2390	PK	74	1	3
2483.5-2500	AV	54	1	3

Note: The field strength of emissions appearing within these frequency bands shall not exceed the limits.

6.4. Test Procedure

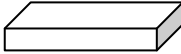
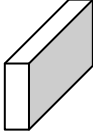
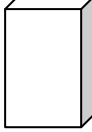
Test Method				
	References Rule		Chapter	Description
<input checked="" type="checkbox"/>	ANSI C63.10		6.10	Band-edge testing
	<input checked="" type="checkbox"/>	ANSI C63.10	6.10.5	Restricted-band band-edge measurements
	<input type="checkbox"/>	ANSI C63.10	6.10.6	Marker-delta method
<input checked="" type="checkbox"/>	ANSI C63.10		11.12	Emissions in restricted frequency bands
	<input checked="" type="checkbox"/>	ANSI C63.10	11.12.1	Radiated emission measurements
	<input checked="" type="checkbox"/>	ANSI C63.10	11.12.2.7	Radiated spurious emission test
<input type="checkbox"/>	ANSI C63.10		6.4	Radiated emissions from unlicensed wireless devices below 30 MHz
<input type="checkbox"/>	ANSI C63.10		6.5	Radiated emissions from unlicensed wireless devices in the frequency range of 30 MHz to 1000 MHz
<input checked="" type="checkbox"/>	ANSI C63.10		6.6	Radiated emissions from unlicensed wireless devices above 1 GHz
	<input type="checkbox"/>	ANSI C63.10	11.12.2.3	Quasi-peak measurement procedure
	<input checked="" type="checkbox"/>	ANSI C63.10	11.12.2.4	Peak power measurement procedure
	<input checked="" type="checkbox"/>	ANSI C63.10	11.12.2.5	Average power measurement procedures
	<input type="checkbox"/>	ANSI C63.10	11.12.2.5.1	Trace averaging with continuous EUT transmission at full power
	<input type="checkbox"/>	ANSI C63.10	11.12.2.5.2	Trace averaging across ON and OFF times of the EUT transmissions followed by duty cycle correction
	<input checked="" type="checkbox"/>	ANSI C63.10	11.12.2.5.3	Reduced VBW averaging across ON and OFF times of the EUT transmissions with max hold

6.5. EUT test definition

Item	Radiated Emission Band Edge			
Device Category	<input type="checkbox"/>	Fixed point-to-point		
	<input type="checkbox"/>	Emit multiple directional beams, simultaneously or sequentially		
	<input checked="" type="checkbox"/>	Other cases		
Test mode	Mode 1			
Test method	<input checked="" type="checkbox"/>	Radiated		
		X Axis	Y Axis	Z Axis
				
		Worst Axis <input checked="" type="checkbox"/>	Worst Axis <input type="checkbox"/>	Worst Axis <input type="checkbox"/>
	<input type="checkbox"/>	Conducted		
	<input type="checkbox"/>	Chain 0		
				
	<input type="checkbox"/>	Chain 0	Chain 1	
				
	<input type="checkbox"/>	Chain 0	Chain 1	Chain 2
				

6.6. Duty Cycle

Test Mode	Tx On (ms)	Tx Off (ms)	Reduced VBW (kHz)	Tx On + Tx Off (ms)	Duty Cycle
Zigbee	-	-	10Hz	-	100%

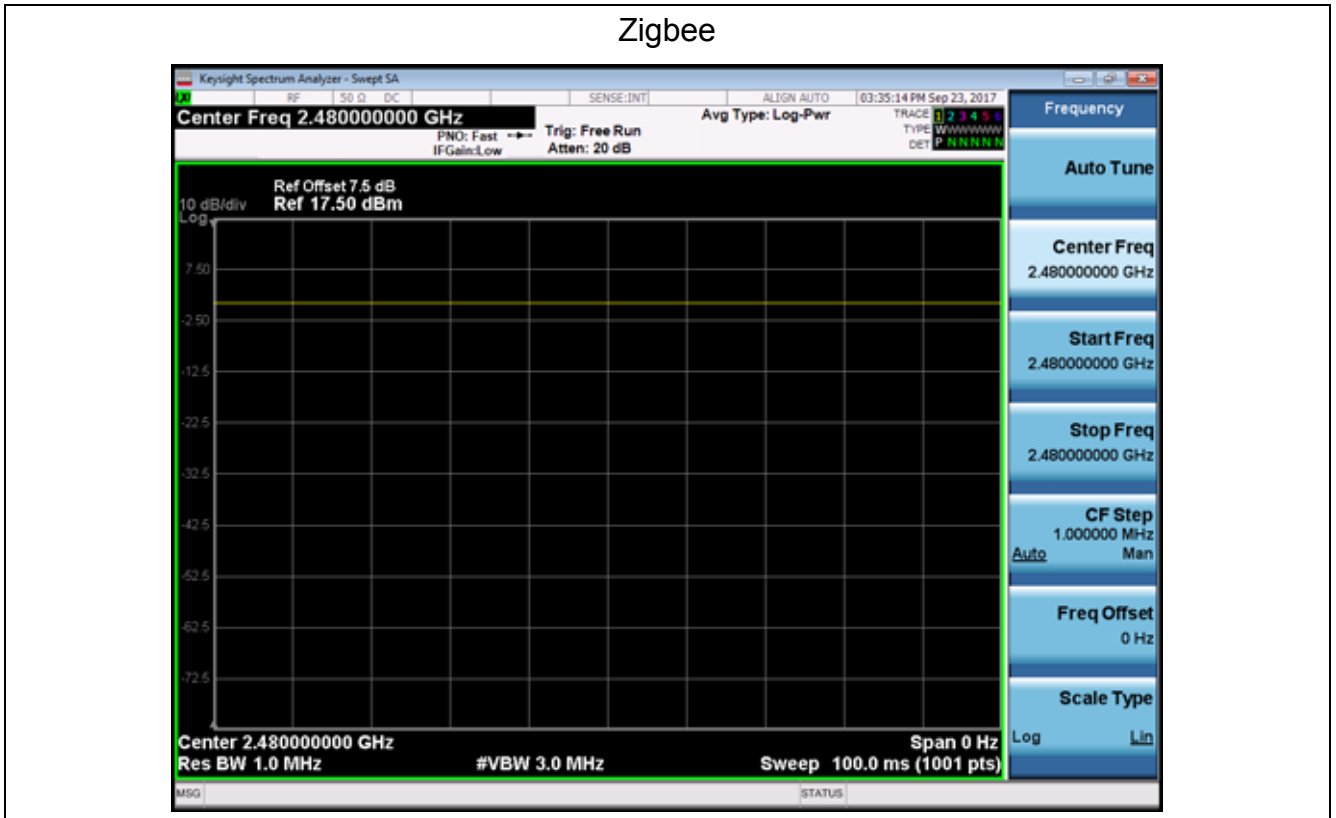

6.7 Test Result

Test result for Alvis+Diodes:

Engineer: Karl	
Site: AC5	Time: 2017/09/25 - 13:59
Limit: FCC_Part15.209_RE(3m)	Margin: 0
Probe: FCC	Polarity: Horizontal
EUT: LED lamp	Power: AC 120V/60Hz
Note: Mode 1:Transmit at 2405MHz by zigbee	

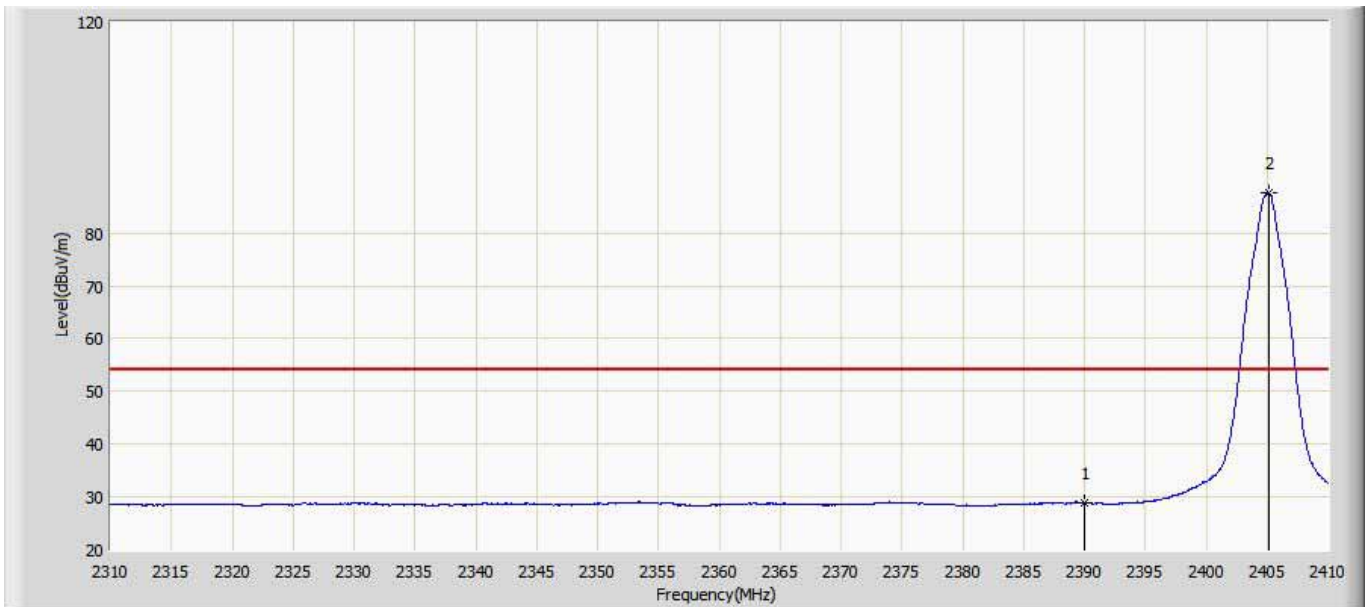

No	Mark	Frequency (MHz)	Measure Level (dBuV/m)	Reading Level (dBuV)	Over Limit (dB)	Limit (dBuV/m)	Factor (dB)	Type
1		2390.000	28.909	-0.139	-25.091	54.000	29.048	AV
2	*	2405.100	87.744	58.817	N/A	N/A	28.927	AV

Engineer: Karl	
Site: AC5	Time: 2017/09/25 - 15:06
Limit: FCC_Part15.209_RE(3m)	Margin: 0
Probe: FCC	Polarity: Horizontal
EUT: LED lamp	Power: AC 120V/60Hz
Note: Mode 1:Transmit at 2405MHz by zigbee	

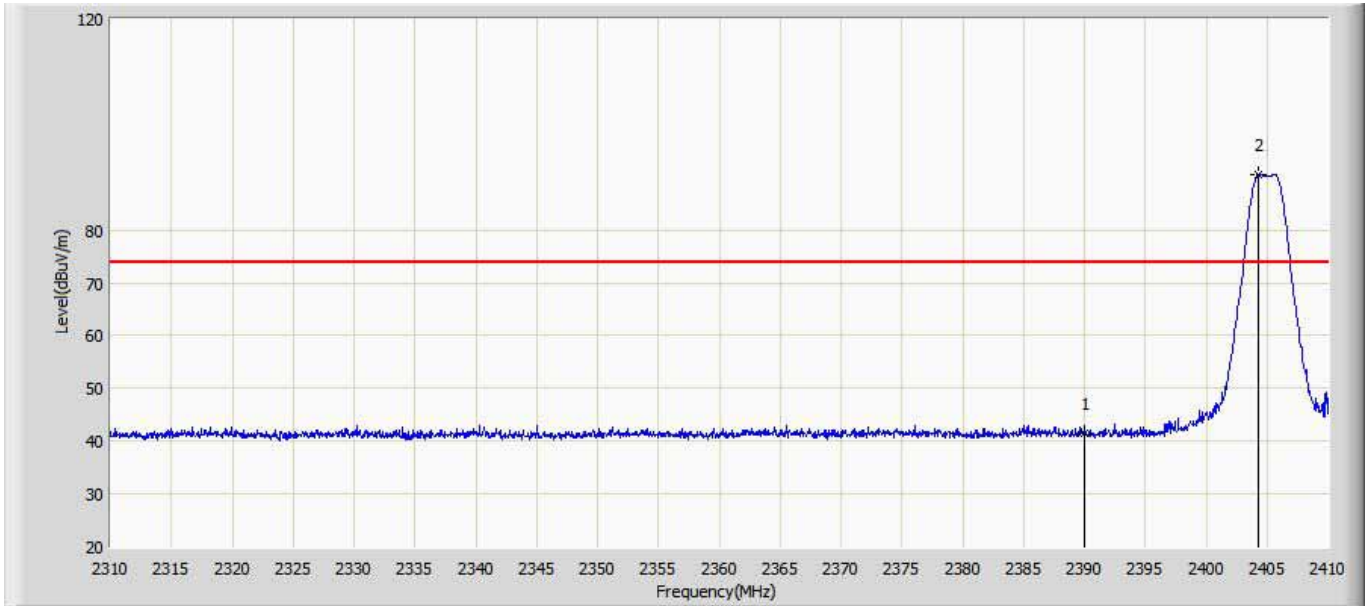

No	Mark	Frequency (MHz)	Measure Level (dBuV/m)	Reading Level (dBuV)	Over Limit (dB)	Limit (dBuV/m)	Factor (dB)	Type
1		2390.000	41.484	12.436	-32.516	74.000	29.048	PK
2	*	2404.300	90.539	61.603	N/A	N/A	28.936	PK

Engineer: Karl	
Site: AC5	Time: 2017/09/25 - 15:09
Limit: FCC_Part15.209_RE(3m)	Margin: 0
Probe: FCC	Polarity: Vertical
EUT: LED lamp	Power: AC 120V/60Hz
Note: Mode 1: Transmit at 2405MHz by zigbee	

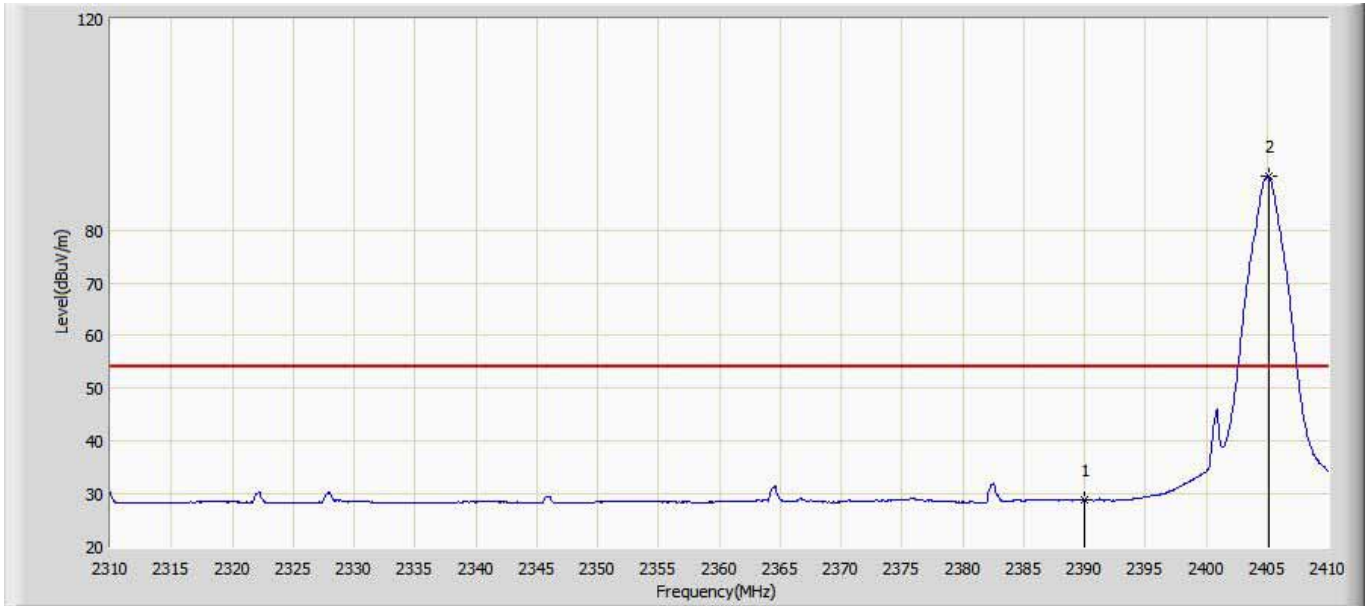

No	Mark	Frequency (MHz)	Measure Level (dBuV/m)	Reading Level (dBuV)	Over Limit (dB)	Limit (dBuV/m)	Factor (dB)	Type
1		2390.000	28.867	-0.181	-25.133	54.000	29.048	AV
2	*	2405.100	90.157	61.230	N/A	N/A	28.927	AV

Engineer: Karl	
Site: AC5	Time: 2017/09/25 - 15:11
Limit: FCC_Part15.209_RE(3m)	Margin: 0
Probe: FCC	Polarity: Vertical
EUT: LED lamp	Power: AC 120V/60Hz
Note: Mode 1:Transmit at 2405MHz by zigbee	

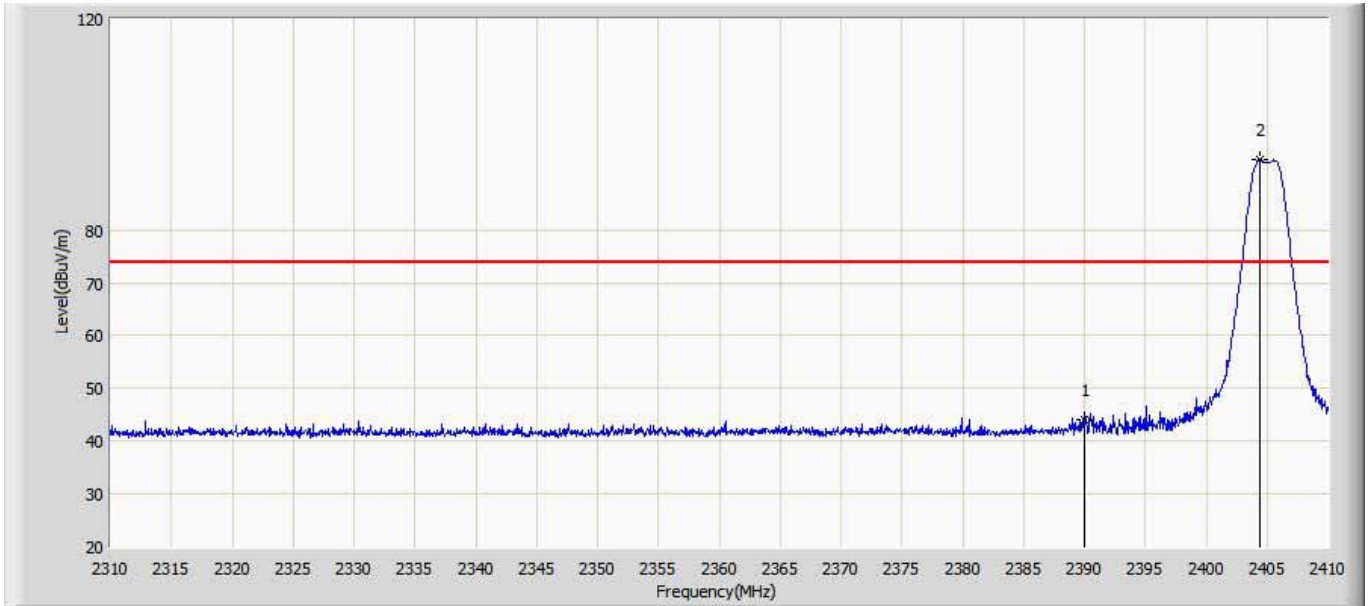

No	Mark	Frequency (MHz)	Measure Level (dBuV/m)	Reading Level (dBuV)	Over Limit (dB)	Limit (dBuV/m)	Factor (dB)	Type
1		2390.000	44.212	15.164	-29.788	74.000	29.048	PK
2	*	2404.450	93.235	64.301	N/A	N/A	28.934	PK

Engineer: Karl	
Site: AC5	Time: 2017/09/25 - 15:46
Limit: FCC_Part15.209_RE(3m)	Margin: 0
Probe: FCC	Polarity: Horizontal
EUT: LED lamp	Power: AC 120V/60Hz
Note: Mode 1: Transmit at 2450MHz by zigbee	

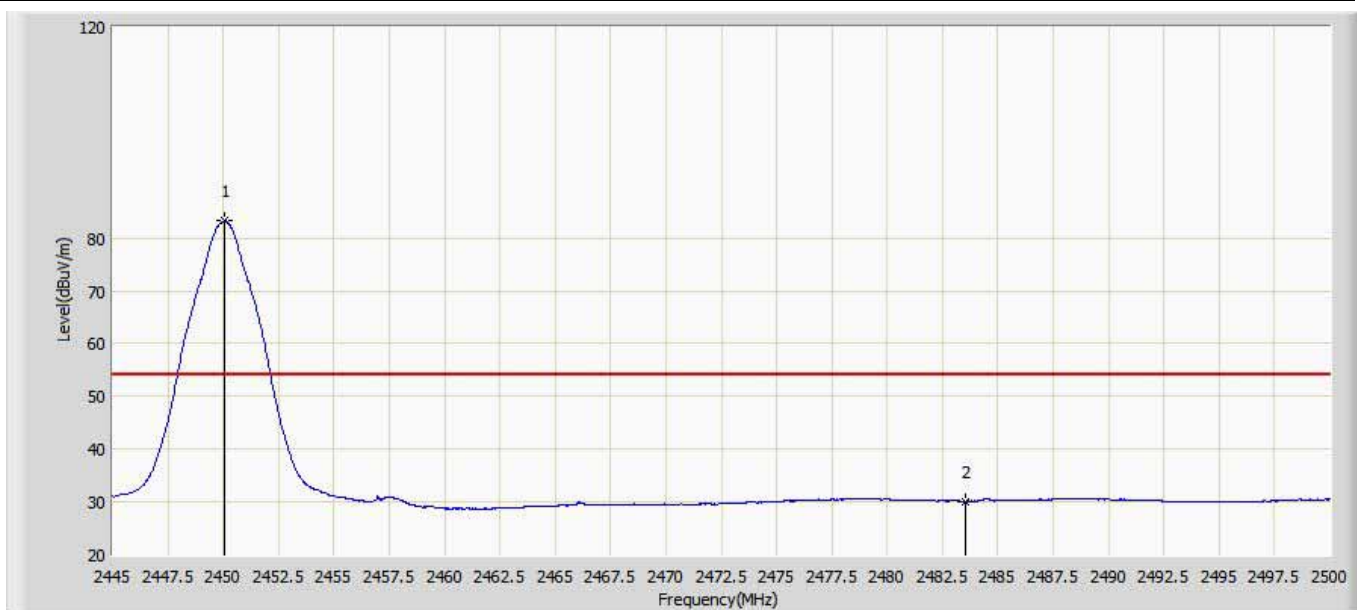

No	Mark	Frequency (MHz)	Measure Level (dBuV/m)	Reading Level (dBuV)	Over Limit (dB)	Limit (dBuV/m)	Factor (dB)	Type
1	*	2450.060	83.212	54.253	N/A	N/A	28.959	AV
2		2483.500	30.171	-0.313	-23.829	54.000	30.484	AV

Engineer: Karl	
Site: AC5	Time: 2017/09/25 - 15:51
Limit: FCC_Part15.209_RE(3m)	Margin: 0
Probe: FCC	Polarity: Horizontal
EUT: LED lamp	Power: AC 120V/60Hz
Note: Mode 1:Transmit at 2450MHz by zigbee	

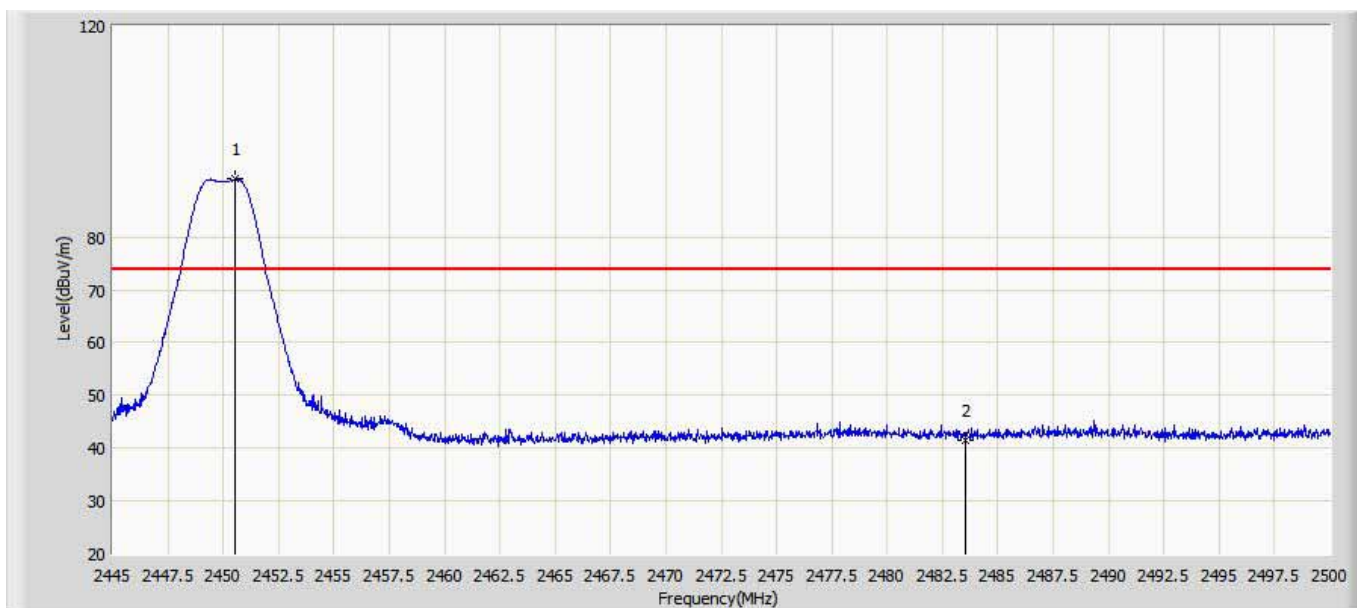

No	Mark	Frequency (MHz)	Measure Level (dBuV/m)	Reading Level (dBuV)	Over Limit (dB)	Limit (dBuV/m)	Factor (dB)	Type
1	*	2450.528	90.963	62.001	N/A	N/A	28.962	PK
2		2483.500	41.578	11.093	-32.422	74.000	30.484	PK

Engineer: Karl	
Site: AC5	Time: 2017/09/25 - 15:57
Limit: FCC_Part15.209_RE(3m)	Margin: 0
Probe: FCC	Polarity: Vertical
EUT: LED lamp	Power: AC 120V/60Hz
Note: Mode 1: Transmit at 2450MHz by zigbee	

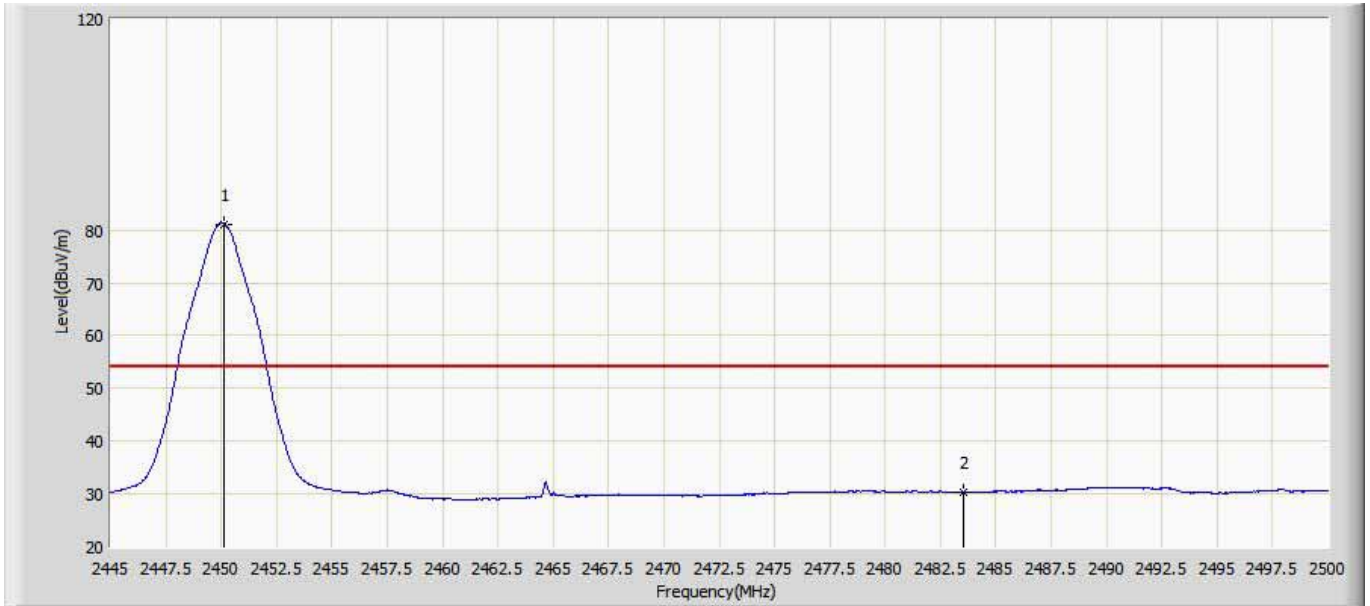

No	Mark	Frequency (MHz)	Measure Level (dBuV/m)	Reading Level (dBuV)	Over Limit (dB)	Limit (dBuV/m)	Factor (dB)	Type
1	*	2450.143	81.173	52.213	N/A	N/A	28.960	AV
2		2483.500	30.389	-0.095	-23.611	54.000	30.484	AV

Engineer: Karl	
Site: AC5	Time: 2017/09/25 - 15:59
Limit: FCC_Part15.209_RE(3m)	Margin: 0
Probe: FCC	Polarity: Vertical
EUT: LED lamp	Power: AC 120V/60Hz
Note: Mode 1:Transmit at 2450MHz by zigbee	



No	Mark	Frequency (MHz)	Measure Level (dBuV/m)	Reading Level (dBuV)	Over Limit (dB)	Limit (dBuV/m)	Factor (dB)	Type
1	*	2450.637	83.515	54.552	N/A	N/A	28.963	PK
2		2483.500	42.575	12.091	-31.425	74.000	30.484	PK

Engineer: Karl	
Site: AC5	Time: 2017/09/25 - 16:15
Limit: FCC_Part15.209_RE(3m)	Margin: 0
Probe: FCC	Polarity: Horizontal
EUT: LED lamp	Power: AC 120V/60Hz
Note: Mode 1:Transmit at 2480MHz by zigbee	

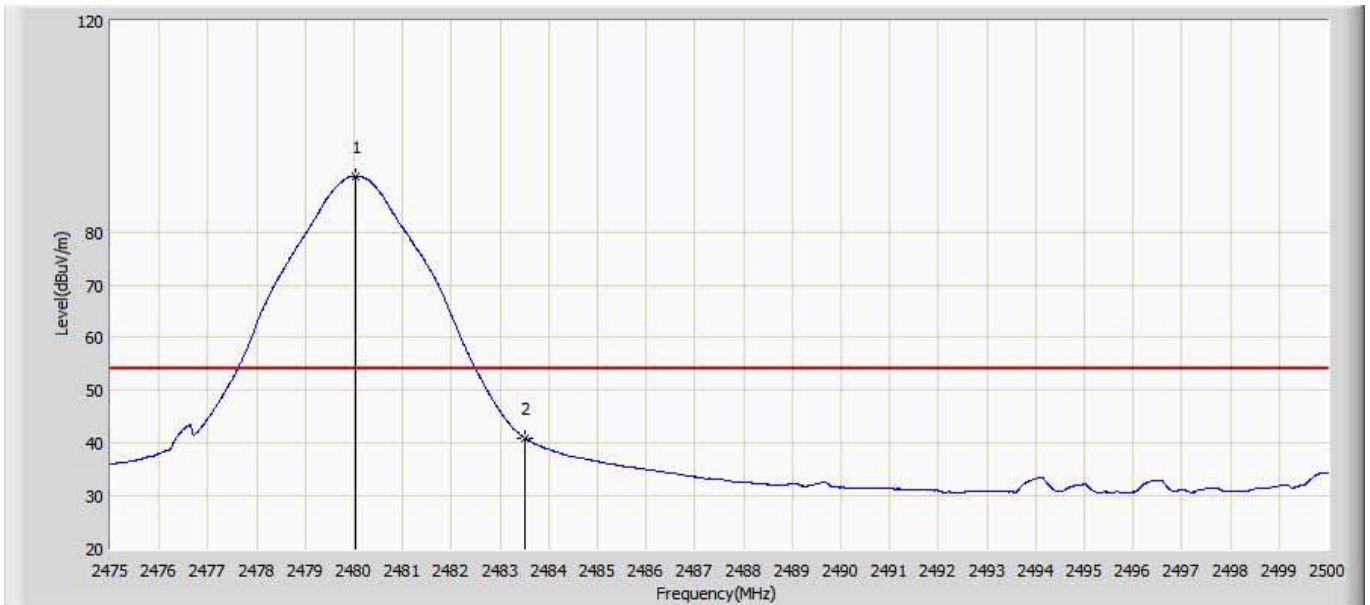

No	Mark	Frequency (MHz)	Measure Level (dBuV/m)	Reading Level (dBuV)	Over Limit (dB)	Limit (dBuV/m)	Factor (dB)	Type
1	*	2480.038	90.571	60.055	N/A	N/A	30.516	AV
2		2483.500	41.038	10.554	-12.962	54.000	30.484	AV

Engineer: Karl	
Site: AC5	Time: 2017/09/25 - 16:20
Limit: FCC_Part15.209_RE(3m)	Margin: 0
Probe: FCC	Polarity: Horizontal
EUT: LED lamp	Power: AC 120V/60Hz
Note: Mode 1:Transmit at 2480MHz by zigbee	

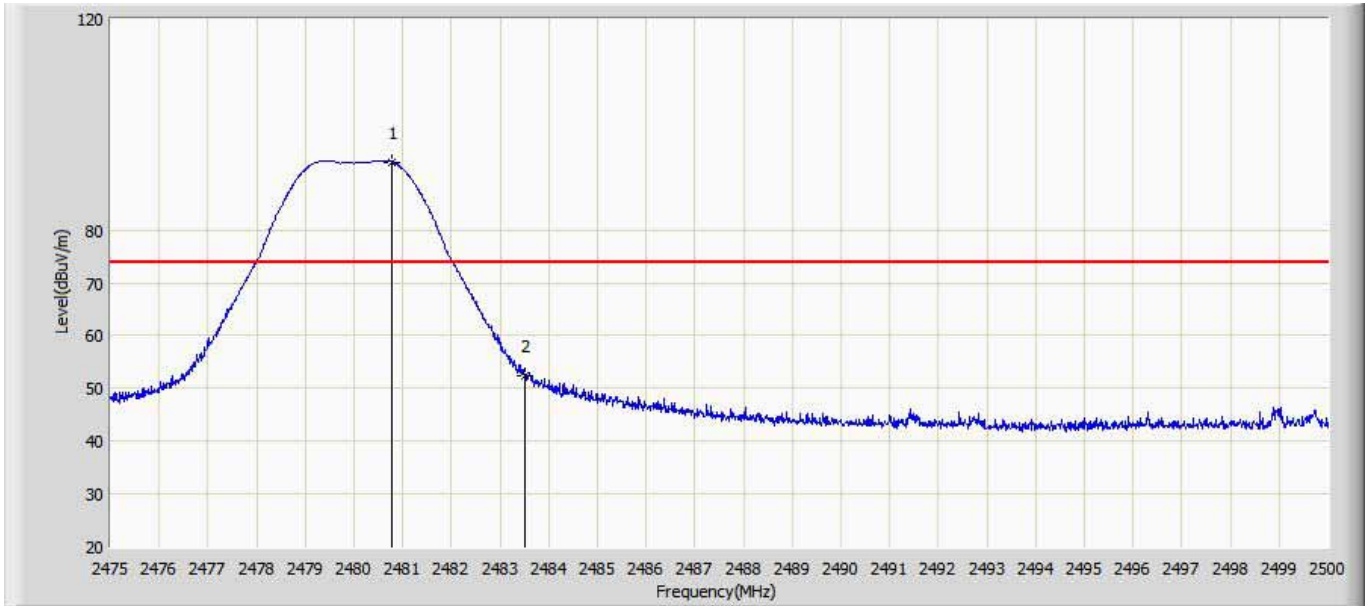

No	Mark	Frequency (MHz)	Measure Level (dBuV/m)	Reading Level (dBuV)	Over Limit (dB)	Limit (dBuV/m)	Factor (dB)	Type
1	*	2480.775	92.892	62.383	N/A	N/A	30.509	PK
2		2483.500	52.303	21.819	-21.697	74.000	30.484	PK

Engineer: Karl	
Site: AC5	Time: 2017/09/25 - 16:22
Limit: FCC_Part15.209_RE(3m)	Margin: 0
Probe: FCC	Polarity: Vertical
EUT: LED lamp	Power: AC 120V/60Hz
Note: Mode 1:Transmit at 2480MHz by zigbee	

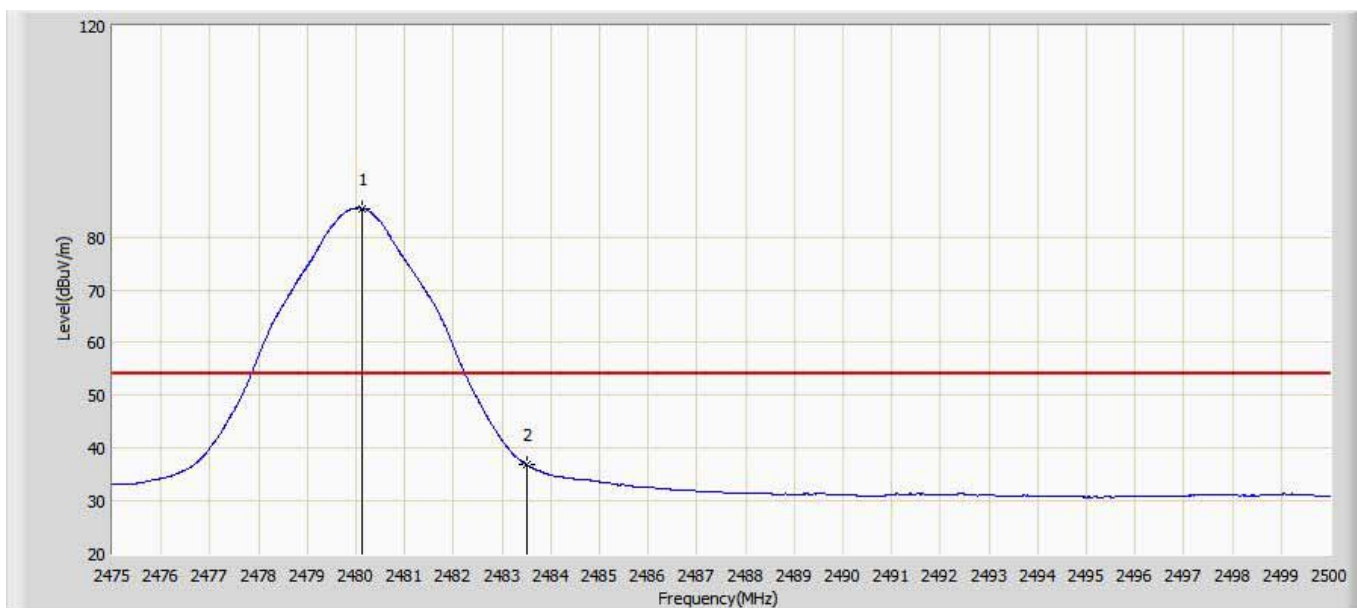

No	Mark	Frequency (MHz)	Measure Level (dBuV/m)	Reading Level (dBuV)	Over Limit (dB)	Limit (dBuV/m)	Factor (dB)	Type
1	*	2480.113	85.454	54.939	N/A	N/A	30.515	AV
2		2483.500	36.863	6.379	-17.137	54.000	30.484	AV

Engineer: Karl	
Site: AC5	Time: 2017/09/25 - 16:24
Limit: FCC_Part15.209_RE(3m)	Margin: 0
Probe: FCC	Polarity: Vertical
EUT: LED lamp	Power: AC 120V/60Hz
Note: Mode 1:Transmit at 2480MHz by zigbee	

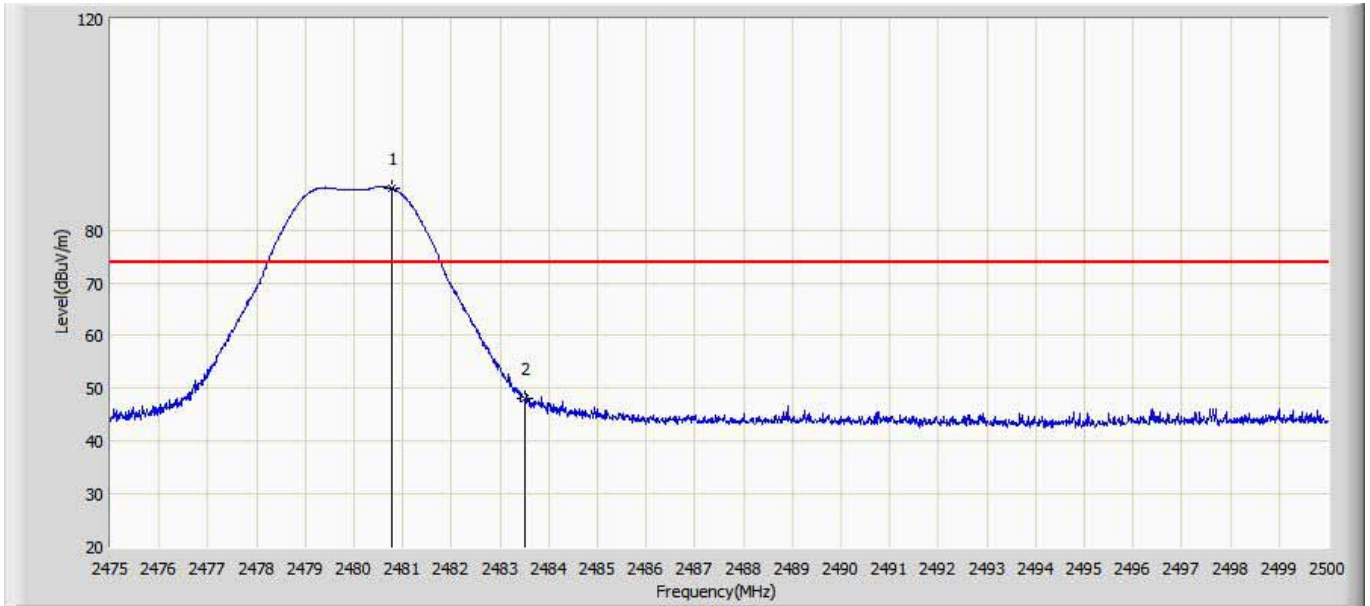

No	Mark	Frequency (MHz)	Measure Level (dBuV/m)	Reading Level (dBuV)	Over Limit (dB)	Limit (dBuV/m)	Factor (dB)	Type
1	*	2480.775	87.879	57.370	N/A	N/A	30.509	PK
2		2483.500	48.058	17.574	-25.942	74.000	30.484	PK

Test result for Alvis+Murata:

Engineer: Allen	
Site: AC5	Time: 2017/11/30 - 11:27
Limit: FCC_Part15.209_RE(3m)	Margin: 0
Probe: FCC	Polarity: Horizontal
EUT: LED lamp	Power: AC 120V/60Hz
Note: Mode 1:Transmit 2405MHz By ZigBee	

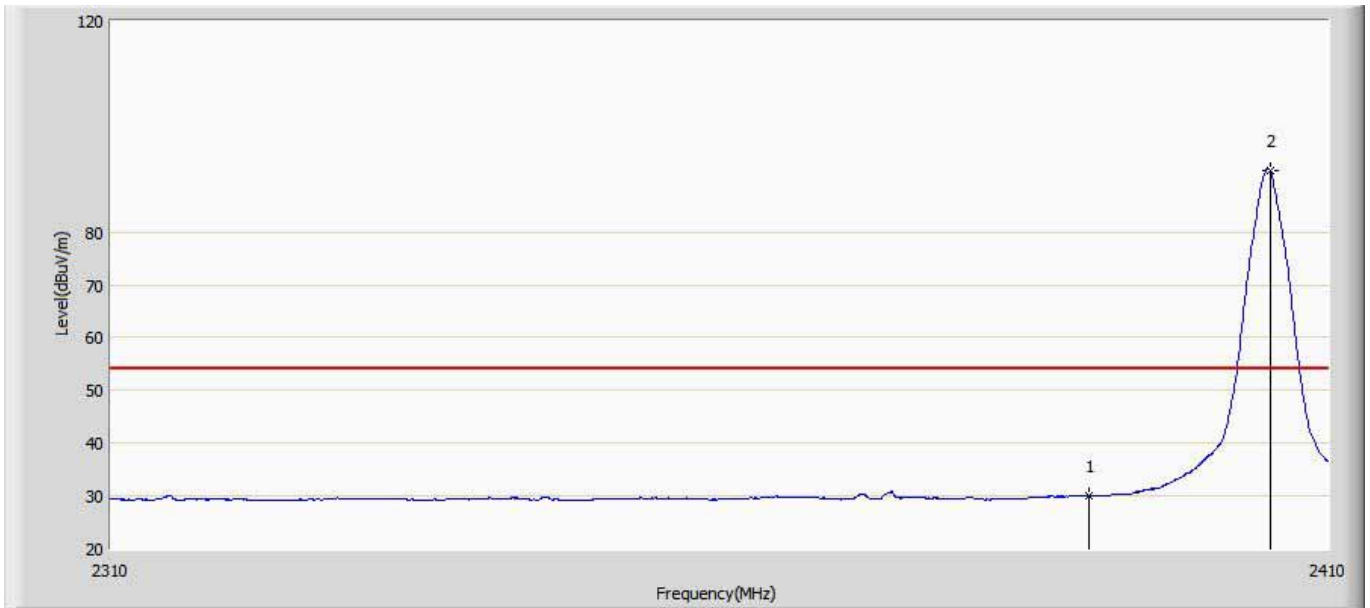

No	Mark	Frequency (MHz)	Measure Level (dBuV/m)	Reading Level (dBuV)	Over Limit (dB)	Limit (dBuV/m)	Factor (dB)	Type
1		2390.000	30.102	1.054	-23.898	54.000	29.048	AV
2	*	2405.150	91.710	62.784	37.710	54.000	28.926	AV

Engineer: Allen	
Site: AC5	Time: 2017/11/30 - 11:41
Limit: FCC_Part15.209_RE(3m)	Margin: 0
Probe: FCC	Polarity: Horizontal
EUT: LED lamp	Power: AC 120V/60Hz
Note: Mode 1:Transmit 2405MHz By ZigBee	

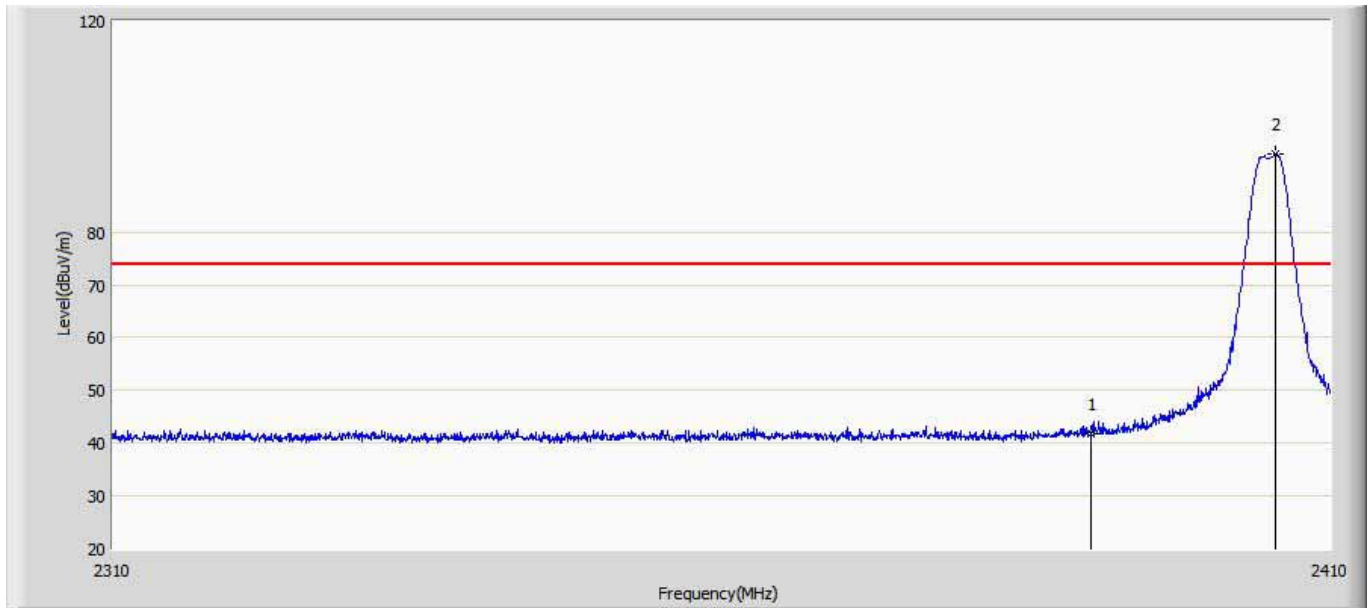

No	Mark	Frequency (MHz)	Measure Level (dBuV/m)	Reading Level (dBuV)	Over Limit (dB)	Limit (dBuV/m)	Factor (dB)	Type
1		2390.000	41.637	12.589	-32.363	74.000	29.048	PK
2	*	2405.400	94.693	65.769	20.693	74.000	28.924	PK

Engineer: Allen	
Site: AC5	Time: 2017/11/30 - 11:44
Limit: FCC_Part15.209_RE(3m)	Margin: 0
Probe: FCC	Polarity: Vertical
EUT: LED lamp	Power: AC 120V/60Hz
Note: Mode 1:Transmit 2405MHz By ZigBee	

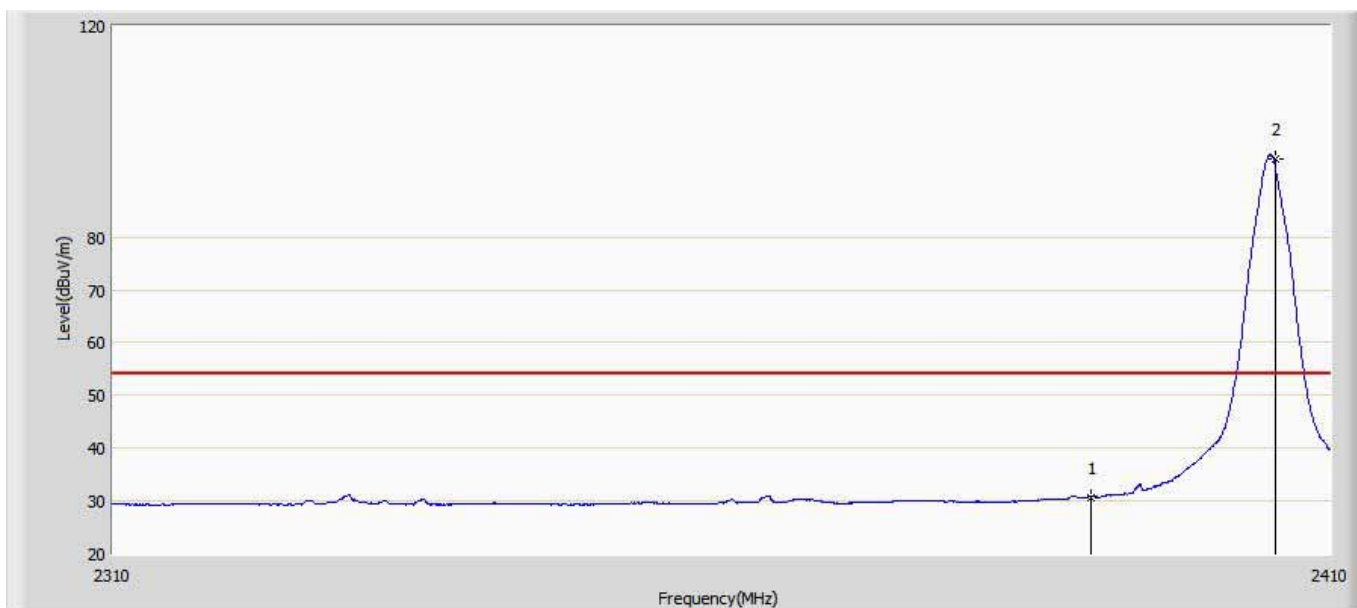

No	Mark	Frequency (MHz)	Measure Level (dBuV/m)	Reading Level (dBuV)	Over Limit (dB)	Limit (dBuV/m)	Factor (dB)	Type
1		2390.000	30.729	1.681	-23.271	54.000	29.048	AV
2	*	2405.400	94.693	65.769	40.693	54.000	28.924	AV

Engineer: Allen	
Site: AC5	Time: 2017/11/30 - 11:47
Limit: FCC_Part15.209_RE(3m)	Margin: 0
Probe: FCC	Polarity: Vertical
EUT: LED lamp	Power: AC 120V/60Hz
Note: Mode 1:Transmit 2405MHz By ZigBee	

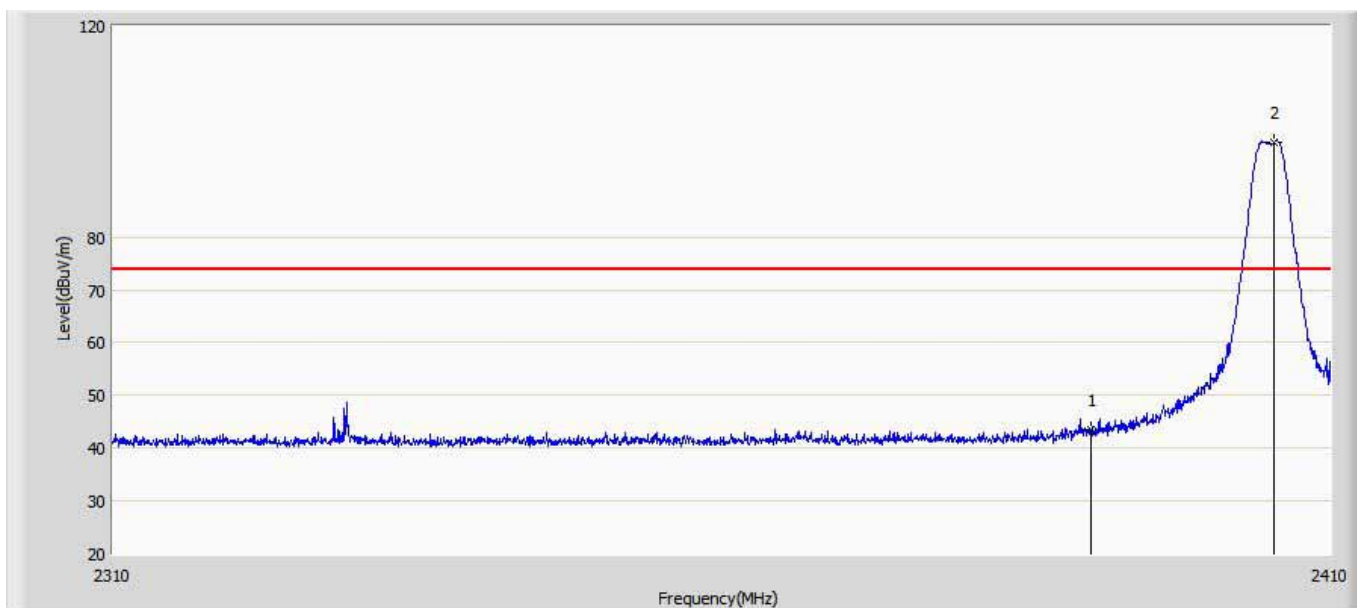

No	Mark	Frequency (MHz)	Measure Level (dBuV/m)	Reading Level (dBuV)	Over Limit (dB)	Limit (dBuV/m)	Factor (dB)	Type
1		2390.000	43.435	14.387	-30.565	74.000	29.048	PK
2	*	2405.250	97.880	68.955	23.880	74.000	28.925	PK

Engineer: Allen	
Site: AC5	Time: 2017/11/30 - 11:51
Limit: FCC_Part15.209_RE(3m)	Margin: 0
Probe: FCC	Polarity: Horizontal
EUT: LED lamp	Power: AC 120V/60Hz
Note: Mode 1:Transmit 2450MHz By ZigBee	

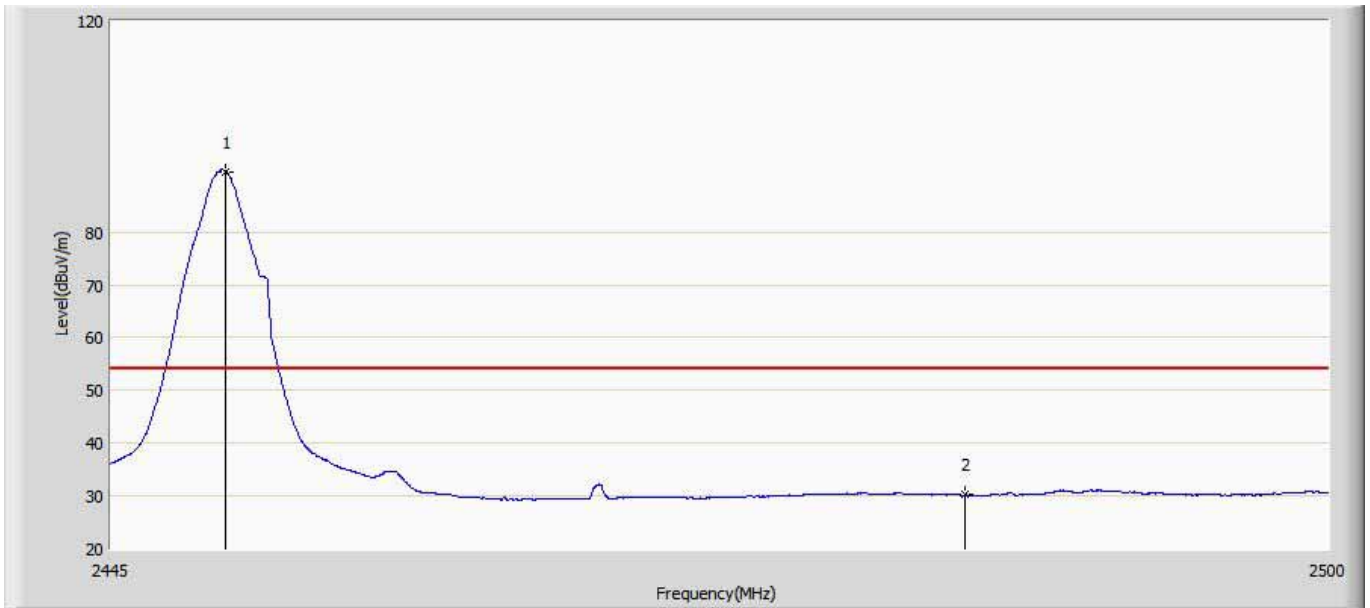

No	Mark	Frequency (MHz)	Measure Level (dBuV/m)	Reading Level (dBuV)	Over Limit (dB)	Limit (dBuV/m)	Factor (dB)	Type
1	*	2450.170	91.468	62.508	37.468	54.000	29.048	AV
2		2483.500	30.206	-0.278	-23.794	54.000	28.925	AV

Engineer: Allen	
Site: AC5	Time: 2017/11/30 - 13:26
Limit: FCC_Part15.209_RE(3m)	Margin: 0
Probe: FCC	Polarity: Horizontal
EUT: LED lamp	Power: AC 120V/60Hz
Note: Mode 1:Transmit 2450MHz By ZigBee	

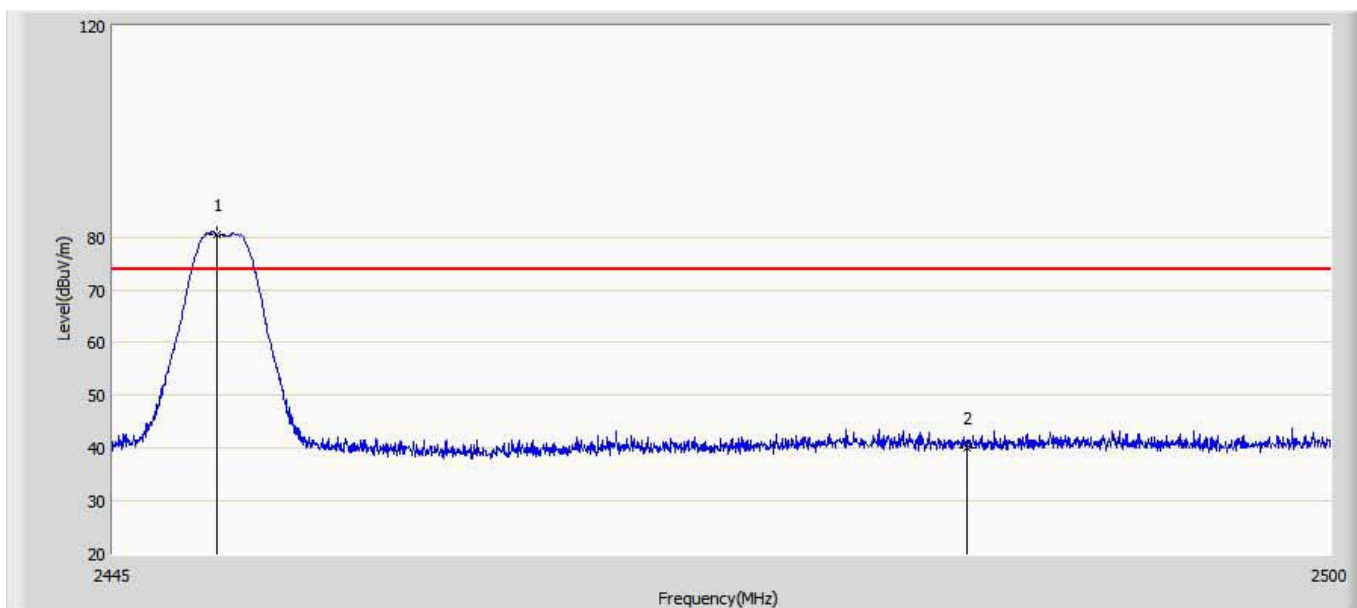

No	Mark	Frequency (MHz)	Measure Level (dBuV/m)	Reading Level (dBuV)	Over Limit (dB)	Limit (dBuV/m)	Factor (dB)	Type
1	*	2449.647	80.409	51.453	6.409	74.000	29.048	PK
2		2483.500	40.125	9.641	-33.875	74.000	28.925	PK

Engineer: Allen	
Site: AC5	Time: 2017/11/30 - 13:40
Limit: FCC_Part15.209_RE(3m)	Margin: 0
Probe: FCC	Polarity: Vertical
EUT: LED lamp	Power: AC 120V/60Hz
Note: Mode 1:Transmit 2450MHz By ZigBee	

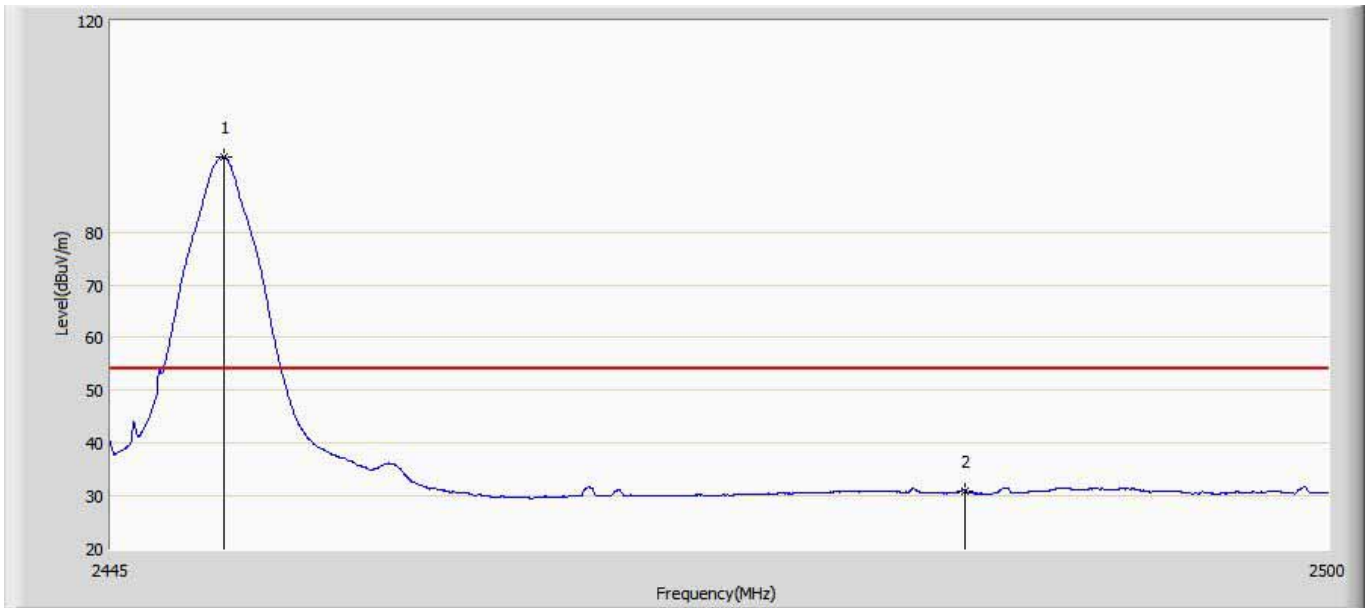

No	Mark	Frequency (MHz)	Measure Level (dBuV/m)	Reading Level (dBuV)	Over Limit (dB)	Limit (dBuV/m)	Factor (dB)	Type
1	*	2450.087	94.135	65.176	40.135	54.000	29.048	AV
2		2483.500	30.912	0.428	-23.088	54.000	28.925	AV

Engineer: Allen	
Site: AC5	Time: 2017/11/30 - 13:54
Limit: FCC_Part15.209_RE(3m)	Margin: 0
Probe: FCC	Polarity: Vertical
EUT: LED lamp	Power: AC 120V/60Hz
Note: Mode 1:Transmit 2450MHz By ZigBee	

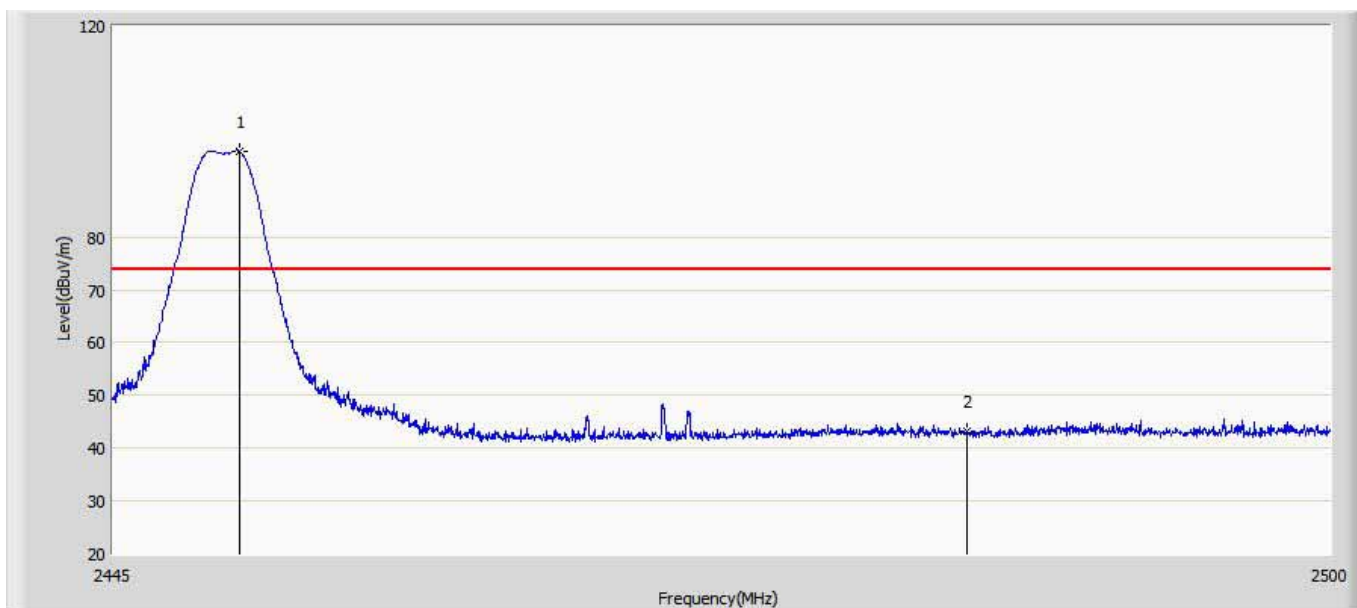

No	Mark	Frequency (MHz)	Measure Level (dBuV/m)	Reading Level (dBuV)	Over Limit (dB)	Limit (dBuV/m)	Factor (dB)	Type
1	*	2450.665	96.149	67.186	22.149	74.000	29.048	PK
2		2483.500	43.207	12.723	-30.793	74.000	28.925	PK

Engineer: Allen	
Site: AC5	Time: 2017/11/30 - 14:08
Limit: FCC_Part15.209_RE(3m)	Margin: 0
Probe: FCC	Polarity: Horizontal
EUT: LED lamp	Power: AC 120V/60Hz
Note: Mode 1:Transmit 2480MHz By ZigBee	

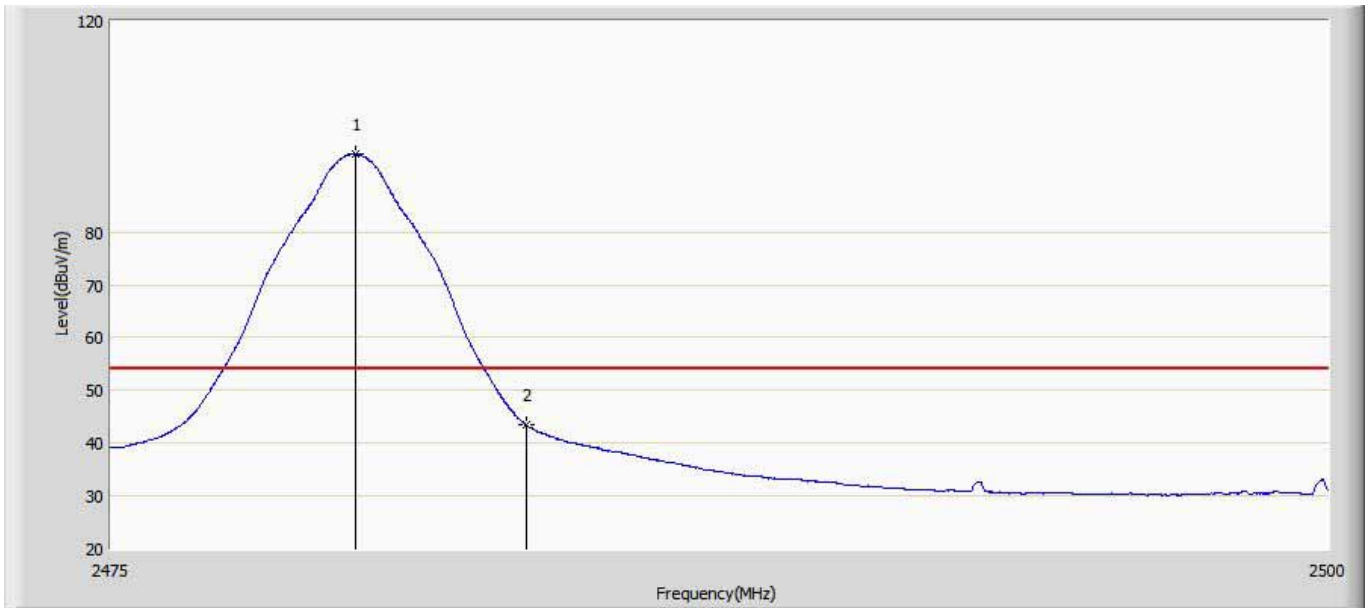

No	Mark	Frequency (MHz)	Measure Level (dBuV/m)	Reading Level (dBuV)	Over Limit (dB)	Limit (dBuV/m)	Factor (dB)	Type
1	*	2480.012	94.742	64.226	40.742	54.000	29.048	AV
2		2483.500	43.612	13.128	-10.388	54.000	28.925	AV

Engineer: Allen	
Site: AC5	Time: 2017/11/30 - 14:12
Limit: FCC_Part15.209_RE(3m)	Margin: 0
Probe: FCC	Polarity: Horizontal
EUT: LED lamp	Power: AC 120V/60Hz
Note: Mode 1:Transmit 2480MHz By ZigBee	

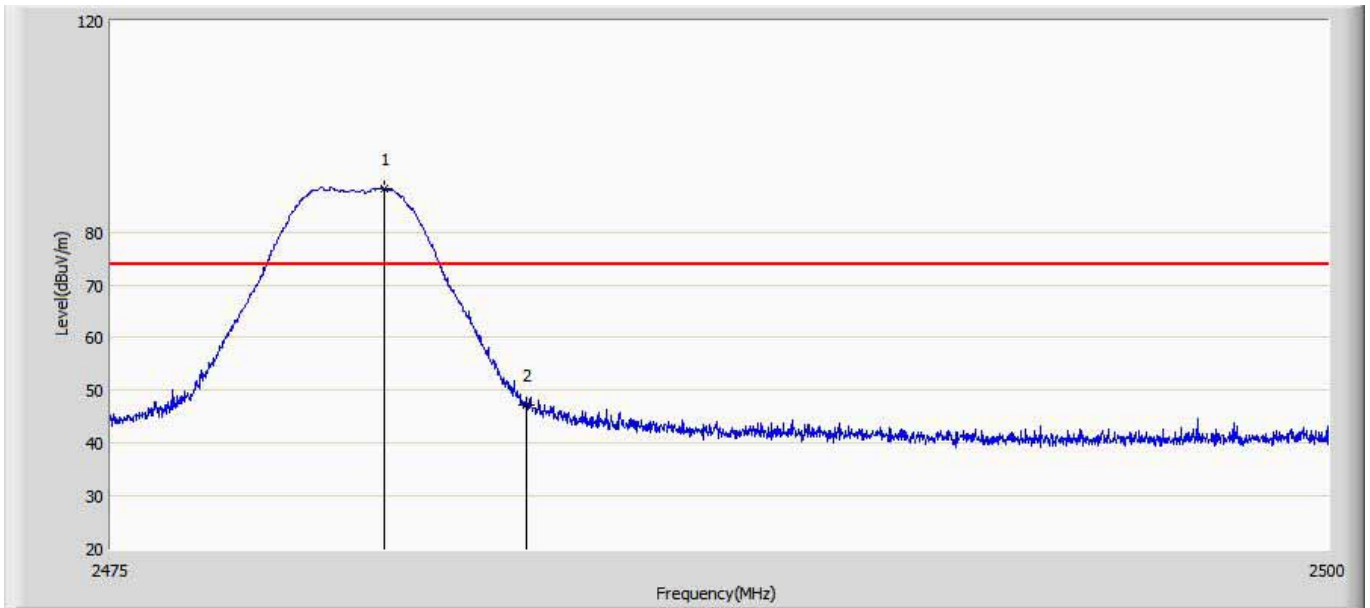

No	Mark	Frequency (MHz)	Measure Level (dBuV/m)	Reading Level (dBuV)	Over Limit (dB)	Limit (dBuV/m)	Factor (dB)	Type
1	*	2480.600	88.290	57.779	14.290	74.000	29.048	PK
2		2483.500	49.305	18.821	-24.695	74.000	28.925	PK

Engineer: Allen	
Site: AC5	Time: 2017/11/30 - 14:16
Limit: FCC_Part15.209_RE(3m)	Margin: 0
Probe: FCC	Polarity: Vertical
EUT: LED lamp	Power: AC 120V/60Hz
Note: Mode 1:Transmit 2480MHz By ZigBee	

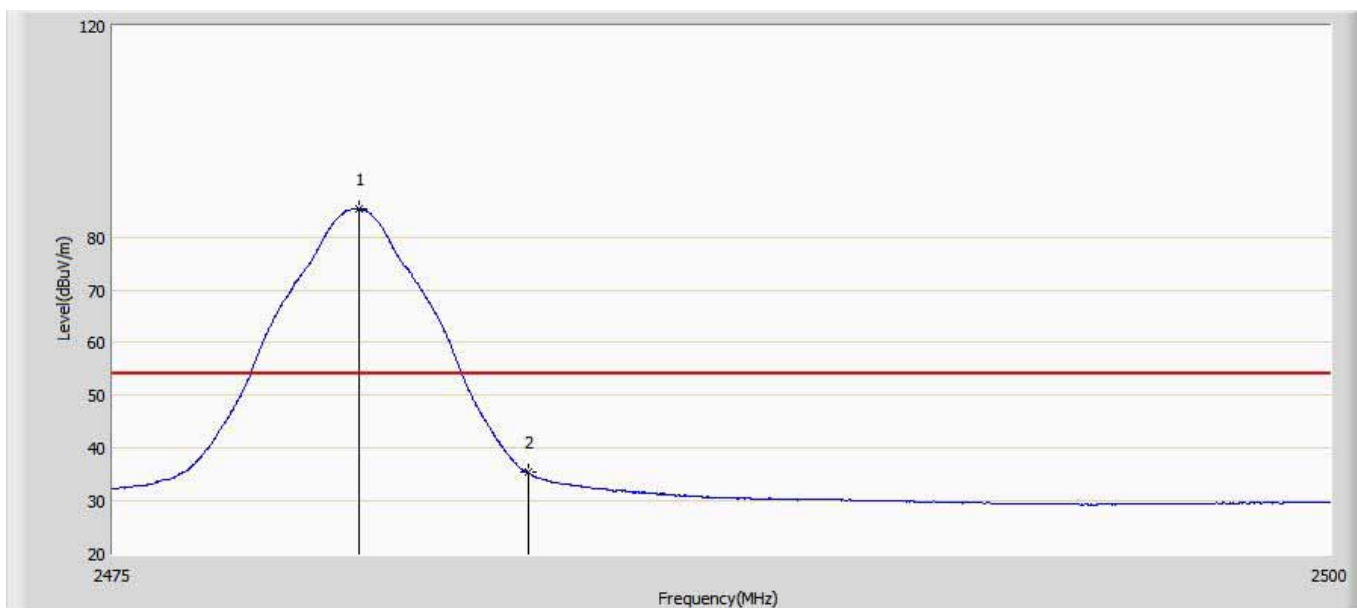

No	Mark	Frequency (MHz)	Measure Level (dBuV/m)	Reading Level (dBuV)	Over Limit (dB)	Limit (dBuV/m)	Factor (dB)	Type
1	*	2480.050	85.312	54.796	31.312	54.000	29.048	AV
2		2483.500	35.335	4.851	-18.665	54.000	28.925	AV

Engineer: Allen	
Site: AC5	Time: 2017/11/30 - 14:23
Limit: FCC_Part15.209_RE(3m)	Margin: 0
Probe: FCC	Polarity: Vertical
EUT: LED lamp	Power: AC 120V/60Hz
Note: Mode 1:Transmit 2480MHz By ZigBee	

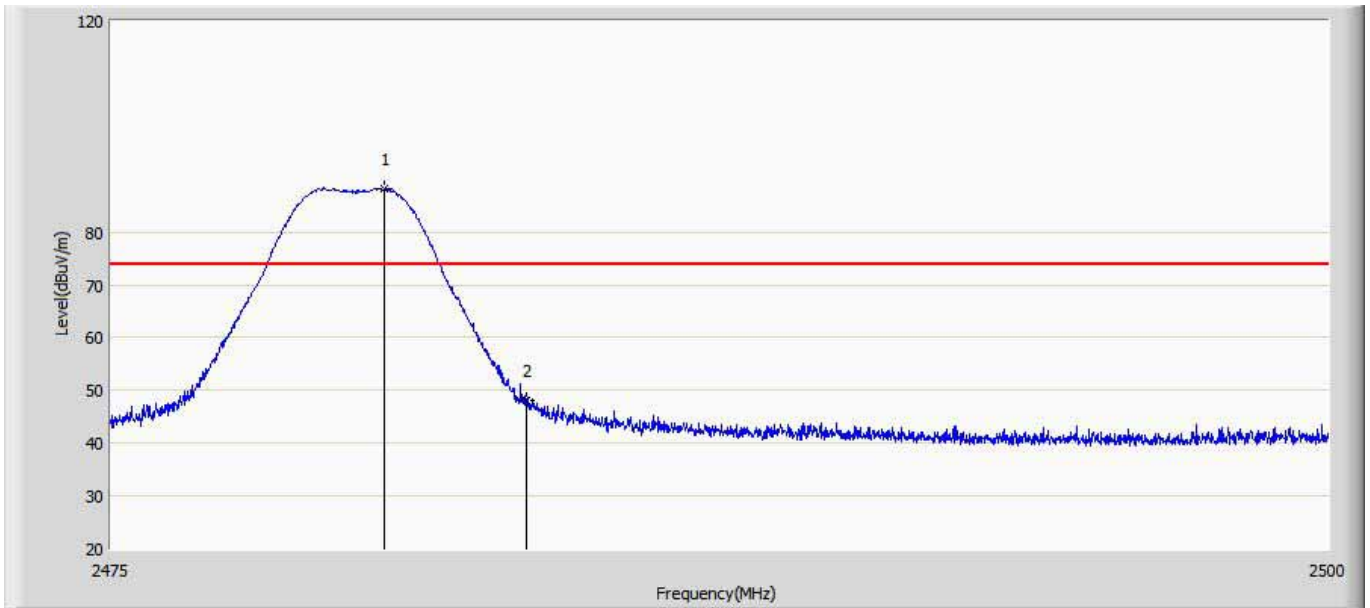

No	Mark	Frequency (MHz)	Measure Level (dBuV/m)	Reading Level (dBuV)	Over Limit (dB)	Limit (dBuV/m)	Factor (dB)	Type
1	*	2480.600	88.306	57.795	14.306	74.000	29.048	PK
2		2483.500	48.109	17.625	-25.891	74.000	28.925	PK

7. Occupied Bandwidth

7.1. Test Equipment

Occupied Bandwidth / TR-8					
Instrument	Manufacturer	Type No.	Serial No.	Cal. Date	Cal. Due Date
Spectrum Analyzer	Agilent	N9010A	MY48030494	2017.02.04	2018.02.03
EXA Spectrum Analyzer	Keysight	N9010A	MY55370495	2017.04.09	2018.04.08
MXA Signal Analyzer	Keysight	N9020A	MY56060147	2017.04.09	2018.04.08
Temperature/Humidity Meter	zhichen	ZC1-2	TR8-TH	2017.04.10	2018.04.09

Note: All equipment are calibrated with traceable calibrations. Each calibration is traceable to the national or international standards.

7.2. Test Setup

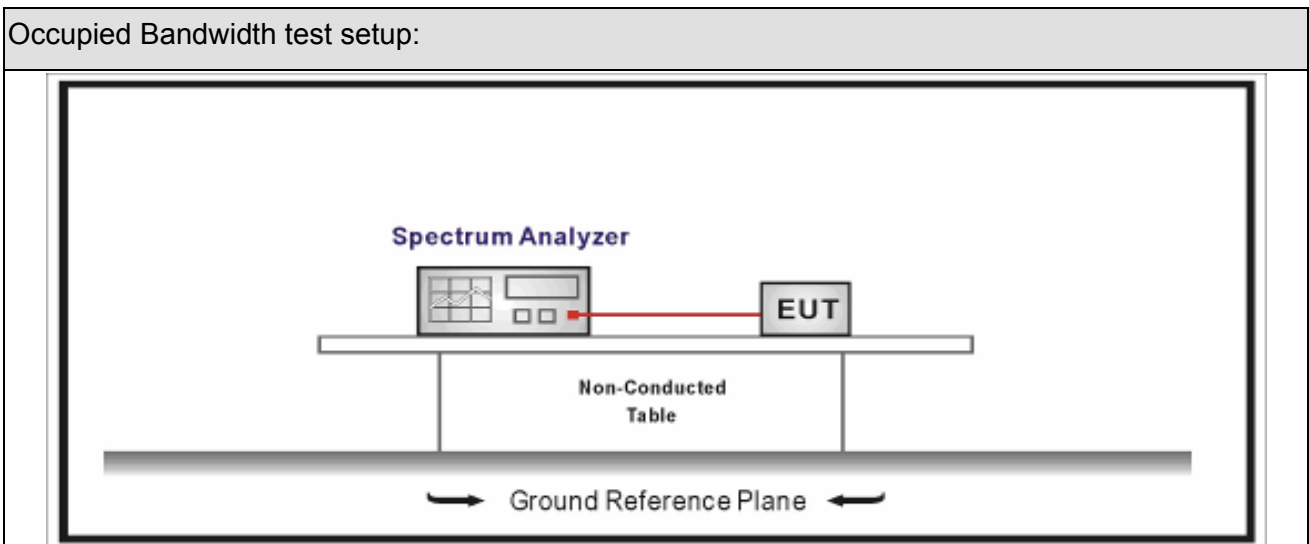



7.3. Limit

Occupied Bandwidth
Systems using digital modulation techniques operate in the 2400-2483.5 MHz. The minimum 6 dB bandwidth shall be at least 500 kHz

7.4. Test Procedure

Test Method			
	Reference Rule	Chapter	Description
<input checked="" type="checkbox"/>	ANSI C63.10	11.8	DTS bandwidth
<input type="checkbox"/>	ANSI C63.10	11.8.1	Option 1
<input checked="" type="checkbox"/>	ANSI C63.10	11.8.2	Option 2

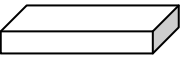
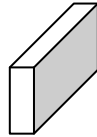
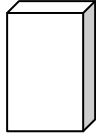
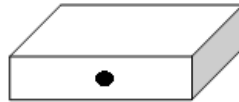
7.5. EUT test definition

Item	Occupied Bandwidth			
Device Category	<input type="checkbox"/>	Fixed point-to-point		
	<input type="checkbox"/>	Emit multiple directional beams, simultaneously or sequentially		
	<input checked="" type="checkbox"/>	Other cases		
Test mode	Mode 1			
Test method	<input type="checkbox"/>	Radiated		
		X Axis	Y Axis	Z Axis
				
		Worst Axis <input type="checkbox"/>	Worst Axis <input type="checkbox"/>	Worst Axis <input type="checkbox"/>
	<input checked="" type="checkbox"/>	Conducted		
	<input checked="" type="checkbox"/>	Chain 0		
				
	<input type="checkbox"/>	Chain 0	Chain 1	
				
	<input type="checkbox"/>	Chain 0	Chain 1	Chain 2
				

7.6. Test Result

Product Name	: LED lamp	Power	: AC 120V/60Hz
Test Mode	: Mode 1	Test Site	: TR-8
Test Date	: 2017.09.24	Test engineer	: Tommy

Mode	CH.	Test Freq. (MHz)	99% Occupied Bandwidth (kHz)	6dB Occupied Bandwidth (kHz)	Limit (kHz)	Result
1	11	2405	2254.3	1674	>500	Pass
1	20	2450	2267.2	1674	>500	Pass
1	26	2480	2283.0	1673	>500	Pass

Note : The worst case of Occupied Bandwidth as below:

Mode 1 CH26 (2480MHz)

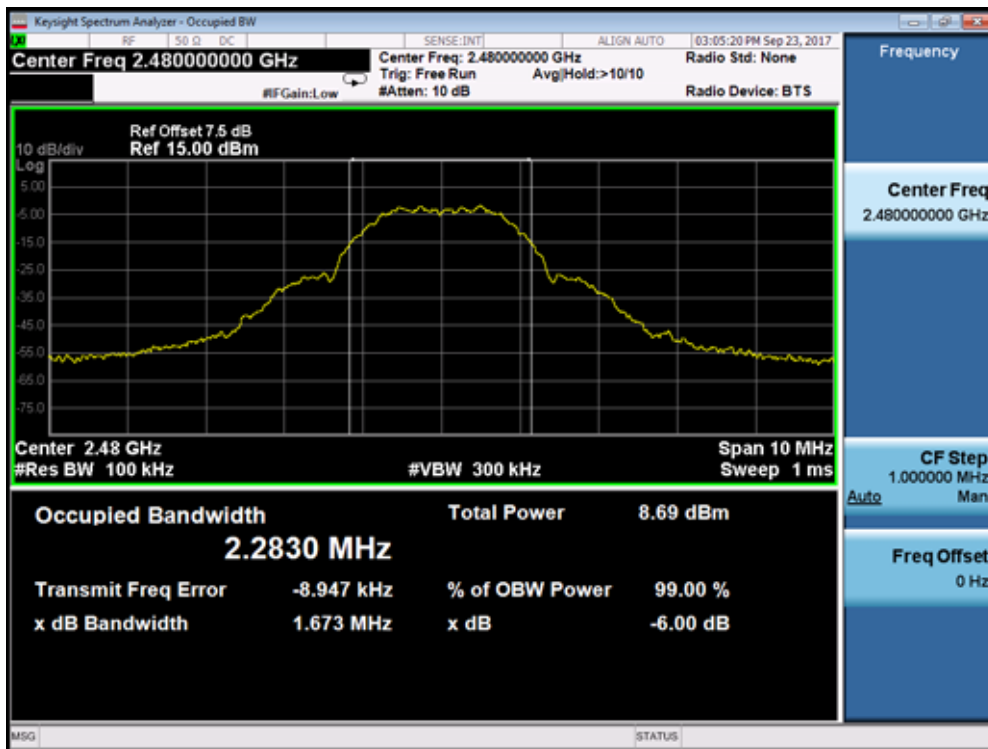

8. Fundamental emission output power

8.1. Test Equipment

Fundamental emission output power/ TR-8					
Instrument	Manufacturer	Type No.	Serial No.	Cal. Date	Cal. Due Date
Spectrum Analyzer	Agilent	E4446A	MY45300103	2017.01.04	2019.01.03
Spectrum Analyzer	Agilent	N9010A	MY48030494	2017.01.04	2019.01.03
Wideband Peak Power Meter	Anritsu	ML2495A	0905006	2016.10.14	2018.10.13
Power Sensor	Anritsu	MA2411B	0846014	2016.10.14	2018.10.13
Temperature/Humidity Meter	zhicheng	ZC1-2	TR8-TH	2017.04.10	2018.04.09

Note: All equipment are calibrated with traceable calibrations. Each calibration is traceable to the national or international standards.

8.2. Test Setup

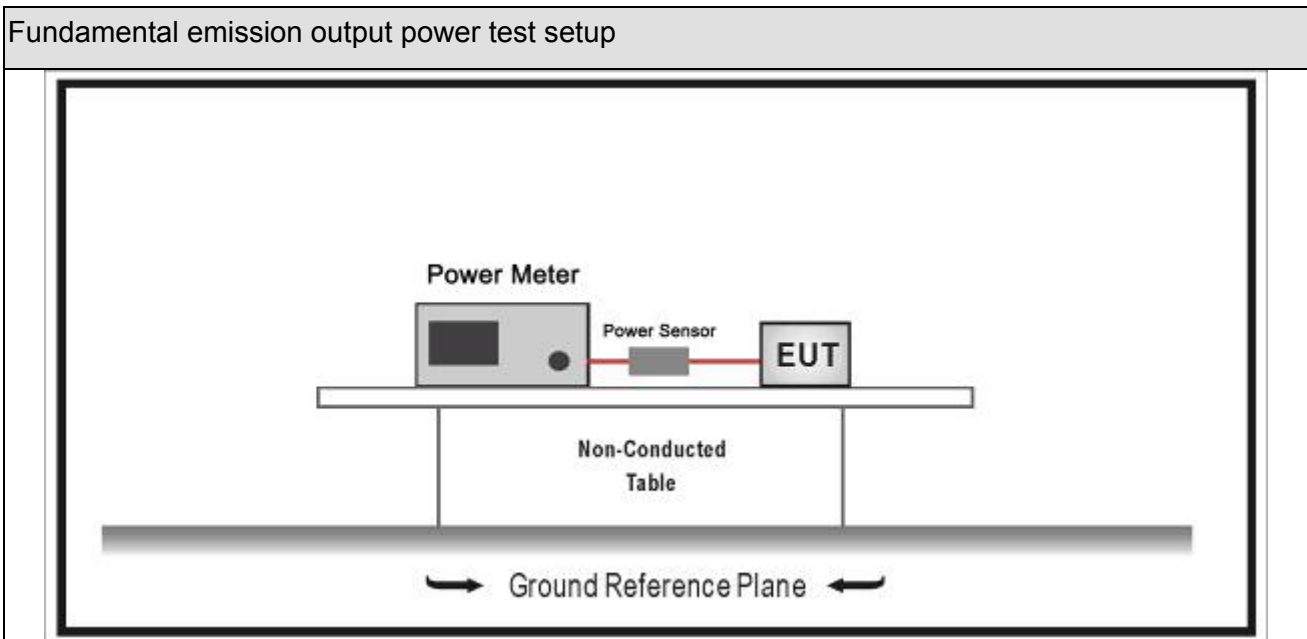





8.3. Limit

Fundamental emission output power Limit		
<input checked="" type="checkbox"/>	$G_{TX} < 6\text{dBi}$	$P_{out} \leq 30\text{dBm}$
<input type="checkbox"/>	$G_{TX} > 6\text{dBi}$	
<input type="checkbox"/>	Non-Fix point-point	$P_{out} \leq 30 - (G_{TX} - 6)$
<input type="checkbox"/>	Fix point-point	$P_{out} \leq 30 - [(G_{TX} - 6)]/3$
<input type="checkbox"/>	Point-to-multipoint	$P_{out} \leq 30 - (G_{TX} - 6)$
<input type="checkbox"/>	Overlap Beams	$P_{out} \leq 30 - [(G_{TX} - 6)]/3$
<input type="checkbox"/>	Aggregate power transmitted simultaneously on all beams	$P_{out} \leq 30 - [(G_{TX} - 6)]/3$
<input type="checkbox"/>	single directional beam	$P_{out} \leq 30 - [(G_{TX} - 6)]/3 + 8\text{dB}$
<p>Note 1 : G_{TX} directional gain of transmitting antennas.</p> <p>Note 2 : P_{out} is maximum peak conducted output power .</p>		

8.4. Test Procedure

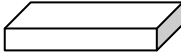
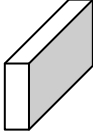
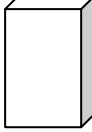
Fundamental emission output power Test Method						
	References Rule		Chapter	Description		
<input checked="" type="checkbox"/>	ANSI C63.10		11.9	Fundamental emission output power		
	<input checked="" type="checkbox"/>	ANSI C63.10		11.9.1	Maximum peak conducted output power	
		<input type="checkbox"/>	ANSI C63.10	11.9.1.1	RBW ≥ DTS bandwidth	
		<input type="checkbox"/>	ANSI C63.10	11.9.1.2	Integrated band power method	
		<input checked="" type="checkbox"/>	ANSI C63.10	11.9.1.3	PKPM1 Peak power meter method	
		<input type="checkbox"/>	ANSI C63.10		11.9.2	Maximum conducted (average) output power
		<input type="checkbox"/>	ANSI C63.10		11.9.2.2	Measurement using a spectrum analyzer (SA)
			<input type="checkbox"/>	ANSI C63.10	11.9.2.2.2	Method AVGSA-1(Duty cycle 98%)
			<input type="checkbox"/>	ANSI C63.10	11.9.2.2.3	Method AVGSA-1A(Duty cycle 98%)
			<input type="checkbox"/>	ANSI C63.10	11.9.2.2.4	Method AVGSA-2(Duty cycle 98%)
			<input type="checkbox"/>	ANSI C63.10	11.9.2.2.5	Method AVGSA-2A(Duty cycle 98%)
			<input type="checkbox"/>	ANSI C63.10	11.9.2.2.4	Method AVGSA-3
			<input type="checkbox"/>	ANSI C63.10	11.9.2.2.5	Method AVGSA-3A
		<input type="checkbox"/>	ANSI C63.10		11.9.2.3	Measurement using a power meter (PM)
			<input type="checkbox"/>	ANSI C63.10	11.9.2.3.1	Method AVGPM
		<input type="checkbox"/>	ANSI C63.10	11.9.2.3.2	Method AVGPM-G	

8.5. EUT test definition

Item	Fundamental emission output power			
Device Category	<input type="checkbox"/>	Fixed point-to-point		
	<input type="checkbox"/>	Emit multiple directional beams, simultaneously or sequentially		
	<input checked="" type="checkbox"/>	Other cases		
Test mode	Mode 1			
Test method	<input type="checkbox"/>	Radiated		
		X Axis	Y Axis	Z Axis
				
		Worst Axis <input type="checkbox"/>	Worst Axis <input type="checkbox"/>	Worst Axis <input type="checkbox"/>
	<input checked="" type="checkbox"/>	Conducted		
	<input checked="" type="checkbox"/>	Chain 0		
				
	<input type="checkbox"/>	Chain 0	Chain 1	
				
	<input type="checkbox"/>	Chain 0	Chain 1	Chain 2
				

8.6. Test Result

Product Name	: LED lamp	Power	: AC 120V/60Hz
Test Mode	: Mode 1	Test Site	: TR-8
Test Date	: 2018.01.03	Test engineer	: Tommy

Test result for Alvis+Diodes:

Mode	Channel	Test Frequency (MHz)	Measurement Power Output (dBm)	Limit (dBm)	Result
1	11	2405	8.76	30	Pass
1	20	2450	8.62	30	Pass
1	26	2480	8.06	30	Pass

Test result for Alvis+Murata:

Mode	Channel	Test Frequency (MHz)	Measurement Power Output (dBm)	Limit (dBm)	Result
1	11	2405	8.34	30	Pass
1	20	2450	7.81	30	Pass
1	26	2480	7.48	30	Pass

9. Power Spectral Density

9.1. Test Equipment

Power Spectral Density / TR-8					
Instrument	Manufacturer	Type No.	Serial No.	Cal. Date	Cal. Due Date
Spectrum Analyzer	Agilent	N9010A	MY48030494	2017.02.04	2018.02.03
EXA Spectrum Analyzer	Keysight	N9010A	MY55370495	2017.04.09	2018.04.08
MXA Signal Analyzer	Keysight	N9020A	MY56060147	2017.04.09	2018.04.08
Temperature/Humidity Meter	zhichen	ZC1-2	TR8-TH	2017.04.10	2018.04.09

Note: All equipment are calibrated with traceable calibrations. Each calibration is traceable to the national or international standards.

9.2. Test Setup

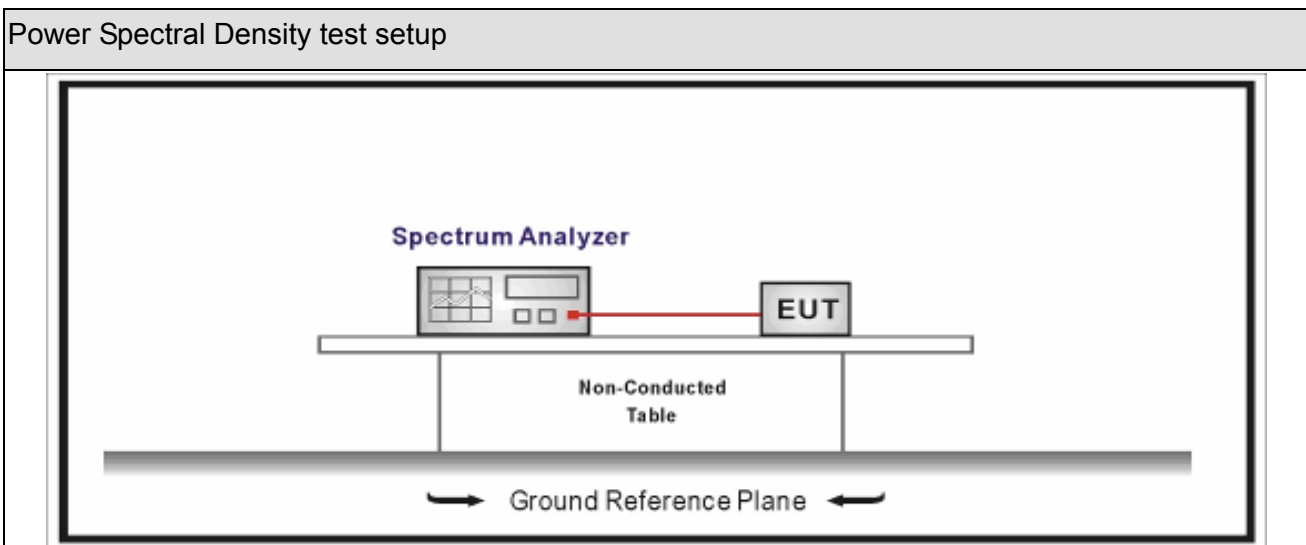

9.3. Limit

Power Spectral Density Limit
Power Spectral Density 8dBm/3kHz

9.4. Test Procedure

Power Spectral Density Test Method			
	References Rule	Chapter	Description
<input checked="" type="checkbox"/>	ANSI C63.10	11.10	Maximum power spectral density level in the fundamental emission
<input checked="" type="checkbox"/>	ANSI C63.10	11.10.2	Method PKPSD (peak PSD)
<input type="checkbox"/>	ANSI C63.10	11.10.3	Method AVGPSD-1(Duty cycle 98%)
<input type="checkbox"/>	ANSI C63.10	11.10.4	Method AVGPSD-1A(Duty cycle 98%)
<input type="checkbox"/>	ANSI C63.10	11.10.5	Method AVGPSD-2(Duty cycle < 98%)
<input type="checkbox"/>	ANSI C63.10	11.10.6	Method AVGPSD-2A(Duty cycle < 98%)
<input type="checkbox"/>	ANSI C63.10	11.10.7	Method AVGPSD-3
<input type="checkbox"/>	ANSI C63.10	11.10.8	Method AVGPSD-3A

9.5. EUT test definition

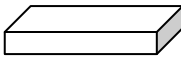
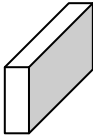
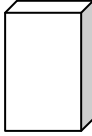
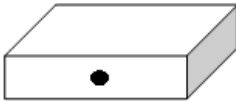
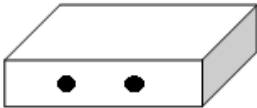
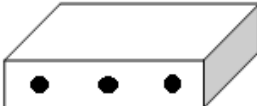
Item	Power Spectral Density Test Method			
Device Category	<input type="checkbox"/>	Fixed point-to-point		
	<input type="checkbox"/>	Emit multiple directional beams, simultaneously or sequentially		
	<input checked="" type="checkbox"/>	Other cases		
Test mode	Mode 1			
Test method	<input type="checkbox"/>	Radiated		
		X Axis	Y Axis	Z Axis
				
		Worst Axis <input type="checkbox"/>	Worst Axis <input type="checkbox"/>	Worst Axis <input type="checkbox"/>
	<input checked="" type="checkbox"/>	Conducted		
	<input checked="" type="checkbox"/>	Chain 0		
				
	<input type="checkbox"/>	Chain 0	Chain 1	
				
	<input type="checkbox"/>	Chain 0	Chain 1	Chain 2
				

9.6. Test Result

Product Name	: LED lamp	Power	: AC 120V/60Hz
Test Mode	: Mode 1	Test Site	: TR-8
Test Date	: 2017.09.15	Test engineer	: Tommy

Mode	Channel	Test Frequency (MHz)	Measurement PSD (dBm/3kHz)	Total PSD (dBm/3kHz)	Limit (dBm/3kHz)	Result
1	11	2405	-11.788	-11.788	8	Pass
1	15	2425	-12.936	-12.936	8	Pass
1	20	2450	-12.748	-12.748	8	Pass
1	25	2475	-14.817	-14.817	8	Pass
1	26	2480	-14.244	-14.244	8	Pass

Note : The worst case of Power Spectral Density as below:

Mode 1 CH11(2405MHz)

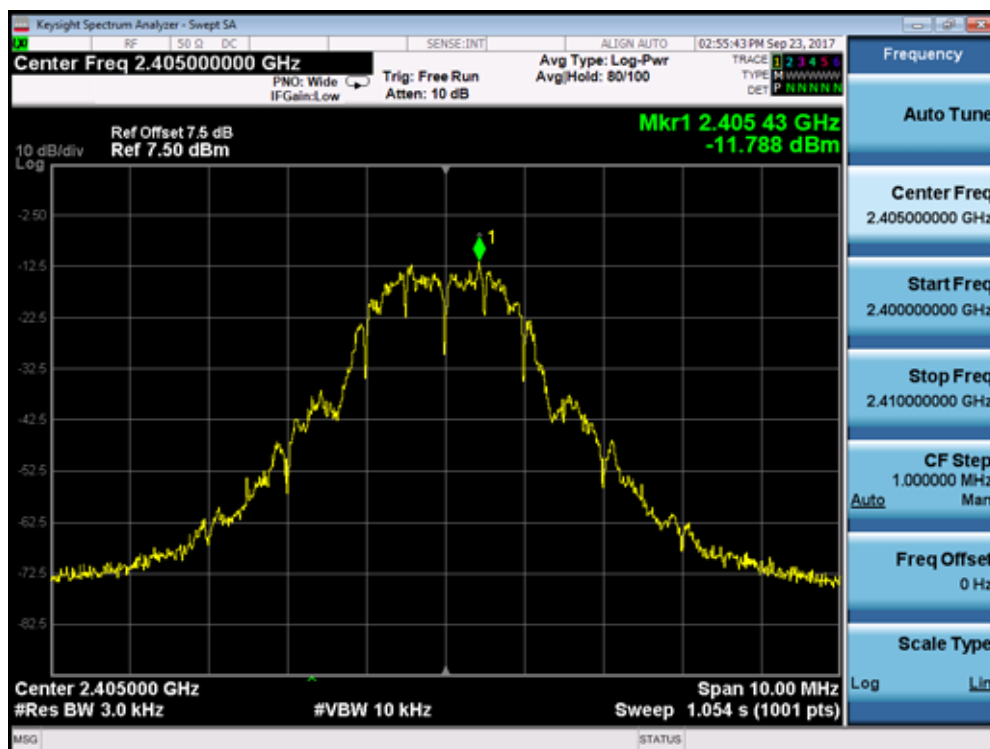

10. Antenna Requirement

10.1. Limit

Antenna Requirement Limit
<p>An intentional radiator shall be designed to ensure that no antenna other than that furnished by the responsible party shall be used with the device. The use of a permanently attached antenna or of an antenna that uses a unique coupling to the intentional radiator shall be considered sufficient to comply with the provisions of this section. The manufacturer may design the unit so that a broken antenna can be replaced by the user, but the use of a standard antenna jack or electrical connector is prohibited. This requirement does not apply to carrier current devices or to devices operated under the provisions of §15.211, §15.213, §15.217, §15.219, or §15.221. Further, this requirement does not apply to intentional radiators that must be professionally installed, such as perimeter protection systems and some field disturbance sensors, or to other intentional radiators which, in accordance with §15.31(d), must be measured at the installation site. However, the installer shall be responsible for ensuring that the proper antenna is employed so that the limits in this part are not exceeded.</p>

10.2. Antenna Connector Construction

Antenna Connector Construction	
<input checked="" type="checkbox"/>	The use of a permanently attached antenna
<input type="checkbox"/>	The antenna use of a unique coupling to the intentional radiator
<input type="checkbox"/>	The use of a nonstandard antenna jack or electrical connector
Please refer to the attached document "Internal Photograph" to show the antenna connector.	

_____ The End _____