



Test Report

FCC Part15 Subpart C & RSS-247 Issue 2

Product Name : LED lamp
Model No. : 9290019536
FCC ID : 2AGBW9290019536X
IC : 20812-9536X

Applicant : Signify (China) Investment Co., Ltd.

Address : Building no.9, Lane 888, Tianlin Road, Minhang District,
Shanghai 200233, China

Date of Receipt : Mar. 05, 2019
Test Date : Mar. 06, 2019~ Apr. 05, 2019
Issued Date : Apr. 17, 2019
Report No. : 1932052R-RF-US-P06V01
Report Version : V1.0

The test results relate only to the samples tested.

The test results shown in the test report are traceable to the national/international standard through the calibration of the equipment and evaluated measurement uncertainty herein.

This report must not be used to claim product endorsement by A2LA or any agency of the government.

The test report shall not be reproduced without the written approval of DEKRA Testing & Certification (Suzhou) Co., Ltd.

Test Report Certification

Issued Date : Apr. 17, 2019
Report No. : 1932052R-RF-US-P06V01



Product Name : LED lamp
 Applicant : Signify (China) Investment Co., Ltd.
 Address : Building no.9, Lane 888, Tianlin Road, Minhang District, Shanghai 200233, China
 Manufacturer : Signify (China) Investment Co., Ltd.
 Address : Building no.9, Lane 888, Tianlin Road, Minhang District, Shanghai 200233, China
 Model No. : 9290019536
 FCC ID : 2AGBW9290019536X
 IC : 20812-9536X
 EUT Voltage : 110-130 Vac, 50-60 Hz, 5.2W
 Test Voltage : AC 120V/60Hz
 Brand Name : PHILIPS
 Applicable Standard : FCC CFR Title 47 Part 15 Subpart C: 2017
 KDB 558074 D01v05
 RSS 247: Issue2; RSS GEN: Issue5
 ANSI C63.4:2014; ANSI C63.10:2013;
 Test Result : Complied
 Performed Location : DEKRA Testing and Certification (Suzhou) Co., Ltd.
 No.99 Hongye Rd., Suzhou Industrial Park, Suzhou, 215006, Jiangsu, China
 TEL: +86-512-6251-5088 / FAX: +86-512-6251-5098
 FCC Designation Number: CN1199; IC Lab Code: 4075B

Documented By : Kitty Li
 (Adm. Specialist: Kitty Li)

Reviewed By : Frank He
 (Senior Project Manager: Frank He)

Approved By : Jack Zhang
 (Engineering Supervisor: Jack Zhang)

TABLE OF CONTENTS

Description	Page
1. General Information.....	6
1.1. EUT Description	6
1.2. Working Frequency of Each Channel:	7
1.3. Antenna information	7
1.4. Mode of Operation.....	8
1.5. Tested System Details	8
1.6. Configuration of Tested System.....	9
1.7. EUT Exercise Software.....	10
2. Technical Test.....	11
2.1. Summary of Test Result.....	11
2.2. Test Environment.....	13
2.3. Measurement Uncertainty	13
3. AC Power Line Conducted Emission	14
3.1. Test Equipment.....	14
3.2. Test Setup.....	14
3.3. Limit.....	15
3.4. Test Procedure	15
3.5. Test Result.....	16
4. Emissions in restricted frequency bands	18
4.1. Test Equipment.....	18
4.2. Test Setup.....	19
4.3. Limit.....	20
4.4. Test Procedure	20
4.5. EUT test Axis definition.....	24
4.6. Test Result.....	25
5. Emissions in non-restricted frequency bands	45
5.1. Test Equipment.....	45
5.2. Test Setup.....	45
5.3. Limit.....	46
5.4. Test Procedure	47
5.5. EUT test Axis definition.....	48
5.6. Test Result.....	49
6. Radiated Emission Band Edge	50
6.1. Test Equipment.....	50
6.2. Test Setup.....	51
6.3. Limit.....	51
6.4. Test Procedure	52

- 6.5. EUT test definition 53
- 6.6. Duty Cycle 54
- 6.7. Test Result 55
- 7. Occupied Bandwidth 79
- 7.1. Test Equipment..... 79
- 7.2. Test Setup..... 79
- 7.3. Limit..... 80
- 7.4. Test Procedure 80
- 7.5. EUT test definition 81
- 7.6. Test Result..... 82
- 8. Fundamental emission output power 85
- 8.1. Test Equipment..... 86
- 8.2. Test Setup..... 86
- 8.3. Limit..... 87
- 8.4. Test Procedure 88
- 8.5. EUT test definition 89
- 8.6. Test Result..... 90
- 9. Power Spectral Density 91
- 9.1. Test Equipment..... 91
- 9.2. Test Setup..... 91
- 9.3. Limit..... 91
- 9.4. Test Procedure 92
- 9.5. EUT test definition 93
- 9.6. Test Result..... 94
- 10. Antenna Requirement..... 95
- 10.1. Limit..... 95
- 10.2. Antenna Connector Construction..... 95

History of This Test Report

REPORT NO.	VERSION	DESCRIPTION	ISSUED DATE
1932052R-RF-US-P06V01	V1.0	Initial Issued Report	Apr. 17, 2019

1. General Information

1.1. EUT Description

Product Name	LED lamp
Model No.	9290019536
EUT Voltage	110-130 Vac, 50-60 Hz, 5.2W
Test Voltage	AC 120V/60Hz
Zigbee	
Frequency Range	2405 ~ 2480MHz
Channel Number	16
Type of Modulation	DSSS-OQPSK
Data Rate	250kbps
Antenna Type	Reference to Antenna List

Note 1: LED lamp supports three kinds of Crystal oscillator (murata/ Diodes/kdx), there is not any change in RF design, circuitry or construction for this device, including RF parameters (antenna, software, firmware and hardware versions, power, frequency ranges, etc.), so only power, spurious emission and band-edge were tested for different crystal oscillator, the test data of worse mode is showed with other test items.

1.2. Working Frequency of Each Channel:

Zigbee Working Frequency of Each Channel:							
Channel	Frequency	Channel	Frequency	Channel	Frequency	Channel	Frequency
11	2405 MHz	12	2410 MHz	13	2415 MHz	14	2420 MHz
15	2425 MHz	16	2430 MHz	17	2435 MHz	18	2440 MHz
19	2445 MHz	20	2450 MHz	21	2455 MHz	22	2460 MHz
23	2465 MHz	24	2470 MHz	25	2475 MHz	26	2480 MHz

1.3. Antenna information

Antenna manufacturer	N/A						
Antenna Delivery	<input checked="" type="checkbox"/>	1*TX+1*RX	<input type="checkbox"/>	2*TX+2*RX	<input type="checkbox"/>	3*TX+3*RX	
Antenna technology	<input checked="" type="checkbox"/>	SISO					
	<input type="checkbox"/>	MIMO	<input type="checkbox"/>	Basic			
			<input type="checkbox"/>	CDD			
			<input type="checkbox"/>	Beam-forming			
Antenna Type	<input type="checkbox"/>	External	<input type="checkbox"/>	Dipole			
	<input checked="" type="checkbox"/>	Internal	<input type="checkbox"/>	PIFA			
			<input checked="" type="checkbox"/>	PCB			
			<input type="checkbox"/>	Ceramic Chip Antenna			
			<input type="checkbox"/>	Metal plate type F antenna			
Antenna Gain	1.5dBi						

1.4. Mode of Operation

Test Mode
Mode 1: Transmit

1.5. Tested System Details

The types for all equipment, plus descriptions of all cables used in the tested system (including inserted cards) are:

No.	Product	Manufacturer	Model No.	Serial No.	Power Cord
1	Notebook	Think Pad	2526	LV-A3285	Power by adapter
2	Zigbee Receiver	N/A	N/A	N/A	N/A
A	USB Control Cable	N/A	N/A	N/A	Shield, 1m
B	USB Control Cable	N/A	N/A	N/A	Shield, 10m

1.6. Configuration of Tested System

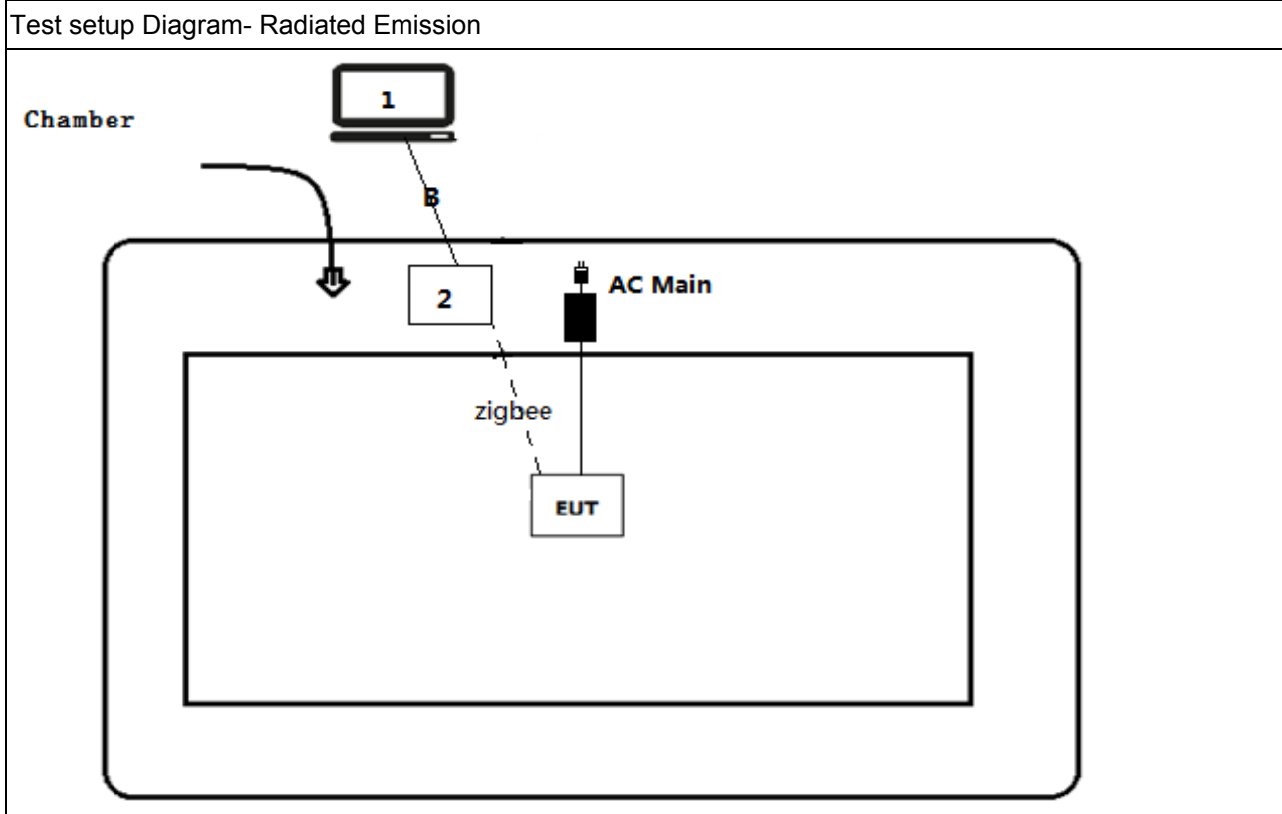
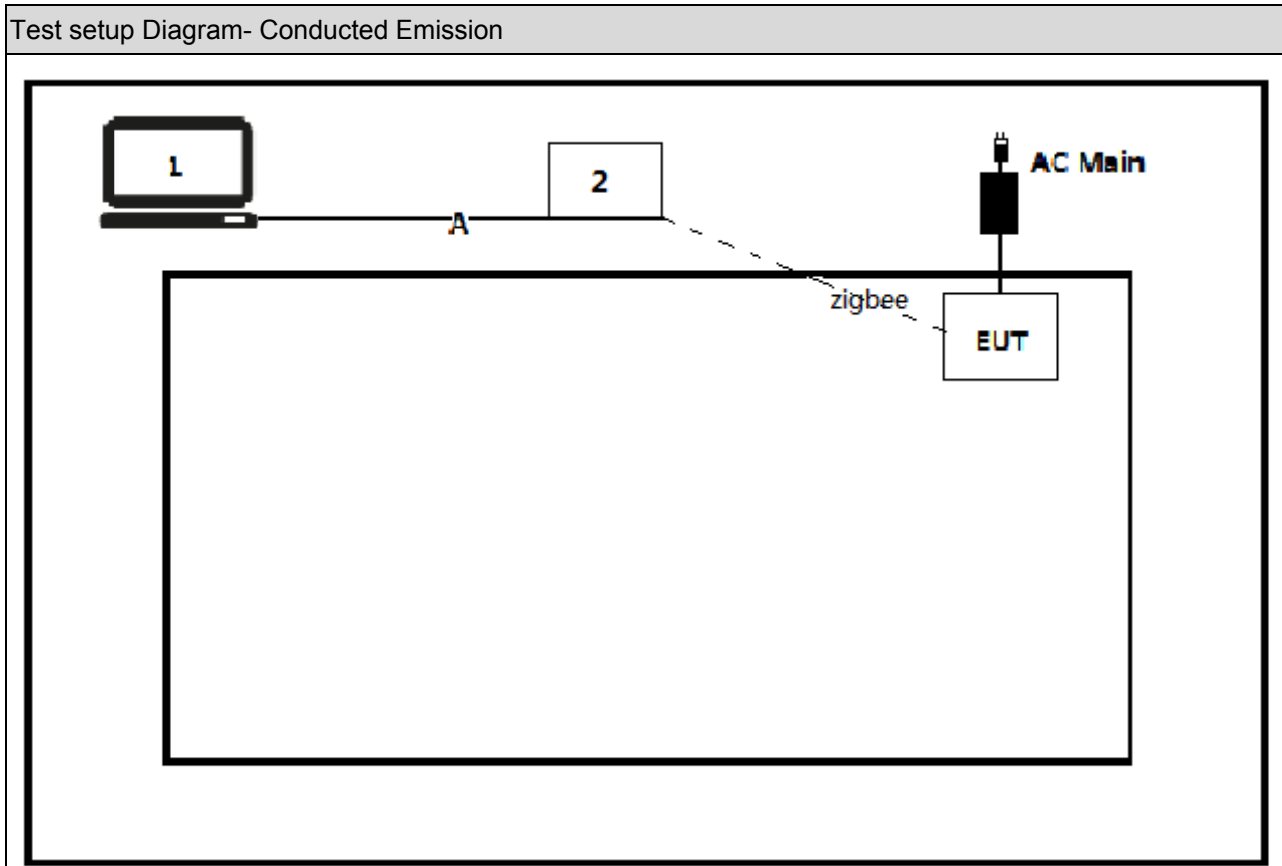

1.7. EUT Exercise Software

1	Setup the EUT and simulators as shown on above.
2	Turn on the power of equipment.
3	Run the test software (HueApprobaton Tool).
4	Select the transmission mode and test channel, then start test.

2. Technical Test

2.1. Summary of Test Result

FCC:

Performed Test Item	Normative References	Worst case mode	Limit	Result
AC Power Line Conducted Emission	FCC CFR Title 47 Part 15 Subpart C: 2015 Section 15.207	Mode 1	FCC 15.207	PASS
Emissions in restricted frequency bands	FCC CFR Title 47 Part 15 Subpart C: 2015 Section 15.209	Mode 1	FCC 15.209	PASS
Emissions in non-restricted frequency bands	FCC CFR Title 47 Part 15 Subpart C: 2015 Section 15.247(d)	Mode 1	20dBc	PASS
Radiated Emission Band Edge	FCC CFR Title 47 Part 15 Subpart C: 2015 15.247(d)	Mode 1	FCC 15.209	PASS
Occupied Bandwidth	FCC CFR Title 47 Part 15 Subpart C: 2015 Section 15.247(a)(2)	Mode 1	500kHz	PASS
Fundamental emission output power	FCC CFR Title 47 Part 15 Subpart C: 2015 Section 15.247(b)(3)	Mode 1	30dBm	PASS
Power Spectral Density	FCC CFR Title 47 Part 15 Subpart C: 2015 Section 15.247(e)	Mode 1	8dBm/3kHz	PASS
Antenna Requirement	FCC CFR Title 47 Part 15 Subpart C: 2015 Section 15.203	N/A	FCC 15.203	PASS

ISED:

Performed Test Item	Normative References	Worse case mode	Limit	Result
AC Power Line Conducted Emission	RSS-Gen Issue 4 November 2014 Section 8.8	N/A	RSS-Gen	PASS
Emissions in restricted frequency bands	RSS-247 Issue 1 May 2015 Section 5.5	Mode1	RSS-247	PASS
Emissions in non-restricted frequency bands	RSS-247 Issue 1 May 2015 Section 5.5	Mode1	30dBc	PASS
Radiated Emission Band Edge	RSS-Gen Issue 4 November 2014 Section 8.10	Mode1	RSS-Gen	PASS
Occupied Bandwidth	RSS-Gen Issue 4 November 2014 Section 6.6 RSS-247 Issue 1 May 2015 Section 5.2	Mode1	500kHz	PASS
Fundamental emission output power	RSS-247 Issue 1 May 2015 Section 5.4	Mode1	30dBm	PASS
Power Spectral Density	RSS-247 Issue 1 May 2015 Section 5.2	Mode1	8dBm/3kHz	PASS
Antenna Requirement	FCC CFR Title 47 Part 15 Subpart C: 2015 Section 15.203	N/A	RSS-Gen	PASS

2.2. Test Environment

Items	Required (IEC 68-1)	Actual
Temperature (°C)	15-35	21
Humidity (%RH)	25-75	50
Barometric pressure (mbar)	860-1060	950-1000

2.3. Measurement Uncertainty

Test Items	Uncertainty
AC Power Line Conducted Emission	$\pm 2.02\text{dB}$
Radiated Emission	Below 1GHz $\pm 3.8\text{ dB}$
	Above 1GHz $\pm 3.9\text{ dB}$
RF Antenna Port Conducted Emission	$\pm 1.27\text{dB}$
Radiated Emission Band Edge	$\pm 3.9\text{dB}$
Occupied Bandwidth	$\pm 1\text{kHz}$
Power Spectral Density	$\pm 1.27\text{dB}$

3. AC Power Line Conducted Emission

3.1. Test Equipment

AC Power Line Conducted Emission / TR-1					
Instrument	Manufacturer	Type No.	Serial No.	Cal. Date	Cal. Due Date
EMI Test Receiver	R&S	ESCI	100906	2019.03.05	2020.03.04
Two-Line V-Network	R&S	ENV 216	101189	2018.07.16	2019.07.15
Two-Line V-Network	R&S	ENV 216	101044	2018.09.16	2019.09.15
50ohm Coaxial Switch	Anritsu	MP59B	6200464462	N/A	N/A
50ohm Termination	SHX	TF2	07081402	2018.09.16	2019.09.15
Temperature/Humidity Meter	Zhichen	ZC1-2	TR1-TH	2019.01.05	2020.01.04

Note: All equipments are calibrated with traceable calibrations. Each calibration is traceable to the national or international standards.

3.2. Test Setup

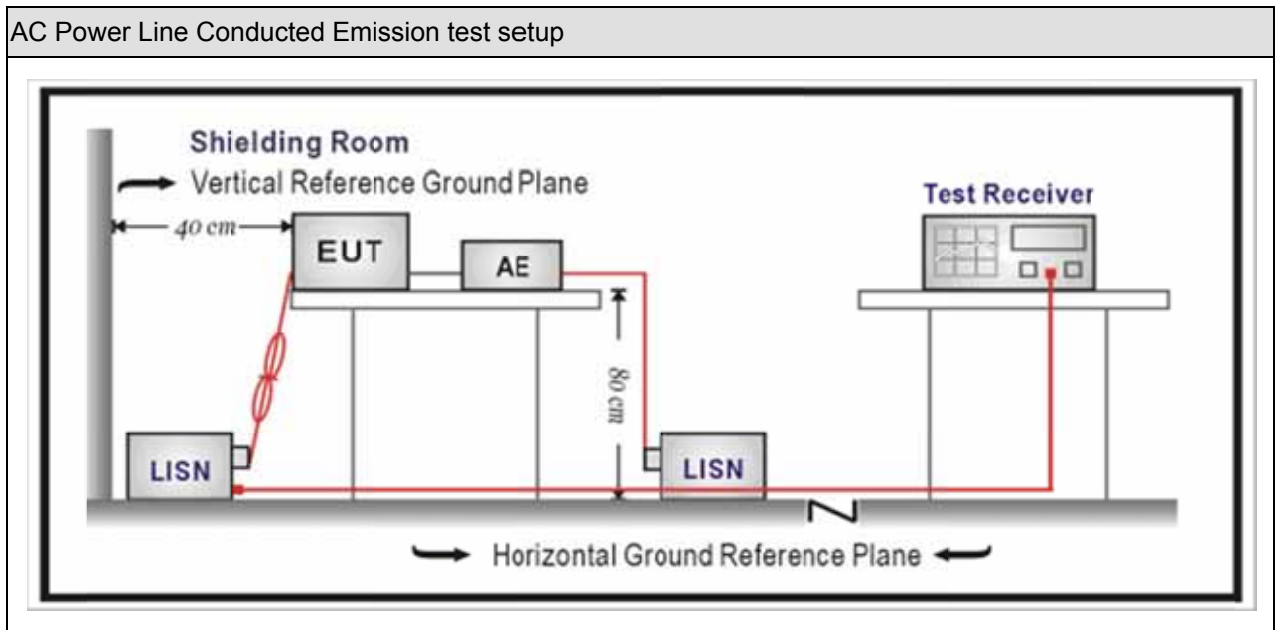

3.3. Limit

Frequency of Emission (MHz)	Conducted Limit	
	Quasi-peak (dB μ V)	Average (dB μ V)
0.15-0.5	66 to 56	56 to 46
0.5-5	56	46
5-30	60	50

Note 1: The lower limit shall apply at the transition frequencies.
 Note 2: The limit decreases linearly with the logarithm of the frequency in the range 0.15 MHz to 0.5 MHz.

3.4. Test Procedure

Test Method			
	References Rule	Chapter	Item
<input checked="" type="checkbox"/>	ANSI C63.10-2013	6.2	Standard test method for ac power-line conducted emissions from unlicensed wireless devices
<input checked="" type="checkbox"/>	ANSI C63.4-2014	7	AC power-line conducted emission measurements

3.5. Test Result

Engineer: LiuYu	
Site: TR1	Time: 2019/04/13 - 11:10
Limit: FCC_Part15.107_CE_AC Power_ClassB	Margin: 4
Probe: ENV216_101190(0.009-30MHz)	Polarity: Neutral
EUT: LED LAMP	Power: AC 120V/60Hz
Note: Mode 1	

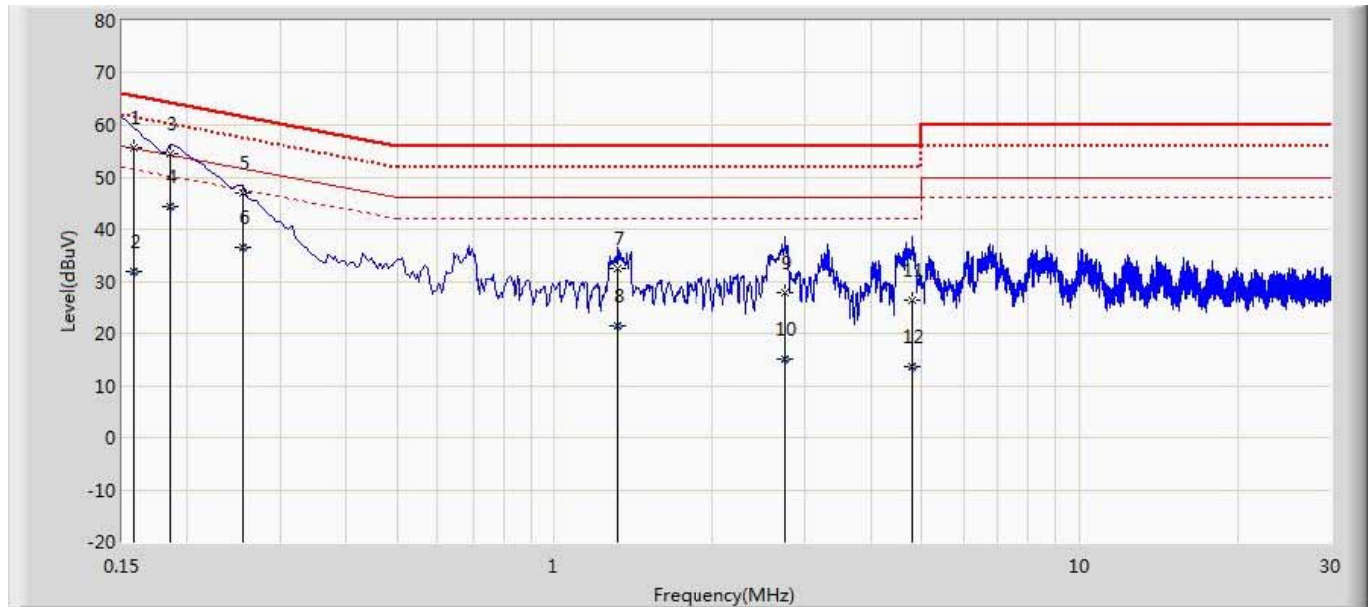

No	Mark	Frequency (MHz)	Measure Level (dBuV)	Reading Level (dBuV)	Over Limit (dB)	Limit (dBuV)	Factor (dB)	Type
1		0.158	55.508	45.893	-10.079	65.587	9.614	QP
2		0.158	31.879	22.265	-23.708	55.587	9.614	AV
3	*	0.186	54.469	44.845	-9.744	64.213	9.624	QP
4		0.186	44.453	34.829	-9.760	54.213	9.624	AV
5		0.254	46.940	37.311	-14.685	61.625	9.629	QP
6		0.254	36.519	26.890	-15.106	51.625	9.629	AV
7		1.318	32.328	22.664	-23.672	56.000	9.664	QP
8		1.318	21.565	11.901	-24.435	46.000	9.664	AV
9		2.746	27.902	18.175	-28.098	56.000	9.727	QP
10		2.746	15.101	5.374	-30.899	46.000	9.727	AV
11		4.786	26.362	16.574	-29.638	56.000	9.788	QP
12		4.786	13.521	3.733	-32.479	46.000	9.788	AV

Note:

1. " * ", means this data is the worst emission level.
2. Measurement Level = Reading Level + Factor(Probe+Cable-Amp).

Engineer: LiuYu	
Site: TR1	Time: 2019/04/13 - 13:03
Limit: FCC_Part15.107_CE_AC Power_ClassB	Margin: 4
Probe: ENV216_101190(0.009-30MHz)	Polarity: Line
EUT: LED LAMP	Power: AC 120V/60Hz
Note: Mode 1	

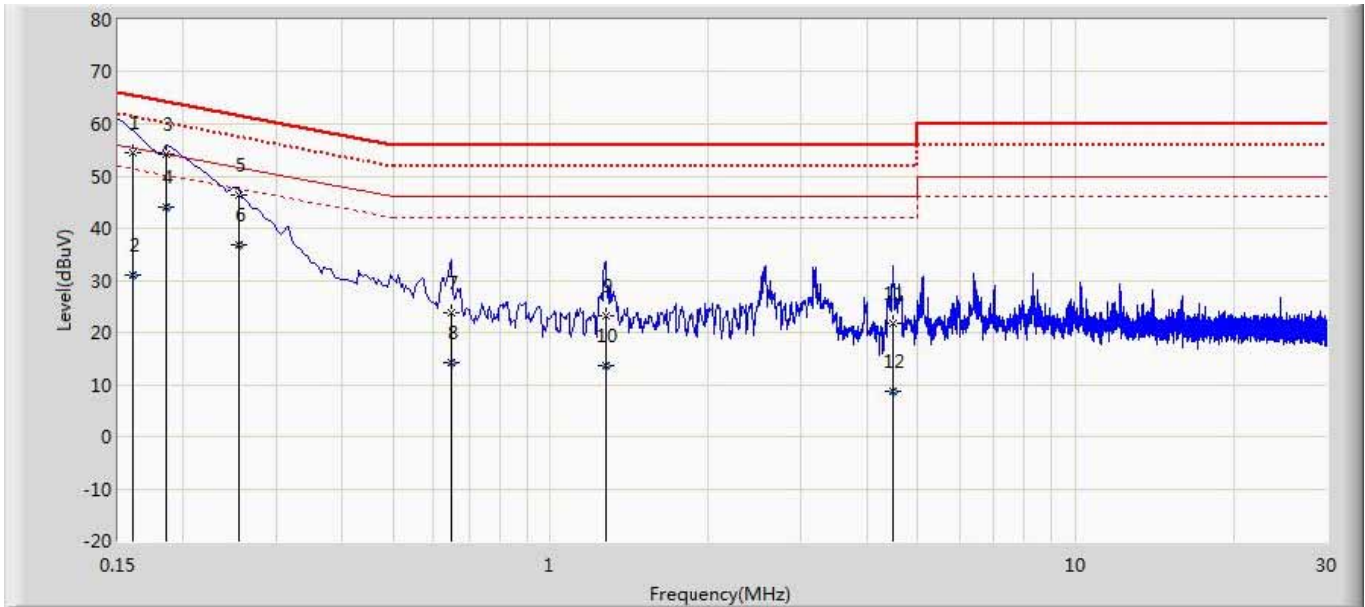

No	Mark	Frequency (MHz)	Measure Level (dBuV)	Reading Level (dBuV)	Over Limit (dB)	Limit (dBuV)	Factor (dB)	Type
1		0.160	54.519	44.888	-10.930	65.449	9.630	QP
2		0.160	30.974	21.343	-24.475	55.449	9.630	AV
3	*	0.186	54.175	44.546	-10.038	64.213	9.630	QP
4		0.186	44.087	34.458	-10.127	54.213	9.630	AV
5		0.254	46.452	36.821	-15.173	61.625	9.631	QP
6		0.254	36.732	27.102	-14.893	51.625	9.631	AV
7		0.650	23.755	14.108	-32.245	56.000	9.647	QP
8		0.650	14.292	4.645	-31.708	46.000	9.647	AV
9		1.274	23.123	13.449	-32.877	56.000	9.674	QP
10		1.274	13.486	3.812	-32.514	46.000	9.674	AV
11		4.482	21.705	11.920	-34.295	56.000	9.784	QP
12		4.482	8.661	-1.124	-37.339	46.000	9.784	AV

Note:

1. " * ", means this data is the worst emission level.
2. Measurement Level = Reading Level + Factor(Probe+Cable-Amp).

4. Emissions in restricted frequency bands

4.1. Test Equipment

Radiated Emission(Below 1GHz) / AC-2					
Instrument	Manufacturer	Type No.	Serial No.	Cal. Date	Cal. Due Date
EMI Test Receiver	R&S	ESCI	100573	2019.03.29	2020.03.28
Loop Antenna	R&S	HFH2-Z2	833799/003	2018.11.16	2019.11.15
Bilog Antenna	Teseq GmbH	CBL6112D	27611	2018.10.16	2019.10.15
Coaxial Cable	Huber+Suhner	SUCOFLEX 106	AC2-C	2019.03.02	2020.03.01
Temperature/Humidity Meter	Zhichen	ZC1-2	AC2-TH	2019.01.04	2020.01.03
Note: All equipments are calibrated with traceable calibrations. Each calibration is traceable to the national or international standards.					

Radiated Emission(Above 1GHz) / AC-5					
Instrument	Manufacturer	Type No.	Serial No.	Cal. Date	Cal. Due Date
Spectrum Analyzer	Agilent	E4446A	MY45300103	2019.01.04	2020.01.03
Preamplifier	Miteq	NSP1800-25	1364185	2018.05.06	2019.05.05
Preamplifier	QuieTek	AP-040G	CHM-0906001	2018.05.06	2019.05.05
DRG Horn	ETS-Lindgren	3117	00123988	2019.01.22	2020.01.21
Broad-Band Horn Antenna	Schwarzbeck	BBHA9170	294	2018.11.25	2019.11.24
Coaxial Cable	Huber+Suhner	SUCOFLEX 106	AC5-C1	2019.03.02	2020.03.01
Coaxial Cable	Huber+Suhner	SUCOFLEX 106	AC5-C2	2019.03.02	2020.03.01
Coaxial Cable	Huber+Suhner	SUCOFLEX 102	AC5-C3	2019.03.02	2020.03.01
EMI Receiver	Agilent	N9038A	MY51210196	2018.06.10	2019.06.09
Temperature/Humidity Meter	Zhichen	ZC1-2	AC5-TH	2019.01.04	2020.01.03
Note: All equipments are calibrated with traceable calibrations. Each calibration is traceable to the national or international standards.					

4.2. Test Setup

Below 30MHz Test Setup:

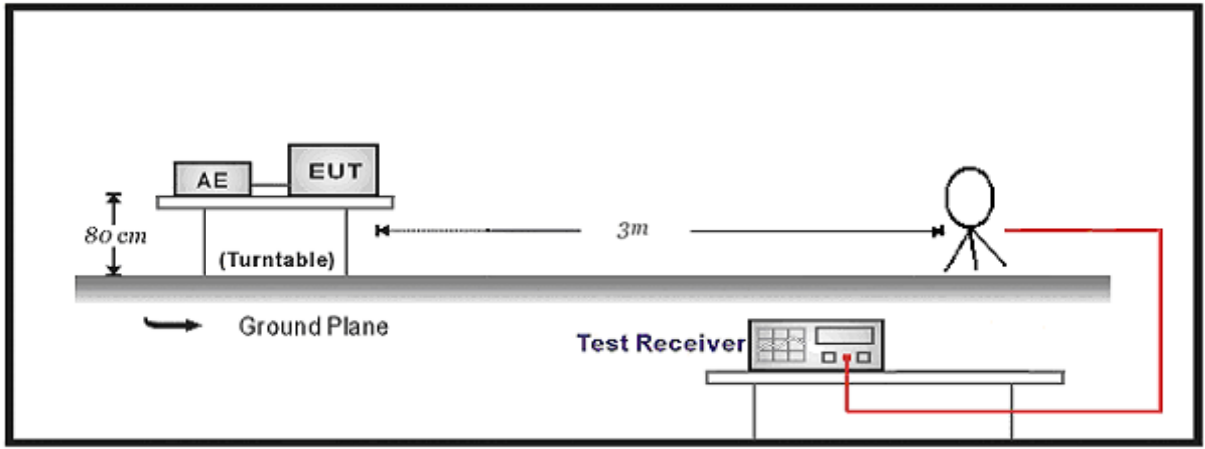

30MHz-1GHz Test Setup:

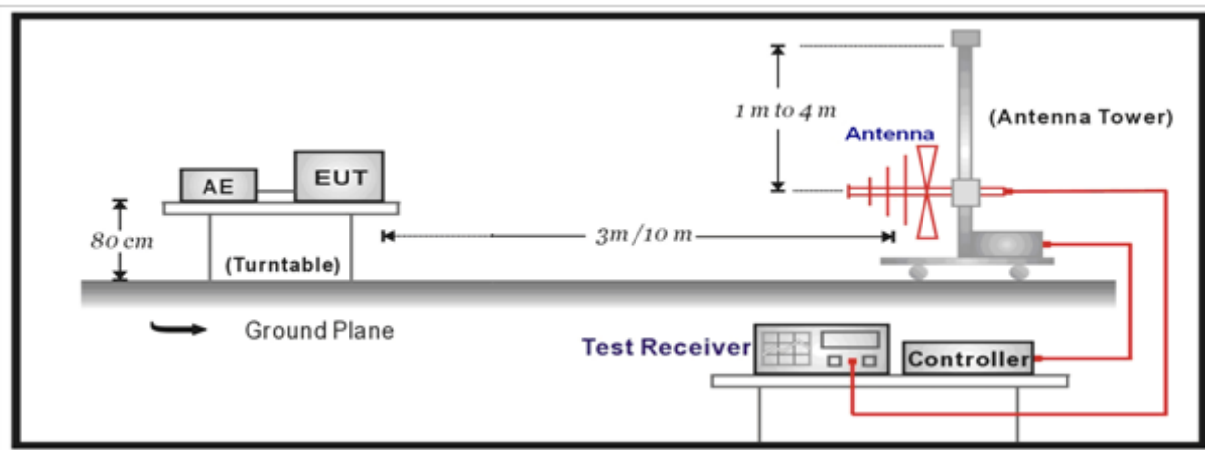

Above 1GHz Test Setup:

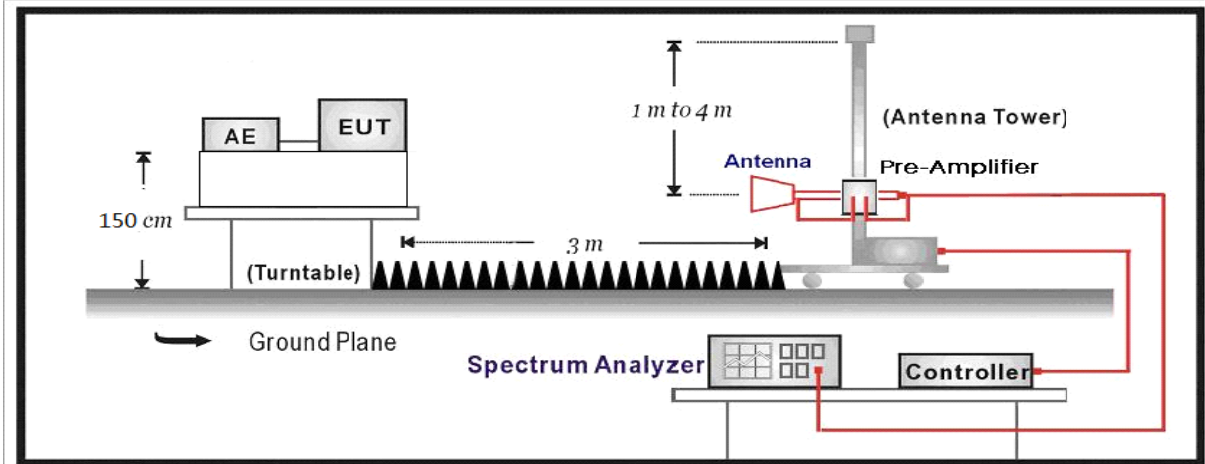

4.3. Limit

For FCC:

Restricted Bands of operation			
Frequency (MHz)	Frequency (MHz)	Frequency (MHz)	Frequency (GHz)
0.090 – 0.110	16.42 – 16.423	399.9 – 410	4.5 – 5.15
0.495 – 0.505	16.69475 – 16.69525	608 – 614	5.35 – 5.46
2.1735 – 2.1905	16.80425 – 16.80475	960 – 1240	7.25 – 7.75
4.125 – 4.128	25.5 – 25.67	1300 – 1427	8.025 – 8.5
4.17725 – 4.17775	37.5 – 38.25	1435 – 1626.5	9.0 – 9.2
4.20725 – 4.20775	73 – 74.6	1645.5 – 1646.5	9.3 – 9.5
6.215 – 6.218	74.8 – 75.2	1660 – 1710	10.6 – 12.7
6.26775 – 6.26825	108 – 121.94	1718.8 – 1722.2	13.25 – 13.4
6.31175 – 6.31225	123 – 138	2200 – 2300	14.47 – 14.5
8.291 – 8.294	149.9 – 150.05	2310 – 2390	15.35 – 16.2
8.362 – 8.366	156.52475 – 156.52525	2483.5 – 2500	17.7 – 21.4
8.37625 – 8.38675	156.7 – 156.9	2690 – 2900	22.01 – 23.12
8.81425 – 8.81475	162.0125 – 167.17	3260 – 3267	23.6 – 24.0
12.29 – 12.293	167.72 – 173.2	3332 – 3339	31.2 – 31.8
12.51975 – 12.52025	240 – 285	3345.8 – 3358	36.43 – 36.5
12.57675 – 12.57725	322 – 335.4	3600 – 4400	
13.36 – 13.41			

For ISED:

Restricted Bands of operation			
Frequency (MHz)	Frequency (MHz)	Frequency (MHz)	Frequency (GHz)
	13.36 - 13.41	960 - 1427	9.0 - 9.2
0.495 - 0.505	16.42 - 16.423	1435 - 1626.5	9.3 - 9.5
2.1735 - 2.1905	16.69475 - 16.69525	1645.5 - 1646.5	10.6 - 12.7
3.020 - 3.026	16.80425 - 16.80475	1660 - 1710	13.25 - 13.4
4.125 - 4.128	25.5 - 25.67	1718.8 - 1722.2	14.47 - 14.5
4.17725 - 4.17775	37.5 - 38.25	2200 - 2300	15.35 - 16.2
4.20725 - 4.20775	73 - 74.6	2310 - 2390	17.7 - 21.4
5.677 - 5.683	74.8 - 75.2	2483.5 - 2500	22.01 - 23.12
6.215 - 6.218	108 - 138	2655 - 2900	23.6 - 24.0
6.26775 - 6.26825	149.9 - 150.05	3260 - 3267	31.2 - 31.8
6.31175 - 6.31225	156.52475 - 156.52525	3332 - 3339	36.43 - 36.5
8.291 - 8.294	156.7 - 156.9	3345.8 - 3358	Above 38.6
8.362 - 8.366	162.0125 - 167.17	3500 - 4400	
8.37625 - 8.38675	167.72 - 173.2	4500 - 5150	
8.41425 - 8.41475	240 - 285	5350 - 5460	
12.29 - 12.293	322 - 335.4	7250 - 7750	
12.51975 - 12.52025	399.9 - 410	8025 - 8500	
12.57675 - 12.57725	608 - 614	--	

Restricted Band Emissions Limit			
Frequency (MHz)	Field strength (μ V/m)	Field strength (dB μ V/m)	Measurement distance (m)
0.009 - 0.49	2400/F(kHz)	48.5 – 13.8	300 _(Note 1)
0.49 - 1.705	24000/F(kHz)	33.8 - 23	30 _(Note 1)
1.705 - 30	30	29.5	30 _(Note 1)
30 - 88	100	40	3 _(Note 2)
88 - 216	150	43.5	3 _(Note 2)
216 - 960	200	46	3 _(Note 2)
Above 960	500	54	3 _(Note 2)



Note 1: At frequencies below 30 MHz, measurements may be performed at a distance closer than that specified in the regulations; however, an attempt should be made to avoid making measurements in the near field. Pending the development of an appropriate measurement procedure for measurements performed below 30 MHz, when performing measurements at a closer distance than specified, the results shall be extrapolated to the specified distance by either making measurements at a minimum of two distances on at least one radial to determine the proper extrapolation factor or by using the square of an inverse linear distance extrapolation factor (40 dB/decade).

Note 2: At frequencies at or above 30 MHz, measurements may be performed at a distance other than what is specified provided: measurements are not made in the near field except where it can be shown that near field measurements are appropriate due to the characteristics of the device; and it can be demonstrated that the signal levels needed to be measured at the distance employed can be detected by the measurement equipment. Measurements shall not be performed at a distance greater than 30 meters unless it can be further demonstrated that measurements at a distance of 30 meters or less are impractical. When performing measurements at a distance other than that specified, the results shall be extrapolated to the specified distance using an extrapolation factor of 20 dB/decade (inverse linear-distance for field strength measurements; inverse-linear-distance-squared for power density measurements).

4.4. Test Procedure

Test Method			
	References Rule	Chapter	Description
<input type="checkbox"/>	ANSI C63.10	11.11	Emissions in non-restricted frequency bands
	<input type="checkbox"/> ANSI C63.10	11.11.2	Reference level measurement
	<input type="checkbox"/> ANSI C63.10	11.11.3	Emission level measurement
<input checked="" type="checkbox"/>	ANSI C63.10	11.12	Emissions in restricted frequency bands
	<input checked="" type="checkbox"/> ANSI C63.10	11.12.1	Radiated emission measurements
	<input checked="" type="checkbox"/> ANSI C63.10	11.12.2.7	Radiated spurious emission test
	<input checked="" type="checkbox"/> ANSI C63.10	6.4	Radiated emissions from unlicensed wireless devices below 30 MHz
	<input checked="" type="checkbox"/> ANSI C63.10	6.5	Radiated emissions from unlicensed wireless devices in the frequency range of 30 MHz to 1000 MHz
	<input checked="" type="checkbox"/> ANSI C63.10	6.6	Radiated emissions from unlicensed wireless devices above 1 GHz
	<input type="checkbox"/> ANSI C63.10	11.12.2.3	Quasi-peak measurement procedure
	<input type="checkbox"/> ANSI C63.10	11.12.2.4	Peak power measurement procedure
	<input type="checkbox"/> ANSI C63.10	11.12.2.5	Average power measurement procedures
	<input type="checkbox"/> ANSI C63.10	11.12.2.5.1	Trace averaging with continuous EUT transmission at full power
	<input type="checkbox"/> ANSI C63.10	11.12.2.5.2	Trace averaging across ON and OFF times of the EUT transmissions followed by duty cycle correction
	<input type="checkbox"/> ANSI C63.10	11.12.2.5.3	Reduced VBW averaging across ON and OFF times of the EUT transmissions with max hold

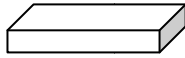
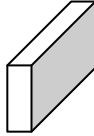
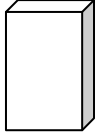
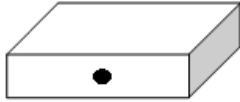
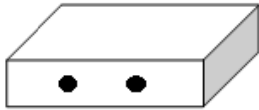
4.5. EUT test Axis definition

Item	Emissions in restricted frequency bands			
Device Category	<input type="checkbox"/>	Fixed point-to-point		
	<input type="checkbox"/>	Emit multiple directional beams, simultaneously or sequentially		
	<input checked="" type="checkbox"/>	Other cases		
Test mode	Mode 1			
Test method	<input checked="" type="checkbox"/>	Radiated		
		X Axis	Y Axis	Z Axis
				
		Worst Axis <input checked="" type="checkbox"/>	Worst Axis <input type="checkbox"/>	Worst Axis <input type="checkbox"/>
	<input type="checkbox"/>	Conducted		
	<input type="checkbox"/>	Chain 0		
				
	<input type="checkbox"/>	Chain 0	Chain 1	
				
	<input type="checkbox"/>	Chain 0	Chain 1	Chain 2
				

4.6. Test Result

Muruta:

Engineer: YULIU	
Site: AC5	Time: 2019/04/10 - 22:56
Limit: FCC_Part15.209_RE(3m)	Margin: 0
Probe: Horn_3117_00167055(1-18GHz)	Polarity: Vertical
EUT: LED LAMP	Power: AC 120V/60Hz
Note: Mode1:Transmit at 2402Mhz by Zigbee	

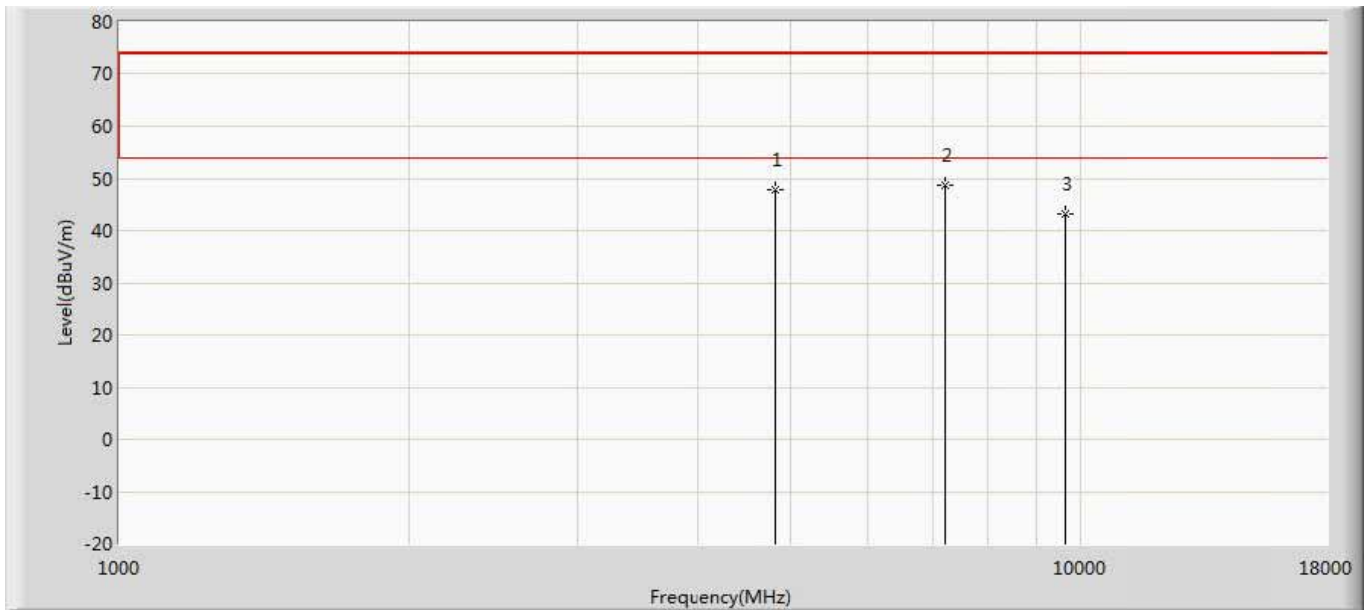

No	Mark	Frequency (MHz)	Measure Level (dBuV/m)	Reading Level (dBuV)	Over Limit (dB)	Limit (dBuV/m)	Factor (dB)	Type
1		4808.000	47.702	49.503	-26.298	74.000	-1.801	PK
2	*	7213.500	48.557	46.765	-25.443	74.000	1.792	PK
3		9620.000	43.211	39.103	-30.789	74.000	4.108	PK

Engineer: YULIU	
Site: AC5	Time: 2019/04/10 - 22:56
Limit: FCC_Part15.209_RE(3m)	Margin: 0
Probe: Horn_3117_00167055(1-18GHz)	Polarity: Horizontal
EUT: LED LAMP	Power: AC 120V/60Hz
Note: Mode1:Transmit at 2402Mhz by Zigbee	

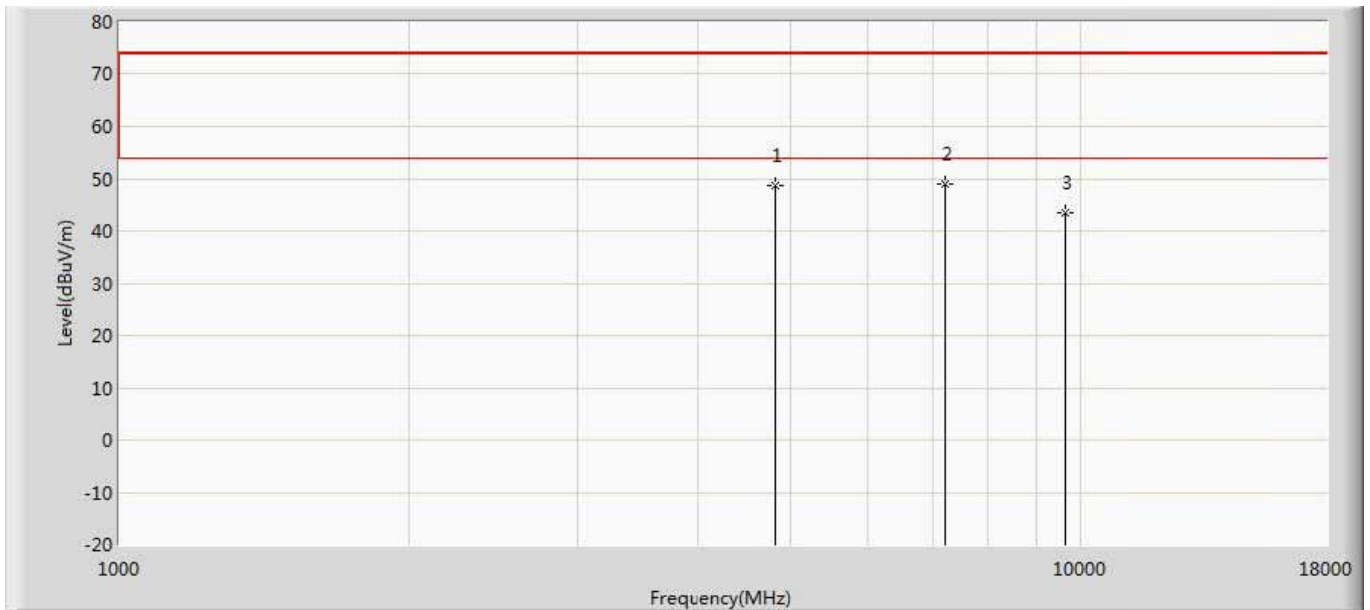

No	Mark	Frequency (MHz)	Measure Level (dBuV/m)	Reading Level (dBuV)	Over Limit (dB)	Limit (dBuV/m)	Factor (dB)	Type
1		4808.000	48.647	50.448	-25.353	74.000	-1.801	PK
2	*	7213.500	49.088	47.296	-24.912	74.000	1.792	PK
3		9620.000	43.554	39.446	-30.446	74.000	4.108	PK

Engineer: YULIU	
Site: AC5	Time: 2019/04/10 - 22:56
Limit: FCC_Part15.209_RE(3m)	Margin: 0
Probe: Horn_3117_00167055(1-18GHz)	Polarity: Vertical
EUT: LED LAMP	Power: AC 120V/60Hz
Note: Mode1:Transmit at 2440Mhz by Zigbee	

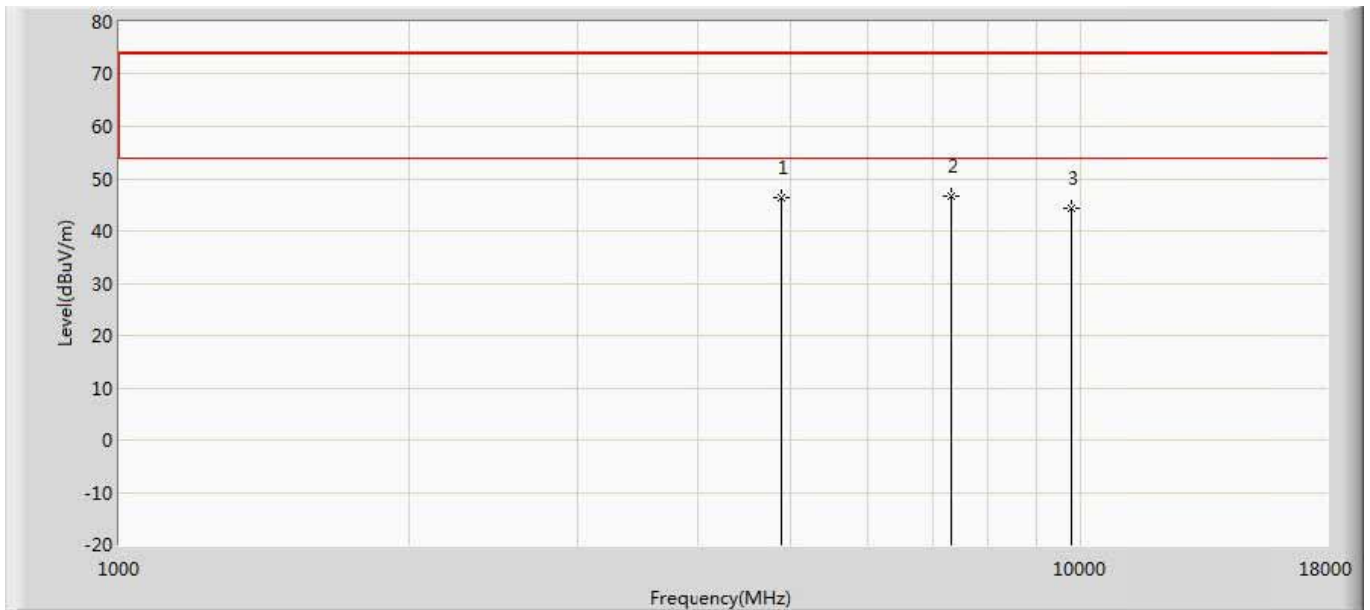

No	Mark	Frequency (MHz)	Measure Level (dBuV/m)	Reading Level (dBuV)	Over Limit (dB)	Limit (dBuV/m)	Factor (dB)	Type
1		4876.000	46.360	47.579	-27.640	74.000	-1.219	PK
2	*	7324.000	46.674	44.757	-27.326	74.000	1.917	PK
3		9760.000	44.478	38.666	-29.522	74.000	5.812	PK

Engineer: YULIU	
Site: AC5	Time: 2019/04/10 - 22:57
Limit: FCC_Part15.209_RE(3m)	Margin: 0
Probe: Horn_3117_00167055(1-18GHz)	Polarity: Horizontal
EUT: LED LAMP	Power: AC 120V/60Hz
Note: Mode1:Transmit at 2440Mhz by Zigbee	

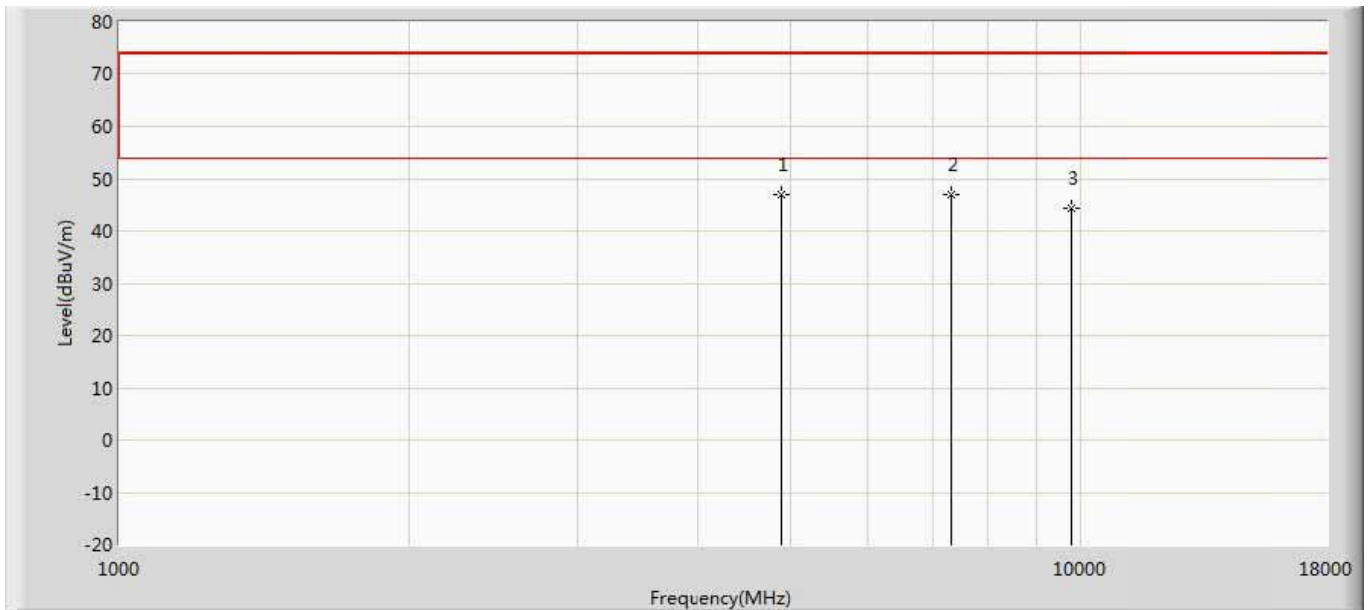

No	Mark	Frequency (MHz)	Measure Level (dBuV/m)	Reading Level (dBuV)	Over Limit (dB)	Limit (dBuV/m)	Factor (dB)	Type
1		4876.000	46.895	48.114	-27.105	74.000	-1.219	PK
2	*	7315.500	47.004	45.159	-26.996	74.000	1.845	PK
3		9760.000	44.289	38.477	-29.711	74.000	5.812	PK

Engineer: YULIU	
Site: AC5	Time: 2019/04/10 - 22:57
Limit: FCC_Part15.209_RE(3m)	Margin: 0
Probe: Horn_3117_00167055(1-18GHz)	Polarity: Vertical
EUT: LED LAMP	Power: AC 120V/60Hz
Note: Mode1:Transmit at 2480Mhz by Zigbee	

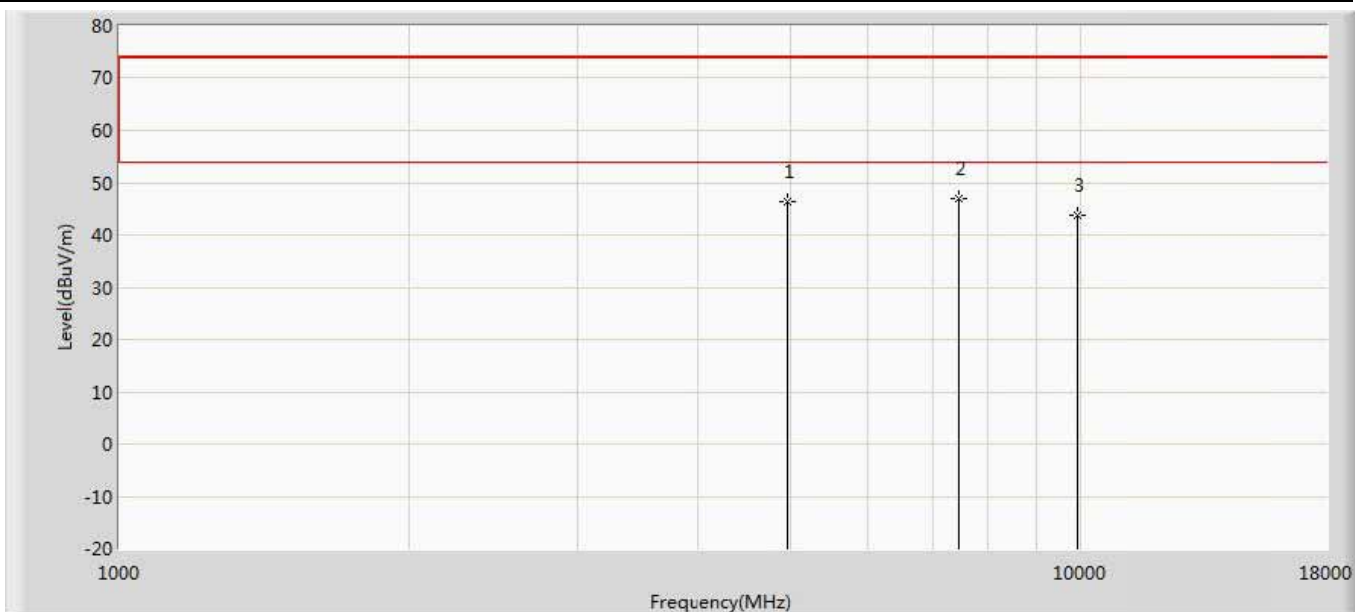

No	Mark	Frequency (MHz)	Measure Level (dBuV/m)	Reading Level (dBuV)	Over Limit (dB)	Limit (dBuV/m)	Factor (dB)	Type
1		4961.000	46.307	47.463	-27.693	74.000	-1.156	PK
2	*	7443.000	46.837	44.348	-27.163	74.000	2.489	PK
3		9920.000	43.787	38.533	-30.213	74.000	5.253	PK

Engineer: YULIU	
Site: AC5	Time: 2019/04/10 - 22:57
Limit: FCC_Part15.209_RE(3m)	Margin: 0
Probe: Horn_3117_00167055(1-18GHz)	Polarity: Horizontal
EUT: LED LAMP	Power: AC 120V/60Hz
Note: Mode1:Transmit at 2480Mhz by Zigbee	

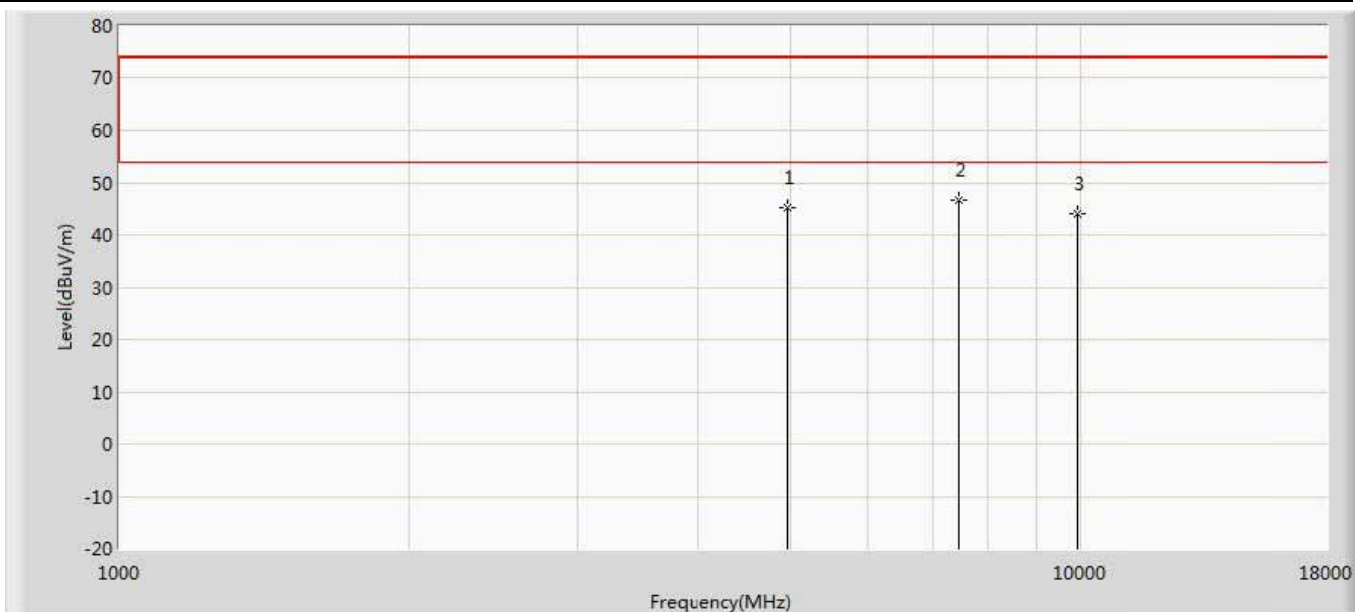

No	Mark	Frequency (MHz)	Measure Level (dBuV/m)	Reading Level (dBuV)	Over Limit (dB)	Limit (dBuV/m)	Factor (dB)	Type
1		4961.000	45.220	46.376	-28.780	74.000	-1.156	PK
2	*	7443.000	46.636	44.147	-27.364	74.000	2.489	PK
3		9920.000	44.010	38.756	-29.990	74.000	5.253	PK

Diodes:

Engineer: YULIU	
Site: AC5	Time: 2019/04/10 - 23:04
Limit: FCC_Part15.209_RE(3m)	Margin: 0
Probe: Horn_3117_00167055(1-18GHz)	Polarity: Vertical
EUT: LED LAMP	Power: AC 120V/60Hz
Note: Mode 1:Transmit at 2405Mhz by Zigbee	

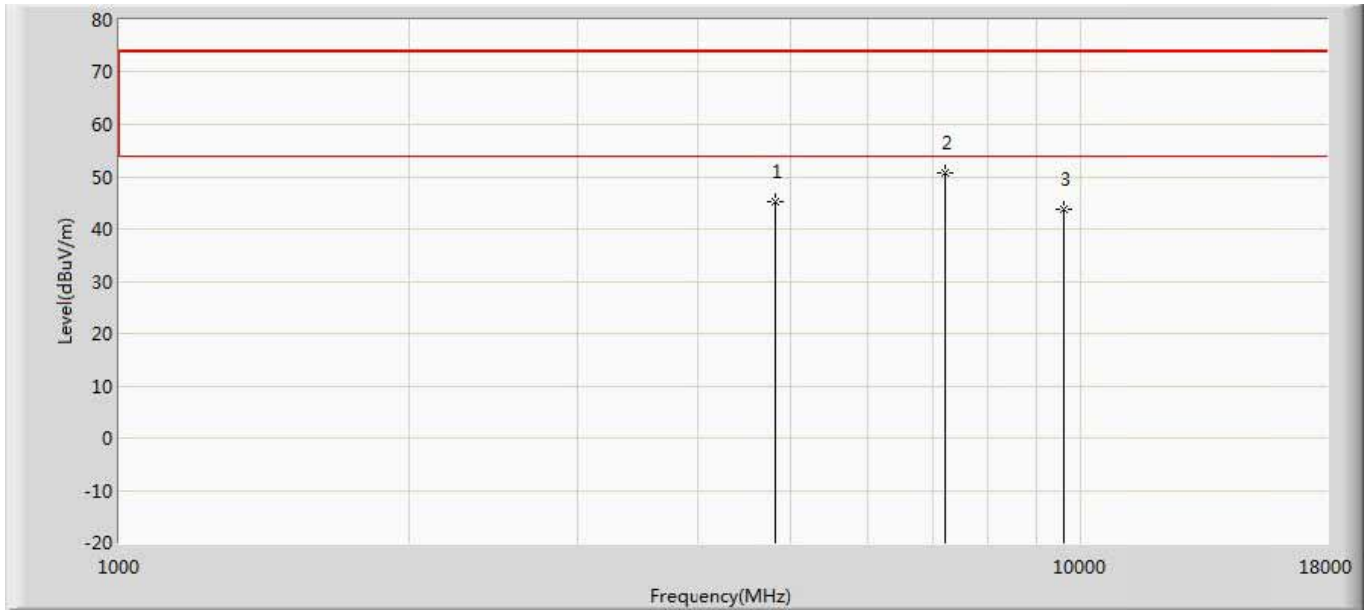

No	Mark	Frequency (MHz)	Measure Level (dBuV/m)	Reading Level (dBuV)	Over Limit (dB)	Limit (dBuV/m)	Factor (dB)	Type
1		4808.000	45.211	47.012	-28.789	74.000	-1.801	PK
2	*	7213.500	50.664	48.872	-23.336	74.000	1.792	PK
3		9608.000	43.751	38.852	-30.249	74.000	4.899	PK

Engineer: YULIU	
Site: AC5	Time: 2019/04/10 - 23:04
Limit: FCC_Part15.209_RE(3m)	Margin: 0
Probe: Horn_3117_00167055(1-18GHz)	Polarity: Horizontal
EUT: LED LAMP	Power: AC 120V/60Hz
Note: Mode 1:Transmit at 2405Mhz by Zigbee	

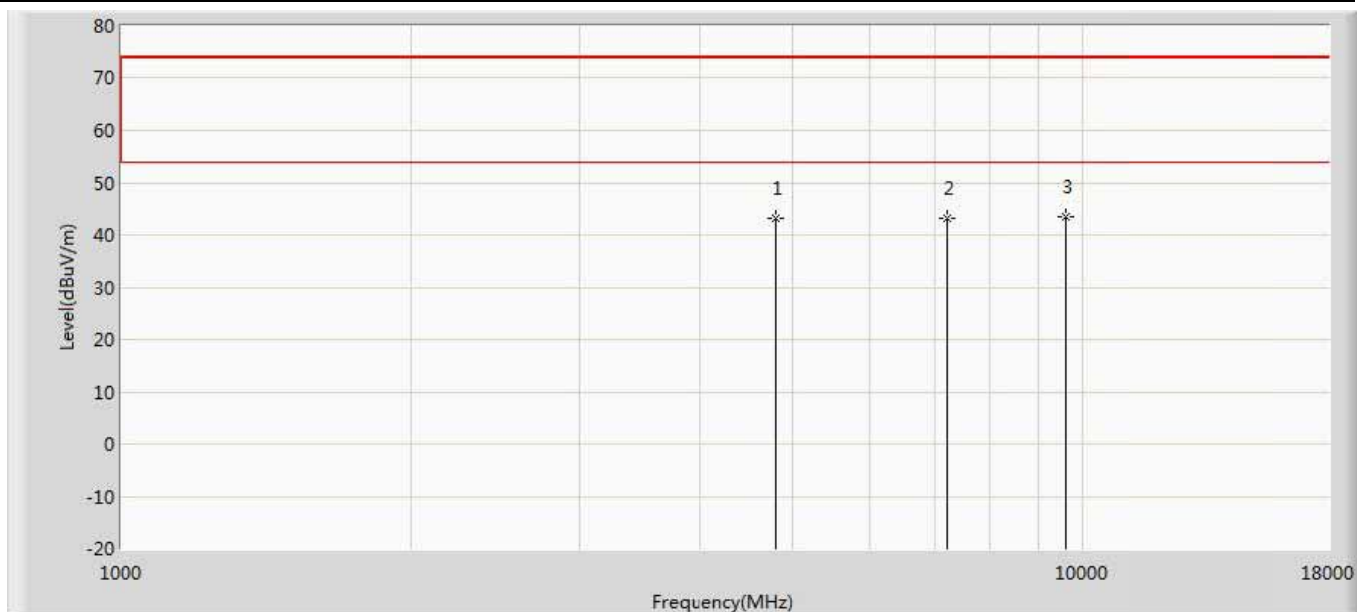

No	Mark	Frequency (MHz)	Measure Level (dBuV/m)	Reading Level (dBuV)	Over Limit (dB)	Limit (dBuV/m)	Factor (dB)	Type
1		4804.000	43.319	45.042	-30.681	74.000	-1.723	PK
2		7206.000	43.114	41.195	-30.886	74.000	1.919	PK
3	*	9608.000	43.496	38.597	-30.504	74.000	4.899	PK

Engineer: YULIU	
Site: AC5	Time: 2019/04/10 - 23:04
Limit: FCC_Part15.209_RE(3m)	Margin: 0
Probe: Horn_3117_00167055(1-18GHz)	Polarity: Vertical
EUT: LED LAMP	Power: AC 120V/60Hz
Note: Mode 1:Transmit at 2440Mhz by Zigbee	

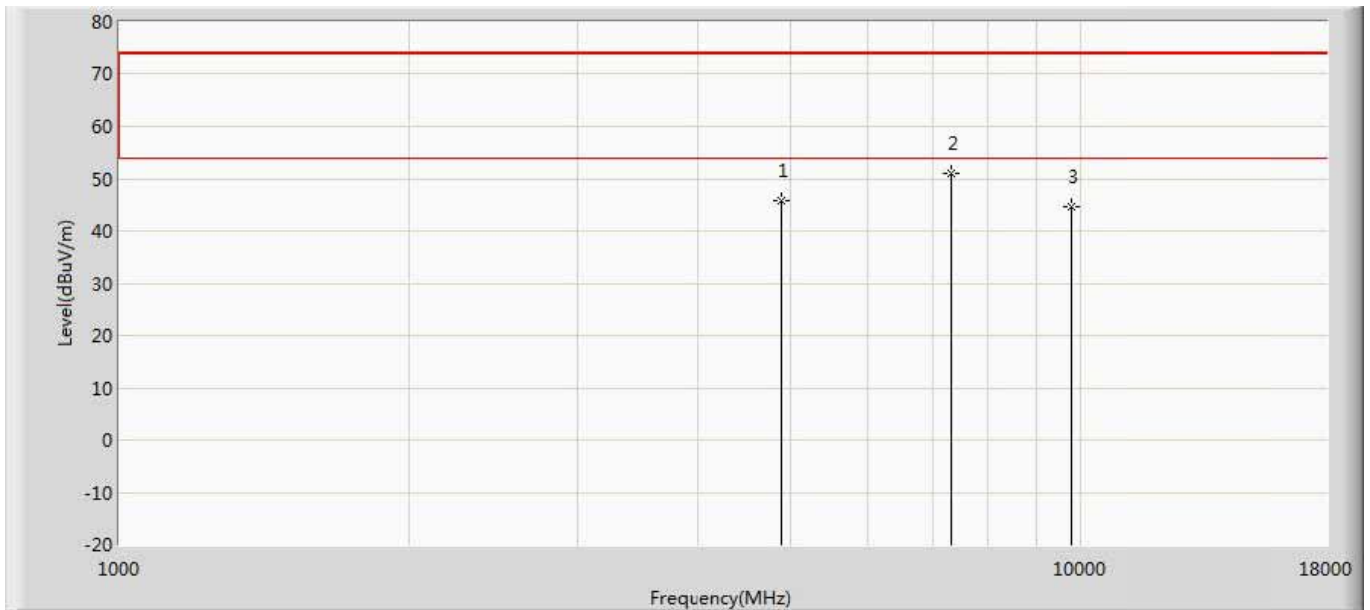

No	Mark	Frequency (MHz)	Measure Level (dBuV/m)	Reading Level (dBuV)	Over Limit (dB)	Limit (dBuV/m)	Factor (dB)	Type
1		4884.500	45.878	47.236	-28.122	74.000	-1.358	PK
2	*	7324.000	50.961	49.044	-23.039	74.000	1.917	PK
3		9760.000	44.649	38.837	-29.351	74.000	5.812	PK

Engineer: YULIU	
Site: AC5	Time: 2019/04/10 - 23:04
Limit: FCC_Part15.209_RE(3m)	Margin: 0
Probe: Horn_3117_00167055(1-18GHz)	Polarity: Horizontal
EUT: LED LAMP	Power: AC 120V/60Hz
Note: Mode 1:Transmit at 2440Mhz by Zigbee	

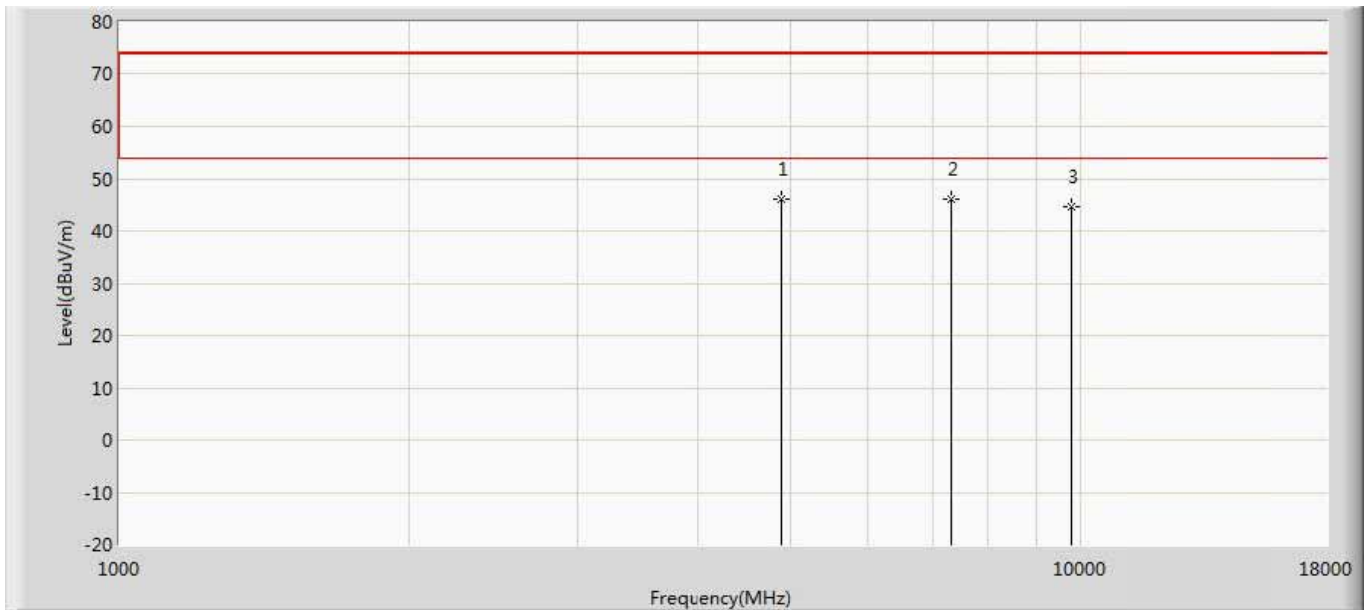

No	Mark	Frequency (MHz)	Measure Level (dBuV/m)	Reading Level (dBuV)	Over Limit (dB)	Limit (dBuV/m)	Factor (dB)	Type
1		4884.500	46.000	47.358	-28.000	74.000	-1.358	PK
2	*	7315.500	46.173	44.328	-27.827	74.000	1.845	PK
3		9760.000	44.634	38.822	-29.366	74.000	5.812	PK

Engineer: YULIU	
Site: AC5	Time: 2019/04/10 - 23:04
Limit: FCC_Part15.209_RE(3m)	Margin: 0
Probe: Horn_3117_00167055(1-18GHz)	Polarity: Vertical
EUT: LED LAMP	Power: AC 120V/60Hz
Note: Mode 1:Transmit at 2480Mhz by Zigbee	

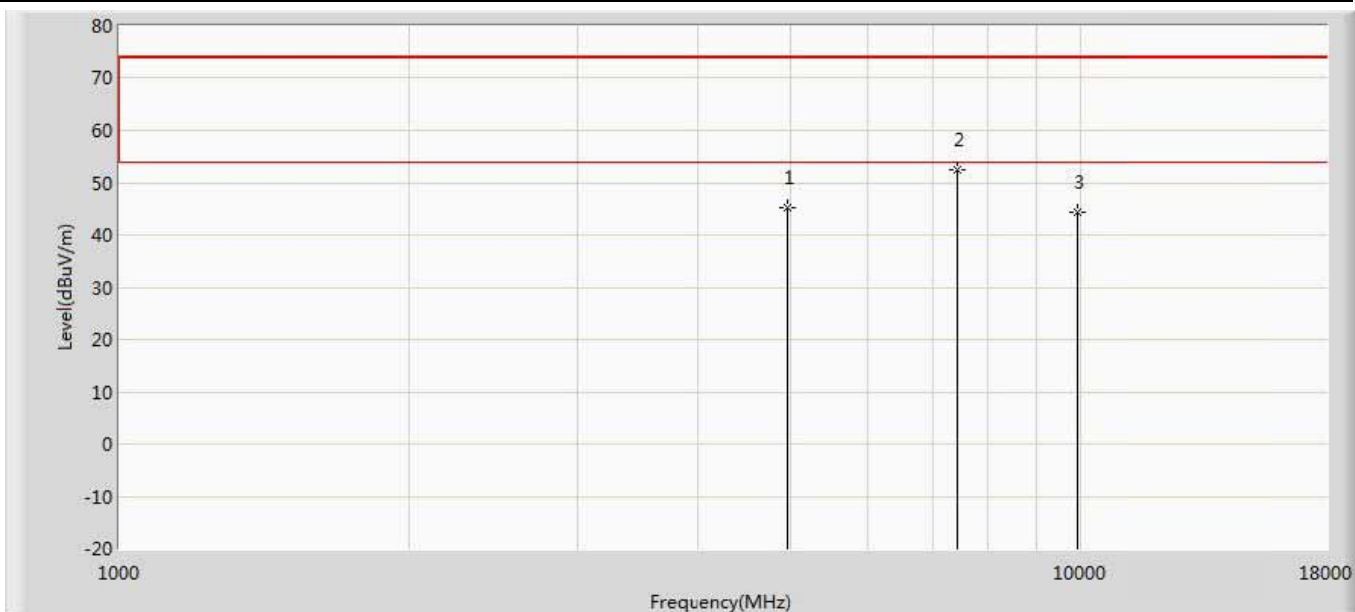

No	Mark	Frequency (MHz)	Measure Level (dBuV/m)	Reading Level (dBuV)	Over Limit (dB)	Limit (dBuV/m)	Factor (dB)	Type
1		4961.000	45.296	46.452	-28.704	74.000	-1.156	PK
2	*	7434.500	52.473	50.165	-21.527	74.000	2.308	PK
3		9920.000	44.374	39.120	-29.626	74.000	5.253	PK

Engineer: YULIU	
Site: AC5	Time: 2019/04/10 - 23:04
Limit: FCC_Part15.209_RE(3m)	Margin: 0
Probe: Horn_3117_00167055(1-18GHz)	Polarity: Horizontal
EUT: LED LAMP	Power: AC 120V/60Hz
Note: Mode 1:Transmit at 2480Mhz by Zigbee	

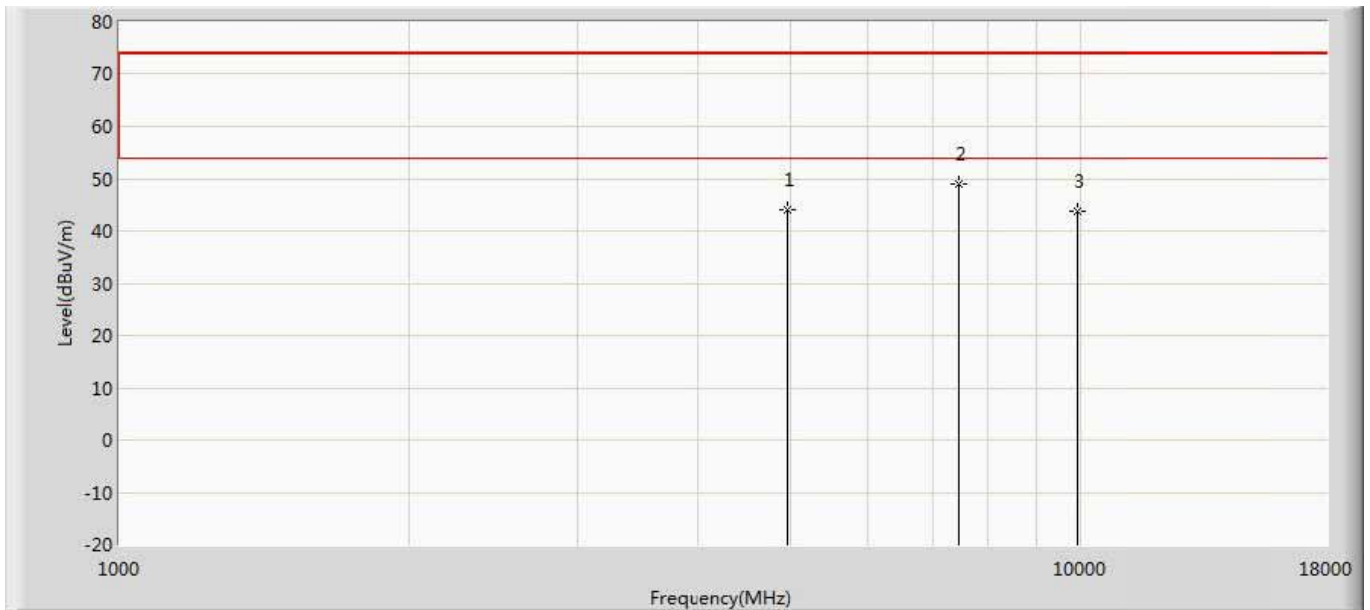

No	Mark	Frequency (MHz)	Measure Level (dBuV/m)	Reading Level (dBuV)	Over Limit (dB)	Limit (dBuV/m)	Factor (dB)	Type
1		4960.000	44.156	45.304	-29.844	74.000	-1.148	PK
2	*	7443.000	49.063	46.574	-24.937	74.000	2.489	PK
3		9920.000	43.834	38.580	-30.166	74.000	5.253	PK

Kdx:

Engineer: YULIU	
Site: AC5	Time: 2019/04/15 - 10:13
Limit: FCC_Part15.209_RE(3m)	Margin: 0
Probe: Horn_3117_00167055(1-18GHz)	Polarity: Vertical
EUT:LED LAMP	Power: AC 120V/60Hz
Note: Mode1:Transmit at 2405MHz by Zigbee	

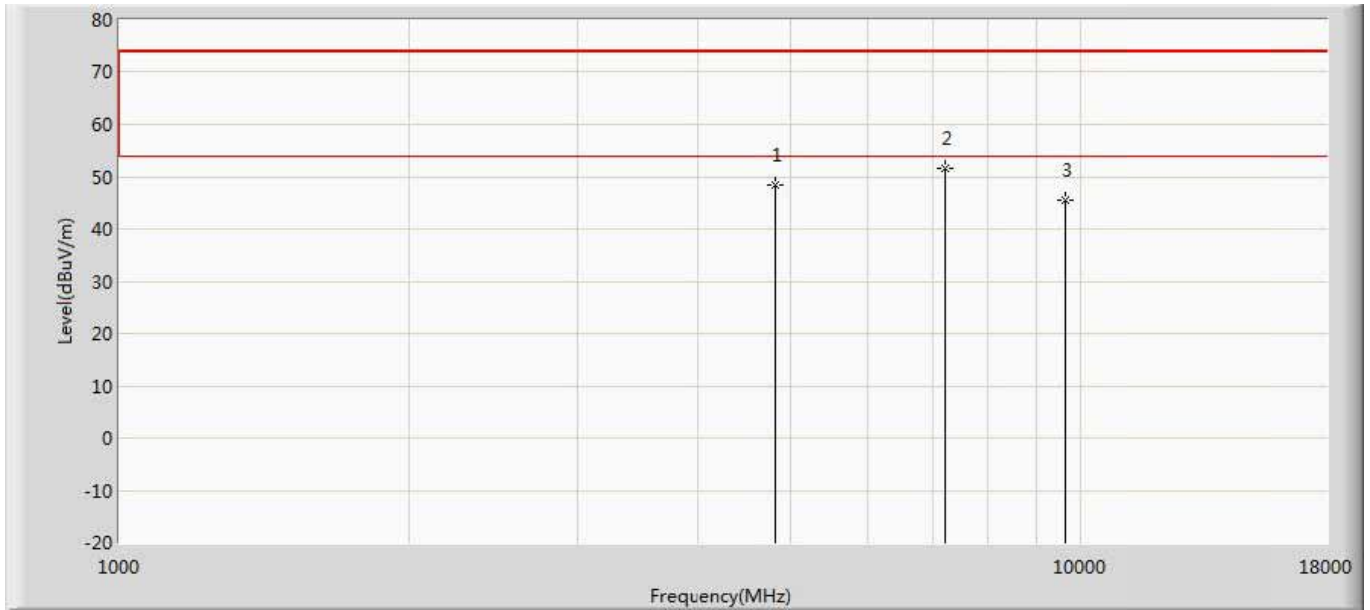

No	Mark	Frequency (MHz)	Measure Level (dBuV/m)	Reading Level (dBuV)	Over Limit (dB)	Limit (dBuV/m)	Factor (dB)	Type
1		4808.000	48.344	46.635	-25.656	74.000	1.709	PK
2	*	7213.500	51.682	46.409	-22.318	74.000	5.273	PK
3		9620.000	45.564	38.897	-28.436	74.000	6.667	PK

Engineer: YULIU	
Site: AC5	Time: 2019/04/15 - 10:13
Limit: FCC_Part15.209_RE(3m)	Margin: 0
Probe: Horn_3117_00167055(1-18GHz)	Polarity: Horizontal
EUT:LED LAMP	Power: AC 120V/60Hz
Note: Mode1:Transmit at 2405MHz by Zigbee	

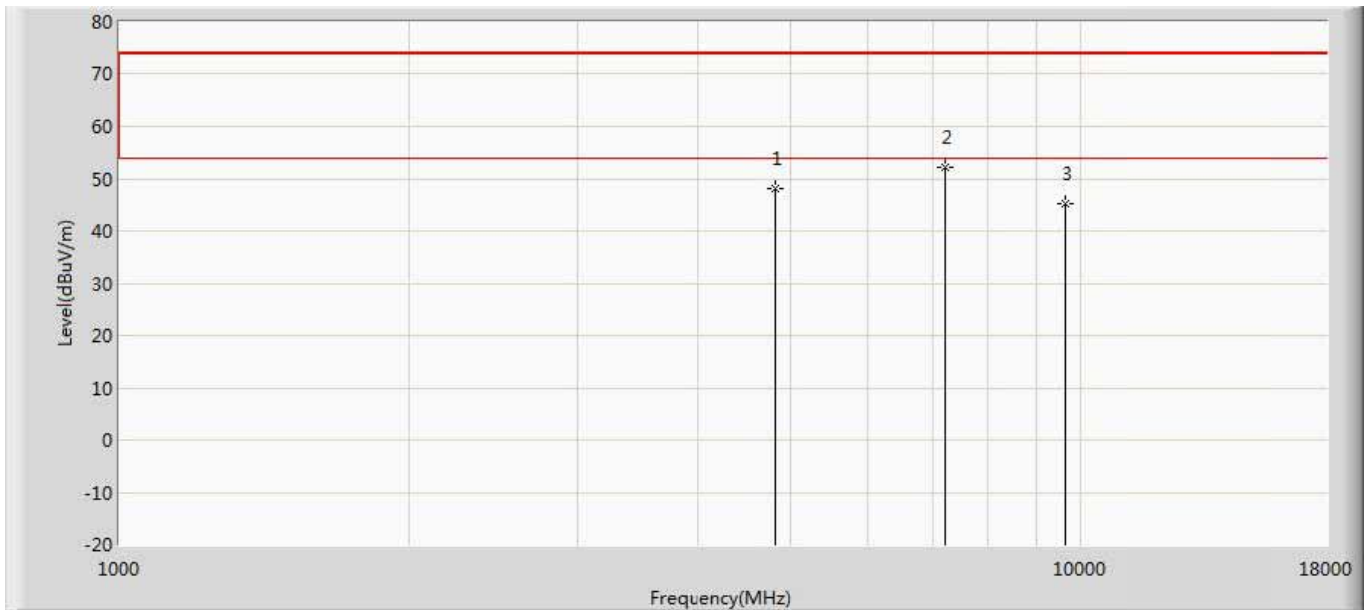

No	Mark	Frequency (MHz)	Measure Level (dBuV/m)	Reading Level (dBuV)	Over Limit (dB)	Limit (dBuV/m)	Factor (dB)	Type
1		4808.000	48.105	46.396	-25.895	74.000	1.709	PK
2	*	7213.500	52.074	46.801	-21.926	74.000	5.273	PK
3		9620.000	45.080	38.413	-28.920	74.000	6.667	PK

Engineer: YULIU	
Site: AC5	Time: 2019/04/15 - 10:13
Limit: FCC_Part15.209_RE(3m)	Margin: 0
Probe: Horn_3117_00167055(1-18GHz)	Polarity: Vertical
EUT:LED LAMP	Power: AC 120V/60Hz
Note: Mode1:Transmit at 2440MHz by Zigbee	

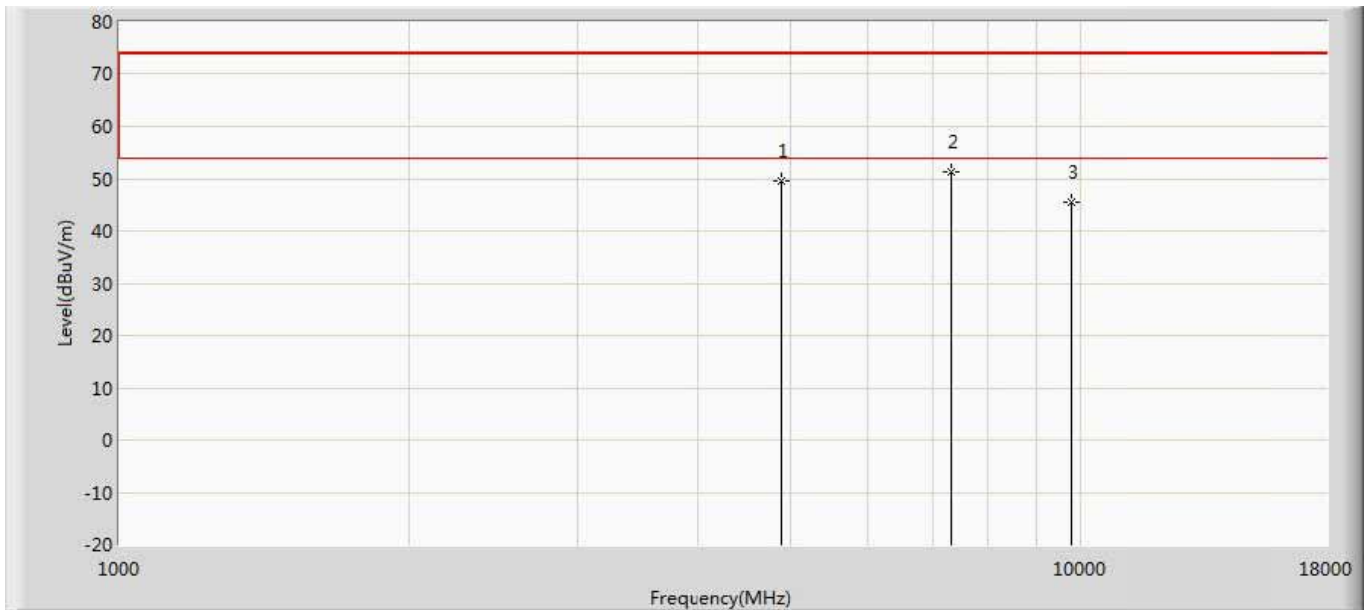

No	Mark	Frequency (MHz)	Measure Level (dBuV/m)	Reading Level (dBuV)	Over Limit (dB)	Limit (dBuV/m)	Factor (dB)	Type
1		4884.500	49.513	47.684	-24.487	74.000	1.829	PK
2	*	7324.000	51.374	45.779	-22.626	74.000	5.595	PK
3		9760.000	45.390	38.271	-28.610	74.000	7.120	PK

Engineer: YULIU	
Site: AC5	Time: 2019/04/15 - 10:13
Limit: FCC_Part15.209_RE(3m)	Margin: 0
Probe: Horn_3117_00167055(1-18GHz)	Polarity: Horizontal
EUT:LED LAMP	Power: AC 120V/60Hz
Note: Mode1:Transmit at 2440MHz by Zigbee	

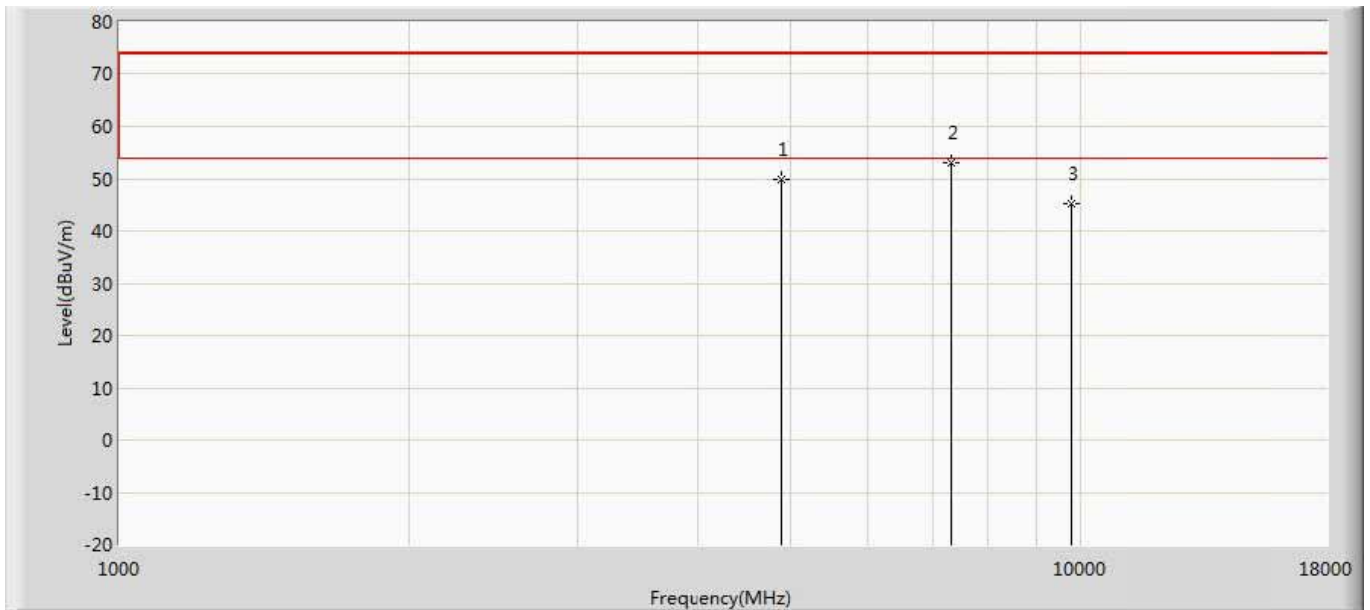

No	Mark	Frequency (MHz)	Measure Level (dBuV/m)	Reading Level (dBuV)	Over Limit (dB)	Limit (dBuV/m)	Factor (dB)	Type
1		4884.500	49.909	48.080	-24.091	74.000	1.829	PK
2	*	7324.000	52.977	47.382	-21.023	74.000	5.595	PK
3		9760.000	45.311	38.192	-28.689	74.000	7.120	PK

Engineer: YULIU	
Site: AC5	Time: 2019/04/15 - 10:13
Limit: FCC_Part15.209_RE(3m)	Margin: 0
Probe: Horn_3117_00167055(1-18GHz)	Polarity: Vertical
EUT:LED LAMP	Power: AC 120V/60Hz
Note: Mode1:Transmit at 2480MHz by Zigbee	

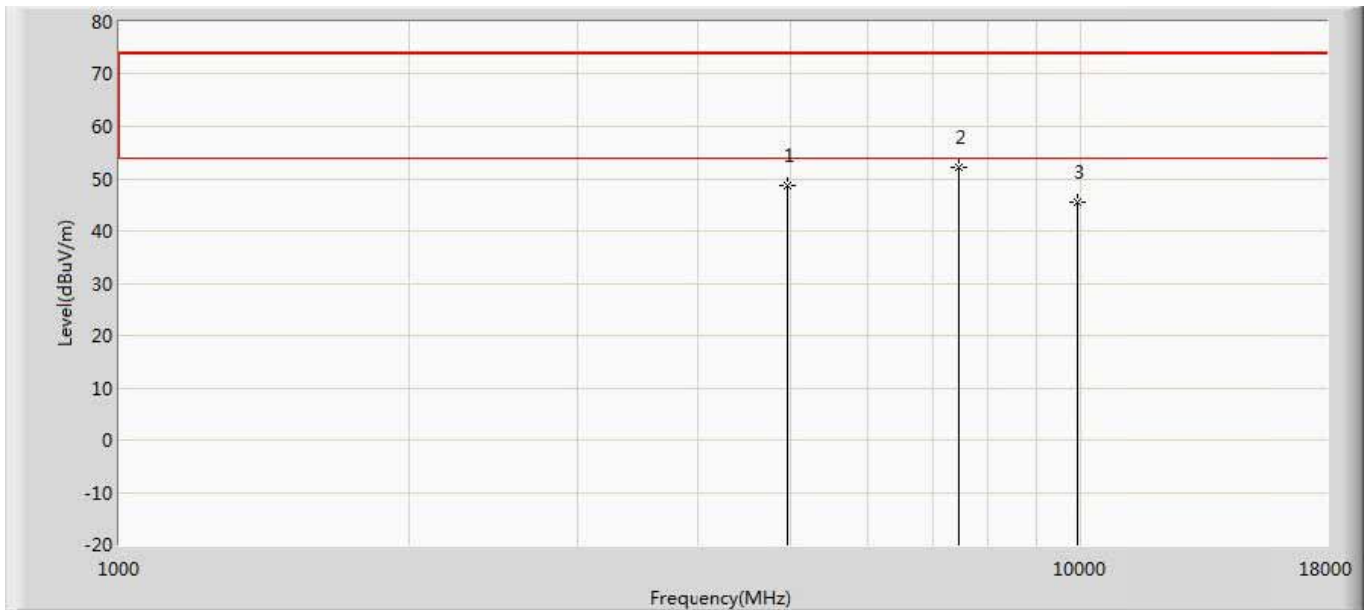

No	Mark	Frequency (MHz)	Measure Level (dBuV/m)	Reading Level (dBuV)	Over Limit (dB)	Limit (dBuV/m)	Factor (dB)	Type
1		4961.000	48.752	46.763	-25.248	74.000	1.989	PK
2	*	7443.000	52.310	46.980	-21.690	74.000	5.330	PK
3		9920.000	45.626	38.537	-28.374	74.000	7.088	PK

Engineer: YULIU	
Site: AC5	Time: 2019/04/15 - 10:13
Limit: FCC_Part15.209_RE(3m)	Margin: 0
Probe: Horn_3117_00167055(1-18GHz)	Polarity: Horizontal
EUT:LED LAMP	Power: AC 120V/60Hz
Note: Mode1:Transmit at 2480MHz by Zigbee	

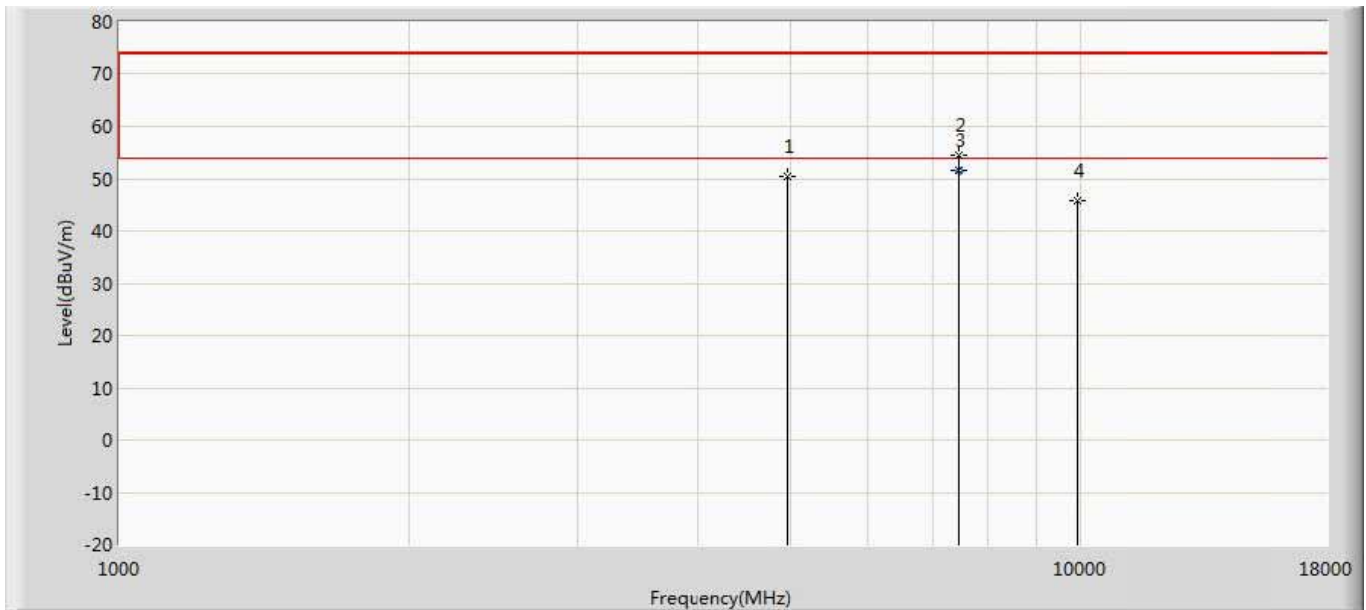

No	Mark	Frequency (MHz)	Measure Level (dBuV/m)	Reading Level (dBuV)	Over Limit (dB)	Limit (dBuV/m)	Factor (dB)	Type
1		4961.000	50.460	48.471	-23.540	74.000	1.989	PK
2		7443.000	54.568	49.238	-19.432	74.000	5.330	PK
3	*	7443.000	51.667	46.337	-2.333	54.000	5.330	AV
4		9920.000	45.926	38.837	-28.074	74.000	7.088	PK

Note: 1. Measure Level = Reading Level + Factor.

Note: 2. The test frequency range, 9kHz~30MHz, 18GHz~25GHz, both of the worst case are at least 20dB below the limits, therefore no data appear in the report.

Note: 3. This limit applies for using average detector, if the test result on peak is lower than average limit, then average measurement needn't be performed.

Note: 4. The RBW set up, see Clause 6.6.

The worst case of Radiated Emission below 1GHz:

Engineer: LiuYu	
Site: AC2	Time: 2019/04/03 - 15:23
Limit: FCC_Part15.109_RE(3m)_ClassB	Margin: 0
Probe: AC2_3M(30-1000M)	Polarity: Horizontal
EUT: LED LAMP	Power: AC 120V/60Hz
Note: Mode 1	

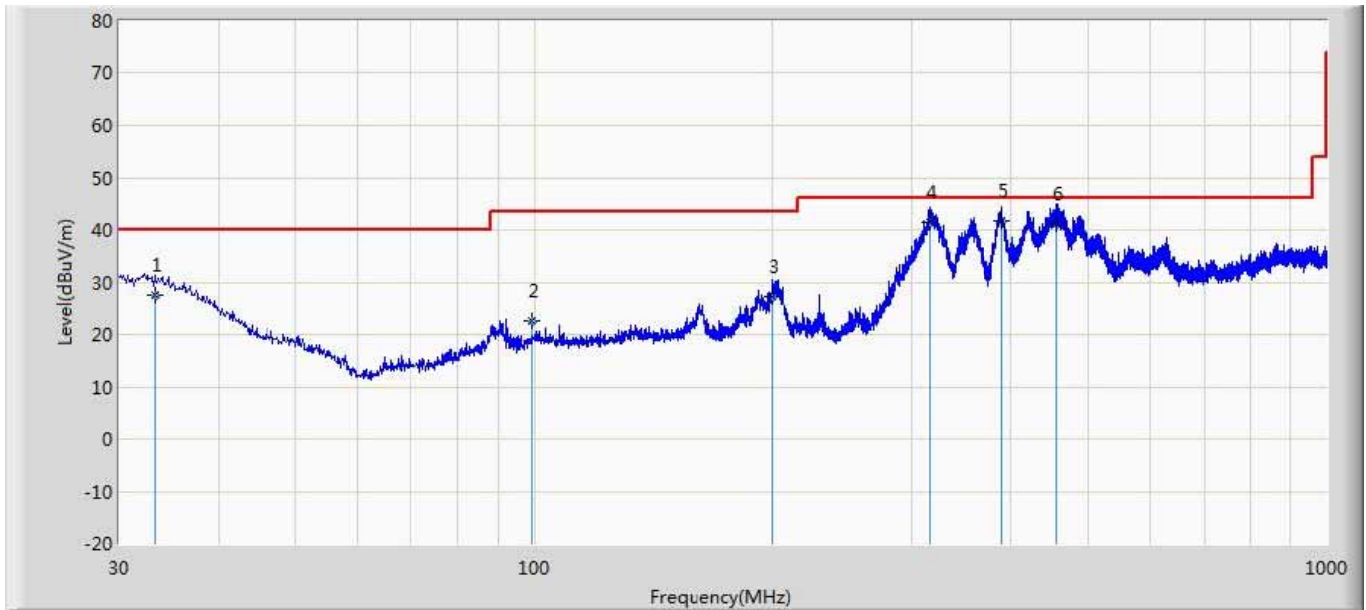

No	Mark	Frequency (MHz)	Measure Level (dBuV/m)	Reading Level (dBuV)	Over Limit (dB)	Limit (dBuV/m)	Factor (dB)	Ant Pos (cm)	Table Pos (deg)	Type
1		33.274	27.576	0.210	-12.424	40.000	27.366	135	42	QP
2		99.201	22.479	5.566	-21.021	43.500	16.913	144	136	QP
3		200.599	27.334	9.435	-16.166	43.500	17.899	133	147	QP
4		315.180	41.525	20.763	-4.475	46.000	20.762	194	236	QP
5	*	389.142	41.728	16.978	-4.272	46.000	24.750	197	12	QP
6		457.043	41.070	13.997	-4.930	46.000	27.073	156	139	QP

Note:

1. All Readings below 1GHz are Quasi-Peak, above are performed with peak and/or average measurements as necessary.
2. " * ", means this data is the worst emission level.
3. Measurement Level = Reading Level + Factor(Probe+Cable-Amp).

Engineer: LiuYu	
Site: AC2	Time: 2019/04/03 - 19:15
Limit: FCC_Part15.109_RE(3m)_ClassB	Margin: 0
Probe: AC2_3M(30-1000M)	Polarity: Vertical
EUT: LED LAMP	Power: AC 120V/60Hz
Note: Mode 1	

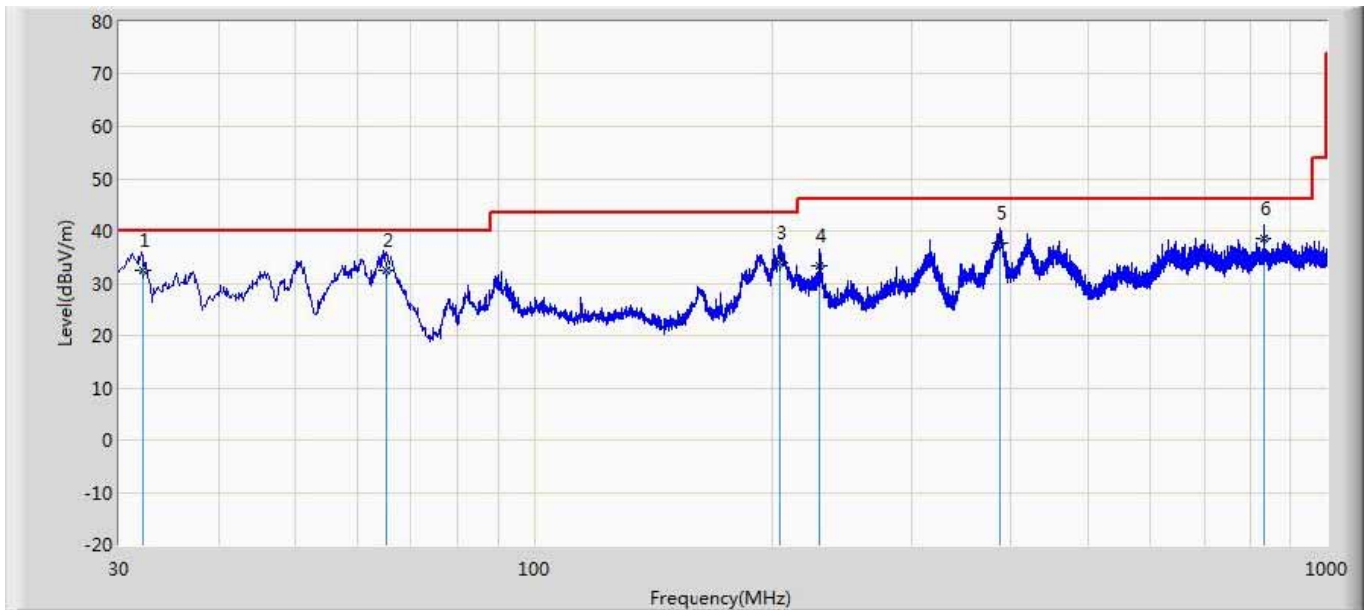

No	Mark	Frequency (MHz)	Measure Level (dBuV/m)	Reading Level (dBuV)	Over Limit (dB)	Limit (dBuV/m)	Factor (dB)	Ant Pos (cm)	Table Pos (deg)	Type
1	*	32.182	32.467	8.879	-7.533	40.000	23.588	156	338	QP
2		65.284	32.395	16.379	-7.605	40.000	16.016	194	136	QP
3		204.721	33.810	10.214	-9.690	43.500	23.596	188	135	QP
4		229.699	33.373	10.739	-12.627	46.000	22.635	184	164	QP
5		387.809	37.660	13.746	-8.340	46.000	23.914	143	199	QP
6		831.463	38.443	5.549	-7.557	46.000	32.895	184	139	QP

Note:

1. All Readings below 1GHz are Quasi-Peak, above are performed with peak and/or average measurements as necessary.
2. " * ", means this data is the worst emission level.
3. Measurement Level = Reading Level + Factor(Probe+Cable-Amp).

5. Emissions in non-restricted frequency bands

5.1. Test Equipment

Emissions in non-restricted frequency bands / TR-8					
Instrument	Manufacturer	Type No.	Serial No.	Cal. Date	Cal. Due Date
Spectrum Analyzer	Agilent	N9010A	MY48030494	2019.02.04	2020.02.03
EXA Spectrum Analyzer	Keysight	N9010A	MY55370495	2018.04.09	2019.04.08
MXA Signal Analyzer	Keysight	N9020A	MY56060147	2018.04.09	2019.04.08
Temperature/Humidity Meter	zhichen	ZC1-2	TR8-TH	2018.04.10	2019.04.09

Note: All equipments are calibrated with traceable calibrations. Each calibration is traceable to the national or international standards.

5.2. Test Setup

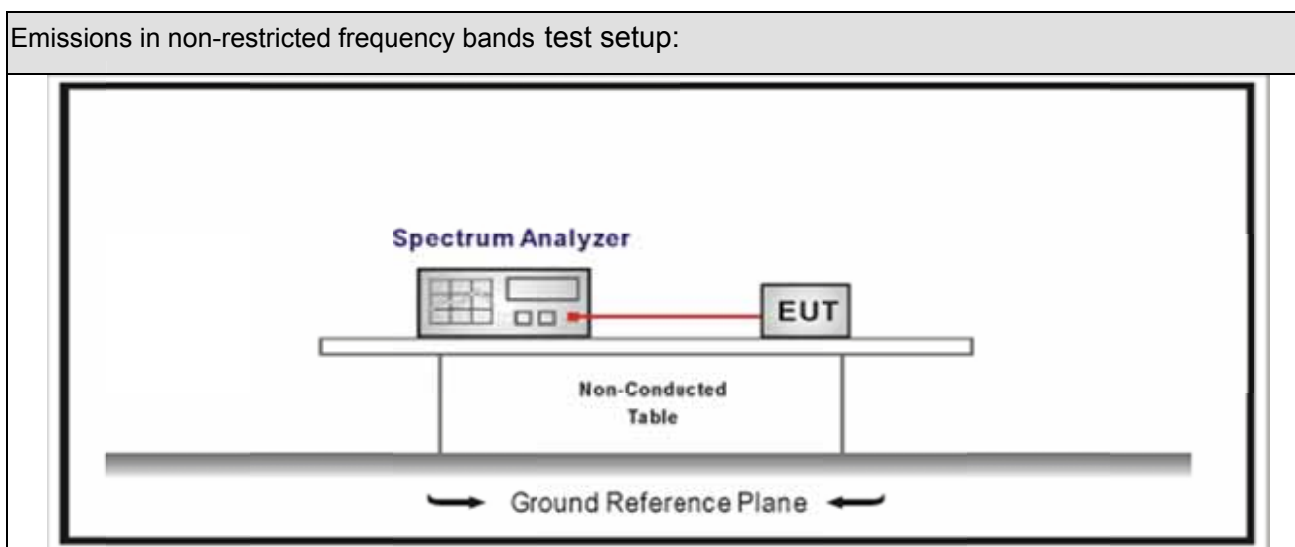



5.3. Limit

Un-Restricted Band Emissions Limit	
RF Output power (Detection methods)	Limit(dB)
RF Output power(Average detector)	30c(Note1)
RF Output power(PK detector)	20c(Note2)
<p>Note 1: If maximum conducted (average) output power was used to demonstrate compliance as described in 9.2, then the peak power in any 100 kHz bandwidth outside of the authorized frequency band shall be attenuated by at least 30 dB relative to the maximum in-band peak PSD level in 100 kHz (i.e., 30 dBc).</p> <p>Note 2: If the maximum peak conducted output power procedure was used, then the peak output power measured in any 100 kHz bandwidth outside of the authorized frequency band shall be attenuated by at least 20 dB relative to the maximum in-band peak PSD level in 100 kHz (i.e., 20 dBc).</p>	

5.4. Test Procedure

Test Method			
	References Rule	Chapter	Description
<input checked="" type="checkbox"/>	ANSI C63.10	11.11	Emissions in non-restricted frequency bands
	<input checked="" type="checkbox"/> ANSI C63.10	11.11.2	Reference level measurement
	<input checked="" type="checkbox"/> ANSI C63.10	11.11.3	Emission level measurement
<input type="checkbox"/>	ANSI C63.10	11.12	Emissions in restricted frequency bands
	<input type="checkbox"/> ANSI C63.10	11.12.1	Radiated emission measurements
	<input type="checkbox"/> ANSI C63.10	11.12.2.7	Radiated spurious emission test
<input type="checkbox"/>	ANSI C63.10	6.4	Radiated emissions from unlicensed wireless devices below 30 MHz
<input type="checkbox"/>	ANSI C63.10	6.5	Radiated emissions from unlicensed wireless devices in the frequency range of 30 MHz to 1000 MHz
<input type="checkbox"/>	ANSI C63.10	6.6	Radiated emissions from unlicensed wireless devices above 1 GHz
	<input type="checkbox"/> ANSI C63.10	11.12.2	Antenna-port conducted measurements
	<input type="checkbox"/> ANSI C63.10	11.12.2.3	Quasi-peak measurement procedure
	<input type="checkbox"/> ANSI C63.10	11.12.2.4	Peak power measurement procedure
	<input type="checkbox"/> ANSI C63.10	11.12.2.5	Average power measurement procedures
	<input type="checkbox"/> ANSI C63.10	11.12.2.5.1	Trace averaging with continuous EUT transmission at full power
	<input type="checkbox"/> ANSI C63.10	11.12.2.5.2	Trace averaging across ON and OFF times of the EUT transmissions followed by duty cycle correction
	<input type="checkbox"/> ANSI C63.10	11.12.2.5.3	Reduced VBW averaging across ON and OFF times of the EUT transmissions with max hold

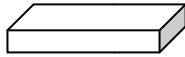
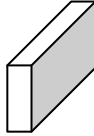
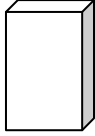
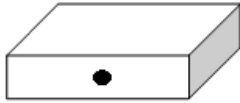
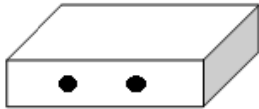
5.5. EUT test Axis definition

Item	Emissions in non-restricted frequency bands			
Device Category	<input type="checkbox"/>	Fixed point-to-point		
	<input type="checkbox"/>	Emit multiple directional beams, simultaneously or sequentially		
	<input checked="" type="checkbox"/>	Other cases		
Test mode	Mode 1			
Test method	<input type="checkbox"/>	Radiated		
		X Axis	Y Axis	Z Axis
				
		Worst Axis <input type="checkbox"/>	Worst Axis <input type="checkbox"/>	Worst Axis <input type="checkbox"/>
	<input checked="" type="checkbox"/>	Conducted		
	<input checked="" type="checkbox"/>	Chain 0		
				
	<input type="checkbox"/>	Chain 0	Chain 1	
				
		Worst Chain <input type="checkbox"/>	Worst Chain <input type="checkbox"/>	
	<input type="checkbox"/>	Chain 0	Chain 1	Chain 2
				
	Worst Chain <input type="checkbox"/>	Worst Chain <input type="checkbox"/>	Worst Chain <input type="checkbox"/>	

5.6. Test Result

Product Name	: LED lamp	Power	: AC 120V/60Hz
Test Mode	: Mode 1	Test Site	: TR-8
Test Date	: 2019.03.15		

Mode	Channel	Test Frequency (MHz)	In-Band PSD[a] (dBm/100kHz)	Frequency (MHz)	Out-Band PSD[b] (dBm/100kHz)	[a]-[b] (dB)	Limit (dB)	Result
1	11	2405	6.121	2400.00	-45.326	51.447	>20	Pass
1	26	2480	6.800	2500.00	-60.117	66.917	>20	Pass

Note: The worst case of Emissions in non-restricted frequency bands as below:

Mode 1 CH11 (2405MHz)



6. Radiated Emission Band Edge

6.1. Test Equipment

Radiated Emission Band Edge / AC-5					
Instrument	Manufacturer	Type No.	Serial No.	Cal. Date	Cal. Due Date
EMI Receiver	Agilent	N9038A	MY51210196	2018.07.16	2019.07.15
Pre-Amplifier	Miteq	NSP1800-25	1364185	2018.05.03	2019.05.02
DRG Horn Antenna	ETS-Lindgren	3117	00167055	2018.07.12	2019.07.11
Broad-Band Horn Antenna	Schwarzbeck	BBHA9170	294	2018.09.18	2019.09.17
Coaxial Cable	Huber+Suhner	SUCOFLEX 106	AC5-C1	2019.02.28	2020.02.27
Coaxial Cable	Huber+Suhner	SUCOFLEX 106	AC5-C2	2019.02.28	2020.02.27
Temperature/Humidity Meter	Zhichen	ZC1-2	AC5-TH	2019.01.05	2020.01.04

6.2. Test Setup

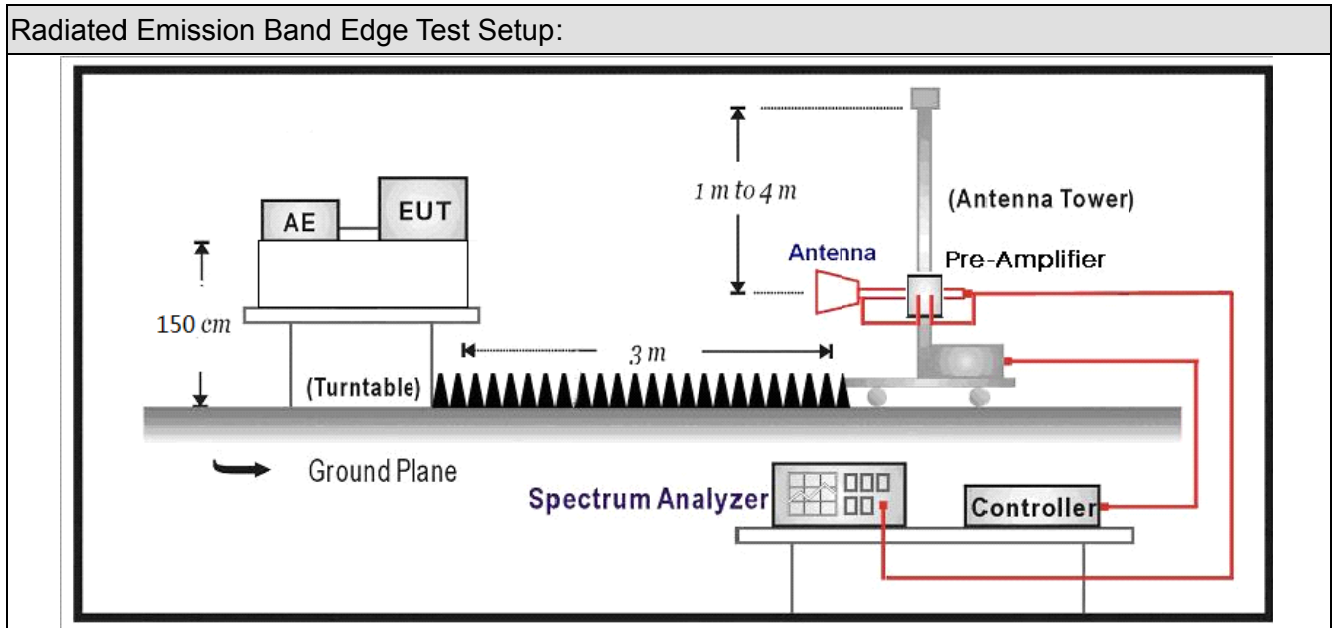

6.3. Limit



Band edge Limit				
Frequency bands (MHz)	Detector	Limit (dB μ V/m)	RBW (MHz)	Distance (m)
2310-2390	PK	74	1	3
2483.5-2500	AV	54	1	3

Note: The field strength of emissions appearing within these frequency bands shall not exceed the limits.

6.4. Test Procedure

Test Method			
	References Rule	Chapter	Description
<input checked="" type="checkbox"/>	ANSI C63.10	6.10	Band-edge testing
	<input checked="" type="checkbox"/> ANSI C63.10	6.10.5	Restricted-band band-edge measurements
	<input type="checkbox"/> ANSI C63.10	6.10.6	Marker-delta method
<input checked="" type="checkbox"/>	ANSI C63.10	11.12	Emissions in restricted frequency bands
	<input checked="" type="checkbox"/> ANSI C63.10	11.12.1	Radiated emission measurements
	<input checked="" type="checkbox"/> ANSI C63.10	11.12.2.7	Radiated spurious emission test
<input type="checkbox"/>	ANSI C63.10	6.4	Radiated emissions from unlicensed wireless devices below 30 MHz
<input type="checkbox"/>	ANSI C63.10	6.5	Radiated emissions from unlicensed wireless devices in the frequency range of 30 MHz to 1000 MHz
<input checked="" type="checkbox"/>	ANSI C63.10	6.6	Radiated emissions from unlicensed wireless devices above 1 GHz
	<input type="checkbox"/> ANSI C63.10	11.12.2.3	Quasi-peak measurement procedure
	<input type="checkbox"/> ANSI C63.10	11.12.2.4	Peak power measurement procedure
	<input type="checkbox"/> ANSI C63.10	11.12.2.5	Average power measurement procedures
	<input type="checkbox"/> ANSI C63.10	11.12.2.5.1	Trace averaging with continuous EUT transmission at full power
	<input type="checkbox"/> ANSI C63.10	11.12.2.5.2	Trace averaging across ON and OFF times of the EUT transmissions followed by duty cycle correction
	<input type="checkbox"/> ANSI C63.10	11.12.2.5.3	Reduced VBW averaging across ON and OFF times of the EUT transmissions with max hold

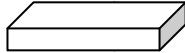
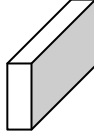
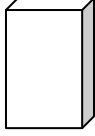
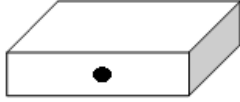
6.5. EUT test definition

Item	Radiated Emission Band Edge			
Device Category	<input type="checkbox"/>	Fixed point-to-point		
	<input type="checkbox"/>	Emit multiple directional beams, simultaneously or sequentially		
	<input checked="" type="checkbox"/>	Other cases		
Test mode	Mode 1			
Test method	<input checked="" type="checkbox"/>	Radiated		
		X Axis	Y Axis	Z Axis
				
		Worst Axis <input checked="" type="checkbox"/>	Worst Axis <input type="checkbox"/>	Worst Axis <input type="checkbox"/>
	<input type="checkbox"/>	Conducted		
	<input type="checkbox"/>	Chain 0		
				
	<input type="checkbox"/>	Chain 0	Chain 1	
				
	<input type="checkbox"/>	Chain 0	Chain 1	Chain 2
				

6.6. Duty Cycle

Test Mode	Tx On (ms)	Tx Off (ms)	Reduced VBW (Hz)	Tx On + Tx Off (ms)	Duty Cycle
Zigbee	N/A	N/A	10	N/A	100%

Mode1

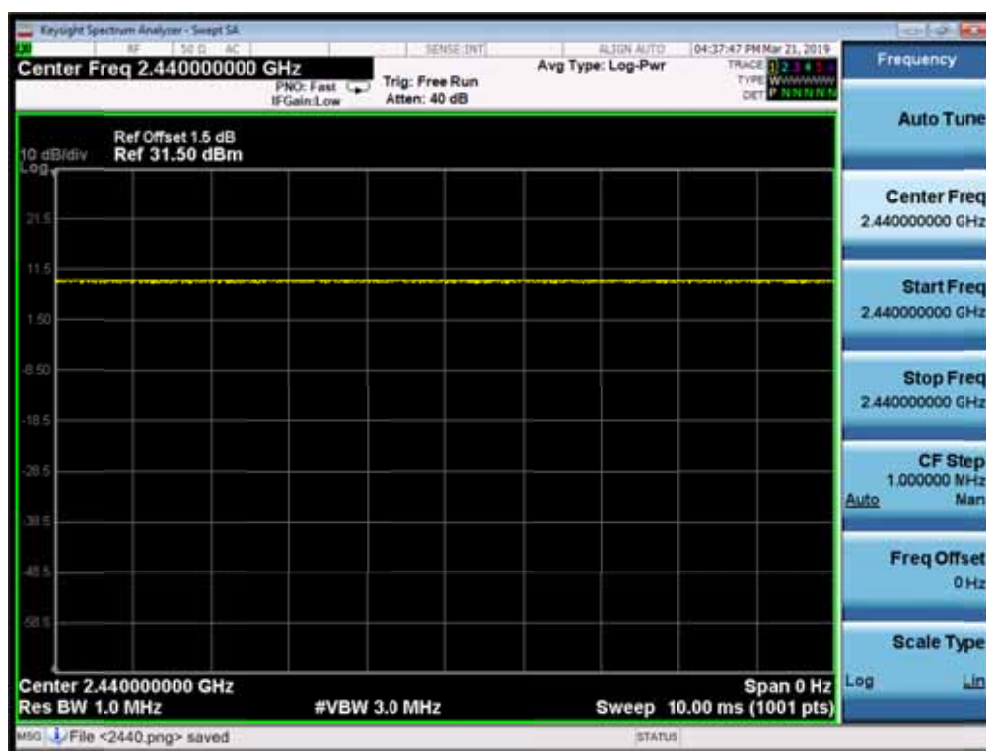

6.7 Test Result

Muruta:

Engineer: YULIU	
Site: AC5	Time: 2019/03/08 - 15:56
Limit: FCC_Part15.209_RE(3m)	Margin: 0
Probe: Horn_3117_00167055(1-18GHz)	Polarity: Vertical
EUT: LED LAMP	Power: AC 120V/60Hz
Note: Mode1:Transmit at 2405Mhz by Zigbee	

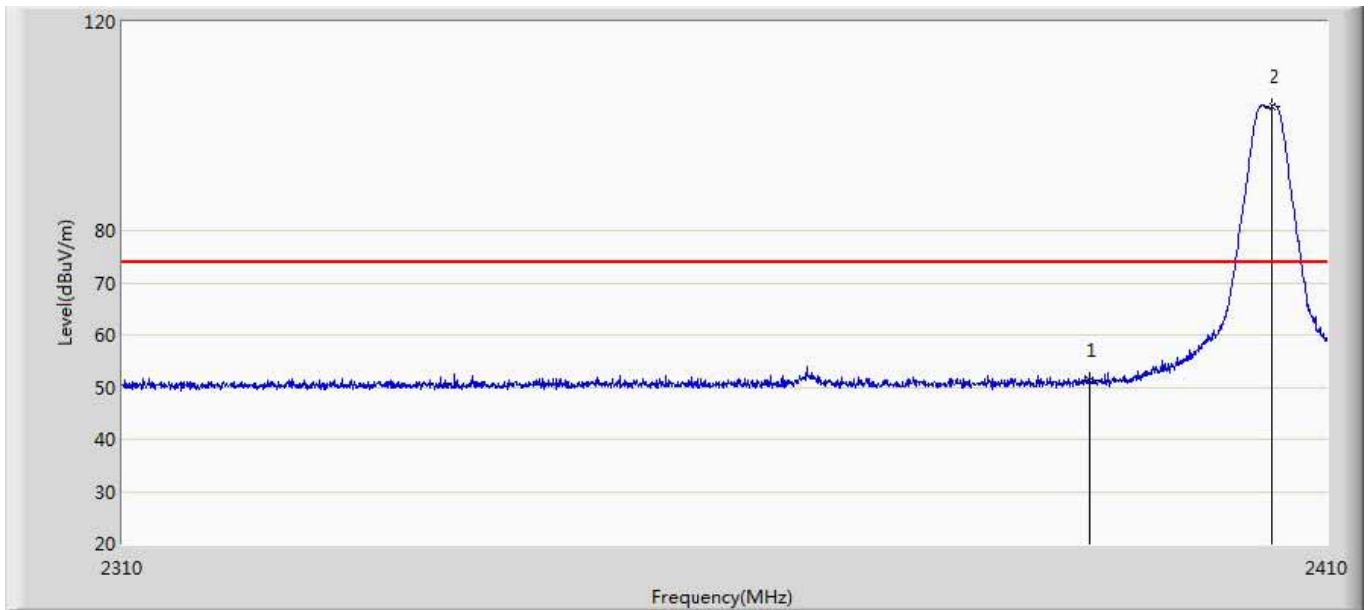

No	Mark	Frequency (MHz)	Measure Level (dBuV/m)	Reading Level (dBuV)	Over Limit (dB)	Limit (dBuV/m)	Factor (dB)	Type
1		2390.000	51.406	15.724	-22.594	74.000	35.682	PK
2	*	2405.400	103.846	68.124	29.846	74.000	35.722	PK

Engineer: YULIU	
Site: AC5	Time: 2019/03/25 - 22:04
Limit: FCC_Part15.209_RE(3m)	Margin: 0
Probe: Horn_3117_00167055(1-18GHz)	Polarity: Vertical
EUT: LED LAMP	Power: AC 120V/60Hz
Note: Mode1:Transmit at 2405Mhz by Zigbee	

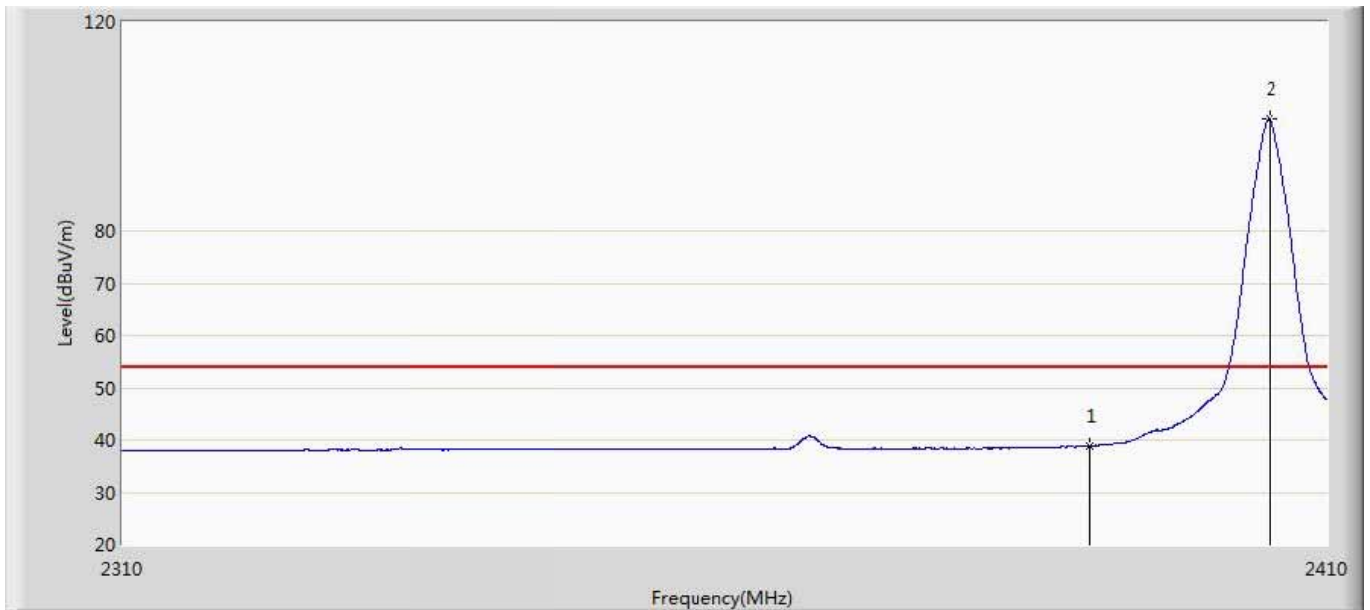

No	Mark	Frequency (MHz)	Measure Level (dBuV/m)	Reading Level (dBuV)	Over Limit (dB)	Limit (dBuV/m)	Factor (dB)	Type
1		2390.000	38.840	3.158	-15.160	54.000	35.682	AV
2	*	2405.150	101.404	65.683	47.404	54.000	35.721	AV

Engineer: YULIU	
Site: AC5	Time: 2019/03/25 - 22:05
Limit: FCC_Part15.209_RE(3m)	Margin: 0
Probe: Horn_3117_00167055(1-18GHz)	Polarity: Horizontal
EUT: LED LAMP	Power: AC 120V/60Hz
Note: Mode1:Transmit at 2405Mhz by Zigbee	

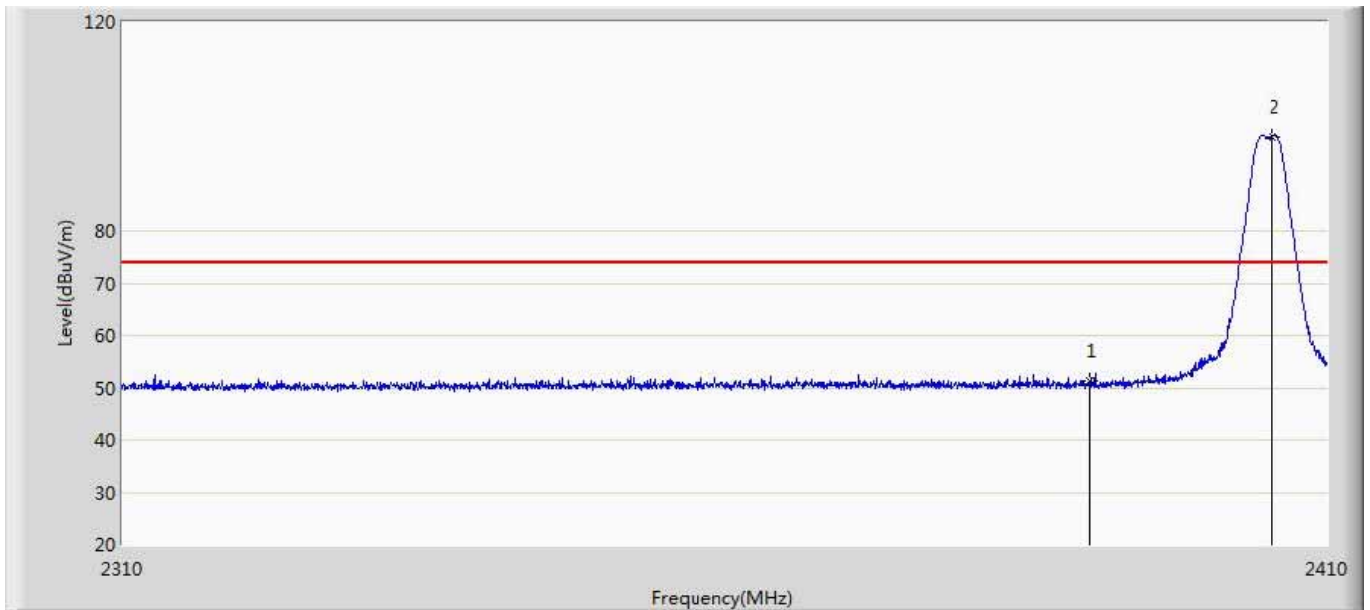

No	Mark	Frequency (MHz)	Measure Level (dBuV/m)	Reading Level (dBuV)	Over Limit (dB)	Limit (dBuV/m)	Factor (dB)	Type
1		2390.000	51.286	15.604	-22.714	74.000	35.682	PK
2	*	2405.350	98.109	62.387	24.109	74.000	35.721	PK

Engineer: YULIU	
Site: AC5	Time: 2019/03/25 - 22:08
Limit: FCC_Part15.209_RE(3m)	Margin: 0
Probe: Horn_3117_00167055(1-18GHz)	Polarity: Horizontal
EUT: LED LAMP	Power: AC 120V/60Hz
Note: Mode1:Transmit at 2405Mhz by Zigbee	

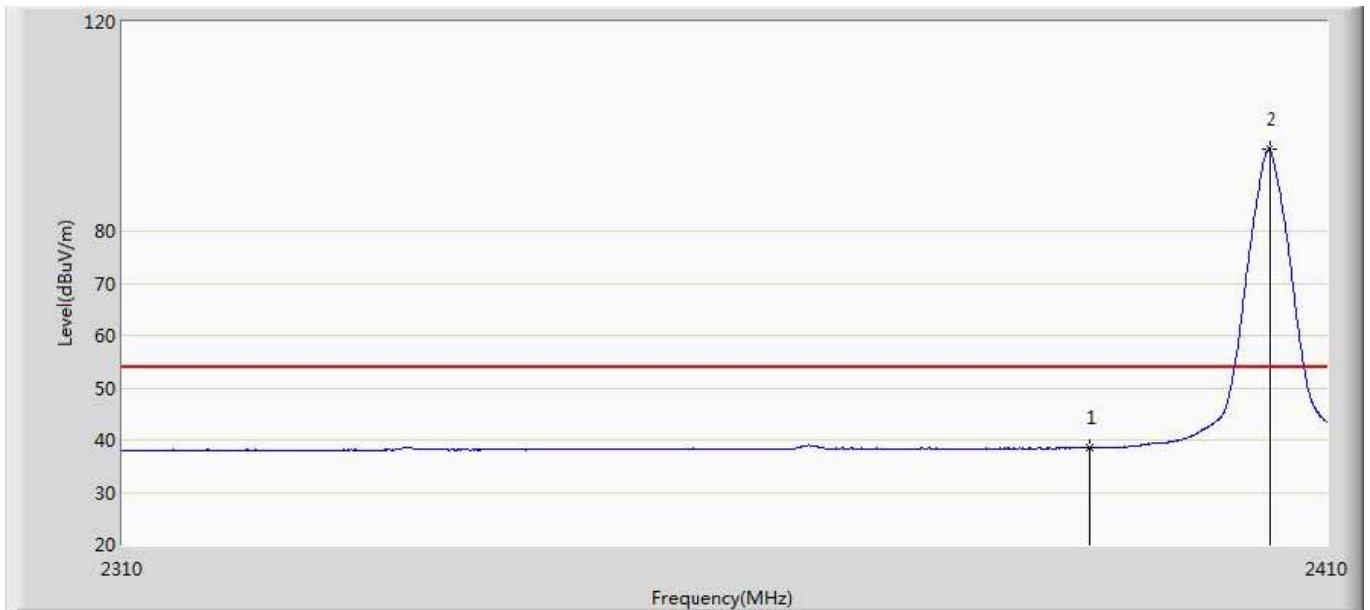

No	Mark	Frequency (MHz)	Measure Level (dBuV/m)	Reading Level (dBuV)	Over Limit (dB)	Limit (dBuV/m)	Factor (dB)	Type
1		2390.000	38.519	2.837	-15.481	54.000	35.682	AV
2	*	2405.150	95.767	60.046	41.767	54.000	35.721	AV

Engineer: YULIU	
Site: AC5	Time: 2019/03/25 - 22:10
Limit: FCC_Part15.209_RE(3m)	Margin: 0
Probe: Horn_3117_00167055(1-18GHz)	Polarity: Vertical
EUT: LED LAMP	Power: AC 120V/60Hz
Note: Mode1:Transmit at 2480Mhz by Zigbee	

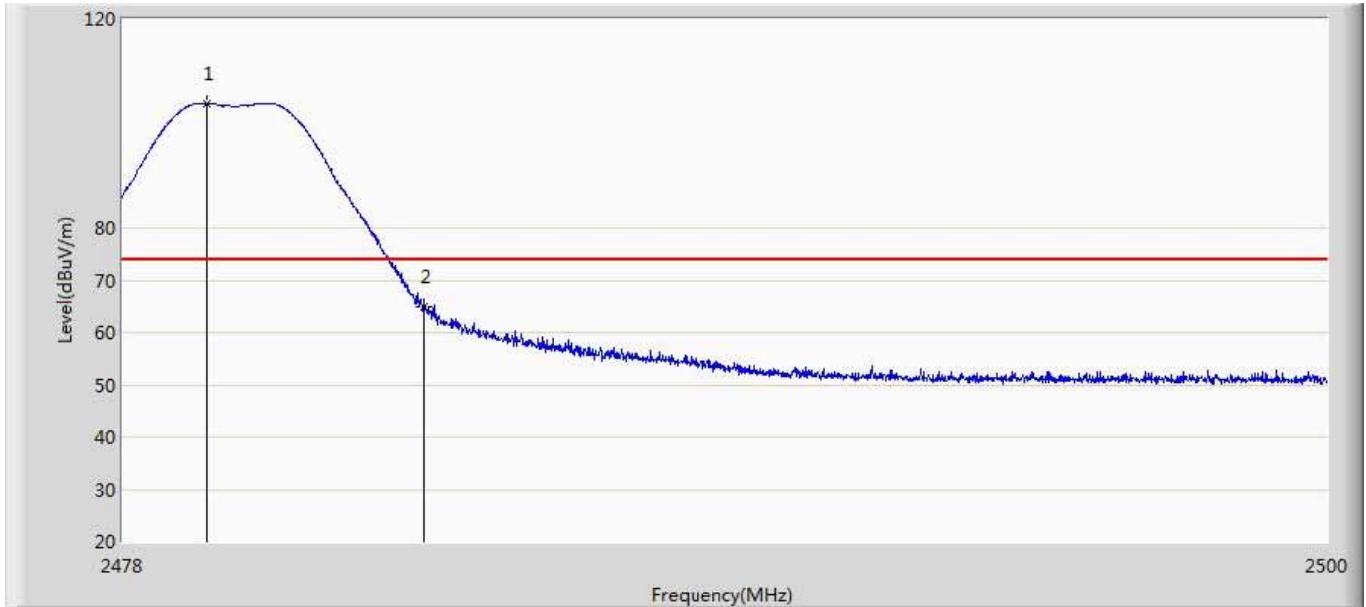

No	Mark	Frequency (MHz)	Measure Level (dBuV/m)	Reading Level (dBuV)	Over Limit (dB)	Limit (dBuV/m)	Factor (dB)	Type
1	*	2479.529	103.893	68.030	29.893	74.000	35.863	PK
2		2483.500	64.822	28.930	-9.178	74.000	35.891	PK

Engineer: YULIU	
Site: AC5	Time: 2019/03/25 - 22:13
Limit: FCC_Part15.209_RE(3m)	Margin: 0
Probe: Horn_3117_00167055(1-18GHz)	Polarity: Vertical
EUT: LED LAMP	Power: AC 120V/60Hz
Note: Mode1:Transmit at 2480Mhz by Zigbee	

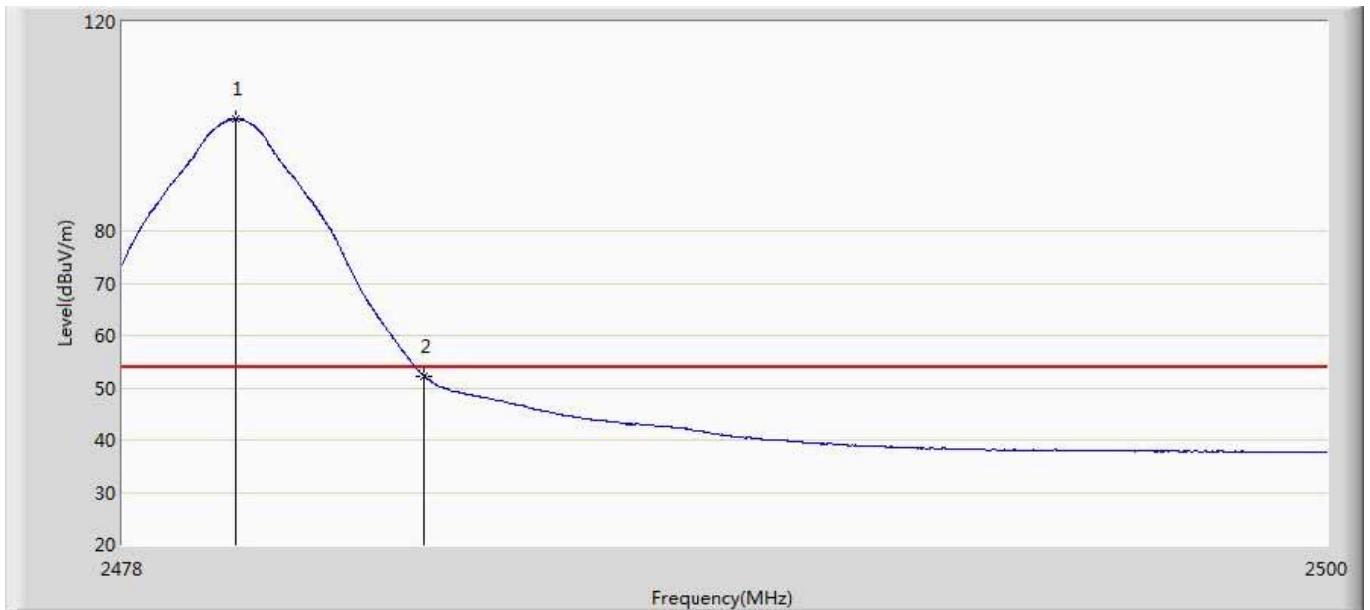

No	Mark	Frequency (MHz)	Measure Level (dBuV/m)	Reading Level (dBuV)	Over Limit (dB)	Limit (dBuV/m)	Factor (dB)	Type
1	*	2480.046	101.365	65.498	47.365	54.000	35.866	AV
2		2483.500	52.273	16.381	-1.727	54.000	35.891	AV

Engineer: YULIU	
Site: AC5	Time: 2019/03/25 - 22:14
Limit: FCC_Part15.209_RE(3m)	Margin: 0
Probe: Horn_3117_00167055(1-18GHz)	Polarity: Horizontal
EUT: LED LAMP	Power: AC 120V/60Hz
Note: Mode1:Transmit at 2480Mhz by Zigbee	

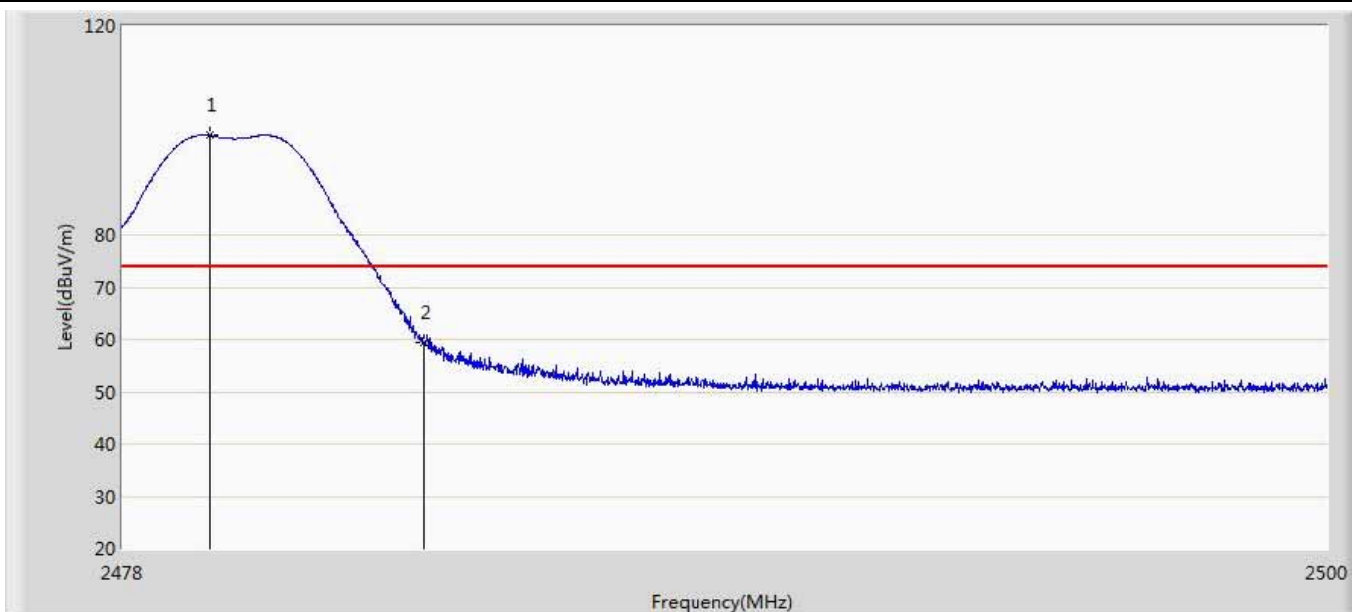

No	Mark	Frequency (MHz)	Measure Level (dBuV/m)	Reading Level (dBuV)	Over Limit (dB)	Limit (dBuV/m)	Factor (dB)	Type
1	*	2479.595	99.073	63.210	25.073	74.000	35.864	PK
2		2483.500	59.535	23.643	-14.465	74.000	35.891	PK

Engineer: YULIU	
Site: AC5	Time: 2019/03/25 - 22:16
Limit: FCC_Part15.209_RE(3m)	Margin: 0
Probe: Horn_3117_00167055(1-18GHz)	Polarity: Horizontal
EUT: LED LAMP	Power: AC 120V/60Hz
Note: Mode1:Transmit at 2480Mhz by Zigbee	

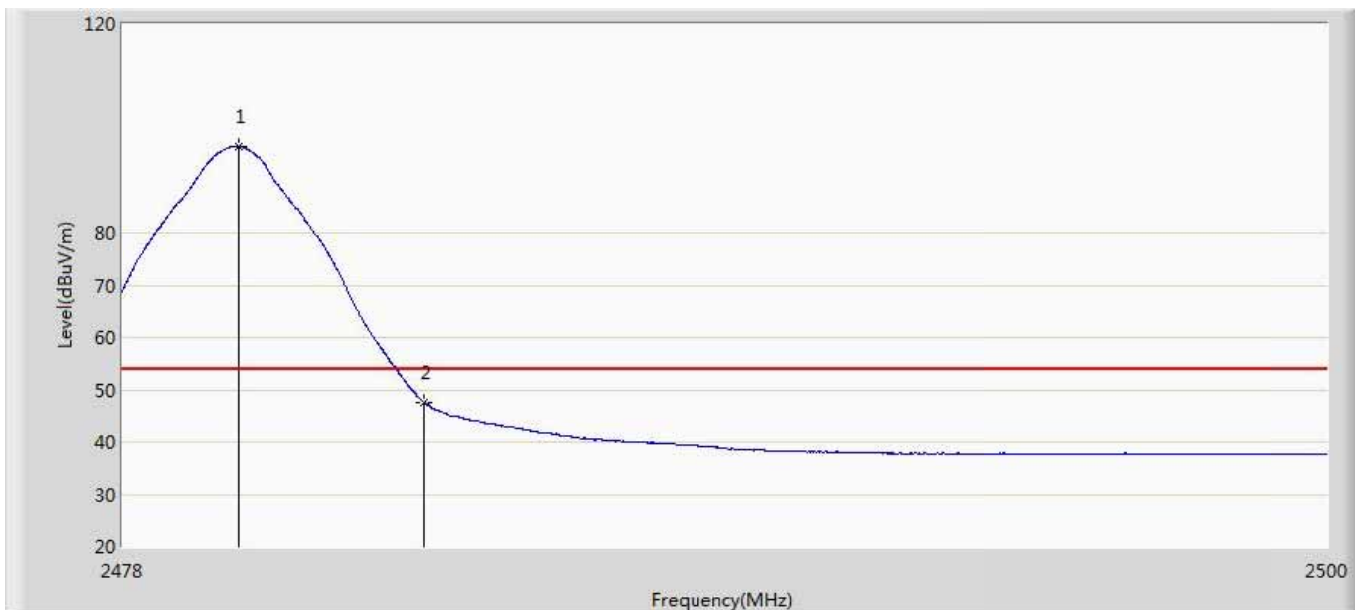

No	Mark	Frequency (MHz)	Measure Level (dBuV/m)	Reading Level (dBuV)	Over Limit (dB)	Limit (dBuV/m)	Factor (dB)	Type
1	*	2480.112	96.530	60.663	42.530	54.000	35.867	AV
2		2483.500	47.601	11.709	-6.399	54.000	35.891	AV

Diodes:

Engineer: YULIU	
Site: AC5	Time: 2019/03/08 - 15:56
Limit: FCC_Part15.209_RE(3m)	Margin: 0
Probe: Horn_3117_00167055(1-18GHz)	Polarity: Vertical
EUT: LED LAMP	Power: AC 120V/60Hz
Note: Mode1:Transmit at 2405Mhz by Zigbee	

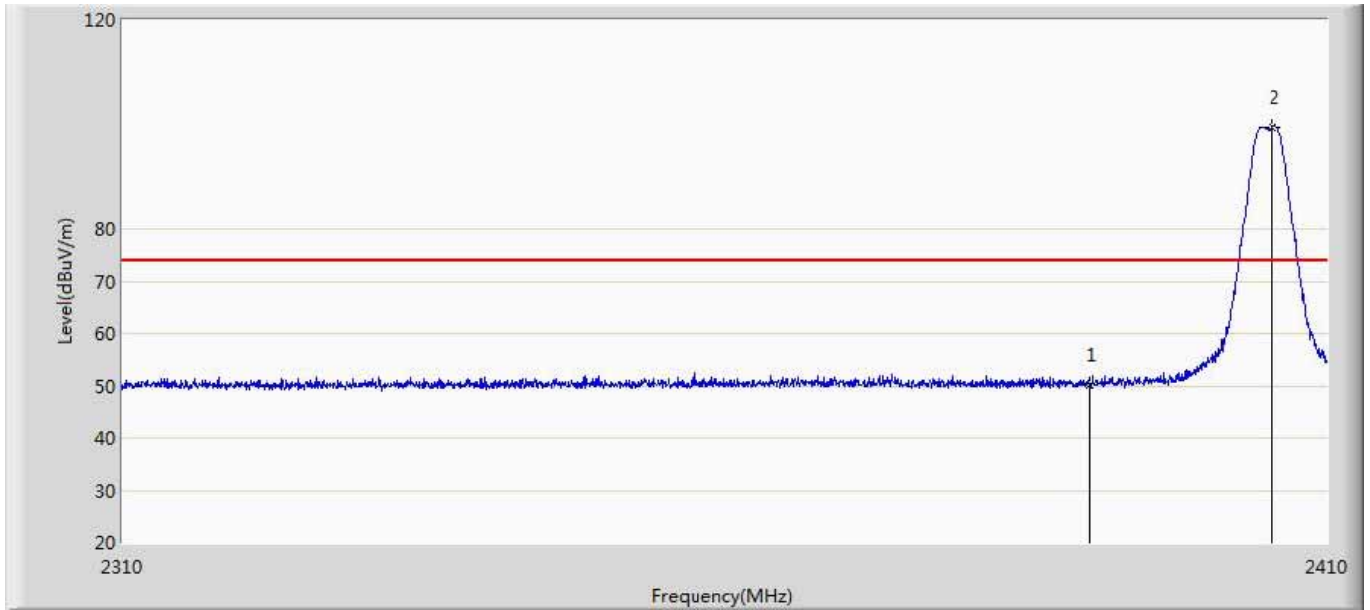

No	Mark	Frequency (MHz)	Measure Level (dBuV/m)	Reading Level (dBuV)	Over Limit (dB)	Limit (dBuV/m)	Factor (dB)	Type
1		2390.000	50.039	14.357	-23.961	74.000	35.682	PK
2	*	2405.350	99.357	63.635	25.357	74.000	35.721	PK

Engineer: YULIU	
Site: AC5	Time: 2019/04/01 - 22:08
Limit: FCC_Part15.209_RE(3m)	Margin: 0
Probe: Horn_3117_00167055(1-18GHz)	Polarity: Vertical
EUT: LED LAMP	Power: AC 120V/60Hz
Note: Mode1:Transmit at 2405Mhz by Zigbee	

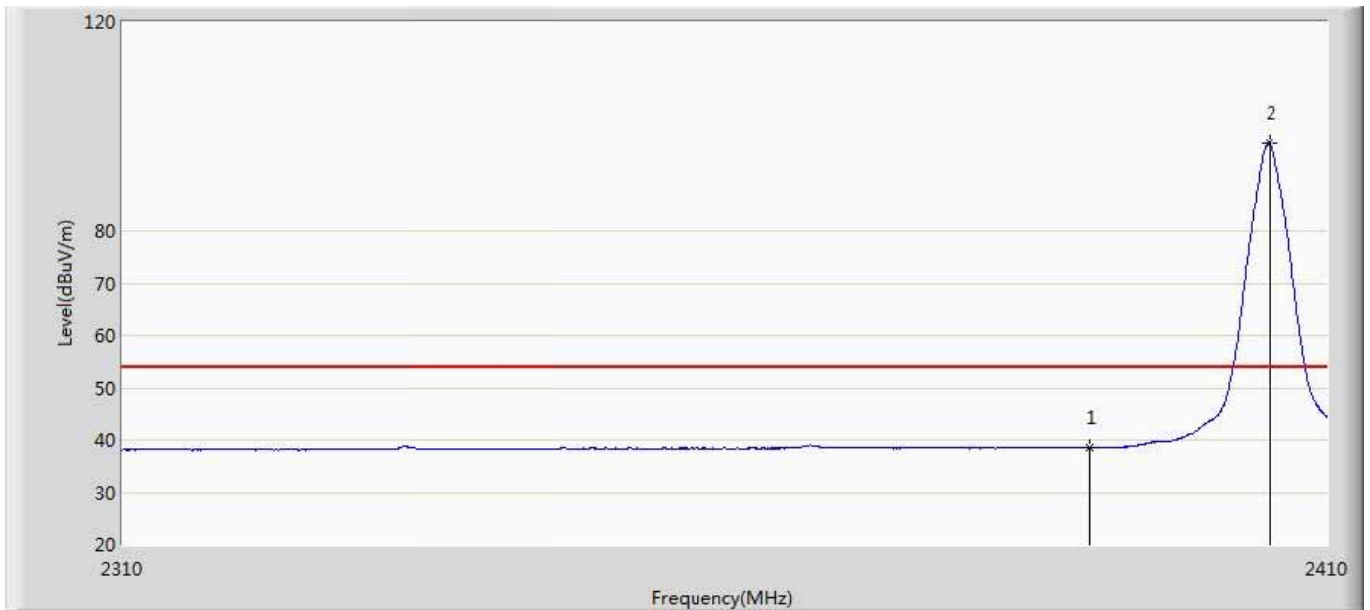

No	Mark	Frequency (MHz)	Measure Level (dBuV/m)	Reading Level (dBuV)	Over Limit (dB)	Limit (dBuV/m)	Factor (dB)	Type
1		2390.000	38.536	2.854	-15.464	54.000	35.682	AV
2	*	2405.150	96.943	61.222	42.943	54.000	35.721	AV

Engineer: YULIU	
Site: AC5	Time: 2019/04/01 - 22:10
Limit: FCC_Part15.209_RE(3m)	Margin: 0
Probe: Horn_3117_00167055(1-18GHz)	Polarity: Horizontal
EUT: LED LAMP	Power: AC 120V/60Hz
Note: Mode1:Transmit at 2405Mhz by Zigbee	

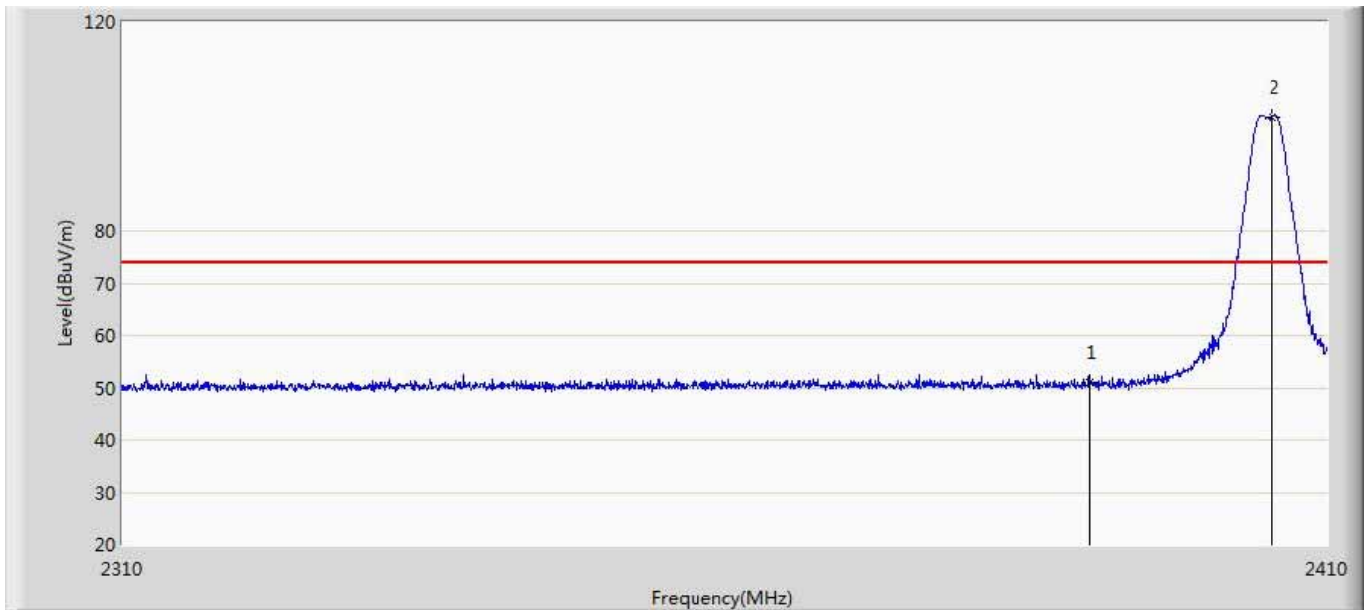

No	Mark	Frequency (MHz)	Measure Level (dBuV/m)	Reading Level (dBuV)	Over Limit (dB)	Limit (dBuV/m)	Factor (dB)	Type
1		2390.000	50.986	15.304	-23.014	74.000	35.682	PK
2	*	2405.350	101.870	66.148	27.870	74.000	35.721	PK

Engineer: YULIU	
Site: AC5	Time: 2019/04/01 - 22:12
Limit: FCC_Part15.209_RE(3m)	Margin: 0
Probe: Horn_3117_00167055(1-18GHz)	Polarity: Horizontal
EUT: LED LAMP	Power: AC 120V/60Hz
Note: Mode1:Transmit at 2405Mhz by Zigbee	

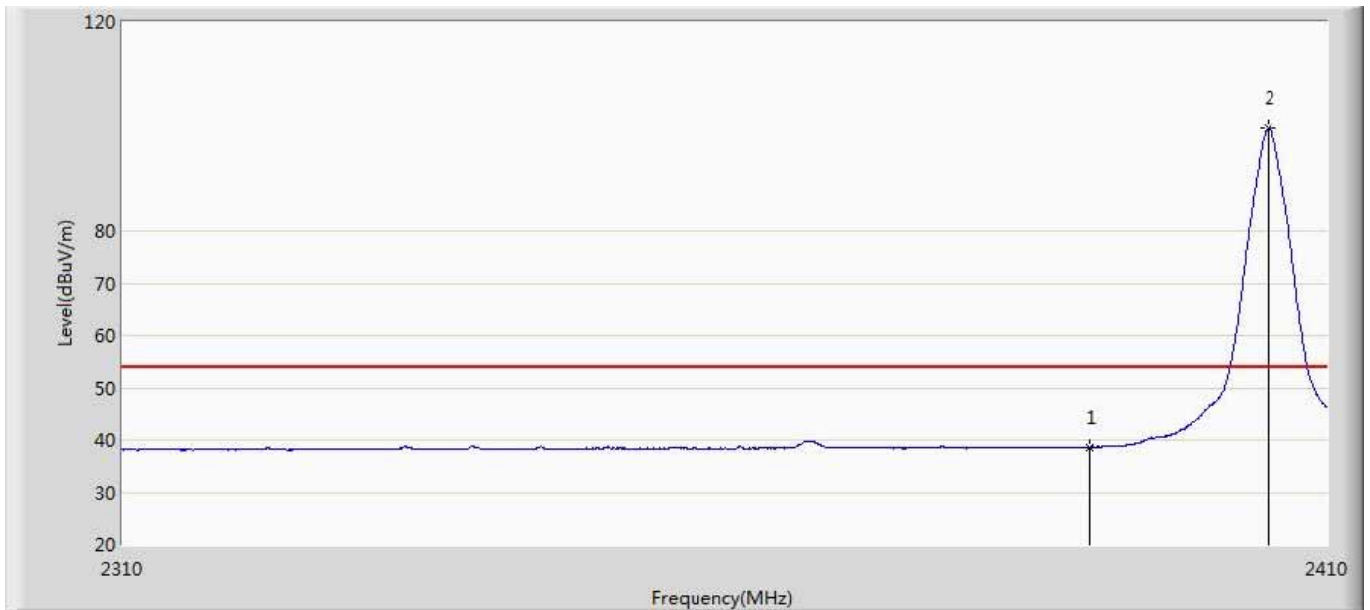

No	Mark	Frequency (MHz)	Measure Level (dBuV/m)	Reading Level (dBuV)	Over Limit (dB)	Limit (dBuV/m)	Factor (dB)	Type
1		2390.000	38.654	2.972	-15.346	54.000	35.682	AV
2	*	2405.000	99.677	63.956	45.677	54.000	35.721	AV

Engineer: YULIU	
Site: AC5	Time: 2019/04/01 - 22:14
Limit: FCC_Part15.209_RE(3m)	Margin: 0
Probe: Horn_3117_00167055(1-18GHz)	Polarity: Vertical
EUT: LED LAMP	Power: AC 120V/60Hz
Note: Mode1:Transmit at 2480Mhz by Zigbee	

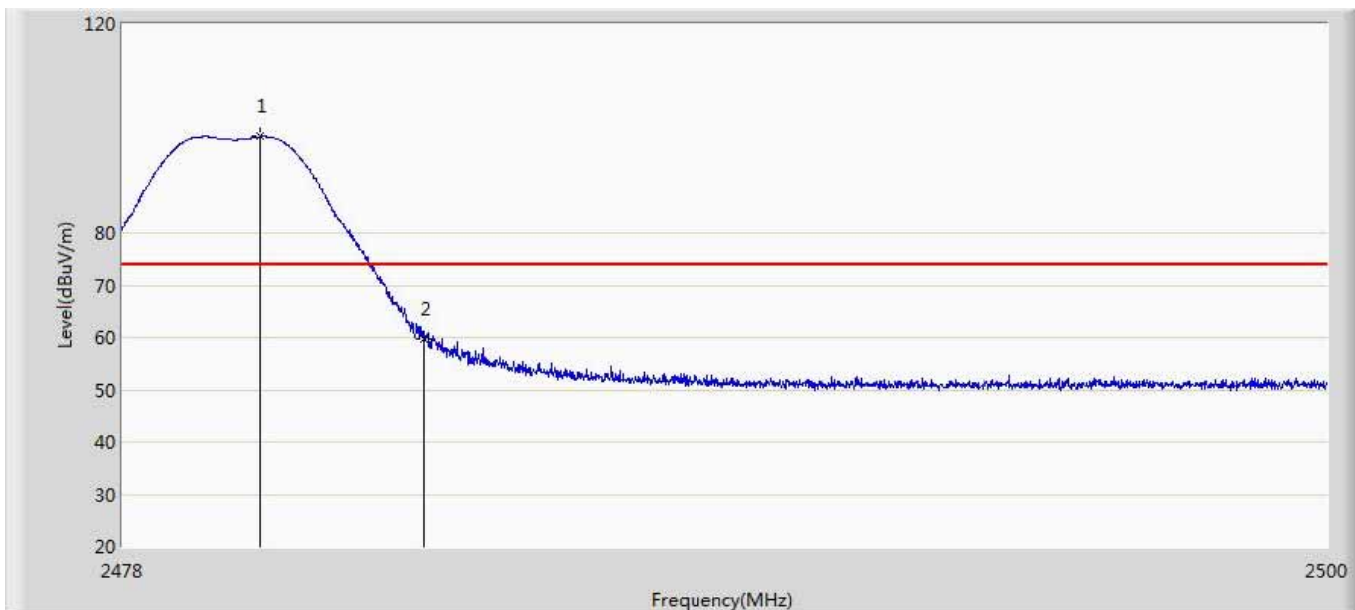

No	Mark	Frequency (MHz)	Measure Level (dBuV/m)	Reading Level (dBuV)	Over Limit (dB)	Limit (dBuV/m)	Factor (dB)	Type
1	*	2480.508	98.421	62.551	24.421	74.000	35.870	PK
2		2483.500	59.701	23.809	-14.299	74.000	35.891	PK

Engineer: YULIU	
Site: AC5	Time: 2019/04/01 - 22:17
Limit: FCC_Part15.209_RE(3m)	Margin: 0
Probe: Horn_3117_00167055(1-18GHz)	Polarity: Vertical
EUT: LED LAMP	Power: AC 120V/60Hz
Note: Mode1:Transmit at 2480Mhz by Zigbee	

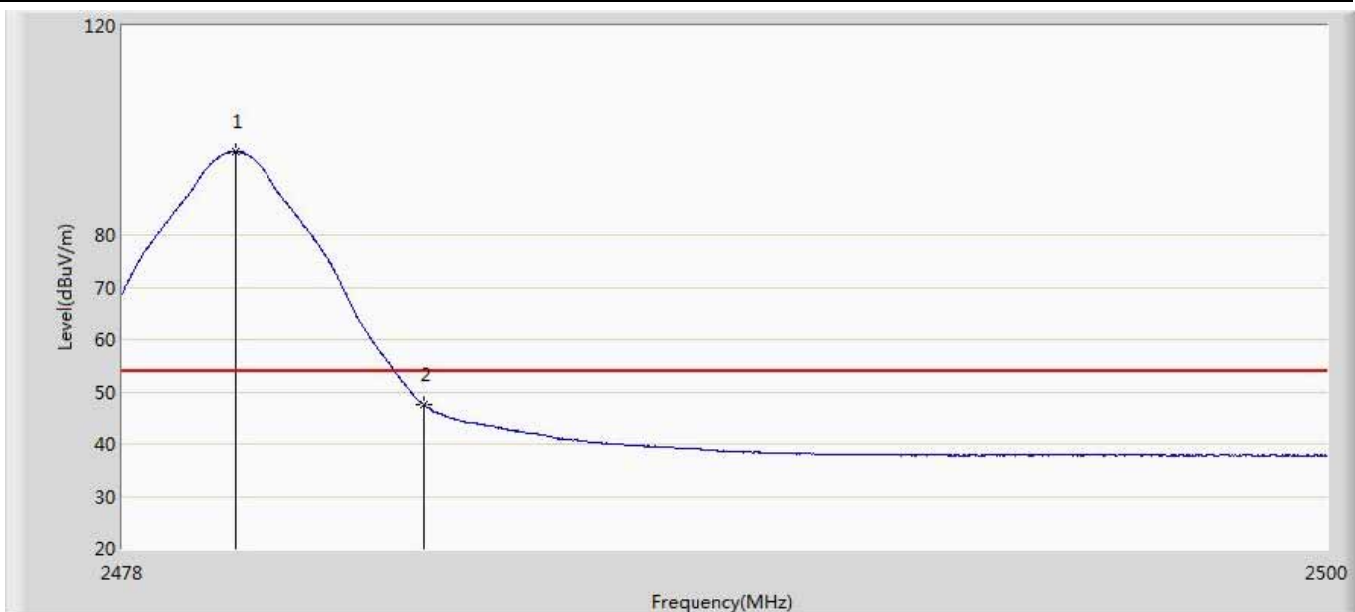

No	Mark	Frequency (MHz)	Measure Level (dBuV/m)	Reading Level (dBuV)	Over Limit (dB)	Limit (dBuV/m)	Factor (dB)	Type
1	*	2480.046	95.902	60.035	41.902	54.000	35.866	AV
2		2483.500	47.580	11.688	-6.420	54.000	35.891	AV

Engineer: YULIU	
Site: AC5	Time: 2019/04/01 - 22:19
Limit: FCC_Part15.209_RE(3m)	Margin: 0
Probe: Horn_3117_00167055(1-18GHz)	Polarity: Horizontal
EUT: LED LAMP	Power: AC 120V/60Hz
Note: Mode1:Transmit at 2480Mhz by Zigbee	

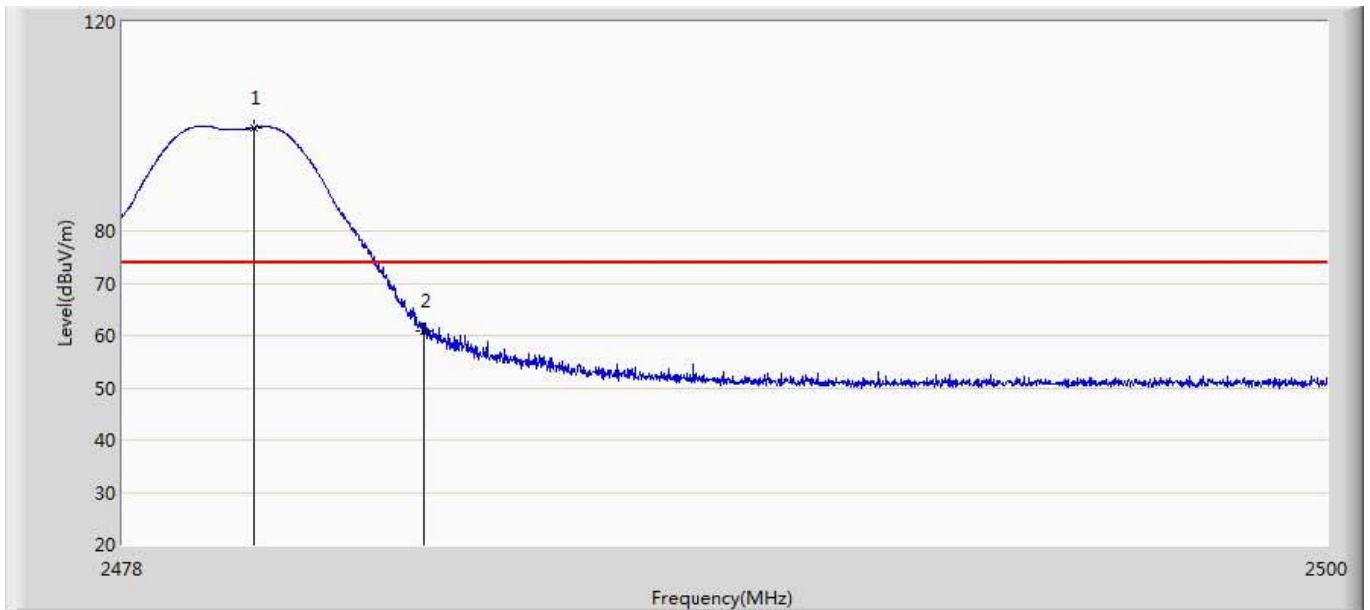

No	Mark	Frequency (MHz)	Measure Level (dBuV/m)	Reading Level (dBuV)	Over Limit (dB)	Limit (dBuV/m)	Factor (dB)	Type
1	*	2480.387	99.788	63.919	25.788	74.000	35.870	PK
2		2483.500	60.727	24.835	-13.273	74.000	35.891	PK

Engineer: YULIU	
Site: AC5	Time: 2019/04/01 - 22:21
Limit: FCC_Part15.209_RE(3m)	Margin: 0
Probe: Horn_3117_00167055(1-18GHz)	Polarity: Horizontal
EUT: LED LAMP	Power: AC 120V/60Hz
Note: Mode1:Transmit at 2480Mhz by Zigbee	

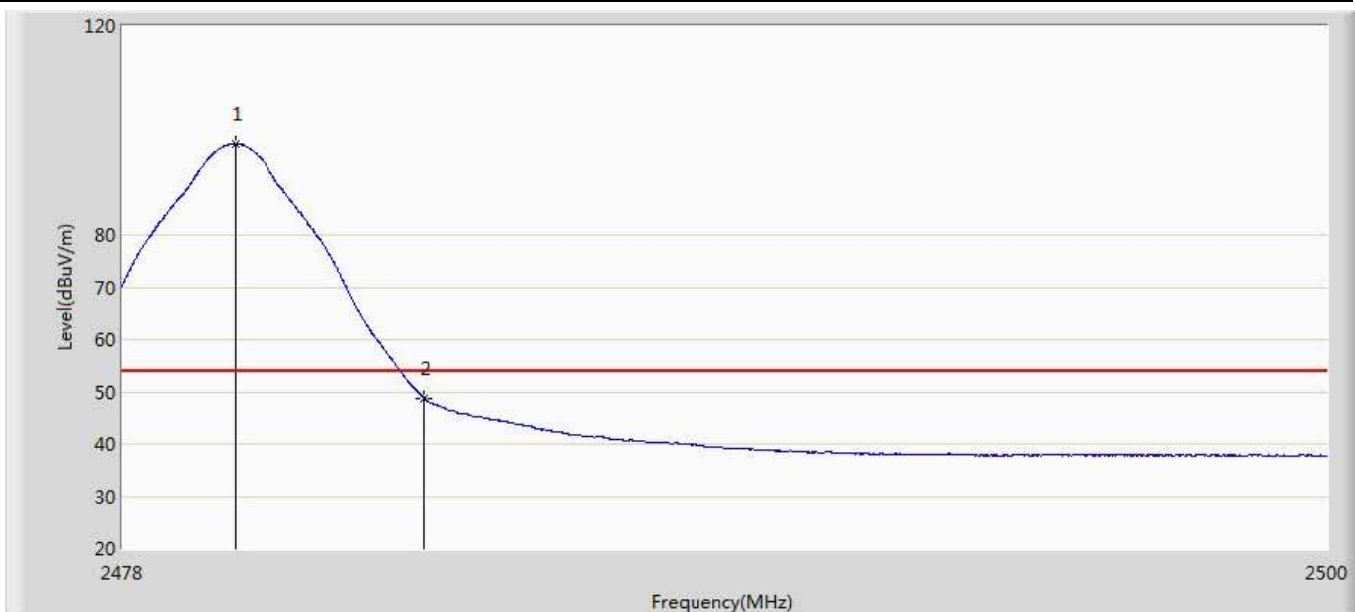

No	Mark	Frequency (MHz)	Measure Level (dBuV/m)	Reading Level (dBuV)	Over Limit (dB)	Limit (dBuV/m)	Factor (dB)	Type
1	*	2480.046	97.406	61.539	43.406	54.000	35.866	AV
2		2483.500	48.835	12.943	-5.165	54.000	35.891	AV

Kdx:

Engineer: YULIU	
Site: AC5	Time: 2019/03/08 - 15:56
Limit: FCC_Part15.209_RE(3m)	Margin: 0
Probe: Horn_3117_00167055(1-18GHz)	Polarity: Vertical
EUT:LED LAMP	Power: AC 120V/60Hz
Note: Mode1:Transmit at 2405MHz by Zigbee	

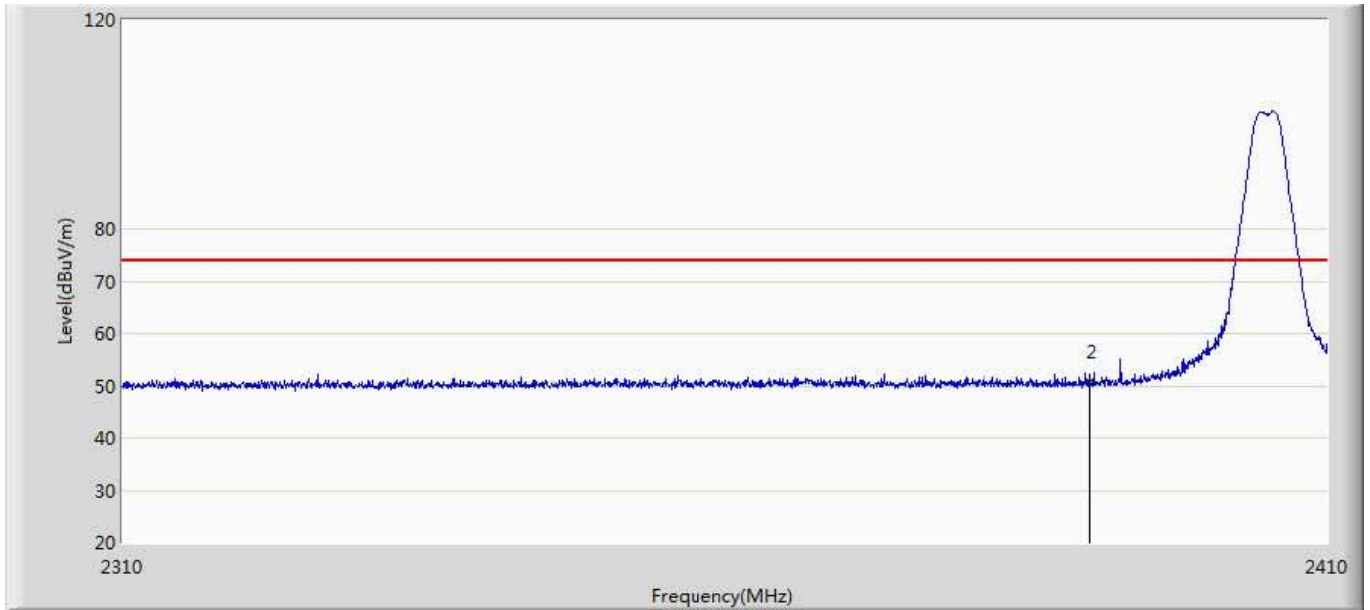

No	Mark	Frequency (MHz)	Measure Level (dBuV/m)	Reading Level (dBuV)	Over Limit (dB)	Limit (dBuV/m)	Factor (dB)	Type
1		1.000	1.000	-29.960	-66.621	67.621	30.960	PK
2	*	2390.000	50.869	15.187	-23.131	74.000	35.682	PK

Engineer: YULIU	
Site: AC5	Time: 2019/04/13 - 10:28
Limit: FCC_Part15.209_RE(3m)	Margin: 0
Probe: Horn_3117_00167055(1-18GHz)	Polarity: Vertical
EUT:LED LAMP	Power: AC 120V/60Hz
Note: Mode1:Transmit at 2405MHz by Zigbee	

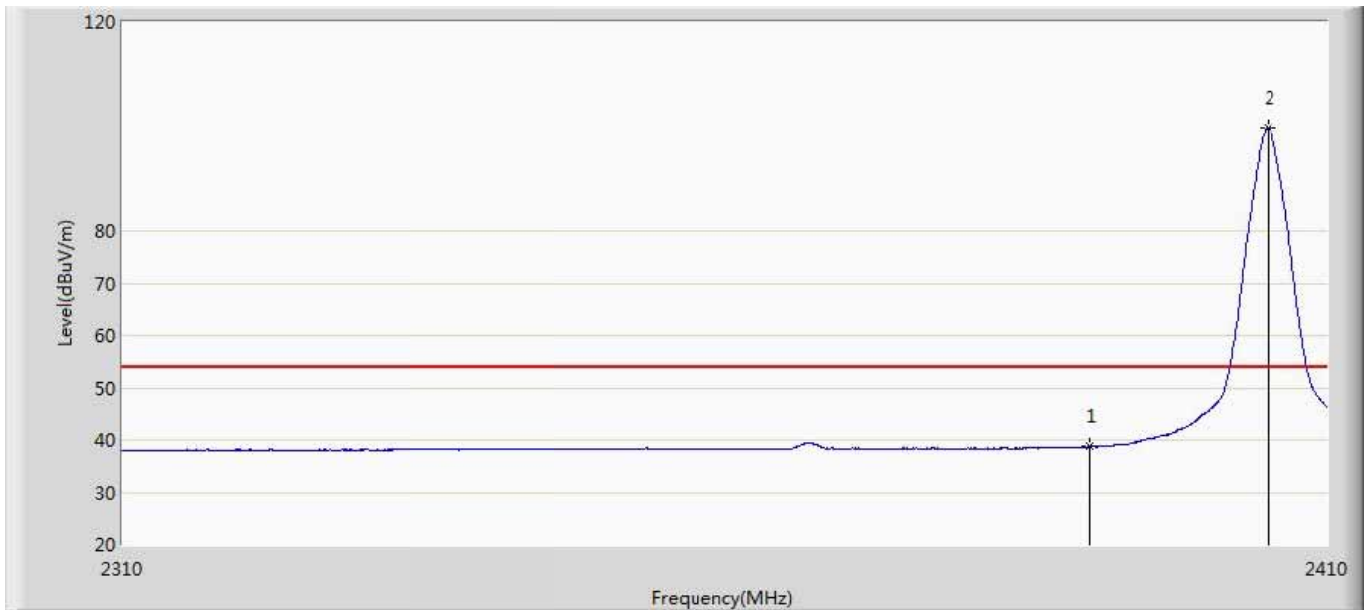

No	Mark	Frequency (MHz)	Measure Level (dBuV/m)	Reading Level (dBuV)	Over Limit (dB)	Limit (dBuV/m)	Factor (dB)	Type
1		2390.000	38.708	3.026	-15.292	54.000	35.682	AV
2	*	2405.000	99.846	64.125	45.846	54.000	35.721	AV

Engineer: YULIU	
Site: AC5	Time: 2019/04/13 - 10:30
Limit: FCC_Part15.209_RE(3m)	Margin: 0
Probe: Horn_3117_00167055(1-18GHz)	Polarity: Horizontal
EUT:LED LAMP	Power: AC 120V/60Hz
Note: Mode1:Transmit at 2405MHz by Zigbee	

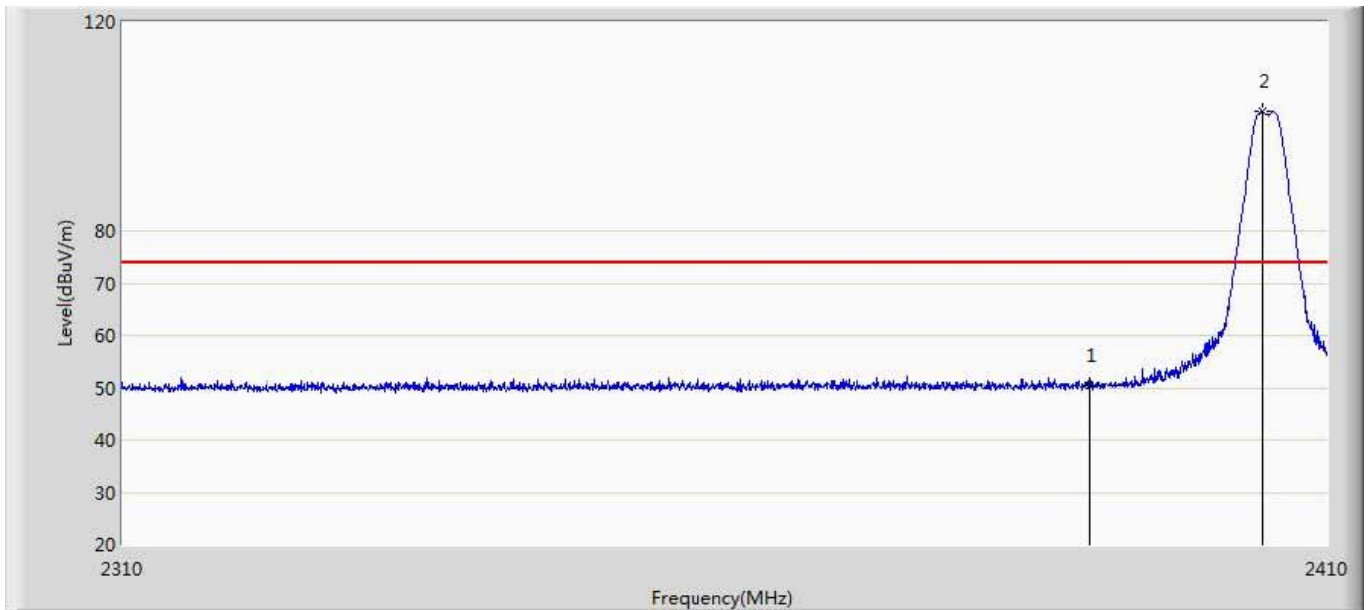

No	Mark	Frequency (MHz)	Measure Level (dBuV/m)	Reading Level (dBuV)	Over Limit (dB)	Limit (dBuV/m)	Factor (dB)	Type
1		2390.000	50.469	14.787	-23.531	74.000	35.682	PK
2	*	2404.500	102.806	67.087	28.806	74.000	35.719	PK

Engineer: YULIU	
Site: AC5	Time: 2019/04/13 - 10:32
Limit: FCC_Part15.209_RE(3m)	Margin: 0
Probe: Horn_3117_00167055(1-18GHz)	Polarity: Horizontal
EUT:LED LAMP	Power: AC 120V/60Hz
Note: Mode1:Transmit at 2405MHz by Zigbee	

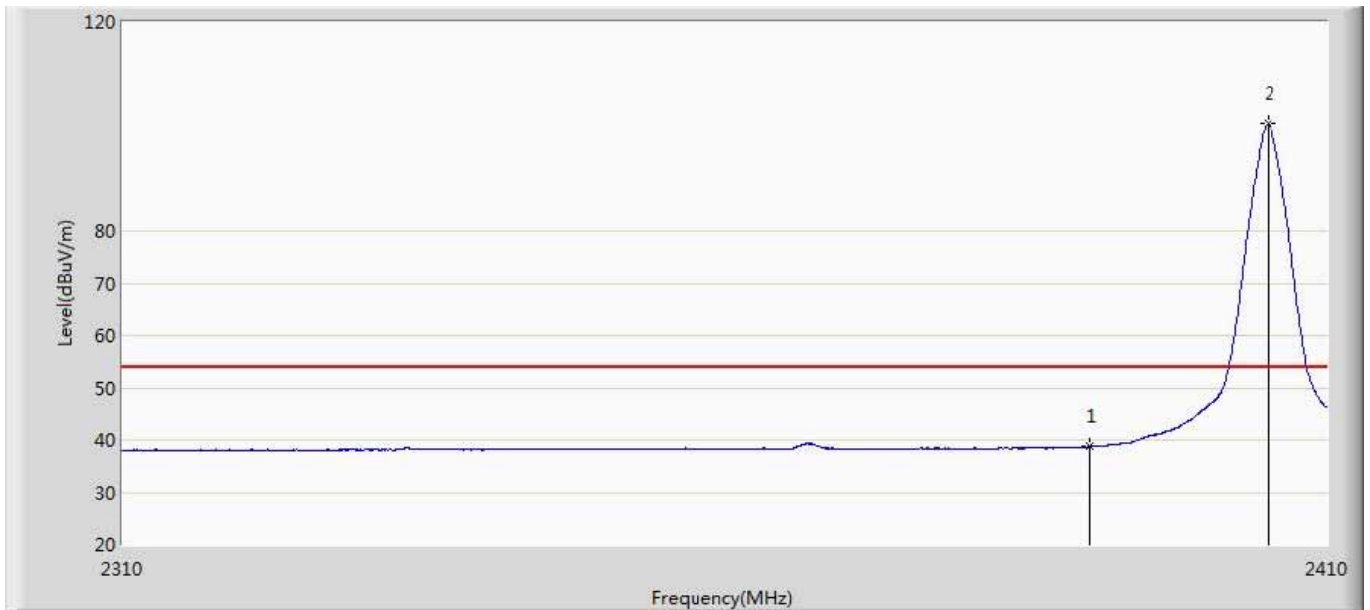

No	Mark	Frequency (MHz)	Measure Level (dBuV/m)	Reading Level (dBuV)	Over Limit (dB)	Limit (dBuV/m)	Factor (dB)	Type
1		2390.000	38.715	3.033	-15.285	54.000	35.682	AV
2	*	2405.000	100.448	64.727	46.448	54.000	35.721	AV

Engineer: YULIU	
Site: AC5	Time: 2019/04/13 - 10:34
Limit: FCC_Part15.209_RE(3m)	Margin: 0
Probe: Horn_3117_00167055(1-18GHz)	Polarity: Vertical
EUT:LED LAMP	Power: AC 120V/60Hz
Note: Mode1:Transmit at 2480MHz by Zigbee	

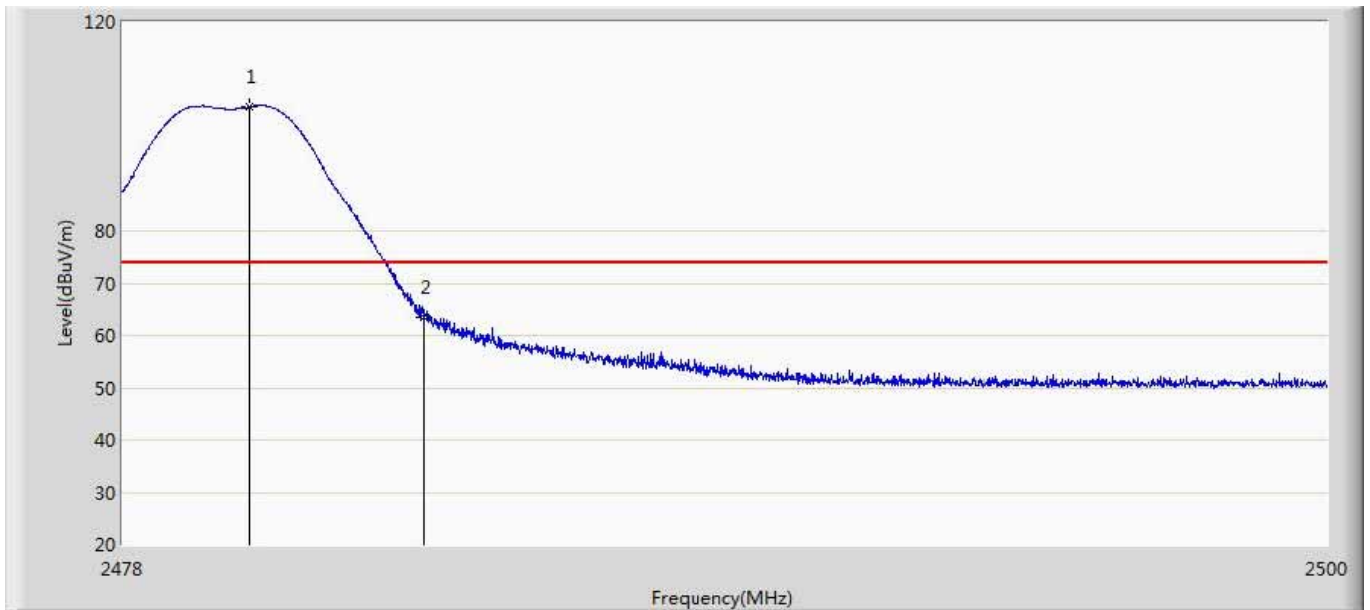

No	Mark	Frequency (MHz)	Measure Level (dBuV/m)	Reading Level (dBuV)	Over Limit (dB)	Limit (dBuV/m)	Factor (dB)	Type
1	*	2480.299	103.721	67.852	29.721	74.000	35.869	PK
2		2483.500	63.484	27.592	-10.516	74.000	35.891	PK

Engineer: YULIU	
Site: AC5	Time: 2019/04/13 - 10:36
Limit: FCC_Part15.209_RE(3m)	Margin: 0
Probe: Horn_3117_00167055(1-18GHz)	Polarity: Vertical
EUT:LED LAMP	Power: AC 120V/60Hz
Note: Mode1:Transmit at 2480MHz by Zigbee	

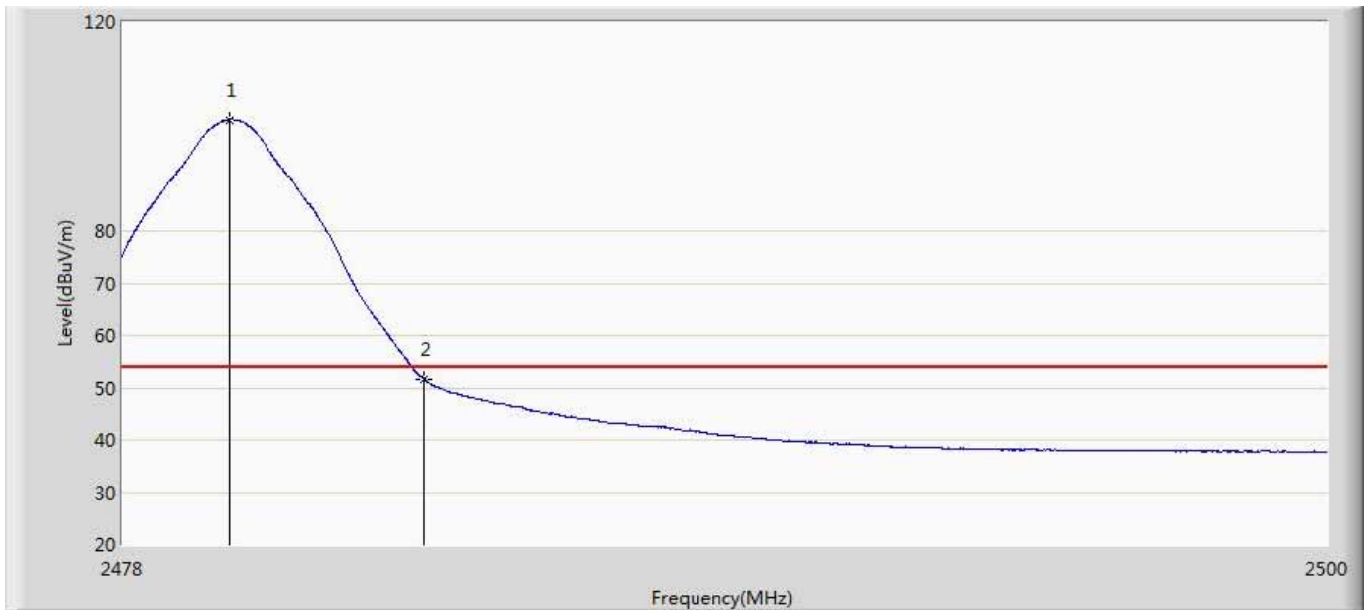

No	Mark	Frequency (MHz)	Measure Level (dBuV/m)	Reading Level (dBuV)	Over Limit (dB)	Limit (dBuV/m)	Factor (dB)	Type
1	*	2479.947	101.286	65.420	47.286	54.000	35.866	AV
2		2483.500	51.716	15.824	-2.284	54.000	35.891	AV

Engineer: YULIU	
Site: AC5	Time: 2019/04/13 - 10:38
Limit: FCC_Part15.209_RE(3m)	Margin: 0
Probe: Horn_3117_00167055(1-18GHz)	Polarity: Horizontal
EUT:LED LAMP	Power: AC 120V/60Hz
Note: Mode1:Transmit at 2480MHz by Zigbee	

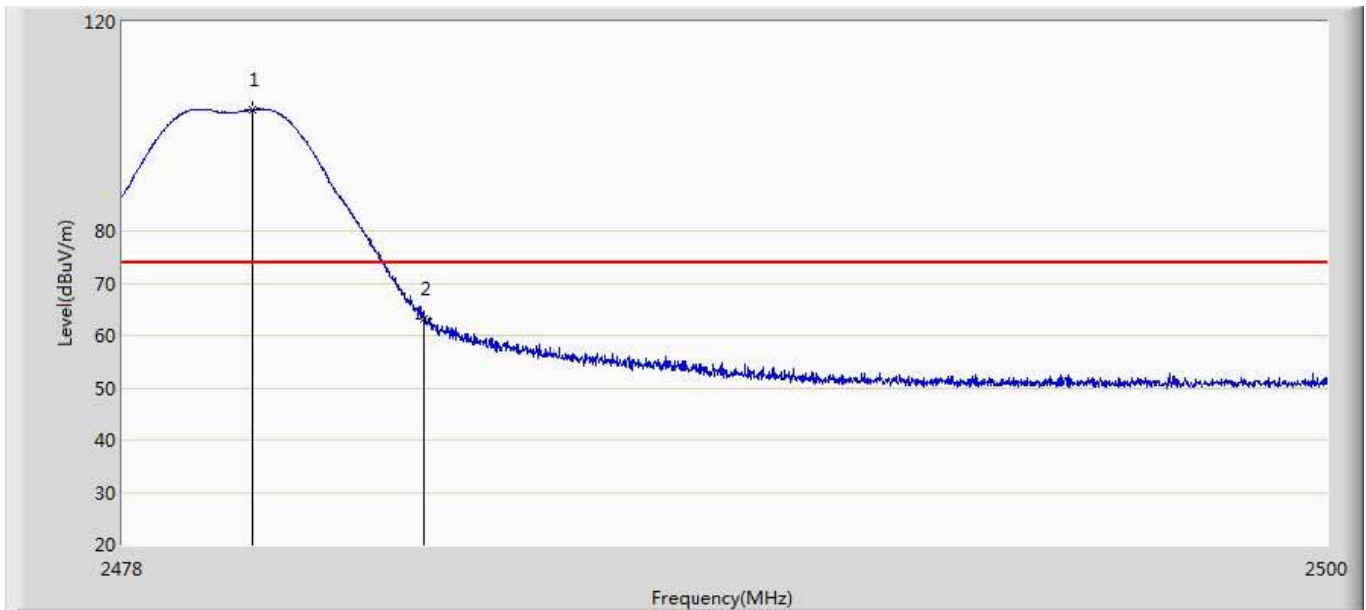

No	Mark	Frequency (MHz)	Measure Level (dBuV/m)	Reading Level (dBuV)	Over Limit (dB)	Limit (dBuV/m)	Factor (dB)	Type
1	*	2480.354	103.215	67.346	29.215	74.000	35.869	PK
2		2483.500	63.262	27.370	-10.738	74.000	35.891	PK

Engineer: YULIU	
Site: AC5	Time: 2019/04/13 - 10:39
Limit: FCC_Part15.209_RE(3m)	Margin: 0
Probe: Horn_3117_00167055(1-18GHz)	Polarity: Horizontal
EUT:LED LAMP	Power: AC 120V/60Hz
Note: Mode1:Transmit at 2480MHz by Zigbee	

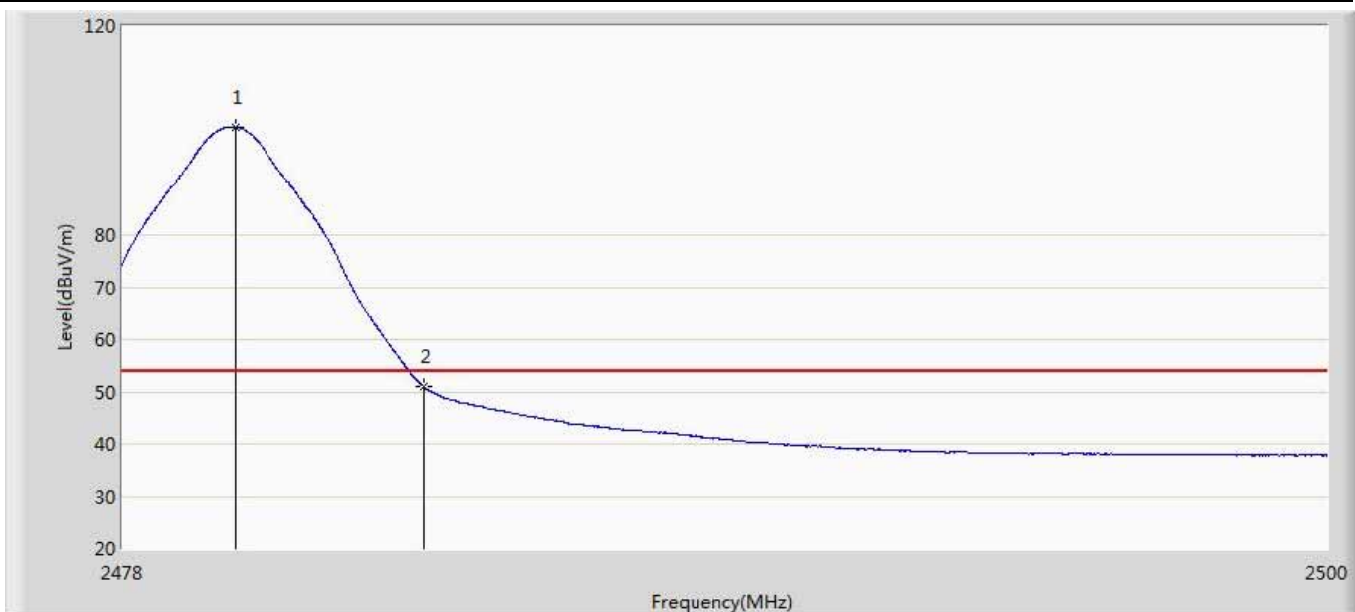

No	Mark	Frequency (MHz)	Measure Level (dBuV/m)	Reading Level (dBuV)	Over Limit (dB)	Limit (dBuV/m)	Factor (dB)	Type
1	*	2480.046	100.660	64.793	46.660	54.000	35.866	AV
2		2483.500	50.882	14.990	-3.118	54.000	35.891	AV

7. Occupied Bandwidth

7.1. Test Equipment

Occupied Bandwidth / TR-8					
Instrument	Manufacturer	Type No.	Serial No.	Cal. Date	Cal. Due Date
Spectrum Analyzer	Agilent	N9010A	MY48030494	2019.02.04	2020.02.03
EXA Spectrum Analyzer	Keysight	N9010A	MY55370495	2018.04.09	2019.04.08
MXA Signal Analyzer	Keysight	N9020A	MY56060147	2018.04.09	2019.04.08
Temperature/Humidity Meter	zhichen	ZC1-2	TR8-TH	2018.04.10	2019.04.09

Note: All equipments are calibrated with traceable calibrations. Each calibration is traceable to the national or international standards.

7.2. Test Setup

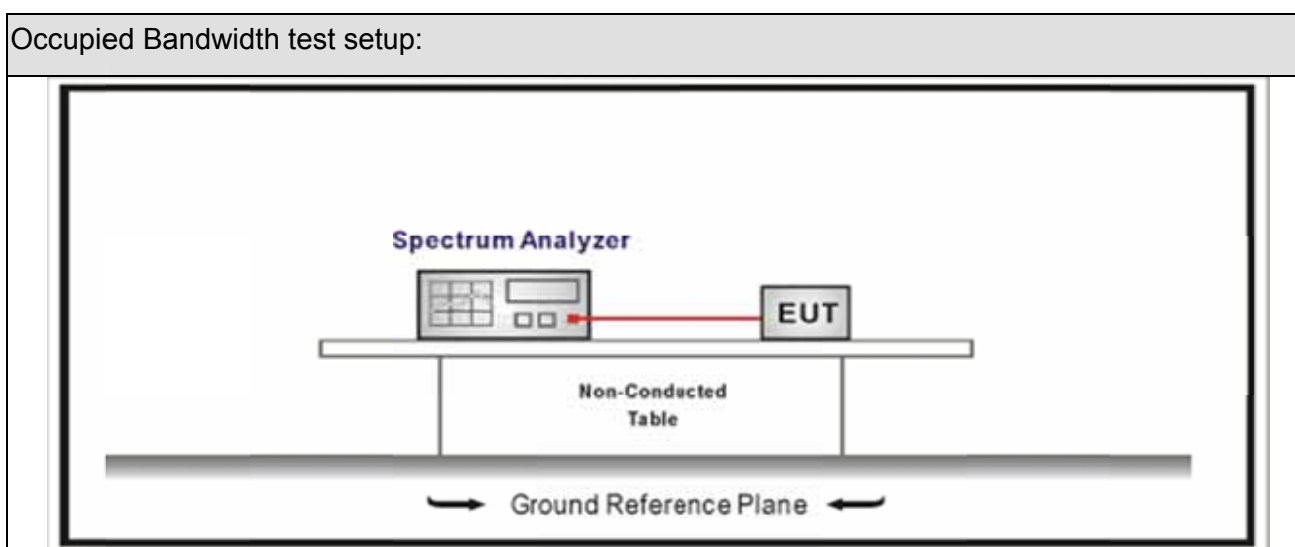





7.3. Limit

Occupied Bandwidth
Systems using digital modulation techniques operate in the 2400-2483.5 MHz. The minimum 6 dB bandwidth shall be at least 500 kHz

7.4. Test Procedure

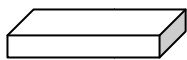
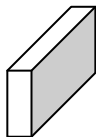
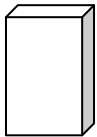
Test Method			
	Reference Rule	Chapter	Description
<input checked="" type="checkbox"/>	ANSI C63.10	11.8	DTS bandwidth
	<input type="checkbox"/> ANSI C63.10	11.8.1	Option 1
	<input checked="" type="checkbox"/> ANSI C63.10	11.8.2	Option 2

7.5. EUT test definition

Item	Occupied Bandwidth			
Device Category	<input type="checkbox"/>	Fixed point-to-point		
	<input type="checkbox"/>	Emit multiple directional beams, simultaneously or sequentially		
	<input checked="" type="checkbox"/>	Other cases		
Test mode	Mode 1			
Test method	<input type="checkbox"/>	Radiated		
		X Axis	Y Axis	Z Axis
				
		Worst Axis <input type="checkbox"/>	Worst Axis <input type="checkbox"/>	Worst Axis <input type="checkbox"/>
	<input checked="" type="checkbox"/>	Conducted		
	<input checked="" type="checkbox"/>	Chain 0		
				
	<input type="checkbox"/>	Chain 0	Chain 1	
				
	<input type="checkbox"/>	Chain 0	Chain 1	Chain 2
				

7.6. Test Result

Product Name	: LED lamp	Power	: AC 120V/60Hz
Test Mode	: Mode 1	Test Site	: TR-8
Test Date	: 2019.03.15		

Mode	CH.	Test Freq. (MHz)	99% Occupied Bandwidth (kHz)	Limit (kHz)	Result
1	11	2405	2253.0	>500	Pass
1	18	2440	2267.9	>500	Pass
1	39	2480	2284.7	>500	Pass

Mode 1 CH11 (2405MHz)



Mode 1 CH18 (2440MHz)

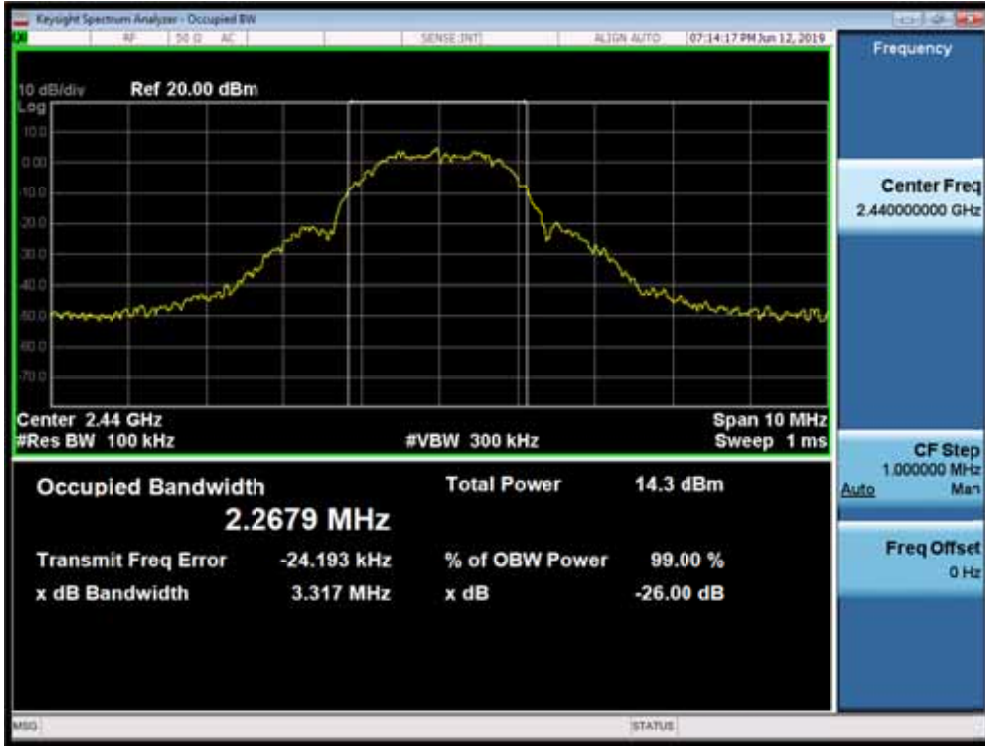

Mode 1 CH39 (2480MHz)

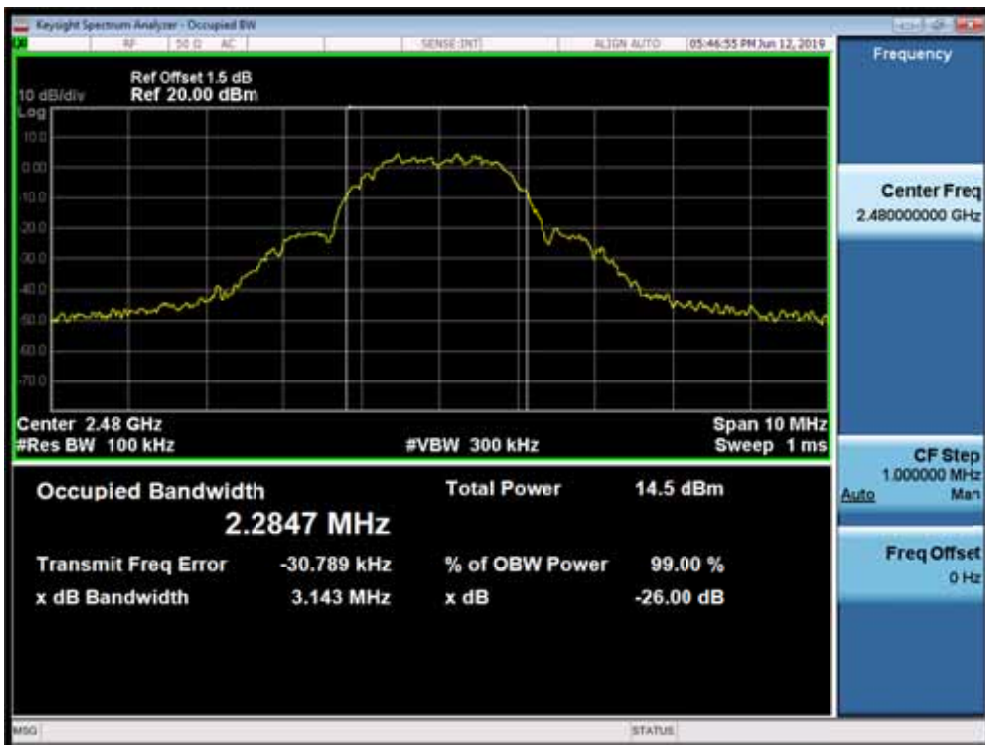

Mode	CH.	Test Freq. (MHz)	6dB Occupied Bandwidth (kHz)	Limit (kHz)	Result
1	11	2405	1722	>500	Pass
1	18	2440	1668	>500	Pass
1	26	2480	1723	>500	Pass

Note : The worst case of Occupied Bandwidth as below:

Mode 1 CH11 (2405MHz)



Mode 1 CH18 (2440MHz)



Mode 1 CH39 (2480MHz)



8. Fundamental emission output power

8.1. Test Equipment

Fundamental emission output power/ TR-8					
Instrument	Manufacturer	Type No.	Serial No.	Cal. Date	Cal. Due Date
Spectrum Analyzer	Agilent	E4446A	MY45300103	2019.01.04	2020.01.03
Spectrum Analyzer	Agilent	N9010A	MY48030494	2019.02.04	2020.01.15
Wideband Peak Power Meter	Anritsu	ML2495A	0905006	2018.10.14	2019.10.13
Power Sensor	Anritsu	MA2411B	0846014	2018.10.14	2019.10.13
Temperature/Humidity Meter	zhicheng	ZC1-2	TR8-TH	2018.04.10	2019.04.09

Note: All equipments are calibrated with traceable calibrations. Each calibration is traceable to the national or international standards.

8.2. Test Setup

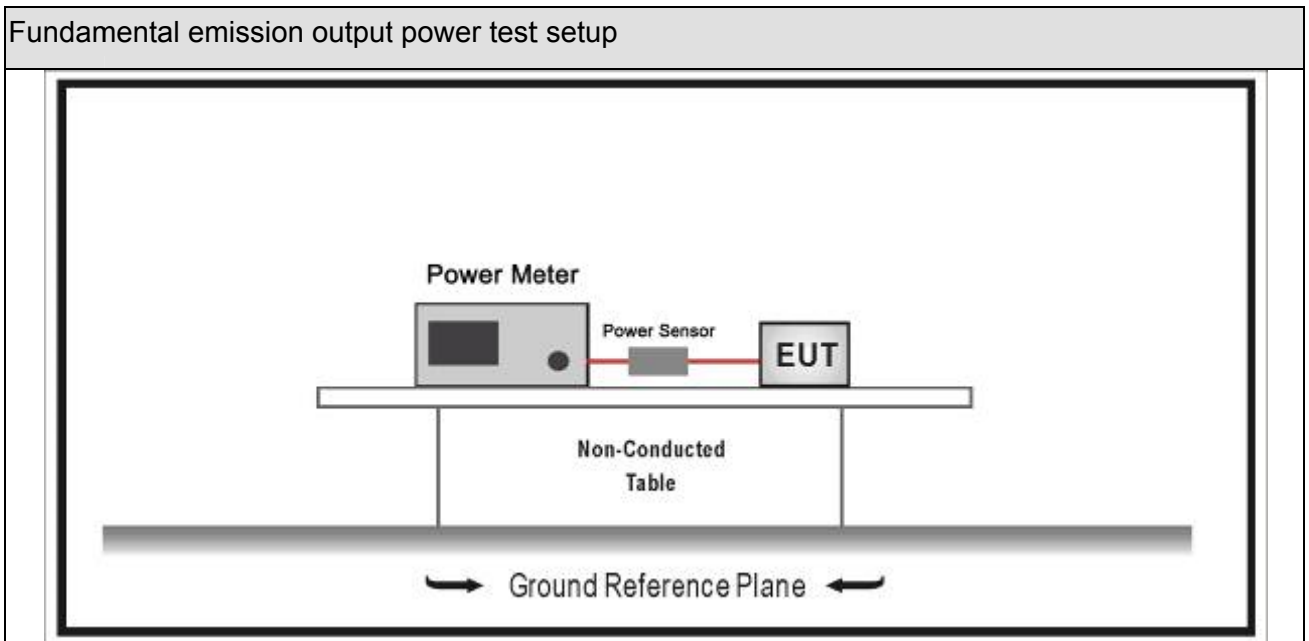



8.3. Limit

Fundamental emission output power Limit		
<input checked="" type="checkbox"/>	$G_{TX} < 6\text{dBi}$	$P_{out} \leq 30\text{dBm}$
<input type="checkbox"/>	$G_{TX} > 6\text{dBi}$	
<input type="checkbox"/>	Non-Fix point-point	$P_{out} \leq 30 - (G_{TX} - 6)$
<input type="checkbox"/>	Fix point-point	$P_{out} \leq 30 - [(G_{TX} - 6)]/3$
<input type="checkbox"/>	Point-to-multipoint	$P_{out} \leq 30 - (G_{TX} - 6)$
<input type="checkbox"/>	Overlap Beams	$P_{out} \leq 30 - [(G_{TX} - 6)]/3$
<input type="checkbox"/>	Aggregate power transmitted simultaneously on all beams	$P_{out} \leq 30 - [(G_{TX} - 6)]/3$
<input type="checkbox"/>	single directional beam	$P_{out} \leq 30 - [(G_{TX} - 6)]/3 + 8\text{dB}$
<p>Note 1 : G_{TX} directional gain of transmitting antennas.</p> <p>Note 2 : P_{out} is maximum peak conducted output power .</p>		

8.4. Test Procedure

Fundamental emission output power Test Method				
	References Rule		Chapter	Description
<input checked="" type="checkbox"/>	ANSI C63.10		11.9	Fundamental emission output power
	<input checked="" type="checkbox"/>	ANSI C63.10	11.9.1	Maximum peak conducted output power
	<input type="checkbox"/>	ANSI C63.10	11.9.1.1	RBW ≥ DTS bandwidth
	<input type="checkbox"/>	ANSI C63.10	11.9.1.2	Integrated band power method
	<input checked="" type="checkbox"/>	ANSI C63.10	11.9.1.3	PKPM1 Peak power meter method
	<input checked="" type="checkbox"/>	ANSI C63.10	11.9.2	Maximum conducted (average) output power
	<input type="checkbox"/>	ANSI C63.10	11.9.2.2	Measurement using a spectrum analyzer (SA)
	<input type="checkbox"/>	ANSI C63.10	11.9.2.2.2	Method AVGSA-1(Duty cycle 98%)
	<input type="checkbox"/>	ANSI C63.10	11.9.2.2.3	Method AVGSA-1A(Duty cycle 98%)
	<input type="checkbox"/>	ANSI C63.10	11.9.2.2.4	Method AVGSA-2(Duty cycle 98%)
	<input type="checkbox"/>	ANSI C63.10	11.9.2.2.5	Method AVGSA-2A(Duty cycle 98%)
	<input type="checkbox"/>	ANSI C63.10	11.9.2.2.4	Method AVGSA-3
	<input type="checkbox"/>	ANSI C63.10	11.9.2.2.5	Method AVGSA-3A
	<input checked="" type="checkbox"/>	ANSI C63.10	11.9.2.3	Measurement using a power meter (PM)
	<input checked="" type="checkbox"/>	ANSI C63.10	11.9.2.3.1	Method AVGPM
	<input type="checkbox"/>	ANSI C63.10	11.9.2.3.2	Method AVGPM-G

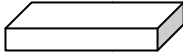
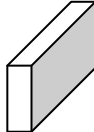
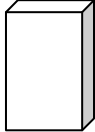
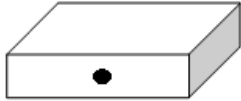
8.5. EUT test definition

Item	Fundamental emission output power			
Device Category	<input type="checkbox"/>	Fixed point-to-point		
	<input type="checkbox"/>	Emit multiple directional beams, simultaneously or sequentially		
	<input checked="" type="checkbox"/>	Other cases		
Test mode	Mode 1			
Test method	<input type="checkbox"/>	Radiated		
		X Axis	Y Axis	Z Axis
				
		Worst Axis <input type="checkbox"/>	Worst Axis <input type="checkbox"/>	Worst Axis <input type="checkbox"/>
	<input checked="" type="checkbox"/>	Conducted		
	<input checked="" type="checkbox"/>	Chain 0		
				
	<input type="checkbox"/>	Chain 0	Chain 1	
				
	<input type="checkbox"/>	Chain 0	Chain 1	Chain 2
				

8.6. Test Result

Product Name	: LED lamp	Power	: AC 120V/60Hz
Test Mode	: Mode 1	Test Site	: TR-8
Test Date	: 2019.03.16		

Muruta:

Mode	Channel	Test Frequency (MHz)	Measurement Power Output (dBm)	Limit (dBm)	Result
1	11	2405	11.32	30	Pass
1	18	2440	11.69	30	Pass
1	26	2480	11.83	30	Pass

Diodes:

Mode	Channel	Test Frequency (MHz)	Measurement Power Output (dBm)	Limit (dBm)	Result
1	11	2405	11.57	30	Pass
1	18	2440	12.11	30	Pass
1	26	2480	12.55	30	Pass

Kdx:

Mode	Channel	Test Frequency (MHz)	Measurement Power Output (dBm)	Limit (dBm)	Result
1	11	2405	11.25	30	Pass
1	18	2440	11.68	30	Pass
1	26	2480	11.84	30	Pass

9. Power Spectral Density

9.1. Test Equipment

Power Spectral Density / TR-8					
Instrument	Manufacturer	Type No.	Serial No.	Cal. Date	Cal. Due Date
Spectrum Analyzer	Agilent	N9010A	MY48030494	2019.02.04	2020.02.03
EXA Spectrum Analyzer	Keysight	N9010A	MY55370495	2018.04.09	2019.04.08
MXA Signal Analyzer	Keysight	N9020A	MY56060147	2018.04.09	2019.04.08
Temperature/Humidity Meter	zhichen	ZC1-2	TR8-TH	2018.04.10	2019.04.09

Note: All equipments are calibrated with traceable calibrations. Each calibration is traceable to the national or international standards.

9.2. Test Setup

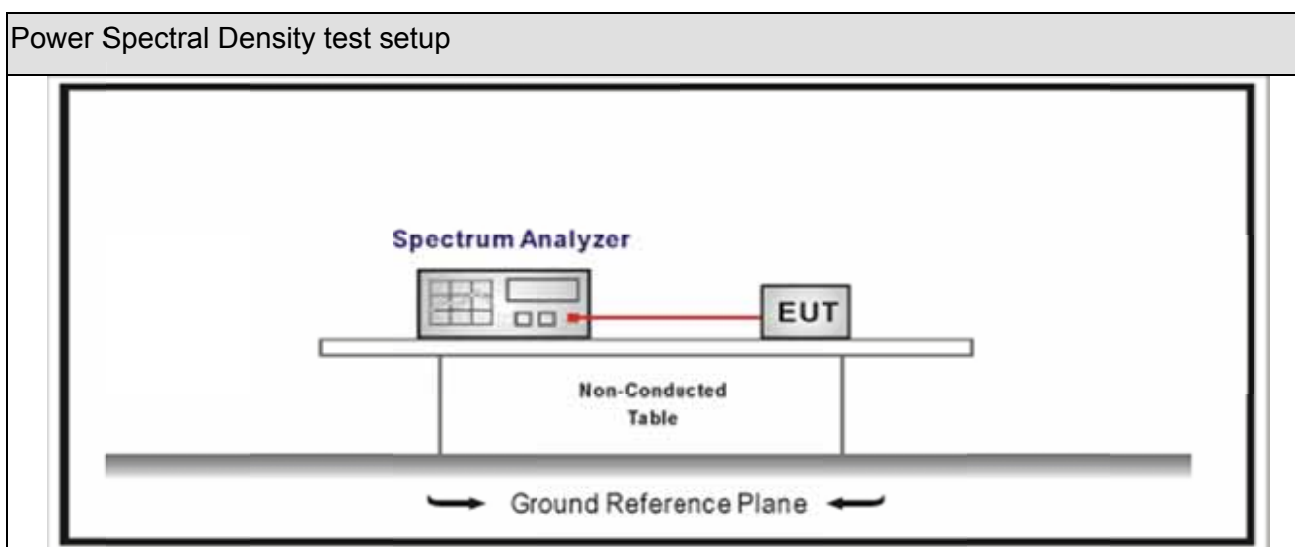



9.3. Limit

Power Spectral Density Limit
Power Spectral Density 8dBm/3kHz

9.4. Test Procedure

Power Spectral Density Test Method			
	References Rule	Chapter	Description
<input checked="" type="checkbox"/>	ANSI C63.10	11.10	Maximum power spectral density level in the fundamental emission
<input checked="" type="checkbox"/>	ANSI C63.10	11.10.2	Method PKPSD (peak PSD)
<input type="checkbox"/>	ANSI C63.10	11.10.3	Method AVGPSD-1(Duty cycle 98%)
<input type="checkbox"/>	ANSI C63.10	11.10.4	Method AVGPSD-1A(Duty cycle 98%)
<input type="checkbox"/>	ANSI C63.10	11.10.5	Method AVGPSD-2(Duty cycle < 98%)
<input type="checkbox"/>	ANSI C63.10	11.10.6	Method AVGPSD-2A(Duty cycle < 98%)
<input type="checkbox"/>	ANSI C63.10	11.10.7	Method AVGPSD-3
<input type="checkbox"/>	ANSI C63.10	11.10.8	Method AVGPSD-3A

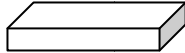
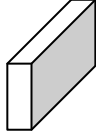
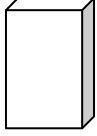
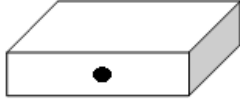
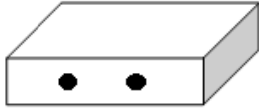
9.5. EUT test definition

Item	Power Spectral Density Test Method			
Device Category	<input type="checkbox"/>	Fixed point-to-point		
	<input type="checkbox"/>	Emit multiple directional beams, simultaneously or sequentially		
	<input checked="" type="checkbox"/>	Other cases		
Test mode	Mode 1			
Test method	<input type="checkbox"/>	Radiated		
		X Axis	Y Axis	Z Axis
				
		Worst Axis <input type="checkbox"/>	Worst Axis <input type="checkbox"/>	Worst Axis <input type="checkbox"/>
	<input checked="" type="checkbox"/>	Conducted		
	<input checked="" type="checkbox"/>	Chain 0		
				
	<input type="checkbox"/>	Chain 0	Chain 1	
				
	<input type="checkbox"/>	Chain 0	Chain 1	Chain 2
				

9.6. Test Result

Product Name	: LED lamp	Power	: AC 120V/60Hz
Test Mode	: Mode 1	Test Site	: TR-8
Test Date	: 2019.03.21		

Mode	Channel	Test Frequency (MHz)	Measurement PSD (dBm/3kHz)	Total PSD (dBm/3kHz)	Limit (dBm/3kHz)	Result
1	11	2405	-6.443	-6.443	8	Pass
1	18	2440	-6.010	-6.010	8	Pass
1	26	2480	-7.161	-7.161	8	Pass

Note : The worst case of Power Spectral Density as below:

Mode 1 CH20(2450MHz)



10. Antenna Requirement

10.1. Limit

Antenna Requirement Limit	
<p>An intentional radiator shall be designed to ensure that no antenna other than that furnished by the responsible party shall be used with the device. The use of a permanently attached antenna or of an antenna that uses a unique coupling to the intentional radiator shall be considered sufficient to comply with the provisions of this section. The manufacturer may design the unit so that a broken antenna can be replaced by the user, but the use of a standard antenna jack or electrical connector is prohibited. This requirement does not apply to carrier current devices or to devices operated under the provisions of §15.211, §15.213, §15.217, §15.219, or §15.221. Further, this requirement does not apply to intentional radiators that must be professionally installed, such as perimeter protection systems and some field disturbance sensors, or to other intentional radiators which, in accordance with §15.31(d), must be measured at the installation site. However, the installer shall be responsible for ensuring that the proper antenna is employed so that the limits in this part are not exceeded.</p>	

10.2. Antenna Connector Construction

Antenna Connector Construction	
<input checked="" type="checkbox"/>	The use of a permanently attached antenna
<input type="checkbox"/>	The antenna use of a unique coupling to the intentional radiator
<input type="checkbox"/>	The use of a nonstandard antenna jack or electrical connector
Please refer to the attached document "Internal Photograph" to show the antenna connector.	

_____ The End _____