



Test Report

FCC Part15 Subpart C & RSS-247 Issue 2

Product Name : LED lamp
Model No. : 9290019534
FCC ID : 2AGBW9290019534X
IC : 20812-9534X

Applicant : Signify (China) Investment Co., Ltd.

Address : Building no.9, Lane 888, Tianlin Road, Minhang District,
Shanghai 200233, China

Date of Receipt : Mar. 05, 2019
Test Date : Mar. 06, 2019~ Apr. 05, 2019
Issued Date : Apr. 17, 2019
Report No. : 1932050R-RF-US-P06V01
Report Version : V1.0

The test results relate only to the samples tested.

The test results shown in the test report are traceable to the national/international standard through the calibration of the equipment and evaluated measurement uncertainty herein.

This report must not be used to claim product endorsement by A2LA or any agency of the government.

The test report shall not be reproduced without the written approval of DEKRA Testing & Certification (Suzhou) Co., Ltd.

Test Report Certification

Issued Date : Apr. 17, 2019
Report No. : 1932050R-RF-US-P06V01



Product Name : LED lamp
 Applicant : Signify (China) Investment Co., Ltd.
 Address : Building no.9, Lane 888, Tianlin Road, Minhang District, Shanghai 200233, China
 Manufacturer : Signify (China) Investment Co., Ltd.
 Address : Building no.9, Lane 888, Tianlin Road, Minhang District, Shanghai 200233, China
 Model No. : 9290019534
 FCC ID : 2AGBW9290019534X
 IC : 20812-9534X
 EUT Voltage : 110-130 Vac, 50-60 Hz, 5.5W
 Test Voltage : AC 120V/60Hz
 Brand Name : PHILIPS
 Applicable Standard : FCC CFR Title 47 Part 15 Subpart C: 2017
 KDB 558074 D01v05
 RSS 247: Issue2; RSS GEN: Issue5
 ANSI C63.4:2014; ANSI C63.10:2013;
 Test Result : Complied
 Performed Location : DEKRA Testing and Certification (Suzhou) Co., Ltd.
 No.99 Hongye Rd., Suzhou Industrial Park, Suzhou, 215006, Jiangsu, China
 TEL: +86-512-6251-5088 / FAX: +86-512-6251-5098
 FCC Designation Number: CN1199; IC Lab Code: 4075B

Documented By : Kitty Li
 (Adm. Specialist: Kitty Li)

Reviewed By : Frank He
 (Senior Project Manager: Frank He)

Approved By : Jack Zhang
 (Engineering Supervisor: Jack Zhang)

TABLE OF CONTENTS

Description	Page
1. General Information.....	6
1.1. EUT Description	6
1.2. Working Frequency of Each Channel:	7
1.3. Antenna information	7
1.4. Mode of Operation.....	8
1.5. Tested System Details	8
1.6. Configuration of Tested System.....	9
1.7. EUT Exercise Software.....	10
2. Technical Test.....	11
2.1. Summary of Test Result.....	11
2.2. Test Environment.....	13
2.3. Measurement Uncertainty	13
3. AC Power Line Conducted Emission	14
3.1. Test Equipment.....	14
3.2. Test Setup.....	14
3.3. Limit.....	15
3.4. Test Procedure	15
3.5. Test Result.....	16
4. Emissions in restricted frequency bands	18
4.1. Test Equipment.....	18
4.2. Test Setup.....	19
4.3. Limit.....	20
4.4. Test Procedure	20
4.5. EUT test Axis definition.....	24
4.6. Test Result.....	25
5. Emissions in non-restricted frequency bands	45
5.1. Test Equipment.....	45
5.2. Test Setup.....	45
5.3. Limit.....	46
5.4. Test Procedure	47
5.5. EUT test Axis definition.....	48
5.6. Test Result.....	49
6. Radiated Emission Band Edge	50
6.1. Test Equipment.....	50
6.2. Test Setup.....	51
6.3. Limit.....	51
6.4. Test Procedure	52

- 6.5. EUT test definition 53
- 6.6. Duty Cycle 54
- 6.7. Test Result 55
- 7. Occupied Bandwidth 79
- 7.1. Test Equipment..... 79
- 7.2. Test Setup..... 79
- 7.3. Limit..... 80
- 7.4. Test Procedure 80
- 7.5. EUT test definition 81
- 7.6. Test Result..... 82
- 8. Fundamental emission output power 86
- 8.1. Test Equipment..... 86
- 8.2. Test Setup..... 86
- 8.3. Limit..... 87
- 8.4. Test Procedure 88
- 8.5. EUT test definition 89
- 8.6. Test Result..... 90
- 9. Power Spectral Density 91
- 9.1. Test Equipment..... 91
- 9.2. Test Setup..... 91
- 9.3. Limit..... 91
- 9.4. Test Procedure 92
- 9.5. EUT test definition 93
- 9.6. Test Result..... 94
- 10. Antenna Requirement..... 95
- 10.1. Limit..... 95
- 10.2. Antenna Connector Construction..... 95

History of This Test Report

REPORT NO.	VERSION	DESCRIPTION	ISSUED DATE
1932050R-RF-US-P06V01	V1.0	Initial Issued Report	Apr. 17, 2019

1. General Information

1.1. EUT Description

Product Name	LED lamp
Model No.	9290019534
EUT Voltage	110-130 Vac, 50-60 Hz, 5.5W
Test Voltage	AC 120V/60Hz
Zigbee	
Frequency Range	2405 ~ 2480MHz
Channel Number	16
Type of Modulation	DSSS-OQPSK
Data Rate	250kbps
Antenna Type	Reference to Antenna List

Note 1: LED lamp supports three kinds of Crystal oscillator (murata/ Diodes/kdx), there is not any change in RF design, circuitry or construction for this device, including RF parameters (antenna, software, firmware and hardware versions, power, frequency ranges, etc.), so only power, spurious emission and band-edge were tested for different crystal oscillator, the test data of worse mode is showed with other test items.

1.2. Working Frequency of Each Channel:

Zigbee Working Frequency of Each Channel:							
Channel	Frequency	Channel	Frequency	Channel	Frequency	Channel	Frequency
11	2405 MHz	12	2410 MHz	13	2415 MHz	14	2420 MHz
15	2425 MHz	16	2430 MHz	17	2435 MHz	18	2440 MHz
19	2445 MHz	20	2450 MHz	21	2455 MHz	22	2460 MHz
23	2465 MHz	24	2470 MHz	25	2475 MHz	26	2480 MHz

1.3. Antenna information

Antenna manufacturer	N/A						
Antenna Delivery	<input checked="" type="checkbox"/>	1*TX+1*RX	<input type="checkbox"/>	2*TX+2*RX	<input type="checkbox"/>	3*TX+3*RX	
Antenna technology	<input checked="" type="checkbox"/>	SISO					
	<input type="checkbox"/>	MIMO	<input type="checkbox"/>	Basic			
			<input type="checkbox"/>	CDD			
			<input type="checkbox"/>	Beam-forming			
Antenna Type	<input type="checkbox"/>	External	<input type="checkbox"/>	Dipole			
	<input checked="" type="checkbox"/>	Internal	<input type="checkbox"/>	PIFA			
			<input checked="" type="checkbox"/>	PCB			
			<input type="checkbox"/>	Ceramic Chip Antenna			
			<input type="checkbox"/>	Metal plate type F antenna			
Antenna Gain	1.5dBi						

1.4. Mode of Operation

Test Mode
Mode 1: Transmit

1.5. Tested System Details

The types for all equipment, plus descriptions of all cables used in the tested system (including inserted cards) are:

No.	Product	Manufacturer	Model No.	Serial No.	Power Cord
1	Notebook	Think Pad	2526	LV-A3285	Power by adapter
2	Zigbee Receiver	N/A	N/A	N/A	N/A
A	USB Control Cable	N/A	N/A	N/A	Shield, 1m
B	USB Control Cable	N/A	N/A	N/A	Shield, 10m

1.6. Configuration of Tested System

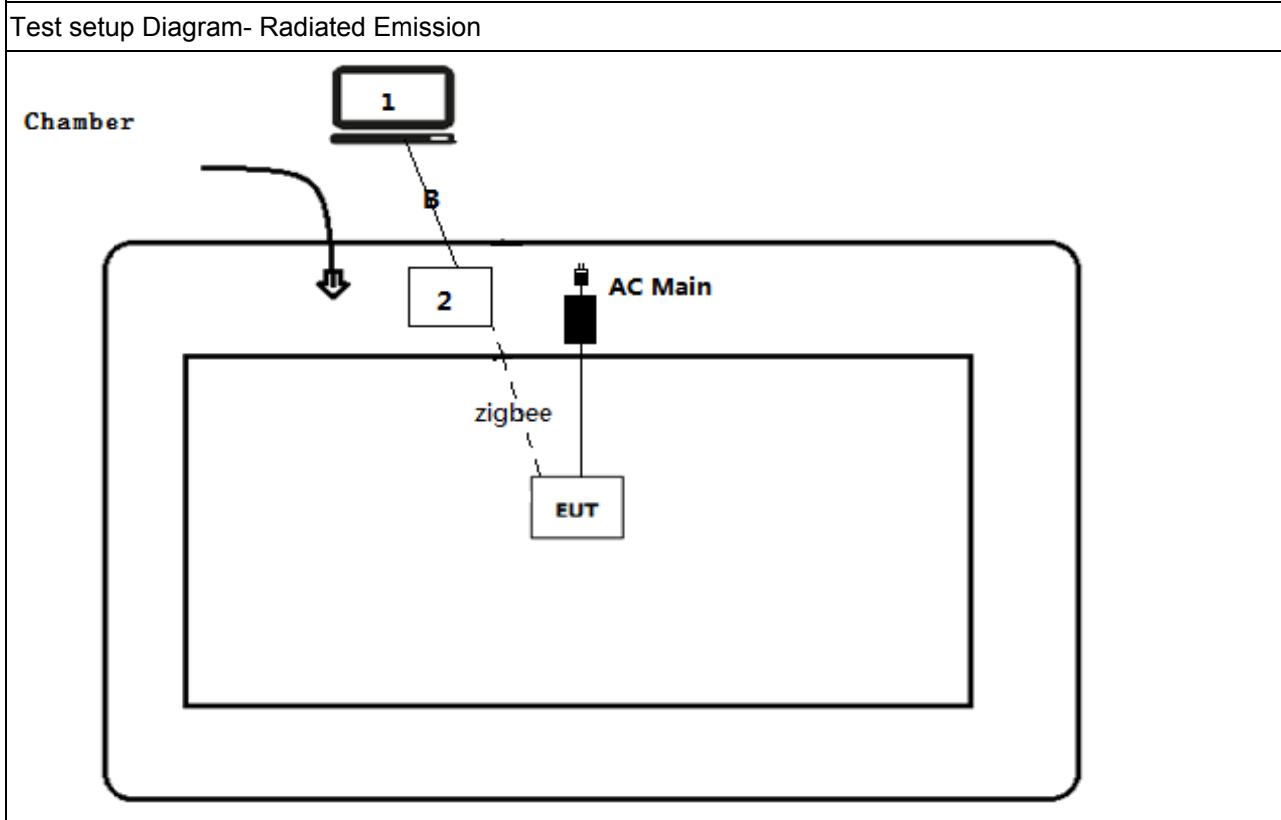
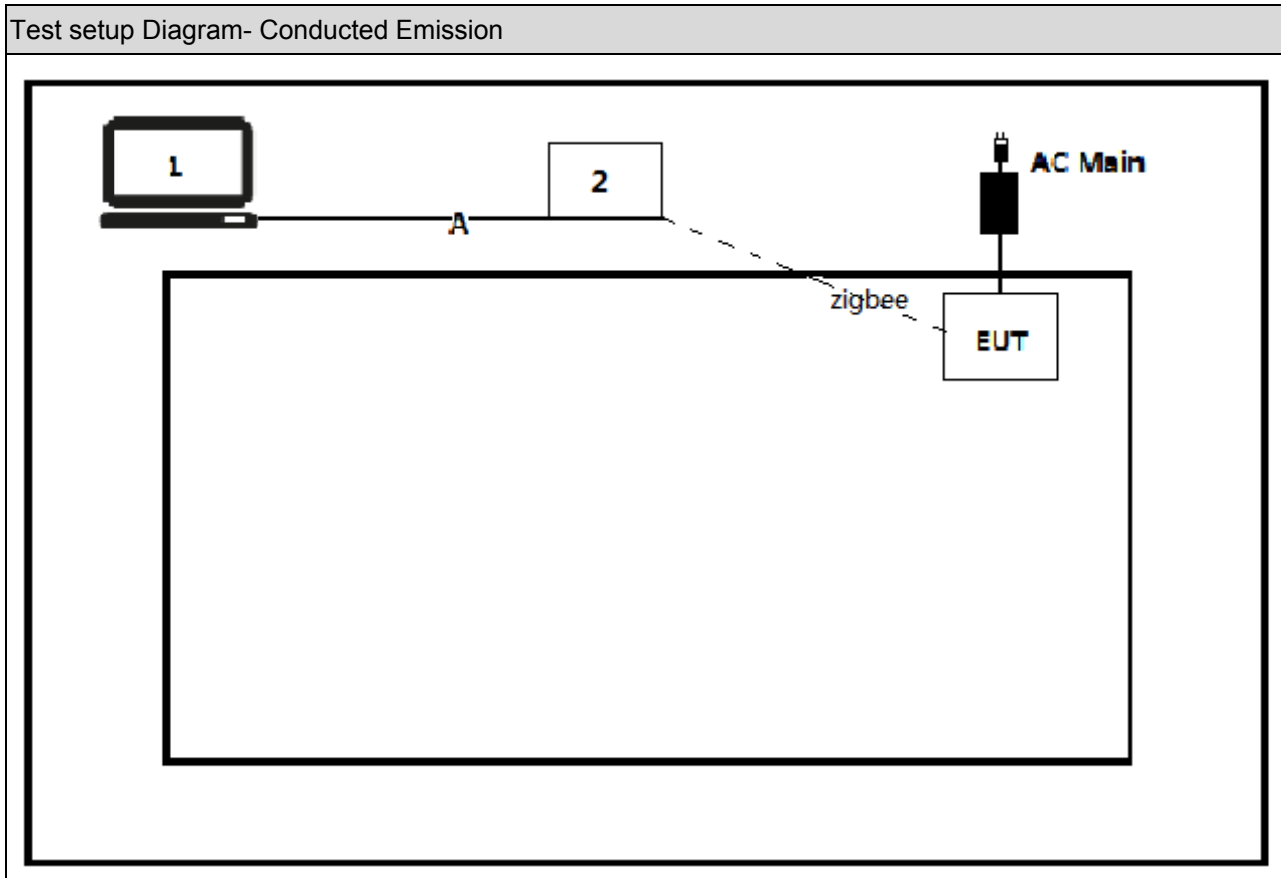

1.7. EUT Exercise Software

1	Setup the EUT and simulators as shown on above.
2	Turn on the power of equipment.
3	Run the test software (HueApprobaton Tool).
4	Select the transmission mode and test channel, then start test.

2. Technical Test

2.1. Summary of Test Result

FCC:

Performed Test Item	Normative References	Worst case mode	Limit	Result
AC Power Line Conducted Emission	FCC CFR Title 47 Part 15 Subpart C: 2015 Section 15.207	Mode 1	FCC 15.207	PASS
Emissions in restricted frequency bands	FCC CFR Title 47 Part 15 Subpart C: 2015 Section 15.209	Mode 1	FCC 15.209	PASS
Emissions in non-restricted frequency bands	FCC CFR Title 47 Part 15 Subpart C: 2015 Section 15.247(d)	Mode 1	20dBc	PASS
Radiated Emission Band Edge	FCC CFR Title 47 Part 15 Subpart C: 2015 15.247(d)	Mode 1	FCC 15.209	PASS
Occupied Bandwidth	FCC CFR Title 47 Part 15 Subpart C: 2015 Section 15.247(a)(2)	Mode 1	500kHz	PASS
Fundamental emission output power	FCC CFR Title 47 Part 15 Subpart C: 2015 Section 15.247(b)(3)	Mode 1	30dBm	PASS
Power Spectral Density	FCC CFR Title 47 Part 15 Subpart C: 2015 Section 15.247(e)	Mode 1	8dBm/3kHz	PASS
Antenna Requirement	FCC CFR Title 47 Part 15 Subpart C: 2015 Section 15.203	N/A	FCC 15.203	PASS

ISED:

Performed Test Item	Normative References	Worse case mode	Limit	Result
AC Power Line Conducted Emission	RSS-Gen Issue 4 November 2014 Section 8.8	N/A	RSS-Gen	PASS
Emissions in restricted frequency bands	RSS-247 Issue 1 May 2015 Section 5.5	Mode1	RSS-247	PASS
Emissions in non-restricted frequency bands	RSS-247 Issue 1 May 2015 Section 5.5	Mode1	30dBc	PASS
Radiated Emission Band Edge	RSS-Gen Issue 4 November 2014 Section 8.10	Mode1	RSS-Gen	PASS
Occupied Bandwidth	RSS-Gen Issue 4 November 2014 Section 6.6 RSS-247 Issue 1 May 2015 Section 5.2	Mode1	500kHz	PASS
Fundamental emission output power	RSS-247 Issue 1 May 2015 Section 5.4	Mode1	30dBm	PASS
Power Spectral Density	RSS-247 Issue 1 May 2015 Section 5.2	Mode1	8dBm/3kHz	PASS
Antenna Requirement	FCC CFR Title 47 Part 15 Subpart C: 2015 Section 15.203	N/A	RSS-Gen	PASS

2.2. Test Environment

Items	Required (IEC 68-1)	Actual
Temperature (°C)	15-35	21
Humidity (%RH)	25-75	50
Barometric pressure (mbar)	860-1060	950-1000

2.3. Measurement Uncertainty

Test Items	Uncertainty
AC Power Line Conducted Emission	$\pm 2.02\text{dB}$
Radiated Emission	Below 1GHz $\pm 3.8\text{ dB}$
	Above 1GHz $\pm 3.9\text{ dB}$
RF Antenna Port Conducted Emission	$\pm 1.27\text{dB}$
Radiated Emission Band Edge	$\pm 3.9\text{dB}$
Occupied Bandwidth	$\pm 1\text{kHz}$
Power Spectral Density	$\pm 1.27\text{dB}$

3. AC Power Line Conducted Emission

3.1. Test Equipment

AC Power Line Conducted Emission / TR-1					
Instrument	Manufacturer	Type No.	Serial No.	Cal. Date	Cal. Due Date
EMI Test Receiver	R&S	ESCI	100906	2019.03.05	2020.03.04
Two-Line V-Network	R&S	ENV 216	101189	2018.07.16	2019.07.15
Two-Line V-Network	R&S	ENV 216	101044	2018.09.16	2019.09.15
50ohm Coaxial Switch	Anritsu	MP59B	6200464462	N/A	N/A
50ohm Termination	SHX	TF2	07081402	2018.09.16	2019.09.15
Temperature/Humidity Meter	Zhichen	ZC1-2	TR1-TH	2019.01.05	2020.01.04

Note: All equipments are calibrated with traceable calibrations. Each calibration is traceable to the national or international standards.

3.2. Test Setup

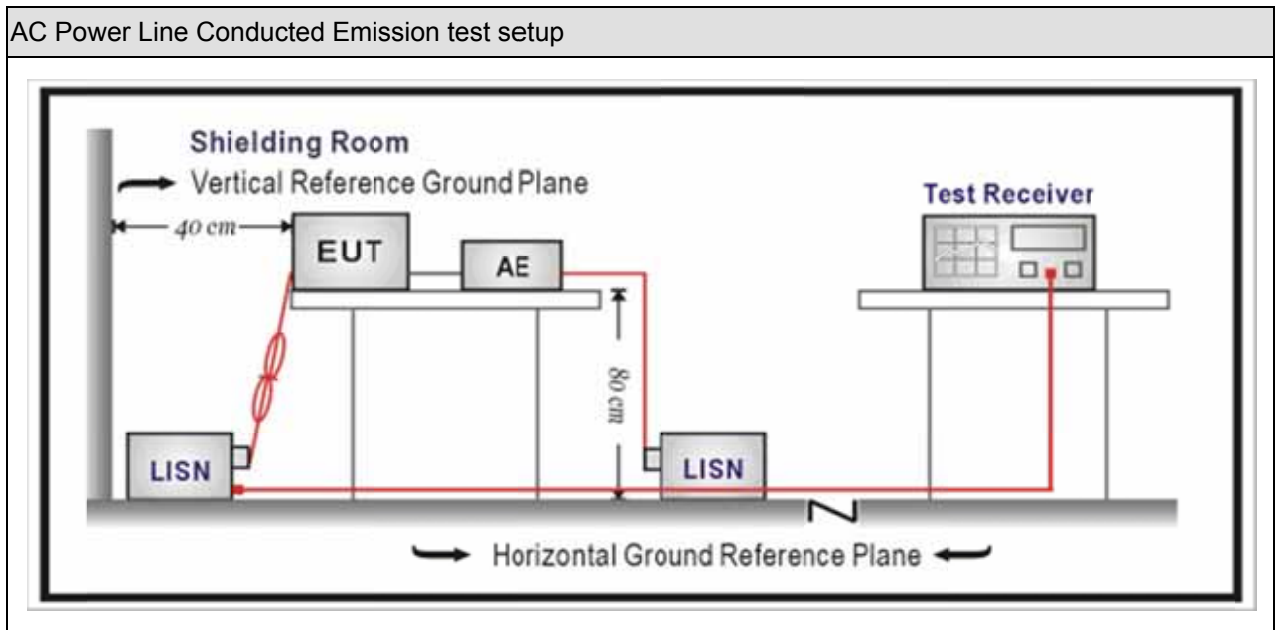

3.3. Limit

Frequency of Emission (MHz)	Conducted Limit	
	Quasi-peak (dB μ V)	Average (dB μ V)
0.15-0.5	66 to 56	56 to 46
0.5-5	56	46
5-30	60	50

Note 1: The lower limit shall apply at the transition frequencies.
 Note 2: The limit decreases linearly with the logarithm of the frequency in the range 0.15 MHz to 0.5 MHz.

3.4. Test Procedure

Test Method			
	References Rule	Chapter	Item
<input checked="" type="checkbox"/>	ANSI C63.10-2013	6.2	Standard test method for ac power-line conducted emissions from unlicensed wireless devices
<input checked="" type="checkbox"/>	ANSI C63.4-2014	7	AC power-line conducted emission measurements

3.5. Test Result

Engineer: LiuYu	
Site: TR1	Time: 2019/04/13 - 11:10
Limit: FCC_Part15.107_CE_AC Power_ClassB	Margin: 4
Probe: ENV216_101190(0.009-30MHz)	Polarity: Neutral
EUT: LED LAMP	Power: AC 120V/60Hz
Note: Mode 1	

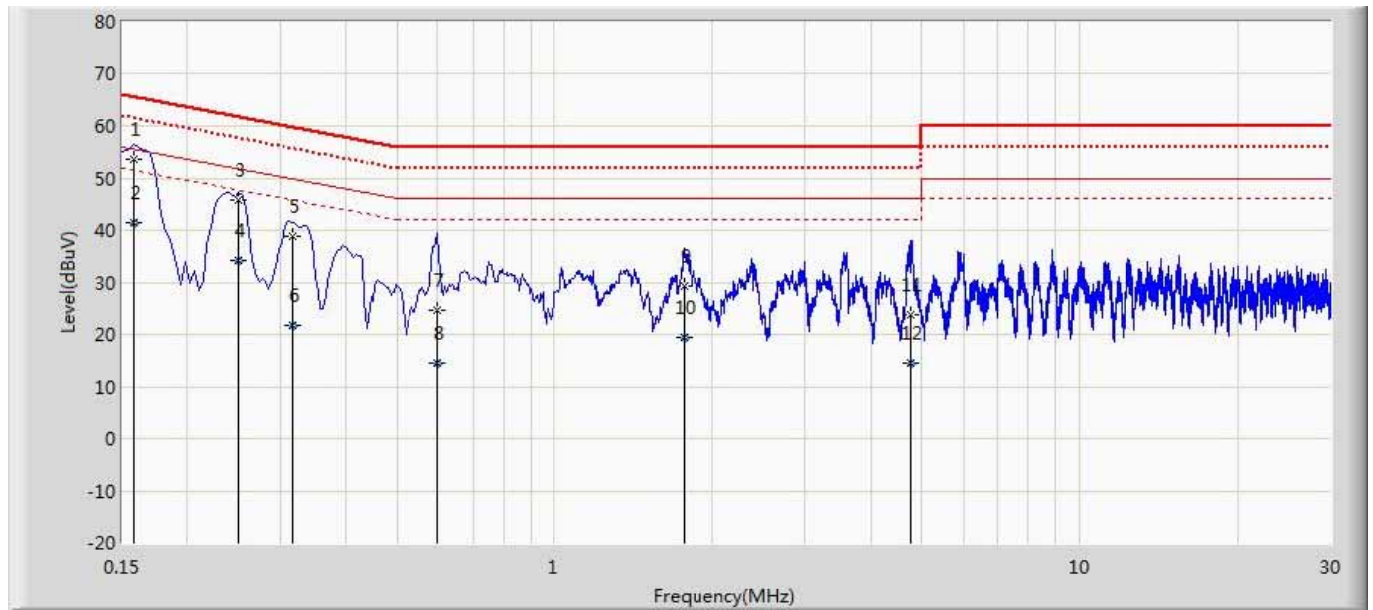

No	Mark	Frequency (MHz)	Measure Level (dBuV)	Reading Level (dBuV)	Over Limit (dB)	Limit (dBuV)	Factor (dB)	Type
1	*	0.158	53.710	44.095	-11.877	65.587	9.614	QP
2		0.158	41.545	31.931	-14.042	55.587	9.614	AV
3		0.250	45.932	36.303	-15.825	61.757	9.628	QP
4		0.250	34.207	24.578	-17.551	51.757	9.628	AV
5		0.318	38.723	29.095	-21.036	59.759	9.628	QP
6		0.318	21.603	11.975	-28.156	49.759	9.628	AV
7		0.598	24.629	14.991	-31.371	56.000	9.638	QP
8		0.598	14.385	4.747	-31.615	46.000	9.638	AV
9		1.758	29.153	19.462	-26.847	56.000	9.690	QP
10		1.758	19.558	9.867	-26.442	46.000	9.690	AV
11		4.770	23.696	13.907	-32.304	56.000	9.789	QP
12		4.770	14.598	4.809	-31.402	46.000	9.789	AV

Note:

1. " * ", means this data is the worst emission level.
2. Measurement Level = Reading Level + Factor(Probe+Cable-Amp).

Engineer: LiuYu	
Site: TR1	Time: 2019/04/13 - 12:18
Limit: FCC_Part15.107_CE_AC Power_ClassB	Margin: 4
Probe: ENV216_101190(0.009-30MHz)	Polarity: Line
EUT: LED LAMP	Power: AC 120V/60Hz
Note: Mode 1	

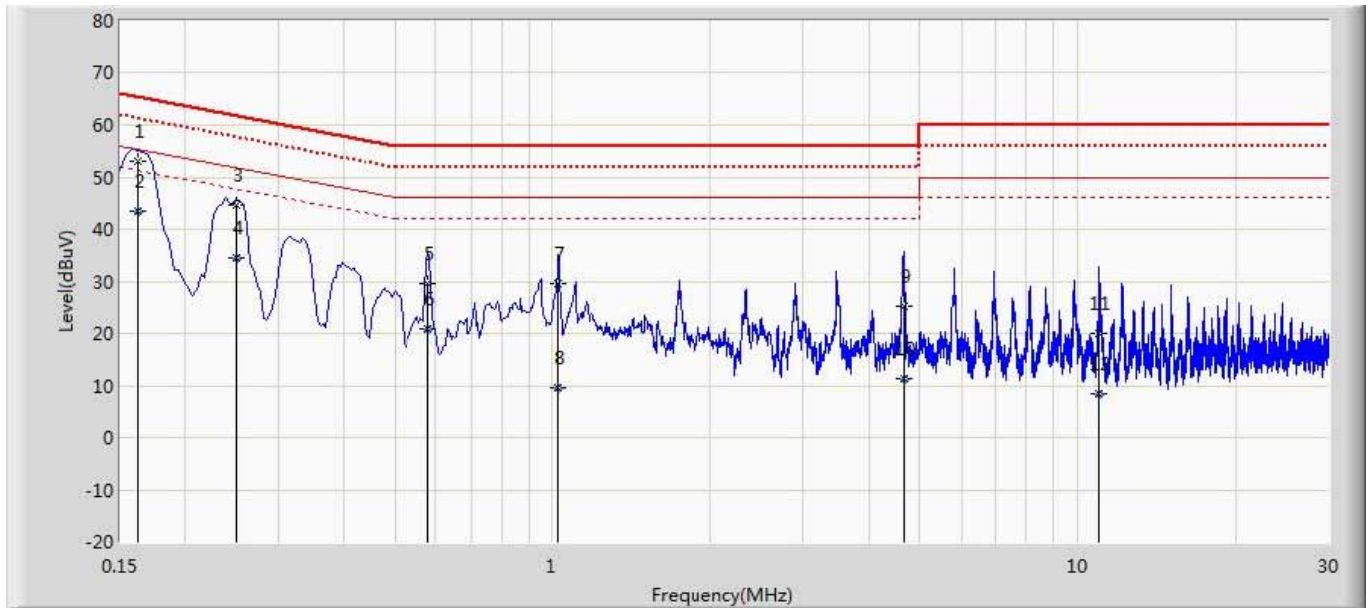

No	Mark	Frequency (MHz)	Measure Level (dBuV)	Reading Level (dBuV)	Over Limit (dB)	Limit (dBuV)	Factor (dB)	Type
1		0.162	52.908	43.278	-12.472	65.380	9.630	QP
2	*	0.162	43.345	33.715	-12.035	55.380	9.630	AV
3		0.250	44.700	35.070	-17.057	61.757	9.630	QP
4		0.250	34.486	24.856	-17.271	51.757	9.630	AV
5		0.578	29.649	20.004	-26.351	56.000	9.645	QP
6		0.578	20.745	11.099	-25.255	46.000	9.645	AV
7		1.026	29.690	20.013	-26.310	56.000	9.677	QP
8		1.026	9.588	-0.089	-36.412	46.000	9.677	AV
9		4.654	25.345	15.554	-30.655	56.000	9.790	QP
10		4.654	11.416	1.626	-34.584	46.000	9.790	AV
11		10.986	20.046	10.033	-39.954	60.000	10.013	QP
12		10.986	8.431	-1.582	-41.569	50.000	10.013	AV

Note:

1. " * ", means this data is the worst emission level.
2. Measurement Level = Reading Level + Factor(Probe+Cable-Amp).

4. Emissions in restricted frequency bands

4.1. Test Equipment

Radiated Emission(Below 1GHz) / AC-2					
Instrument	Manufacturer	Type No.	Serial No.	Cal. Date	Cal. Due Date
EMI Test Receiver	R&S	ESCI	100573	2019.03.29	2020.03.28
Loop Antenna	R&S	HFH2-Z2	833799/003	2018.11.16	2019.11.15
Bilog Antenna	Teseq GmbH	CBL6112D	27611	2018.10.16	2019.10.15
Coaxial Cable	Huber+Suhner	SUCOFLEX 106	AC2-C	2019.03.02	2020.03.01
Temperature/Humidity Meter	Zhichen	ZC1-2	AC2-TH	2019.01.04	2020.01.03
Note: All equipments are calibrated with traceable calibrations. Each calibration is traceable to the national or international standards.					

Radiated Emission(Above 1GHz) / AC-5					
Instrument	Manufacturer	Type No.	Serial No.	Cal. Date	Cal. Due Date
Spectrum Analyzer	Agilent	E4446A	MY45300103	2019.01.04	2020.01.03
Preamplifier	Miteq	NSP1800-25	1364185	2018.05.06	2019.05.05
Preamplifier	QuieTek	AP-040G	CHM-0906001	2018.05.06	2019.05.05
DRG Horn	ETS-Lindgren	3117	00123988	2019.01.22	2020.01.21
Broad-Band Horn Antenna	Schwarzbeck	BBHA9170	294	2018.11.25	2019.11.24
Coaxial Cable	Huber+Suhner	SUCOFLEX 106	AC5-C1	2019.03.02	2020.03.01
Coaxial Cable	Huber+Suhner	SUCOFLEX 106	AC5-C2	2019.03.02	2020.03.01
Coaxial Cable	Huber+Suhner	SUCOFLEX 102	AC5-C3	2019.03.02	2020.03.01
EMI Receiver	Agilent	N9038A	MY51210196	2018.06.10	2019.06.09
Temperature/Humidity Meter	Zhichen	ZC1-2	AC5-TH	2019.01.04	2020.01.03
Note: All equipments are calibrated with traceable calibrations. Each calibration is traceable to the national or international standards.					

4.2. Test Setup

Below 30MHz Test Setup:

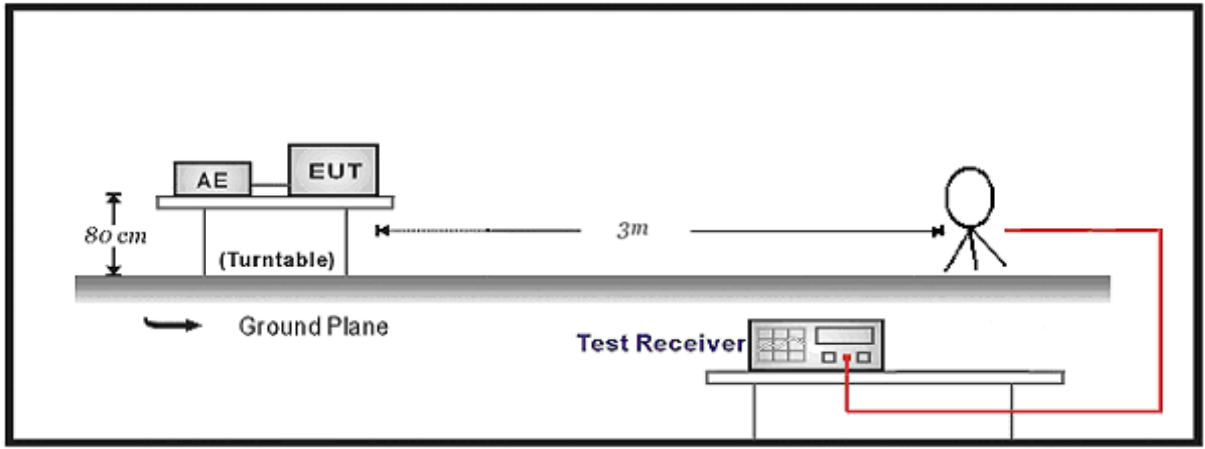

30MHz-1GHz Test Setup:

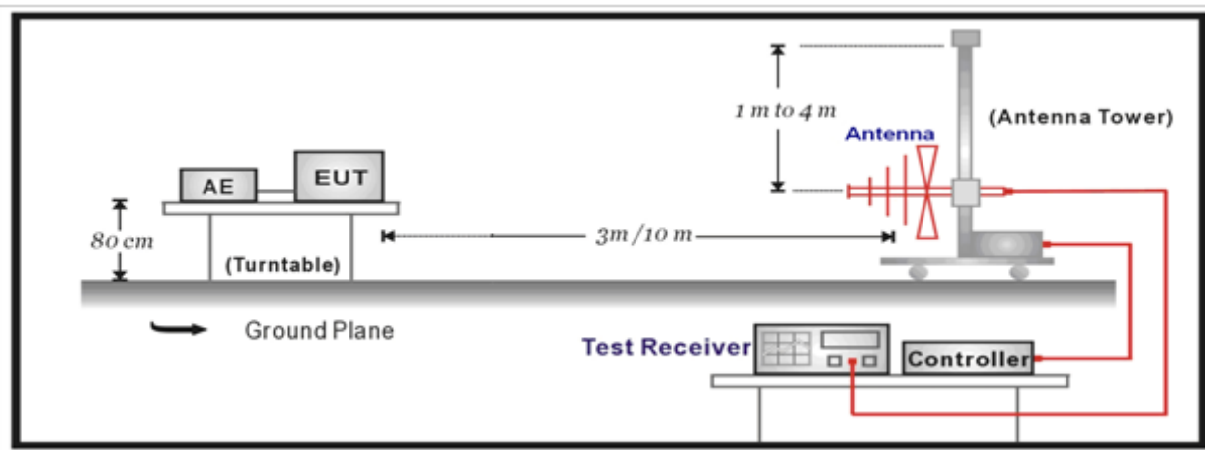

Above 1GHz Test Setup:

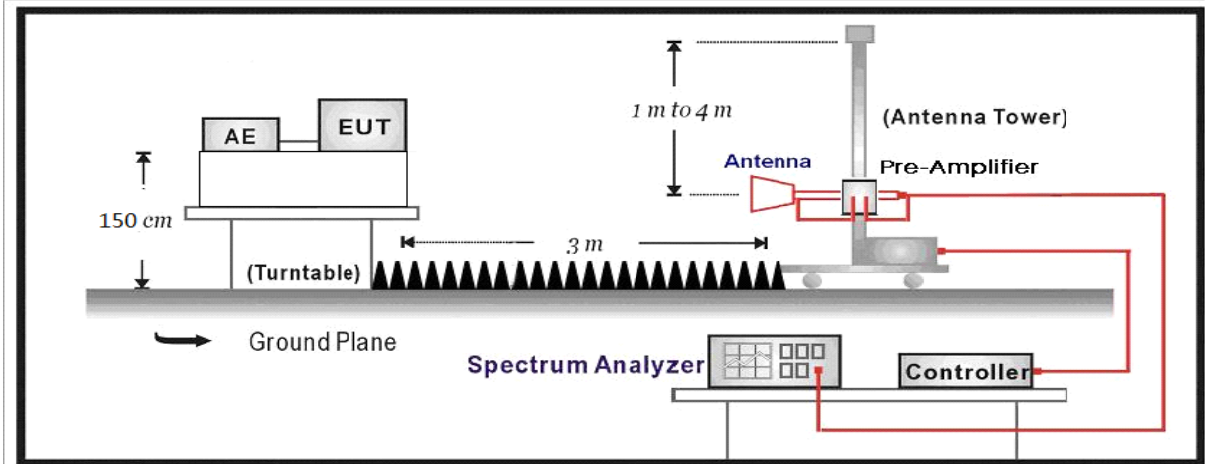

4.3. Limit

For FCC:

Restricted Bands of operation			
Frequency (MHz)	Frequency (MHz)	Frequency (MHz)	Frequency (GHz)
0.090 – 0.110	16.42 – 16.423	399.9 – 410	4.5 – 5.15
0.495 – 0.505	16.69475 – 16.69525	608 – 614	5.35 – 5.46
2.1735 – 2.1905	16.80425 – 16.80475	960 – 1240	7.25 – 7.75
4.125 – 4.128	25.5 – 25.67	1300 – 1427	8.025 – 8.5
4.17725 – 4.17775	37.5 – 38.25	1435 – 1626.5	9.0 – 9.2
4.20725 – 4.20775	73 – 74.6	1645.5 – 1646.5	9.3 – 9.5
6.215 – 6.218	74.8 – 75.2	1660 – 1710	10.6 – 12.7
6.26775 – 6.26825	108 – 121.94	1718.8 – 1722.2	13.25 – 13.4
6.31175 – 6.31225	123 – 138	2200 – 2300	14.47 – 14.5
8.291 – 8.294	149.9 – 150.05	2310 – 2390	15.35 – 16.2
8.362 – 8.366	156.52475 – 156.52525	2483.5 – 2500	17.7 – 21.4
8.37625 – 8.38675	156.7 – 156.9	2690 – 2900	22.01 – 23.12
8.81425 – 8.81475	162.0125 – 167.17	3260 – 3267	23.6 – 24.0
12.29 – 12.293	167.72 – 173.2	3332 – 3339	31.2 – 31.8
12.51975 – 12.52025	240 – 285	3345.8 – 3358	36.43 – 36.5
12.57675 – 12.57725	322 – 335.4	3600 – 4400	
13.36 – 13.41			

For ISED:

Restricted Bands of operation			
Frequency (MHz)	Frequency (MHz)	Frequency (MHz)	Frequency (GHz)
	13.36 - 13.41	960 - 1427	9.0 - 9.2
0.495 - 0.505	16.42 - 16.423	1435 - 1626.5	9.3 - 9.5
2.1735 - 2.1905	16.69475 - 16.69525	1645.5 - 1646.5	10.6 - 12.7
3.020 - 3.026	16.80425 - 16.80475	1660 - 1710	13.25 - 13.4
4.125 - 4.128	25.5 - 25.67	1718.8 - 1722.2	14.47 - 14.5
4.17725 - 4.17775	37.5 - 38.25	2200 - 2300	15.35 - 16.2
4.20725 - 4.20775	73 - 74.6	2310 - 2390	17.7 - 21.4
5.677 - 5.683	74.8 - 75.2	2483.5 - 2500	22.01 - 23.12
6.215 - 6.218	108 - 138	2655 - 2900	23.6 - 24.0
6.26775 - 6.26825	149.9 - 150.05	3260 - 3267	31.2 - 31.8
6.31175 - 6.31225	156.52475 - 156.52525	3332 - 3339	36.43 - 36.5
8.291 - 8.294	156.7 - 156.9	3345.8 - 3358	Above 38.6
8.362 - 8.366	162.0125 - 167.17	3500 - 4400	
8.37625 - 8.38675	167.72 - 173.2	4500 - 5150	
8.41425 - 8.41475	240 - 285	5350 - 5460	
12.29 - 12.293	322 - 335.4	7250 - 7750	
12.51975 - 12.52025	399.9 - 410	8025 - 8500	
12.57675 - 12.57725	608 - 614	--	

Restricted Band Emissions Limit			
Frequency (MHz)	Field strength (μ V/m)	Field strength (dB μ V/m)	Measurement distance (m)
0.009 - 0.49	2400/F(kHz)	48.5 – 13.8	300 _(Note 1)
0.49 - 1.705	24000/F(kHz)	33.8 - 23	30 _(Note 1)
1.705 - 30	30	29.5	30 _(Note 1)
30 - 88	100	40	3 _(Note 2)
88 - 216	150	43.5	3 _(Note 2)
216 - 960	200	46	3 _(Note 2)
Above 960	500	54	3 _(Note 2)



Note 1: At frequencies below 30 MHz, measurements may be performed at a distance closer than that specified in the regulations; however, an attempt should be made to avoid making measurements in the near field. Pending the development of an appropriate measurement procedure for measurements performed below 30 MHz, when performing measurements at a closer distance than specified, the results shall be extrapolated to the specified distance by either making measurements at a minimum of two distances on at least one radial to determine the proper extrapolation factor or by using the square of an inverse linear distance extrapolation factor (40 dB/decade).

Note 2: At frequencies at or above 30 MHz, measurements may be performed at a distance other than what is specified provided: measurements are not made in the near field except where it can be shown that near field measurements are appropriate due to the characteristics of the device; and it can be demonstrated that the signal levels needed to be measured at the distance employed can be detected by the measurement equipment. Measurements shall not be performed at a distance greater than 30 meters unless it can be further demonstrated that measurements at a distance of 30 meters or less are impractical. When performing measurements at a distance other than that specified, the results shall be extrapolated to the specified distance using an extrapolation factor of 20 dB/decade (inverse linear-distance for field strength measurements; inverse-linear-distance-squared for power density measurements).

4.4. Test Procedure

Test Method			
	References Rule	Chapter	Description
<input type="checkbox"/>	ANSI C63.10	11.11	Emissions in non-restricted frequency bands
	<input type="checkbox"/> ANSI C63.10	11.11.2	Reference level measurement
	<input type="checkbox"/> ANSI C63.10	11.11.3	Emission level measurement
<input checked="" type="checkbox"/>	ANSI C63.10	11.12	Emissions in restricted frequency bands
	<input checked="" type="checkbox"/> ANSI C63.10	11.12.1	Radiated emission measurements
	<input checked="" type="checkbox"/> ANSI C63.10	11.12.2.7	Radiated spurious emission test
	<input checked="" type="checkbox"/> ANSI C63.10	6.4	Radiated emissions from unlicensed wireless devices below 30 MHz
	<input checked="" type="checkbox"/> ANSI C63.10	6.5	Radiated emissions from unlicensed wireless devices in the frequency range of 30 MHz to 1000 MHz
	<input checked="" type="checkbox"/> ANSI C63.10	6.6	Radiated emissions from unlicensed wireless devices above 1 GHz
	<input type="checkbox"/> ANSI C63.10	11.12.2.3	Quasi-peak measurement procedure
	<input type="checkbox"/> ANSI C63.10	11.12.2.4	Peak power measurement procedure
	<input type="checkbox"/> ANSI C63.10	11.12.2.5	Average power measurement procedures
	<input type="checkbox"/> ANSI C63.10	11.12.2.5.1	Trace averaging with continuous EUT transmission at full power
	<input type="checkbox"/> ANSI C63.10	11.12.2.5.2	Trace averaging across ON and OFF times of the EUT transmissions followed by duty cycle correction
	<input type="checkbox"/> ANSI C63.10	11.12.2.5.3	Reduced VBW averaging across ON and OFF times of the EUT transmissions with max hold

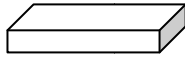
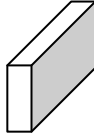
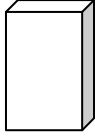
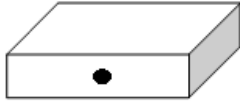
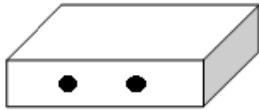
4.5. EUT test Axis definition

Item	Emissions in restricted frequency bands			
Device Category	<input type="checkbox"/>	Fixed point-to-point		
	<input type="checkbox"/>	Emit multiple directional beams, simultaneously or sequentially		
	<input checked="" type="checkbox"/>	Other cases		
Test mode	Mode 1			
Test method	<input checked="" type="checkbox"/>	Radiated		
		X Axis	Y Axis	Z Axis
				
		Worst Axis <input checked="" type="checkbox"/>	Worst Axis <input type="checkbox"/>	Worst Axis <input type="checkbox"/>
	<input type="checkbox"/>	Conducted		
	<input type="checkbox"/>	Chain 0		
				
	<input type="checkbox"/>	Chain 0	Chain 1	
				
	<input type="checkbox"/>	Chain 0	Chain 1	Chain 2
				

4.6. Test Result

Muruta:

Engineer: YULIU	
Site: AC5	Time: 2019/04/10 - 21:33
Limit: FCC_Part15.209_RE(3m)	Margin: 0
Probe: Horn_3117_00167055(1-18GHz)	Polarity: Vertical
EUT: LED LAMP	Power: AC 120V/60Hz
Note: Mode1:Transmit at 2405Mhz by Zigbee	

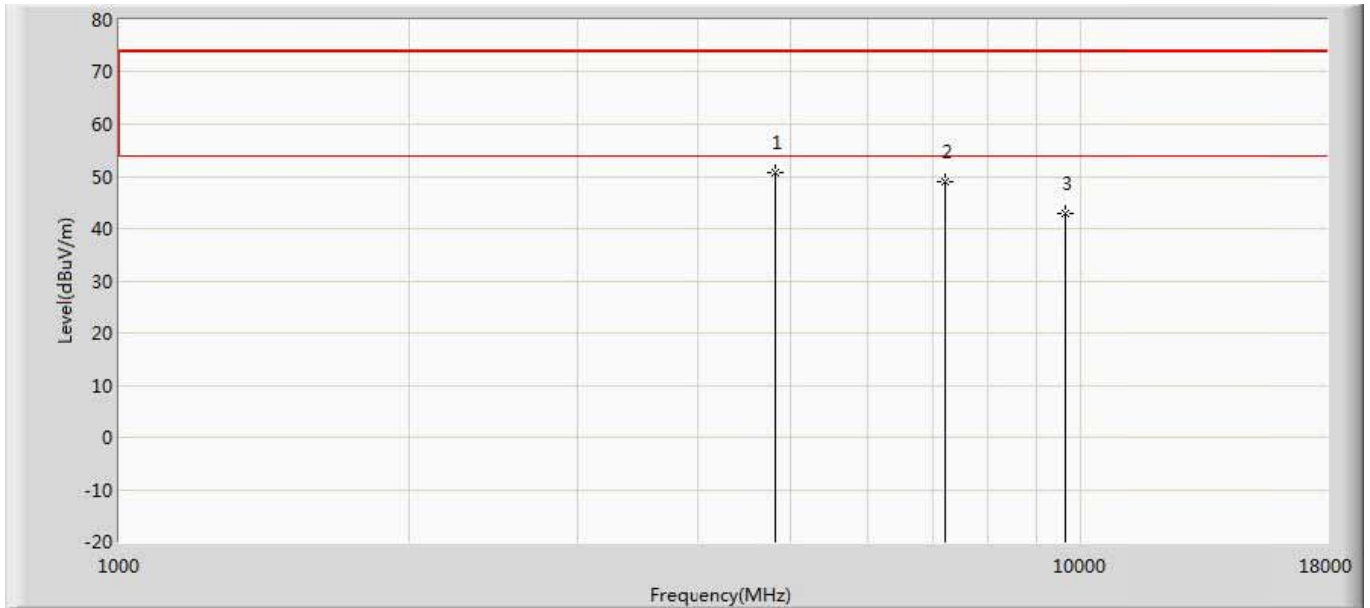

No	Mark	Frequency (MHz)	Measure Level (dBuV/m)	Reading Level (dBuV)	Over Limit (dB)	Limit (dBuV/m)	Factor (dB)	Type
1	*	4808.000	50.774	52.575	-23.226	74.000	-1.801	PK
2		7213.500	49.048	47.256	-24.952	74.000	1.792	PK
3		9620.000	42.982	38.874	-31.018	74.000	4.108	PK

Engineer: YULIU	
Site: AC5	Time: 2019/04/10 - 21:33
Limit: FCC_Part15.209_RE(3m)	Margin: 0
Probe: Horn_3117_00167055(1-18GHz)	Polarity: Horizontal
EUT: LED LAMP	Power: AC 120V/60Hz
Note: Mode1:Transmit at 2405Mhz by Zigbee	

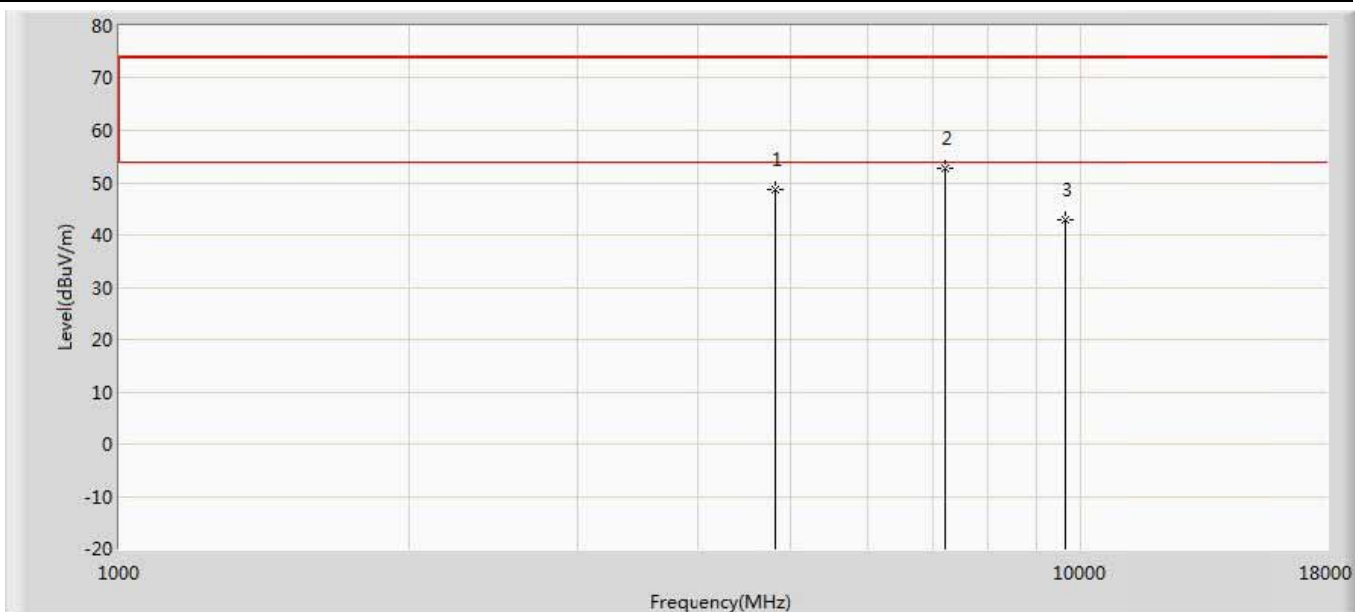

No	Mark	Frequency (MHz)	Measure Level (dBuV/m)	Reading Level (dBuV)	Over Limit (dB)	Limit (dBuV/m)	Factor (dB)	Type
1		4808.000	48.763	50.564	-25.237	74.000	-1.801	PK
2	*	7213.500	52.827	51.035	-21.173	74.000	1.792	PK
3		9620.000	42.893	38.785	-31.107	74.000	4.108	PK

Engineer: YULIU	
Site: AC5	Time: 2019/04/10 - 21:33
Limit: FCC_Part15.209_RE(3m)	Margin: 0
Probe: Horn_3117_00167055(1-18GHz)	Polarity: Vertical
EUT: LED LAMP	Power: AC 120V/60Hz
Note: Mode1:Transmit at 2440Mhz by Zigbee	

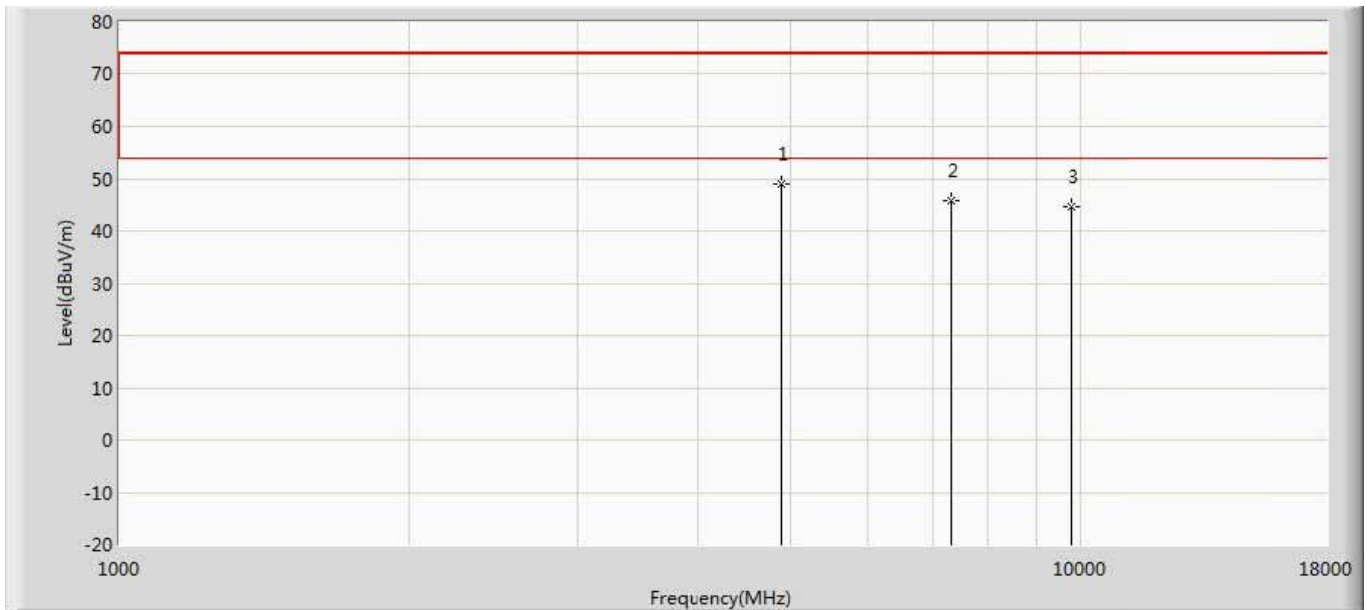

No	Mark	Frequency (MHz)	Measure Level (dBuV/m)	Reading Level (dBuV)	Over Limit (dB)	Limit (dBuV/m)	Factor (dB)	Type
1	*	4876.000	49.112	50.331	-24.888	74.000	-1.219	PK
2		7320.000	45.914	44.031	-28.086	74.000	1.884	PK
3		9760.000	44.678	38.866	-29.322	74.000	5.812	PK

Engineer: YULIU	
Site: AC5	Time: 2019/04/10 - 21:33
Limit: FCC_Part15.209_RE(3m)	Margin: 0
Probe: Horn_3117_00167055(1-18GHz)	Polarity: Horizontal
EUT: LED LAMP	Power: AC 120V/60Hz
Note: Mode1:Transmit at 2440Mhz by Zigbee	

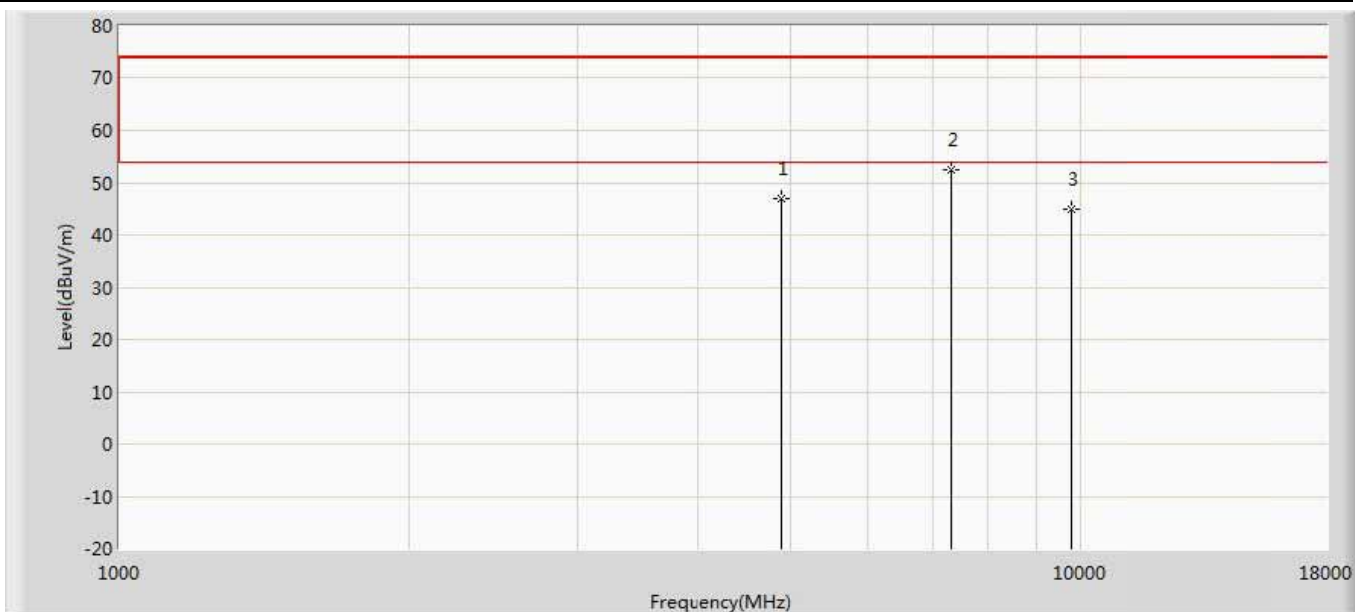

No	Mark	Frequency (MHz)	Measure Level (dBuV/m)	Reading Level (dBuV)	Over Limit (dB)	Limit (dBuV/m)	Factor (dB)	Type
1		4884.500	46.987	48.345	-27.013	74.000	-1.358	PK
2	*	7315.500	52.322	50.477	-21.678	74.000	1.845	PK
3		9760.000	44.839	39.027	-29.161	74.000	5.812	PK

Engineer: YULIU	
Site: AC5	Time: 2019/04/10 - 21:33
Limit: FCC_Part15.209_RE(3m)	Margin: 0
Probe: Horn_3117_00167055(1-18GHz)	Polarity: Vertical
EUT: LED LAMP	Power: AC 120V/60Hz
Note: Mode1:Transmit at 2480Mhz by Zigbee	

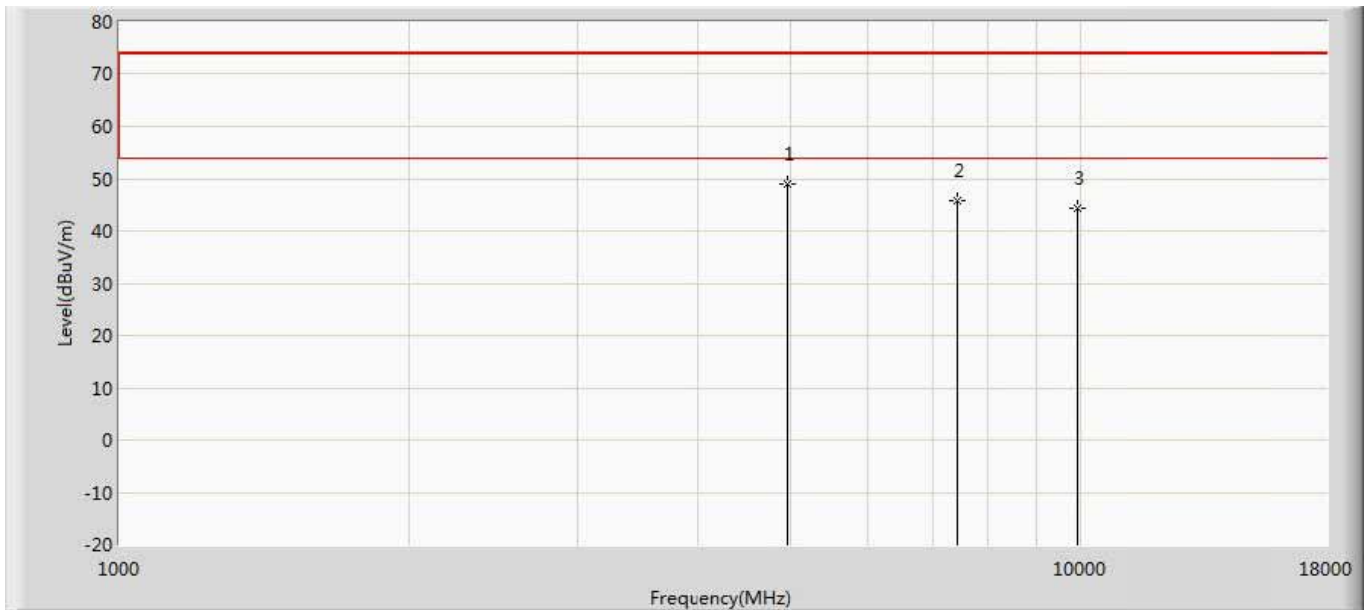

No	Mark	Frequency (MHz)	Measure Level (dBuV/m)	Reading Level (dBuV)	Over Limit (dB)	Limit (dBuV/m)	Factor (dB)	Type
1	*	4961.000	48.972	50.128	-25.028	74.000	-1.156	PK
2		7440.000	45.725	43.299	-28.275	74.000	2.426	PK
3		9920.000	44.393	39.139	-29.607	74.000	5.253	PK

Engineer: YULIU	
Site: AC5	Time: 2019/04/10 - 21:34
Limit: FCC_Part15.209_RE(3m)	Margin: 0
Probe: Horn_3117_00167055(1-18GHz)	Polarity: Horizontal
EUT: LED LAMP	Power: AC 120V/60Hz
Note: Mode1:Transmit at 2480Mhz by Zigbee	

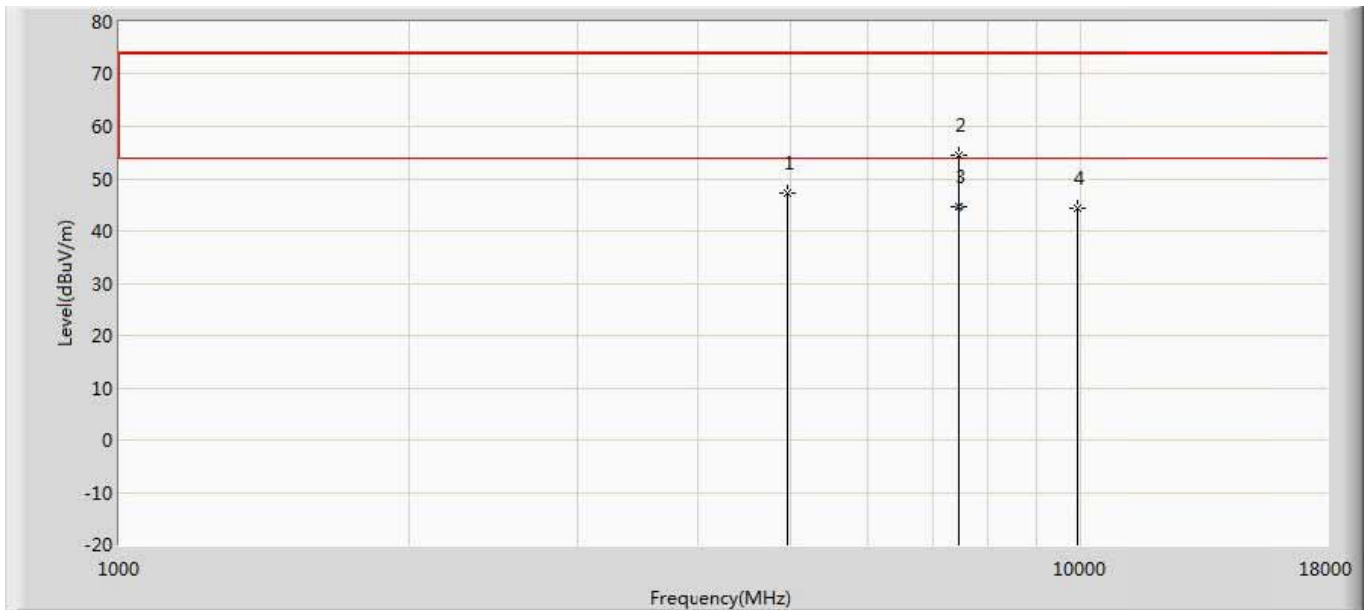

No	Mark	Frequency (MHz)	Measure Level (dBuV/m)	Reading Level (dBuV)	Over Limit (dB)	Limit (dBuV/m)	Factor (dB)	Type
1		4961.000	47.349	48.505	-26.651	74.000	-1.156	PK
2		7443.000	54.544	52.055	-19.456	74.000	2.489	PK
3	*	7443.000	44.496	42.007	-9.504	54.000	2.489	AV
4		9920.000	44.389	39.135	-29.611	74.000	5.253	PK

Diodes:

Engineer: YULIU	
Site: AC5	Time: 2019/04/10 - 21:43
Limit: FCC_Part15.209_RE(3m)	Margin: 0
Probe: Horn_3117_00167055(1-18GHz)	Polarity: Vertical
EUT: LED LAMP	Power: AC 120V/60Hz
Note: Mode1:Transmit at 2402Mhz by Zigbee	

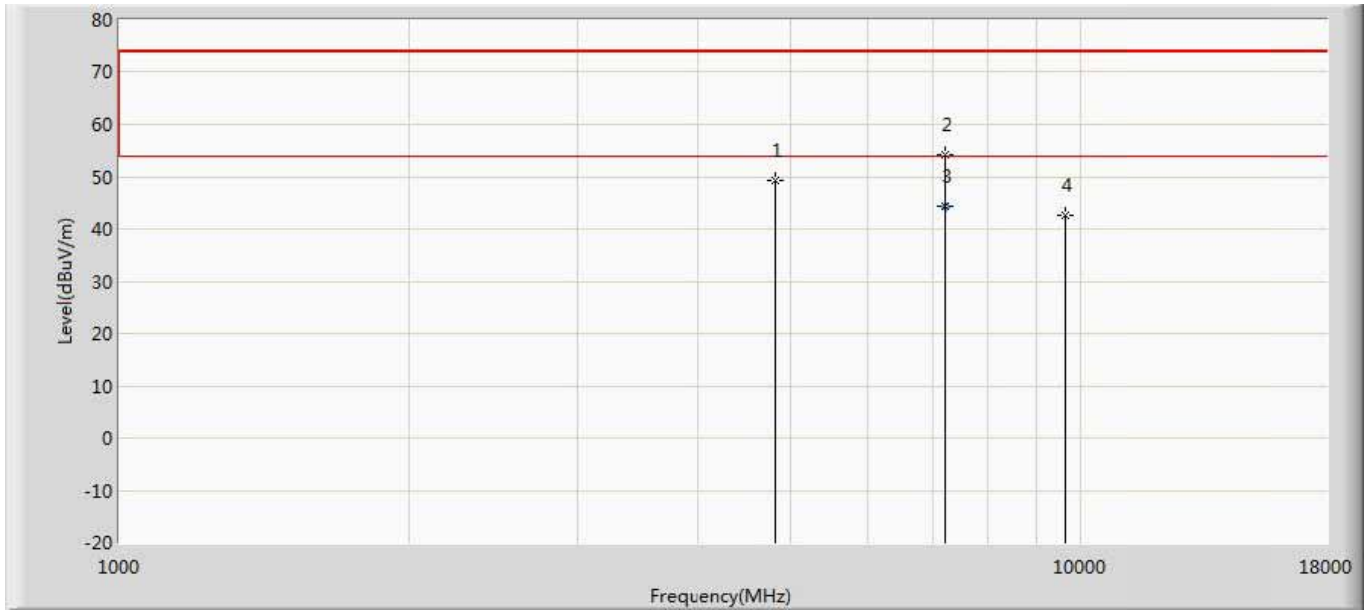

No	Mark	Frequency (MHz)	Measure Level (dBuV/m)	Reading Level (dBuV)	Over Limit (dB)	Limit (dBuV/m)	Factor (dB)	Type
1		4808.000	49.392	51.193	-24.608	74.000	-1.801	PK
2		7213.500	54.082	52.290	-19.918	74.000	1.792	PK
3	*	7213.500	44.332	42.540	-9.668	54.000	1.792	AV
4		9620.000	42.682	38.574	-31.318	74.000	4.108	PK

Engineer: YULIU	
Site: AC5	Time: 2019/04/10 - 21:43
Limit: FCC_Part15.209_RE(3m)	Margin: 0
Probe: Horn_3117_00167055(1-18GHz)	Polarity: Horizontal
EUT: LED LAMP	Power: AC 120V/60Hz
Note: Mode1:Transmit at 2402Mhz by Zigbee	

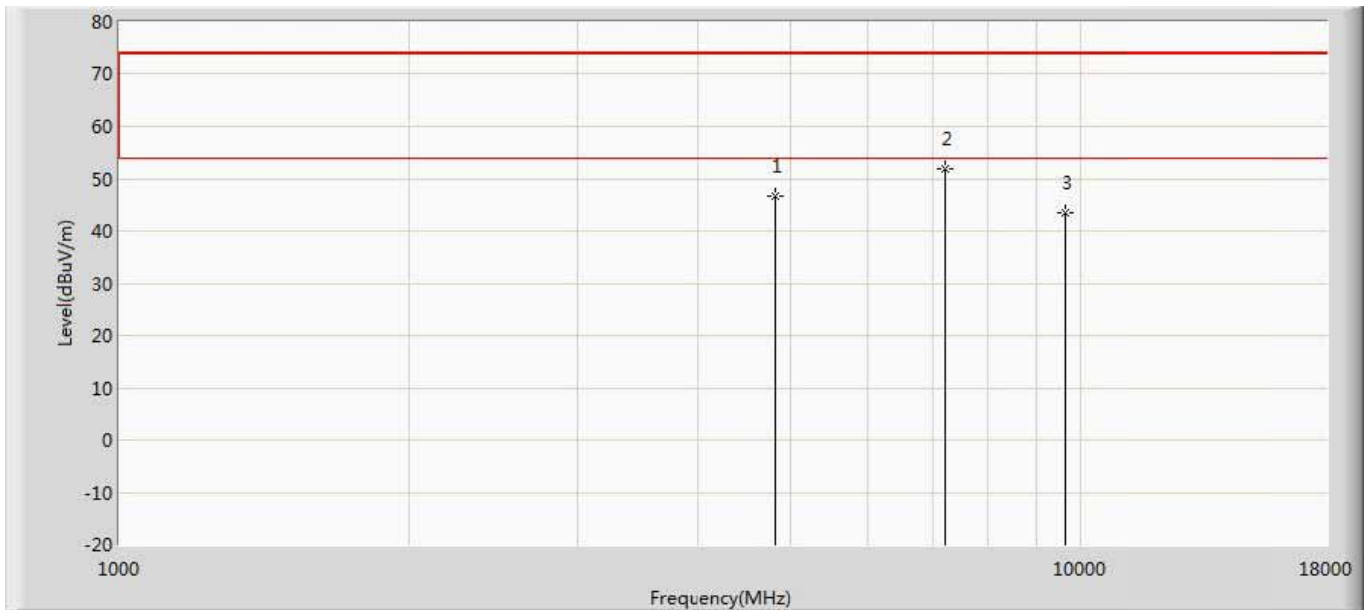

No	Mark	Frequency (MHz)	Measure Level (dBuV/m)	Reading Level (dBuV)	Over Limit (dB)	Limit (dBuV/m)	Factor (dB)	Type
1		4808.000	46.589	48.390	-27.411	74.000	-1.801	PK
2	*	7213.500	51.757	49.965	-22.243	74.000	1.792	PK
3		9620.000	43.491	39.383	-30.509	74.000	4.108	PK

Engineer: YULIU	
Site: AC5	Time: 2019/04/10 - 21:43
Limit: FCC_Part15.209_RE(3m)	Margin: 0
Probe: Horn_3117_00167055(1-18GHz)	Polarity: Vertical
EUT: LED LAMP	Power: AC 120V/60Hz
Note: Mode1:Transmit at 2440Mhz by Zigbee	

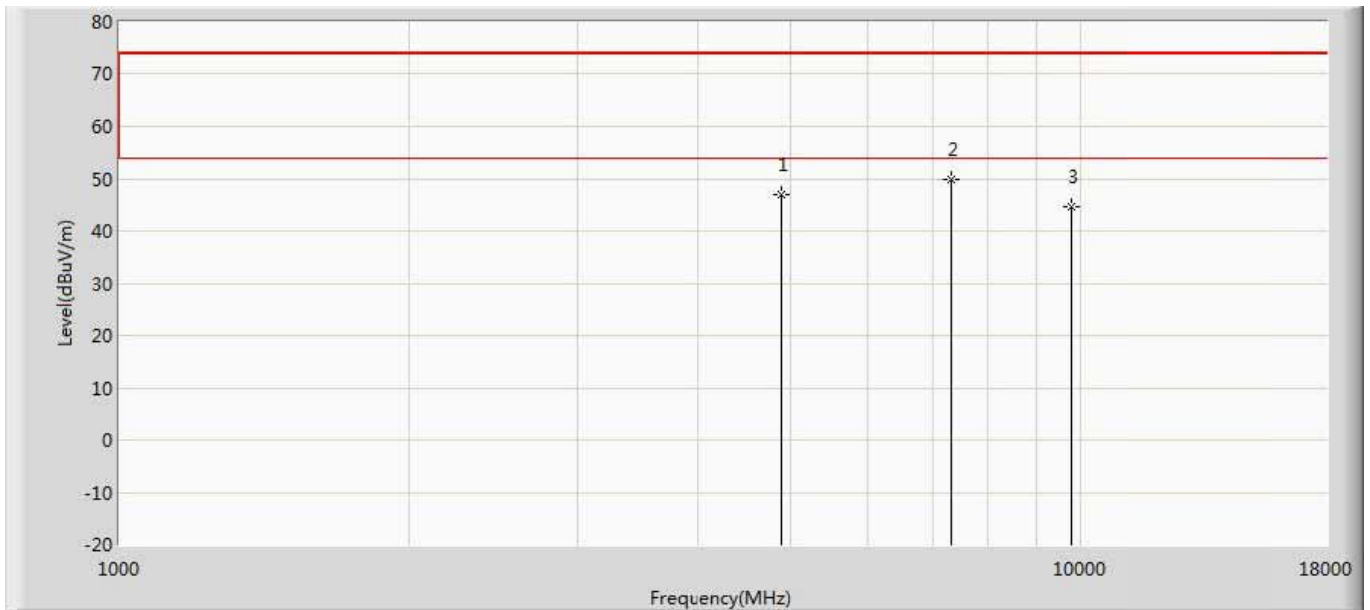

No	Mark	Frequency (MHz)	Measure Level (dBuV/m)	Reading Level (dBuV)	Over Limit (dB)	Limit (dBuV/m)	Factor (dB)	Type
1		4884.500	46.859	48.217	-27.141	74.000	-1.358	PK
2	*	7315.500	49.938	48.093	-24.062	74.000	1.845	PK
3		9760.000	44.522	38.710	-29.478	74.000	5.812	PK

Engineer: YULIU	
Site: AC5	Time: 2019/04/10 - 21:43
Limit: FCC_Part15.209_RE(3m)	Margin: 0
Probe: Horn_3117_00167055(1-18GHz)	Polarity: Horizontal
EUT: LED LAMP	Power: AC 120V/60Hz
Note: Mode1:Transmit at 2440Mhz by Zigbee	

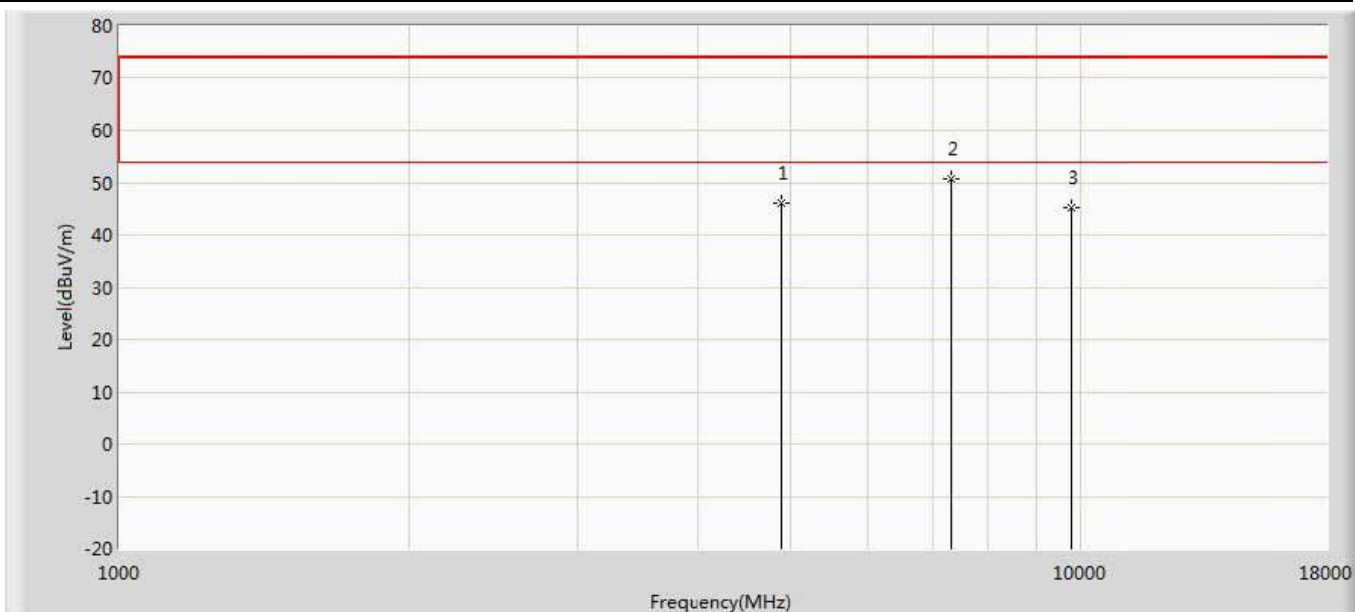

No	Mark	Frequency (MHz)	Measure Level (dBuV/m)	Reading Level (dBuV)	Over Limit (dB)	Limit (dBuV/m)	Factor (dB)	Type
1		4884.500	46.022	47.380	-27.978	74.000	-1.358	PK
2	*	7315.500	50.816	48.971	-23.184	74.000	1.845	PK
3		9760.000	45.207	39.395	-28.793	74.000	5.812	PK

Engineer: YULIU	
Site: AC5	Time: 2019/04/10 - 21:43
Limit: FCC_Part15.209_RE(3m)	Margin: 0
Probe: Horn_3117_00167055(1-18GHz)	Polarity: Vertical
EUT: LED LAMP	Power: AC 120V/60Hz
Note: Mode1:Transmit at 2480Mhz by Zigbee	

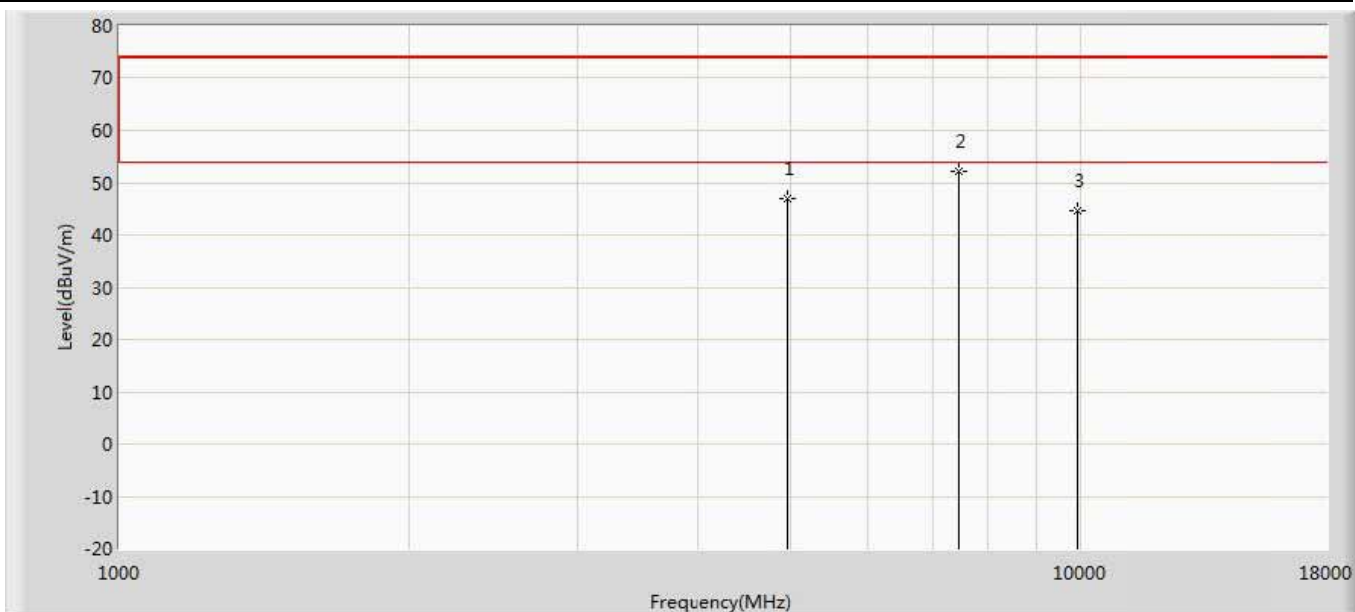

No	Mark	Frequency (MHz)	Measure Level (dBuV/m)	Reading Level (dBuV)	Over Limit (dB)	Limit (dBuV/m)	Factor (dB)	Type
1		4961.000	46.856	48.012	-27.144	74.000	-1.156	PK
2	*	7443.000	52.246	49.757	-21.754	74.000	2.489	PK
3		9920.000	44.666	39.412	-29.334	74.000	5.253	PK

Engineer: YULIU	
Site: AC5	Time: 2019/04/10 - 21:43
Limit: FCC_Part15.209_RE(3m)	Margin: 0
Probe: Horn_3117_00167055(1-18GHz)	Polarity: Horizontal
EUT: LED LAMP	Power: AC 120V/60Hz
Note: Mode1:Transmit at 2480Mhz by Zigbee	

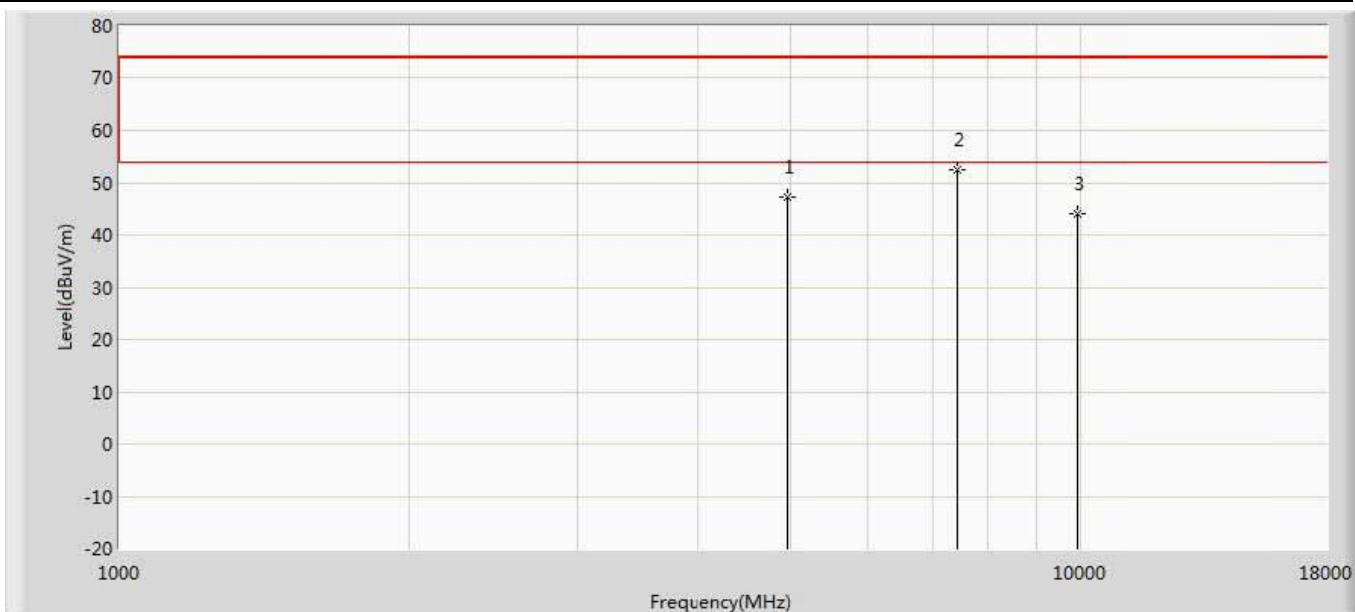

No	Mark	Frequency (MHz)	Measure Level (dBuV/m)	Reading Level (dBuV)	Over Limit (dB)	Limit (dBuV/m)	Factor (dB)	Type
1		4961.000	47.277	48.433	-26.723	74.000	-1.156	PK
2	*	7434.500	52.377	50.069	-21.623	74.000	2.308	PK
3		9920.000	44.024	38.770	-29.976	74.000	5.253	PK

Kdx:

Engineer: YULIU	
Site: AC5	Time: 2019/04/15 - 09:47
Limit: FCC_Part15.209_RE(3m)	Margin: 0
Probe: Horn_3117_00167055(1-18GHz)	Polarity: Vertical
EUT:LED LAMP	Power: AC 120V/60Hz
Note: Mode1:Transmit at 2405Mhz by Zigbee	

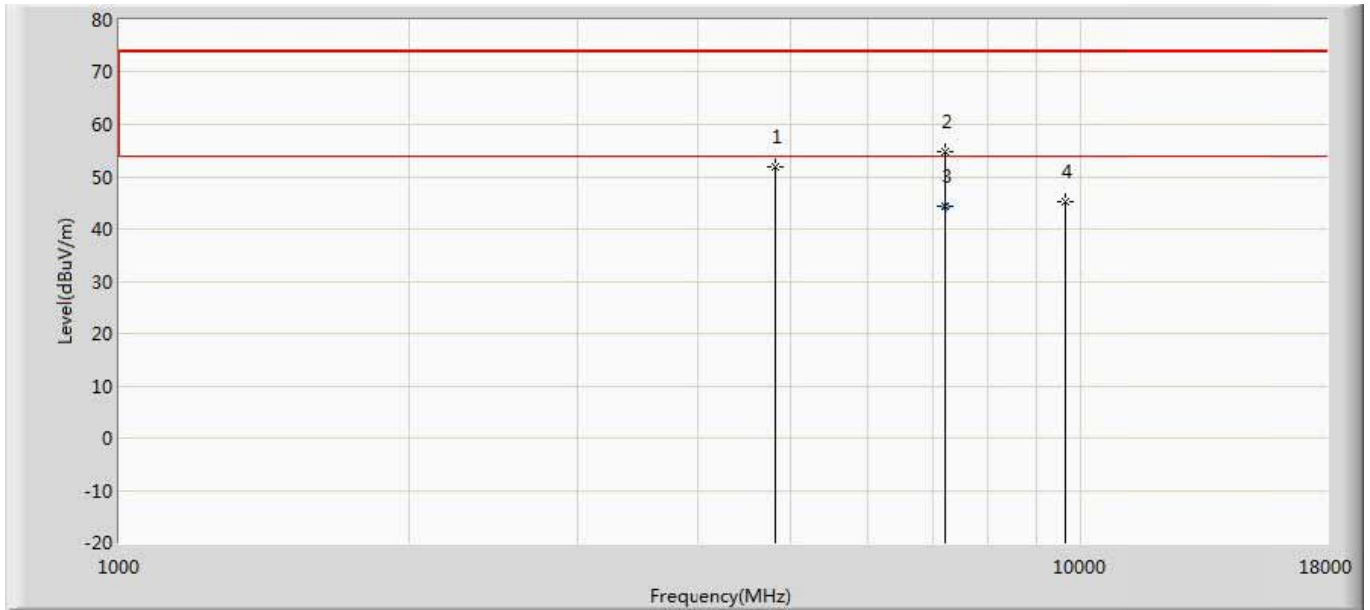

No	Mark	Frequency (MHz)	Measure Level (dBuV/m)	Reading Level (dBuV)	Over Limit (dB)	Limit (dBuV/m)	Factor (dB)	Type
1		4808.000	51.902	50.193	-22.098	74.000	1.709	PK
2		7213.500	54.858	49.585	-19.142	74.000	5.273	PK
3	*	7216.100	44.291	39.012	-9.709	54.000	5.280	AV
4		9620.000	45.323	38.656	-28.677	74.000	6.667	PK

Engineer: YULIU	
Site: AC5	Time: 2019/04/15 - 09:47
Limit: FCC_Part15.209_RE(3m)	Margin: 0
Probe: Horn_3117_00167055(1-18GHz)	Polarity: Horizontal
EUT:LED LAMP	Power: AC 120V/60Hz
Note: Mode1:Transmit at 2405Mhz by Zigbee	

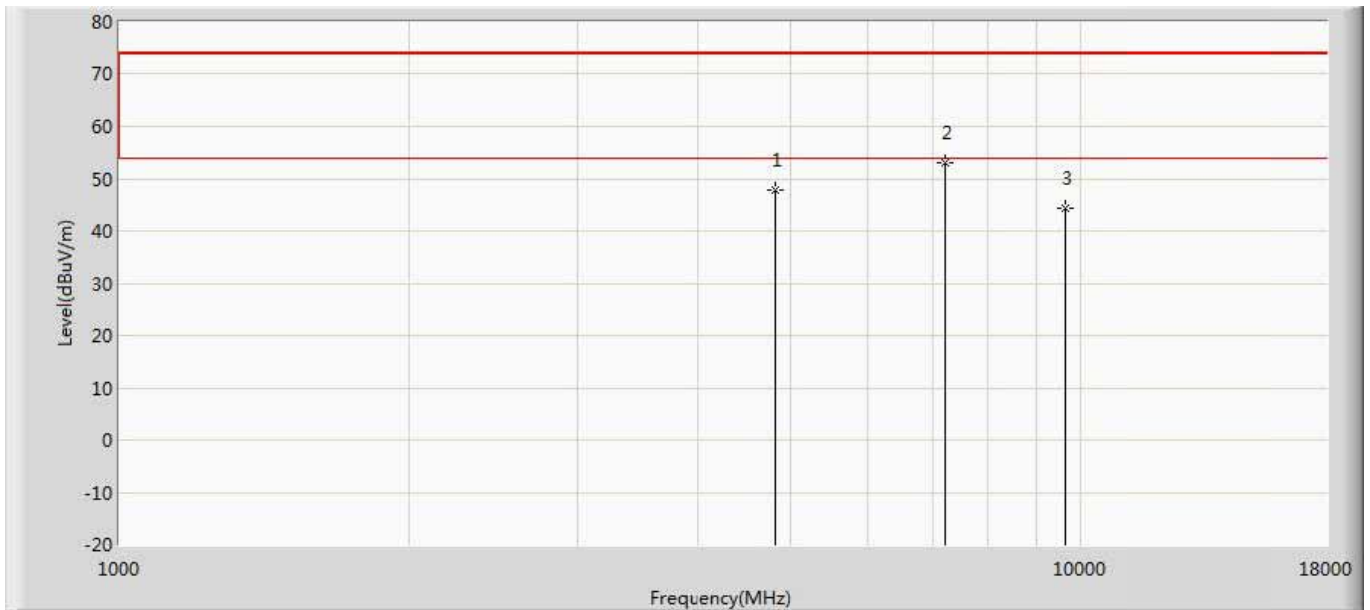

No	Mark	Frequency (MHz)	Measure Level (dBuV/m)	Reading Level (dBuV)	Over Limit (dB)	Limit (dBuV/m)	Factor (dB)	Type
1		4808.000	47.936	46.227	-26.064	74.000	1.709	PK
2	*	7213.500	53.030	47.757	-20.970	74.000	5.273	PK
3		9620.000	44.395	37.728	-29.605	74.000	6.667	PK

Engineer: YULIU	
Site: AC5	Time: 2019/04/15 - 09:47
Limit: FCC_Part15.209_RE(3m)	Margin: 0
Probe: Horn_3117_00167055(1-18GHz)	Polarity: Vertical
EUT:LED LAMP	Power: AC 120V/60Hz
Note: Mode1:Transmit at 2440Mhz by Zigbee	

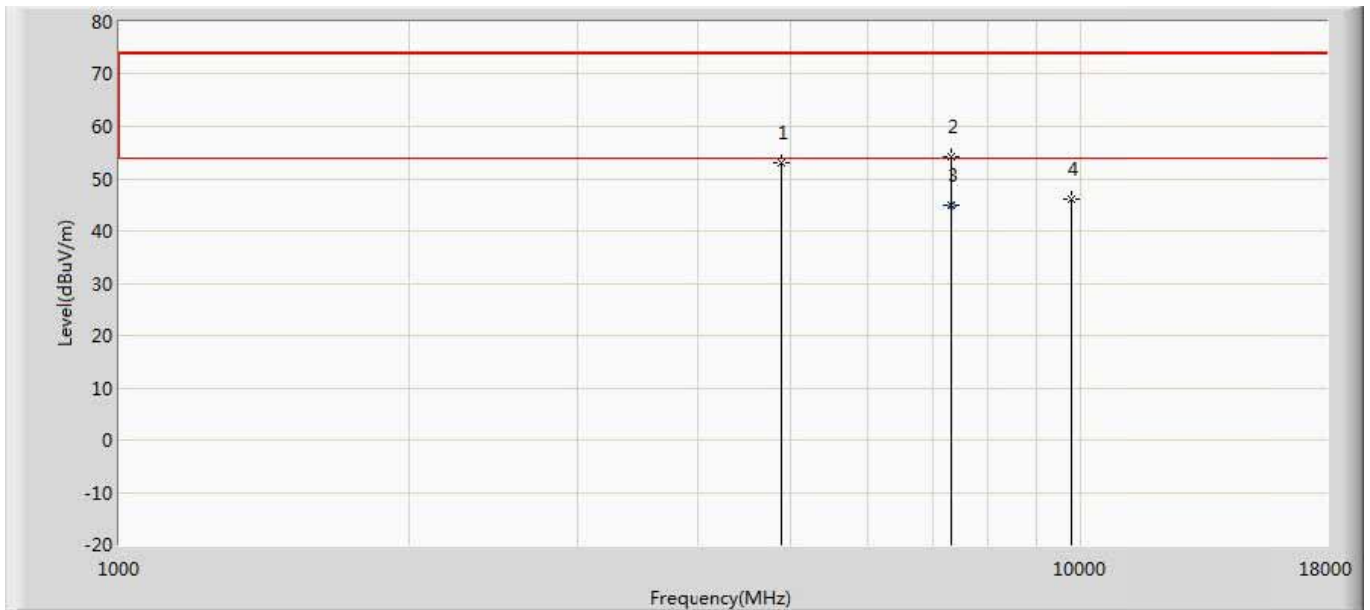

No	Mark	Frequency (MHz)	Measure Level (dBuV/m)	Reading Level (dBuV)	Over Limit (dB)	Limit (dBuV/m)	Factor (dB)	Type
1		4884.500	53.152	51.323	-20.848	74.000	1.829	PK
2		7324.000	54.152	48.557	-19.848	74.000	5.595	PK
3	*	7324.000	45.037	39.442	-8.963	54.000	5.595	AV
4		9760.000	46.157	39.038	-27.843	74.000	7.120	PK

Engineer: YULIU	
Site: AC5	Time: 2019/04/15 - 09:47
Limit: FCC_Part15.209_RE(3m)	Margin: 0
Probe: Horn_3117_00167055(1-18GHz)	Polarity: Horizontal
EUT:LED LAMP	Power: AC 120V/60Hz
Note: Mode1:Transmit at 2440Mhz by Zigbee	

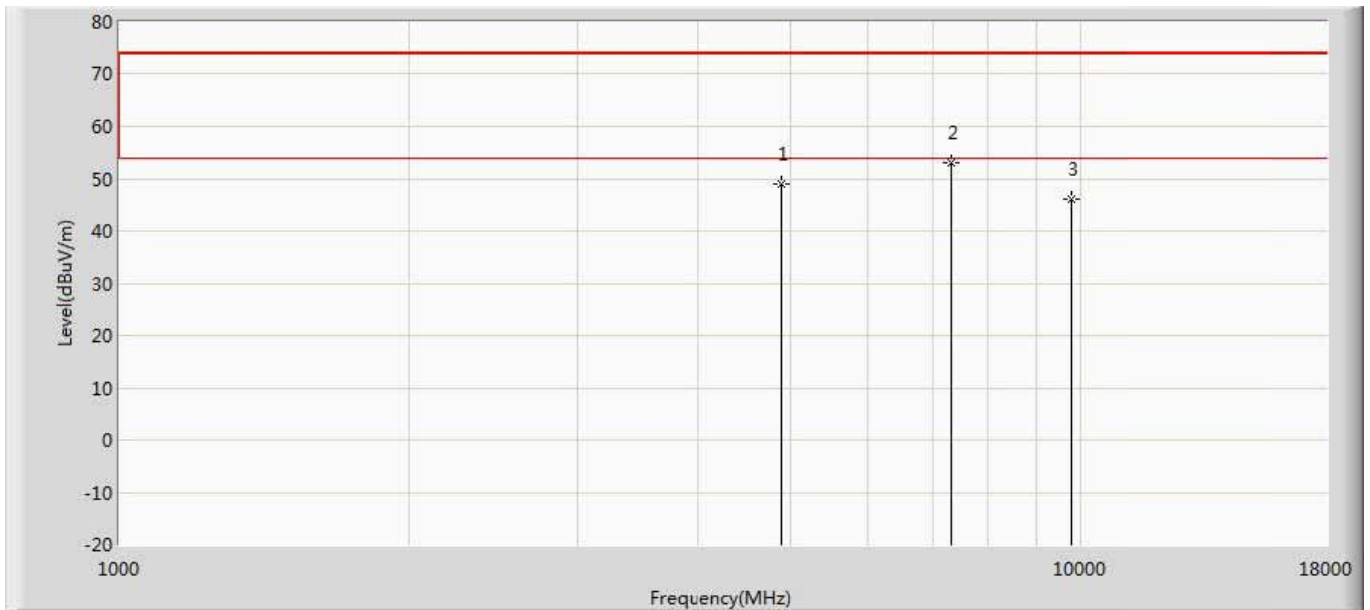

No	Mark	Frequency (MHz)	Measure Level (dBuV/m)	Reading Level (dBuV)	Over Limit (dB)	Limit (dBuV/m)	Factor (dB)	Type
1		4884.500	49.042	47.213	-24.958	74.000	1.829	PK
2	*	7324.000	53.073	47.478	-20.927	74.000	5.595	PK
3		9760.000	46.068	38.949	-27.932	74.000	7.120	PK

Engineer: YULIU	
Site: AC5	Time: 2019/04/15 - 09:47
Limit: FCC_Part15.209_RE(3m)	Margin: 0
Probe: Horn_3117_00167055(1-18GHz)	Polarity: Vertical
EUT:LED LAMP	Power: AC 120V/60Hz
Note: Mode1:Transmit at 2480Mhz by Zigbee	

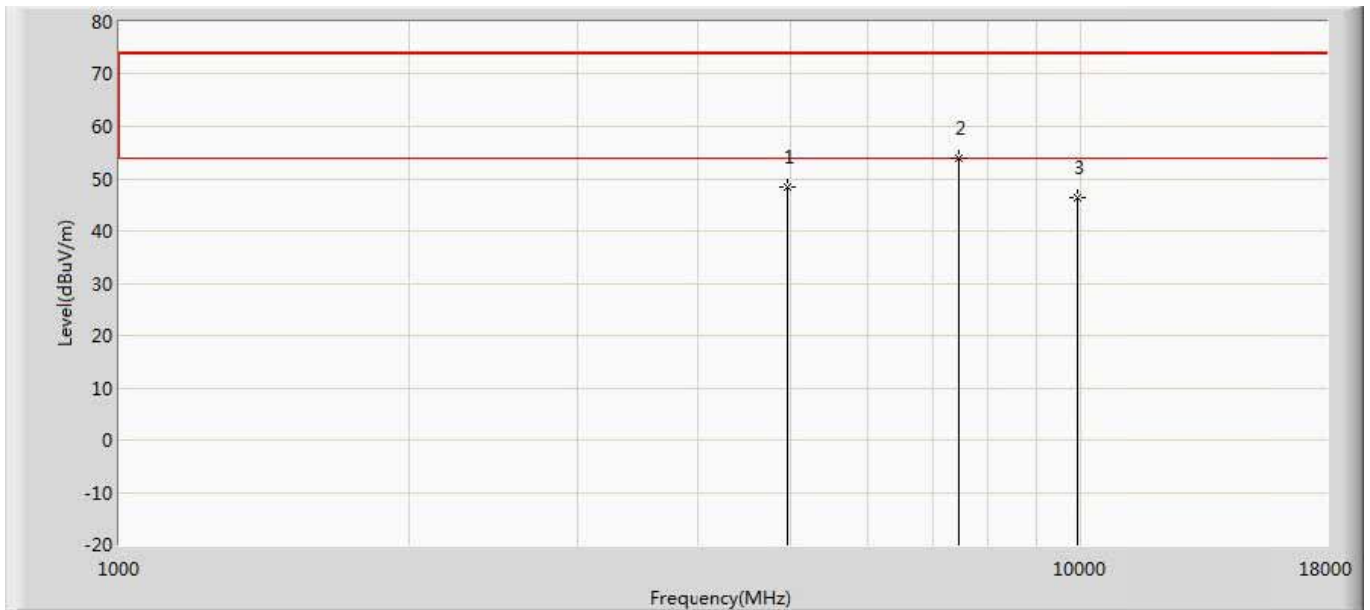

No	Mark	Frequency (MHz)	Measure Level (dBuV/m)	Reading Level (dBuV)	Over Limit (dB)	Limit (dBuV/m)	Factor (dB)	Type
1		4961.000	48.389	46.400	-25.611	74.000	1.989	PK
2	*	7443.000	53.780	48.450	-20.220	74.000	5.330	PK
3		9920.000	46.446	39.357	-27.554	74.000	7.088	PK

Engineer: YULIU	
Site: AC5	Time: 2019/04/15 - 09:47
Limit: FCC_Part15.209_RE(3m)	Margin: 0
Probe: Horn_3117_00167055(1-18GHz)	Polarity: Horizontal
EUT:LED LAMP	Power: AC 120V/60Hz
Note: Mode1:Transmit at 2480Mhz by Zigbee	

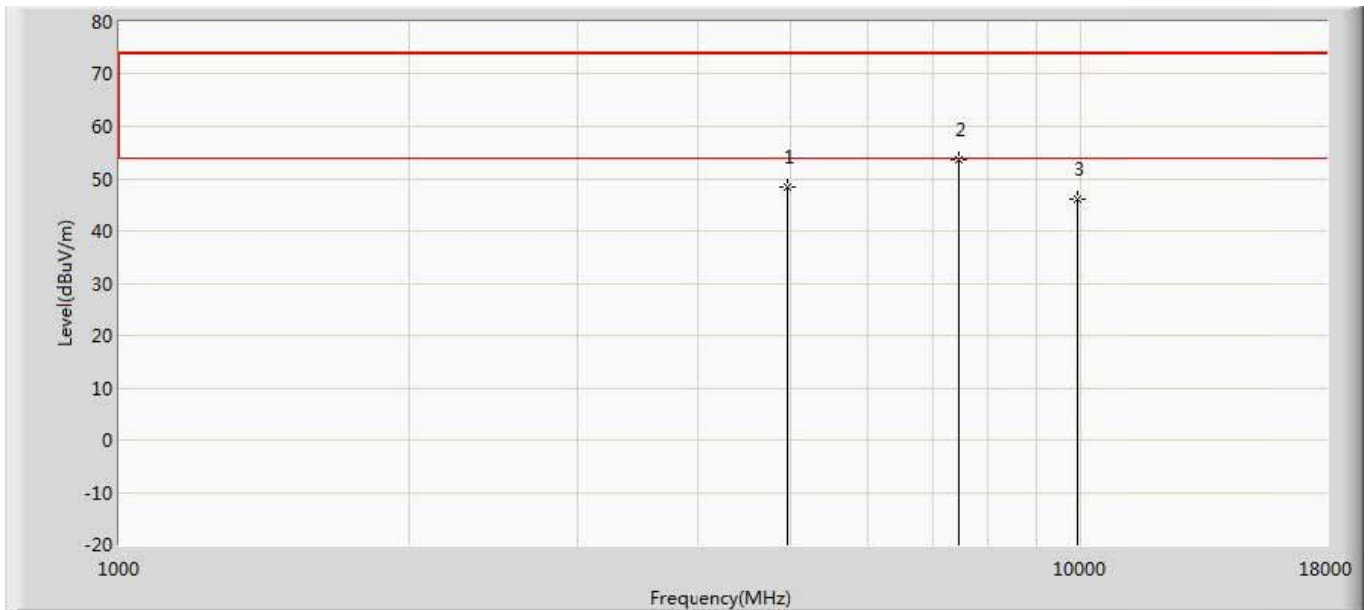

No	Mark	Frequency (MHz)	Measure Level (dBuV/m)	Reading Level (dBuV)	Over Limit (dB)	Limit (dBuV/m)	Factor (dB)	Type
1		4961.000	48.509	46.520	-25.491	74.000	1.989	PK
2	*	7443.000	53.587	48.257	-20.413	74.000	5.330	PK
3		9920.000	46.173	39.084	-27.827	74.000	7.088	PK

Note: 1. Measure Level = Reading Level + Factor.

Note: 2. The test frequency range, 9kHz~30MHz, 18GHz~25GHz, both of the worst case are at least 20dB below the limits, therefore no data appear in the report.

Note: 3. This limit applies for using average detector, if the test result on peak is lower than average limit, then average measurement needn't be performed.

Note: 4. The RBW set up, see Clause 6.6.

The worst case of Radiated Emission below 1GHz:

Engineer: LiuYu	
Site: AC2	Time: 2019/04/03 - 15:23
Limit: FCC_Part15.109_RE(3m)_ClassB	Margin: 0
Probe: AC2_3M(30-1000M)	Polarity: Horizontal
EUT: LED LAMP	Power: AC 120V/60Hz
Note: Mode 1	

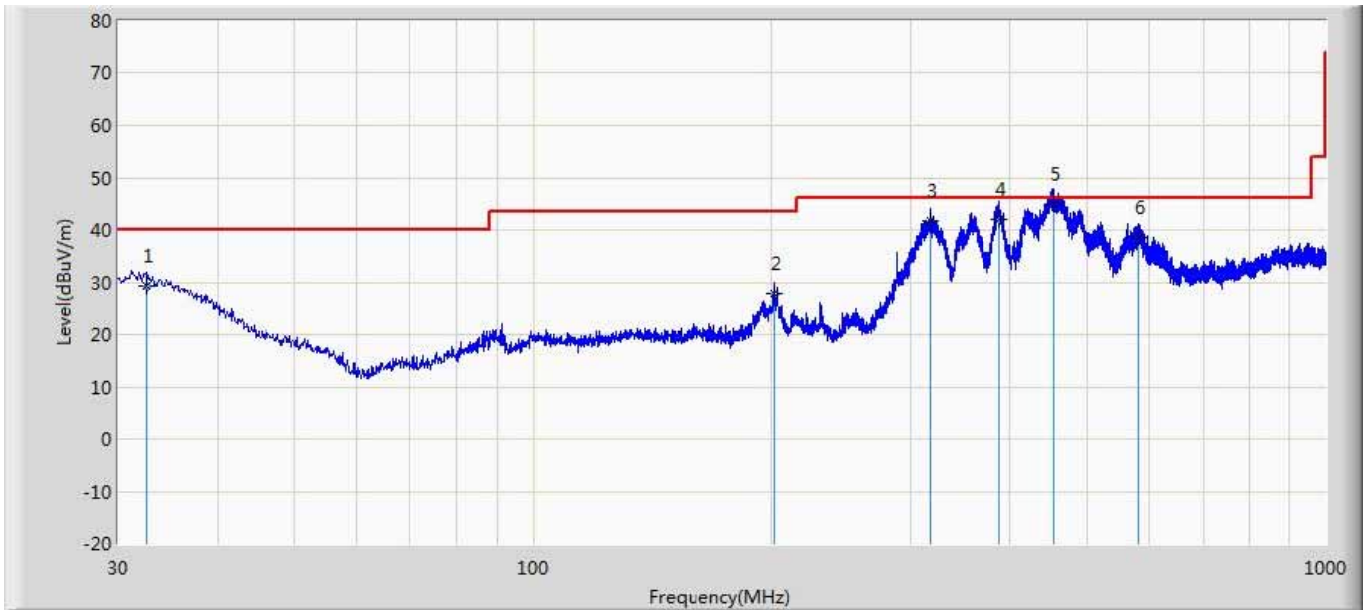

No	Mark	Frequency (MHz)	Measure Level (dBuV/m)	Reading Level (dBuV)	Over Limit (dB)	Limit (dBuV/m)	Factor (dB)	Ant Pos (cm)	Table Pos (deg)	Type
1		32.546	29.149	1.774	-10.851	40.000	27.375	125	48	QP
2		201.690	27.814	9.973	-15.686	43.500	17.841	108	128	QP
3		316.756	41.773	20.893	-4.227	46.000	20.880	188	264	QP
4		387.809	42.154	17.364	-3.846	46.000	24.790	183	115	QP
5	*	453.526	44.898	17.714	-1.102	46.000	27.184	190	228	QP
6		581.930	38.621	9.930	-7.379	46.000	28.691	174	355	QP

Note:

1. All Readings below 1GHz are Quasi-Peak, above are performed with peak and/or average measurements as necessary.
2. " * ", means this data is the worst emission level.
3. Measurement Level = Reading Level + Factor(Probe+Cable-Amp).

Engineer: LiuYu	
Site: AC2	Time: 2019/04/03 - 18:23
Limit: FCC_Part15.109_RE(3m)_ClassB	Margin: 0
Probe: AC2_3M(30-1000M)	Polarity: Vertical
EUT: LED LAMP	Power: AC 120V/60Hz
Note: Mode 1	

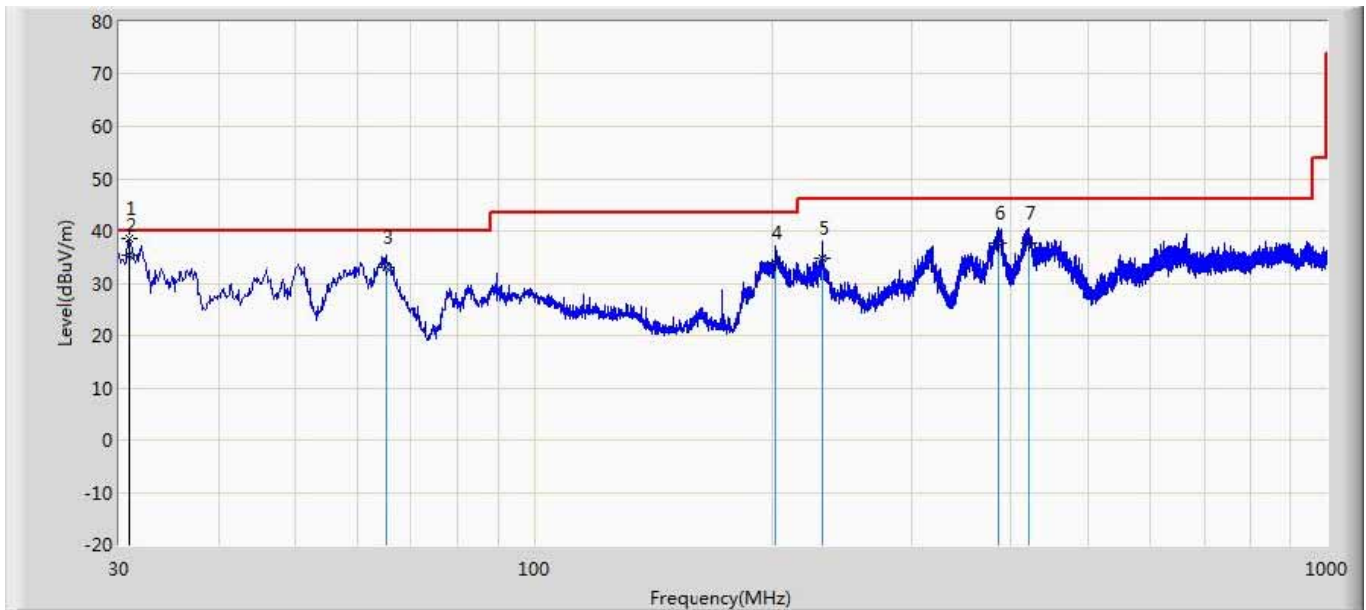

No	Mark	Frequency (MHz)	Measure Level (dBuV/m)	Reading Level (dBuV)	Over Limit (dB)	Limit (dBuV/m)	Factor (dB)	Ant Pos (cm)	Table Pos (deg)	Type
1	*	30.970	38.604	14.586	-1.396	40.000	24.018	0	0	PK
2		30.970	35.472	11.454	-4.528	40.000	24.018	145	360	QP
3		65.041	32.955	16.896	-7.045	40.000	16.060	132	267	QP
4		202.296	33.978	10.377	-9.522	43.500	23.600	188	39	QP
5		231.275	34.795	12.089	-11.205	46.000	22.706	138	246	QP
6		387.081	37.552	13.764	-8.448	46.000	23.788	169	245	QP
7		421.152	37.679	11.029	-8.321	46.000	26.650	166	294	QP

Note:

1. All Readings below 1GHz are Quasi-Peak, above are performed with peak and/or average measurements as necessary.
2. " * ", means this data is the worst emission level.
3. Measurement Level = Reading Level + Factor(Probe+Cable-Amp).

5. Emissions in non-restricted frequency bands

5.1. Test Equipment

Emissions in non-restricted frequency bands / TR-8					
Instrument	Manufacturer	Type No.	Serial No.	Cal. Date	Cal. Due Date
Spectrum Analyzer	Agilent	N9010A	MY48030494	2019.02.04	2020.02.03
EXA Spectrum Analyzer	Keysight	N9010A	MY55370495	2018.04.09	2019.04.08
MXA Signal Analyzer	Keysight	N9020A	MY56060147	2018.04.09	2019.04.08
Temperature/Humidity Meter	zhichen	ZC1-2	TR8-TH	2018.04.10	2019.04.09

Note: All equipments are calibrated with traceable calibrations. Each calibration is traceable to the national or international standards.

5.2. Test Setup

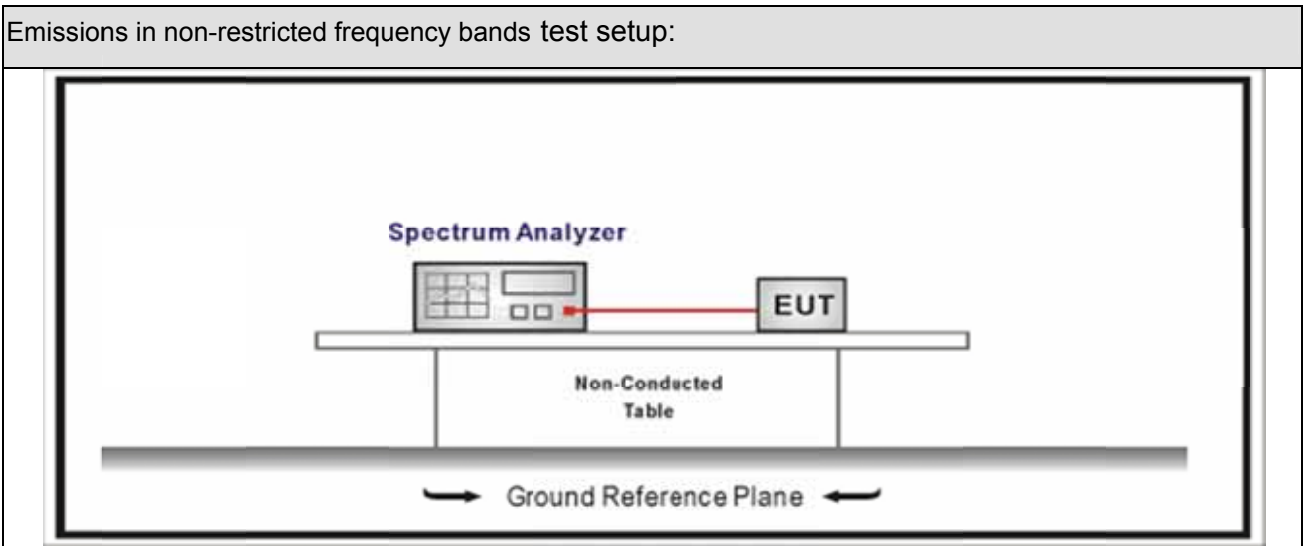



5.3. Limit

Un-Restricted Band Emissions Limit	
RF Output power (Detection methods)	Limit(dB)
RF Output power(Average detector)	30c(Note1)
RF Output power(PK detector)	20c(Note2)
<p>Note 1: If maximum conducted (average) output power was used to demonstrate compliance as described in 9.2, then the peak power in any 100 kHz bandwidth outside of the authorized frequency band shall be attenuated by at least 30 dB relative to the maximum in-band peak PSD level in 100 kHz (i.e., 30 dBc).</p> <p>Note 2: If the maximum peak conducted output power procedure was used, then the peak output power measured in any 100 kHz bandwidth outside of the authorized frequency band shall be attenuated by at least 20 dB relative to the maximum in-band peak PSD level in 100 kHz (i.e., 20 dBc).</p>	

5.4. Test Procedure

Test Method			
	References Rule	Chapter	Description
<input checked="" type="checkbox"/>	ANSI C63.10	11.11	Emissions in non-restricted frequency bands
	<input checked="" type="checkbox"/> ANSI C63.10	11.11.2	Reference level measurement
	<input checked="" type="checkbox"/> ANSI C63.10	11.11.3	Emission level measurement
<input type="checkbox"/>	ANSI C63.10	11.12	Emissions in restricted frequency bands
	<input type="checkbox"/> ANSI C63.10	11.12.1	Radiated emission measurements
	<input type="checkbox"/> ANSI C63.10	11.12.2.7	Radiated spurious emission test
<input type="checkbox"/>	ANSI C63.10	6.4	Radiated emissions from unlicensed wireless devices below 30 MHz
<input type="checkbox"/>	ANSI C63.10	6.5	Radiated emissions from unlicensed wireless devices in the frequency range of 30 MHz to 1000 MHz
<input type="checkbox"/>	ANSI C63.10	6.6	Radiated emissions from unlicensed wireless devices above 1 GHz
	<input type="checkbox"/> ANSI C63.10	11.12.2	Antenna-port conducted measurements
	<input type="checkbox"/> ANSI C63.10	11.12.2.3	Quasi-peak measurement procedure
	<input type="checkbox"/> ANSI C63.10	11.12.2.4	Peak power measurement procedure
	<input type="checkbox"/> ANSI C63.10	11.12.2.5	Average power measurement procedures
	<input type="checkbox"/> ANSI C63.10	11.12.2.5.1	Trace averaging with continuous EUT transmission at full power
	<input type="checkbox"/> ANSI C63.10	11.12.2.5.2	Trace averaging across ON and OFF times of the EUT transmissions followed by duty cycle correction
	<input type="checkbox"/> ANSI C63.10	11.12.2.5.3	Reduced VBW averaging across ON and OFF times of the EUT transmissions with max hold

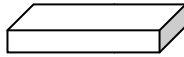
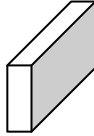
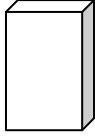
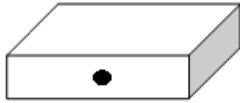
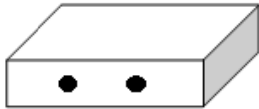
5.5. EUT test Axis definition

Item	Emissions in non-restricted frequency bands			
Device Category	<input type="checkbox"/>	Fixed point-to-point		
	<input type="checkbox"/>	Emit multiple directional beams, simultaneously or sequentially		
	<input checked="" type="checkbox"/>	Other cases		
Test mode	Mode 1			
Test method	<input type="checkbox"/>	Radiated		
		X Axis	Y Axis	Z Axis
				
		Worst Axis <input type="checkbox"/>	Worst Axis <input type="checkbox"/>	Worst Axis <input type="checkbox"/>
	<input checked="" type="checkbox"/>	Conducted		
	<input checked="" type="checkbox"/>	Chain 0		
				
	<input type="checkbox"/>	Chain 0	Chain 1	
				
		Worst Chain <input type="checkbox"/>	Worst Chain <input type="checkbox"/>	
	<input type="checkbox"/>	Chain 0	Chain 1	Chain 2
				
	Worst Chain <input type="checkbox"/>	Worst Chain <input type="checkbox"/>	Worst Chain <input type="checkbox"/>	

5.6. Test Result

Product Name	: LED lamp	Power	: AC 120V/60Hz
Test Mode	: Mode 1	Test Site	: TR-8
Test Date	: 2019.03.15		

Mode	Channel	Test Frequency (MHz)	In-Band PSD[a] (dBm/100kHz)	Frequency (MHz)	Out-Band PSD[b] (dBm/100kHz)	[a]-[b] (dB)	Limit (dB)	Result
1	11	2405	6.119	2400.00	-44.537	50.656	>20	Pass
1	26	2480	6.022	2500.00	-60.911	66.933	>20	Pass

Note: The worst case of Emissions in non-restricted frequency bands as below:

Mode 1 CH11 (2405MHz)

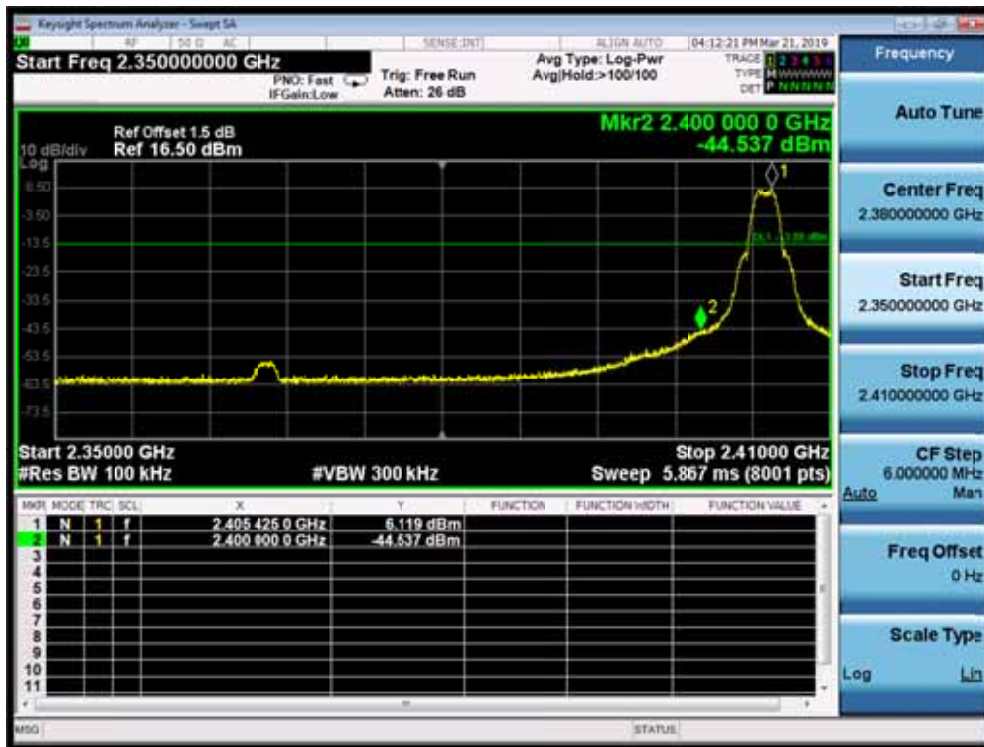

6. Radiated Emission Band Edge

6.1. Test Equipment

Radiated Emission Band Edge / AC-5					
Instrument	Manufacturer	Type No.	Serial No.	Cal. Date	Cal. Due Date
EMI Receiver	Agilent	N9038A	MY51210196	2018.07.16	2019.07.15
Pre-Amplifier	Miteq	NSP1800-25	1364185	2018.05.03	2019.05.02
DRG Horn Antenna	ETS-Lindgren	3117	00167055	2018.07.12	2019.07.11
Broad-Band Horn Antenna	Schwarzbeck	BBHA9170	294	2018.09.18	2019.09.17
Coaxial Cable	Huber+Suhner	SUCOFLEX 106	AC5-C1	2019.02.28	2020.02.27
Coaxial Cable	Huber+Suhner	SUCOFLEX 106	AC5-C2	2019.02.28	2020.02.27
Temperature/Humidity Meter	Zhichen	ZC1-2	AC5-TH	2019.01.05	2020.01.04

6.2. Test Setup

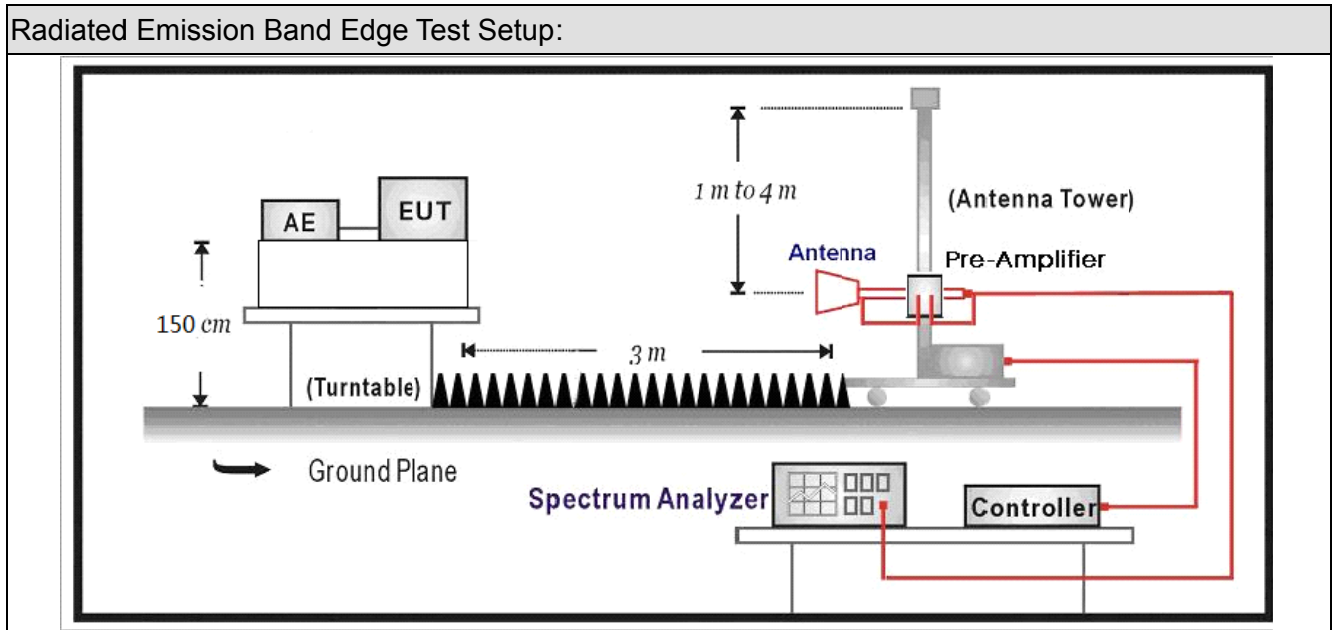

6.3. Limit



Band edge Limit				
Frequency bands (MHz)	Detector	Limit (dB μ V/m)	RBW (MHz)	Distance (m)
2310-2390	PK	74	1	3
2483.5-2500	AV	54	1	3

Note: The field strength of emissions appearing within these frequency bands shall not exceed the limits.

6.4. Test Procedure

Test Method			
	References Rule	Chapter	Description
<input checked="" type="checkbox"/>	ANSI C63.10	6.10	Band-edge testing
	<input checked="" type="checkbox"/> ANSI C63.10	6.10.5	Restricted-band band-edge measurements
	<input type="checkbox"/> ANSI C63.10	6.10.6	Marker-delta method
<input checked="" type="checkbox"/>	ANSI C63.10	11.12	Emissions in restricted frequency bands
	<input checked="" type="checkbox"/> ANSI C63.10	11.12.1	Radiated emission measurements
	<input checked="" type="checkbox"/> ANSI C63.10	11.12.2.7	Radiated spurious emission test
<input type="checkbox"/>	ANSI C63.10	6.4	Radiated emissions from unlicensed wireless devices below 30 MHz
<input type="checkbox"/>	ANSI C63.10	6.5	Radiated emissions from unlicensed wireless devices in the frequency range of 30 MHz to 1000 MHz
<input checked="" type="checkbox"/>	ANSI C63.10	6.6	Radiated emissions from unlicensed wireless devices above 1 GHz
	<input type="checkbox"/> ANSI C63.10	11.12.2.3	Quasi-peak measurement procedure
	<input type="checkbox"/> ANSI C63.10	11.12.2.4	Peak power measurement procedure
	<input type="checkbox"/> ANSI C63.10	11.12.2.5	Average power measurement procedures
	<input type="checkbox"/> ANSI C63.10	11.12.2.5.1	Trace averaging with continuous EUT transmission at full power
	<input type="checkbox"/> ANSI C63.10	11.12.2.5.2	Trace averaging across ON and OFF times of the EUT transmissions followed by duty cycle correction
	<input type="checkbox"/> ANSI C63.10	11.12.2.5.3	Reduced VBW averaging across ON and OFF times of the EUT transmissions with max hold

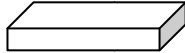
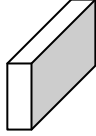
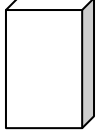
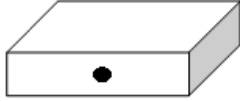
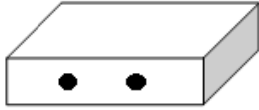
6.5. EUT test definition

Item	Radiated Emission Band Edge			
Device Category	<input type="checkbox"/>	Fixed point-to-point		
	<input type="checkbox"/>	Emit multiple directional beams, simultaneously or sequentially		
	<input checked="" type="checkbox"/>	Other cases		
Test mode	Mode 1			
Test method	<input checked="" type="checkbox"/>	Radiated		
		X Axis	Y Axis	Z Axis
				
		Worst Axis <input checked="" type="checkbox"/>	Worst Axis <input type="checkbox"/>	Worst Axis <input type="checkbox"/>
	<input type="checkbox"/>	Conducted		
	<input type="checkbox"/>	Chain 0		
				
	<input type="checkbox"/>	Chain 0	Chain 1	
				
	<input type="checkbox"/>	Chain 0	Chain 1	Chain 2
				

6.6. Duty Cycle

Test Mode	Tx On (ms)	Tx Off (ms)	Reduced VBW (Hz)	Tx On + Tx Off (ms)	Duty Cycle
Zigbee	N/A	N/A	10	N/A	100%

Mode1

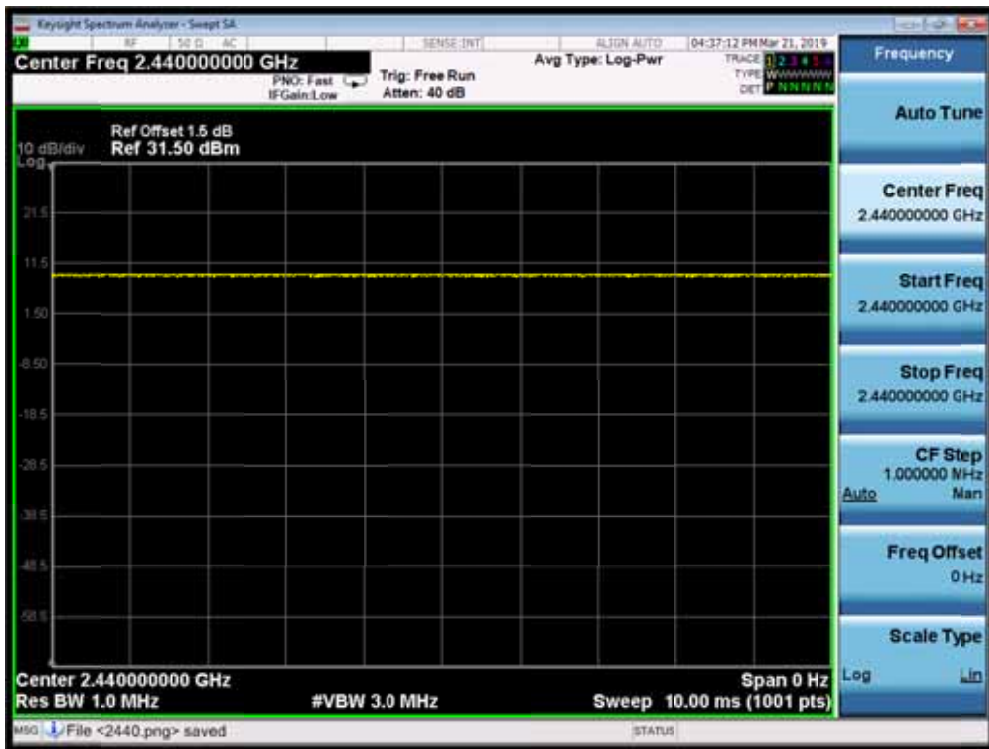

6.7 Test Result

Muruta:

Engineer: YULIU	
Site: AC5	Time: 2019/03/08 - 15:56
Limit: FCC_Part15.209_RE(3m)	Margin: 0
Probe: Horn_3117_00167055(1-18GHz)	Polarity: Vertical
EUT:LED LAMP	Power: AC 120V/60Hz
Note: Mode1:Transmit at 2405Mhz by Zigbee	

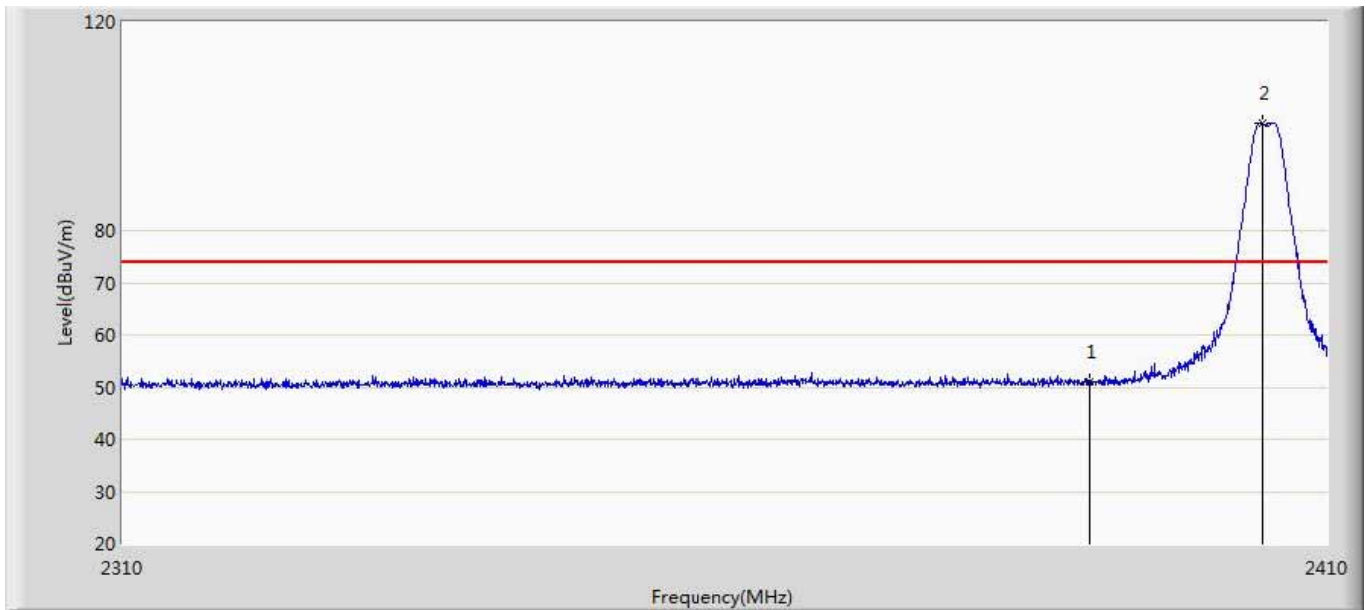

No	Mark	Frequency (MHz)	Measure Level (dBuV/m)	Reading Level (dBuV)	Over Limit (dB)	Limit (dBuV/m)	Factor (dB)	Type
1		2390.000	50.890	15.208	-23.110	74.000	35.682	PK
2	*	2404.500	100.611	64.892	26.611	74.000	35.719	PK

Engineer: YULIU	
Site: AC5	Time: 2019/03/21 - 20:43
Limit: FCC_Part15.209_RE(3m)	Margin: 0
Probe: Horn_3117_00167055(1-18GHz)	Polarity: Vertical
EUT:LED LAMP	Power: AC 120V/60Hz
Note: Mode1:Transmit at 2405Mhz by Zigbee	

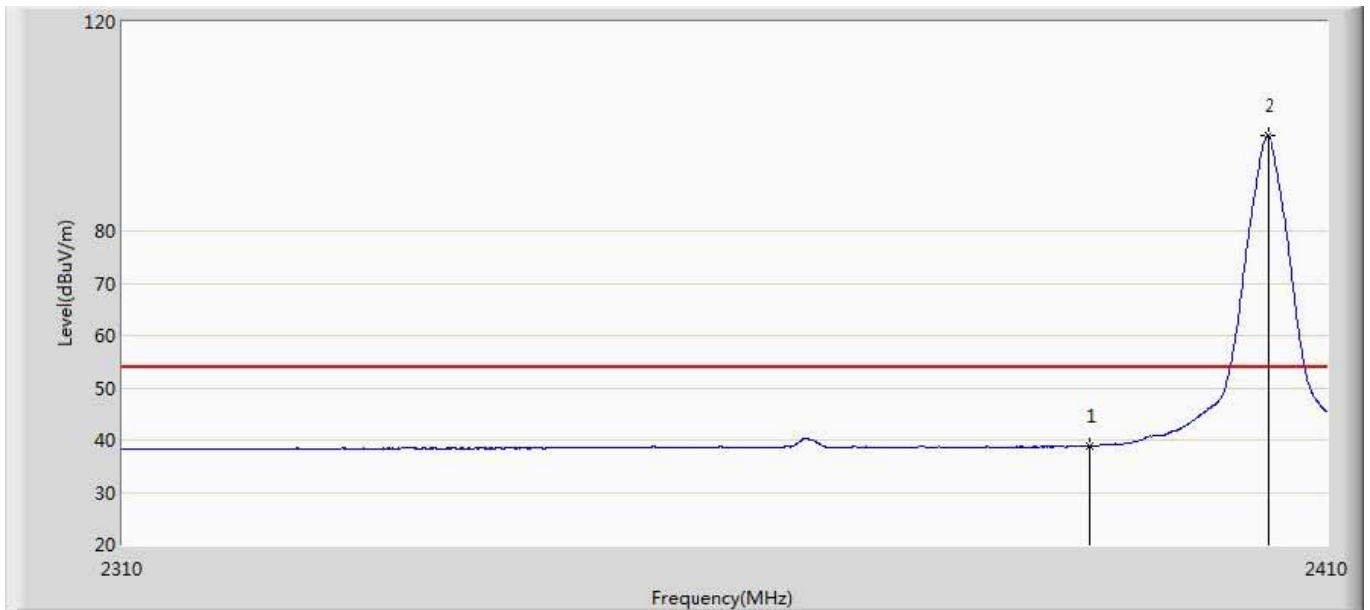

No	Mark	Frequency (MHz)	Measure Level (dBuV/m)	Reading Level (dBuV)	Over Limit (dB)	Limit (dBuV/m)	Factor (dB)	Type
1		2390.000	38.896	3.214	-15.104	54.000	35.682	AV
2	*	2405.000	98.184	62.463	44.184	54.000	35.721	AV

Engineer: YULIU	
Site: AC5	Time: 2019/03/21 - 20:44
Limit: FCC_Part15.209_RE(3m)	Margin: 0
Probe: Horn_3117_00167055(1-18GHz)	Polarity: Horizontal
EUT:LED LAMP	Power: AC 120V/60Hz
Note: Mode1:Transmit at 2405Mhz by Zigbee	

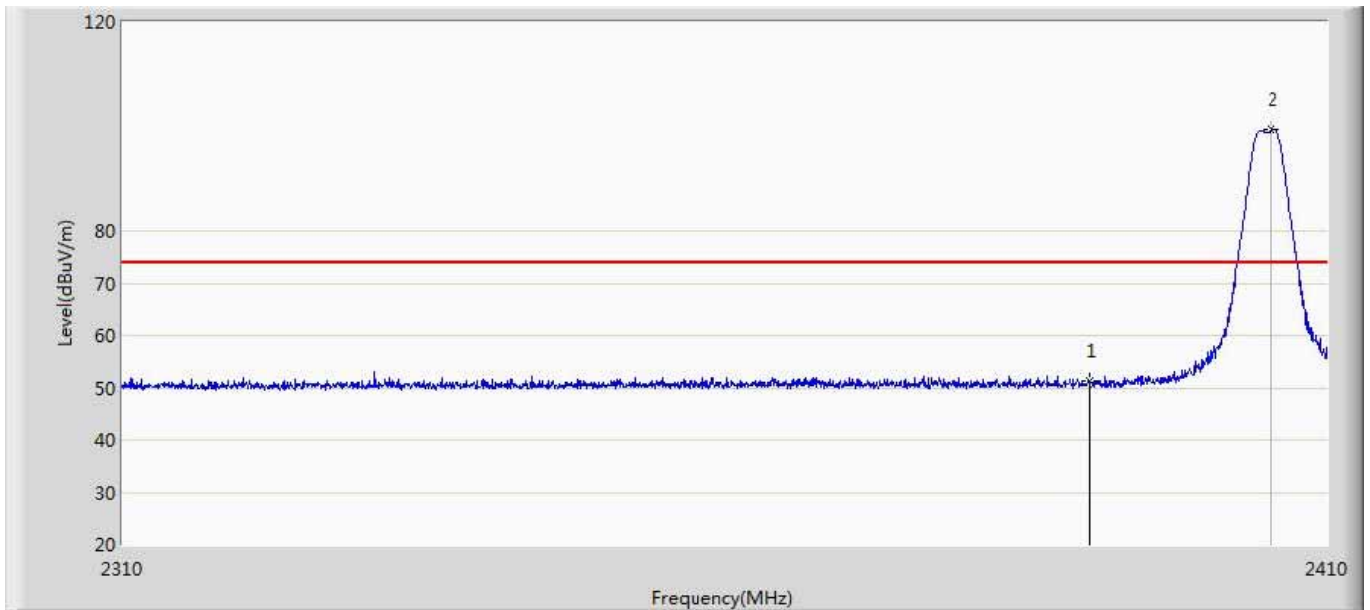

No	Mark	Frequency (MHz)	Measure Level (dBuV/m)	Reading Level (dBuV)	Over Limit (dB)	Limit (dBuV/m)	Factor (dB)	Type
1		2390.000	51.309	15.627	-22.691	74.000	35.682	PK
2	*	2405.300	99.357	63.635	25.357	74.000	35.721	PK

Engineer: YULIU	
Site: AC5	Time: 2019/03/21 - 20:47
Limit: FCC_Part15.209_RE(3m)	Margin: 0
Probe: Horn_3117_00167055(1-18GHz)	Polarity: Horizontal
EUT:LED LAMP	Power: AC 120V/60Hz
Note: Mode1:Transmit at 2405Mhz by Zigbee	

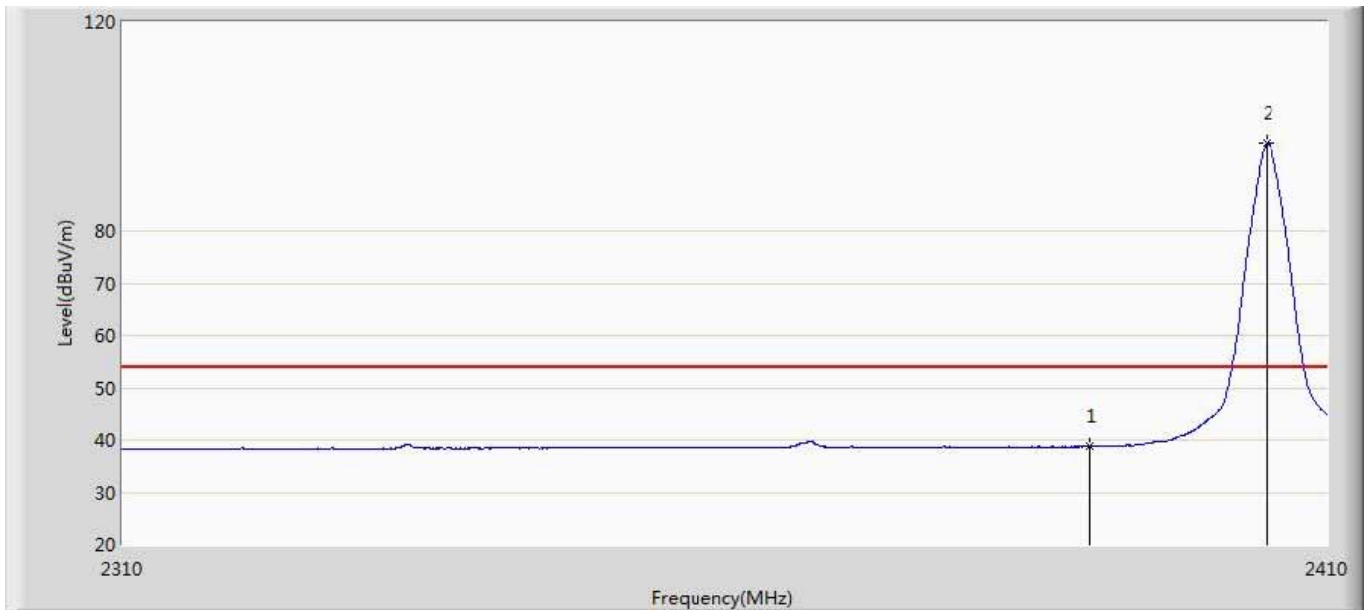

No	Mark	Frequency (MHz)	Measure Level (dBuV/m)	Reading Level (dBuV)	Over Limit (dB)	Limit (dBuV/m)	Factor (dB)	Type
1		2390.000	38.792	3.110	-15.208	54.000	35.682	AV
2	*	2404.850	96.675	60.955	42.675	54.000	35.721	AV

Engineer: YULIU	
Site: AC5	Time: 2019/03/21 - 20:49
Limit: FCC_Part15.209_RE(3m)	Margin: 0
Probe: Horn_3117_00167055(1-18GHz)	Polarity: Vertical
EUT:LED LAMP	Power: AC 120V/60Hz
Note: Mode1:Transmit at 2480Mhz by Zigbee	

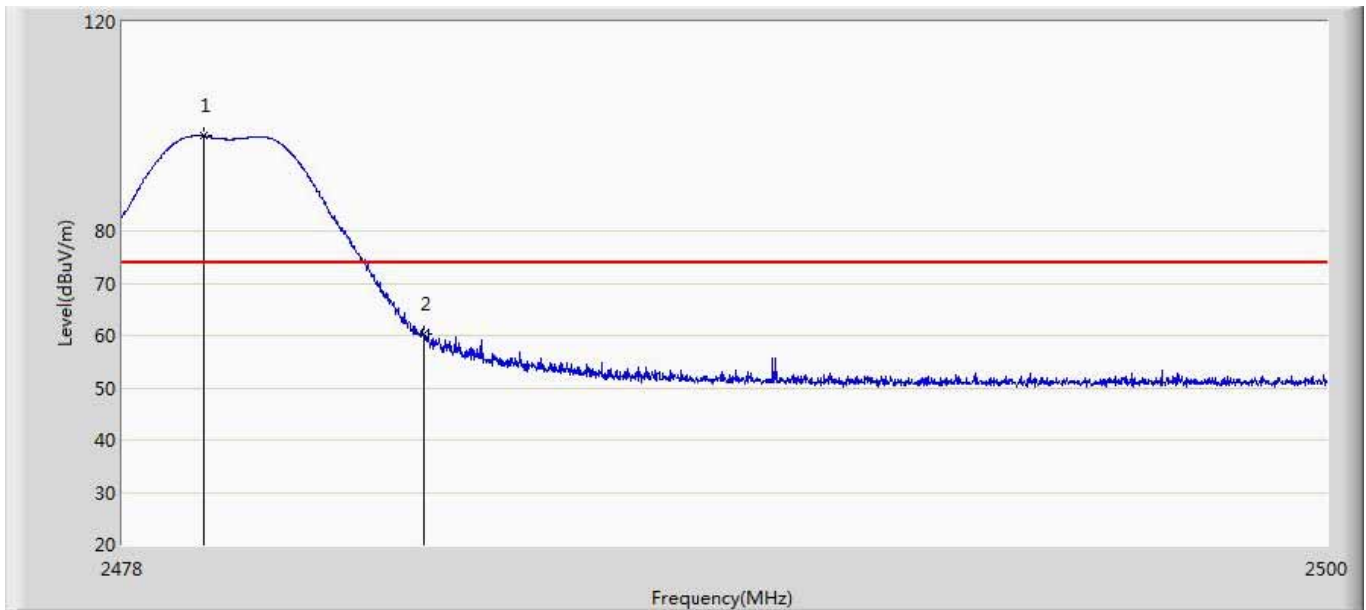

No	Mark	Frequency (MHz)	Measure Level (dBuV/m)	Reading Level (dBuV)	Over Limit (dB)	Limit (dBuV/m)	Factor (dB)	Type
1	*	2479.496	98.142	62.279	24.142	74.000	35.863	PK
2		2483.500	60.363	24.471	-13.637	74.000	35.891	PK

Engineer: YULIU	
Site: AC5	Time: 2019/03/21 - 20:52
Limit: FCC_Part15.209_RE(3m)	Margin: 0
Probe: Horn_3117_00167055(1-18GHz)	Polarity: Vertical
EUT:LED LAMP	Power: AC 120V/60Hz
Note: Mode1:Transmit at 2480Mhz by Zigbee	

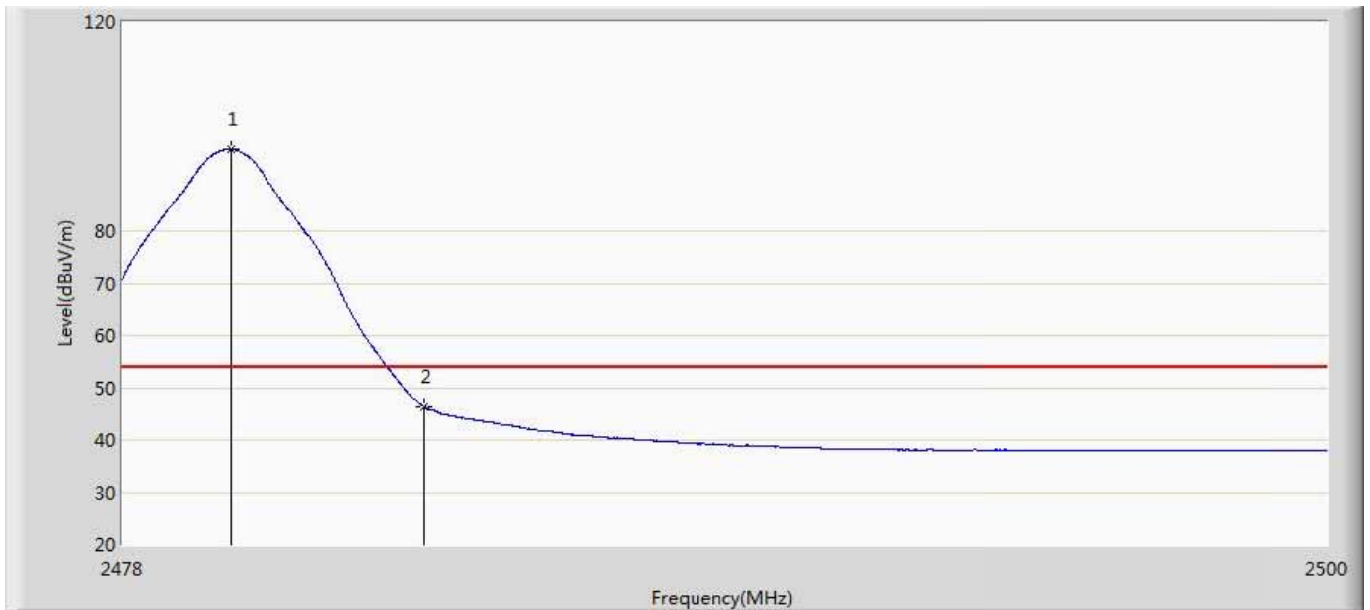

No	Mark	Frequency (MHz)	Measure Level (dBuV/m)	Reading Level (dBuV)	Over Limit (dB)	Limit (dBuV/m)	Factor (dB)	Type
1	*	2479.980	95.661	59.795	41.661	54.000	35.866	AV
2		2483.500	46.396	10.504	-7.604	54.000	35.891	AV

Engineer: YULIU	
Site: AC5	Time: 2019/03/21 - 20:54
Limit: FCC_Part15.209_RE(3m)	Margin: 0
Probe: Horn_3117_00167055(1-18GHz)	Polarity: Horizontal
EUT:LED LAMP	Power: AC 120V/60Hz
Note: Mode1:Transmit at 2480Mhz by Zigbee	

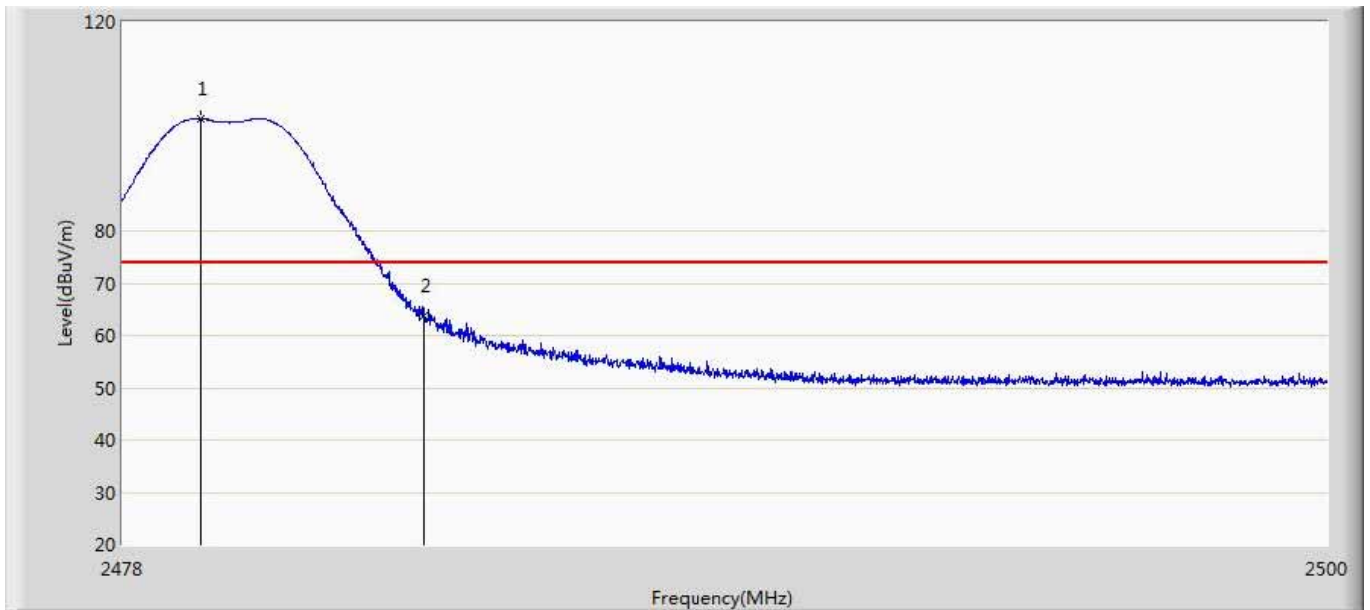

No	Mark	Frequency (MHz)	Measure Level (dBuV/m)	Reading Level (dBuV)	Over Limit (dB)	Limit (dBuV/m)	Factor (dB)	Type
1	*	2479.430	101.440	65.578	27.440	74.000	35.863	PK
2		2483.500	63.702	27.810	-10.298	74.000	35.891	PK

Engineer: YULIU	
Site: AC5	Time: 2019/03/21 - 20:56
Limit: FCC_Part15.209_RE(3m)	Margin: 0
Probe: Horn_3117_00167055(1-18GHz)	Polarity: Horizontal
EUT:LED LAMP	Power: AC 120V/60Hz
Note: Mode1:Transmit at 2480Mhz by Zigbee	

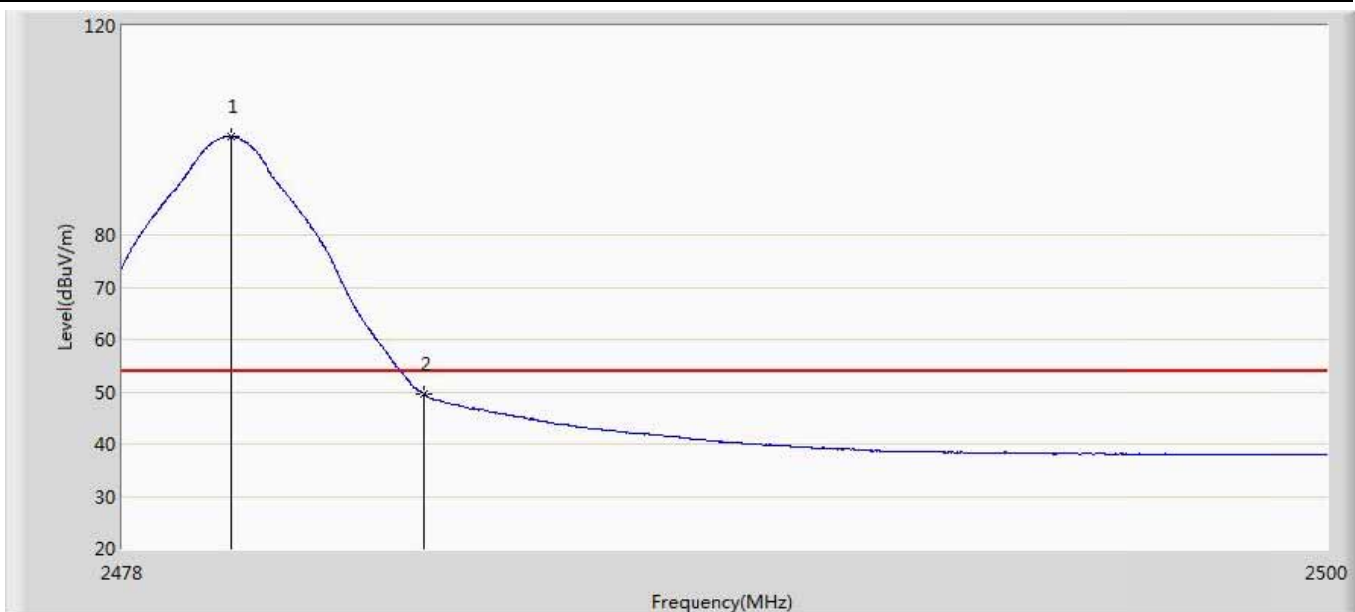

No	Mark	Frequency (MHz)	Measure Level (dBuV/m)	Reading Level (dBuV)	Over Limit (dB)	Limit (dBuV/m)	Factor (dB)	Type
1	*	2479.980	98.762	62.896	44.762	54.000	35.866	AV
2		2483.500	49.596	13.704	-4.404	54.000	35.891	AV

Diodes:

Engineer: YULIU	
Site: AC5	Time: 2019/03/08 - 15:56
Limit: FCC_Part15.209_RE(3m)	Margin: 0
Probe: Horn_3117_00167055(1-18GHz)	Polarity: Vertical
EUT: LED LAMP	Power: AC 120V/60Hz
Note: Mode1:Transmit at 2405Mhz by Zigbee	

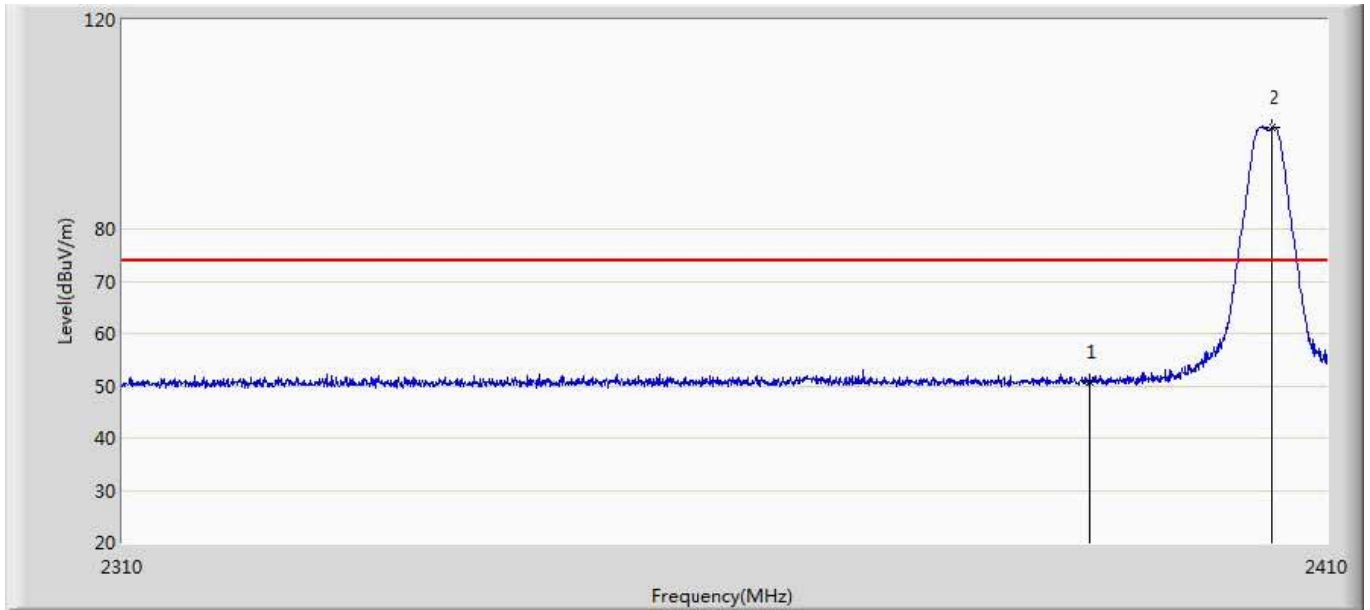

No	Mark	Frequency (MHz)	Measure Level (dBuV/m)	Reading Level (dBuV)	Over Limit (dB)	Limit (dBuV/m)	Factor (dB)	Type
1		2390.000	50.831	15.149	-23.169	74.000	35.682	PK
2	*	2405.350	99.388	63.666	25.388	74.000	35.721	PK

Engineer: YULIU	
Site: AC5	Time: 2019/03/24 - 17:25
Limit: FCC_Part15.209_RE(3m)	Margin: 0
Probe: Horn_3117_00167055(1-18GHz)	Polarity: Vertical
EUT: LED LAMP	Power: AC 120V/60Hz
Note: Mode1:Transmit at 2405Mhz by Zigbee	

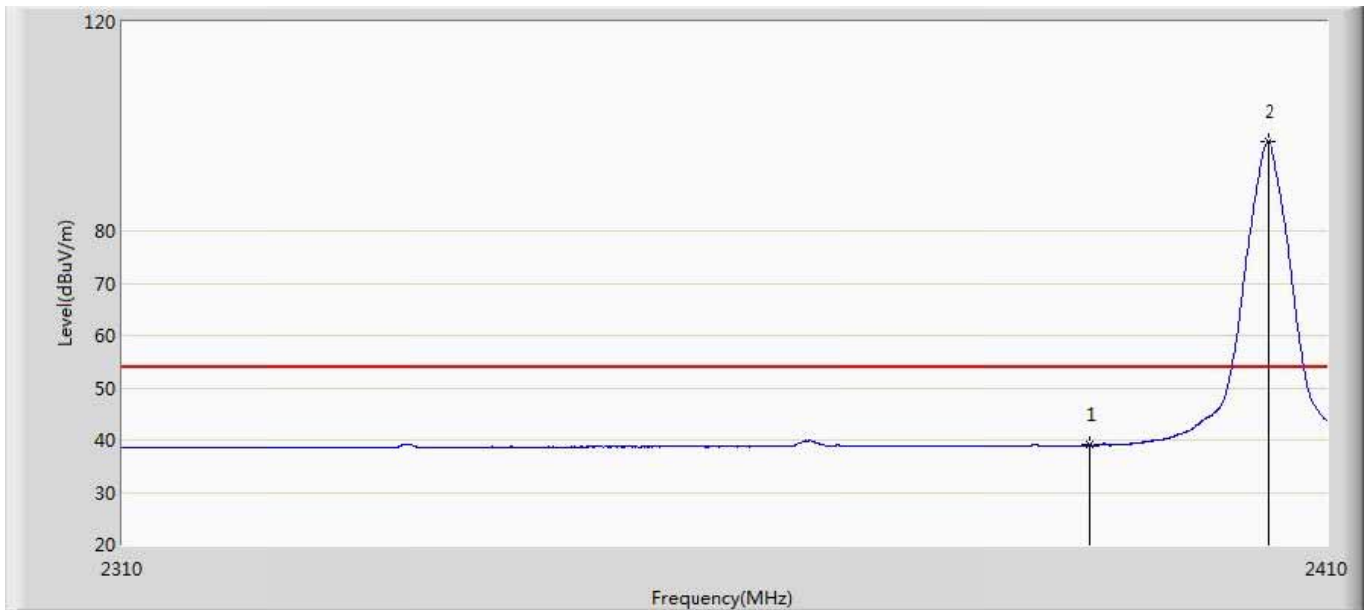

No	Mark	Frequency (MHz)	Measure Level (dBuV/m)	Reading Level (dBuV)	Over Limit (dB)	Limit (dBuV/m)	Factor (dB)	Type
1		2390.000	39.020	3.338	-14.980	54.000	35.682	AV
2	*	2405.000	97.100	61.379	43.100	54.000	35.721	AV

Engineer: YULIU	
Site: AC5	Time: 2019/03/24 - 17:28
Limit: FCC_Part15.209_RE(3m)	Margin: 0
Probe: Horn_3117_00167055(1-18GHz)	Polarity: Horizontal
EUT: LED LAMP	Power: AC 120V/60Hz
Note: Mode1:Transmit at 2405Mhz by Zigbee	

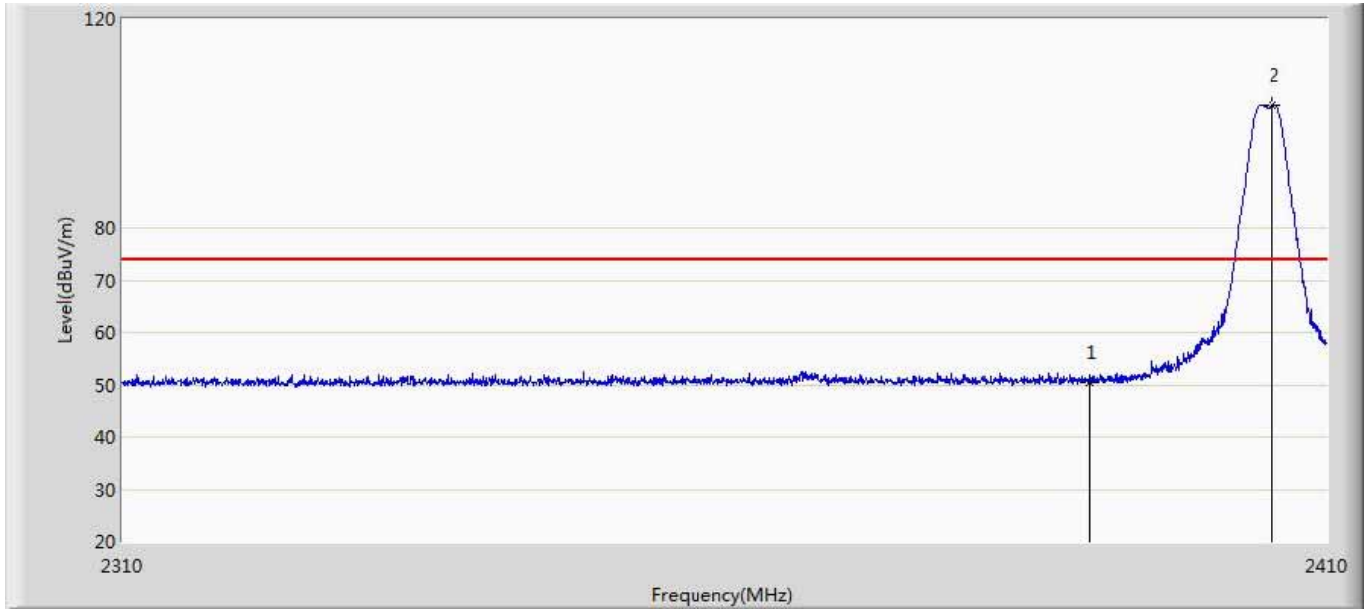

No	Mark	Frequency (MHz)	Measure Level (dBuV/m)	Reading Level (dBuV)	Over Limit (dB)	Limit (dBuV/m)	Factor (dB)	Type
1		2390.000	50.466	14.784	-23.534	74.000	35.682	PK
2	*	2405.350	103.498	67.776	29.498	74.000	35.721	PK

Engineer: YULIU	
Site: AC5	Time: 2019/03/24 - 17:30
Limit: FCC_Part15.209_RE(3m)	Margin: 0
Probe: Horn_3117_00167055(1-18GHz)	Polarity: Horizontal
EUT: LED LAMP	Power: AC 120V/60Hz
Note: Mode1:Transmit at 2405Mhz by Zigbee	

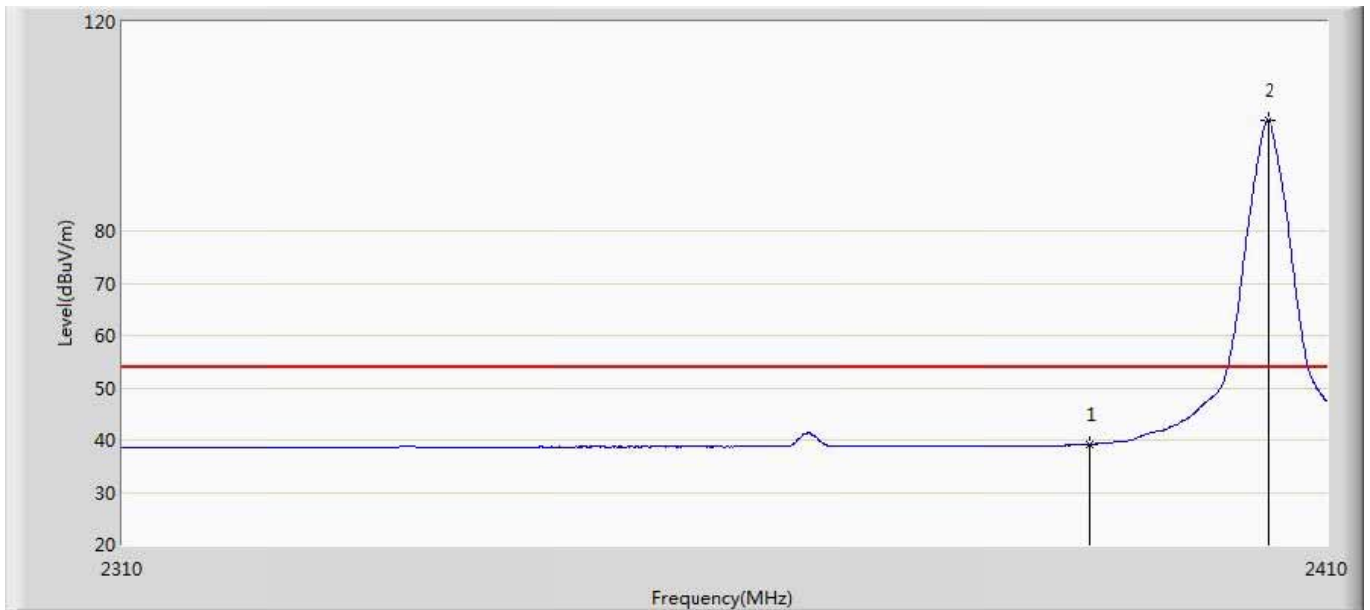

No	Mark	Frequency (MHz)	Measure Level (dBuV/m)	Reading Level (dBuV)	Over Limit (dB)	Limit (dBuV/m)	Factor (dB)	Type
1		2390.000	39.169	3.487	-14.831	54.000	35.682	AV
2	*	2405.000	101.174	65.453	47.174	54.000	35.721	AV

Engineer: YULIU	
Site: AC5	Time: 2019/03/24 - 17:32
Limit: FCC_Part15.209_RE(3m)	Margin: 0
Probe: Horn_3117_00167055(1-18GHz)	Polarity: Vertical
EUT: LED LAMP	Power: AC 120V/60Hz
Note: Mode1:Transmit at 2480Mhz by Zigbee	

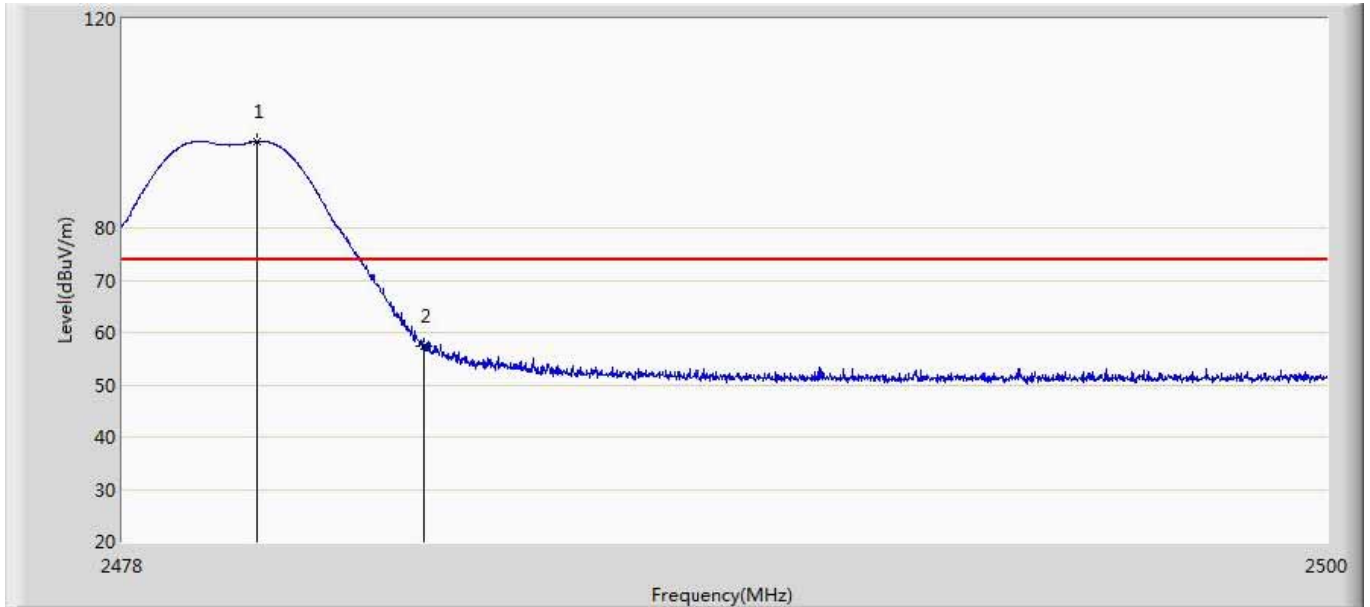

No	Mark	Frequency (MHz)	Measure Level (dBuV/m)	Reading Level (dBuV)	Over Limit (dB)	Limit (dBuV/m)	Factor (dB)	Type
1	*	2480.431	96.566	60.697	22.566	74.000	35.870	PK
2		2483.500	57.360	21.468	-16.640	74.000	35.891	PK

Engineer: YULIU	
Site: AC5	Time: 2019/03/24 - 17:34
Limit: FCC_Part15.209_RE(3m)	Margin: 0
Probe: Horn_3117_00167055(1-18GHz)	Polarity: Vertical
EUT: LED LAMP	Power: AC 120V/60Hz
Note: Mode1:Transmit at 2480Mhz by Zigbee	

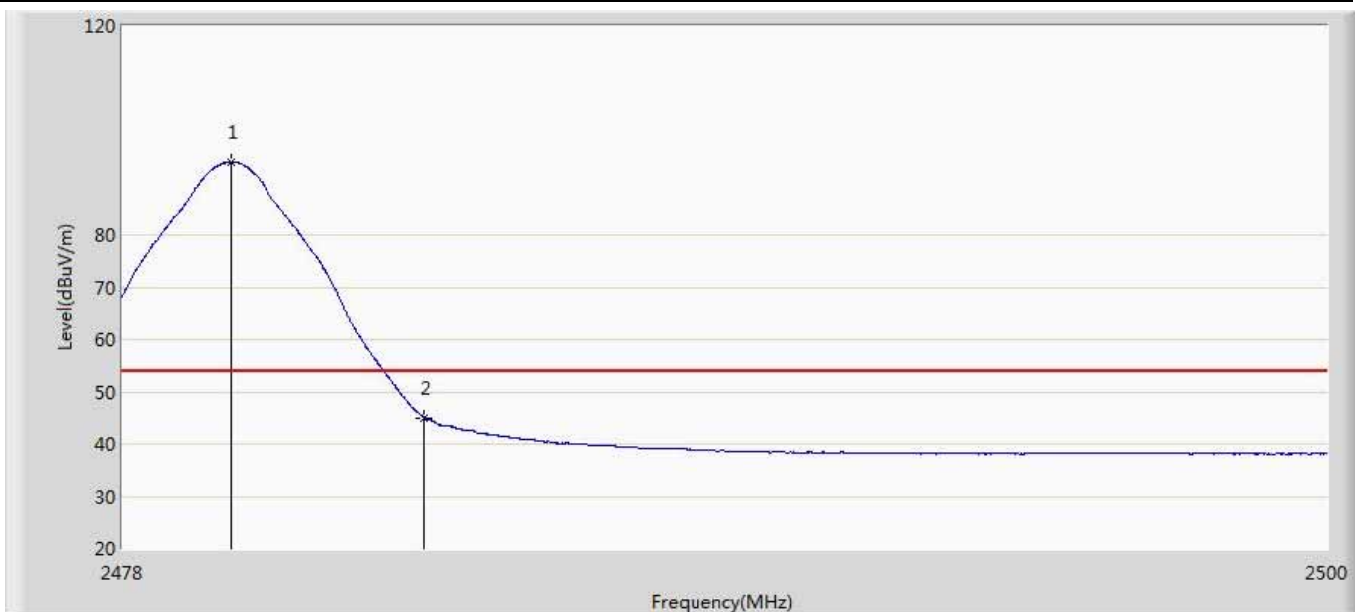

No	Mark	Frequency (MHz)	Measure Level (dBuV/m)	Reading Level (dBuV)	Over Limit (dB)	Limit (dBuV/m)	Factor (dB)	Type
1	*	2479.980	93.923	58.057	39.923	54.000	35.866	AV
2		2483.500	45.025	9.133	-8.975	54.000	35.891	AV

Engineer: YULIU	
Site: AC5	Time: 2019/03/24 - 17:36
Limit: FCC_Part15.209_RE(3m)	Margin: 0
Probe: Horn_3117_00167055(1-18GHz)	Polarity: Horizontal
EUT: LED LAMP	Power: AC 120V/60Hz
Note: Mode1:Transmit at 2480Mhz by Zigbee	

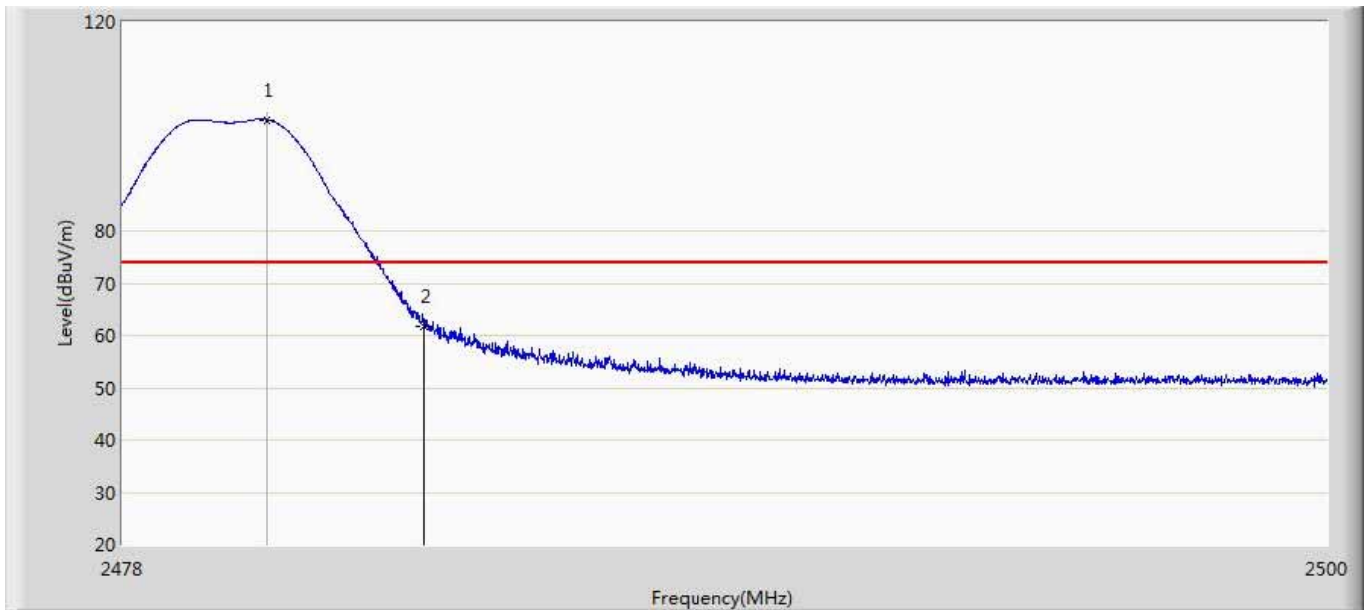

No	Mark	Frequency (MHz)	Measure Level (dBuV/m)	Reading Level (dBuV)	Over Limit (dB)	Limit (dBuV/m)	Factor (dB)	Type
1	*	2480.629	101.278	65.407	27.278	74.000	35.871	PK
2		2483.500	61.607	25.715	-12.393	74.000	35.891	PK

Engineer: YULIU	
Site: AC5	Time: 2019/03/24 - 17:38
Limit: FCC_Part15.209_RE(3m)	Margin: 0
Probe: Horn_3117_00167055(1-18GHz)	Polarity: Horizontal
EUT: LED LAMP	Power: AC 120V/60Hz
Note: Mode1:Transmit at 2480Mhz by Zigbee	

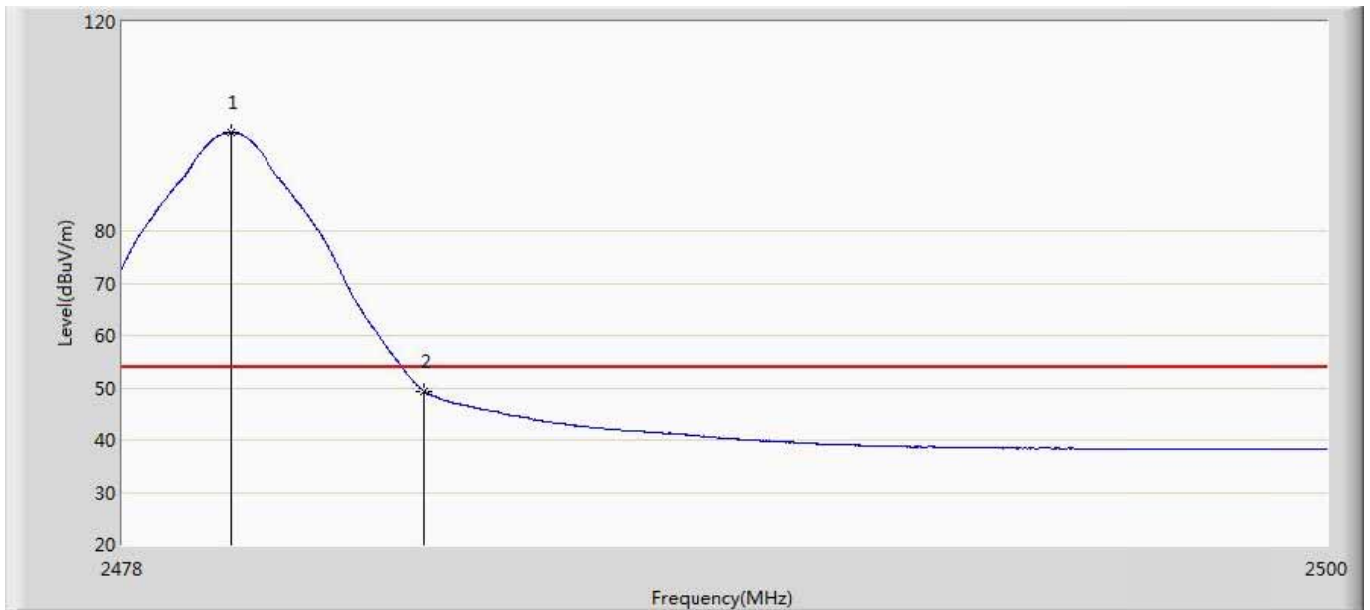

No	Mark	Frequency (MHz)	Measure Level (dBuV/m)	Reading Level (dBuV)	Over Limit (dB)	Limit (dBuV/m)	Factor (dB)	Type
1	*	2479.980	98.761	62.895	44.761	54.000	35.866	AV
2		2483.500	49.325	13.433	-4.675	54.000	35.891	AV

Kdx:

Engineer: YULIU	
Site: AC5	Time: 2019/03/08 - 15:56
Limit: FCC_Part15.209_RE(3m)	Margin: 0
Probe: Horn_3117_00167055(1-18GHz)	Polarity: Vertical
EUT:LED LAMP	Power: AC 120V/60Hz
Note: Mode1:Transmit at 2405Mhz by Zigbee	

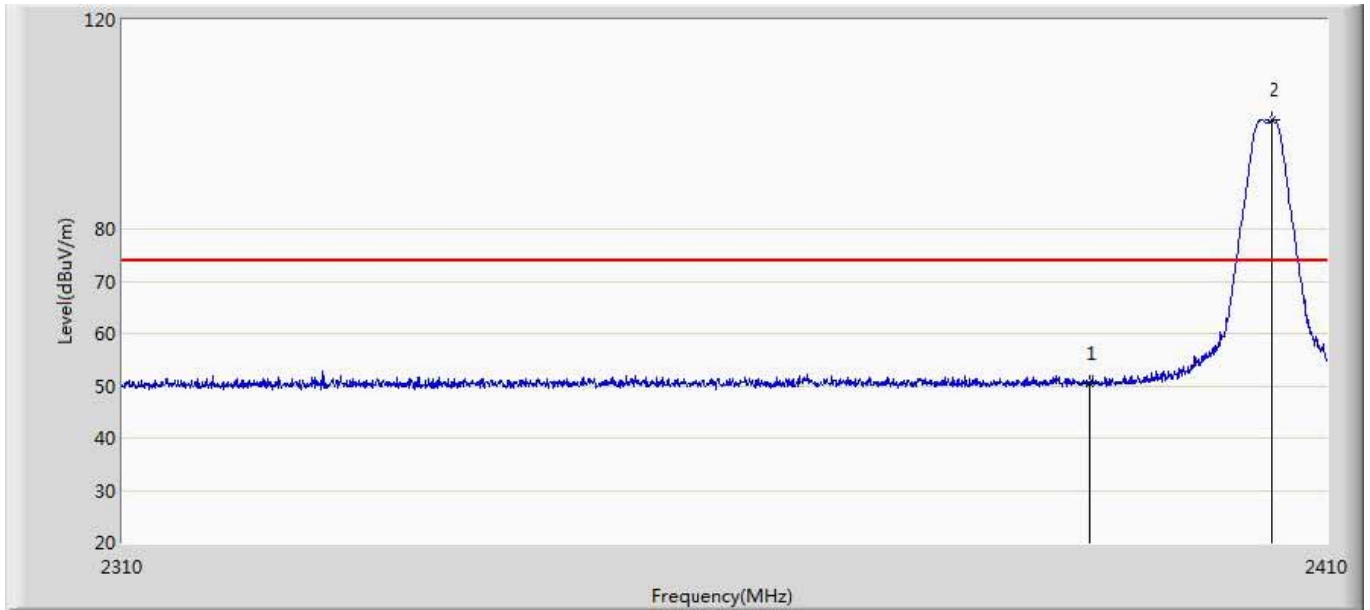

No	Mark	Frequency (MHz)	Measure Level (dBuV/m)	Reading Level (dBuV)	Over Limit (dB)	Limit (dBuV/m)	Factor (dB)	Type
1		2390.000	50.578	14.896	-23.422	74.000	35.682	PK
2	*	2405.350	100.941	65.219	26.941	74.000	35.721	PK

Engineer: YULIU	
Site: AC5	Time: 2019/04/12 - 00:22
Limit: FCC_Part15.209_RE(3m)	Margin: 0
Probe: Horn_3117_00167055(1-18GHz)	Polarity: Vertical
EUT:LED LAMP	Power: AC 120V/60Hz
Note: Mode1:Transmit at 2405Mhz by Zigbee	

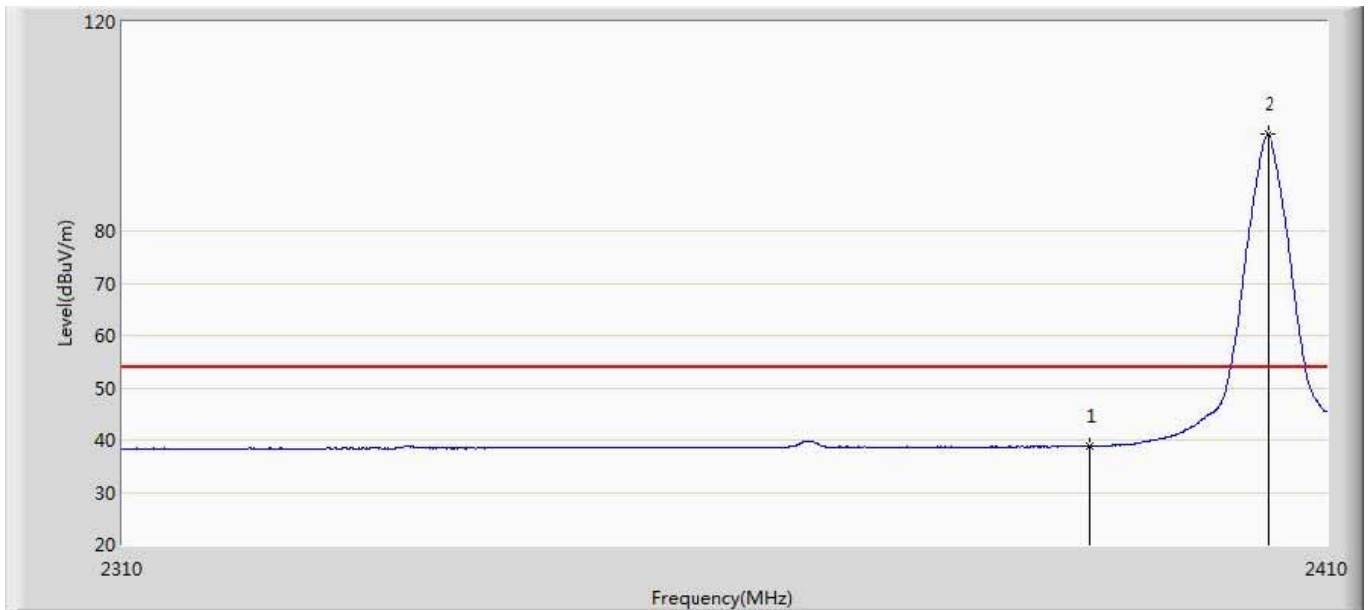

No	Mark	Frequency (MHz)	Measure Level (dBuV/m)	Reading Level (dBuV)	Over Limit (dB)	Limit (dBuV/m)	Factor (dB)	Type
1		2390.000	38.877	3.195	-15.123	54.000	35.682	AV
2	*	2405.000	98.501	62.780	44.501	54.000	35.721	AV

Engineer: YULIU	
Site: AC5	Time: 2019/04/12 - 00:23
Limit: FCC_Part15.209_RE(3m)	Margin: 0
Probe: Horn_3117_00167055(1-18GHz)	Polarity: Horizontal
EUT:LED LAMP	Power: AC 120V/60Hz
Note: Mode1:Transmit at 2405Mhz by Zigbee	

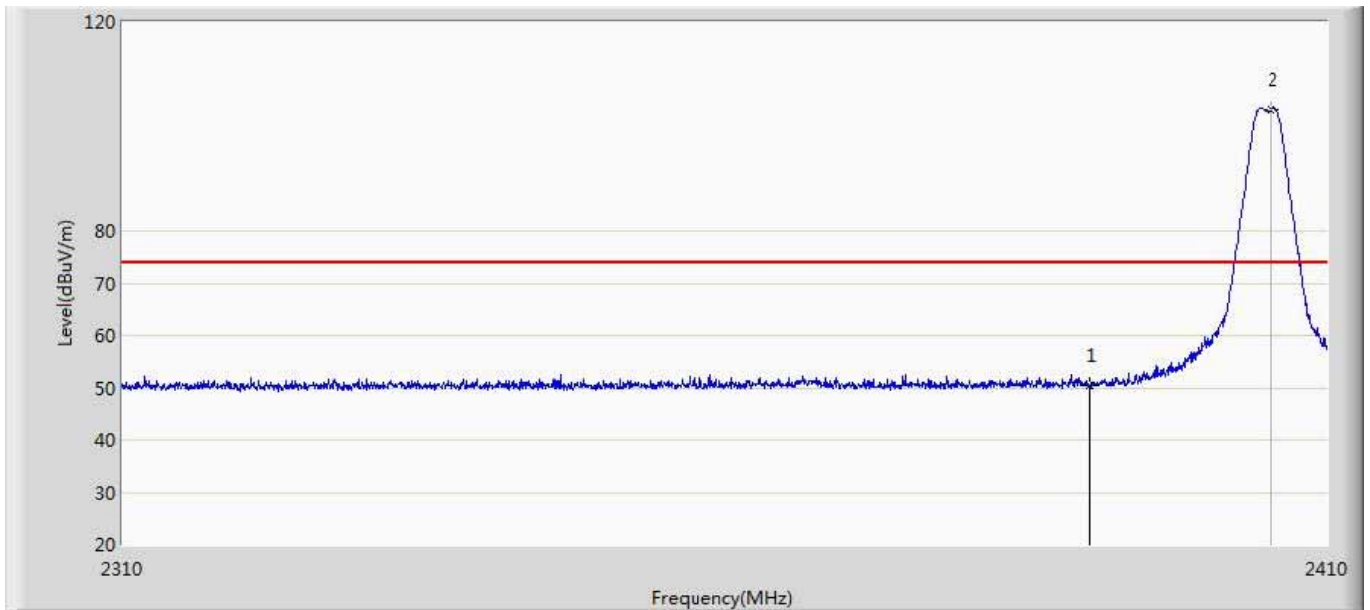

No	Mark	Frequency (MHz)	Measure Level (dBuV/m)	Reading Level (dBuV)	Over Limit (dB)	Limit (dBuV/m)	Factor (dB)	Type
1		2390.000	50.448	14.766	-23.552	74.000	35.682	PK
2	*	2405.250	103.152	67.430	29.152	74.000	35.721	PK

Engineer: YULIU	
Site: AC5	Time: 2019/04/12 - 00:25
Limit: FCC_Part15.209_RE(3m)	Margin: 0
Probe: Horn_3117_00167055(1-18GHz)	Polarity: Horizontal
EUT:LED LAMP	Power: AC 120V/60Hz
Note: Mode1:Transmit at 2405Mhz by Zigbee	

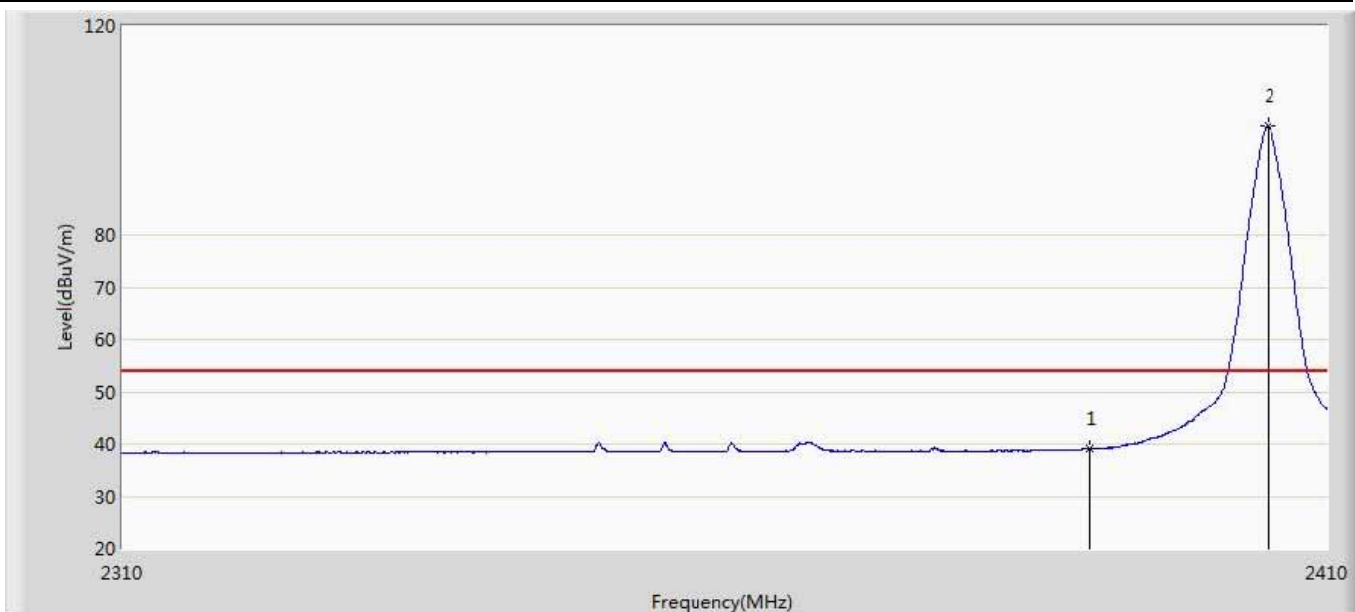

No	Mark	Frequency (MHz)	Measure Level (dBuV/m)	Reading Level (dBuV)	Over Limit (dB)	Limit (dBuV/m)	Factor (dB)	Type
1		2390.000	39.118	3.436	-14.882	54.000	35.682	AV
2	*	2405.000	100.799	65.078	46.799	54.000	35.721	AV

Engineer: YULIU	
Site: AC5	Time: 2019/04/12 - 00:26
Limit: FCC_Part15.209_RE(3m)	Margin: 0
Probe: Horn_3117_00167055(1-18GHz)	Polarity: Vertical
EUT:LED LAMP	Power: AC 120V/60Hz
Note: Mode1:Transmit at 2480Mhz by Zigbee	

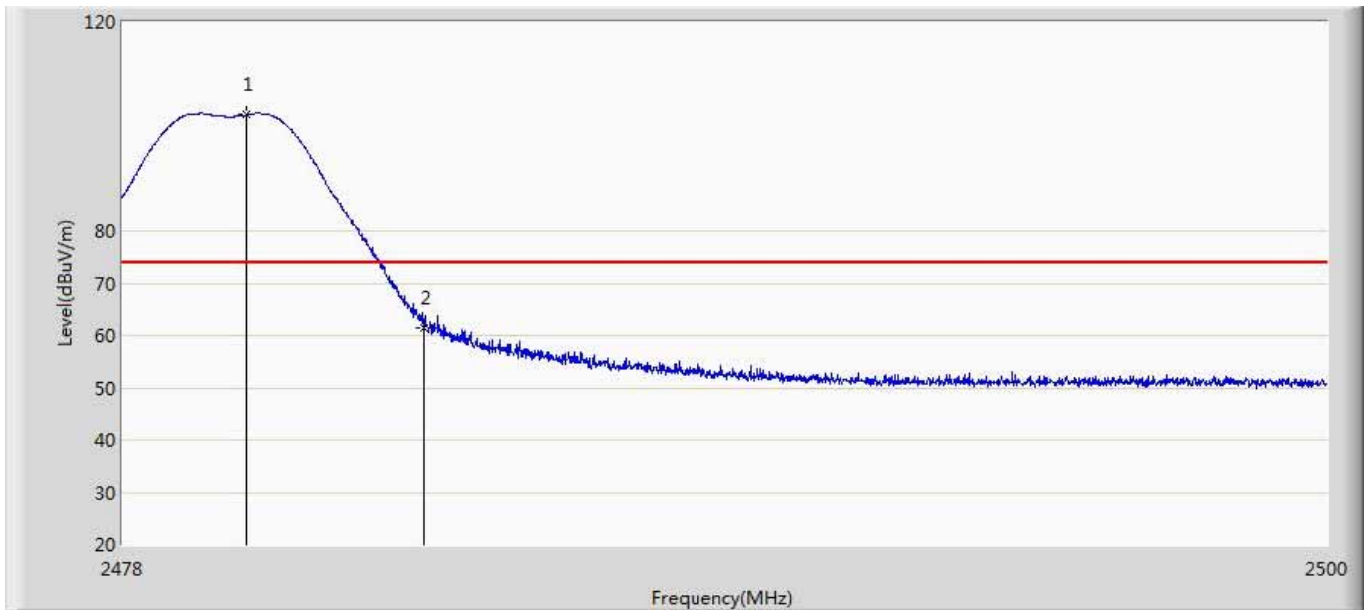

No	Mark	Frequency (MHz)	Measure Level (dBuV/m)	Reading Level (dBuV)	Over Limit (dB)	Limit (dBuV/m)	Factor (dB)	Type
1	*	2480.255	102.177	66.309	28.177	74.000	35.868	PK
2		2483.500	61.540	25.648	-12.460	74.000	35.891	PK

Engineer: YULIU	
Site: AC5	Time: 2019/04/12 - 00:28
Limit: FCC_Part15.209_RE(3m)	Margin: 0
Probe: Horn_3117_00167055(1-18GHz)	Polarity: Vertical
EUT:LED LAMP	Power: AC 120V/60Hz
Note: Mode1:Transmit at 2480Mhz by Zigbee	

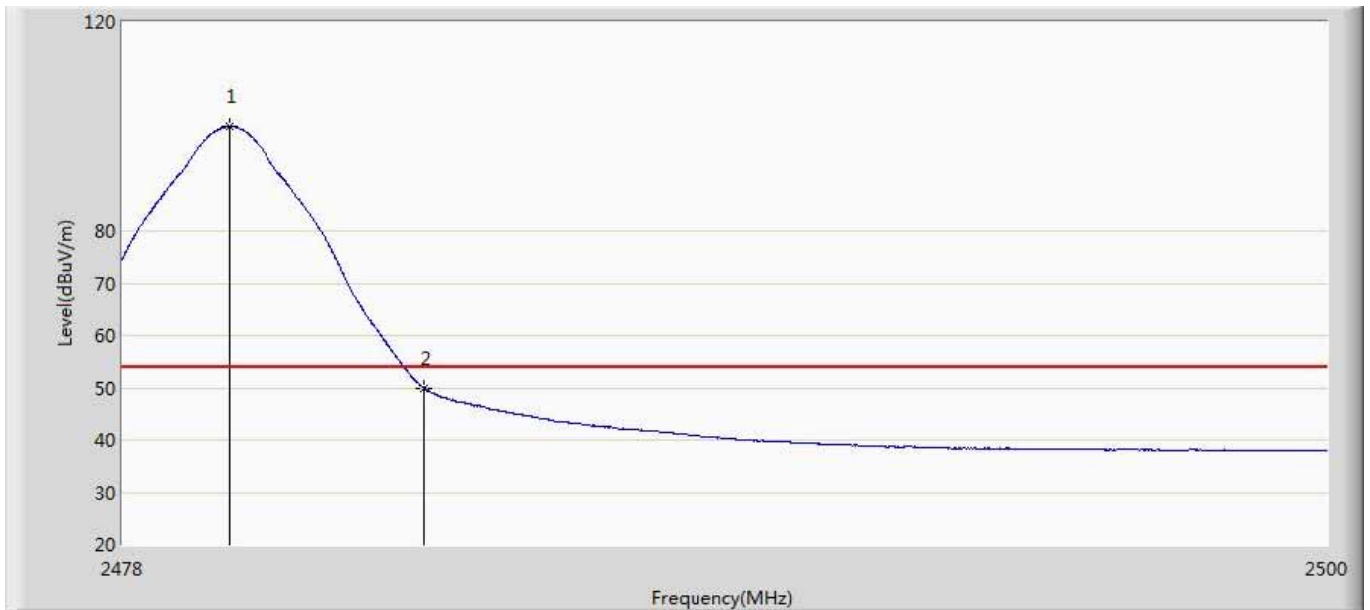

No	Mark	Frequency (MHz)	Measure Level (dBuV/m)	Reading Level (dBuV)	Over Limit (dB)	Limit (dBuV/m)	Factor (dB)	Type
1	*	2479.947	99.933	64.067	45.933	54.000	35.866	AV
2		2483.500	49.936	14.044	-4.064	54.000	35.891	AV

Engineer: YULIU	
Site: AC5	Time: 2019/04/12 - 00:30
Limit: FCC_Part15.209_RE(3m)	Margin: 0
Probe: Horn_3117_00167055(1-18GHz)	Polarity: Horizontal
EUT:LED LAMP	Power: AC 120V/60Hz
Note: Mode1:Transmit at 2480Mhz by Zigbee	

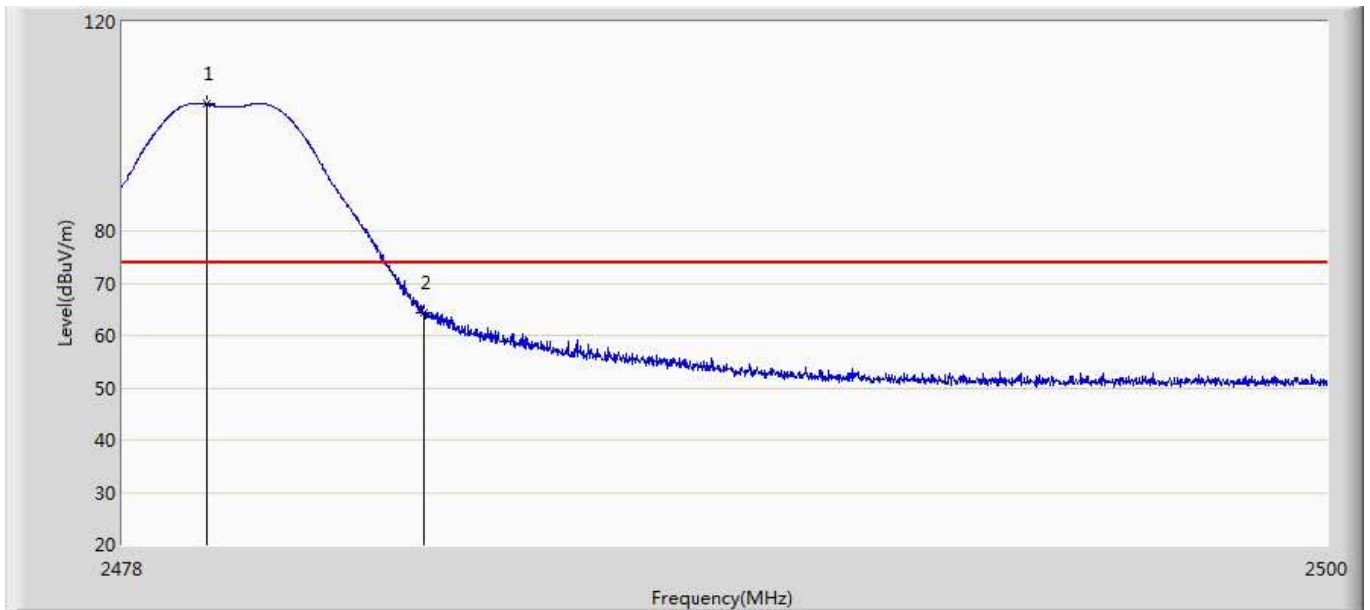

No	Mark	Frequency (MHz)	Measure Level (dBuV/m)	Reading Level (dBuV)	Over Limit (dB)	Limit (dBuV/m)	Factor (dB)	Type
1	*	2479.529	104.347	68.484	30.347	74.000	35.863	PK
2		2483.500	64.337	28.445	-9.663	74.000	35.891	PK

Engineer: YULIU	
Site: AC5	Time: 2019/04/12 - 00:31
Limit: FCC_Part15.209_RE(3m)	Margin: 0
Probe: Horn_3117_00167055(1-18GHz)	Polarity: Horizontal
EUT:LED LAMP	Power: AC 120V/60Hz
Note: Mode1:Transmit at 2480Mhz by Zigbee	

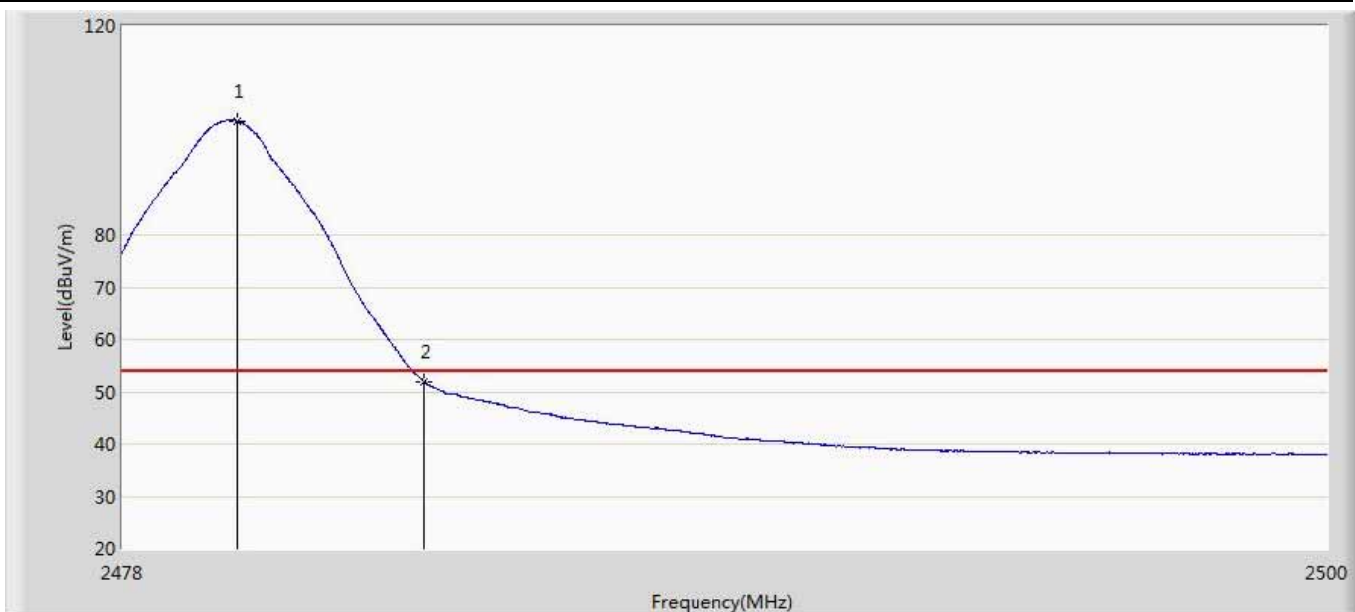

No	Mark	Frequency (MHz)	Measure Level (dBuV/m)	Reading Level (dBuV)	Over Limit (dB)	Limit (dBuV/m)	Factor (dB)	Type
1	*	2480.079	101.839	65.972	47.839	54.000	35.867	AV
2		2483.500	51.888	15.996	-2.112	54.000	35.891	AV

7. Occupied Bandwidth

7.1. Test Equipment

Occupied Bandwidth / TR-8					
Instrument	Manufacturer	Type No.	Serial No.	Cal. Date	Cal. Due Date
Spectrum Analyzer	Agilent	N9010A	MY48030494	2019.02.04	2020.02.03
EXA Spectrum Analyzer	Keysight	N9010A	MY55370495	2018.04.09	2019.04.08
MXA Signal Analyzer	Keysight	N9020A	MY56060147	2018.04.09	2019.04.08
Temperature/Humidity Meter	zhichen	ZC1-2	TR8-TH	2018.04.10	2019.04.09

Note: All equipments are calibrated with traceable calibrations. Each calibration is traceable to the national or international standards.

7.2. Test Setup

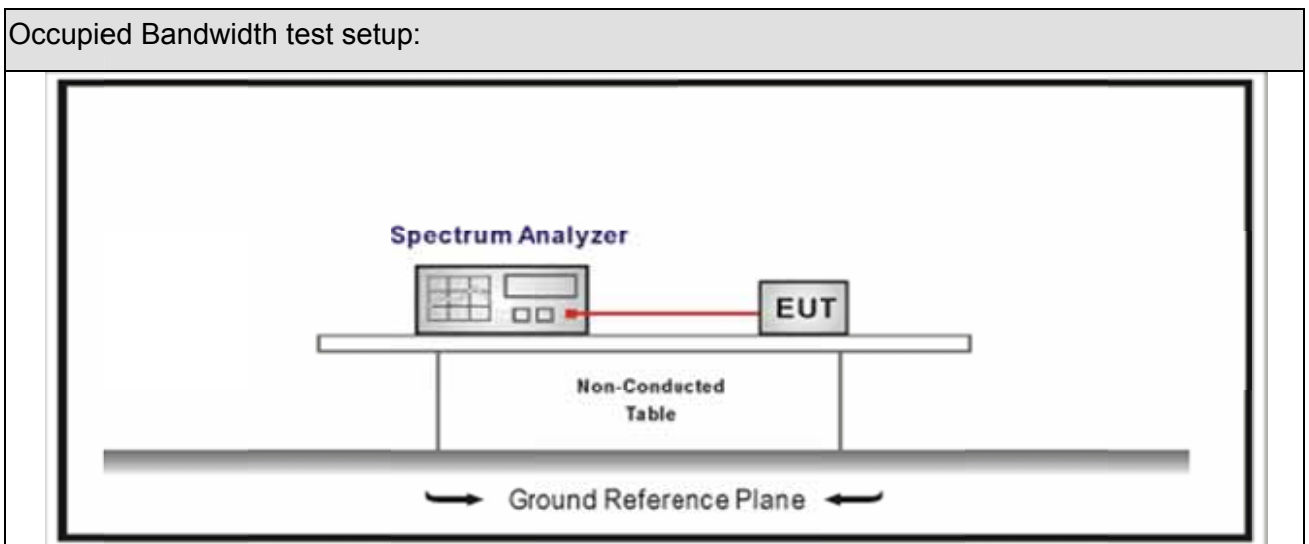



7.3. Limit

Occupied Bandwidth
Systems using digital modulation techniques operate in the 2400-2483.5 MHz. The minimum 6 dB bandwidth shall be at least 500 kHz

7.4. Test Procedure

Test Method			
	Reference Rule	Chapter	Description
<input checked="" type="checkbox"/>	ANSI C63.10	11.8	DTS bandwidth
	<input type="checkbox"/> ANSI C63.10	11.8.1	Option 1
	<input checked="" type="checkbox"/> ANSI C63.10	11.8.2	Option 2

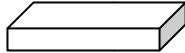
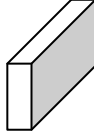
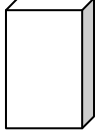
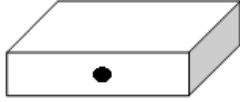
7.5. EUT test definition

Item	Occupied Bandwidth			
Device Category	<input type="checkbox"/>	Fixed point-to-point		
	<input type="checkbox"/>	Emit multiple directional beams, simultaneously or sequentially		
	<input checked="" type="checkbox"/>	Other cases		
Test mode	Mode 1			
Test method	<input type="checkbox"/>	Radiated		
		X Axis	Y Axis	Z Axis
				
		Worst Axis <input type="checkbox"/>	Worst Axis <input type="checkbox"/>	Worst Axis <input type="checkbox"/>
	<input checked="" type="checkbox"/>	Conducted		
	<input checked="" type="checkbox"/>	Chain 0		
				
	<input type="checkbox"/>	Chain 0	Chain 1	
				
	<input type="checkbox"/>	Chain 0	Chain 1	Chain 2
				

7.6. Test Result

Product Name	: LED lamp	Power	: AC 120V/60Hz
Test Mode	: Mode 1	Test Site	: TR-8
Test Date	: 2019.03.15		

Mode	CH.	Test Freq. (MHz)	99% Occupied Bandwidth (kHz)	Limit (kHz)	Result
1	11	2405	2260.1	>500	Pass
1	18	2440	2275.7	>500	Pass
1	39	2480	2283.3	>500	Pass

Mode 1 CH11 (2405MHz)

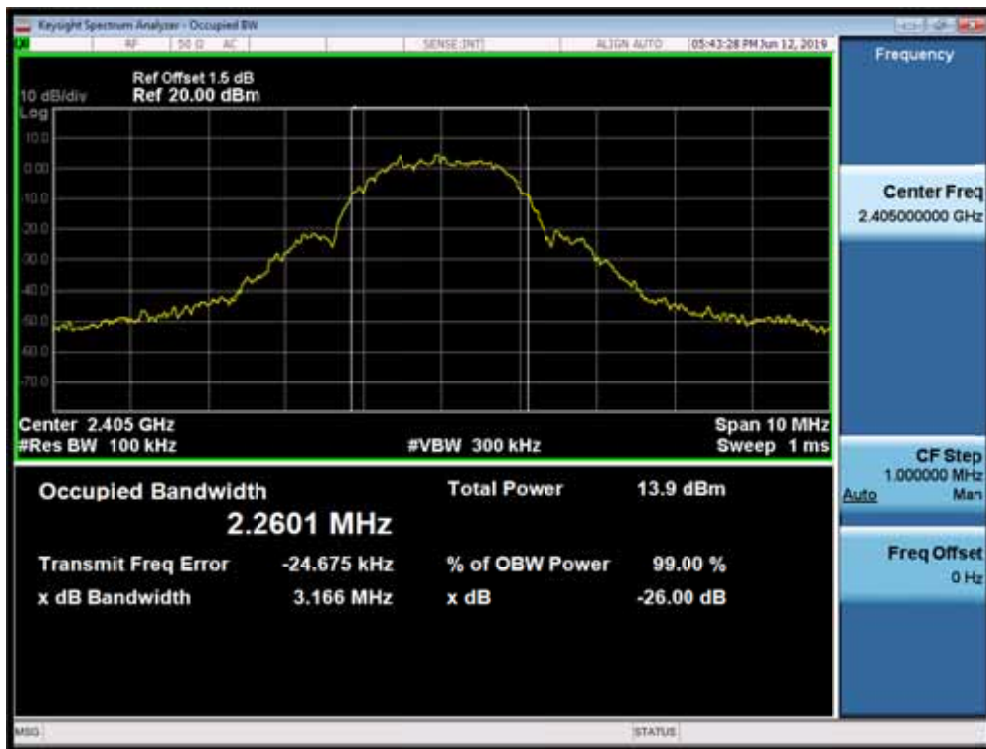

Mode 1 CH18 (2440MHz)

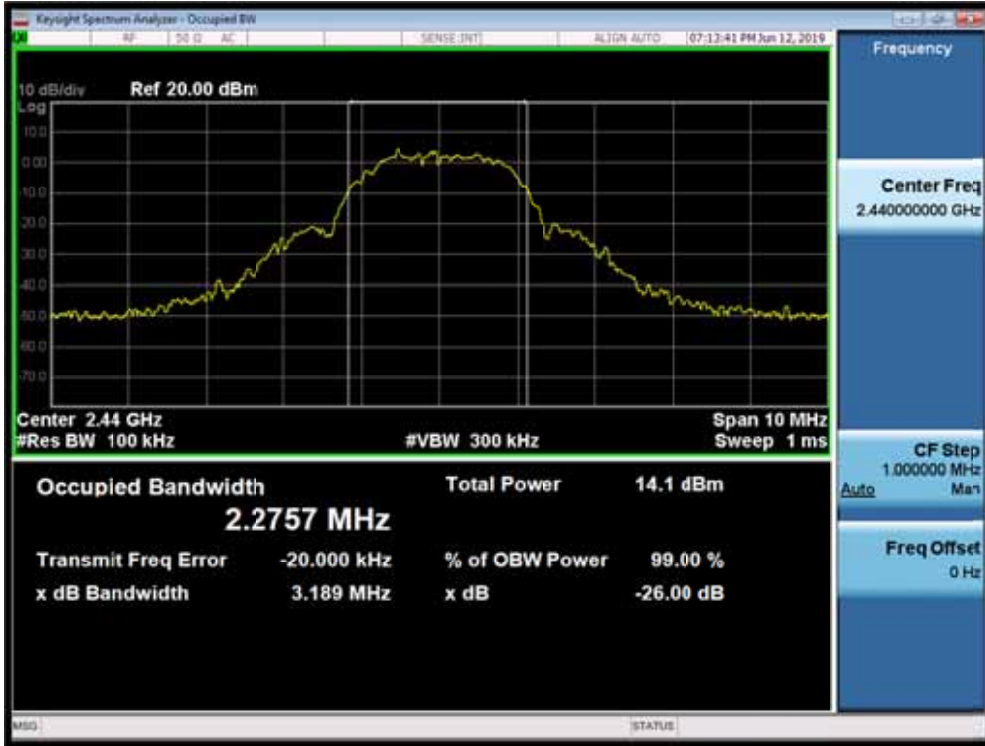

Mode 1 CH39 (2480MHz)

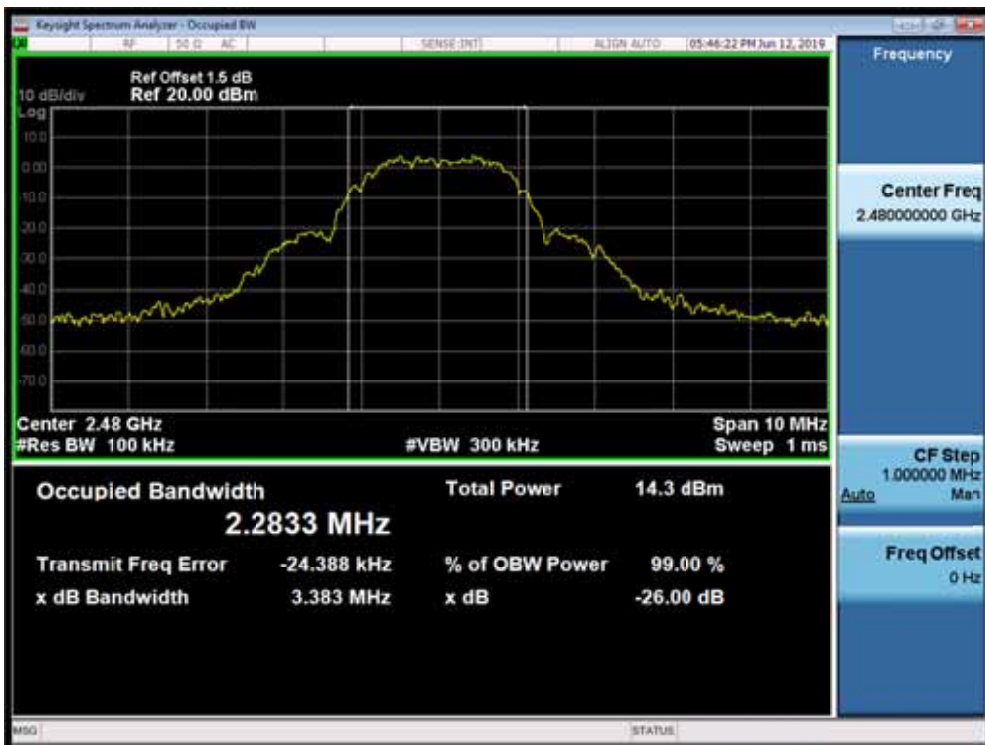

Mode	CH.	Test Freq. (MHz)	6dB Occupied Bandwidth (kHz)	Limit (kHz)	Result
1	11	2405	1722	>500	Pass
1	18	2440	1715	>500	Pass
1	26	2480	1683	>500	Pass

Note : The worst case of Occupied Bandwidth as below:

Mode 1 CH11 (2405MHz)



Mode 1 CH18 (2440MHz)



Mode 1 CH39 (2480MHz)



8. Fundamental emission output power

8.1. Test Equipment

Fundamental emission output power/ TR-8					
Instrument	Manufacturer	Type No.	Serial No.	Cal. Date	Cal. Due Date
Spectrum Analyzer	Agilent	E4446A	MY45300103	2019.01.04	2020.01.03
Spectrum Analyzer	Agilent	N9010A	MY48030494	2019.02.04	2020.01.15
Wideband Peak Power Meter	Anritsu	ML2495A	0905006	2018.10.14	2019.10.13
Power Sensor	Anritsu	MA2411B	0846014	2018.10.14	2019.10.13
Temperature/Humidity Meter	zhicheng	ZC1-2	TR8-TH	2018.04.10	2019.04.09

Note: All equipments are calibrated with traceable calibrations. Each calibration is traceable to the national or international standards.

8.2. Test Setup

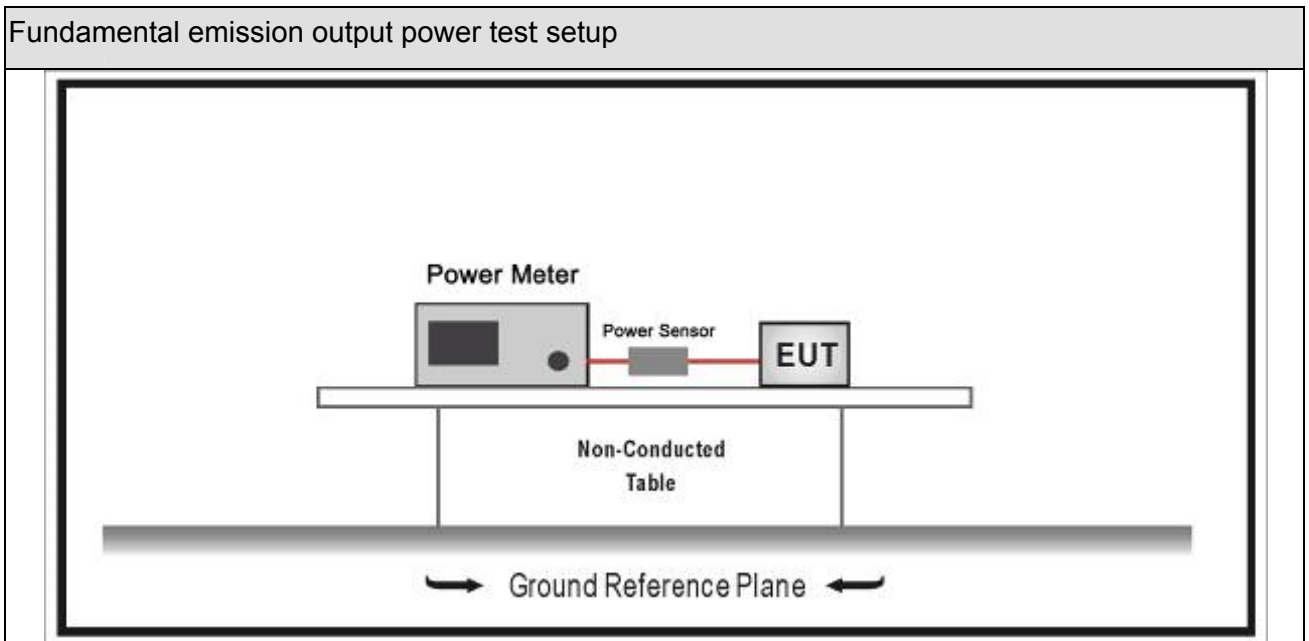





8.3. Limit

Fundamental emission output power Limit		
<input checked="" type="checkbox"/>	$G_{TX} < 6\text{dBi}$	$P_{out} \ 30\text{dBm}$
<input type="checkbox"/>	$G_{TX} > 6\text{dBi}$	
<input type="checkbox"/>	Non-Fix point-point	$P_{out} \ 30-(G_{TX}-6)$
<input type="checkbox"/>	Fix point-point	$P_{out} \ 30-[(G_{TX}-6)]/3$
<input type="checkbox"/>	Point-to-multipoint	$P_{out} \ 30-(G_{TX}-6)$
<input type="checkbox"/>	Overlap Beams	$P_{out} \ 30-[(G_{TX}-6)]/3$
<input type="checkbox"/>	Aggregate power transmitted simultaneously on all beams	$P_{out} \ 30-[(G_{TX}-6)]/3$
<input type="checkbox"/>	single directional beam	$P_{out} \ 30-[(G_{TX}-6)]/3+8\text{dB}$
<p>Note 1 : G_{TX} directional gain of transmitting antennas.</p> <p>Note 2 : P_{out} is maximum peak conducted output power .</p>		

8.4. Test Procedure

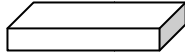
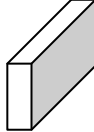
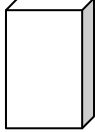
Fundamental emission output power Test Method					
	References Rule		Chapter	Description	
<input checked="" type="checkbox"/>	ANSI C63.10		11.9	Fundamental emission output power	
	<input checked="" type="checkbox"/>	ANSI C63.10		11.9.1	Maximum peak conducted output power
	<input type="checkbox"/>	ANSI C63.10	11.9.1.1	RBW ≥ DTS bandwidth	
	<input type="checkbox"/>	ANSI C63.10	11.9.1.2	Integrated band power method	
	<input checked="" type="checkbox"/>	ANSI C63.10	11.9.1.3	PKPM1 Peak power meter method	
	<input checked="" type="checkbox"/>	ANSI C63.10		11.9.2	Maximum conducted (average) output power
	<input type="checkbox"/>	ANSI C63.10		11.9.2.2	Measurement using a spectrum analyzer (SA)
	<input type="checkbox"/>	ANSI C63.10	11.9.2.2.2	Method AVGSA-1(Duty cycle 98%)	
	<input type="checkbox"/>	ANSI C63.10	11.9.2.2.3	Method AVGSA-1A(Duty cycle 98%)	
	<input type="checkbox"/>	ANSI C63.10	11.9.2.2.4	Method AVGSA-2(Duty cycle 98%)	
	<input type="checkbox"/>	ANSI C63.10	11.9.2.2.5	Method AVGSA-2A(Duty cycle 98%)	
	<input type="checkbox"/>	ANSI C63.10	11.9.2.2.4	Method AVGSA-3	
	<input type="checkbox"/>	ANSI C63.10	11.9.2.2.5	Method AVGSA-3A	
	<input checked="" type="checkbox"/>	ANSI C63.10		11.9.2.3	Measurement using a power meter (PM)
	<input checked="" type="checkbox"/>	ANSI C63.10	11.9.2.3.1	Method AVGPM	
<input type="checkbox"/>	ANSI C63.10	11.9.2.3.2	Method AVGPM-G		

8.5. EUT test definition

Item	Fundamental emission output power			
Device Category	<input type="checkbox"/>	Fixed point-to-point		
	<input type="checkbox"/>	Emit multiple directional beams, simultaneously or sequentially		
	<input checked="" type="checkbox"/>	Other cases		
Test mode	Mode 1			
Test method	<input type="checkbox"/>	Radiated		
		X Axis	Y Axis	Z Axis
				
		Worst Axis <input type="checkbox"/>	Worst Axis <input type="checkbox"/>	Worst Axis <input type="checkbox"/>
	<input checked="" type="checkbox"/>	Conducted		
	<input checked="" type="checkbox"/>	Chain 0		
				
	<input type="checkbox"/>	Chain 0	Chain 1	
				
	<input type="checkbox"/>	Chain 0	Chain 1	Chain 2
				

8.6. Test Result

Product Name	: LED lamp	Power	: AC 120V/60Hz
Test Mode	: Mode 1	Test Site	: TR-8
Test Date	: 2019.03.16		

Muruta:

Mode	Channel	Test Frequency (MHz)	Measurement Power Output (dBm)	Limit (dBm)	Result
1	11	2405	11.28	30	Pass
1	18	2440	11.73	30	Pass
1	26	2480	11.86	30	Pass

Diodes:

Mode	Channel	Test Frequency (MHz)	Measurement Power Output (dBm)	Limit (dBm)	Result
1	11	2405	11.49	30	Pass
1	18	2440	12.07	30	Pass
1	26	2480	13.04	30	Pass

Kdx:

Mode	Channel	Test Frequency (MHz)	Measurement Power Output (dBm)	Limit (dBm)	Result
1	11	2405	11.21	30	Pass
1	18	2440	11.51	30	Pass
1	26	2480	12.15	30	Pass

9. Power Spectral Density

9.1. Test Equipment

Power Spectral Density / TR-8					
Instrument	Manufacturer	Type No.	Serial No.	Cal. Date	Cal. Due Date
Spectrum Analyzer	Agilent	N9010A	MY48030494	2019.02.04	2020.02.03
EXA Spectrum Analyzer	Keysight	N9010A	MY55370495	2018.04.09	2019.04.08
MXA Signal Analyzer	Keysight	N9020A	MY56060147	2018.04.09	2019.04.08
Temperature/Humidity Meter	zhichen	ZC1-2	TR8-TH	2018.04.10	2019.04.09

Note: All equipments are calibrated with traceable calibrations. Each calibration is traceable to the national or international standards.

9.2. Test Setup

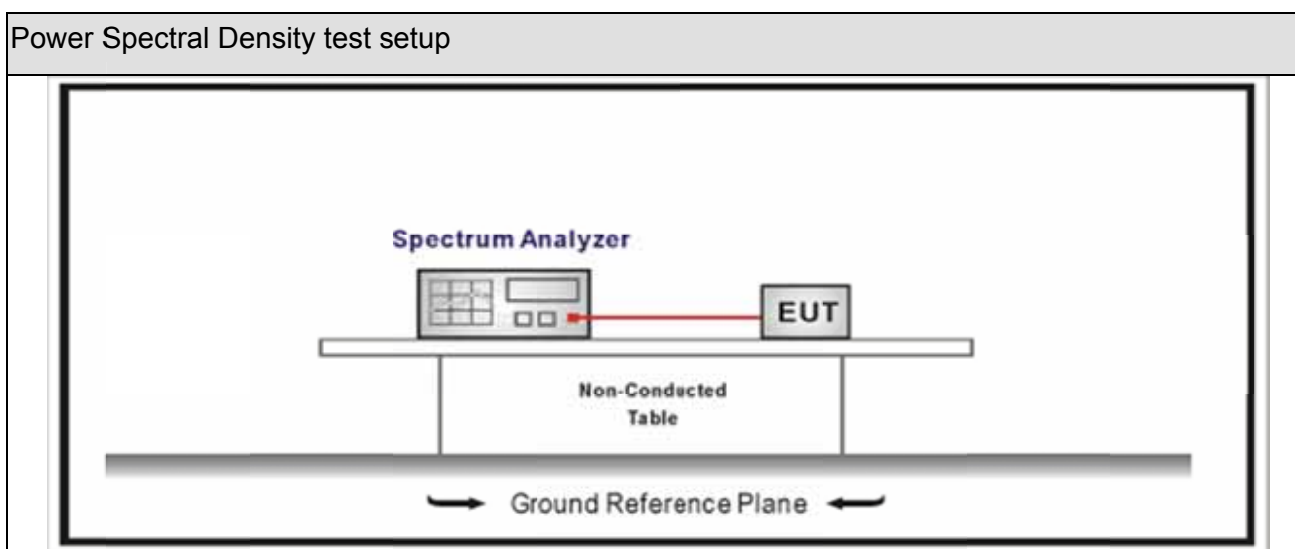



9.3. Limit

Power Spectral Density Limit
Power Spectral Density 8dBm/3kHz

9.4. Test Procedure

Power Spectral Density Test Method			
	References Rule	Chapter	Description
<input checked="" type="checkbox"/>	ANSI C63.10	11.10	Maximum power spectral density level in the fundamental emission
<input checked="" type="checkbox"/>	ANSI C63.10	11.10.2	Method PKPSD (peak PSD)
<input type="checkbox"/>	ANSI C63.10	11.10.3	Method AVGPSD-1(Duty cycle 98%)
<input type="checkbox"/>	ANSI C63.10	11.10.4	Method AVGPSD-1A(Duty cycle 98%)
<input type="checkbox"/>	ANSI C63.10	11.10.5	Method AVGPSD-2(Duty cycle < 98%)
<input type="checkbox"/>	ANSI C63.10	11.10.6	Method AVGPSD-2A(Duty cycle < 98%)
<input type="checkbox"/>	ANSI C63.10	11.10.7	Method AVGPSD-3
<input type="checkbox"/>	ANSI C63.10	11.10.8	Method AVGPSD-3A

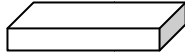
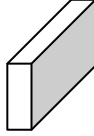
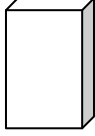
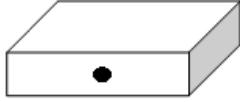
9.5. EUT test definition

Item	Power Spectral Density Test Method			
Device Category	<input type="checkbox"/>	Fixed point-to-point		
	<input type="checkbox"/>	Emit multiple directional beams, simultaneously or sequentially		
	<input checked="" type="checkbox"/>	Other cases		
Test mode	Mode 1			
Test method	<input type="checkbox"/>	Radiated		
		X Axis	Y Axis	Z Axis
				
		Worst Axis <input type="checkbox"/>	Worst Axis <input type="checkbox"/>	Worst Axis <input type="checkbox"/>
	<input checked="" type="checkbox"/>	Conducted		
	<input checked="" type="checkbox"/>	Chain 0		
				
	<input type="checkbox"/>	Chain 0	Chain 1	
				
	<input type="checkbox"/>	Chain 0	Chain 1	Chain 2
				

9.6. Test Result

Product Name	: LED lamp	Power	: AC 120V/60Hz
Test Mode	: Mode 1	Test Site	: TR-8
Test Date	: 2019.03.16		

Mode	Channel	Test Frequency (MHz)	Measurement PSD (dBm/3kHz)	Total PSD (dBm/3kHz)	Limit (dBm/3kHz)	Result
1	11	2405	-6.487	-6.487	8	Pass
1	18	2440	-5.297	-5.297	8	Pass
1	26	2480	-5.795	-5.795	8	Pass

Note : The worst case of Power Spectral Density as below:

Mode 1 CH18(2440MHz)



10. Antenna Requirement

10.1. Limit

Antenna Requirement Limit	
<p>An intentional radiator shall be designed to ensure that no antenna other than that furnished by the responsible party shall be used with the device. The use of a permanently attached antenna or of an antenna that uses a unique coupling to the intentional radiator shall be considered sufficient to comply with the provisions of this section. The manufacturer may design the unit so that a broken antenna can be replaced by the user, but the use of a standard antenna jack or electrical connector is prohibited. This requirement does not apply to carrier current devices or to devices operated under the provisions of §15.211, §15.213, §15.217, §15.219, or §15.221. Further, this requirement does not apply to intentional radiators that must be professionally installed, such as perimeter protection systems and some field disturbance sensors, or to other intentional radiators which, in accordance with §15.31(d), must be measured at the installation site. However, the installer shall be responsible for ensuring that the proper antenna is employed so that the limits in this part are not exceeded.</p>	

10.2. Antenna Connector Construction

Antenna Connector Construction	
<input checked="" type="checkbox"/>	The use of a permanently attached antenna
<input type="checkbox"/>	The antenna use of a unique coupling to the intentional radiator
<input type="checkbox"/>	The use of a nonstandard antenna jack or electrical connector
Please refer to the attached document "Internal Photograph" to show the antenna connector.	

_____ The End _____