



Test Report

FCC Part15 Subpart C

Product Name : LED lamp
Model No. : 9290018194
FCC ID : 2AGBW9290018194X

Applicant : Signify (China) Investment Co., Ltd.
Address : Building no.9, Lane 888, Tianlin Road, Minhang District,
Shanghai 200233, China

Date of Receipt : Mar. 07, 2019
Issued Date : Mar. 08, 2019
Report No. : 1932078R-RF-US-P06V01
Report Version : V1.0

Note: This report was based on DEKRA Report No. 1882181R-RF-US-P06V01, only updated Product Name, and Address.

The test results relate only to the samples tested.

The test results shown in the test report are traceable to the national/international standard through the calibration of the equipment and evaluated measurement uncertainty herein.

This report must not be used to claim product endorsement by A2LA, TAF or any agency of the government.

The test report shall not be reproduced without the written approval of DEKRA Testing & Certification (Suzhou) Co., Ltd.

Test Report Certification

Issued Date : Mar. 08, 2019
Report No. : 1932078R-RF-US-P06V01



Product Name : LED lamp
 Applicant : Signify (China) Investment Co., Ltd.
 Address : Building no.9, Lane 888, Tianlin Road, Minhang District, Shanghai 200233, China
 Manufacturer : Signify (China) Investment Co., Ltd.
 Address : Building no.9, Lane 888, Tianlin Road, Minhang District, Shanghai 200233, China
 Model No. : 9290018194
 FCC ID : 2AGBW9290018194X
 EUT Voltage : 110 – 130Vac, 9W, 50-60Hz
 Test Voltage : AC 120V/60Hz
 Brand Name : Philips
 Applicable Standard : FCC CFR Title 47 Part 15 Subpart C: 2017
 ANSI C63.4:2014; ANSI C63.10:2013;
 KDB 558074 D01v05
 Test Result : Complied
 Performed Location : DEKRA Testing and Certification (Suzhou) Co., Ltd.
 No.99 Hongye Rd., Suzhou Industrial Park, Suzhou, 215006,
 Jiangsu, China
 TEL: +86-512-6251-5088 / FAX: +86-512-6251-5098
 FCC Designation Number: CN1199

Documented By : Kitty Li
 (Adm. Specialist: Kitty Li)

Reviewed By : Frank He
 (Senior Project Manager: Frank He)

Approved By : Jack Zhang
 (Engineering Supervisor: Jack Zhang)

TABLE OF CONTENTS

Description	Page
1. General Information.....	6
1.1. EUT Description	6
1.2. Working Frequency of Each Channel:	7
1.3. Antenna information	7
1.4. Mode of Operation.....	8
1.5. Tested System Details	8
1.6. Configuration of Tested System.....	9
1.7. EUT Exercise Software.....	10
2. Technical Test.....	11
2.1. Summary of Test Result.....	11
2.2. Test Environment.....	12
2.3. Measurement Uncertainty	12
3. AC Power Line Conducted Emission	13
3.1. Test Equipment.....	13
3.2. Test Setup.....	13
3.3. Limit.....	14
3.4. Test Procedure	14
3.5. Test Result.....	15
4. Emissions in restricted frequency bands	17
4.1. Test Equipment.....	17
4.2. Test Setup.....	18
4.3. Limit.....	19
4.4. Test Procedure	21
4.5. EUT test Axis definition.....	22
4.6. Test Result.....	23
5. Emissions in non-restricted frequency bands	37
5.1. Test Equipment.....	37
5.2. Test Setup.....	37
5.3. Limit.....	38
5.4. Test Procedure	39
5.5. EUT test Axis definition.....	40
5.6. Test Result.....	41
6. Radiated Emission Band Edge	42
6.1. Test Equipment.....	42
6.2. Test Setup.....	43
6.3. Limit.....	43
6.4. Test Procedure	44

- 6.5. EUT test definition45
- 6.6. Duty Cycle46
- 6.7. Test Result47
- 7. Occupied Bandwidth63
- 7.1. Test Equipment.....63
- 7.2. Test Setup.....63
- 7.3. Limit.....64
- 7.4. Test Procedure64
- 7.5. EUT test definition65
- 7.6. Test Result.....66
- 8. Fundamental emission output power67
- 8.1. Test Equipment.....67
- 8.2. Test Setup.....67
- 8.3. Limit.....68
- 8.4. Test Procedure69
- 8.5. EUT test definition70
- 8.6. Test Result.....71
- 9. Power Spectral Density72
- 9.1. Test Equipment.....72
- 9.2. Test Setup.....72
- 9.3. Limit.....72
- 9.4. Test Procedure73
- 9.5. EUT test definition74
- 9.6. Test Result.....75
- 10. Antenna Requirement.....76
- 10.1. Limit.....76
- 10.2. Antenna Connector Construction.....76

History of This Test Report

REPORT NO.	VERSION	DESCRIPTION	ISSUED DATE
1932078R-RF-US-P06V01	V1.0	Initial Issued Report	Mar. 08, 2019

1. General Information

1.1. EUT Description

Product Name	LED lamp
Model No.	9290018194
EUT Voltage	110 – 130Vac,9W, 50-60Hz
Test Voltage	AC 120V/60Hz
Zigbee	
Frequency Range	2405 ~ 2480MHz
Channel Number	16
Type of Modulation	DSSS-OQPSK
Data Rate	250kbps
Antenna Type	Reference to Antenna List

Note: For EUT with “ Diode” crystal oscillators, all test has been done. For EUT with “ Murata” crystal oscillators, Only RF output power, radiated spurious emission and band edge were shown in the report.

1.2. Working Frequency of Each Channel:

Zigbee Working Frequency of Each Channel:							
Channel	Frequency	Channel	Frequency	Channel	Frequency	Channel	Frequency
11	2405 MHz	12	2410 MHz	13	2415 MHz	14	2420 MHz
15	2425 MHz	16	2430 MHz	17	2435 MHz	18	2440 MHz
19	2445 MHz	20	2450 MHz	21	2455 MHz	22	2460 MHz
23	2465 MHz	24	2470 MHz	25	2475 MHz	26	2480 MHz

1.3. Antenna information

Antenna manufacturer	N/A						
Antenna Delivery	<input checked="" type="checkbox"/>	1*TX+1*RX	<input type="checkbox"/>	2*TX+2*RX	<input type="checkbox"/>	3*TX+3*RX	
Antenna technology	<input checked="" type="checkbox"/>	SISO					
	<input type="checkbox"/>	MIMO	<input type="checkbox"/>	Basic			
			<input type="checkbox"/>	CDD			
			<input type="checkbox"/>	Beam-forming			
Antenna Type	<input type="checkbox"/>	External	<input type="checkbox"/>	Dipole			
	<input checked="" type="checkbox"/>	Internal	<input type="checkbox"/>	PIFA			
			<input checked="" type="checkbox"/>	PCB			
			<input type="checkbox"/>	Ceramic Chip Antenna			
			<input type="checkbox"/>	Metal plate type F antenna			
Antenna Gain	3.5dBi						

1.4. Mode of Operation

Test Mode
Mode 1: Transmit

1.5. Tested System Details

The types for all equipments, plus descriptions of all cables used in the tested system (including inserted cards) are:

No.	Product	Manufacturer	Model No.	Serial No.	Power Cord
1	Notebook	Think Pad	2526	LV-A3285	Power by adapter
A	USB Control Cable	N/A	N/A	N/A	Shield, 1m
B	USB Control Cable	N/A	N/A	N/A	Shield, 10m

1.6. Configuration of Tested System

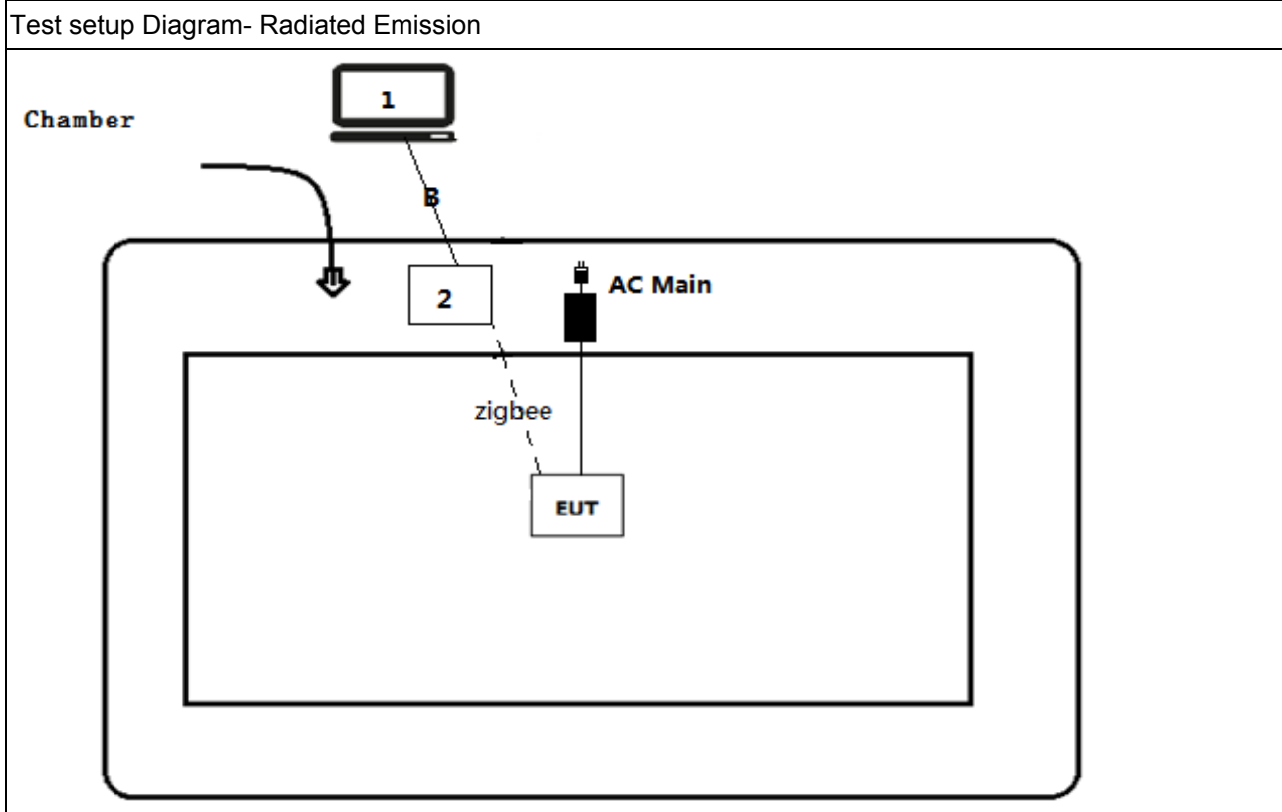
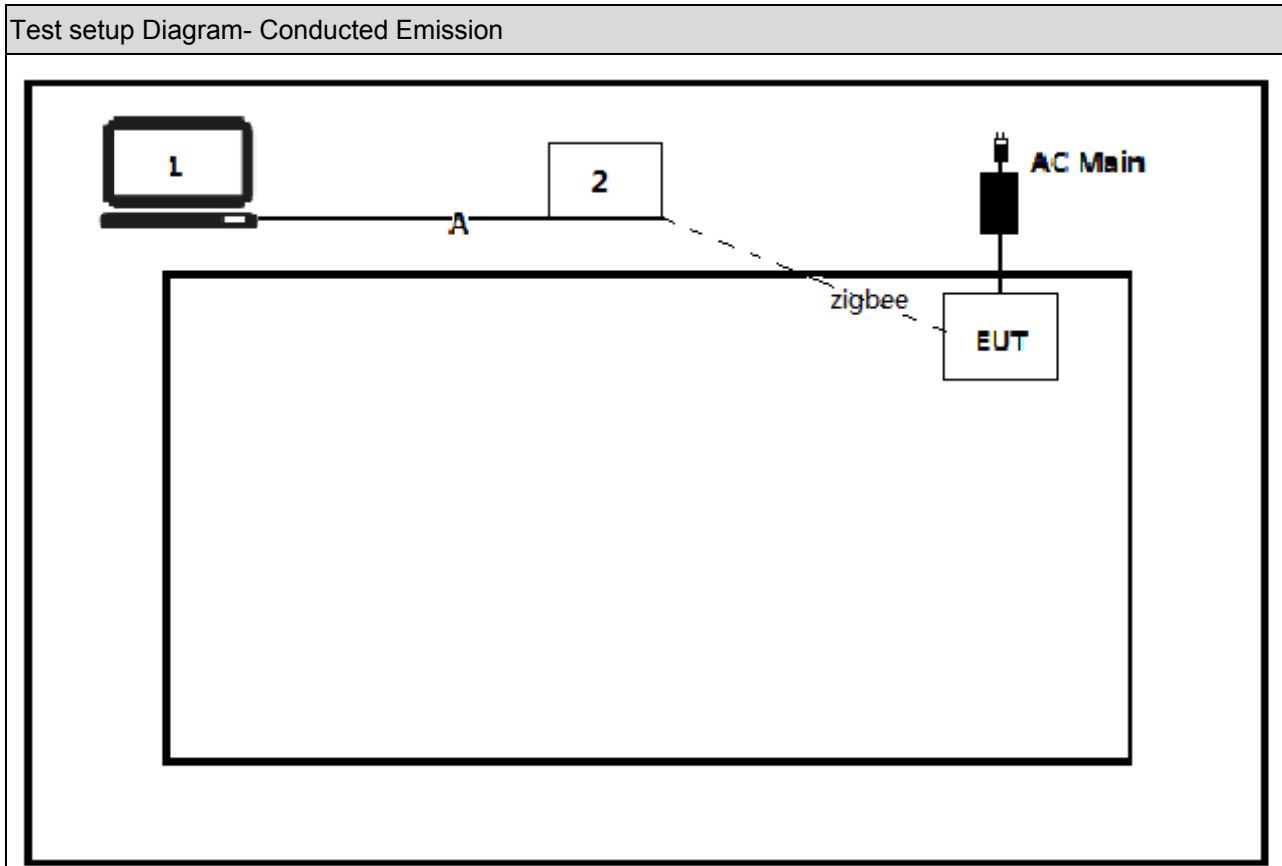

1.7. EUT Exercise Software

1	Setup the EUT and simulators as shown on above.
2	Turn on the power of equipment.
3	Run the test software (HueApprobation Tool).
4	Select the transmission mode and test channel, then start test.

2. Technical Test

2.1. Summary of Test Result

Performed Test Item	Normative References	Worst case mode	Limit	Result
AC Power Line Conducted Emission	FCC CFR Title 47 Part 15 Subpart C: 2015 Section 15.207	Mode 1	FCC 15.207	PASS
Emissions in restricted frequency bands	FCC CFR Title 47 Part 15 Subpart C: 2015 Section 15.209	Mode 1	FCC 15.209	PASS
Emissions in non-restricted frequency bands	FCC CFR Title 47 Part 15 Subpart C: 2015 Section 15.247(d)	Mode 1	20dBc	PASS
Radiated Emission Band Edge	FCC CFR Title 47 Part 15 Subpart C: 2015 15.247(d)	Mode 1	FCC 15.209	PASS
Occupied Bandwidth	FCC CFR Title 47 Part 15 Subpart C: 2015 Section 15.247(a)(2)	Mode 1	500kHz	PASS
Fundamental emission output power	FCC CFR Title 47 Part 15 Subpart C: 2015 Section 15.247(b)(3)	Mode 1	30dBm	PASS
Power Spectral Density	FCC CFR Title 47 Part 15 Subpart C: 2015 Section 15.247(e)	Mode 1	8dBm/3kHz	PASS
Antenna Requirement	FCC CFR Title 47 Part 15 Subpart C: 2015 Section 15.203	N/A	FCC 15.203	PASS

2.2. Test Environment

Items	Required (IEC 68-1)	Actual
Temperature (°C)	15-35	21
Humidity (%RH)	25-75	50
Barometric pressure (mbar)	860-1060	950-1000

2.3. Measurement Uncertainty

Test Items	Uncertainty
AC Power Line Conducted Emission	$\pm 2.02\text{dB}$
Radiated Emission	Below 1GHz $\pm 3.8\text{ dB}$
	Above 1GHz $\pm 3.9\text{ dB}$
RF Antenna Port Conducted Emission	$\pm 1.27\text{dB}$
Radiated Emission Band Edge	$\pm 3.9\text{dB}$
Occupied Bandwidth	$\pm 1\text{kHz}$
Power Spectral Density	$\pm 1.27\text{dB}$

3. AC Power Line Conducted Emission

3.1. Test Equipment

AC Power Line Conducted Emission / TR-1					
Instrument	Manufacturer	Type No.	Serial No.	Cal. Date	Cal. Due Date
EMI Test Receiver	R&S	ESCI	100906	2018.03.05	2019.03.04
Two-Line V-Network	R&S	ENV 216	101189	2018.07.16	2019.07.15
Two-Line V-Network	R&S	ENV 216	101044	2018.09.16	2019.09.15
50ohm Coaxial Switch	Anritsu	MP59B	6200464462	N/A	N/A
50ohm Termination	SHX	TF2	07081402	2018.09.16	2019.09.15
Temperature/Humidity Meter	Zhichen	ZC1-2	TR1-TH	2018.01.05	2019.01.04

Note: All equipments are calibrated with traceable calibrations. Each calibration is traceable to the national or international standards.

3.2. Test Setup

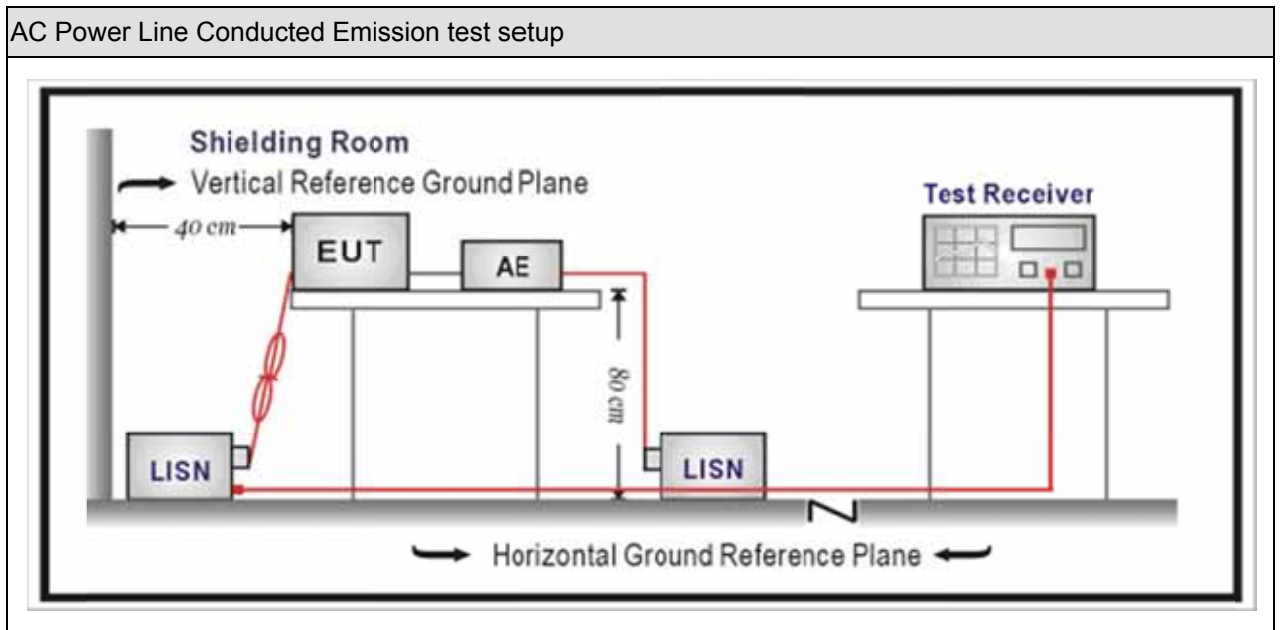

3.3. Limit

Frequency of Emission (MHz)	Conducted Limit	
	Quasi-peak (dB μ V)	Average (dB μ V)
0.15-0.5	66 to 56	56 to 46
0.5-5	56	46
5-30	60	50

Note 1: The lower limit shall apply at the transition frequencies.
 Note 2: The limit decreases linearly with the logarithm of the frequency in the range 0.15 MHz to 0.5 MHz.

3.4. Test Procedure

Test Method			
	References Rule	Chapter	Item
<input checked="" type="checkbox"/>	ANSI C63.10-2013	6.2	Standard test method for ac power-line conducted emissions from unlicensed wireless devices
<input checked="" type="checkbox"/>	ANSI C63.4-2014	7	AC power-line conducted emission measurements

3.5. Test Result

Site: TR1	Time: 2018/09/14
Limit: FCC_Part15.107_CE_AC Power_ClassB	Margin: 0
Probe: ENV216_101190(0.009-30MHz)	Polarity: Line
EUT: LED lamp	Power: AC 120V/60Hz
Note: Mode1: Transmit at 2405MHz by Zigbee	

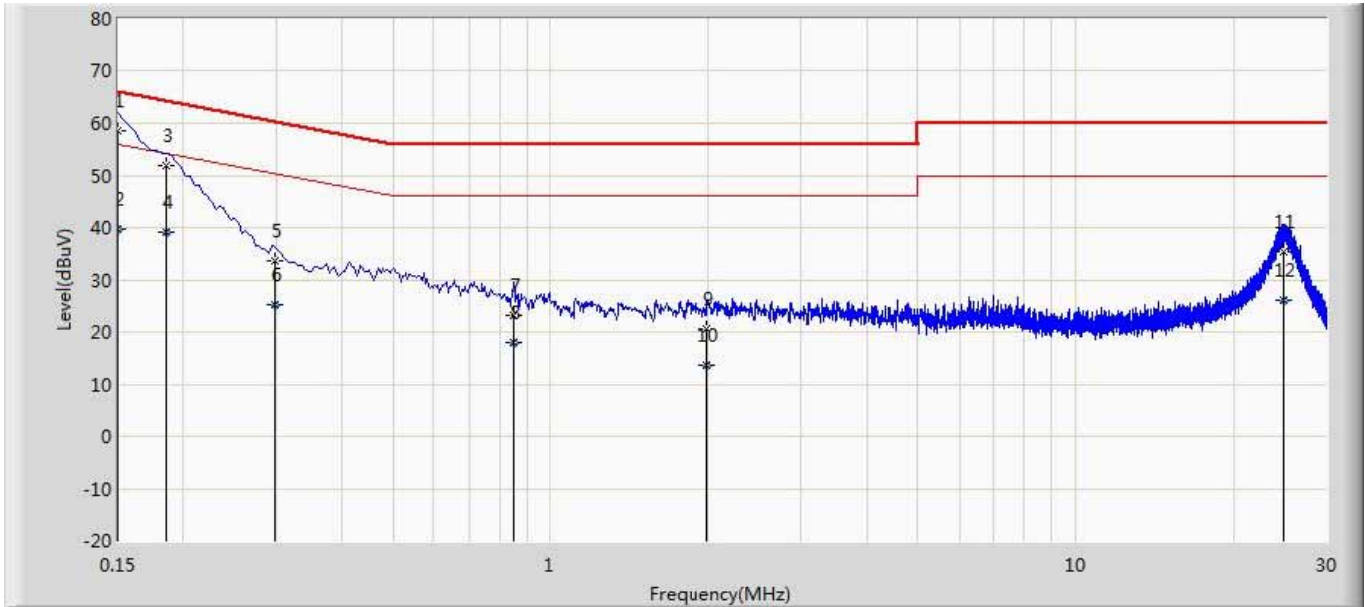

No	Mark	Frequency (MHz)	Measure Level (dBuV)	Reading Level (dBuV)	Over Limit (dB)	Limit (dBuV)	Probe (dB)	Cable (dB)	Amp (dB)	Type
1	*	0.150	58.673	49.039	-7.327	66.000	9.610	0.025	0.000	QP
2		0.150	39.601	29.966	-16.399	56.000	9.610	0.025	0.000	AV
3		0.186	51.889	42.258	-13.083	64.971	9.603	0.028	0.000	QP
4		0.186	39.012	29.381	-15.960	54.971	9.603	0.028	0.000	AV
5		0.298	33.585	23.951	-28.186	61.771	9.600	0.034	0.000	QP
6		0.298	25.110	15.476	-26.661	51.771	9.600	0.034	0.000	AV
7		0.850	23.312	13.653	-32.688	56.000	9.605	0.054	0.000	QP
8		0.850	18.022	8.363	-27.978	46.000	9.605	0.054	0.000	AV
9		1.986	20.503	10.806	-35.497	56.000	9.610	0.087	0.000	QP
10		1.986	13.523	3.826	-32.477	46.000	9.610	0.087	0.000	AV
11		24.934	35.311	24.522	-24.689	60.000	10.465	0.323	0.000	QP
12		24.934	25.990	15.201	-24.010	50.000	10.465	0.323	0.000	AV

Note:

1. " * ", means this data is the worst emission level.
2. Measurement Level = Reading Level + Factor(Probe+Cable-Amp).

Site: TR1	Time: 2018/09/14
Limit: FCC_Part15.107_CE_AC Power_ClassB	Margin: 0
Probe: ENV216_101190(0.009-30MHz)	Polarity: Neutral
EUT: LED lamp	Power: AC 120V/60Hz
Note: Mode1: Transmit at 2405MHz by Zigbee	

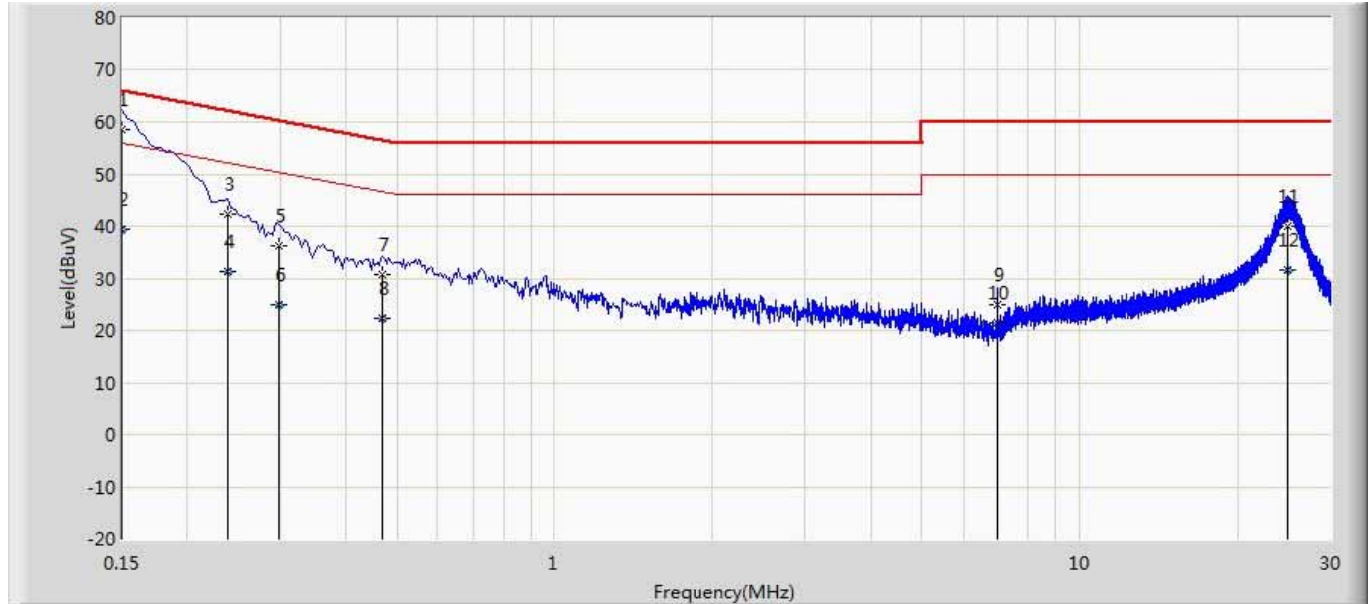

No	Mark	Frequency (MHz)	Measure Level (dBuV)	Reading Level (dBuV)	Over Limit (dB)	Limit (dBuV)	Probe (dB)	Cable (dB)	Amp (dB)	Type
1	*	0.150	58.550	48.931	-7.450	66.000	9.594	0.025	0.000	QP
2		0.150	39.421	29.802	-16.579	56.000	9.594	0.025	0.000	AV
3		0.238	42.265	32.636	-21.221	63.486	9.598	0.030	0.000	QP
4		0.238	31.187	21.559	-22.299	53.486	9.598	0.030	0.000	AV
5		0.298	36.202	26.572	-25.569	61.771	9.596	0.034	0.000	QP
6		0.298	24.791	15.160	-26.981	51.771	9.596	0.034	0.000	AV
7		0.470	30.696	21.064	-26.162	56.857	9.591	0.041	0.000	QP
8		0.470	22.387	12.756	-24.470	46.857	9.591	0.041	0.000	AV
9		6.994	25.064	15.196	-34.936	60.000	9.700	0.168	0.000	QP
10		6.994	21.353	11.485	-28.647	50.000	9.700	0.168	0.000	AV
11		24.902	39.892	28.918	-20.108	60.000	10.651	0.323	0.000	QP
12		24.902	31.624	20.650	-18.376	50.000	10.651	0.323	0.000	AV

Note:

1. " * ", means this data is the worst emission level.
2. Measurement Level = Reading Level + Factor(Probe+Cable+Amp).

4. Emissions in restricted frequency bands

4.1. Test Equipment

Radiated Emission(Below 1GHz) / AC-2					
Instrument	Manufacturer	Type No.	Serial No.	Cal. Date	Cal. Due Date
EMI Test Receiver	R&S	ESCI	100573	2018.03.29	2019.03.28
Loop Antenna	R&S	HFH2-Z2	833799/003	2017.11.16	2018.11.15
Bilog Antenna	Teseq GmbH	CBL6112D	27611	2018.10.16	2019.10.15
Coaxial Cable	Huber+Suhner	SUCOFLEX 106	AC2-C	2018.03.02	2019.03.01
Temperature/Humidity Meter	Zhichen	ZC1-2	AC2-TH	2018.01.04	2019.01.03
Note: All equipments are calibrated with traceable calibrations. Each calibration is traceable to the national or international standards.					

Radiated Emission(Above 1GHz) / AC-5					
Instrument	Manufacturer	Type No.	Serial No.	Cal. Date	Cal. Due Date
Spectrum Analyzer	Agilent	E4446A	MY45300103	2018.01.04	2019.01.03
Preamplifier	Miteq	NSP1800-25	1364185	2018.05.06	2019.05.05
Preamplifier	QuieTek	AP-040G	CHM-0906001	2018.05.06	2019.05.05
DRG Horn	ETS-Lindgren	3117	00123988	2018.01.22	2019.01.21
Broad-Band Horn Antenna	Schwarzbeck	BBHA9170	294	2017.11.25	2018.11.24
Coaxial Cable	Huber+Suhner	SUCOFLEX 106	AC5-C1	2018.03.02	2019.03.01
Coaxial Cable	Huber+Suhner	SUCOFLEX 106	AC5-C2	2018.03.02	2019.03.01
Coaxial Cable	Huber+Suhner	SUCOFLEX 102	AC5-C3	2018.03.02	2019.03.01
EMI Receiver	Agilent	N9038A	MY51210196	2018.06.10	2019.06.09
Temperature/Humidity Meter	Zhichen	ZC1-2	AC5-TH	2018.01.04	2019.01.03
Note: All equipments are calibrated with traceable calibrations. Each calibration is traceable to the national or international standards.					

4.2. Test Setup

Below 30MHz Test Setup:

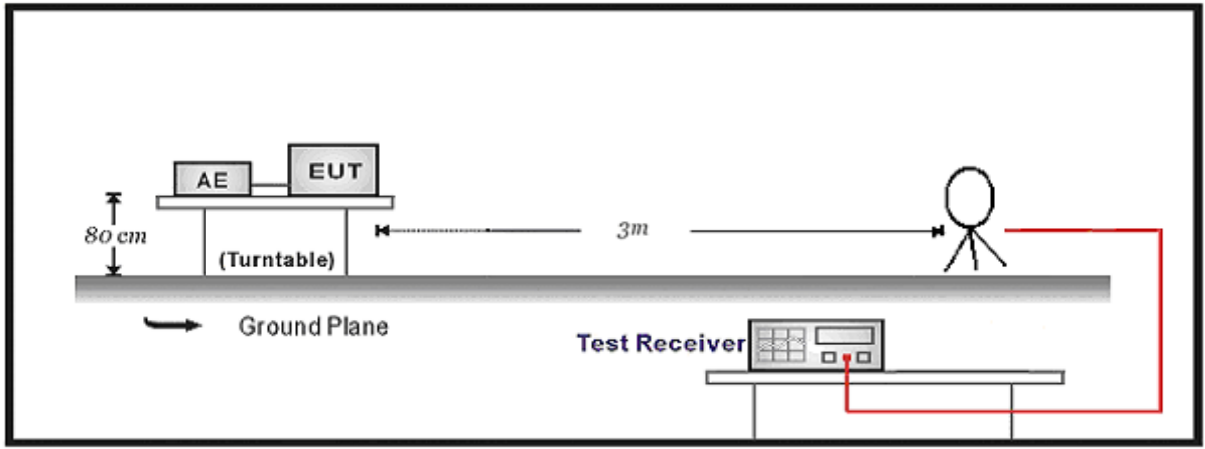

30MHz-1GHz Test Setup:

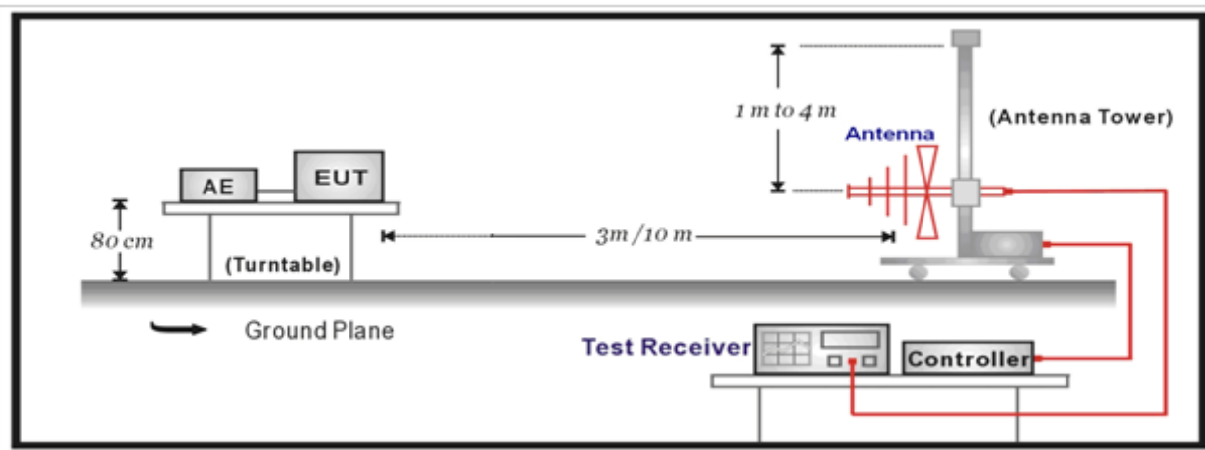

Above 1GHz Test Setup:

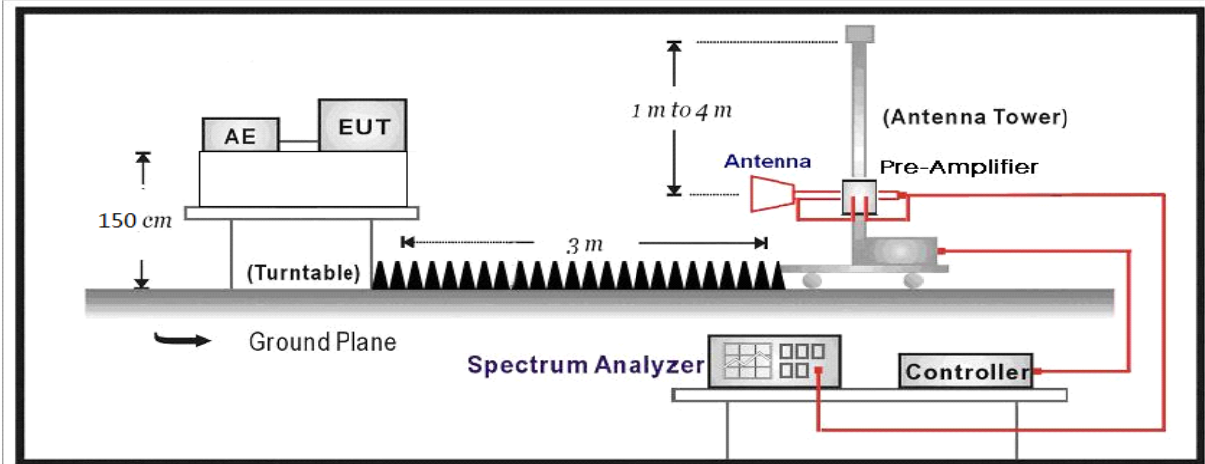

4.3. Limit

Restricted Bands of operation			
Frequency (MHz)	Frequency (MHz)	Frequency (MHz)	Frequency (GHz)
0.090 – 0.110	16.42 – 16.423	399.9 – 410	4.5 – 5.15
0.495 – 0.505	16.69475 – 16.69525	608 – 614	5.35 – 5.46
2.1735 – 2.1905	16.80425 – 16.80475	960 – 1240	7.25 – 7.75
4.125 – 4.128	25.5 – 25.67	1300 – 1427	8.025 – 8.5
4.17725 – 4.17775	37.5 – 38.25	1435 – 1626.5	9.0 – 9.2
4.20725 – 4.20775	73 – 74.6	1645.5 – 1646.5	9.3 – 9.5
6.215 – 6.218	74.8 – 75.2	1660 – 1710	10.6 – 12.7
6.26775 – 6.26825	108 – 121.94	1718.8 – 1722.2	13.25 – 13.4
6.31175 – 6.31225	123 – 138	2200 – 2300	14.47 – 14.5
8.291 – 8.294	149.9 – 150.05	2310 – 2390	15.35 – 16.2
8.362 – 8.366	156.52475 – 156.52525	2483.5 – 2500	17.7 – 21.4
8.37625 – 8.38675	156.7 – 156.9	2690 – 2900	22.01 – 23.12
8.81425 – 8.81475	162.0125 – 167.17	3260 – 3267	23.6 – 24.0
12.29 – 12.293	167.72 – 173.2	3332 – 3339	31.2 – 31.8
12.51975 – 12.52025	240 – 285	3345.8 – 3358	36.43 – 36.5
12.57675 – 12.57725	322 – 335.4	3600 – 4400	
13.36 – 13.41			

Restricted Band Emissions Limit			
Frequency (MHz)	Field strength (μ V/m)	Field strength (dB μ V/m)	Measurement distance (m)
0.009 - 0.49	2400/F(kHz)	48.5 – 13.8	300 _(Note 1)
0.49 - 1.705	24000/F(kHz)	33.8 - 23	30 _(Note 1)
1.705 - 30	30	29.5	30 _(Note 1)
30 - 88	100	40	3 _(Note 2)
88 - 216	150	43.5	3 _(Note 2)
216 - 960	200	46	3 _(Note 2)
Above 960	500	54	3 _(Note 2)



Note 1: At frequencies below 30 MHz, measurements may be performed at a distance closer than that specified in the regulations; however, an attempt should be made to avoid making measurements in the near field. Pending the development of an appropriate measurement procedure for measurements performed below 30 MHz, when performing measurements at a closer distance than specified, the results shall be extrapolated to the specified distance by either making measurements at a minimum of two distances on at least one radial to determine the proper extrapolation factor or by using the square of an inverse linear distance extrapolation factor (40 dB/decade).

Note 2: At frequencies at or above 30 MHz, measurements may be performed at a distance other than what is specified provided: measurements are not made in the near field except where it can be shown that near field measurements are appropriate due to the characteristics of the device; and it can be demonstrated that the signal levels needed to be measured at the distance employed can be detected by the measurement equipment. Measurements shall not be performed at a distance greater than 30 meters unless it can be further demonstrated that measurements at a distance of 30 meters or less are impractical. When performing measurements at a distance other than that specified, the results shall be extrapolated to the specified distance using an extrapolation factor of 20 dB/decade (inverse linear-distance for field strength measurements; inverse-linear-distance-squared for power density measurements).

4.4. Test Procedure

Test Method			
	References Rule	Chapter	Description
<input type="checkbox"/>	ANSI C63.10	11.11	Emissions in non-restricted frequency bands
	<input type="checkbox"/> ANSI C63.10	11.11.2	Reference level measurement
	<input type="checkbox"/> ANSI C63.10	11.11.3	Emission level measurement
<input checked="" type="checkbox"/>	ANSI C63.10	11.12	Emissions in restricted frequency bands
	<input checked="" type="checkbox"/> ANSI C63.10	11.12.1	Radiated emission measurements
	<input checked="" type="checkbox"/> ANSI C63.10	11.12.2.7	Radiated spurious emission test
	<input checked="" type="checkbox"/> ANSI C63.10	6.4	Radiated emissions from unlicensed wireless devices below 30 MHz
	<input checked="" type="checkbox"/> ANSI C63.10	6.5	Radiated emissions from unlicensed wireless devices in the frequency range of 30 MHz to 1000 MHz
	<input checked="" type="checkbox"/> ANSI C63.10	6.6	Radiated emissions from unlicensed wireless devices above 1 GHz
	<input type="checkbox"/> ANSI C63.10	11.12.2.3	Quasi-peak measurement procedure
	<input type="checkbox"/> ANSI C63.10	11.12.2.4	Peak power measurement procedure
	<input type="checkbox"/> ANSI C63.10	11.12.2.5	Average power measurement procedures
	<input type="checkbox"/> ANSI C63.10	11.12.2.5.1	Trace averaging with continuous EUT transmission at full power
	<input type="checkbox"/> ANSI C63.10	11.12.2.5.2	Trace averaging across ON and OFF times of the EUT transmissions followed by duty cycle correction
	<input type="checkbox"/> ANSI C63.10	11.12.2.5.3	Reduced VBW averaging across ON and OFF times of the EUT transmissions with max hold

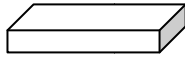
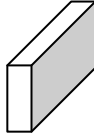
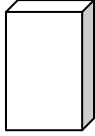
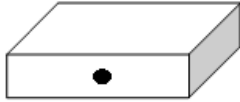
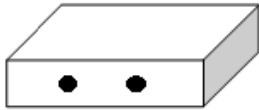
4.5. EUT test Axis definition

Item	Emissions in restricted frequency bands			
Device Category	<input type="checkbox"/>	Fixed point-to-point		
	<input type="checkbox"/>	Emit multiple directional beams, simultaneously or sequentially		
	<input checked="" type="checkbox"/>	Other cases		
Test mode	Mode 1			
Test method	<input checked="" type="checkbox"/>	Radiated		
		X Axis	Y Axis	Z Axis
				
		Worst Axis <input checked="" type="checkbox"/>	Worst Axis <input type="checkbox"/>	Worst Axis <input type="checkbox"/>
	<input type="checkbox"/>	Conducted		
	<input type="checkbox"/>	Chain 0		
				
	<input type="checkbox"/>	Chain 0	Chain 1	
				
	<input type="checkbox"/>	Chain 0	Chain 1	Chain 2
				

4.6. Test Result

Diode (FL3840023)_2017:

Engineer: ALLEN	
Site: AC5	Time: 2018/10/18 - 11:26
Limit: FCC_Part15.209_RE(3m)	Margin: 0
Probe: Horn_3117_00167055(1-18GHz)	Polarity: Horizontal
EUT: Lux BR30	Power: AC 120V/60Hz
Note: Mode 1:Transmit at 2405MHz by Zigbee	

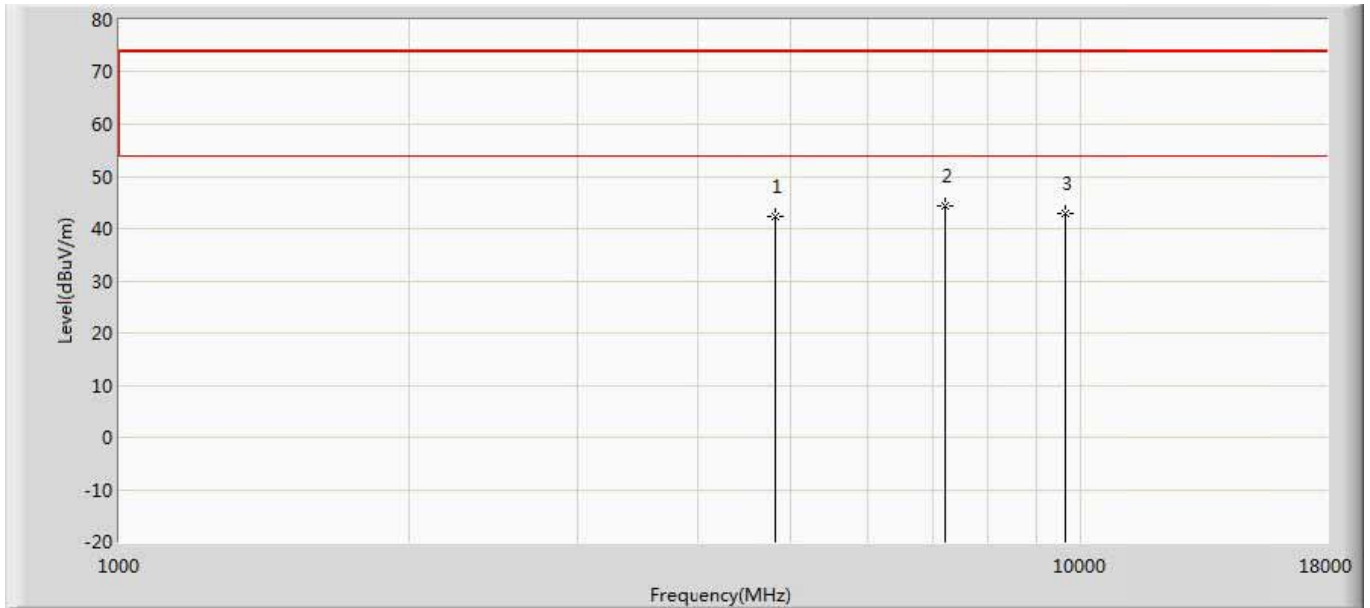

No	Mark	Frequency (MHz)	Measure Level (dBuV/m)	Reading Level (dBuV)	Over Limit (dB)	Limit (dBuV/m)	Factor (dB)	Type
1		4810.000	42.179	43.946	-31.821	74.000	-1.768	PK
2	*	7215.000	44.279	42.513	-29.721	74.000	1.766	PK
3		9620.000	42.822	38.714	-31.178	74.000	4.108	PK

Engineer: ALLEN	
Site: AC5	Time: 2018/10/18 - 11:26
Limit: FCC_Part15.209_RE(3m)	Margin: 0
Probe: Horn_3117_00167055(1-18GHz)	Polarity: Vertical
EUT: Lux BR30	Power: AC 120V/60Hz
Note: Mode 1:Transmit at 2405MHz by Zigbee	

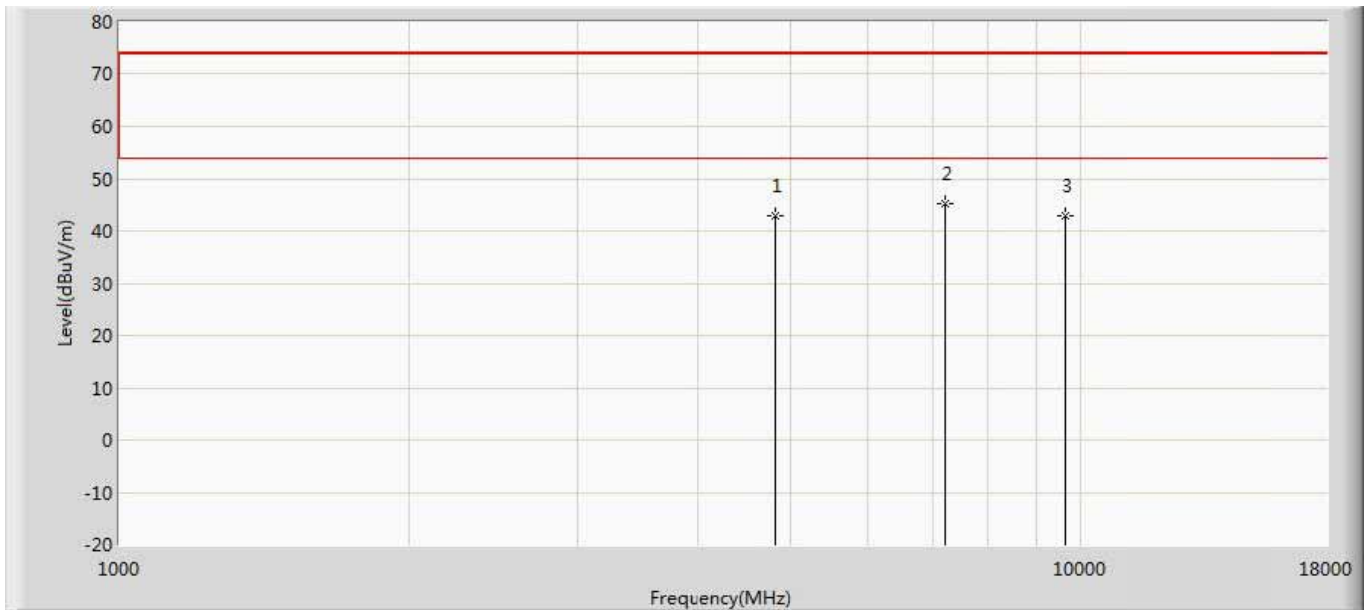

No	Mark	Frequency (MHz)	Measure Level (dBuV/m)	Reading Level (dBuV)	Over Limit (dB)	Limit (dBuV/m)	Factor (dB)	Type
1		4810.000	42.908	44.675	-31.092	74.000	-1.768	PK
2	*	7215.000	45.250	43.484	-28.750	74.000	1.766	PK
3		9620.000	42.895	38.787	-31.105	74.000	4.108	PK

Engineer: ALLEN	
Site: AC5	Time: 2018/10/18 - 11:26
Limit: FCC_Part15.209_RE(3m)	Margin: 0
Probe: Horn_3117_00167055(1-18GHz)	Polarity: Horizontal
EUT: Lux BR30	Power: AC 120V/60Hz
Note: Mode 1:Transmit at 2450MHz by Zigbee	

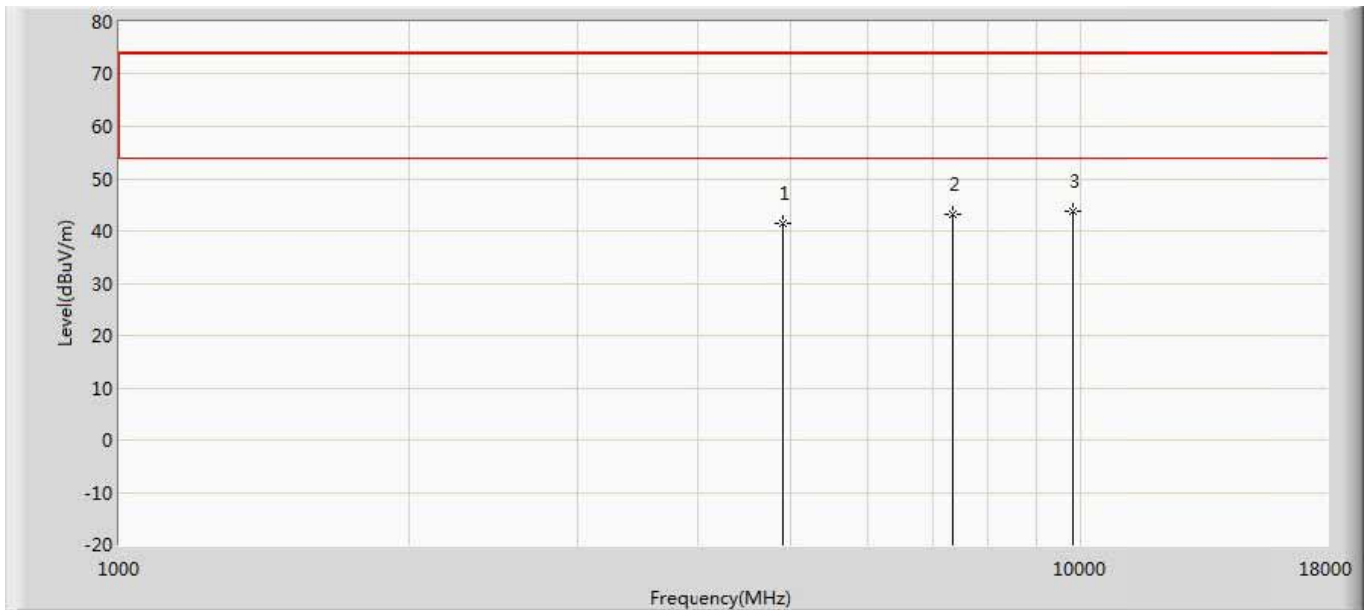

No	Mark	Frequency (MHz)	Measure Level (dBuV/m)	Reading Level (dBuV)	Over Limit (dB)	Limit (dBuV/m)	Factor (dB)	Type
1		4900.000	41.372	42.872	-32.628	74.000	-1.500	PK
2		7350.000	43.117	41.028	-30.883	74.000	2.089	PK
3	*	9800.000	43.860	38.978	-30.140	74.000	4.882	PK

Engineer: ALLEN	
Site: AC5	Time: 2018/10/18 - 11:26
Limit: FCC_Part15.209_RE(3m)	Margin: 0
Probe: Horn_3117_00167055(1-18GHz)	Polarity: Vertical
EUT: Lux BR30	Power: AC 120V/60Hz
Note: Mode 1:Transmit at 2450MHz by Zigbee	

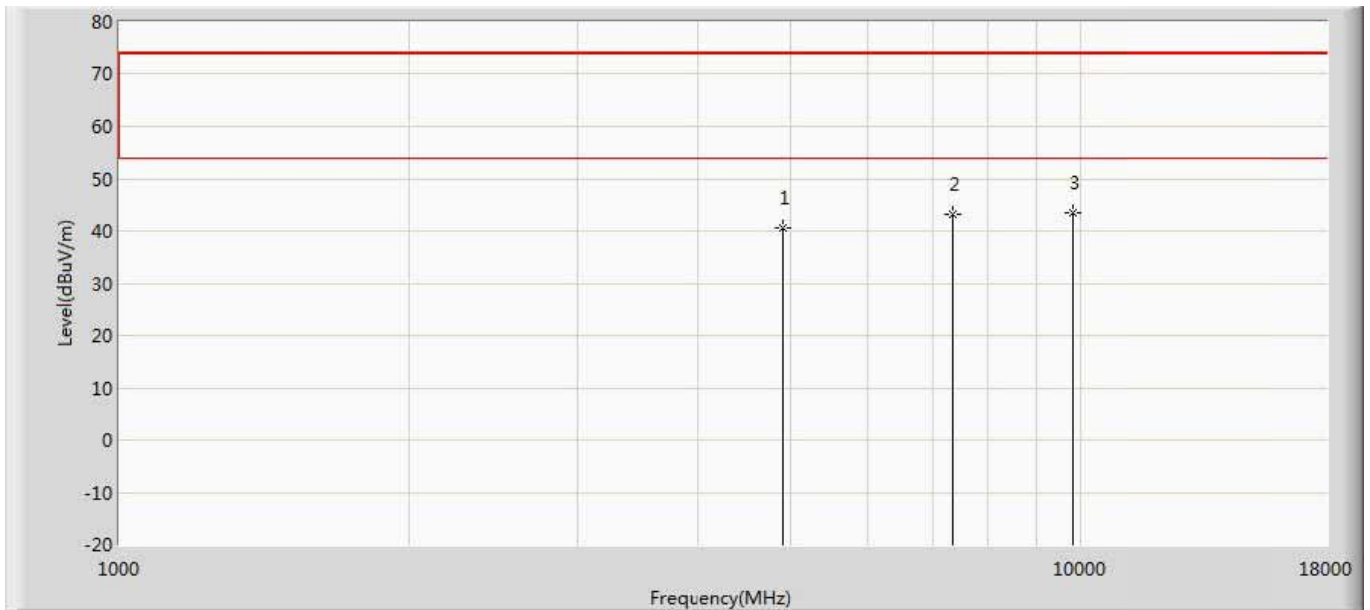

No	Mark	Frequency (MHz)	Measure Level (dBuV/m)	Reading Level (dBuV)	Over Limit (dB)	Limit (dBuV/m)	Factor (dB)	Type
1		4900.000	40.664	42.164	-33.336	74.000	-1.500	PK
2		7350.000	43.231	41.142	-30.769	74.000	2.089	PK
3	*	9800.000	43.568	38.686	-30.432	74.000	4.882	PK

Engineer: ALLEN	
Site: AC5	Time: 2018/10/18 - 11:26
Limit: FCC_Part15.209_RE(3m)	Margin: 0
Probe: Horn_3117_00167055(1-18GHz)	Polarity: Horizontal
EUT: Lux BR30	Power: AC 120V/60Hz
Note: Mode 1:Transmit at 2480MHz by Zigbee	

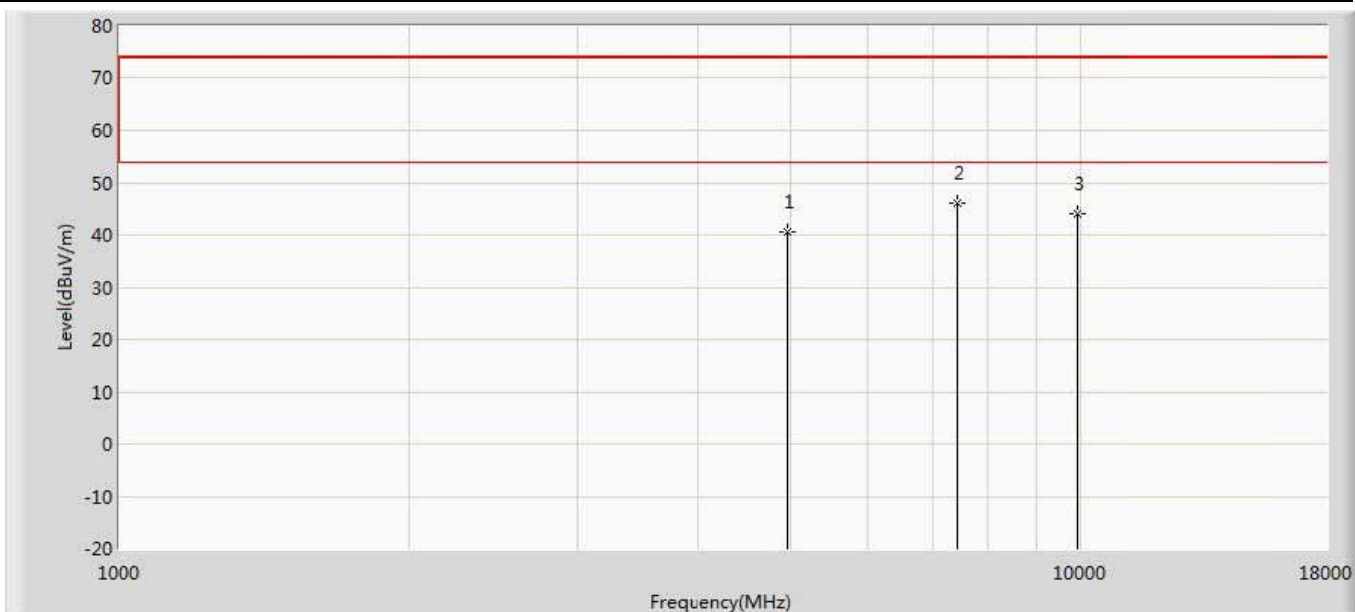

No	Mark	Frequency (MHz)	Measure Level (dBuV/m)	Reading Level (dBuV)	Over Limit (dB)	Limit (dBuV/m)	Factor (dB)	Type
1		4960.000	40.698	41.846	-33.302	74.000	-1.148	PK
2	*	7440.000	46.125	43.699	-27.875	74.000	2.426	PK
3		9920.000	44.155	38.901	-29.845	74.000	5.253	PK

Engineer: ALLEN	
Site: AC5	Time: 2018/10/18 - 11:27
Limit: FCC_Part15.209_RE(3m)	Margin: 0
Probe: Horn_3117_00167055(1-18GHz)	Polarity: Vertical
EUT: Lux BR30	Power: AC 120V/60Hz
Note: Mode 1:Transmit at 2480MHz by Zigbee	

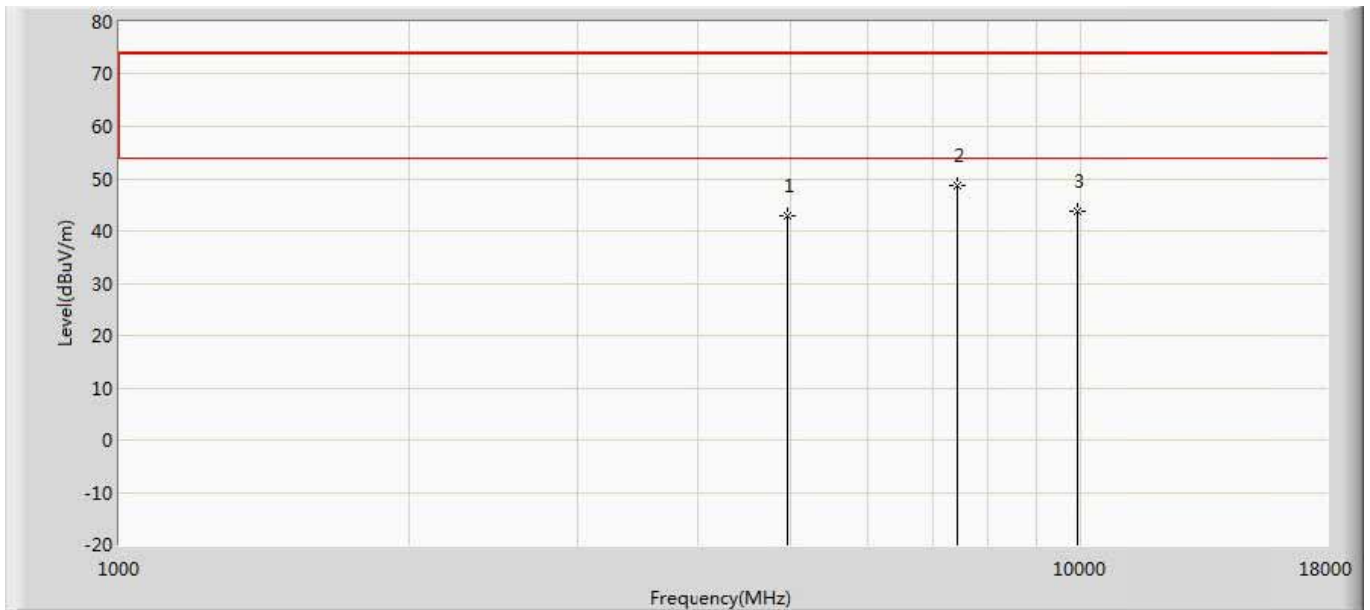

No	Mark	Frequency (MHz)	Measure Level (dBuV/m)	Reading Level (dBuV)	Over Limit (dB)	Limit (dBuV/m)	Factor (dB)	Type
1		4960.000	42.802	43.950	-31.198	74.000	-1.148	PK
2	*	7434.500	48.703	46.395	-25.297	74.000	2.308	PK
3		9920.000	43.728	38.474	-30.272	74.000	5.253	PK

Note: 1. Measure Level = Reading Level + Factor.

Note: 2. The test frequency range, 9kHz~30MHz, 18GHz~25GHz, both of the worst case are at least 20dB below the limits, therefore no data appear in the report.

Note: 3. This limit applies for using average detector, if the test result on peak is lower than average limit, then average measurement needn't be performed.

Note: 4. The RBW set up, see Clause 6.6.

Murata(XRCGB38M400FXH17R0):

Engineer: Karl	
Site: AC5	Time: 2018/11/12 - 22:34
Limit: FCC_Part15.209_RE(3m)	Margin: 0
Probe: Horn_3117_00167055(1-18GHz)	Polarity: Horizontal
EUT: Lux BR30	Power: AC 120V/60Hz
Note: Mode 1:Transmit at 2405MHz by zigbee	



No	Mark	Frequency (MHz)	Measure Level (dBuV/m)	Reading Level (dBuV)	Over Limit (dB)	Limit (dBuV/m)	Factor (dB)	Type
1		4808.000	45.702	45.511	-28.298	74.000	0.191	PK
2		7215.000	45.211	41.739	-28.789	74.000	3.472	PK
3	*	9620.000	45.849	37.416	-28.151	74.000	8.433	PK

Engineer: Karl	
Site: AC5	Time: 2018/11/12 - 22:35
Limit: FCC_Part15.209_RE(3m)	Margin: 0
Probe: Horn_3117_00167055(1-18GHz)	Polarity: Vertical
EUT: Lux BR30	Power: AC 120V/60Hz
Note: Mode 1:Transmit at 2405MHz by zigbee	

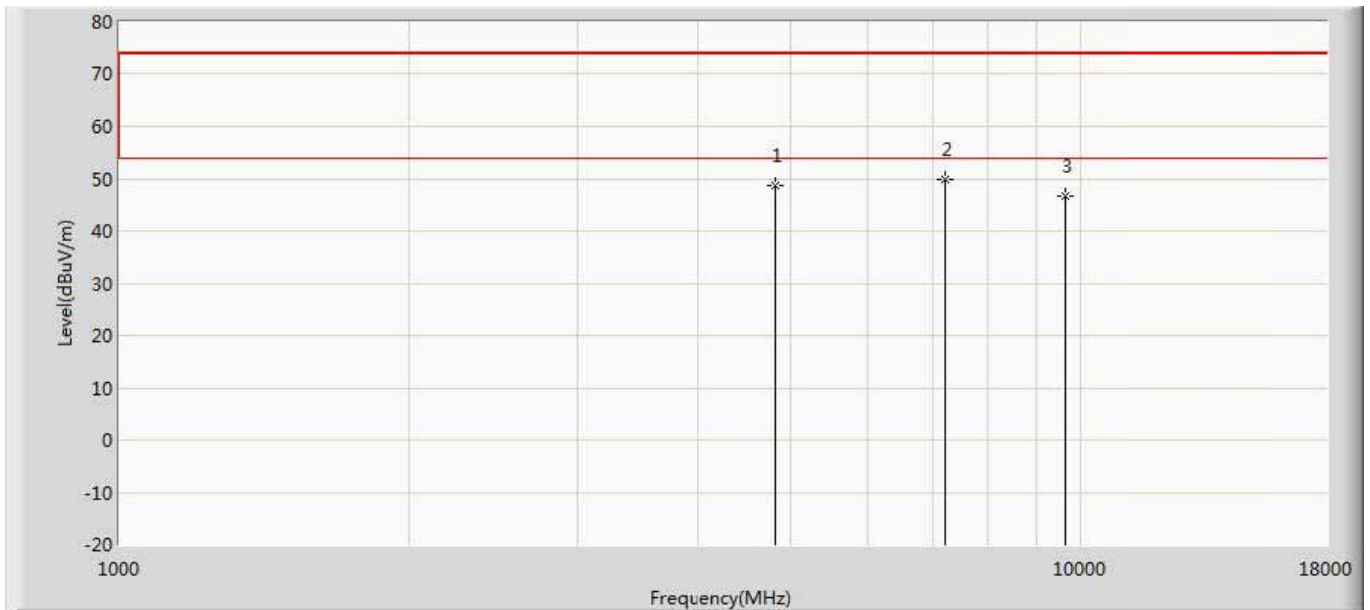

No	Mark	Frequency (MHz)	Measure Level (dBuV/m)	Reading Level (dBuV)	Over Limit (dB)	Limit (dBuV/m)	Factor (dB)	Type
1		4808.000	48.677	48.486	-25.323	74.000	0.191	PK
2	*	7213.500	49.890	46.426	-24.110	74.000	3.464	PK
3		9620.000	46.757	38.324	-27.243	74.000	8.433	PK

Engineer: Karl	
Site: AC5	Time: 2018/11/12 - 22:35
Limit: FCC_Part15.209_RE(3m)	Margin: 0
Probe: Horn_3117_00167055(1-18GHz)	Polarity: Horizontal
EUT: Lux BR30	Power: AC 120V/60Hz
Note: Mode 1:Transmit at 2440MHz by zigbee	

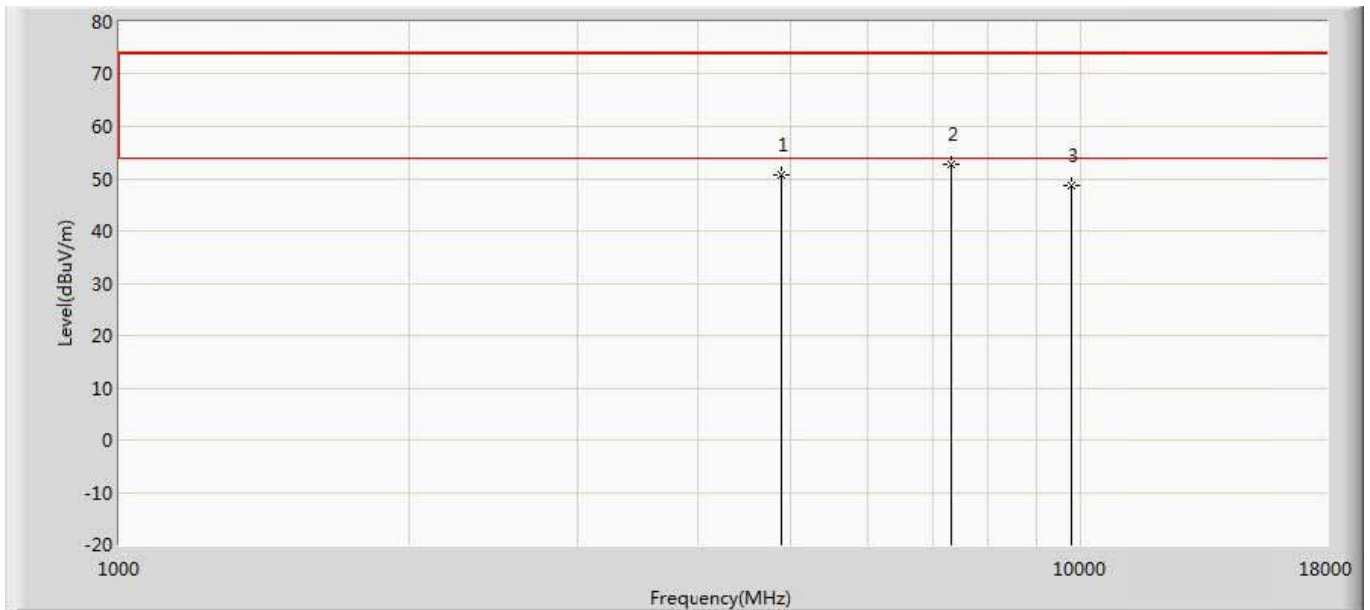

No	Mark	Frequency (MHz)	Measure Level (dBuV/m)	Reading Level (dBuV)	Over Limit (dB)	Limit (dBuV/m)	Factor (dB)	Type
1		4880.000	50.785	50.297	-23.215	74.000	0.489	PK
2	*	7320.000	52.765	49.215	-21.235	74.000	3.550	PK
3		9760.000	48.630	39.157	-25.370	74.000	9.473	PK

Engineer: Karl	
Site: AC5	Time: 2018/11/12 - 22:35
Limit: FCC_Part15.209_RE(3m)	Margin: 0
Probe: Horn_3117_00167055(1-18GHz)	Polarity: Vertical
EUT: Lux BR30	Power: AC 120V/60Hz
Note: Mode 1:Transmit at 2440MHz by zigbee	

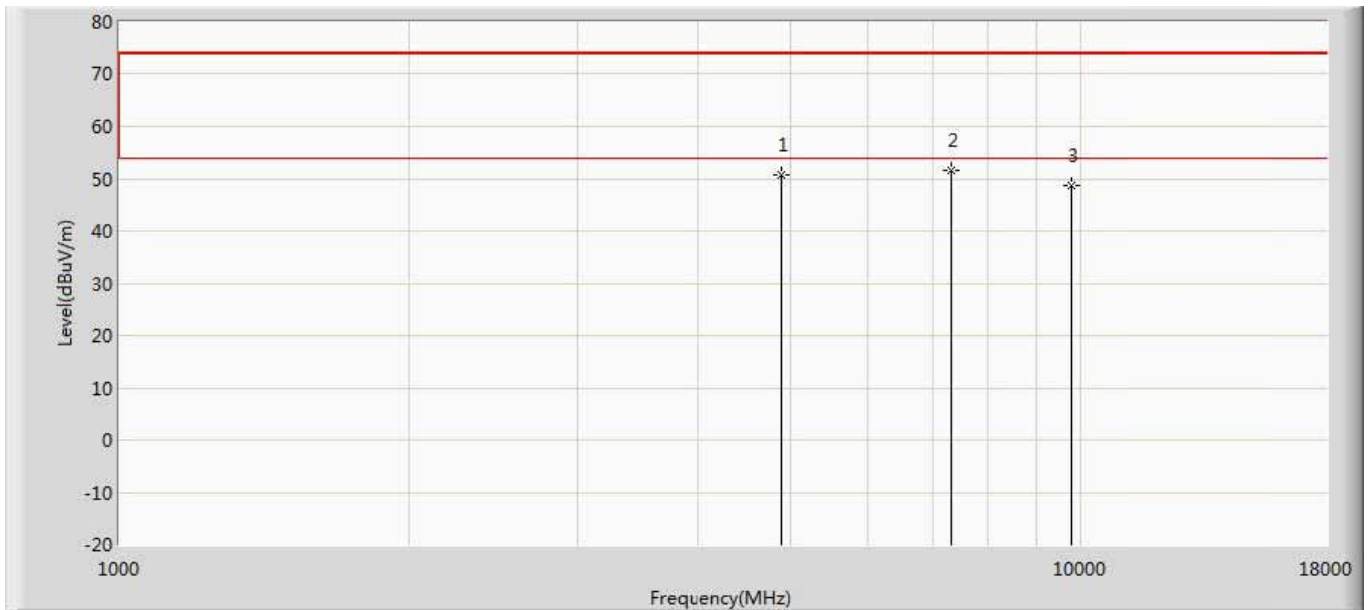

No	Mark	Frequency (MHz)	Measure Level (dBuV/m)	Reading Level (dBuV)	Over Limit (dB)	Limit (dBuV/m)	Factor (dB)	Type
1		4880.000	50.643	50.155	-23.357	74.000	0.489	PK
2	*	7320.000	51.704	48.154	-22.296	74.000	3.550	PK
3		9760.000	48.648	39.175	-25.352	74.000	9.473	PK

Engineer: Karl	
Site: AC5	Time: 2018/11/12 - 22:35
Limit: FCC_Part15.209_RE(3m)	Margin: 0
Probe: Horn_3117_00167055(1-18GHz)	Polarity: Horizontal
EUT: Lux BR30	Power: AC 120V/60Hz
Note: Mode 1:Transmit at 2480MHz by zigbee	

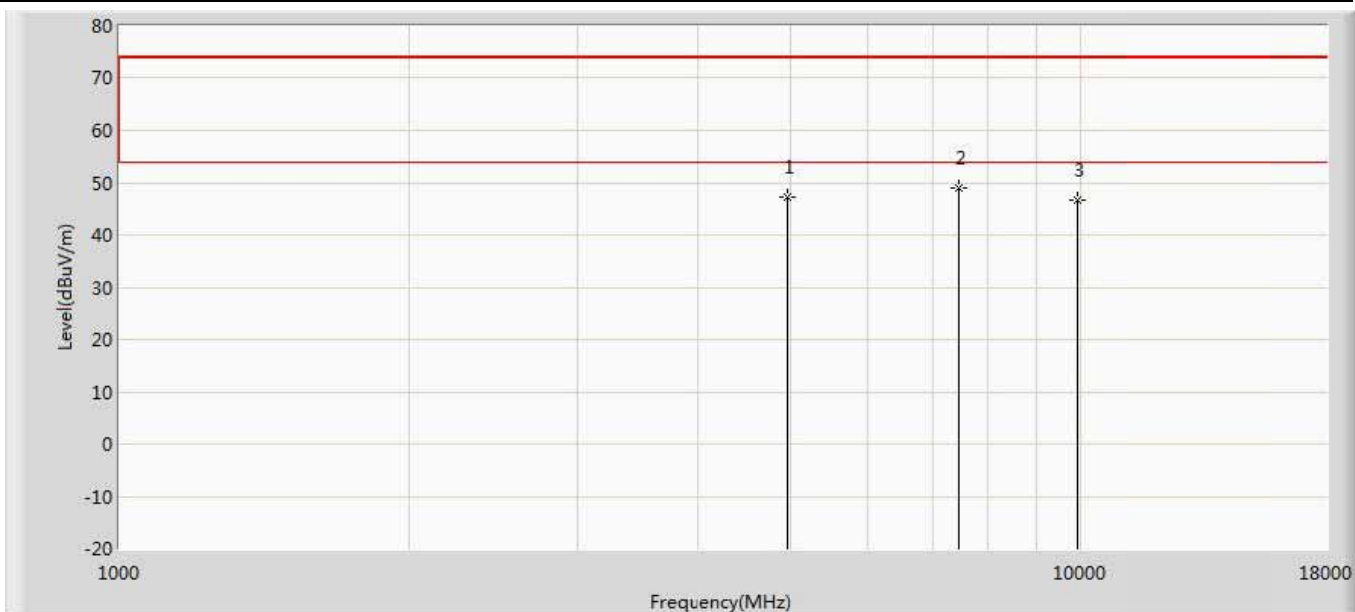

No	Mark	Frequency (MHz)	Measure Level (dBuV/m)	Reading Level (dBuV)	Over Limit (dB)	Limit (dBuV/m)	Factor (dB)	Type
1		4961.000	47.185	46.519	-26.815	74.000	0.666	PK
2	*	7443.000	48.878	44.049	-25.122	74.000	4.829	PK
3		9920.000	46.796	38.395	-27.204	74.000	8.401	PK

Engineer: Karl	
Site: AC5	Time: 2018/11/12 - 22:35
Limit: FCC_Part15.209_RE(3m)	Margin: 0
Probe: Horn_3117_00167055(1-18GHz)	Polarity: Vertical
EUT: Lux BR30	Power: AC 120V/60Hz
Note: Mode 1:Transmit at 2480MHz by zigbee	

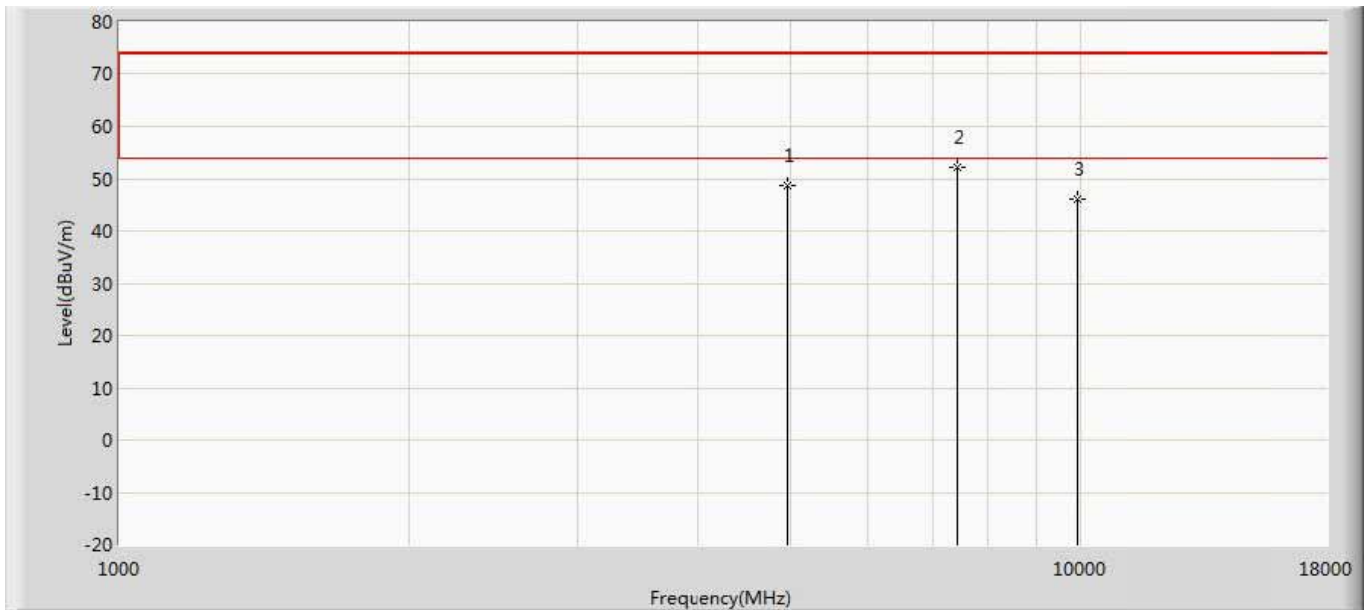

No	Mark	Frequency (MHz)	Measure Level (dBuV/m)	Reading Level (dBuV)	Over Limit (dB)	Limit (dBuV/m)	Factor (dB)	Type
1		4961.000	48.817	48.151	-25.183	74.000	0.666	PK
2	*	7434.500	52.250	47.710	-21.750	74.000	4.540	PK
3		9920.000	45.958	37.557	-28.042	74.000	8.401	PK

Note: 1. Measure Level = Reading Level + Factor.

Note: 2. The test frequency range, 9kHz~30MHz, 18GHz~25GHz, both of the worst case are at least 20dB below the limits, therefore no data appear in the report.

Note: 3. This limit applies for using average detector, if the test result on peak is lower than average limit, then average measurement needn't be performed.

Note: 4. The RBW set up, see Clause 6.6.

The worst case of Radiated Emission below 1GHz:

Site: AC2	Time: 2018/09/23
Limit: FCC_Part15.109_RE(3m)_ClassB	Margin: 0
Probe: AC2_3M(30-1000M)	Polarity: Horizontal
EUT: Lux BR30	Power: AC 120V/60Hz
Note: Mode1: Transmit at 2405MHz by Zigbee	

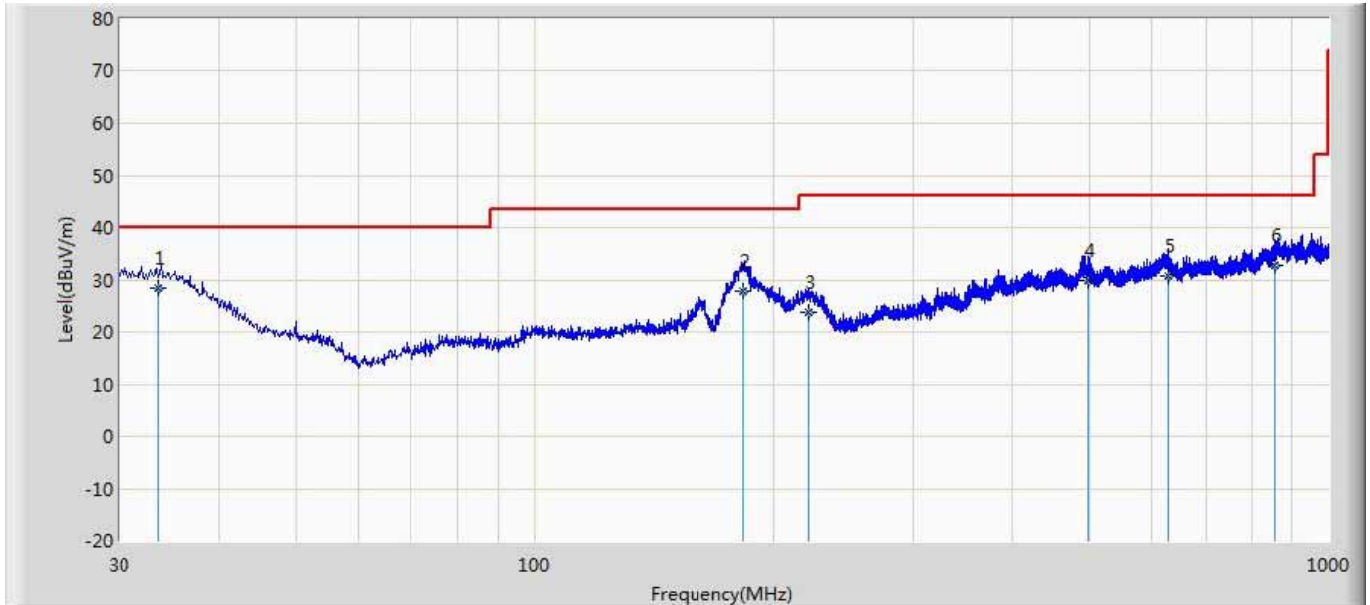

No	Mark	Frequency (MHz)	Measure Level (dBuV/m)	Reading Level (dBuV)	Over Limit (dB)	Limit (dBuV/m)	Probe (dB/m)	Cable (dB)	Amp (dB)	Ant Pos (cm)	Table Pos (deg)	Type
1	*	33.646	28.463	1.100	-11.53	40.000	20.7	6.6	0.0	100	124	QP
					7		05	58	00			
2		183.64	27.958	10.900	-15.54	43.500	9.75	7.3	0.0	200	248	QP
		9			2		1	07	00			
3		221.64	23.681	5.900	-22.31	46.000	10.3	7.4	0.0	200	332	QP
		6			9		42	40	00			
4		498.64	29.864	2.300	-16.13	46.000	19.5	8.0	0.0	100	3	QP
		6			6		26	38	00			
5		628.64	30.843	0.400	-15.15	46.000	21.8	8.5	0.0	100	119	QP
		6			7		65	78	00			
6		858.64	32.798	0.300	-13.20	46.000	23.3	9.1	0.0	200	85	QP
		6			2		47	51	00			

Note:

- " * ", means this data is the worst emission level.
- Measurement Level = Reading Level + Factor(Probe+Cable-Amp).

Site: AC2	Time: 2018/09/13
Limit: FCC_Part15.109_RE(3m)_ClassB	Margin: 0
Probe: AC2_3M(30-1000M)	Polarity: Vertical
EUT: Lux BR30	Power: AC 120V/60Hz
Note: Mode1: Transmit at 2405MHz by Zigbee	

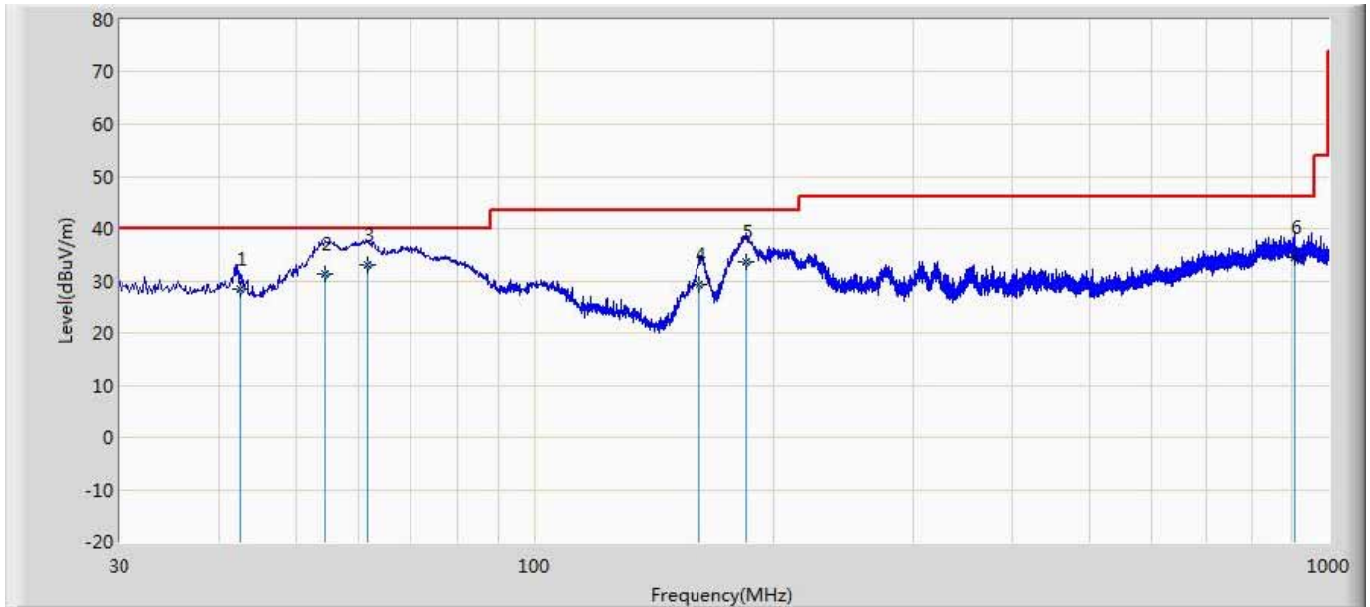

No	Mark	Frequency (MHz)	Measure Level (dBuV/m)	Reading Level (dBuV)	Over Limit (dB)	Limit (dBuV/m)	Probe (dB/m)	Cable (dB)	Amp (dB)	Ant Pos (cm)	Table Pos (deg)	Type
1		42.646	28.538	10.100	-11.46	40.000	11.8	6.5	0.0	100	208	QP
					2		58	80	00			
2		54.349	31.432	13.600	-8.568	40.000	11.2	6.6	0.0	100	90	QP
							12	20	00			
3	*	61.636	33.181	16.900	-6.819	40.000	9.56	6.7	0.0	100	15	QP
							8	14	00			
4		161.64	29.371	10.300	-14.12	43.500	11.8	7.2	0.0	200	332	QP
		6			9		17	54	00			
5		184.64	33.594	13.600	-9.906	43.500	12.6	7.3	0.0	200	158	QP
		6					85	09	00			
6		909.64	34.384	1.600	-11.61	46.000	23.5	9.2	0.0	200	315	QP
		6			6		15	69	00			

Note:

- " * ", means this data is the worst emission level.
- Measurement Level = Reading Level + Factor(Probe+Cable-Amp).

5. Emissions in non-restricted frequency bands

5.1. Test Equipment

Emissions in non-restricted frequency bands / TR-8					
Instrument	Manufacturer	Type No.	Serial No.	Cal. Date	Cal. Due Date
Spectrum Analyzer	Agilent	N9010A	MY48030494	2018.02.04	2019.01.15
EXA Spectrum Analyzer	Keysight	N9010A	MY55370495	2018.04.09	2019.04.08
MXA Signal Analyzer	Keysight	N9020A	MY56060147	2018.04.09	2019.04.08
Temperature/Humidity Meter	zhichen	ZC1-2	TR8-TH	2018.04.10	2019.04.09

Note: All equipments are calibrated with traceable calibrations. Each calibration is traceable to the national or international standards.

5.2. Test Setup

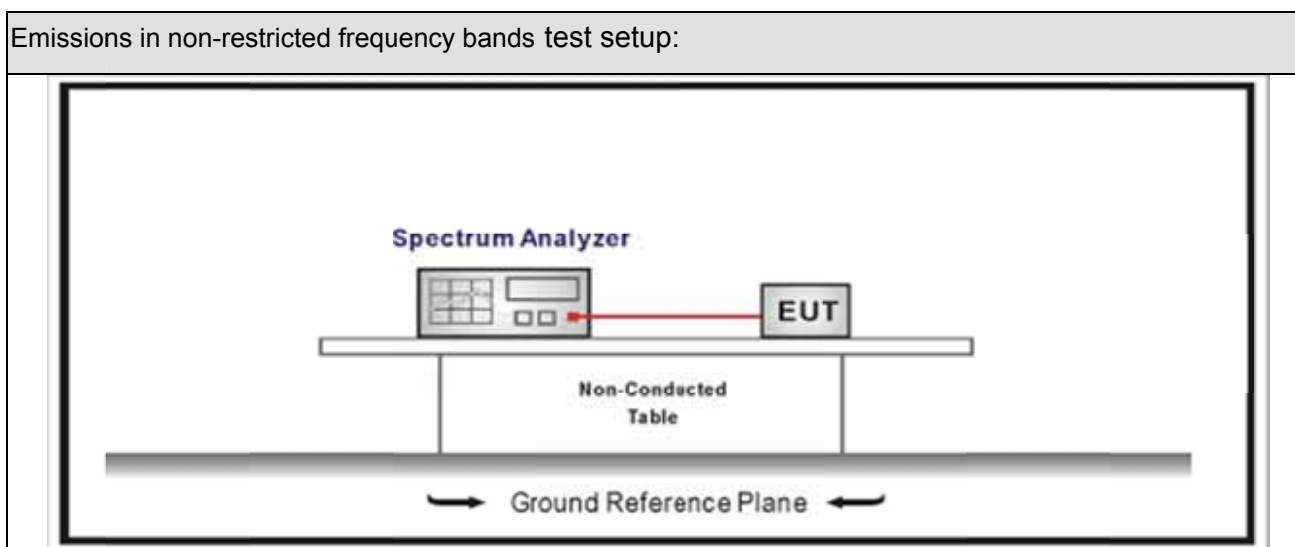



5.3. Limit

Un-Restricted Band Emissions Limit	
RF Output power (Detection methods)	Limit(dB)
RF Output power(Average detector)	30c(Note1)
RF Output power(PK detector)	20c(Note2)
<p>Note 1: If maximum conducted (average) output power was used to demonstrate compliance as described in 9.2, then the peak power in any 100 kHz bandwidth outside of the authorized frequency band shall be attenuated by at least 30 dB relative to the maximum in-band peak PSD level in 100 kHz (i.e., 30 dBc).</p> <p>Note 2: If the maximum peak conducted output power procedure was used, then the peak output power measured in any 100 kHz bandwidth outside of the authorized frequency band shall be attenuated by at least 20 dB relative to the maximum in-band peak PSD level in 100 kHz (i.e., 20 dBc).</p>	

5.4. Test Procedure

Test Method			
	References Rule	Chapter	Description
<input checked="" type="checkbox"/>	ANSI C63.10	11.11	Emissions in non-restricted frequency bands
	<input checked="" type="checkbox"/> ANSI C63.10	11.11.2	Reference level measurement
	<input checked="" type="checkbox"/> ANSI C63.10	11.11.3	Emission level measurement
<input type="checkbox"/>	ANSI C63.10	11.12	Emissions in restricted frequency bands
	<input type="checkbox"/> ANSI C63.10	11.12.1	Radiated emission measurements
	<input type="checkbox"/> ANSI C63.10	11.12.2.7	Radiated spurious emission test
<input type="checkbox"/>	ANSI C63.10	6.4	Radiated emissions from unlicensed wireless devices below 30 MHz
<input type="checkbox"/>	ANSI C63.10	6.5	Radiated emissions from unlicensed wireless devices in the frequency range of 30 MHz to 1000 MHz
<input type="checkbox"/>	ANSI C63.10	6.6	Radiated emissions from unlicensed wireless devices above 1 GHz
	<input type="checkbox"/> ANSI C63.10	11.12.2	Antenna-port conducted measurements
	<input type="checkbox"/> ANSI C63.10	11.12.2.3	Quasi-peak measurement procedure
	<input type="checkbox"/> ANSI C63.10	11.12.2.4	Peak power measurement procedure
	<input type="checkbox"/> ANSI C63.10	11.12.2.5	Average power measurement procedures
	<input type="checkbox"/> ANSI C63.10	11.12.2.5.1	Trace averaging with continuous EUT transmission at full power
	<input type="checkbox"/> ANSI C63.10	11.12.2.5.2	Trace averaging across ON and OFF times of the EUT transmissions followed by duty cycle correction
	<input type="checkbox"/> ANSI C63.10	11.12.2.5.3	Reduced VBW averaging across ON and OFF times of the EUT transmissions with max hold

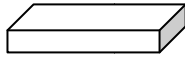
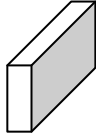
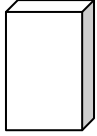
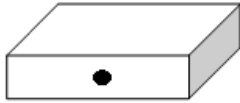
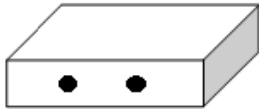
5.5. EUT test Axis definition

Item	Emissions in non-restricted frequency bands			
Device Category	<input type="checkbox"/>	Fixed point-to-point		
	<input type="checkbox"/>	Emit multiple directional beams, simultaneously or sequentially		
	<input checked="" type="checkbox"/>	Other cases		
Test mode	Mode 1			
Test method	<input type="checkbox"/>	Radiated		
		X Axis	Y Axis	Z Axis
				
		Worst Axis <input type="checkbox"/>	Worst Axis <input type="checkbox"/>	Worst Axis <input type="checkbox"/>
	<input checked="" type="checkbox"/>	Conducted		
	<input checked="" type="checkbox"/>	Chain 0		
				
	<input type="checkbox"/>	Chain 0	Chain 1	
				
		Worst Chain <input type="checkbox"/>	Worst Chain <input type="checkbox"/>	
	<input type="checkbox"/>	Chain 0	Chain 1	Chain 2
				
	Worst Chain <input type="checkbox"/>	Worst Chain <input type="checkbox"/>	Worst Chain <input type="checkbox"/>	

5.6. Test Result

Product Name	: LED lamp	Power	: AC 120V/60Hz
Test Mode	: Mode 1	Test Site	: TR-8
Test Date	: 2018.09.17		

Mode	Channel	Test Frequency (MHz)	In-Band PSD[a] (dBm/100kHz)	Frequency (MHz)	Out-Band PSD[b] (dBm/100kHz)	[a]-[b] (dB)	Limit (dB)	Result
1	11	2405	5.404	2400.00	-51.140	56.544	>20	Pass
1	26	2480	4.997	2500.00	-61.149	66.146	>20	Pass

Note: The worst case of Emissions in non-restricted frequency bands as below:

Mode 1 CH11 (2405MHz)



6. Radiated Emission Band Edge

6.1. Test Equipment

Radiated Emission Band Edge / AC-5					
Instrument	Manufacturer	Type No.	Serial No.	Cal. Date	Cal. Due Date
EMI Receiver	Agilent	N9038A	MY51210196	2018.07.16	2019.07.15
Pre-Amplifier	Miteq	NSP1800-25	1364185	2018.05.03	2019.05.02
DRG Horn Antenna	ETS-Lindgren	3117	00167055	2018.07.12	2019.07.11
Broad-Band Horn Antenna	Schwarzbeck	BBHA9170	294	2018.09.18	2019.09.17
Coaxial Cable	Huber+Suhner	SUCOFLEX 106	AC5-C1	2018.02.28	2019.02.27
Coaxial Cable	Huber+Suhner	SUCOFLEX 106	AC5-C2	2018.02.28	2019.02.27
Temperature/Humidity Meter	Zhichen	ZC1-2	AC5-TH	2018.01.05	2019.01.04

6.2. Test Setup

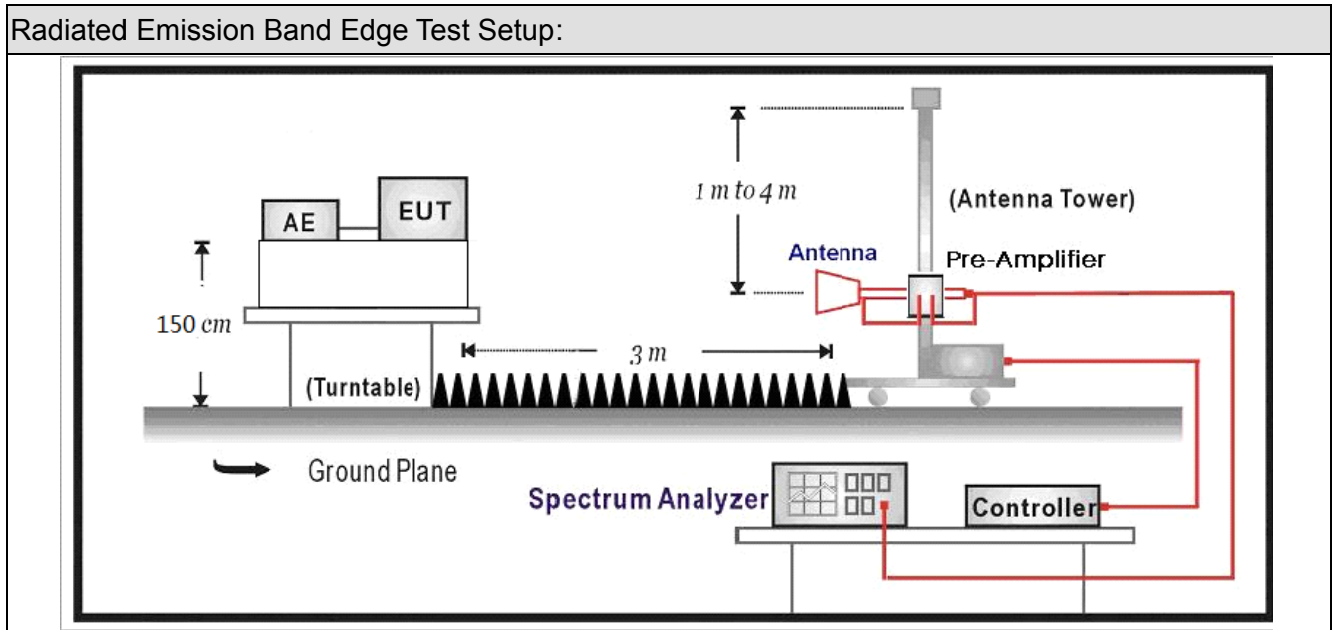

6.3. Limit



Band edge Limit				
Frequency bands (MHz)	Detector	Limit (dB μ V/m)	RBW (MHz)	Distance (m)
2310-2390	PK	74	1	3
2483.5-2500	AV	54	1	3

Note: The field strength of emissions appearing within these frequency bands shall not exceed the limits.

6.4. Test Procedure

Test Method			
	References Rule	Chapter	Description
<input checked="" type="checkbox"/>	ANSI C63.10	6.10	Band-edge testing
	<input checked="" type="checkbox"/> ANSI C63.10	6.10.5	Restricted-band band-edge measurements
	<input type="checkbox"/> ANSI C63.10	6.10.6	Marker-delta method
<input checked="" type="checkbox"/>	ANSI C63.10	11.12	Emissions in restricted frequency bands
	<input checked="" type="checkbox"/> ANSI C63.10	11.12.1	Radiated emission measurements
	<input checked="" type="checkbox"/> ANSI C63.10	11.12.2.7	Radiated spurious emission test
<input type="checkbox"/>	ANSI C63.10	6.4	Radiated emissions from unlicensed wireless devices below 30 MHz
<input type="checkbox"/>	ANSI C63.10	6.5	Radiated emissions from unlicensed wireless devices in the frequency range of 30 MHz to 1000 MHz
<input checked="" type="checkbox"/>	ANSI C63.10	6.6	Radiated emissions from unlicensed wireless devices above 1 GHz
	<input type="checkbox"/> ANSI C63.10	11.12.2.3	Quasi-peak measurement procedure
	<input type="checkbox"/> ANSI C63.10	11.12.2.4	Peak power measurement procedure
	<input type="checkbox"/> ANSI C63.10	11.12.2.5	Average power measurement procedures
	<input type="checkbox"/> ANSI C63.10	11.12.2.5.1	Trace averaging with continuous EUT transmission at full power
	<input type="checkbox"/> ANSI C63.10	11.12.2.5.2	Trace averaging across ON and OFF times of the EUT transmissions followed by duty cycle correction
	<input type="checkbox"/> ANSI C63.10	11.12.2.5.3	Reduced VBW averaging across ON and OFF times of the EUT transmissions with max hold

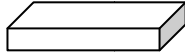
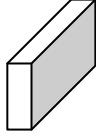
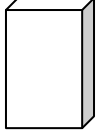
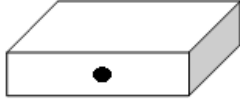
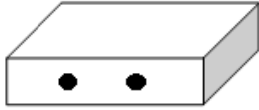
6.5. EUT test definition

Item	Radiated Emission Band Edge			
Device Category	<input type="checkbox"/>	Fixed point-to-point		
	<input type="checkbox"/>	Emit multiple directional beams, simultaneously or sequentially		
	<input checked="" type="checkbox"/>	Other cases		
Test mode	Mode 1			
Test method	<input checked="" type="checkbox"/>	Radiated		
		X Axis	Y Axis	Z Axis
				
		Worst Axis <input checked="" type="checkbox"/>	Worst Axis <input type="checkbox"/>	Worst Axis <input type="checkbox"/>
	<input type="checkbox"/>	Conducted		
	<input type="checkbox"/>	Chain 0		
				
	<input type="checkbox"/>	Chain 0	Chain 1	
				
	<input type="checkbox"/>	Chain 0	Chain 1	Chain 2
				

6.6. Duty Cycle

Test Mode	Tx On (ms)	Tx Off (ms)	Reduced VBW (Hz)	Tx On + Tx Off (ms)	Duty Cycle
Zigbee	N/A	N/A	10	N/A	100%

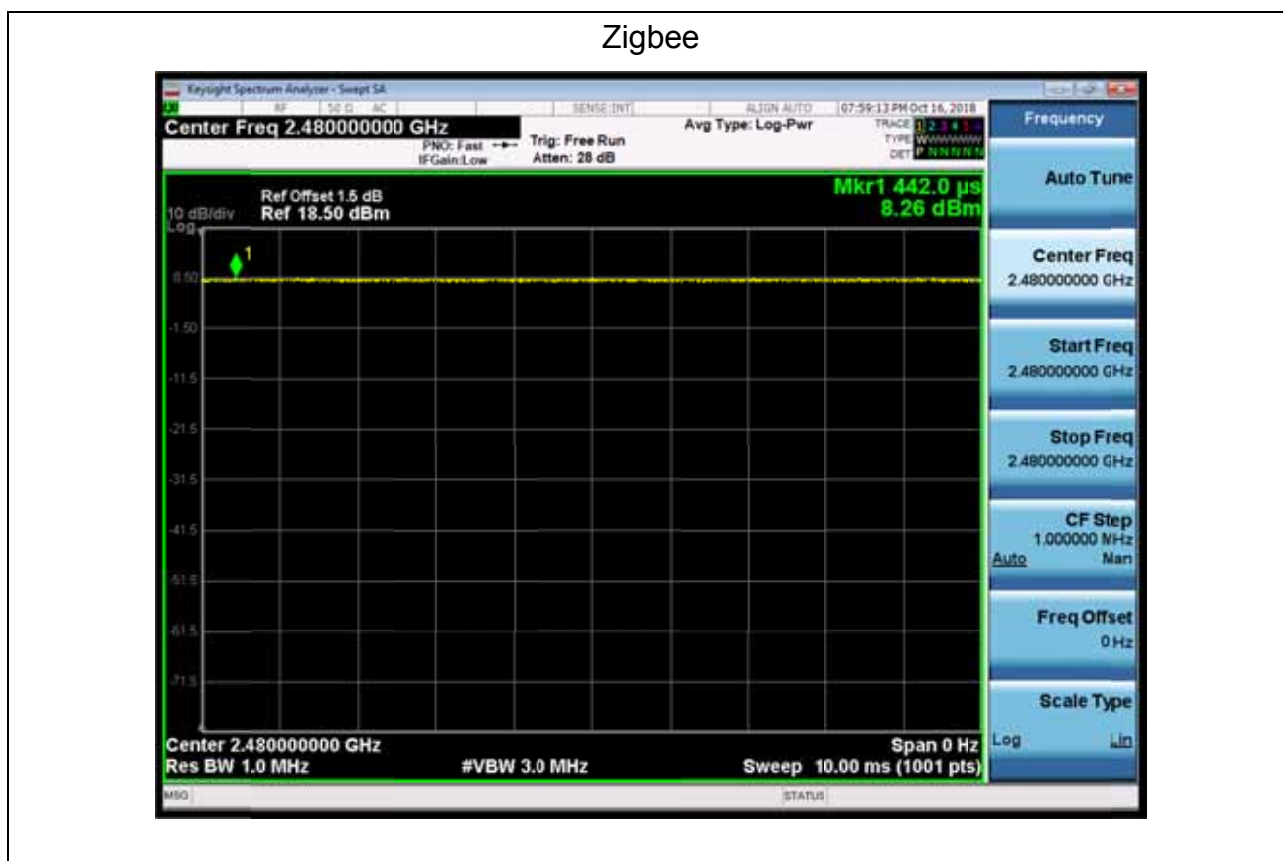

6.7 Test Result

Diode (FL3840023)_2017:

Engineer: ALLEN	
Site: AC5	Time: 2018/10/18 - 10:52
Limit: FCC_Part15.209_RE(3m)	Margin: 0
Probe: Horn_3117_00167055(1-18GHz)	Polarity: Vertical
EUT: Lux BR30	Power: AC 120V/60Hz
Note: Mode 1:Transmit at 2405MHz by Zigbee	

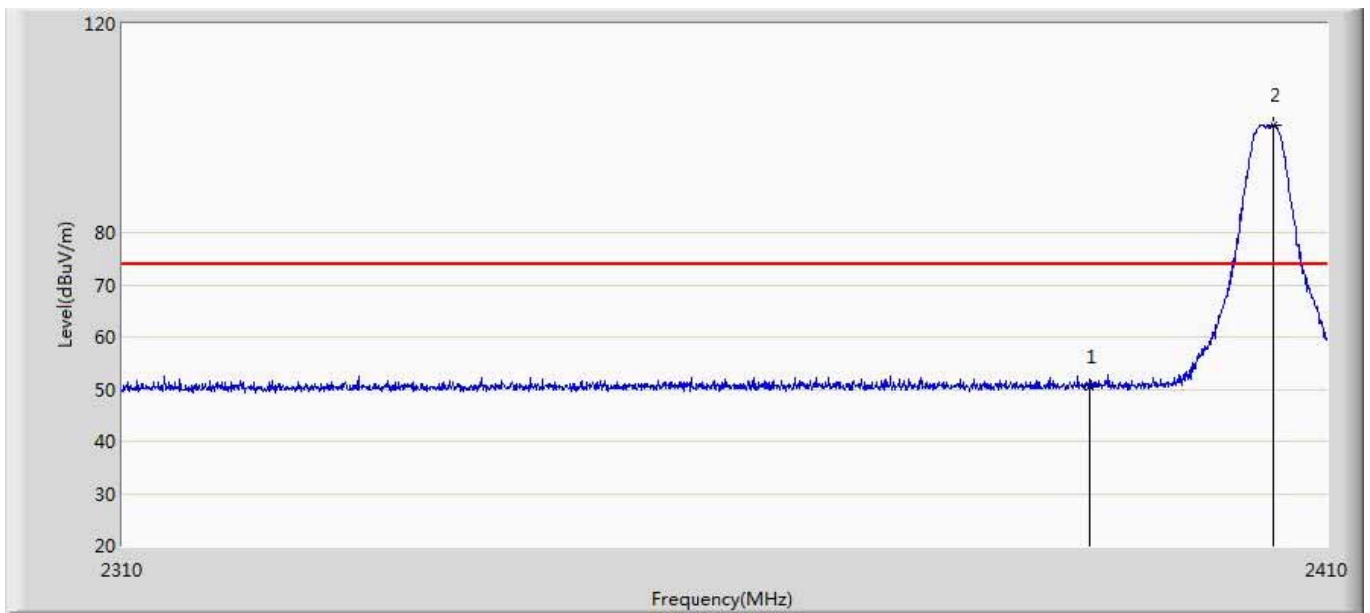

No	Mark	Frequency (MHz)	Measure Level (dBuV/m)	Reading Level (dBuV)	Over Limit (dB)	Limit (dBuV/m)	Factor (dB)	Type
1		2390.000	50.469	14.787	-23.531	74.000	35.682	PK
2	*	2405.500	100.592	64.870	26.592	74.000	35.723	PK

Engineer: ALLEN	
Site: AC5	Time: 2018/10/18 - 10:57
Limit: FCC_Part15.209_RE(3m)	Margin: 0
Probe: Horn_3117_00167055(1-18GHz)	Polarity: Vertical
EUT: Lux BR30	Power: AC 120V/60Hz
Note: Mode 1:Transmit at 2405MHz by Zigbee	

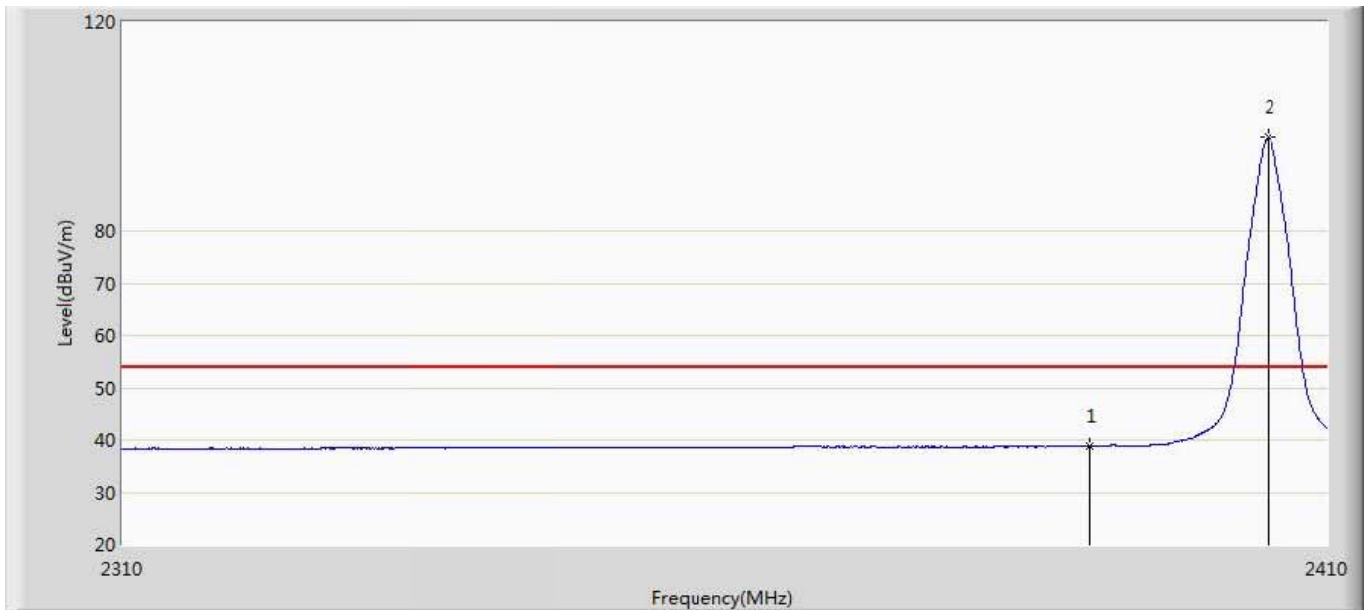

No	Mark	Frequency (MHz)	Measure Level (dBuV/m)	Reading Level (dBuV)	Over Limit (dB)	Limit (dBuV/m)	Factor (dB)	Type
1		2390.000	38.899	3.217	-15.101	54.000	35.682	AV
2	*	2405.000	97.839	62.118	43.839	54.000	35.721	AV

Engineer: ALLEN	
Site: AC5	Time: 2018/10/18 - 10:59
Limit: FCC_Part15.209_RE(3m)	Margin: 0
Probe: Horn_3117_00167055(1-18GHz)	Polarity: Horizontal
EUT: Lux BR30	Power: AC 120V/60Hz
Note: Mode 1:Transmit at 2405MHz by Zigbee	

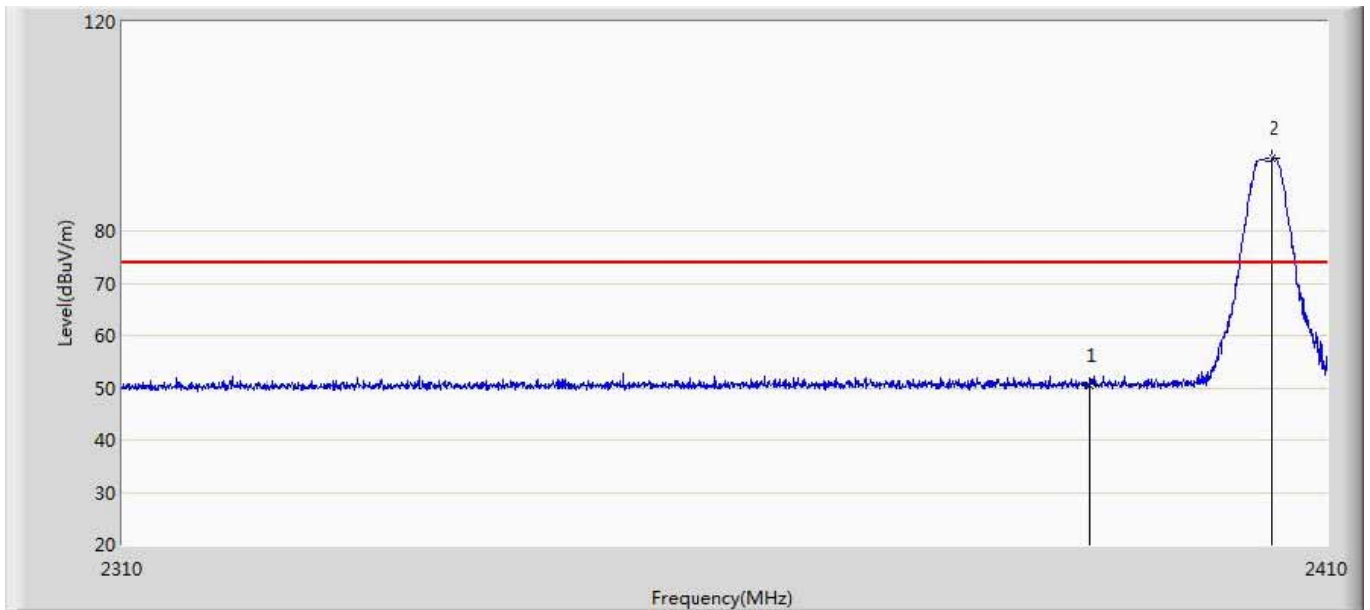

No	Mark	Frequency (MHz)	Measure Level (dBuV/m)	Reading Level (dBuV)	Over Limit (dB)	Limit (dBuV/m)	Factor (dB)	Type
1		2390.000	50.516	14.834	-23.484	74.000	35.682	PK
2	*	2405.400	93.780	58.058	19.780	74.000	35.722	PK

Engineer: ALLEN	
Site: AC5	Time: 2018/10/18 - 11:01
Limit: FCC_Part15.209_RE(3m)	Margin: 0
Probe: Horn_3117_00167055(1-18GHz)	Polarity: Horizontal
EUT: Lux BR30	Power: AC 120V/60Hz
Note: Mode 1:Transmit at 2405MHz by Zigbee	

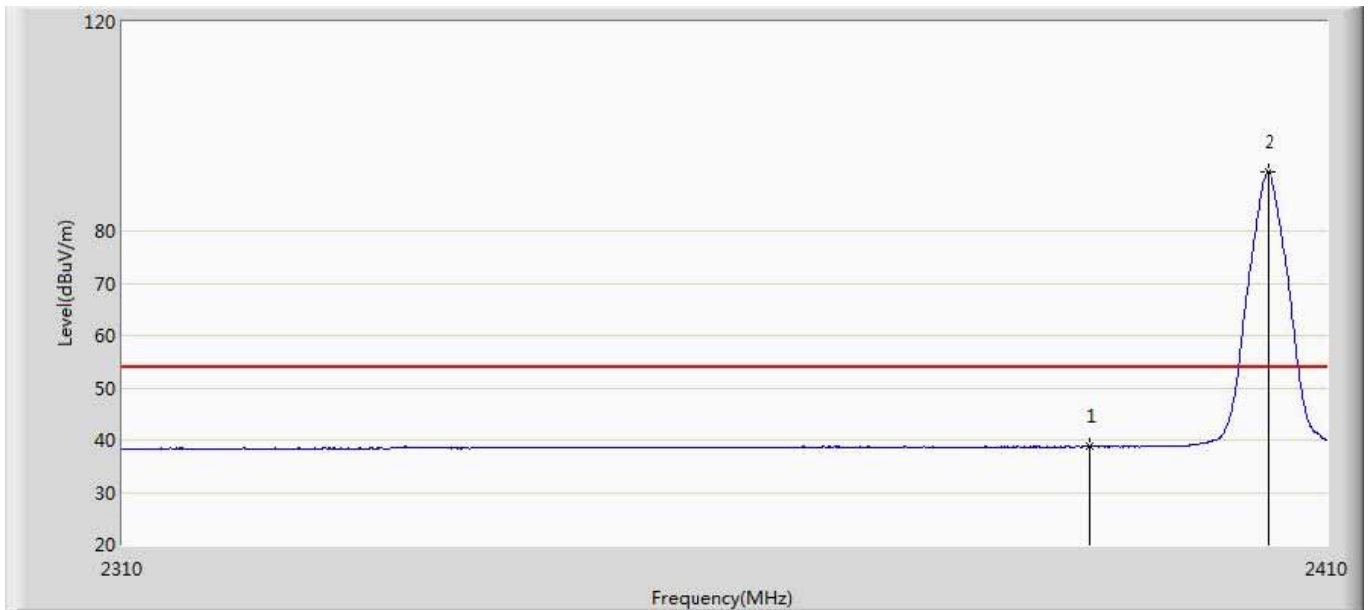

No	Mark	Frequency (MHz)	Measure Level (dBuV/m)	Reading Level (dBuV)	Over Limit (dB)	Limit (dBuV/m)	Factor (dB)	Type
1		2390.000	38.731	3.049	-15.269	54.000	35.682	AV
2	*	2404.950	91.301	55.580	37.301	54.000	35.721	AV

Engineer: ALLEN	
Site: AC5	Time: 2018/10/18 - 11:04
Limit: FCC_Part15.209_RE(3m)	Margin: 0
Probe: Horn_3117_00167055(1-18GHz)	Polarity: Vertical
EUT: Lux BR30	Power: AC 120V/60Hz
Note: Mode 1:Transmit at 2480MHz by Zigbee	

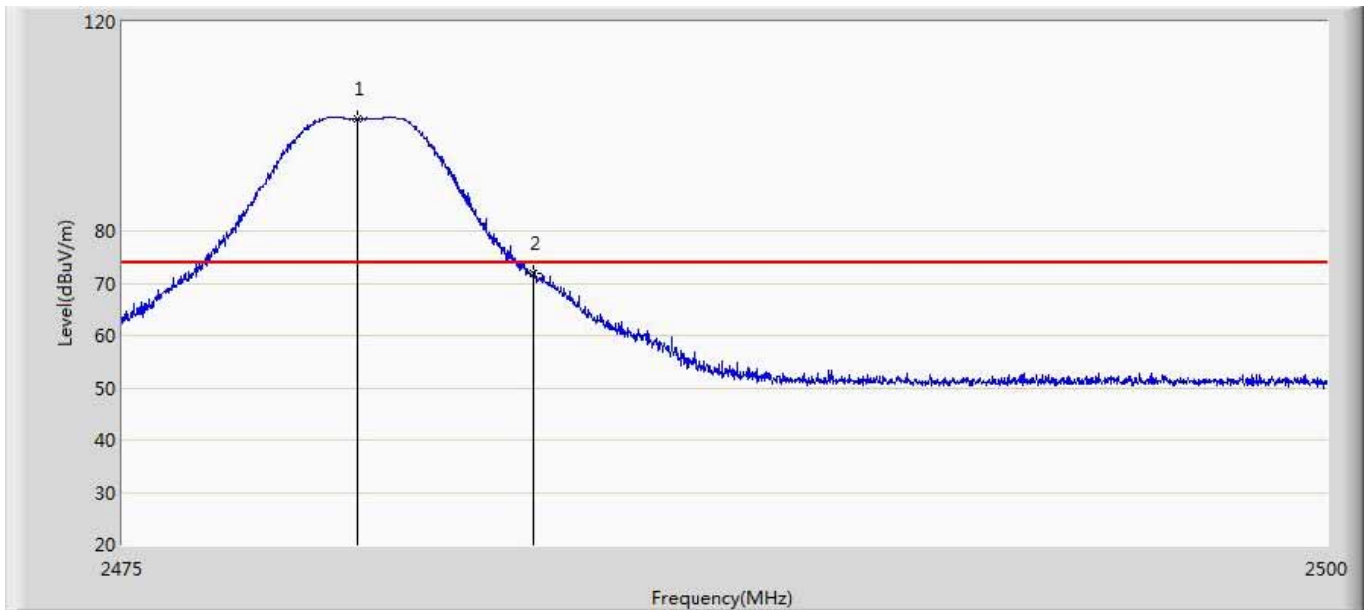

No	Mark	Frequency (MHz)	Measure Level (dBuV/m)	Reading Level (dBuV)	Over Limit (dB)	Limit (dBuV/m)	Factor (dB)	Type
1	*	2479.875	101.565	65.700	27.565	74.000	35.865	PK
2		2483.500	71.948	36.056	-2.052	74.000	35.891	PK

Engineer: ALLEN	
Site: AC5	Time: 2018/10/18 - 11:06
Limit: FCC_Part15.209_RE(3m)	Margin: 0
Probe: Horn_3117_00167055(1-18GHz)	Polarity: Vertical
EUT: Lux BR30	Power: AC 120V/60Hz
Note: Mode 1:Transmit at 2480MHz by Zigbee	

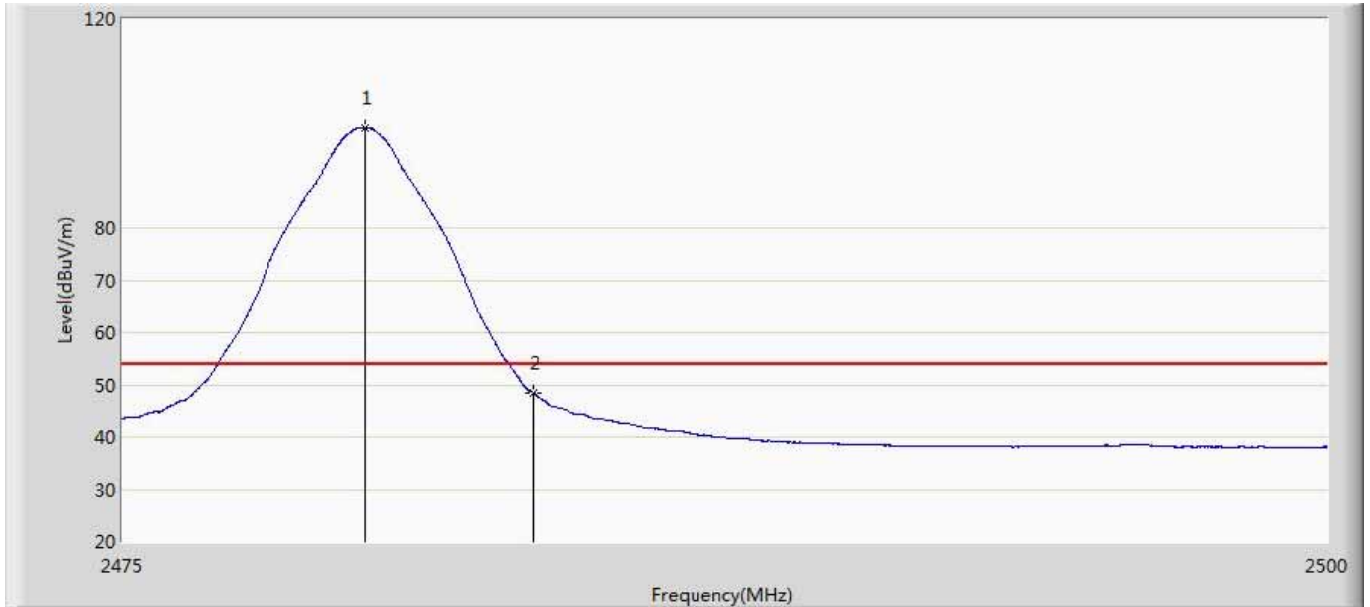

No	Mark	Frequency (MHz)	Measure Level (dBuV/m)	Reading Level (dBuV)	Over Limit (dB)	Limit (dBuV/m)	Factor (dB)	Type
1	*	2480.012	99.251	63.385	45.251	54.000	35.866	AV
2		2483.500	48.391	12.499	-5.609	54.000	35.891	AV

Engineer: ALLEN	
Site: AC5	Time: 2018/10/18 - 11:08
Limit: FCC_Part15.209_RE(3m)	Margin: 0
Probe: Horn_3117_00167055(1-18GHz)	Polarity: Horizontal
EUT: Lux BR30	Power: AC 120V/60Hz
Note: Mode 1:Transmit at 2480MHz by Zigbee	

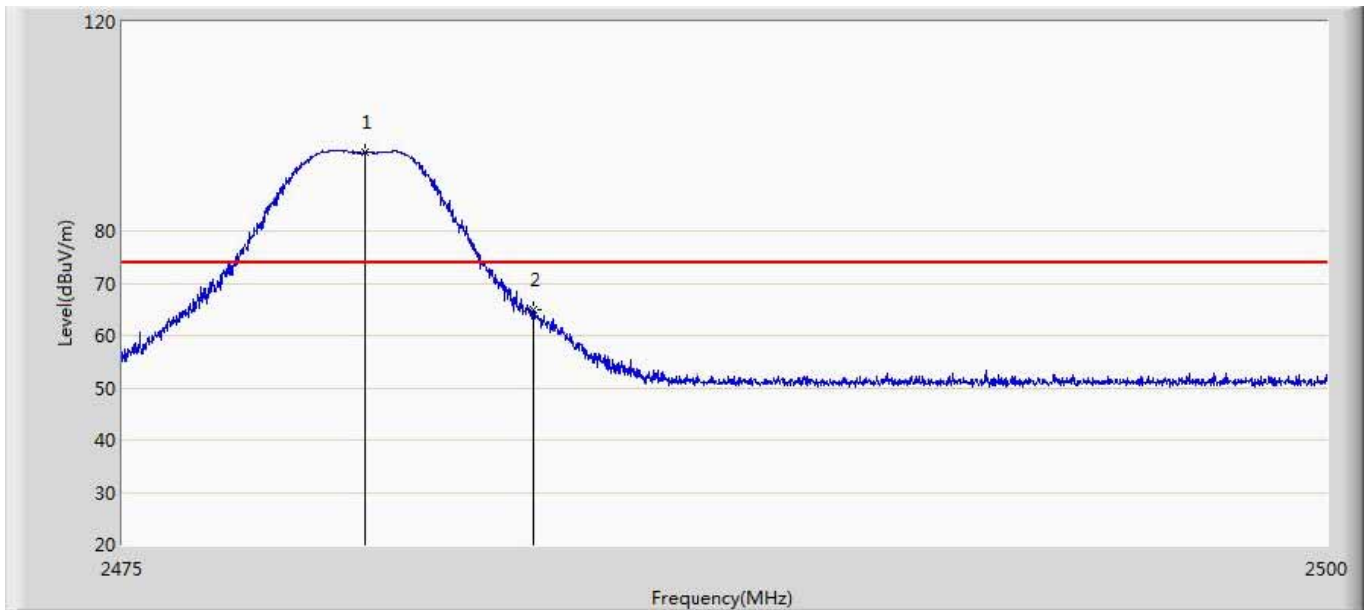

No	Mark	Frequency (MHz)	Measure Level (dBuV/m)	Reading Level (dBuV)	Over Limit (dB)	Limit (dBuV/m)	Factor (dB)	Type
1	*	2480.025	95.025	59.158	21.025	74.000	35.866	PK
2		2483.500	64.806	28.914	-9.194	74.000	35.891	PK

Engineer: ALLEN	
Site: AC5	Time: 2018/10/18 - 11:10
Limit: FCC_Part15.209_RE(3m)	Margin: 0
Probe: Horn_3117_00167055(1-18GHz)	Polarity: Horizontal
EUT: Lux BR30	Power: AC 120V/60Hz
Note: Mode 1:Transmit at 2480MHz by Zigbee	

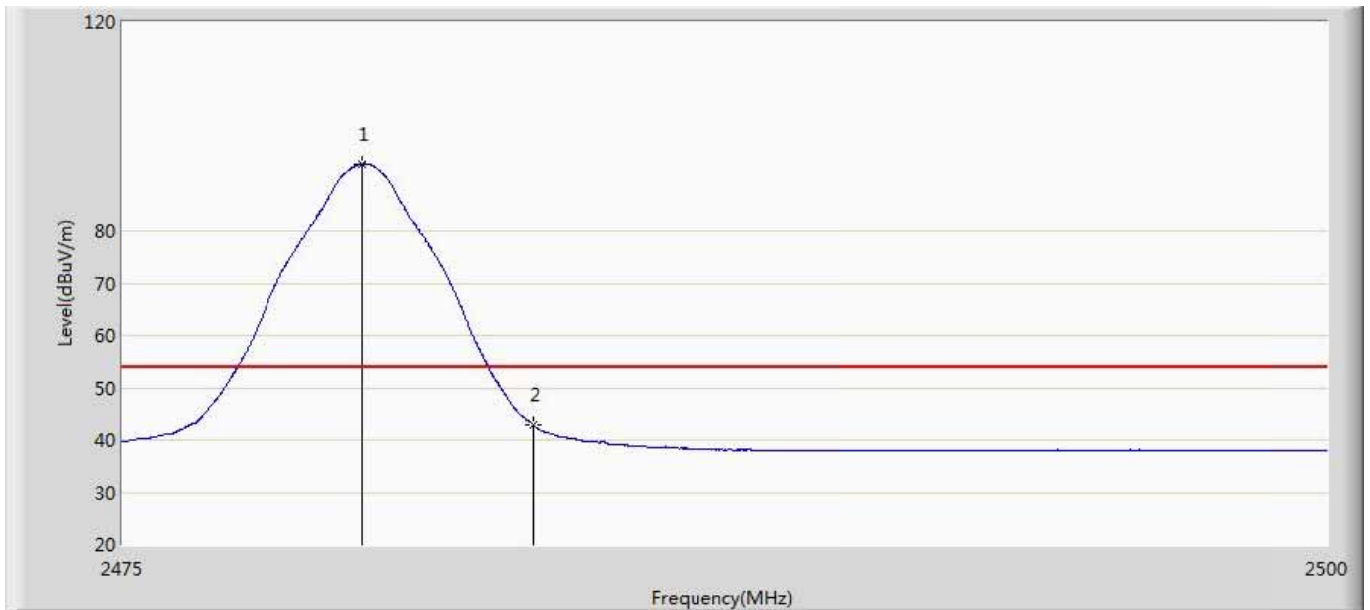

No	Mark	Frequency (MHz)	Measure Level (dBuV/m)	Reading Level (dBuV)	Over Limit (dB)	Limit (dBuV/m)	Factor (dB)	Type
1	*	2479.975	92.831	56.965	38.831	54.000	35.866	AV
2		2483.500	42.894	7.002	-11.106	54.000	35.891	AV

Murata(XRCGB38M400FXH17R0):

Engineer: Karl	
Site: AC5	Time: 2018/11/12 - 21:36
Limit: FCC_Part15.209_RE(3m)	Margin: 0
Probe: Horn_3117_00167055(1-18GHz)	Polarity: Horizontal
EUT: Lux BR30	Power: AC 120V/60Hz
Note: Mode 1:Transmit at 2405MHz by zigbee	

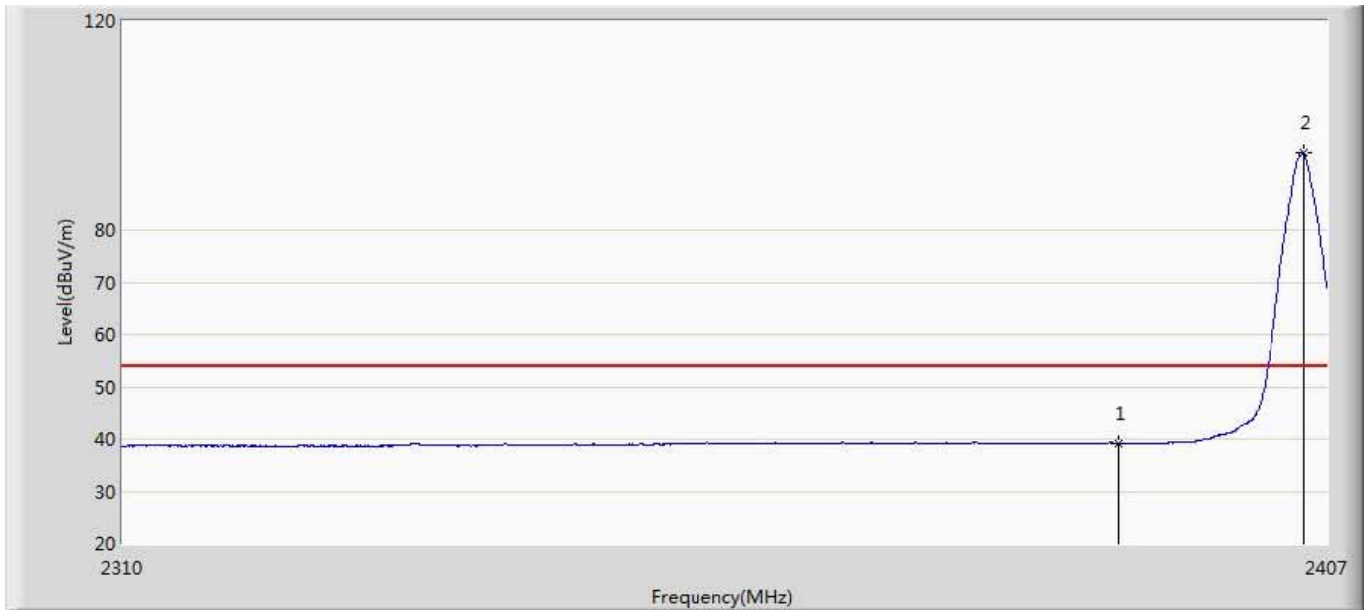

No	Mark	Frequency (MHz)	Measure Level (dBuV/m)	Reading Level (dBuV)	Over Limit (dB)	Limit (dBuV/m)	Factor (dB)	Type
1		2390.000	39.181	2.757	-14.819	54.000	36.424	AV
2	*	2405.108	94.728	58.341	N/A	N/A	36.387	AV

Engineer: Karl	
Site: AC5	Time: 2018/11/12 - 21:41
Limit: FCC_Part15.209_RE(3m)	Margin: 0
Probe: Horn_3117_00167055(1-18GHz)	Polarity: Horizontal
EUT: Lux BR30	Power: AC 120V/60Hz
Note: Mode 1:Transmit at 2405MHz by zigbee	

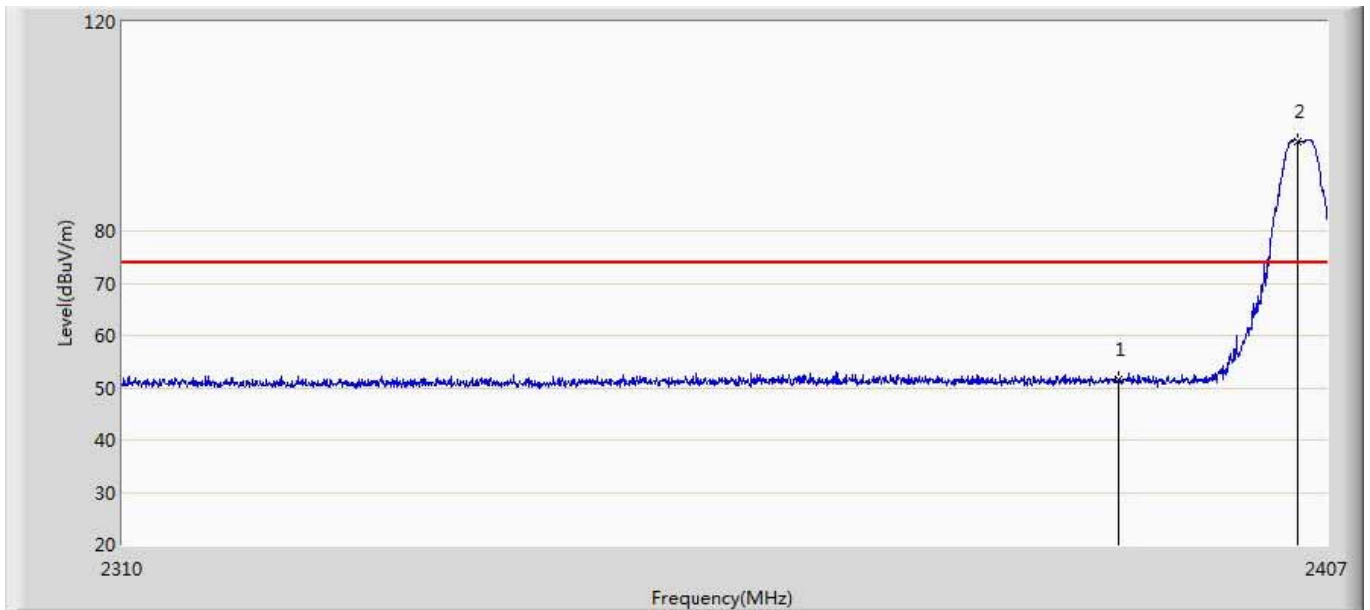

No	Mark	Frequency (MHz)	Measure Level (dBuV/m)	Reading Level (dBuV)	Over Limit (dB)	Limit (dBuV/m)	Factor (dB)	Type
1		2390.000	51.523	15.099	-22.477	74.000	36.424	PK
2	*	2404.624	97.239	60.851	N/A	N/A	36.388	PK

Engineer: Karl	
Site: AC5	Time: 2018/11/12 - 21:43
Limit: FCC_Part15.209_RE(3m)	Margin: 0
Probe: Horn_3117_00167055(1-18GHz)	Polarity: Vertical
EUT: Lux BR30	Power: AC 120V/60Hz
Note: Mode 1:Transmit at 2405MHz by zigbee	

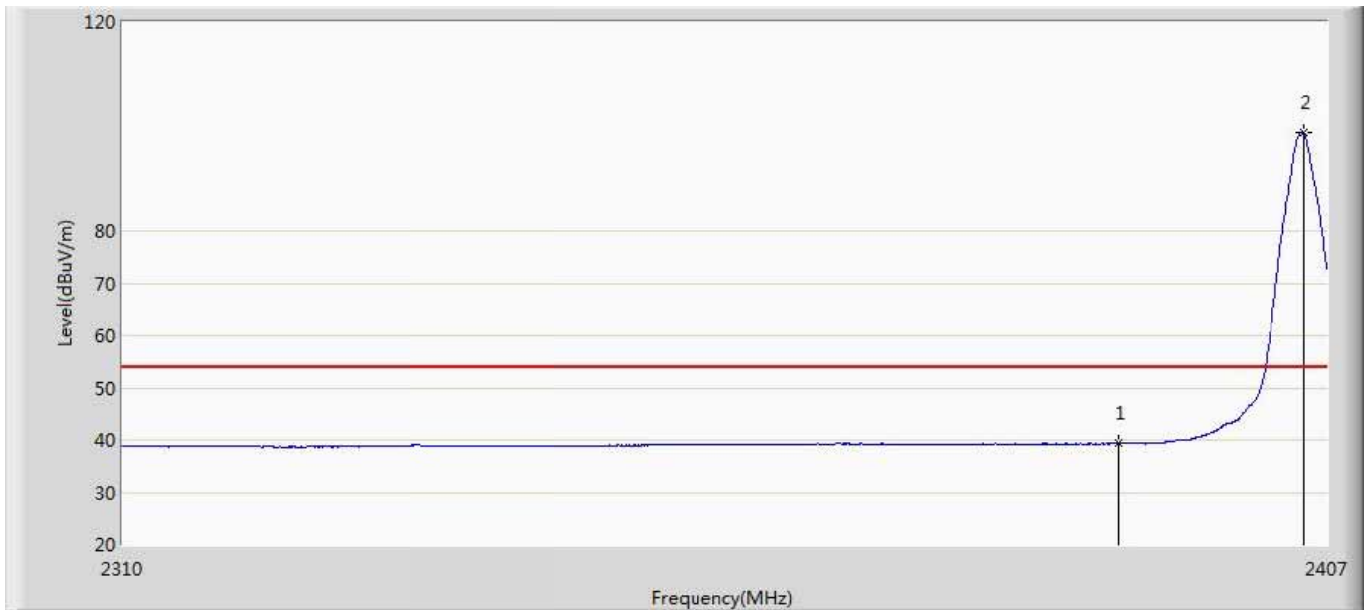

No	Mark	Frequency (MHz)	Measure Level (dBuV/m)	Reading Level (dBuV)	Over Limit (dB)	Limit (dBuV/m)	Factor (dB)	Type
1		2390.000	39.324	2.900	-14.676	54.000	36.424	AV
2	*	2405.108	98.876	62.489	N/A	N/A	36.387	AV

Engineer: Karl	
Site: AC5	Time: 2018/11/12 - 21:46
Limit: FCC_Part15.209_RE(3m)	Margin: 0
Probe: Horn_3117_00167055(1-18GHz)	Polarity: Vertical
EUT: Lux BR30	Power: AC 120V/60Hz
Note: Mode 1:Transmit at 2405MHz by zigbee	

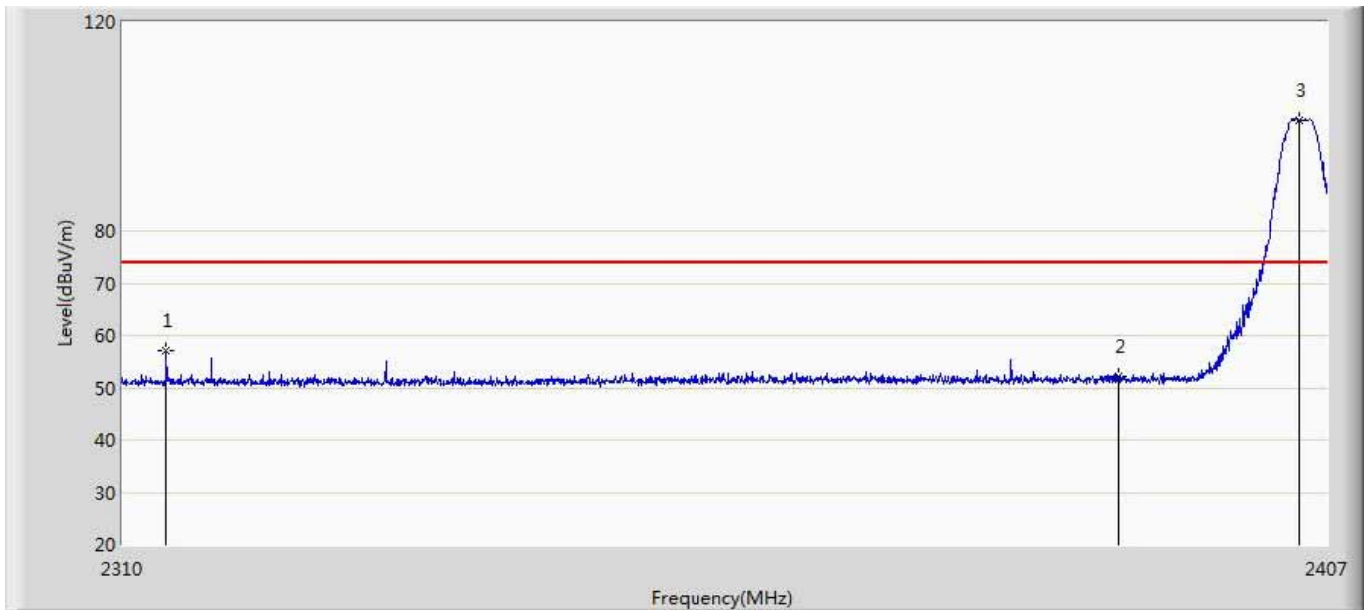

No	Mark	Frequency (MHz)	Measure Level (dBuV/m)	Reading Level (dBuV)	Over Limit (dB)	Limit (dBuV/m)	Factor (dB)	Type
1		2313.492	57.102	20.931	-16.898	74.000	36.171	PK
2		2390.000	52.090	15.666	-21.910	74.000	36.424	PK
3	*	2404.769	101.111	64.723	N/A	N/A	36.388	PK

Engineer: Karl	
Site: AC5	Time: 2018/11/12 - 21:49
Limit: FCC_Part15.209_RE(3m)	Margin: 0
Probe: Horn_3117_00167055(1-18GHz)	Polarity: Horizontal
EUT: Lux BR30	Power: AC 120V/60Hz
Note: Mode 1:Transmit at 2480MHz by zigbee	

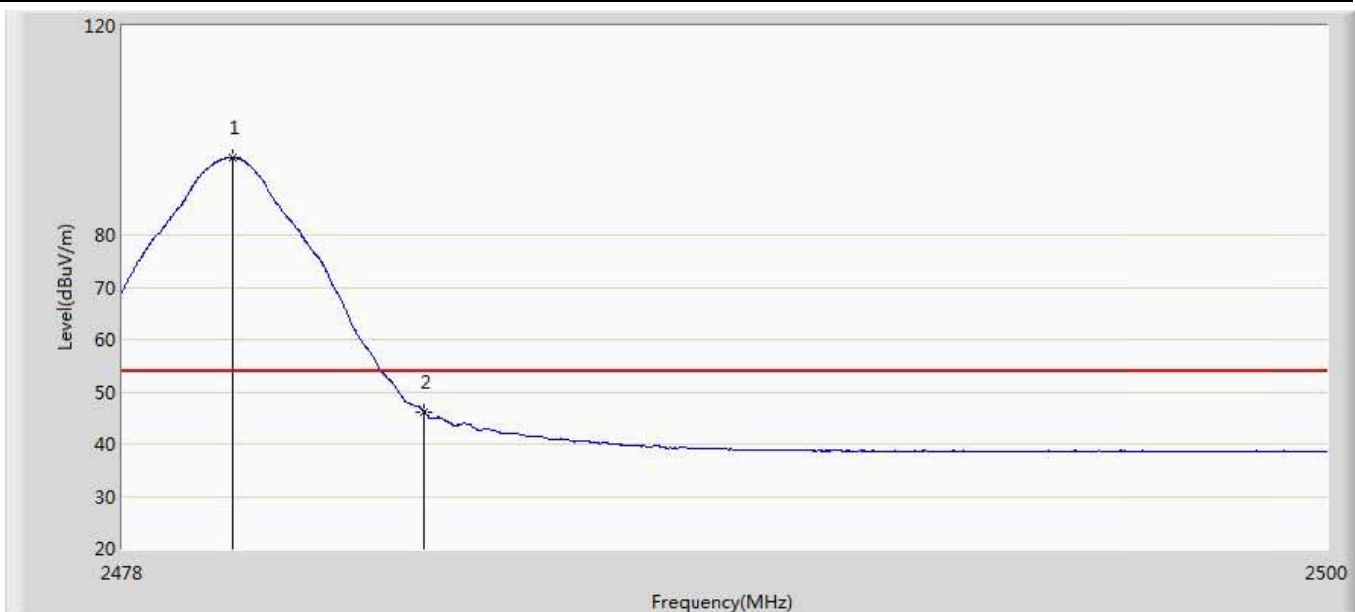

No	Mark	Frequency (MHz)	Measure Level (dBuV/m)	Reading Level (dBuV)	Over Limit (dB)	Limit (dBuV/m)	Factor (dB)	Type
1	*	2480.013	94.778	58.138	N/A	N/A	36.640	AV
2		2483.500	46.103	9.457	-7.897	54.000	36.646	AV

Engineer: Karl	
Site: AC5	Time: 2018/11/12 - 21:52
Limit: FCC_Part15.209_RE(3m)	Margin: 0
Probe: Horn_3117_00167055(1-18GHz)	Polarity: Horizontal
EUT: Lux BR30	Power: AC 120V/60Hz
Note: Mode 1:Transmit at 2480MHz by zigbee	

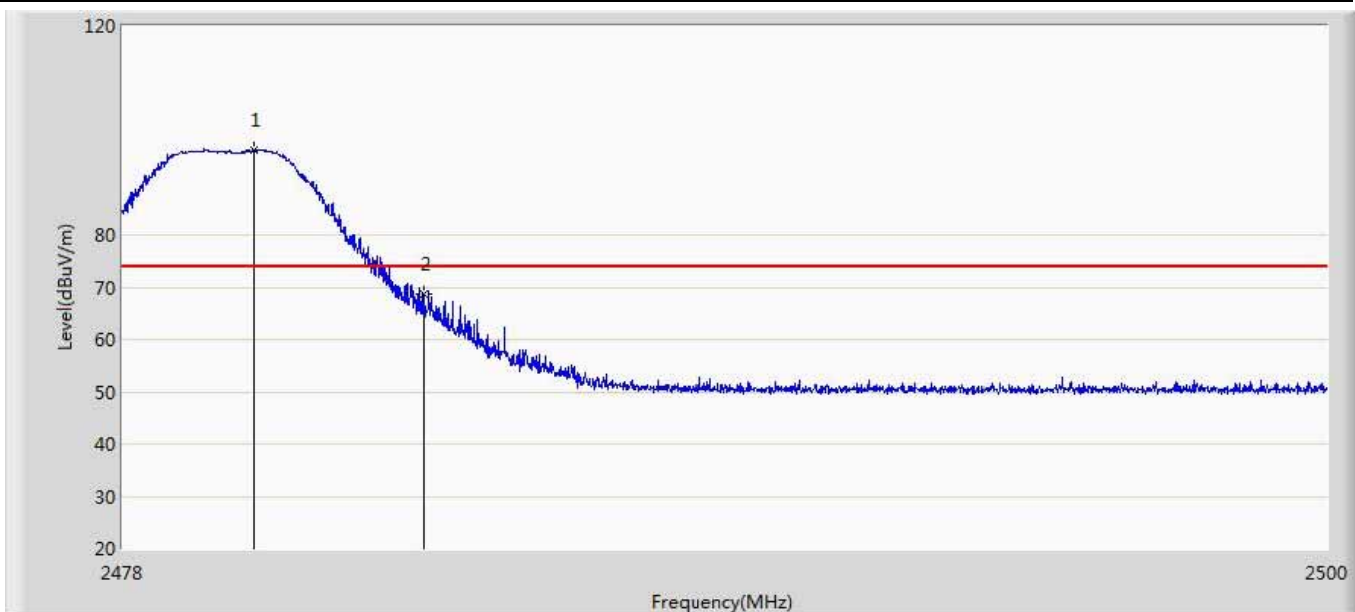

No	Mark	Frequency (MHz)	Measure Level (dBuV/m)	Reading Level (dBuV)	Over Limit (dB)	Limit (dBuV/m)	Factor (dB)	Type
1	*	2480.387	96.286	59.645	N/A	N/A	36.641	PK
2		2483.500	68.687	32.041	-5.313	74.000	36.646	PK

Engineer: Karl	
Site: AC5	Time: 2018/11/12 - 21:54
Limit: FCC_Part15.209_RE(3m)	Margin: 0
Probe: Horn_3117_00167055(1-18GHz)	Polarity: Vertical
EUT: Lux BR30	Power: AC 120V/60Hz
Note: Mode 1:Transmit at 2480MHz by zigbee	

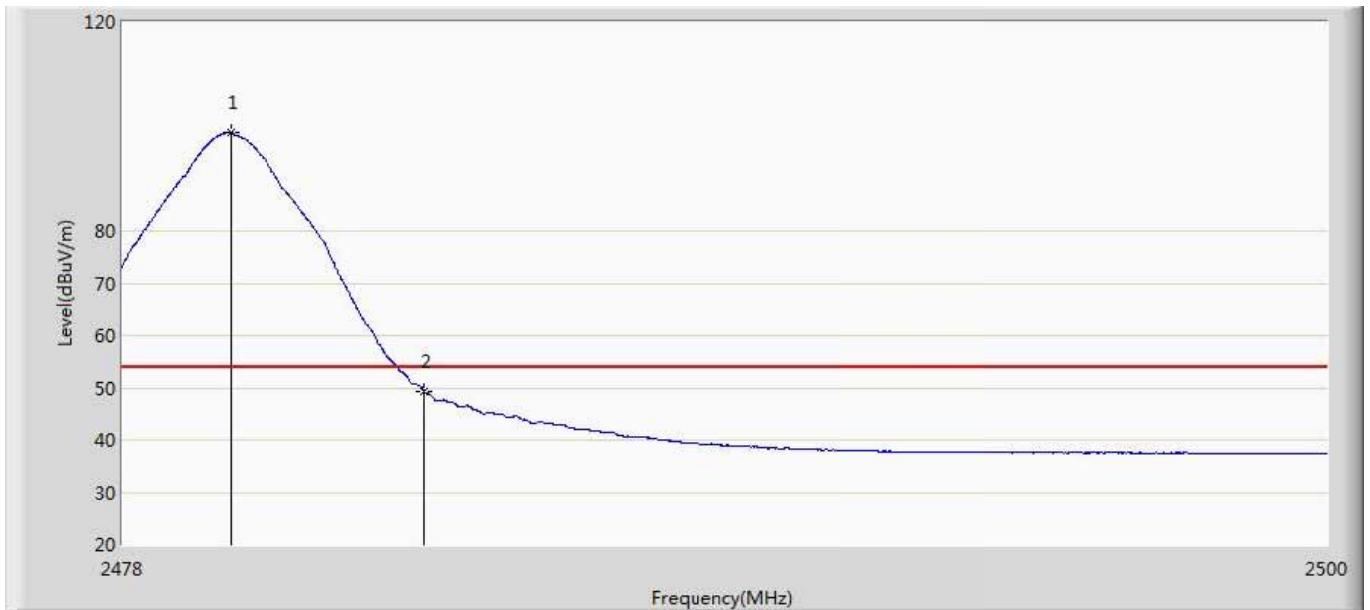

No	Mark	Frequency (MHz)	Measure Level (dBuV/m)	Reading Level (dBuV)	Over Limit (dB)	Limit (dBuV/m)	Factor (dB)	Type
1	*	2479.980	98.772	62.132	N/A	N/A	36.640	AV
2		2483.500	49.420	12.774	-4.580	54.000	36.646	AV

Engineer: Karl	
Site: AC5	Time: 2018/11/12 - 22:02
Limit: FCC_Part15.209_RE(3m)	Margin: 0
Probe: Horn_3117_00167055(1-18GHz)	Polarity: Vertical
EUT: Lux BR30	Power: AC 120V/60Hz
Note: Mode 1:Transmit at 2480MHz by zigbee	

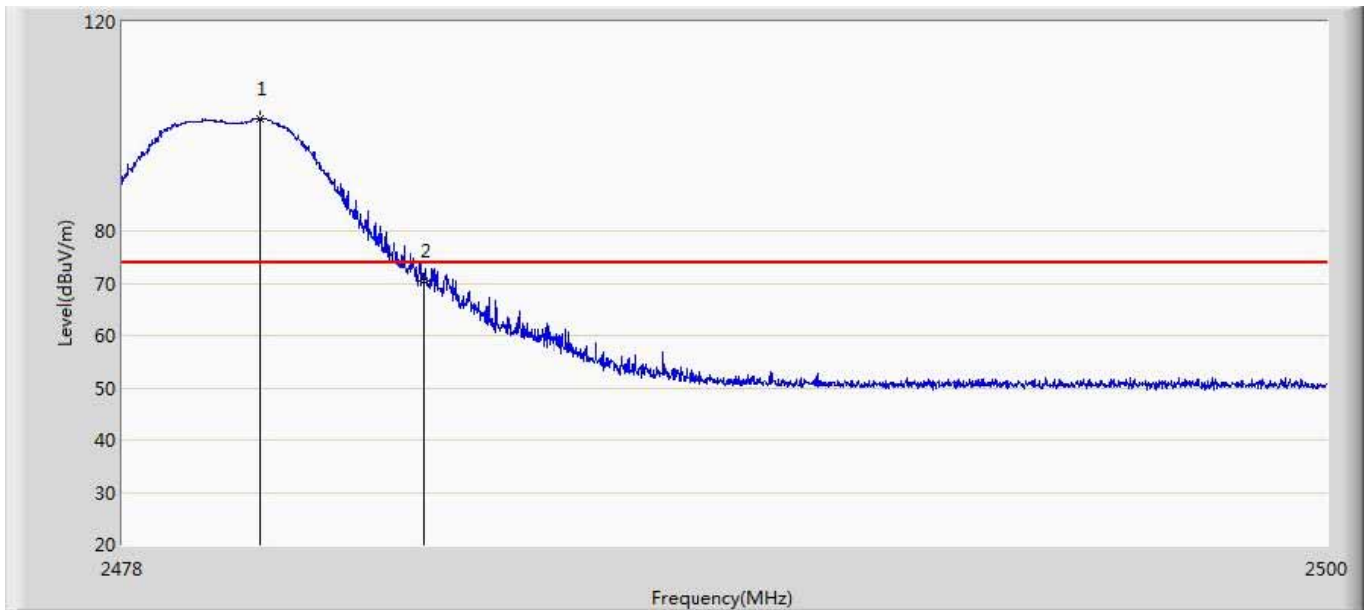

No	Mark	Frequency (MHz)	Measure Level (dBuV/m)	Reading Level (dBuV)	Over Limit (dB)	Limit (dBuV/m)	Factor (dB)	Type
1	*	2480.497	101.362	64.721	N/A	N/A	36.641	PK
2		2483.500	70.475	33.829	-3.525	74.000	36.646	PK

7. Occupied Bandwidth

7.1. Test Equipment

Occupied Bandwidth / TR-8					
Instrument	Manufacturer	Type No.	Serial No.	Cal. Date	Cal. Due Date
Spectrum Analyzer	Agilent	N9010A	MY48030494	2018.02.04	2019.01.15
EXA Spectrum Analyzer	Keysight	N9010A	MY55370495	2018.04.09	2019.04.08
MXA Signal Analyzer	Keysight	N9020A	MY56060147	2018.04.09	2019.04.08
Temperature/Humidity Meter	zhichen	ZC1-2	TR8-TH	2018.04.10	2019.04.09

Note: All equipments are calibrated with traceable calibrations. Each calibration is traceable to the national or international standards.

7.2. Test Setup

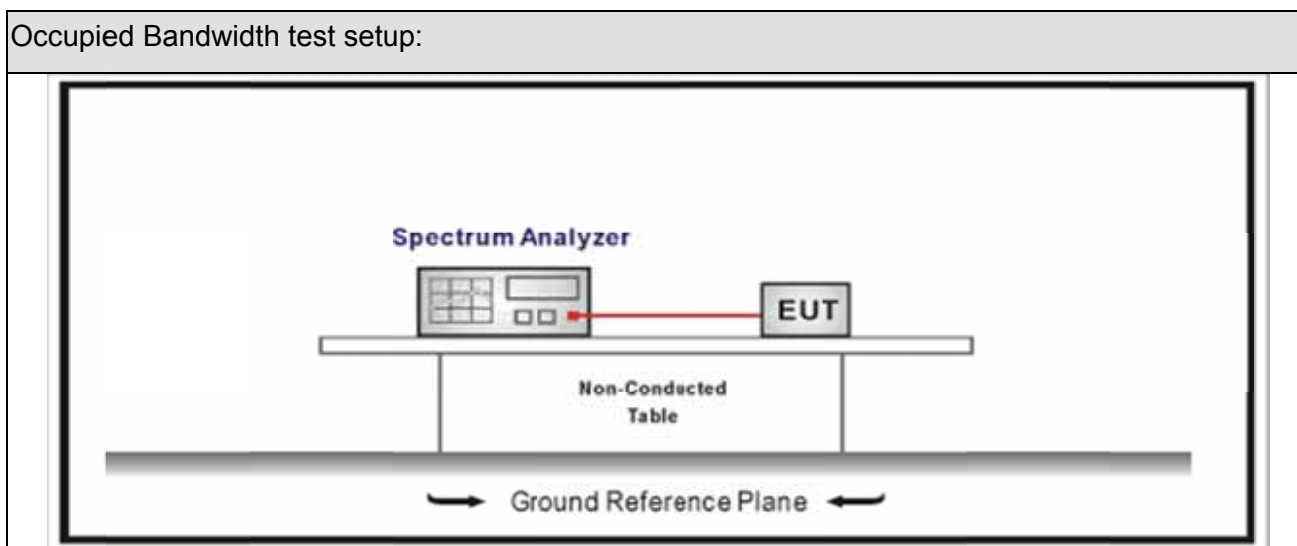



7.3. Limit

Occupied Bandwidth
Systems using digital modulation techniques operate in the 2400-2483.5 MHz. The minimum 6 dB bandwidth shall be at least 500 kHz

7.4. Test Procedure

Test Method			
	Reference Rule	Chapter	Description
<input checked="" type="checkbox"/>	ANSI C63.10	11.8	DTS bandwidth
	<input type="checkbox"/> ANSI C63.10	11.8.1	Option 1
	<input checked="" type="checkbox"/> ANSI C63.10	11.8.2	Option 2

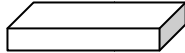
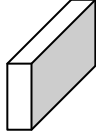
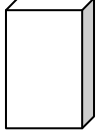
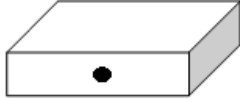
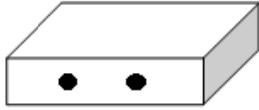
7.5. EUT test definition

Item	Occupied Bandwidth			
Device Category	<input type="checkbox"/>	Fixed point-to-point		
	<input type="checkbox"/>	Emit multiple directional beams, simultaneously or sequentially		
	<input checked="" type="checkbox"/>	Other cases		
Test mode	Mode 1			
Test method	<input type="checkbox"/>	Radiated		
		X Axis	Y Axis	Z Axis
				
		Worst Axis <input type="checkbox"/>	Worst Axis <input type="checkbox"/>	Worst Axis <input type="checkbox"/>
	<input checked="" type="checkbox"/>	Conducted		
	<input checked="" type="checkbox"/>	Chain 0		
				
	<input type="checkbox"/>	Chain 0	Chain 1	
				
	<input type="checkbox"/>	Chain 0	Chain 1	Chain 2
				

7.6. Test Result

Product Name	: LED lamp	Power	: AC 120V/60Hz
Test Mode	: Mode 1	Test Site	: TR-8
Test Date	: 2018.09.13		

Mode	CH.	Test Freq. (MHz)	99% Occupied Bandwidth (kHz)	6dB Occupied Bandwidth (kHz)	Limit (kHz)	Result
1	11	2405	2273.8	1722	>500	Pass
1	15	2425	2297.6	1661	>500	Pass
1	20	2450	2306.7	1709	>500	Pass
1	25	2475	2303.4	1715	>500	Pass
1	26	2480	2289.7	1753	>500	Pass

Note : The worst case of Occupied Bandwidth as below:

Mode 1 CH15 (2425MHz)



8. Fundamental emission output power

8.1. Test Equipment

Fundamental emission output power/ TR-8					
Instrument	Manufacturer	Type No.	Serial No.	Cal. Date	Cal. Due Date
Spectrum Analyzer	Agilent	E4446A	MY45300103	2018.01.04	2019.01.03
Spectrum Analyzer	Agilent	N9010A	MY48030494	2018.02.04	2019.01.15
Wideband Peak Power Meter	Anritsu	ML2495A	0905006	2018.10.14	2019.10.13
Power Sensor	Anritsu	MA2411B	0846014	2018.10.14	2019.10.13
Temperature/Humidity Meter	zhicheng	ZC1-2	TR8-TH	2018.04.10	2019.04.09

Note: All equipments are calibrated with traceable calibrations. Each calibration is traceable to the national or international standards.

8.2. Test Setup

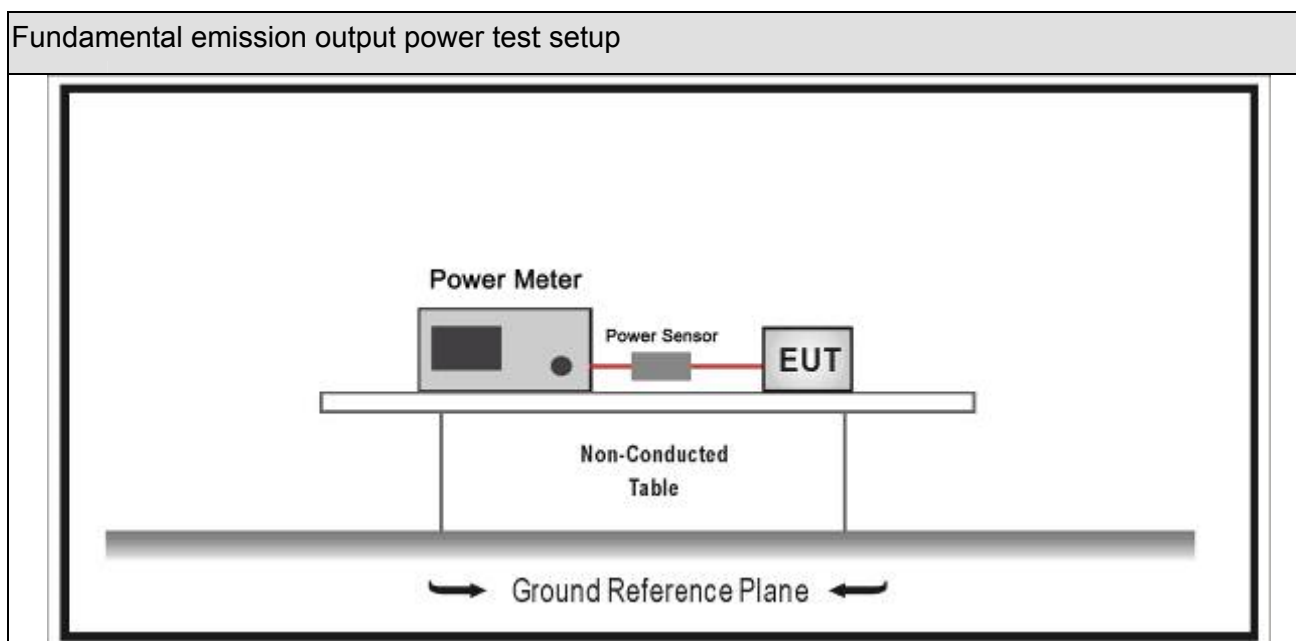



8.3. Limit

Fundamental emission output power Limit		
<input checked="" type="checkbox"/>	$G_{TX} < 6\text{dBi}$	$P_{out} \leq 30\text{dBm}$
<input type="checkbox"/>	$G_{TX} > 6\text{dBi}$	
<input type="checkbox"/>	Non-Fix point-point	$P_{out} \leq 30 - (G_{TX} - 6)$
<input type="checkbox"/>	Fix point-point	$P_{out} \leq 30 - [(G_{TX} - 6)]/3$
<input type="checkbox"/>	Point-to-multipoint	$P_{out} \leq 30 - (G_{TX} - 6)$
<input type="checkbox"/>	Overlap Beams	$P_{out} \leq 30 - [(G_{TX} - 6)]/3$
<input type="checkbox"/>	Aggregate power transmitted simultaneously on all beams	$P_{out} \leq 30 - [(G_{TX} - 6)]/3$
<input type="checkbox"/>	single directional beam	$P_{out} \leq 30 - [(G_{TX} - 6)]/3 + 8\text{dB}$
<p>Note 1 : G_{TX} directional gain of transmitting antennas.</p> <p>Note 2 : P_{out} is maximum peak conducted output power .</p>		

8.4. Test Procedure

Fundamental emission output power Test Method					
	References Rule		Chapter	Description	
<input checked="" type="checkbox"/>	ANSI C63.10		11.9	Fundamental emission output power	
	<input checked="" type="checkbox"/>	ANSI C63.10		11.9.1	Maximum peak conducted output power
	<input type="checkbox"/>	ANSI C63.10	11.9.1.1	RBW ≥ DTS bandwidth	
	<input type="checkbox"/>	ANSI C63.10	11.9.1.2	Integrated band power method	
	<input checked="" type="checkbox"/>	ANSI C63.10	11.9.1.3	PKPM1 Peak power meter method	
	<input checked="" type="checkbox"/>	ANSI C63.10		11.9.2	Maximum conducted (average) output power
	<input type="checkbox"/>	ANSI C63.10		11.9.2.2	Measurement using a spectrum analyzer (SA)
	<input type="checkbox"/>	ANSI C63.10	11.9.2.2.2	Method AVGSA-1(Duty cycle 98%)	
	<input type="checkbox"/>	ANSI C63.10	11.9.2.2.3	Method AVGSA-1A(Duty cycle 98%)	
	<input type="checkbox"/>	ANSI C63.10	11.9.2.2.4	Method AVGSA-2(Duty cycle 98%)	
	<input type="checkbox"/>	ANSI C63.10	11.9.2.2.5	Method AVGSA-2A(Duty cycle 98%)	
	<input type="checkbox"/>	ANSI C63.10	11.9.2.2.4	Method AVGSA-3	
	<input type="checkbox"/>	ANSI C63.10	11.9.2.2.5	Method AVGSA-3A	
	<input checked="" type="checkbox"/>	ANSI C63.10		11.9.2.3	Measurement using a power meter (PM)
	<input checked="" type="checkbox"/>	ANSI C63.10	11.9.2.3.1	Method AVGPM	
<input type="checkbox"/>	ANSI C63.10	11.9.2.3.2	Method AVGPM-G		

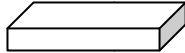
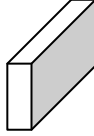
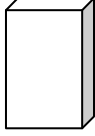
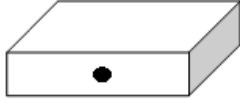
8.5. EUT test definition

Item	Fundamental emission output power			
Device Category	<input type="checkbox"/>	Fixed point-to-point		
	<input type="checkbox"/>	Emit multiple directional beams, simultaneously or sequentially		
	<input checked="" type="checkbox"/>	Other cases		
Test mode	Mode 1			
Test method	<input type="checkbox"/>	Radiated		
		X Axis	Y Axis	Z Axis
				
		Worst Axis <input type="checkbox"/>	Worst Axis <input type="checkbox"/>	Worst Axis <input type="checkbox"/>
	<input checked="" type="checkbox"/>	Conducted		
	<input checked="" type="checkbox"/>	Chain 0		
				
	<input type="checkbox"/>	Chain 0	Chain 1	
				
	<input type="checkbox"/>	Chain 0	Chain 1	Chain 2
				

8.6. Test Result

Product Name	: LED lamp	Power	: AC 120V/60Hz
Test Mode	: Mode 1	Test Site	: TR-8
Test Date	: 2018.09.16		

Diode (FL3840023)_2017:

Mode	Channel	Test Frequency (MHz)	Measurement Power Output (dBm)	Limit (dBm)	Result
1	11	2405	9.45	30	Pass
1	15	2425	9.28	30	Pass
1	20	2450	9.21	30	Pass
1	25	2475	8.99	30	Pass
1	26	2480	8.86	30	Pass

Murata (XRCGB38M400FXH17R0):

Mode	Channel	Test Frequency (MHz)	Measurement Power Output (dBm)	Limit (dBm)	Result
1	11	2405	9.77	30	Pass
1	15	2425	9.63	30	Pass
1	20	2450	9.28	30	Pass
1	25	2475	8.99	30	Pass
1	26	2480	8.95	30	Pass

9. Power Spectral Density

9.1. Test Equipment

Power Spectral Density / TR-8					
Instrument	Manufacturer	Type No.	Serial No.	Cal. Date	Cal. Due Date
Spectrum Analyzer	Agilent	N9010A	MY48030494	2018.02.04	2019.01.15
EXA Spectrum Analyzer	Keysight	N9010A	MY55370495	2018.04.09	2019.04.08
MXA Signal Analyzer	Keysight	N9020A	MY56060147	2018.04.09	2019.04.08
Temperature/Humidity Meter	zhichen	ZC1-2	TR8-TH	2018.04.10	2019.04.09

Note: All equipments are calibrated with traceable calibrations. Each calibration is traceable to the national or international standards.

9.2. Test Setup

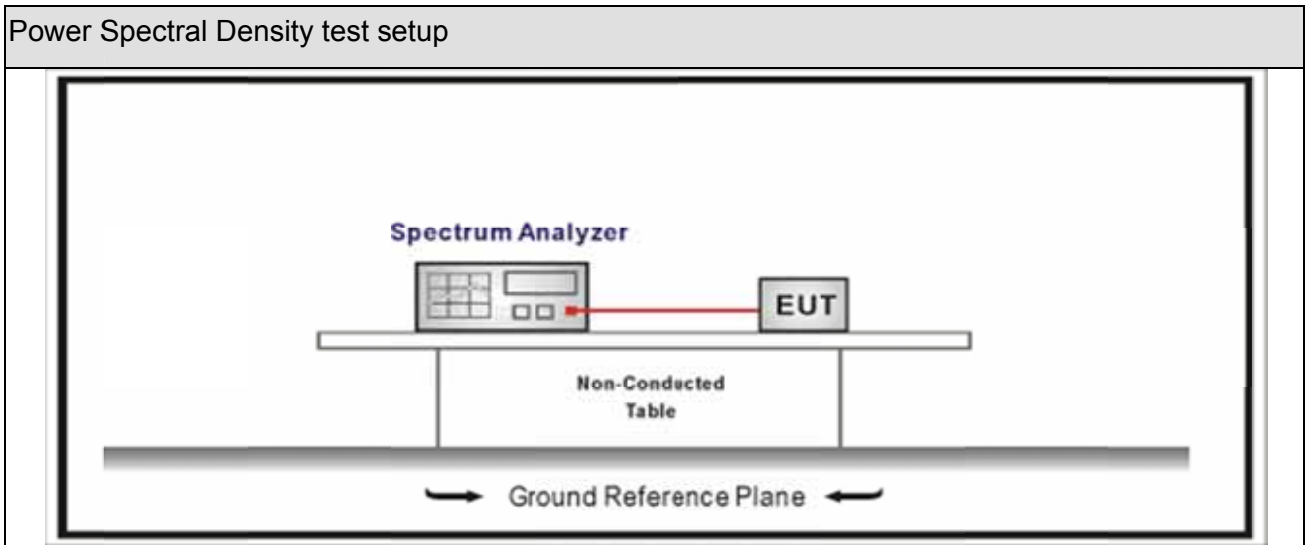



9.3. Limit

Power Spectral Density Limit
Power Spectral Density 8dBm/3kHz

9.4. Test Procedure

Power Spectral Density Test Method			
	References Rule	Chapter	Description
<input checked="" type="checkbox"/>	ANSI C63.10	11.10	Maximum power spectral density level in the fundamental emission
<input checked="" type="checkbox"/>	ANSI C63.10	11.10.2	Method PKPSD (peak PSD)
<input type="checkbox"/>	ANSI C63.10	11.10.3	Method AVGPSD-1(Duty cycle 98%)
<input type="checkbox"/>	ANSI C63.10	11.10.4	Method AVGPSD-1A(Duty cycle 98%)
<input type="checkbox"/>	ANSI C63.10	11.10.5	Method AVGPSD-2(Duty cycle < 98%)
<input type="checkbox"/>	ANSI C63.10	11.10.6	Method AVGPSD-2A(Duty cycle < 98%)
<input type="checkbox"/>	ANSI C63.10	11.10.7	Method AVGPSD-3
<input type="checkbox"/>	ANSI C63.10	11.10.8	Method AVGPSD-3A

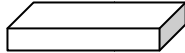
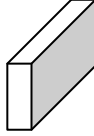
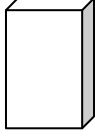
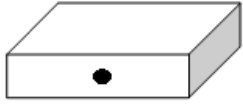
9.5. EUT test definition

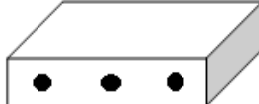
Item	Power Spectral Density Test Method			
Device Category	<input type="checkbox"/>	Fixed point-to-point		
	<input type="checkbox"/>	Emit multiple directional beams, simultaneously or sequentially		
	<input checked="" type="checkbox"/>	Other cases		
Test mode	Mode 1			
Test method	<input type="checkbox"/>	Radiated		
		X Axis	Y Axis	Z Axis
				
		Worst Axis <input type="checkbox"/>	Worst Axis <input type="checkbox"/>	Worst Axis <input type="checkbox"/>
	<input checked="" type="checkbox"/>	Conducted		
	<input checked="" type="checkbox"/>	Chain 0		
				
	<input type="checkbox"/>	Chain 0	Chain 1	
				
	<input type="checkbox"/>	Chain 0	Chain 1	Chain 2
				

9.6. Test Result

Product Name	: LED lamp	Power	: AC 120V/60Hz
Test Mode	: Mode 1	Test Site	: TR-8
Test Date	: 2018.09.17		

Mode	Channel	Test Frequency (MHz)	Measurement PSD (dBm/3kHz)	Total PSD (dBm/3kHz)	Limit (dBm/3kHz)	Result
1	11	2405	-6.128	-6.128	8	Pass
1	15	2425	-6.545	-6.545	8	Pass
1	20	2450	-6.508	-6.508	8	Pass
1	25	2475	-6.274	-6.274	8	Pass
1	26	2480	-6.127	-6.127	8	Pass

Note : The worst case of Power Spectral Density as below:

Mode 1 CH26(2480MHz)



10. Antenna Requirement

10.1. Limit

Antenna Requirement Limit
<p>An intentional radiator shall be designed to ensure that no antenna other than that furnished by the responsible party shall be used with the device. The use of a permanently attached antenna or of an antenna that uses a unique coupling to the intentional radiator shall be considered sufficient to comply with the provisions of this section. The manufacturer may design the unit so that a broken antenna can be replaced by the user, but the use of a standard antenna jack or electrical connector is prohibited. This requirement does not apply to carrier current devices or to devices operated under the provisions of §15.211, §15.213, §15.217, §15.219, or §15.221. Further, this requirement does not apply to intentional radiators that must be professionally installed, such as perimeter protection systems and some field disturbance sensors, or to other intentional radiators which, in accordance with §15.31(d), must be measured at the installation site. However, the installer shall be responsible for ensuring that the proper antenna is employed so that the limits in this part are not exceeded.</p>

10.2. Antenna Connector Construction

Antenna Connector Construction	
<input checked="" type="checkbox"/>	The use of a permanently attached antenna
<input type="checkbox"/>	The antenna use of a unique coupling to the intentional radiator
<input type="checkbox"/>	The use of a nonstandard antenna jack or electrical connector
Please refer to the attached document "Internal Photograph" to show the antenna connector.	

_____ The End _____