



# Test Report

## FCC Part15 Subpart C & ISED RSS-247 Issue 2

Product Name : Hue Outdoor Lightstrip 5m  
Model No. : 9290018186A  
FCC ID : 2AGBW9290018186AX  
IC : 20812-8186AX

Applicant : Philips Lighting (China) Investment Co., Ltd.  
Address : Building 9, Lane 888, Tianlin Road, Minhang district,  
Shanghai, China

Date of Receipt : May. 07, 2018  
Test Date : May. 07, 2018~ Jun. 13, 2018  
Issued Date : Aug. 07, 2018  
Report No. : 1852048R-RF-US-P06V02  
Report Version : V1.0

The test results relate only to the samples tested.

The test results shown in the test report are traceable to the national/international standard through the calibration of the equipment and evaluated measurement uncertainty herein.

This report must not be used to claim product endorsement by TAF, A2LA or any agency of the government.

The test report shall not be reproduced without the written approval of DEKRA Testing & Certification (Suzhou) Co., Ltd.

# Test Report Certification

Issued Date : Aug. 07, 2018  
Report No. : 1852048R-RF-US-P06V02



Product Name : Hue Outdoor Lightstrip 5m  
 Applicant : Philips Lighting (China) Investment Co., Ltd.  
 Address : Building 9, Lane 888, Tianlin Road, Minhang district, Shanghai, China  
 Manufacturer : Philips Lighting (China) Investment Co., Ltd.  
 Address : Building 9, Lane 888, Tianlin Road, Minhang district, Shanghai, China  
 Model No. : 9290018186A  
 FCC ID : 2AGBW9290018186AX  
 IC : 20812-8186AX  
 Brand Name : Philips  
 EUT Voltage : 100 ~ 120Vac, 50-60Hz; 1000mA; Max. 49W  
 Test Voltage : AC 120V/60Hz  
 Applicable Standard : FCC CFR Title 47 Part 15 Subpart C  
 ANSI C63.10:2013  
 KDB 558074 D01v04  
 ISED RSS-Gen Issue 5 / RSS-247 Issue 2  
 Test Result : Complied  
 Performed Location : DEKRA Testing & Certification (Suzhou) Co., Ltd.  
 No.99 Hongye Rd., Suzhou Industrial Park, Suzhou, 215006, Jiangsu, China  
 TEL: +86-512-6251-5088 / FAX: +86-512-6251-5098  
 FCC Designation Number: CN1199; IC Lab Code: 4075B

Documented By : Kathy Feng  
 (Project Assistant: Kathy Feng)

Reviewed By : Frank He  
 (Senior Project Manager: Frank He )

Approved By : Harry Zhao  
 (Engineering Manager: Harry Zhao )

## TABLE OF CONTENTS

Description	Page
1. General Information.....	6
1.1. EUT Description.....	6
1.2. Working Frequency of Each Channel:.....	6
1.3. Antenna information.....	7
1.4. Mode of Operation.....	8
1.5. Tested System Details.....	8
1.6. Configuration of Tested System.....	9
1.7. EUT Exercise Software.....	10
2. Technical Test.....	11
2.1. Summary of Test Result.....	11
2.2. Test Environment.....	13
2.3. Measurement Uncertainty.....	13
3. AC Power Line Conducted Emission.....	14
3.1. Test Equipment.....	14
3.2. Test Setup.....	14
3.3. Limit.....	15
3.4. Test Procedure.....	15
3.5. Test Result.....	16
4. Emissions in restricted frequency bands.....	19
4.1. Test Equipment.....	19
4.2. Test Setup.....	20
4.3. Limit.....	21
4.4. Test Procedure.....	24
4.5. EUT test Axis definition.....	25
4.6. Test Result.....	26
5. Emissions in non-restricted frequency bands.....	34
5.1. Test Equipment.....	34
5.2. Test Setup.....	34
5.3. Limit.....	35
5.4. Test Procedure.....	36
5.5. EUT test Axis definition.....	37
5.6. Test Result.....	38
6. Radiated Emission Band Edge.....	39
6.1. Test Equipment.....	39
6.2. Test Setup.....	40
6.3. Limit.....	40
6.4. Test Procedure.....	41

- 6.5. EUT test definition..... 42
- 6.6. Duty Cycle.....43
- 6.7 Test Result.....44
- 7. Occupied Bandwidth..... 52
- 7.1. Test Equipment..... 52
- 7.2. Test Setup..... 52
- 7.3. Limit..... 53
- 7.4. Test Procedure..... 53
- 7.5. EUT test definition..... 54
- 7.6. Test Result..... 55
- 8. Fundamental emission output power..... 56
- 8.1. Test Equipment..... 56
- 8.2. Test Setup..... 56
- 8.3. Limit..... 57
- 8.4. Test Procedure..... 58
- 8.5. EUT test definition..... 59
- 8.6. Test Result..... 60
- 9. Power Spectral Density..... 61
- 9.1. Test Equipment..... 61
- 9.2. Test Setup..... 61
- 9.3. Limit..... 61
- 9.4. Test Procedure..... 62
- 9.5. EUT test definition..... 63
- 9.6. Test Result..... 64
- 10. Antenna Requirement..... 65
- 10.1. Limit..... 65
- 10.2. Antenna Connector Construction.....65

### History of This Test Report

REPORT NO.	VERSION	DESCRIPTION	ISSUED DATE
1852048R-RF-US-P06V02	V1.0	Initial Issued Report	Aug. 07, 2018

**1. General Information**

**1.1. EUT Description**

Product Name	Hue Outdoor Lightstrip 5m
Brand Name	Philips
Model No.	9290018186A
EUT Voltage	100 ~ 120Vac, 50-60Hz; 1000mA; Max. 49W
Frequency Range	2405 ~ 2480MHz
Channel Number	16
Type of Modulation	O-QPSK
Data Rate	250kbps
Antenna Type	Reference to Antenna List
Peak Antenna Gain	Reference to Antenna List

**1.2. Working Frequency of Each Channel:**

Zigbee Working Frequency of Each Channel:							
Channel	Frequency	Channel	Frequency	Channel	Frequency	Channel	Frequency
11	2405 MHz	12	2410 MHz	13	2415 MHz	14	2420 MHz
15	2425 MHz	16	2430 MHz	17	2435 MHz	18	2440 MHz
19	2445 MHz	20	2450 MHz	21	2455 MHz	22	2460 MHz
23	2465 MHz	24	2470 MHz	25	2475 MHz	26	2480 MHz

### 1.3. Antenna information

Antenna manufacturer	N/A		
Antenna Delivery	<input checked="" type="checkbox"/> 1*TX+1*RX	<input type="checkbox"/> 2*TX+2*RX	<input type="checkbox"/> 3*TX+3*RX
Antenna technology	<input checked="" type="checkbox"/> SISO		
	<input type="checkbox"/> MIMO	<input type="checkbox"/> Basic	
		<input type="checkbox"/> CDD	
		<input type="checkbox"/> Beam-forming	
Antenna Type	<input type="checkbox"/> External	<input type="checkbox"/> Dipole	
	<input checked="" type="checkbox"/> Internal	<input type="checkbox"/> PIFA	
		<input checked="" type="checkbox"/> PCB	
		<input type="checkbox"/> Ceramic Chip Antenna	
		<input type="checkbox"/> Metal plate type F antenna	
Antenna Gain	6.19dBi		

### 1.4. Mode of Operation

DEKRA has verified the construction and function in typical operation. See the different modes shown in this test report and defined as:

Test Modes List
Mode 1: Transmit by Zigbee

### 1.5. Tested System Details

The types for all equipment, plus descriptions of all cables used in the tested system (including inserted cards) are:

No.	Product	Manufacturer	Model No.	Serial No.	Power Cord
1	Notebook	Think Pad	2526	LV-A3285	Power by adapter
A	USB Control Cable	N/A	N/A	N/A	Shield, 1m
B	USB Control Cable	N/A	N/A	N/A	Shield, 10m



### 1.6. Configuration of Tested System

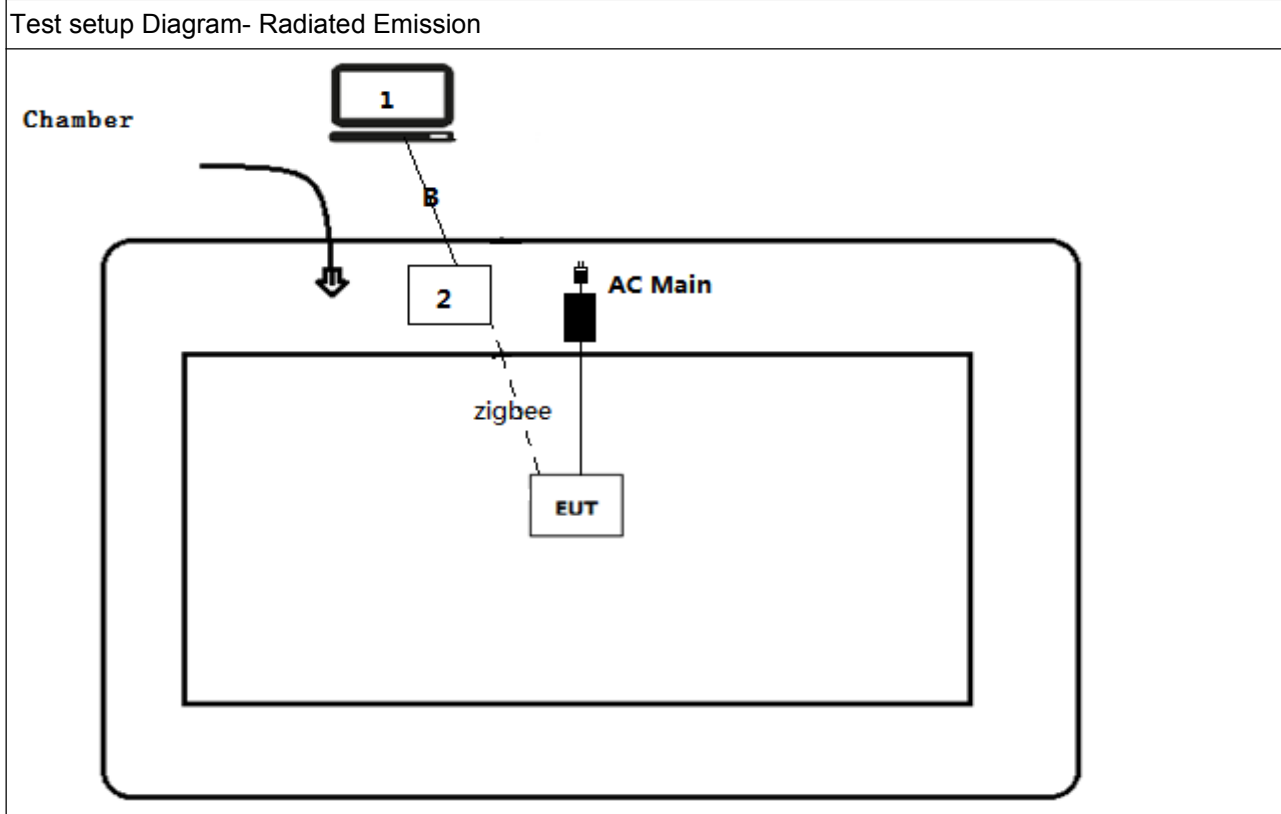
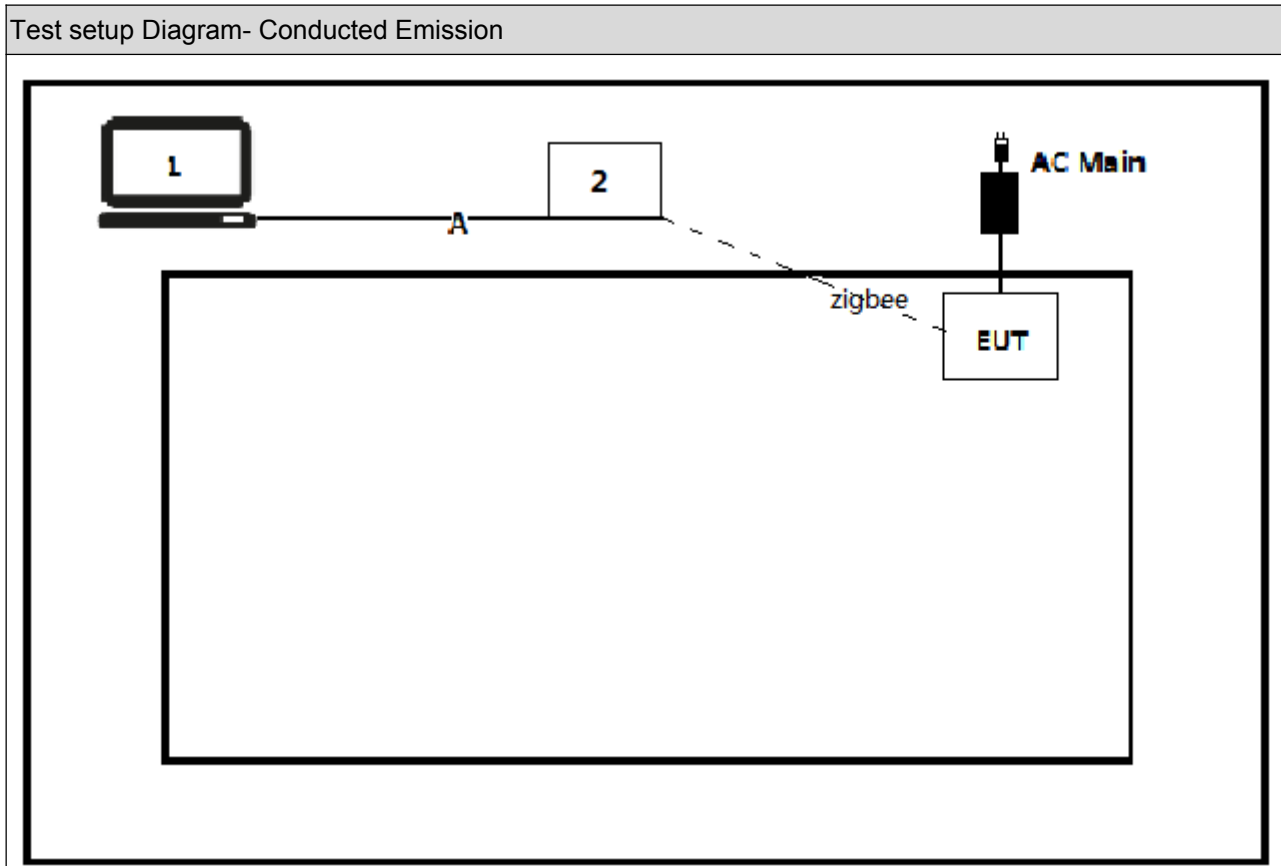

### 1.7. EUT Exercise Software

1	Setup the EUT and simulators as shown on above.
2	Turn on the power of all equipment.
3	Select the test mode and channel, then start continue Tx.

## 2. Technical Test

### 2.1. Summary of Test Result

#### For FCC rule:

Performed Test Item	Normative References	Limit	Result
AC Power Line Conducted Emission	FCC CFR Title 47 Part 15 Subpart C Section 15.207	FCC 15.207	PASS
Emissions in restricted frequency bands	FCC CFR Title 47 Part 15 Subpart C Section 15.209	FCC 15.209	PASS
Emissions in non-restricted frequency bands	FCC CFR Title 47 Part 15 Subpart C Section 15.247(d)	$\geq 20\text{dBc}$	PASS
Radiated Emission Band Edge	FCC CFR Title 47 Part 15 Subpart C 15.247(d)	FCC 15.209	PASS
Occupied Bandwidth	FCC CFR Title 47 Part 15 Subpart C Section 15.247(a)(2)	$\geq 500\text{kHz}$	PASS
Fundamental emission output power	FCC CFR Title 47 Part 15 Subpart C Section 15.247(b)(3)	$\leq 30\text{dBm}$	PASS
Power Spectral Density	FCC CFR Title 47 Part 15 Subpart C Section 15.247(e)	$\leq 8\text{dBm}/3\text{kHz}$	PASS
Antenna Requirement	FCC CFR Title 47 Part 15 Subpart C Section 15.203	FCC 15.203	PASS

**For IC rule:**

Performed Test Item	Normative References	Limit	Result
AC Power Line Conducted Emission	RSS-Gen Issue 5 Section 8.8	RSS-Gen	PASS
Emissions in restricted frequency bands	RSS-Gen Issue 5 Section 8.10	RSS-Gen	PASS
Emissions in non-restricted frequency bands	RSS-247 Issue 2 Section A5.5	$\geq 20\text{dBc}$	PASS
Radiated Emission Band Edge	RSS-247 Issue 2 Section A5.5	RSS-247	PASS
Occupied Bandwidth	RSS-Gen Issue 5 Section 6.7 RSS-247 Issue 2 Section A5.2(1)	$\geq 500\text{kHz}$	PASS
Fundamental emission output power	RSS-247 Issue 2 Section A5.4(4)	$\leq 30\text{dBm}$	PASS
Power Spectral Density	RSS-247 Issue 2 Section A5.2(2)	$\leq 8\text{dBm}/3\text{kHz}$	PASS
Antenna Requirement	RSS-Gen Issue 5 Section 6.8	RSS-Gen	PASS

## 2.2. Test Environment

Items	Required (IEC 68-1)	Actual
Temperature (°C)	15-35	21
Humidity (%RH)	25-75	50
Barometric pressure (mbar)	860-1060	950-1000

## 2.3. Measurement Uncertainty

Test Items	Uncertainty
AC Power Line Conducted Emission	$\pm 2.02\text{dB}$
Radiated Emission	Below 1GHz $\pm 3.8\text{ dB}$
	Above 1GHz $\pm 3.9\text{ dB}$
RF Antenna Port Conducted Emission	$\pm 1.27\text{dB}$
Radiated Emission Band Edge	$\pm 3.9\text{dB}$
Occupied Bandwidth	$\pm 1\text{kHz}$
Power Spectral Density	$\pm 1.27\text{dB}$

### 3. AC Power Line Conducted Emission

#### 3.1. Test Equipment

AC Power Line Conducted Emission / TR-1				
Instrument	Manufacturer	Type No.	Serial No.	Cal. Due Date
EMI Test Receiver	R&S	ESCI	100906	2019.03.04
Two-Line V-Network	R&S	ENV 216	101189	2018.07.15
Two-Line V-Network	R&S	ENV 216	101044	2018.09.15
50ohm Coaxial Switch	Anritsu	MP59B	6200464462	N/A
50ohm Termination	SHX	TF2	07081402	2018.09.15
Temperature/Humidity Meter	Zhichen	ZC1-2	TR1-TH	2019.01.03

Note: All equipment are calibrated with traceable calibrations. Each calibration is traceable to the national or international standards.

#### 3.2. Test Setup

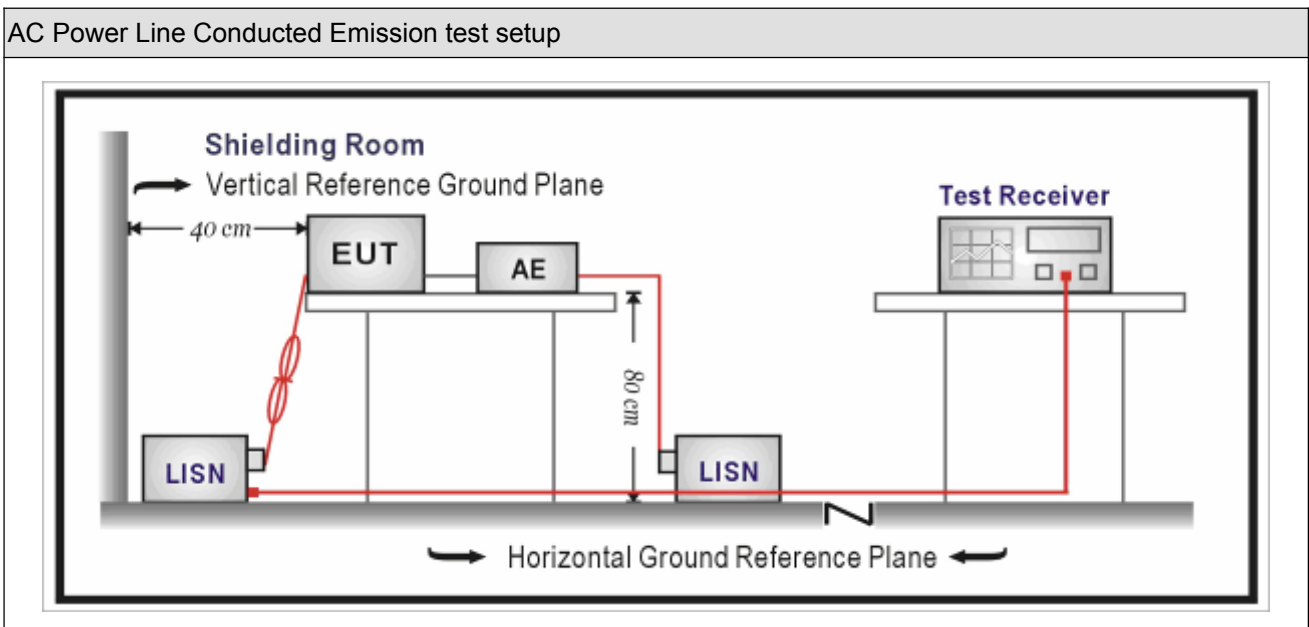

### 3.3. Limit

Frequency of Emission (MHz)	Conducted Limit	
	Quasi-peak (dB $\mu$ V)	Average (dB $\mu$ V)
0.15-0.5	66 to 56	56 to 46
0.5-5	56	46
5-30	60	50

Note 1: The lower limit shall apply at the transition frequencies.  
 Note 2: The limit decreases linearly with the logarithm of the frequency in the range 0.15 MHz to 0.5 MHz.

### 3.4. Test Procedure

Test Method			
	References Rule	Chapter	Item
<input checked="" type="checkbox"/>	ANSI C63.10-2013	6.2	Standard test method for ac power-line conducted emissions from unlicensed wireless devices
<input checked="" type="checkbox"/>	ANSI C63.4-2014	7	AC power-line conducted emission measurements

### 3.5. Test Result

Engineer: Lucas	
Site: TR1	Time: 2018/05/14 - 13:55
Limit: FCC_Part15.207_RE(3m)	Margin: 0
Probe: ENV216_101190(0.009-30MHz)	Polarity: Line
EUT: Hue Outdoor Lightstrip 5m	Power: AC 120V/60Hz
Note: Mode 1: Transmit at 2405MHz by Zigbee	

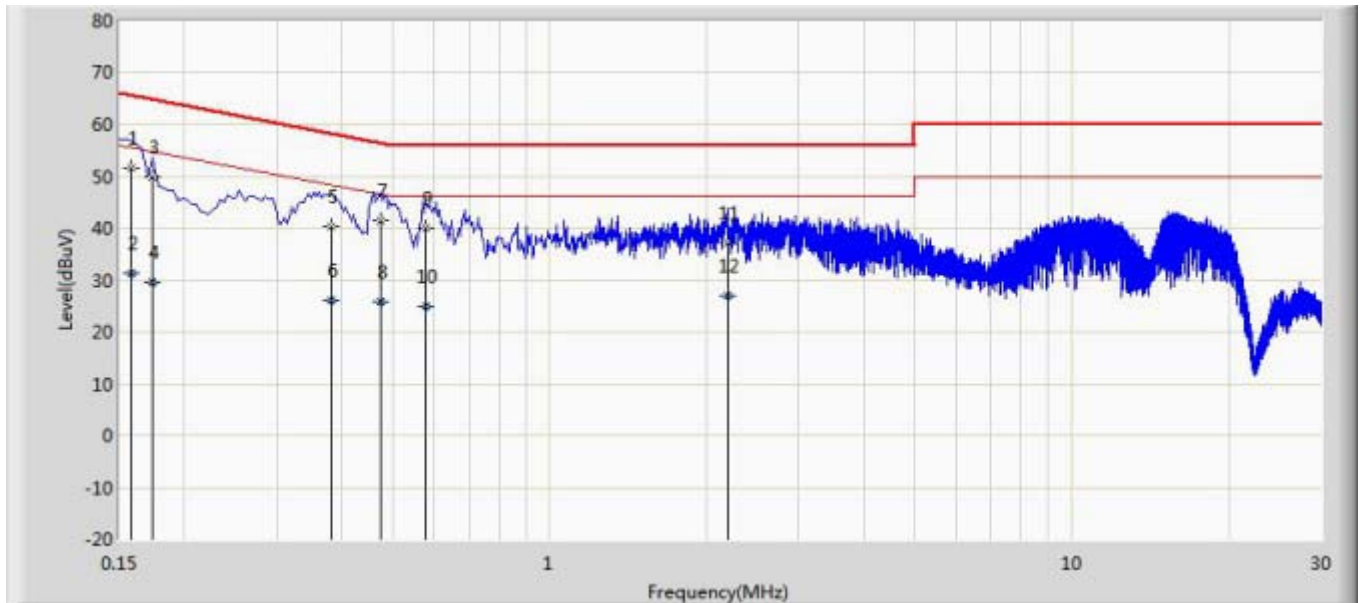

No	Mark	Frequency (MHz)	Measure Level (dBuV)	Reading Level (dBuV)	Over Limit (dB)	Limit (dBuV)	Probe (dB)	Cable (dB)	Amp (dB)	Type
1	*	0.158	51.724	42.090	-13.844	65.568	9.608	0.026	0.000	QP
2		0.158	31.288	21.654	-24.281	55.568	9.608	0.026	0.000	AV
3		0.174	49.899	40.267	-14.868	64.767	9.605	0.027	0.000	QP
4		0.174	29.672	20.040	-25.095	54.767	9.605	0.027	0.000	AV
5		0.382	40.411	30.774	-17.824	58.236	9.600	0.038	0.000	QP
6		0.382	25.992	16.355	-22.244	48.236	9.600	0.038	0.000	AV
7		0.474	41.360	31.719	-15.084	56.444	9.600	0.041	0.000	QP
8		0.474	25.825	16.184	-20.618	46.444	9.600	0.041	0.000	AV
9		0.578	40.008	30.363	-15.992	56.000	9.600	0.045	0.000	QP
10		0.578	24.801	15.156	-21.199	46.000	9.600	0.045	0.000	AV
11		2.186	37.019	27.314	-18.981	56.000	9.613	0.092	0.000	QP
12		2.186	26.862	17.157	-19.138	46.000	9.613	0.092	0.000	AV



Engineer: Lucas	
Site: TR1	Time: 2018/05/14 - 14:03
Limit: FCC_Part15.207_RE(3m)	Margin: 0
Probe: ENV216_101190(0.009-30MHz)	Polarity: Neutral
EUT: Hue Outdoor Lightstrip 5m	Power: AC 120V/60Hz
Note: Mode 1: Transmit at 2405MHz by Zigbee	

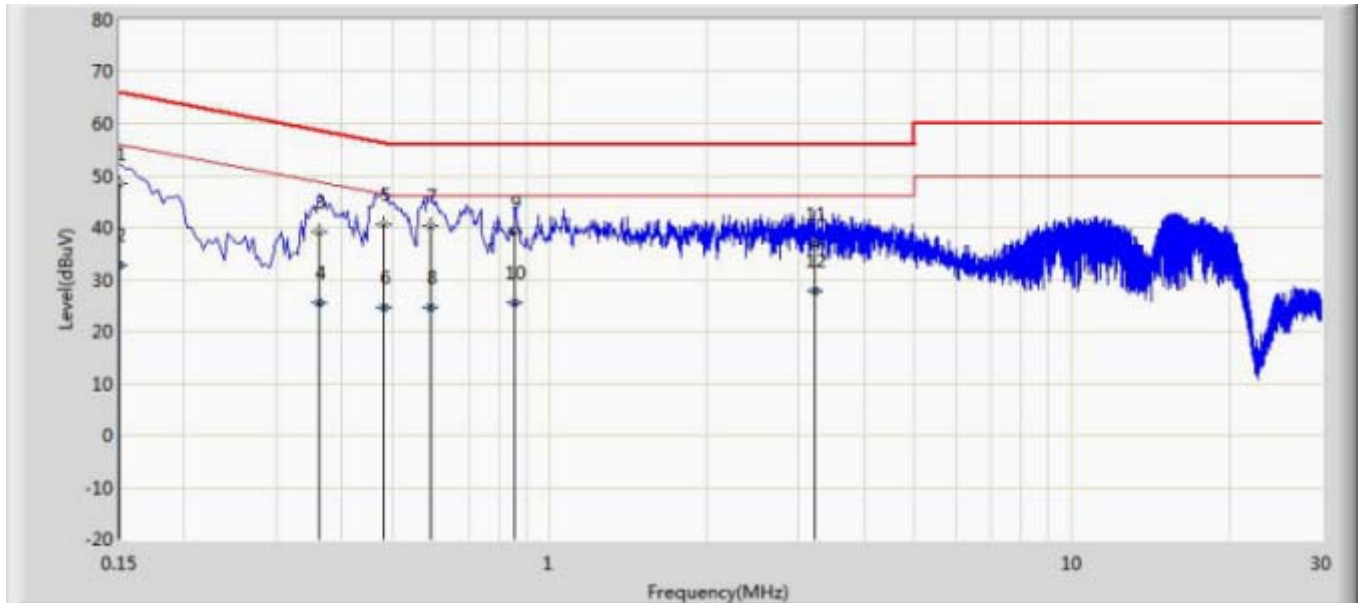

No	Mark	Frequency (MHz)	Measure Level (dBuV)	Reading Level (dBuV)	Over Limit (dB)	Limit (dBuV)	Probe (dB)	Cable (dB)	Amp (dB)	Type
1		0.150	48.476	38.857	-17.524	66.000	9.594	0.025	0.000	QP
2		0.150	32.621	23.002	-23.379	56.000	9.594	0.025	0.000	AV
3		0.362	39.239	29.609	-19.443	58.682	9.594	0.036	0.000	QP
4		0.362	25.381	15.750	-23.302	48.682	9.594	0.036	0.000	AV
5	*	0.482	40.705	31.073	-15.600	56.305	9.590	0.041	0.000	QP
6		0.482	24.569	14.938	-21.735	46.305	9.590	0.041	0.000	AV
7		0.590	40.261	30.625	-15.739	56.000	9.590	0.046	0.000	QP
8		0.590	24.554	14.918	-21.446	46.000	9.590	0.046	0.000	AV
9		0.858	39.235	29.591	-16.765	56.000	9.590	0.054	0.000	QP
10		0.858	25.493	15.849	-20.507	46.000	9.590	0.054	0.000	AV
11		3.218	36.753	27.014	-19.247	56.000	9.626	0.113	0.000	QP
12		3.218	27.797	18.059	-18.203	46.000	9.626	0.113	0.000	AV

Note:

1. All Readings below 1GHz are Quasi-Peak, above are performed with peak and/or average measurements as necessary.
2. " \* ", means this data is the worst emission level.
3. Measurement Level = Reading Level + Factor(Probe+Cable-Amp).

#### 4. Emissions in restricted frequency bands

##### 4.1. Test Equipment

Radiated Emission(Below 1GHz) / AC-2				
Instrument	Manufacturer	Type No.	Serial No.	Cal. Due Date
EMI Test Receiver	R&S	ESCI	100573	2019.03.28
Loop Antenna	R&S	HFH2-Z2	833799/003	2018.11.15
Bilog Antenna	Teseq GmbH	CBL6112D	27611	2018.10.15
Coaxial Cable	Huber+Suhner	SUCOFLEX 106	AC2-C	2019.03.01
Temperature/Humidity Meter	Zhichen	ZC1-2	AC2-TH	2019.01.02
Note: All equipment are calibrated with traceable calibrations. Each calibration is traceable to the national or international standards.				

Radiated Emission(Above 1GHz) / AC-5				
Instrument	Manufacturer	Type No.	Serial No.	Cal. Due Date
Spectrum Analyzer	Agilent	E4446A	MY45300103	2019.01.03
Preamplifier	Miteq	NSP1800-25	1364185	2019.05.05
Preamplifier	QuieTek	AP-040G	CHM-0906001	2019.05.05
DRG Horn	ETS-Lindgren	3117	00123988	2019.01.21
Broad-Band Horn Antenna	Schwarzbeck	BBHA9170	294	2018.11.24
Coaxial Cable	Huber+Suhner	SUCOFLEX 106	AC5-C1	2019.03.01
Coaxial Cable	Huber+Suhner	SUCOFLEX 106	AC5-C2	2019.03.01
Coaxial Cable	Huber+Suhner	SUCOFLEX 102	AC5-C3	2019.03.01
EMI Receiver	Agilent	N9038A	MY51210196	2019.06.09
Temperature/Humidity Meter	Zhichen	ZC1-2	AC5-TH	2019.01.03
Note: All equipment are calibrated with traceable calibrations. Each calibration is traceable to the national or international standards.				

### 4.2. Test Setup

Below 30MHz Test Setup:

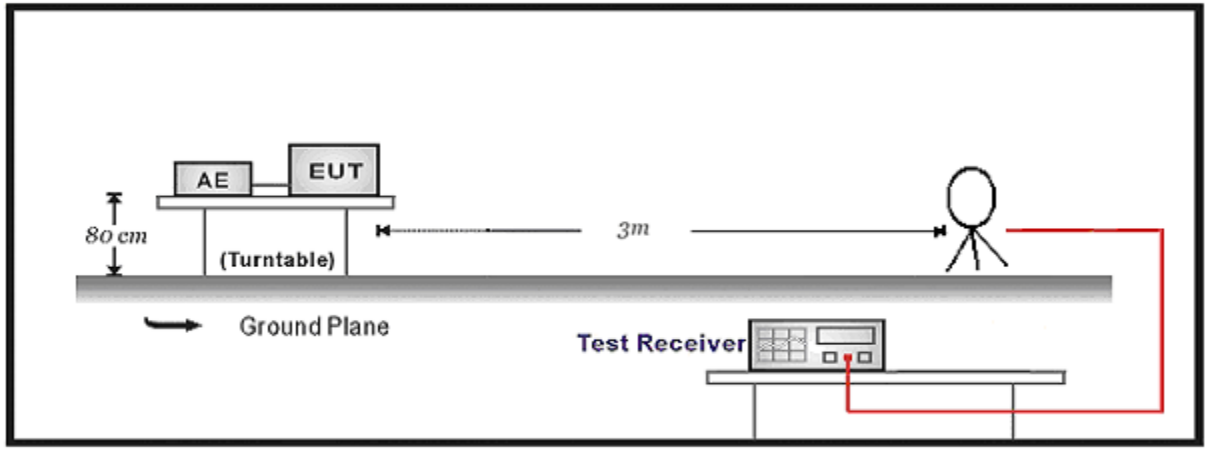

30MHz-1GHz Test Setup:

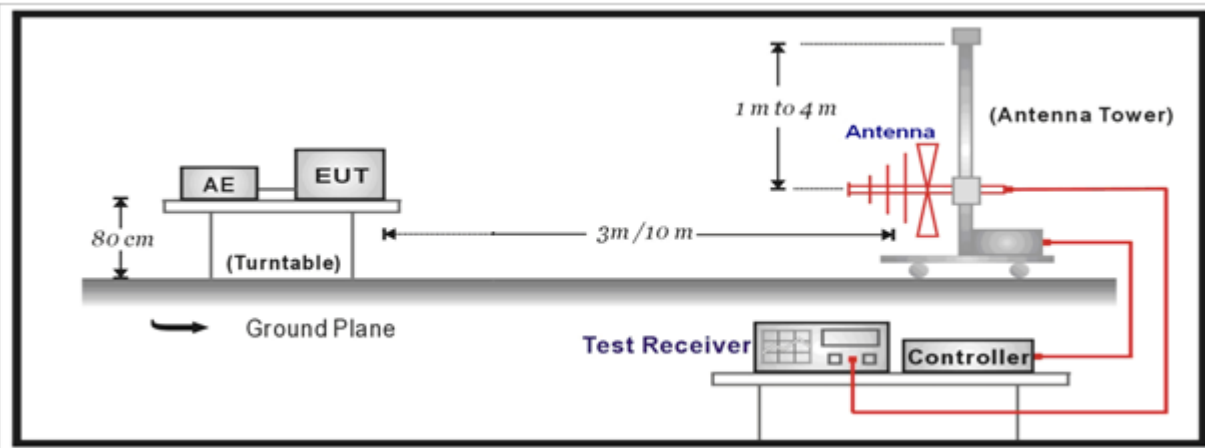

Above 1GHz Test Setup:

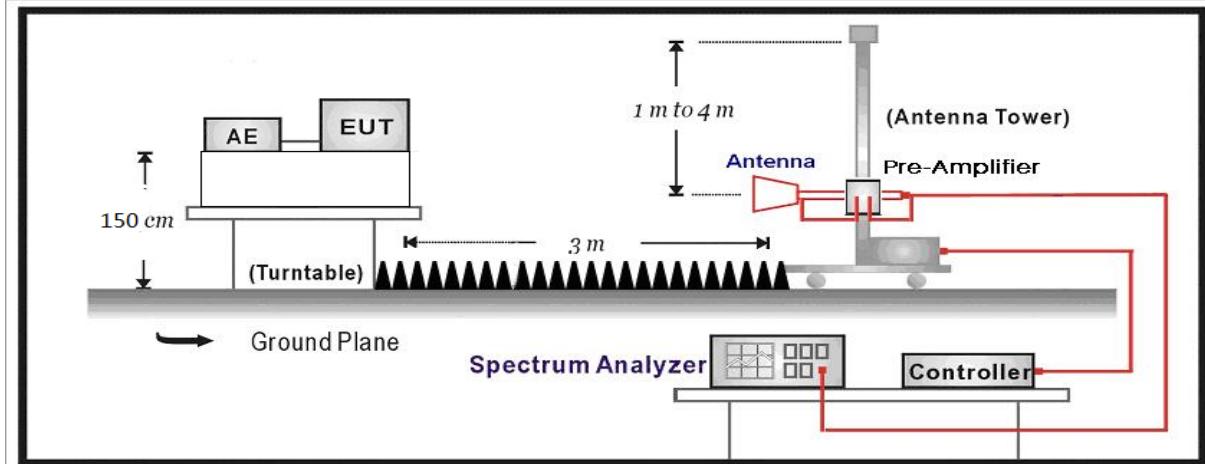

### 4.3. Limit

#### For FCC:

Restricted Bands of operation			
Frequency (MHz)	Frequency (MHz)	Frequency (MHz)	Frequency (GHz)
0.090 – 0.110	16.42 – 16.423	399.9 – 410	4.5 – 5.15
0.495 – 0.505	16.69475 – 16.69525	608 – 614	5.35 – 5.46
2.1735 – 2.1905	16.80425 – 16.80475	960 – 1240	7.25 – 7.75
4.125 – 4.128	25.5 – 25.67	1300 – 1427	8.025 – 8.5
4.17725 – 4.17775	37.5 – 38.25	1435 – 1626.5	9.0 – 9.2
4.20725 – 4.20775	73 – 74.6	1645.5 – 1646.5	9.3 – 9.5
6.215 – 6.218	74.8 – 75.2	1660 – 1710	10.6 – 12.7
6.26775 – 6.26825	108 – 121.94	1718.8 – 1722.2	13.25 – 13.4
6.31175 – 6.31225	123 – 138	2200 – 2300	14.47 – 14.5
8.291 – 8.294	149.9 – 150.05	2310 – 2390	15.35 – 16.2
8.362 – 8.366	156.52475 – 156.52525	2483.5 – 2500	17.7 – 21.4
8.37625 – 8.38675	156.7 – 156.9	2690 – 2900	22.01 – 23.12
8.81425 – 8.81475	162.0125 – 167.17	3260 – 3267	23.6 – 24.0
12.29 – 12.293	167.72 – 173.2	3332 – 3339	31.2 – 31.8
12.51975 – 12.52025	240 – 285	3345.8 – 3358	36.43 – 36.5
12.57675 – 12.57725	322 – 335.4	3600 – 4400	
13.36 – 13.41			

**For IC:**

Restricted Bands of operation			
Frequency (MHz)	Frequency (MHz)	Frequency (MHz)	Frequency (GHz)
0.090 - 0.110	13.36 - 13.41	960 - 1427	9.0 - 9.2
0.495 - 0.505	16.42 - 16.423	1435 - 1626.5	9.3 - 9.5
2.1735 - 2.1905	16.69475 - 16.69525	1645.5 - 1646.5	10.6 - 12.7
3.020 - 3.026	16.80425 - 16.80475	1660 - 1710	13.25 - 13.4
4.125 - 4.128	25.5 - 25.67	1718.8 - 1722.2	14.47 - 14.5
4.17725 - 4.17775	37.5 - 38.25	2200 - 2300	15.35 - 16.2
4.20725 - 4.20775	73 - 74.6	2310 - 2390	17.7 - 21.4
5.677 - 5.683	74.8 - 75.2	2483.5 - 2500	22.01 - 23.12
6.215 - 6.218	108 - 138	2655 - 2900	23.6 - 24.0
6.26775 - 6.26825	149.9 - 150.05	3260 - 3267	31.2 - 31.8
6.31175 - 6.31225	156.52475 - 156.52525	3332 - 3339	36.43 - 36.5
8.291 - 8.294	156.7 - 156.9	3345.8 - 3358	Above 38.6
8.362 - 8.366	162.0125 - 167.17	3500 - 4400	
8.37625 - 8.38675	167.72 - 173.2	4500 - 5150	
8.41425 - 8.41475	240 - 285	5350 - 5460	
12.29 - 12.293	322 - 335.4	7250 - 7750	
12.51975 - 12.52025	399.9 - 410	8025 - 8500	
12.57675 - 12.57725	608 - 614	--	

Restricted Band Emissions Limit			
Frequency (MHz)	Field strength ( $\mu$ V/m)	Field strength (dB $\mu$ V/m)	Measurement distance (m)
0.009 - 0.49	2400/F(kHz)	48.5 – 13.8	300 <sub>(Note 1)</sub>
0.49 - 1.705	24000/F(kHz)	33.8 - 23	30 <sub>(Note 1)</sub>
1.705 - 30	30	29.5	30 <sub>(Note 1)</sub>
30 - 88	100	40	3 <sub>(Note 2)</sub>
88 - 216	150	43.5	3 <sub>(Note 2)</sub>
216 - 960	200	46	3 <sub>(Note 2)</sub>
Above 960	500	54	3 <sub>(Note 2)</sub>

Note 1: At frequencies below 30 MHz, measurements may be performed at a distance closer than that specified in the regulations; however, an attempt should be made to avoid making measurements in the near field. Pending the development of an appropriate measurement procedure for measurements performed below 30 MHz, when performing measurements at a closer distance than specified, the results shall be extrapolated to the specified distance by either making measurements at a minimum of two distances on at least one radial to determine the proper extrapolation factor or by using the square of an inverse linear distance extrapolation factor (40 dB/decade).





Note 2: At frequencies at or above 30 MHz, measurements may be performed at a distance other than what is specified provided: measurements are not made in the near field except where it can be shown that near field measurements are appropriate due to the characteristics of the device; and it can be demonstrated that the signal levels needed to be measured at the distance employed can be detected by the measurement equipment. Measurements shall not be performed at a distance greater than 30 meters unless it can be further demonstrated that measurements at a distance of 30 meters or less are impractical. When performing measurements at a distance other than that specified, the results shall be extrapolated to the specified distance using an extrapolation factor of 20 dB/decade (inverse linear-distance for field strength measurements; inverse-linear-distance-squared for power density measurements).

#### 4.4. Test Procedure

Test Method			
	References Rule	Chapter	Description
<input type="checkbox"/>	ANSI C63.10	11.11	Emissions in non-restricted frequency bands
	<input type="checkbox"/> ANSI C63.10	11.11.2	Reference level measurement
	<input type="checkbox"/> ANSI C63.10	11.11.3	Emission level measurement
<input checked="" type="checkbox"/>	ANSI C63.10	11.12	Emissions in restricted frequency bands
	<input checked="" type="checkbox"/> ANSI C63.10	11.12.1	Radiated emission measurements
	<input checked="" type="checkbox"/> ANSI C63.10	11.12.2.7	Radiated spurious emission test
	<input checked="" type="checkbox"/> ANSI C63.10	6.4	Radiated emissions from unlicensed wireless devices below 30 MHz
	<input checked="" type="checkbox"/> ANSI C63.10	6.5	Radiated emissions from unlicensed wireless devices in the frequency range of 30 MHz to 1000 MHz
	<input checked="" type="checkbox"/> ANSI C63.10	6.6	Radiated emissions from unlicensed wireless devices above 1 GHz
	<input type="checkbox"/> ANSI C63.10	11.12.2.3	Quasi-peak measurement procedure
	<input checked="" type="checkbox"/> ANSI C63.10	11.12.2.4	Peak power measurement procedure
	<input checked="" type="checkbox"/> ANSI C63.10	11.12.2.5	Average power measurement procedures
	<input type="checkbox"/> ANSI C63.10	11.12.2.5.1	Trace averaging with continuous EUT transmission at full power
	<input type="checkbox"/> ANSI C63.10	11.12.2.5.2	Trace averaging across ON and OFF times of the EUT transmissions followed by duty cycle correction
	<input checked="" type="checkbox"/> ANSI C63.10	11.12.2.5.3	Reduced VBW averaging across ON and OFF times of the EUT transmissions with max hold

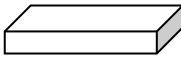
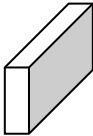
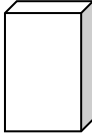

**4.5. EUT test Axis definition**

Item	Emissions in restricted frequency bands			
Device Category	<input type="checkbox"/>	Fixed point-to-point		
	<input type="checkbox"/>	Emit multiple directional beams, simultaneously or sequentially		
	<input checked="" type="checkbox"/>	Other cases		
Test mode	Mode 1			
Test method	<input checked="" type="checkbox"/>	Radiated		
		X Axis	Y Axis	Z Axis
				
		Worst Axis <input checked="" type="checkbox"/>	Worst Axis <input type="checkbox"/>	Worst Axis <input type="checkbox"/>
	<input type="checkbox"/>	Conducted		
	<input type="checkbox"/>	Chain 0		
				
	<input type="checkbox"/>	Chain 0	Chain 1	
				
	<input type="checkbox"/>	Chain 0	Chain 1	Chain 2
				

### 4.6. Test Result

Site: AC5	Time: 2018/05/24 - 11:05
Limit: FCC_Part15.209_RE(3m)	Margin: 0
Probe: Horn_3117_00167055(1-18GHz)	Polarity: Horizontal
EUT: Hue Outdoor Lightstrip 5m	Power: AC 120V/60Hz
Note: Mode 1:Transmit at 2405MHz by zigbee	

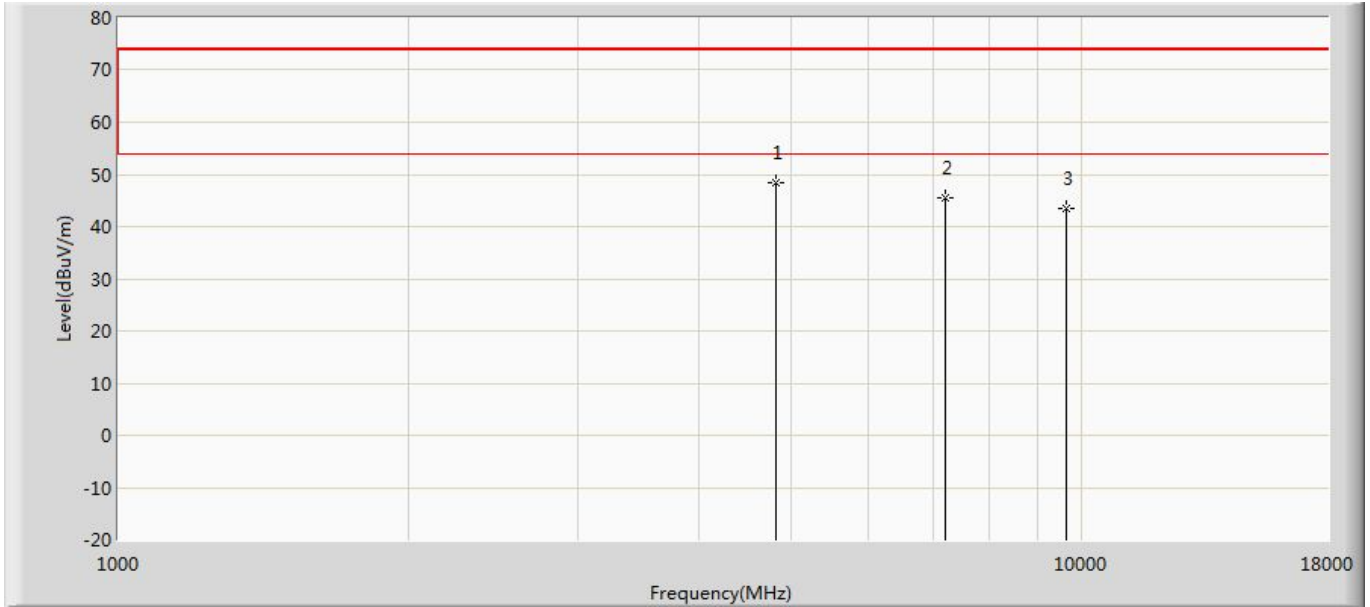

No	Mark	Frequency (MHz)	Measure Level (dBuV/m)	Reading Level (dBuV)	Over Limit (dB)	Limit (dBuV/m)	Factor (dB)	Type
1	*	4808.000	48.327	48.843	-25.673	74.000	-0.516	PK
2		7215.000	45.585	41.828	-28.415	74.000	3.757	PK
3		9620.000	43.561	37.172	-30.439	74.000	6.389	PK

Site: AC5	Time: 2018/05/24 - 11:05
Limit: FCC_Part15.209_RE(3m)	Margin: 0
Probe: Horn_3117_00167055(1-18GHz)	Polarity: Vertical
EUT: Hue Outdoor Lightstrip 5m	Power: AC 120V/60Hz
Note: Mode 1:Transmit at 2405MHz by zigbee	

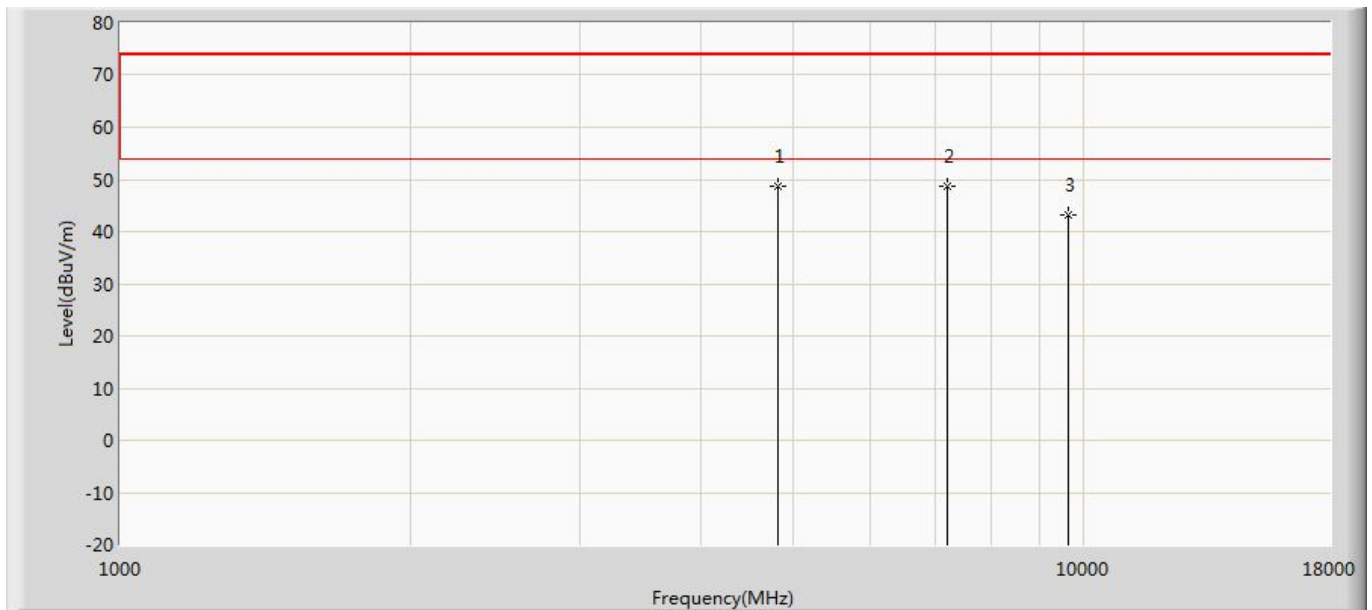

No	Mark	Frequency (MHz)	Measure Level (dBuV/m)	Reading Level (dBuV)	Over Limit (dB)	Limit (dBuV/m)	Factor (dB)	Type
1		4808.000	48.814	49.330	-25.186	74.000	-0.516	PK
2	*	7213.500	48.832	45.031	-25.168	74.000	3.800	PK
3		9620.000	43.209	36.820	-30.791	74.000	6.389	PK

Site: AC5	Time: 2018/05/24 - 11:05
Limit: FCC_Part15.209_RE(3m)	Margin: 0
Probe: Horn_3117_00167055(1-18GHz)	Polarity: Horizontal
EUT: Hue Outdoor Lightstrip 5m	Power: AC 120V/60Hz
Note: Mode 1:Transmit at 2450MHz by zigbee	

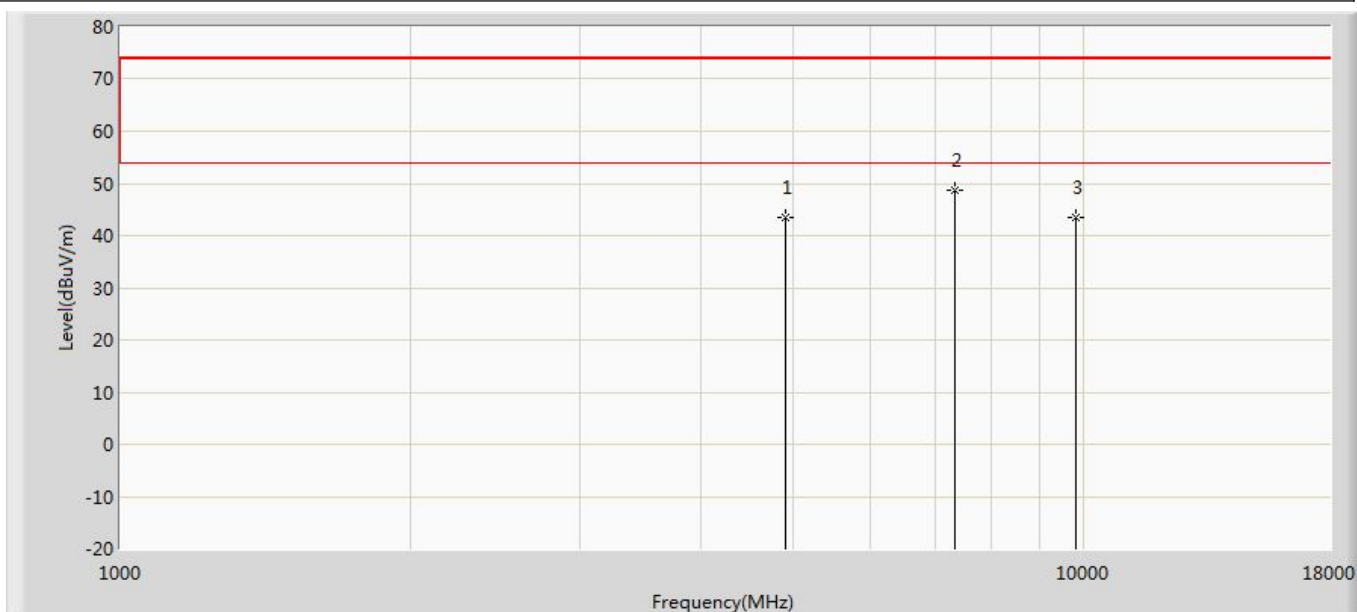

No	Mark	Frequency (MHz)	Measure Level (dBuV/m)	Reading Level (dBuV)	Over Limit (dB)	Limit (dBuV/m)	Factor (dB)	Type
1		4900.000	43.566	43.978	-30.434	74.000	-0.413	PK
2	*	7349.500	48.650	45.178	-25.350	74.000	3.472	PK
3		9800.000	43.381	37.668	-30.619	74.000	5.713	PK

Site: AC5	Time: 2018/05/24 - 11:05
Limit: FCC_Part15.209_RE(3m)	Margin: 0
Probe: Horn_3117_00167055(1-18GHz)	Polarity: Vertical
EUT: Hue Outdoor Lightstrip 5m	Power: AC 120V/60Hz
Note: Mode 1:Transmit at 2450MHz by zigbee	

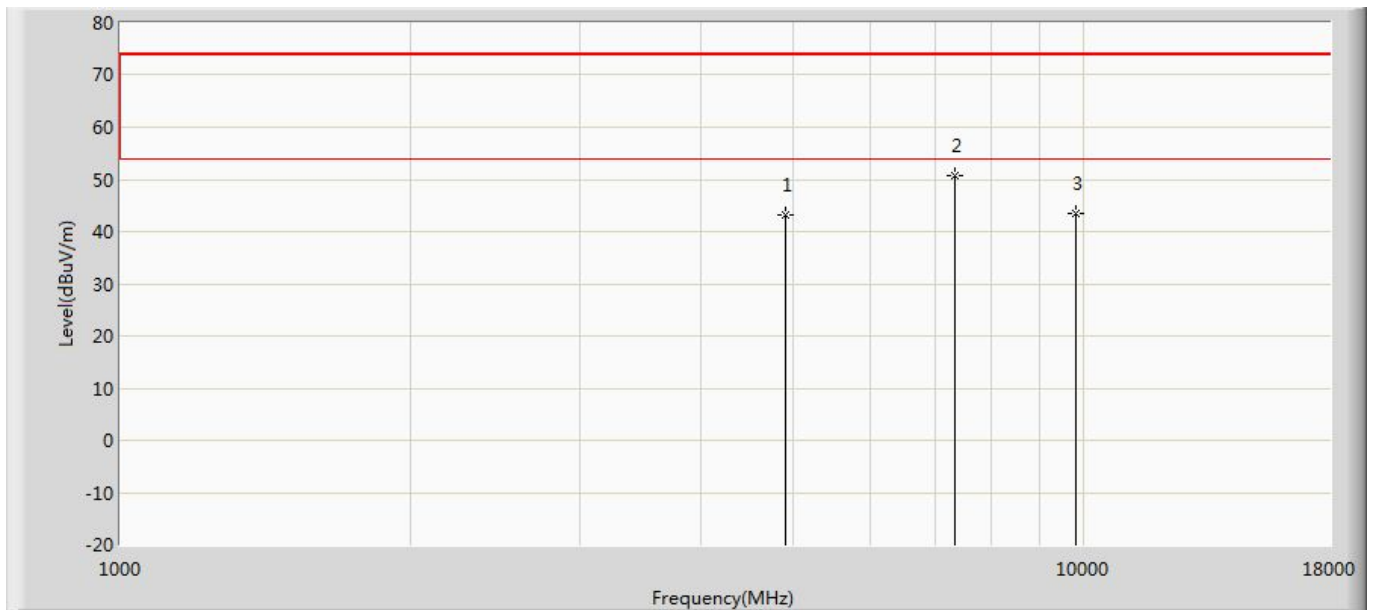

No	Mark	Frequency (MHz)	Measure Level (dBuV/m)	Reading Level (dBuV)	Over Limit (dB)	Limit (dBuV/m)	Factor (dB)	Type
1		4900.000	43.097	43.509	-30.903	74.000	-0.413	PK
2	*	7349.500	50.705	47.233	-23.295	74.000	3.472	PK
3		9800.000	43.348	37.635	-30.652	74.000	5.713	PK

Site: AC5	Time: 2018/05/24 - 11:06
Limit: FCC_Part15.209_RE(3m)	Margin: 0
Probe: Horn_3117_00167055(1-18GHz)	Polarity: Horizontal
EUT: Hue Outdoor Lightstrip 5m	Power: AC 120V/60Hz
Note: Mode 1:Transmit at 2480MHz by zigbee	

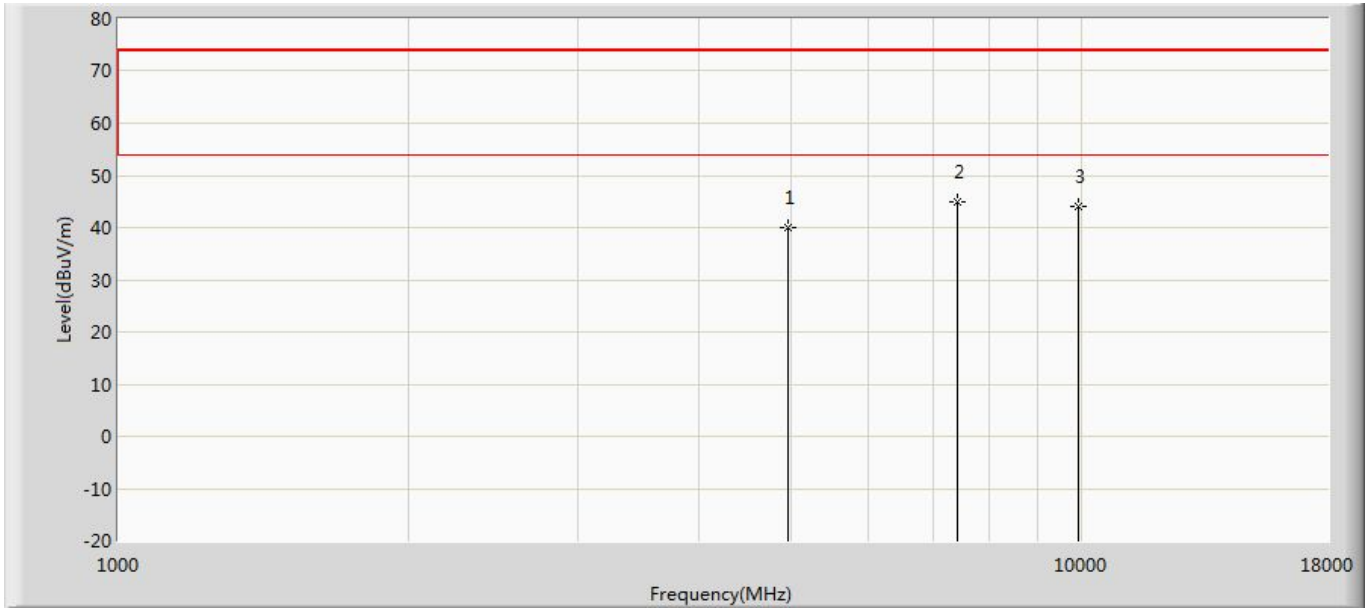

No	Mark	Frequency (MHz)	Measure Level (dBuV/m)	Reading Level (dBuV)	Over Limit (dB)	Limit (dBuV/m)	Factor (dB)	Type
1		4960.000	40.140	41.017	-33.860	74.000	-0.877	PK
2	*	7440.000	45.000	41.361	-29.000	74.000	3.638	PK
3		9920.000	44.167	38.201	-29.833	74.000	5.966	PK

Site: AC5	Time: 2018/05/24 - 11:06
Limit: FCC_Part15.209_RE(3m)	Margin: 0
Probe: Horn_3117_00167055(1-18GHz)	Polarity: Vertical
EUT: Hue Outdoor Lightstrip 5m	Power: AC 120V/60Hz
Note: Mode 1:Transmit at 2480MHz by zigbee	

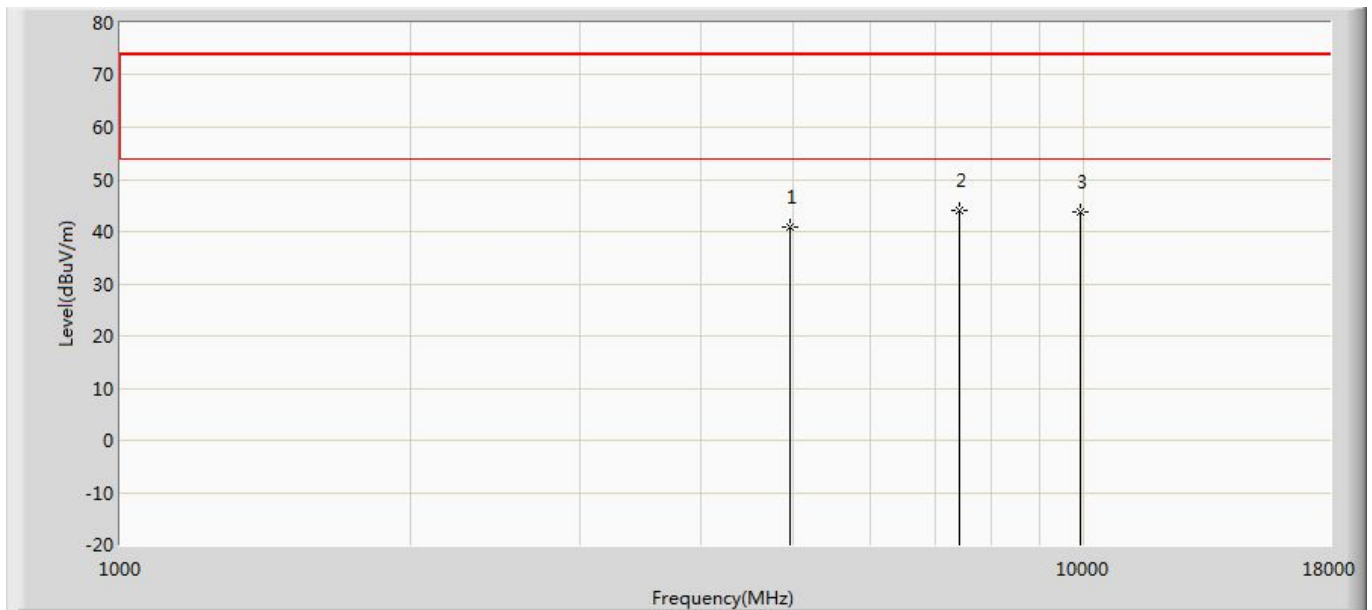

No	Mark	Frequency (MHz)	Measure Level (dBuV/m)	Reading Level (dBuV)	Over Limit (dB)	Limit (dBuV/m)	Factor (dB)	Type
1		4960.000	40.943	41.820	-33.057	74.000	-0.877	PK
2	*	7440.000	44.028	40.389	-29.972	74.000	3.638	PK
3		9920.000	43.911	37.945	-30.089	74.000	5.966	PK

**Note:**

1. Measured Level = Reading Level + Factor.
2. The test frequency range, 9kHz~30MHz, 18GHz~26GHz, both of the worst case are at least 20dB below the limits, therefore no data appear in the report.
3. This limit applies for using average detector, if the test result on peak is lower than average limit, then average measurement needn't be performed.
4. As the radiated emission was performed, so conducted emission was not tested.

**The worst case of Radiated Emission below 1GHz:**

Engineer: Allen	
Site: AC3	Time: 2018/05/24 - 10:20
Limit: FCC_Part15.109_RE(3m)_ClassB	Margin: 0
Probe: AC3_3m (30-1000MHz)	Polarity: Horizontal
EUT: Hue Outdoor Lightstrip 5ming Chain	Power: AC 120V/60Hz
Note: Mode 1:Transmit at 2450MHz by zigbee	

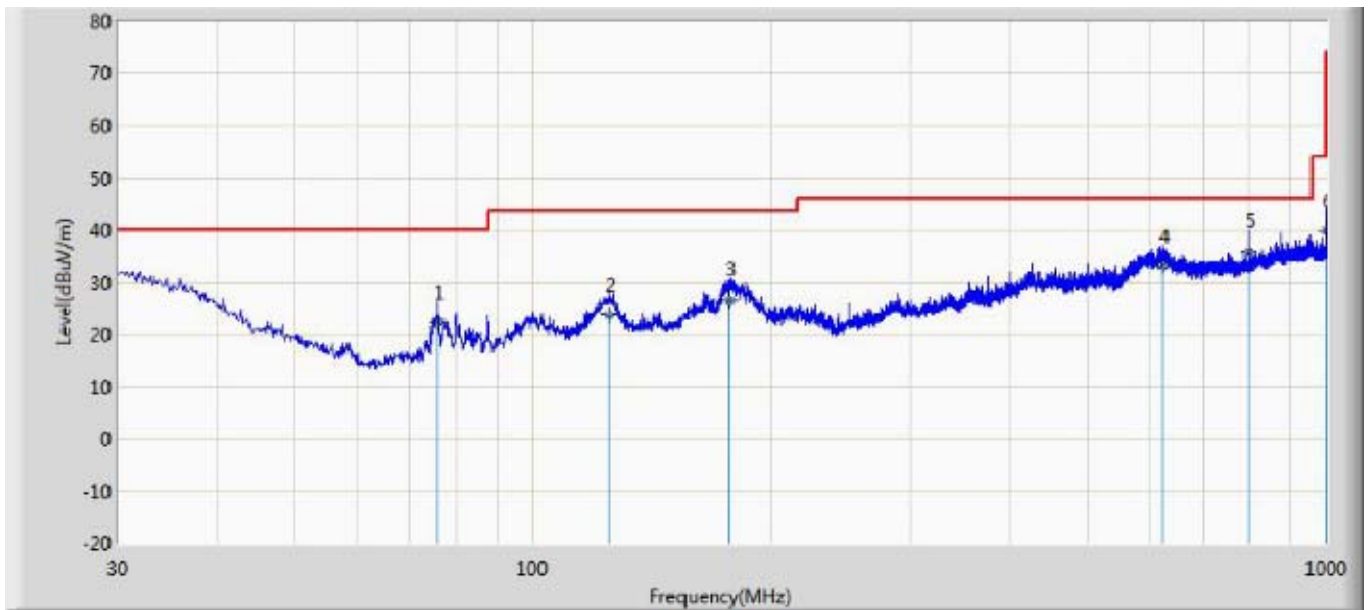

No	Mark	Frequency (MHz)	Measure Level (dBuV/m)	Reading Level (dBuV)	Over Limit (dB)	Limit (dBuV/m)	Factor (dB)	Type
1		75.954	22.241	10.500	-17.759	40.000	11.740	QP
2		124.939	23.905	7.500	-19.595	43.500	16.405	QP
3		177.197	26.555	9.300	-16.945	43.500	17.255	QP
4		621.579	33.166	3.500	-12.834	46.000	29.666	QP
5	*	800.089	35.905	6.200	-10.095	46.000	29.704	QP
6		999.845	40.003	7.600	-13.997	54.000	32.403	QP



Engineer: Allen	
Site: AC3	Time: 2018/05/24 - 10:29
Limit: FCC_Part15.109_RE(3m)_ClassB	Margin: 0
Probe: AC3_3m (30-1000MHz)	Polarity: Vertical
EUT: Hue Outdoor Lightstrip 5m	Power: AC 120V/60Hz
Note: Mode 1:Transmit at 2450MHz by zigbee	

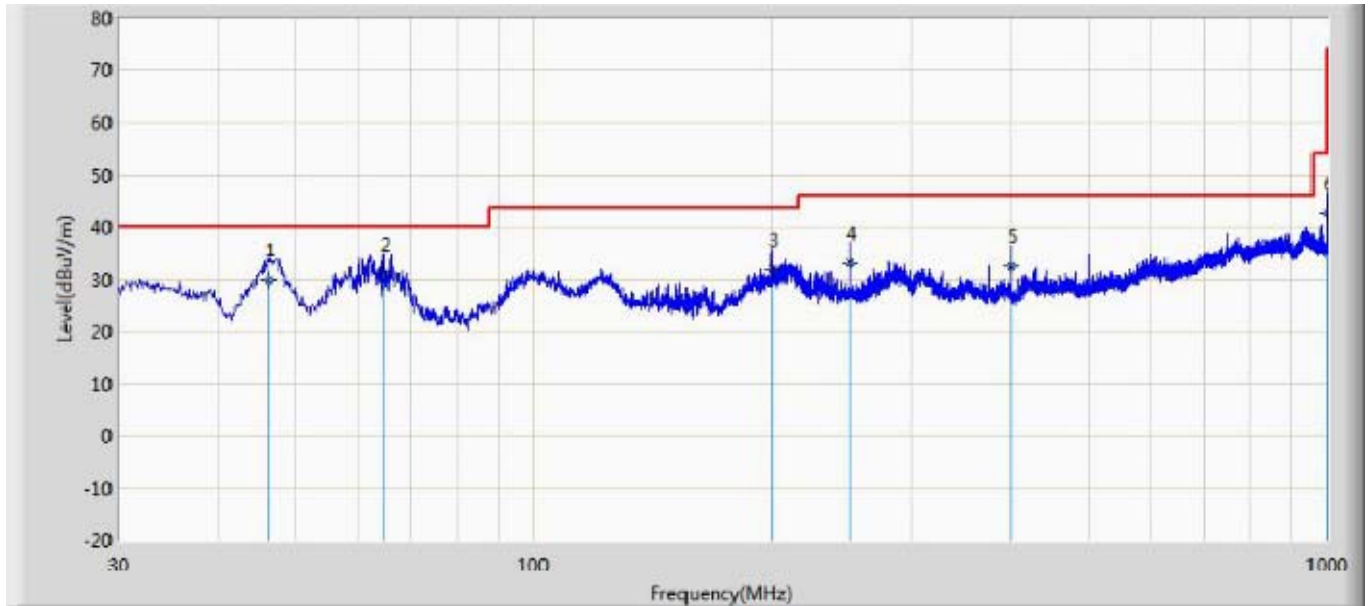

No	Mark	Frequency (MHz)	Measure Level (dBuV/m)	Reading Level (dBuV)	Over Limit (dB)	Limit (dBuV/m)	Factor (dB)	Type
1		46.248	29.971	12.000	-10.029	40.000	17.971	QP
2	*	64.799	31.061	15.200	-8.939	40.000	15.861	QP
3		199.750	31.923	9.500	-11.577	43.500	22.423	QP
4		249.947	32.936	9.500	-13.064	46.000	23.436	QP
5		399.934	32.451	8.800	-13.549	46.000	23.651	QP
6		999.472	42.595	10.100	-11.405	54.000	32.495	QP

## 5. Emissions in non-restricted frequency bands

### 5.1. Test Equipment

Emissions in non-restricted frequency bands / TR-8					
Instrument	Manufacturer	Type No.	Serial No.	Cal. Date	Cal. Due Date
Spectrum Analyzer	Agilent	N9010A	MY48030494	2018.02.04	2019.02.03
EXA Spectrum Analyzer	Keysight	N9010A	MY55370495	2018.04.09	2019.04.08
MXA Signal Analyzer	Keysight	N9020A	MY56060147	2018.04.09	2019.04.08
Temperature/Humidity Meter	zhichen	ZC1-2	TR8-TH	2018.04.10	2019.04.09

Note: All equipment are calibrated with traceable calibrations. Each calibration is traceable to the national or international standards.

### 5.2. Test Setup

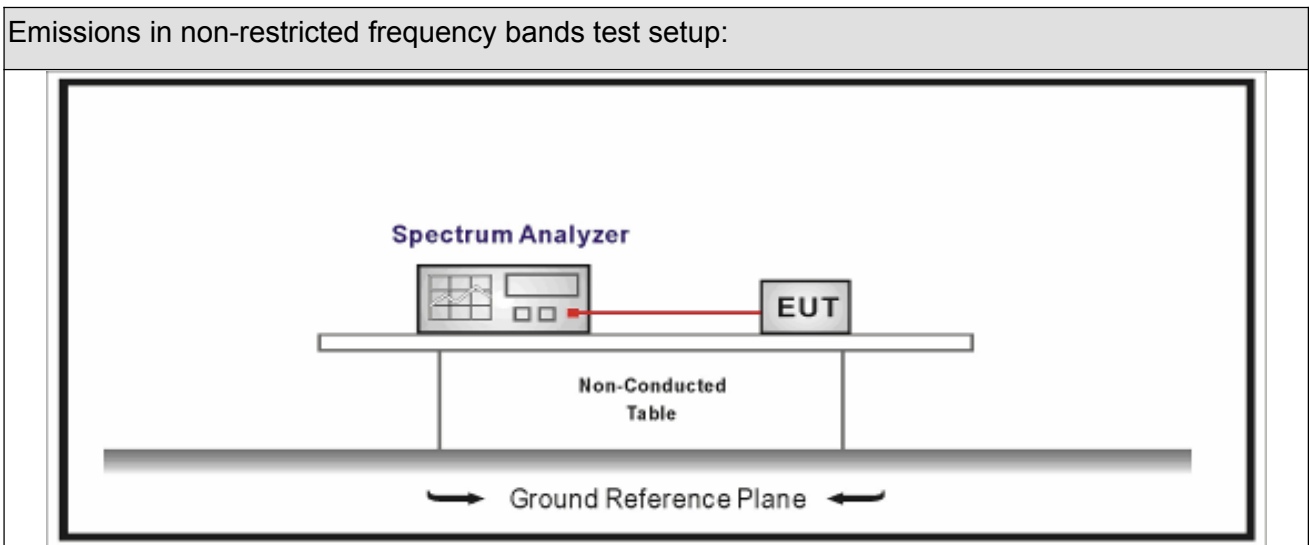





### 5.3. Limit

Un-Restricted Band Emissions Limit	
RF Output power (Detection methods)	Limit(dB)
RF Output power(Average detector)	30c(Note1)
RF Output power(PK detector)	20c(Note2)
<p>Note 1: If maximum conducted (average) output power was used to demonstrate compliance as described in 9.2, then the peak power in any 100 kHz bandwidth outside of the authorized frequency band shall be attenuated by at least 30 dB relative to the maximum in-band peak PSD level in 100 kHz (i.e., 30 dBc).</p> <p>Note 2: If the maximum peak conducted output power procedure was used, then the peak output power measured in any 100 kHz bandwidth outside of the authorized frequency band shall be attenuated by at least 20 dB relative to the maximum in-band peak PSD level in 100 kHz (i.e., 20 dBc).</p>	

### 5.4. Test Procedure

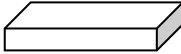
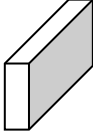
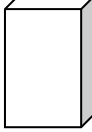
Test Method			
	References Rule	Chapter	Description
<input checked="" type="checkbox"/>	ANSI C63.10	11.11	Emissions in non-restricted frequency bands
	<input checked="" type="checkbox"/> ANSI C63.10	11.11.2	Reference level measurement
	<input checked="" type="checkbox"/> ANSI C63.10	11.11.3	Emission level measurement
<input type="checkbox"/>	ANSI C63.10	11.12	Emissions in restricted frequency bands
	<input type="checkbox"/> ANSI C63.10	11.12.1	Radiated emission measurements
	<input type="checkbox"/> ANSI C63.10	11.12.2.7	Radiated spurious emission test
<input type="checkbox"/>	ANSI C63.10	6.4	Radiated emissions from unlicensed wireless devices below 30 MHz
<input type="checkbox"/>	ANSI C63.10	6.5	Radiated emissions from unlicensed wireless devices in the frequency range of 30 MHz to 1000 MHz
<input type="checkbox"/>	ANSI C63.10	6.6	Radiated emissions from unlicensed wireless devices above 1 GHz
	<input checked="" type="checkbox"/> ANSI C63.10	11.12.2	Antenna-port conducted measurements
	<input type="checkbox"/> ANSI C63.10	11.12.2.3	Quasi-peak measurement procedure
	<input checked="" type="checkbox"/> ANSI C63.10	11.12.2.4	Peak power measurement procedure
	<input type="checkbox"/> ANSI C63.10	11.12.2.5	Average power measurement procedures
	<input type="checkbox"/> ANSI C63.10	11.12.2.5.1	Trace averaging with continuous EUT transmission at full power
	<input type="checkbox"/> ANSI C63.10	11.12.2.5.2	Trace averaging across ON and OFF times of the EUT transmissions followed by duty cycle correction
	<input type="checkbox"/> ANSI C63.10	11.12.2.5.3	Reduced VBW averaging across ON and OFF times of the EUT transmissions with max hold

**5.5. EUT test Axis definition**

Item	Emissions in non-restricted frequency bands			
Device Category	<input type="checkbox"/>	Fixed point-to-point		
	<input type="checkbox"/>	Emit multiple directional beams, simultaneously or sequentially		
	<input checked="" type="checkbox"/>	Other cases		
Test mode	Mode 1			
Test method	<input type="checkbox"/>	Radiated		
		X Axis	Y Axis	Z Axis
				
		Worst Axis <input type="checkbox"/>	Worst Axis <input type="checkbox"/>	Worst Axis <input type="checkbox"/>
	<input checked="" type="checkbox"/>	Conducted		
	<input checked="" type="checkbox"/>	Chain 0		
				
	<input type="checkbox"/>	Chain 0	Chain 1	
				
	<input type="checkbox"/>	Chain 0	Chain 1	Chain 2
				

### 5.6. Test Result

Product Name	: Hue Outdoor Lightstrip 5m	Power	: AC 120V/60Hz
Test Mode	: Mode 1	Test Site	: TR-8
Test Date	: 2018.05.30	Test engineer	: Allen

Mode	Channel	Test Frequency (MHz)	In-Band PSD[a] (dBm/100kHz)	Frequency (MHz)	Out-Band PSD[b] (dBm/100kHz)	[a]-[b] (dB)	Limit (dB)	Result
1	11	2405	1.334	2405.09	-43.962	45.296	>20	Pass
1	26	2480	-8.110	2500.00	-58.101	49.991	>20	Pass

Note: The worst case of Emissions in non-restricted frequency bands as below:

#### Mode 1 CH11 (2405MHz)

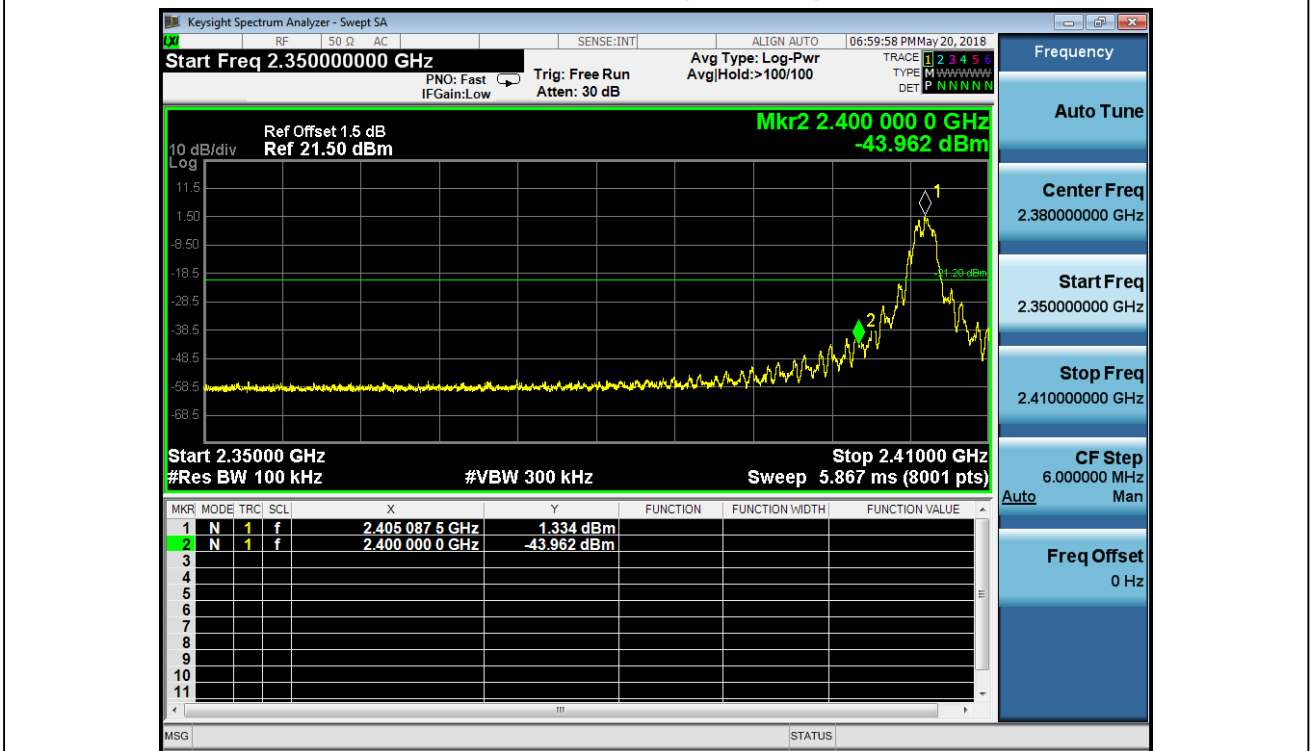

## 6. Radiated Emission Band Edge

### 6.1. Test Equipment

Radiated Emission(Above 1GHz) / AC-5					
Instrument	Manufacturer	Type No.	Serial No.	Cal. Date	Cal. Due Date
EMI Receiver	Agilent	N9038A	MY51210196	2017.07.16	2018.07.15
Pre-Amplifier	Miteq	NSP1800-25	1364185	2018.05.03	2019.05.02
DRG Horn Antenna	ETS-Lindgren	3117	00167055	2017.07.12	2018.07.11
Broad-Band Horn Antenna	Schwarzbeck	BBHA9170	294	2017.09.18	2018.09.17
Coaxial Cable	Huber+Suhner	SUCOFLEX 106	AC5-C1	2018.02.28	2019.02.27
Coaxial Cable	Huber+Suhner	SUCOFLEX 106	AC5-C2	2018.02.28	2019.02.27
Temperature/Humidity Meter	Zhichen	ZC1-2	AC5-TH	2017.01.05	2019.01.04

### 6.2. Test Setup

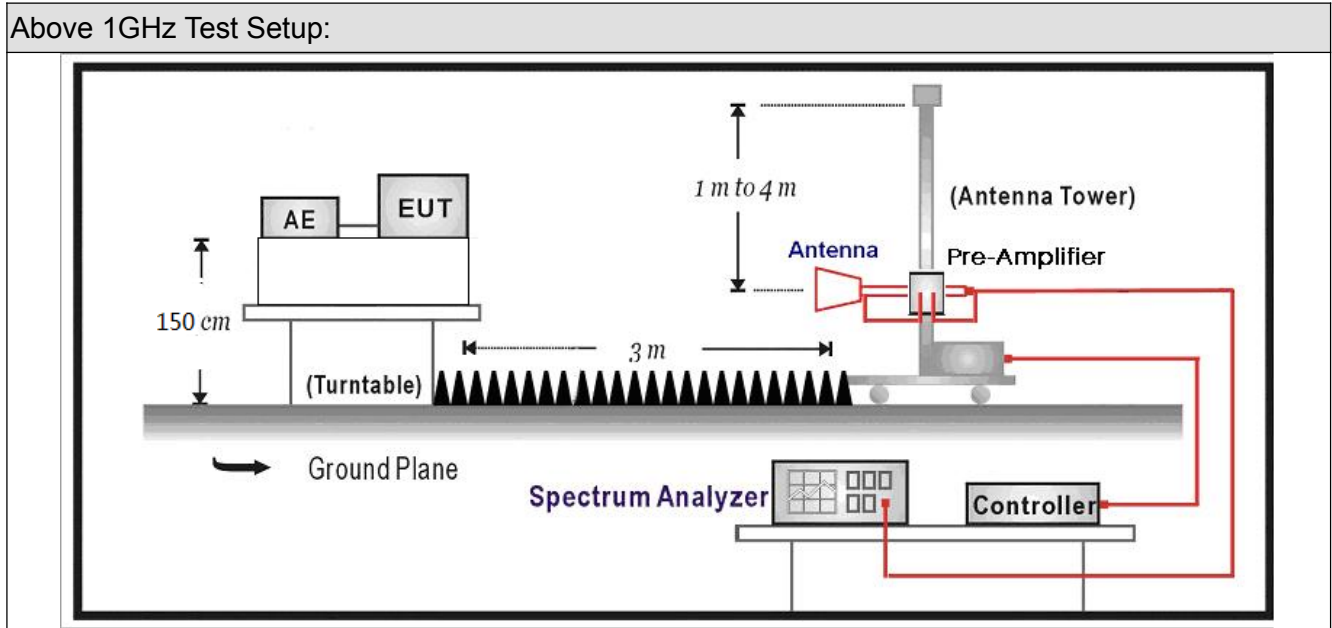

### 6.3. Limit

Band edge Limit				
Frequency bands (MHz)	Detector	Limit (dB $\mu$ V/m)	RBW (MHz)	Distance (m)
2310-2390	PK	74	1	3
2483.5-2500	AV	54	1	3





Note: The field strength of emissions appearing within these frequency bands shall not exceed the limits

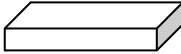
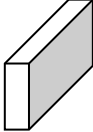
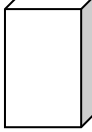

### 6.4. Test Procedure

Test Method				
	References Rule		Chapter	Description
<input checked="" type="checkbox"/>	ANSI C63.10		6.10	Band-edge testing
	<input checked="" type="checkbox"/>	ANSI C63.10	6.10.5	Restricted-band band-edge measurements
	<input type="checkbox"/>	ANSI C63.10	6.10.6	Marker-delta method
<input checked="" type="checkbox"/>	ANSI C63.10		11.12	Emissions in restricted frequency bands
	<input checked="" type="checkbox"/>	ANSI C63.10	11.12.1	Radiated emission measurements
	<input checked="" type="checkbox"/>	ANSI C63.10	11.12.2.7	Radiated spurious emission test
<input type="checkbox"/>	ANSI C63.10		6.4	Radiated emissions from unlicensed wireless devices below 30 MHz
<input type="checkbox"/>	ANSI C63.10		6.5	Radiated emissions from unlicensed wireless devices in the frequency range of 30 MHz to 1000 MHz
<input checked="" type="checkbox"/>	ANSI C63.10		6.6	Radiated emissions from unlicensed wireless devices above 1 GHz
	<input type="checkbox"/>	ANSI C63.10	11.12.2.3	Quasi-peak measurement procedure
	<input checked="" type="checkbox"/>	ANSI C63.10	11.12.2.4	Peak power measurement procedure
	<input checked="" type="checkbox"/>	ANSI C63.10	11.12.2.5	Average power measurement procedures
	<input type="checkbox"/>	ANSI C63.10	11.12.2.5.1	Trace averaging with continuous EUT transmission at full power
	<input type="checkbox"/>	ANSI C63.10	11.12.2.5.2	Trace averaging across ON and OFF times of the EUT transmissions followed by duty cycle correction
	<input checked="" type="checkbox"/>	ANSI C63.10	11.12.2.5.3	Reduced VBW averaging across ON and OFF times of the EUT transmissions with max hold

**6.5. EUT test definition**

Item	Radiated Emission Band Edge			
Device Category	<input type="checkbox"/>	Fixed point-to-point		
	<input type="checkbox"/>	Emit multiple directional beams, simultaneously or sequentially		
	<input checked="" type="checkbox"/>	Other cases		
Test mode	Mode 1			
Test method	<input checked="" type="checkbox"/>	Radiated		
		X Axis	Y Axis	Z Axis
				
		Worst Axis <input checked="" type="checkbox"/>	Worst Axis <input type="checkbox"/>	Worst Axis <input type="checkbox"/>
	<input type="checkbox"/>	Conducted		
	<input type="checkbox"/>	Chain 0		
				
	<input type="checkbox"/>	Chain 0	Chain 1	
				
	<input type="checkbox"/>	Chain 0	Chain 1	Chain 2
				

### 6.6. Duty Cycle

Test Mode	Tx On (ms)	Tx Off (ms)	Reduced VBW (kHz)	Tx On + Tx Off (ms)	Duty Cycle
Zigbee	-	-	10Hz	-	100%

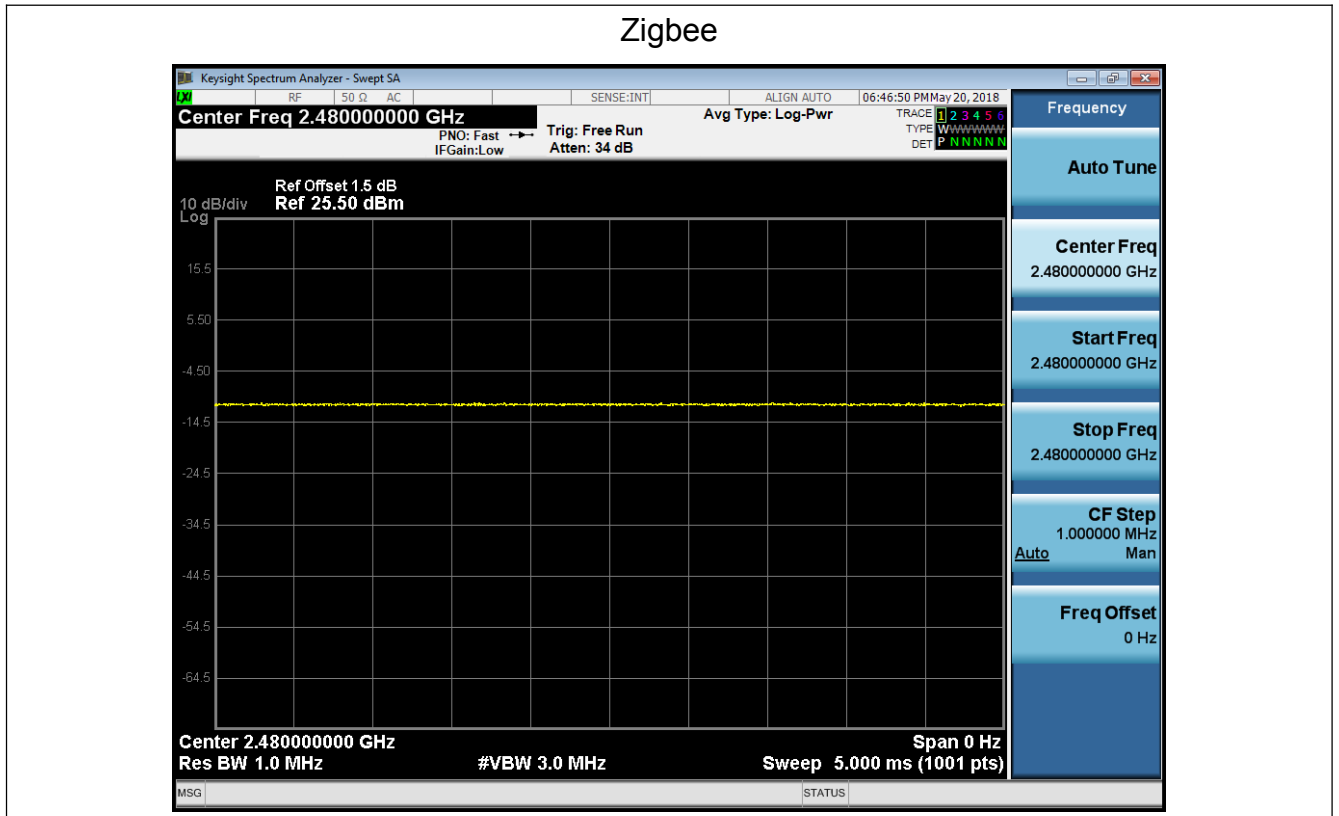

### 6.7 Test Result

Engineer: Allen	
Site: AC5	Time: 2018/05/16 - 16:39
Limit: FCC_Part15.209_RE(3m)	Margin: 0
Probe: Horn_3117_00167055(1-18GHz)	Polarity: Horizontal
EUT: Hue Outdoor Lightstrip 5m	Power: AC 120V/60Hz
Note: Mode 1:Transmit at 2405MHz by zigbee	

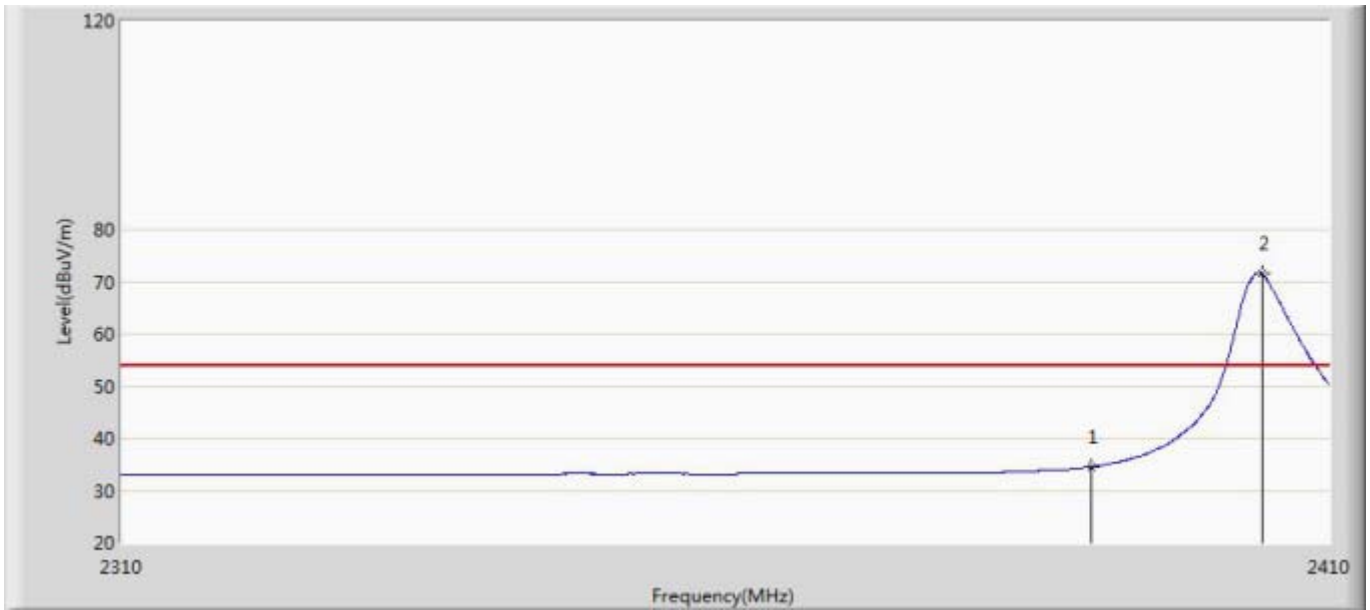

No	Mark	Frequency (MHz)	Measure Level (dBuV/m)	Reading Level (dBuV)	Over Limit (dB)	Limit (dBuV/m)	Factor (dB)	Type
1		2390.000	34.527	2.359	-19.473	54.000	32.168	AV
2	*	2404.350	71.510	39.325	17.510	54.000	32.185	AV

Engineer: Allen	
Site: AC5	Time: 2018/05/16 - 16:43
Limit: FCC_Part15.209_RE(3m)	Margin: 0
Probe: Horn_3117_00167055(1-18GHz)	Polarity: Horizontal
EUT: Hue Outdoor Lightstrip 5m	Power: AC 120V/60Hz
Note: Mode 1:Transmit at 2405MHz by zigbee	

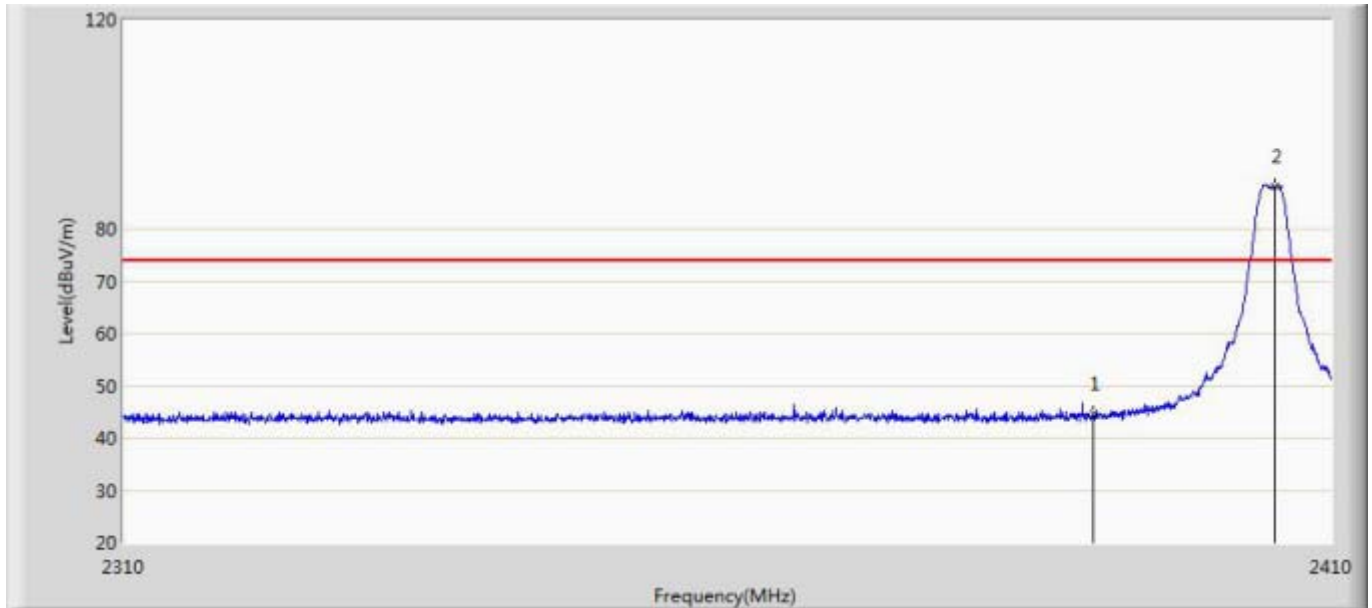

No	Mark	Frequency (MHz)	Measure Level (dBuV/m)	Reading Level (dBuV)	Over Limit (dB)	Limit (dBuV/m)	Factor (dB)	Type
1		2390.000	44.516	12.348	-29.484	74.000	32.168	PK
2	*	2405.300	88.182	55.996	14.182	74.000	32.186	PK

Engineer: Allen	
Site: AC5	Time: 2018/05/16 - 16:44
Limit: FCC_Part15.209_RE(3m)	Margin: 0
Probe: Horn_3117_00167055(1-18GHz)	Polarity: Vertical
EUT: Hue Outdoor Lightstrip 5m	Power: AC 120V/60Hz
Note: Mode 1:Transmit at 2405MHz by zigbee	

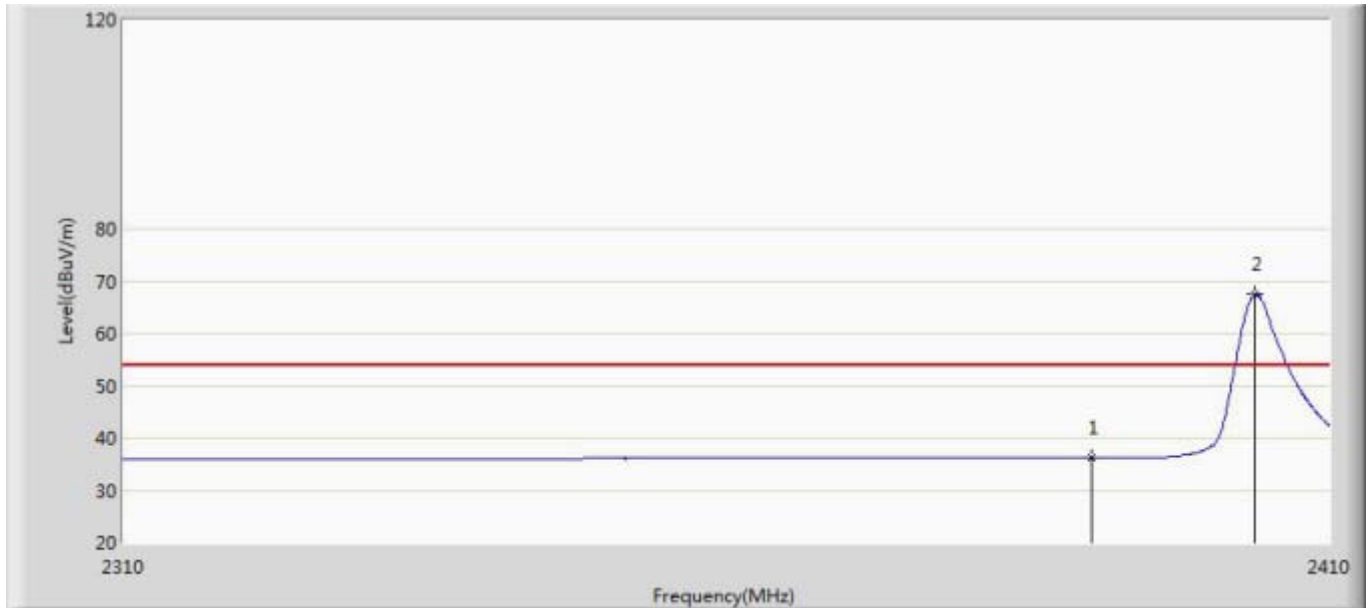

No	Mark	Frequency (MHz)	Measure Level (dBuV/m)	Reading Level (dBuV)	Over Limit (dB)	Limit (dBuV/m)	Factor (dB)	Type
1		2390.000	36.240	4.072	-17.760	54.000	32.168	AV
2	*	2403.700	67.510	35.326	13.510	54.000	32.184	AV

Engineer: Allen	
Site: AC5	Time: 2018/05/16 - 16:45
Limit: FCC_Part15.209_RE(3m)	Margin: 0
Probe: Horn_3117_00167055(1-18GHz)	Polarity: Vertical
EUT: Hue Outdoor Lightstrip 5m	Power: AC 120V/60Hz
Note: Mode 1:Transmit at 2405MHz by zigbee	

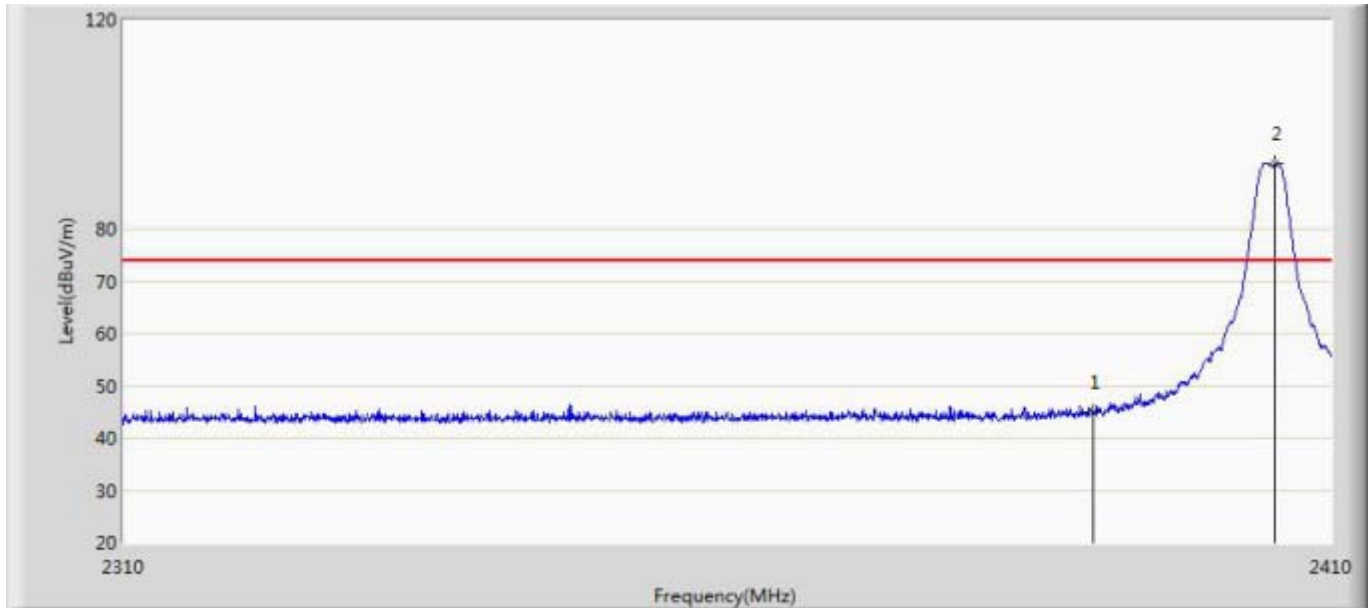

No	Mark	Frequency (MHz)	Measure Level (dBuV/m)	Reading Level (dBuV)	Over Limit (dB)	Limit (dBuV/m)	Factor (dB)	Type
1		2390.000	45.010	12.842	-28.990	74.000	32.168	PK
2	*	2405.300	92.431	60.245	18.431	74.000	32.186	PK

Engineer: Allen	
Site: AC5	Time: 2018/05/16 - 16:56
Limit: FCC_Part15.209_RE(3m)	Margin: 0
Probe: Horn_3117_00167055(1-18GHz)	Polarity: Horizontal
EUT: Hue Outdoor Lightstrip 5m	Power: AC 120V/60Hz
Note: Mode 1:Transmit at 2480MHz by zigbee	

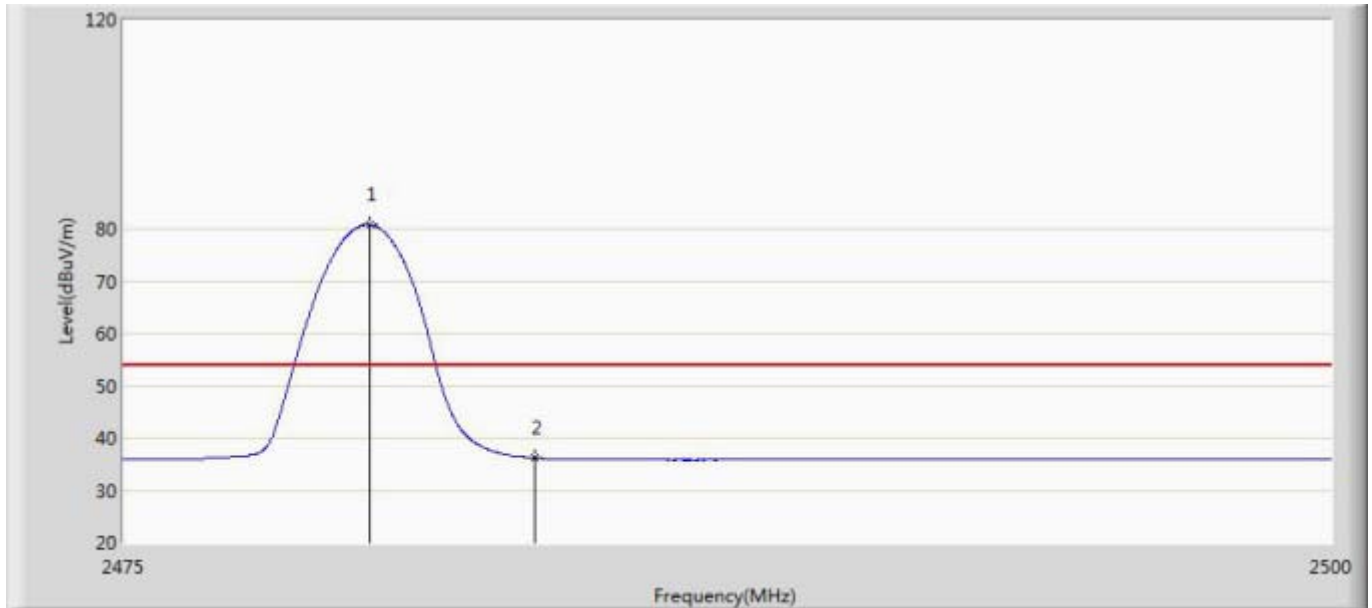

No	Mark	Frequency (MHz)	Measure Level (dBuV/m)	Reading Level (dBuV)	Over Limit (dB)	Limit (dBuV/m)	Factor (dB)	Type
1	*	2480.087	80.739	48.463	26.739	54.000	32.276	AV
2		2483.500	36.174	3.894	-17.826	54.000	32.280	AV



Engineer: Allen	
Site: AC5	Time: 2018/05/16 - 16:57
Limit: FCC_Part15.209_RE(3m)	Margin: 0
Probe: Horn_3117_00167055(1-18GHz)	Polarity: Horizontal
EUT: Hue Outdoor Lightstrip 5m	Power: AC 120V/60Hz
Note: Mode 1:Transmit at 2480MHz by zigbee	

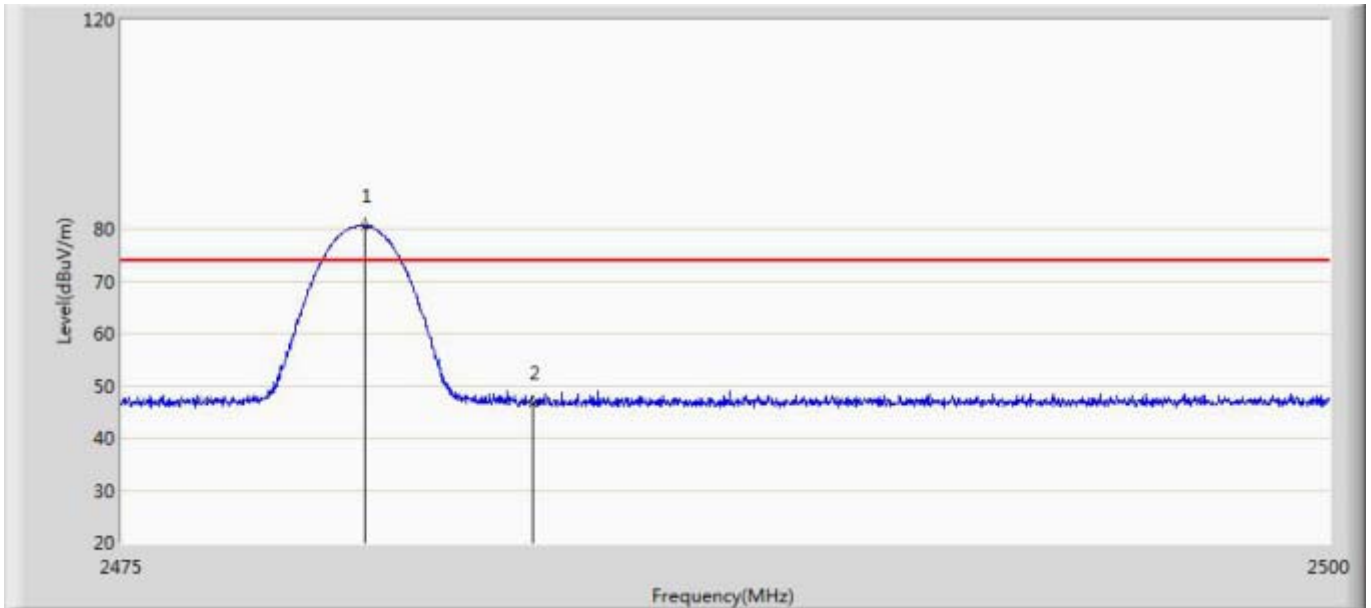

No	Mark	Frequency (MHz)	Measure Level (dBuV/m)	Reading Level (dBuV)	Over Limit (dB)	Limit (dBuV/m)	Factor (dB)	Type
1	*	2480.012	80.532	48.256	6.532	74.000	32.276	PK
2		2483.500	46.645	14.365	-27.355	74.000	32.280	PK

Engineer: Allen	
Site: AC5	Time: 2018/05/16 - 16:58
Limit: FCC_Part15.209_RE(3m)	Margin: 0
Probe: Horn_3117_00167055(1-18GHz)	Polarity: Vertical
EUT: Hue Outdoor Lightstrip 5m	Power: AC 120V/60Hz
Note: Mode 1:Transmit at 2480MHz by zigbee	

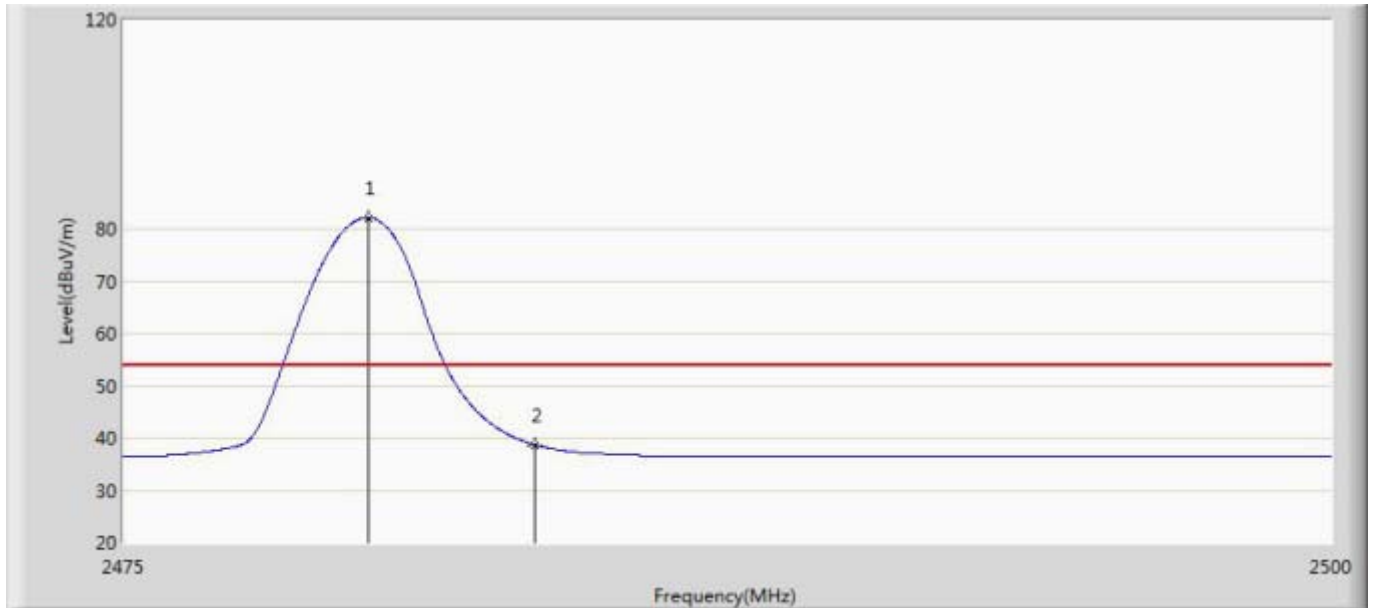

No	Mark	Frequency (MHz)	Measure Level (dBuV/m)	Reading Level (dBuV)	Over Limit (dB)	Limit (dBuV/m)	Factor (dB)	Type
1	*	2480.050	82.141	49.865	28.141	54.000	32.276	AV
2		2483.500	38.666	6.386	-15.334	54.000	32.280	AV

Engineer: Allen	
Site: AC5	Time: 2018/05/16 - 16:59
Limit: FCC_Part15.209_RE(3m)	Margin: 0
Probe: Horn_3117_00167055(1-18GHz)	Polarity: Vertical
EUT: Hue Outdoor Lightstrip 5m	Power: AC 120V/60Hz
Note: Mode 1:Transmit at 2480MHz by zigbee	

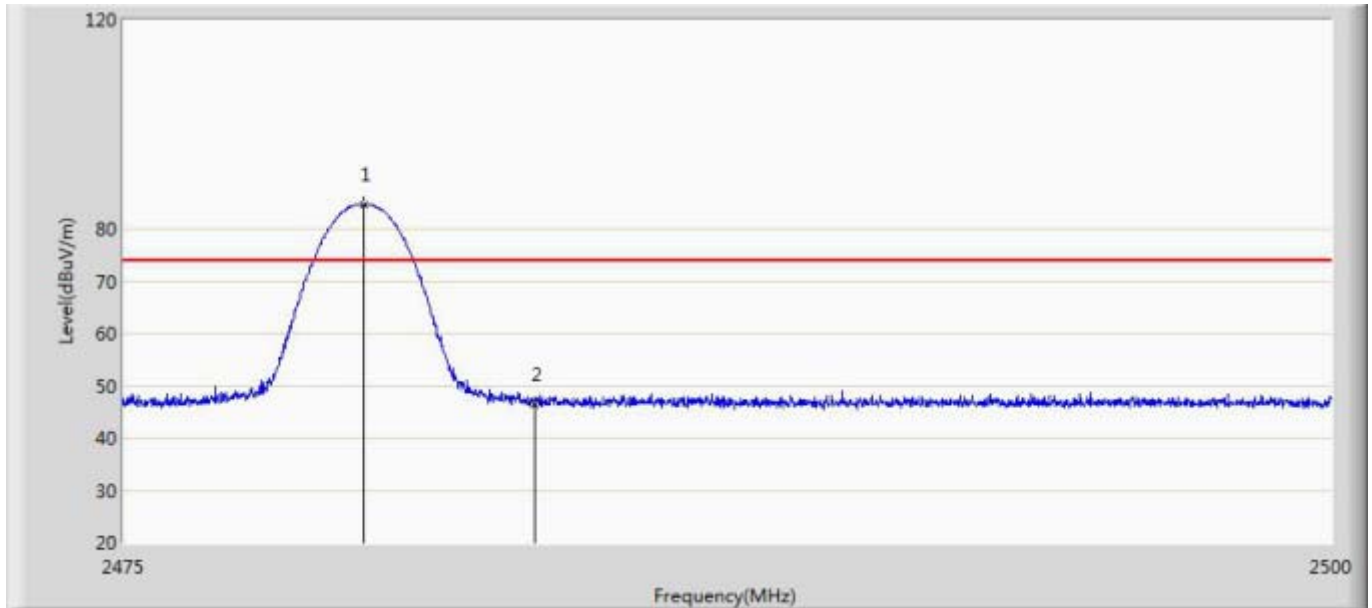

No	Mark	Frequency (MHz)	Measure Level (dBuV/m)	Reading Level (dBuV)	Over Limit (dB)	Limit (dBuV/m)	Factor (dB)	Type
1	*	2479.975	84.701	52.425	10.701	74.000	32.276	PK
2		2483.500	46.464	14.184	-27.536	74.000	32.280	PK

## 7. Occupied Bandwidth

### 7.1. Test Equipment

Occupied Bandwidth / TR-8					
Instrument	Manufacturer	Type No.	Serial No.	Cal. Date	Cal. Due Date
Spectrum Analyzer	Agilent	N9010A	MY48030494	2018.02.04	2019.02.03
EXA Spectrum Analyzer	Keysight	N9010A	MY55370495	2018.04.09	2019.04.08
MXA Signal Analyzer	Keysight	N9020A	MY56060147	2018.04.09	2019.04.08
Temperature/Humidity Meter	zhichen	ZC1-2	TR8-TH	2018.04.10	2019.04.09

Note: All equipment are calibrated with traceable calibrations. Each calibration is traceable to the national or international standards.

### 7.2. Test Setup

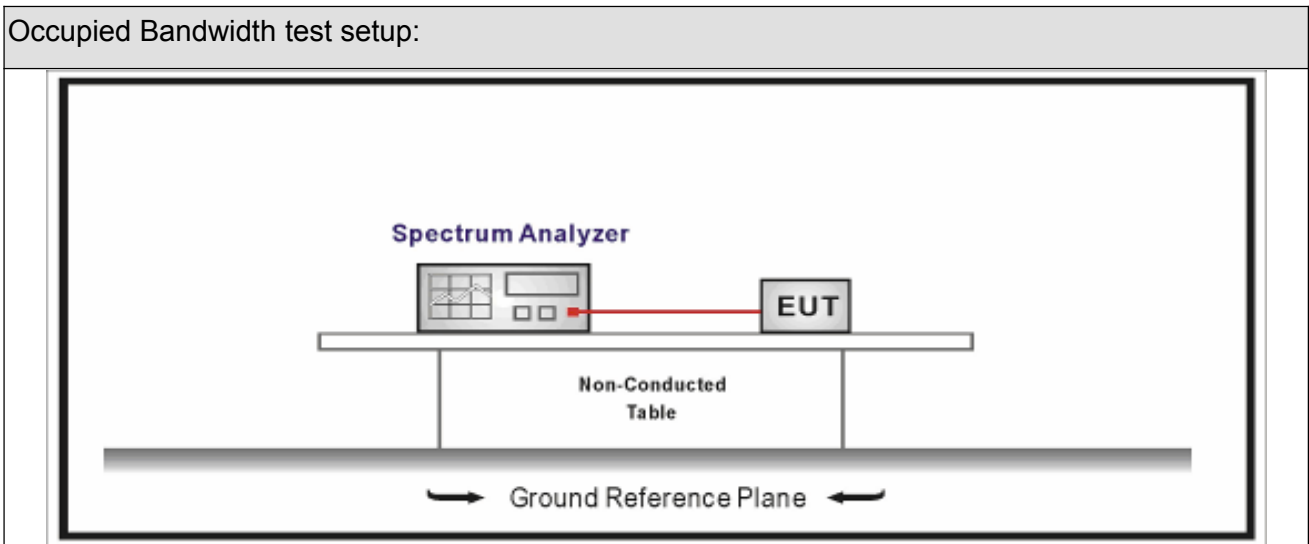



### 7.3. Limit

Occupied Bandwidth
Systems using digital modulation techniques operate in the 2400-2483.5 MHz. The minimum 6 dB bandwidth shall be at least 500 kHz

### 7.4. Test Procedure

Test Method			
	Reference Rule	Chapter	Description
<input checked="" type="checkbox"/>	ANSI C63.10	11.8	DTS bandwidth
<input type="checkbox"/>	ANSI C63.10	11.8.1	Option 1
<input checked="" type="checkbox"/>	ANSI C63.10	11.8.2	Option 2

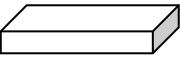
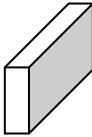
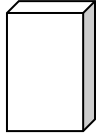
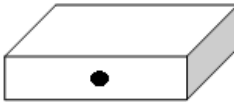
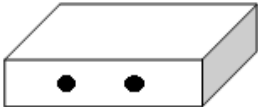
**7.5. EUT test definition**

Item	Occupied Bandwidth			
Device Category	<input type="checkbox"/>	Fixed point-to-point		
	<input type="checkbox"/>	Emit multiple directional beams, simultaneously or sequentially		
	<input checked="" type="checkbox"/>	Other cases		
Test mode	Mode 1			
Test method	<input type="checkbox"/>	Radiated		
		X Axis	Y Axis	Z Axis
				
		Worst Axis <input type="checkbox"/>	Worst Axis <input type="checkbox"/>	Worst Axis <input type="checkbox"/>
	<input checked="" type="checkbox"/>	Conducted		
	<input checked="" type="checkbox"/>	Chain 0		
				
	<input type="checkbox"/>	Chain 0	Chain 1	
				
	<input type="checkbox"/>	Chain 0	Chain 1	Chain 2
				

### 7.6. Test Result

Product Name	: Hue Outdoor Lightstrip 5m	Power	: AC 120V/60Hz
Test Mode	: Mode 1	Test Site	: TR-8
Test Date	: 2018.05.30	Test engineer	: Allen

Mode	CH.	Test Freq. (MHz)	99% Occupied Bandwidth (kHz)	6dB Occupied Bandwidth (kHz)	Limit (kHz)	Result
1	11	2405	2391.9	1506	>500	Pass
1	20	2450	2387.5	1514	>500	Pass
1	26	2480	2451	1504	>500	Pass

Note : The worst case of Occupied Bandwidth as below:

#### Mode 1 CH26 (2480MHz)



## 8. Fundamental emission output power

### 8.1. Test Equipment

Fundamental emission output power/ TR-8					
Instrument	Manufacturer	Type No.	Serial No.	Cal. Date	Cal. Due Date
Spectrum Analyzer	Agilent	E4446A	MY45300103	2018.01.04	2019.01.03
Spectrum Analyzer	Agilent	N9010A	MY48030494	2018.01.04	2019.01.03
Wideband Peak Power Meter	Anritsu	ML2495A	0905006	2017.10.14	2018.10.13
Power Sensor	Anritsu	MA2411B	0846014	2017.10.14	2018.10.13
Temperature/Humidity Meter	zhicheng	ZC1-2	TR8-TH	2018.04.10	2019.04.09

Note: All equipment are calibrated with traceable calibrations. Each calibration is traceable to the national or international standards.

### 8.2. Test Setup

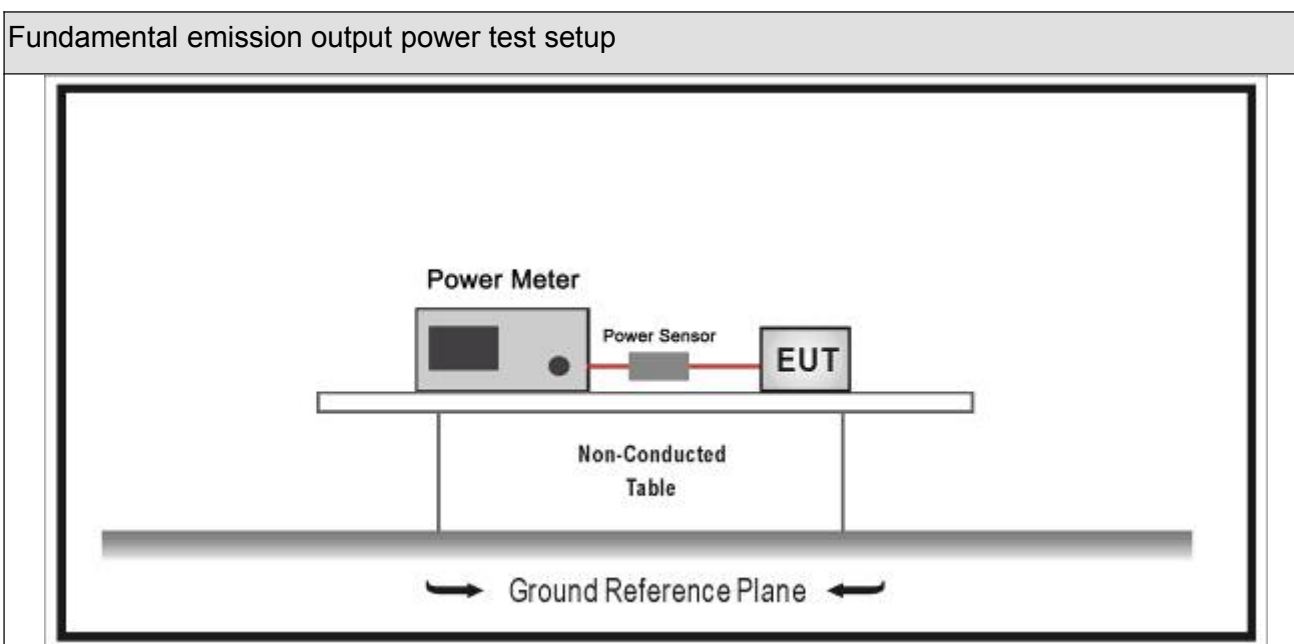







### 8.3. Limit

Fundamental emission output power Limit		
<input type="checkbox"/>	$G_{TX} < 6\text{dBi}$	$P_{out} \leq 30\text{dBm}$
<input checked="" type="checkbox"/>	$G_{TX} > 6\text{dBi}$	
<input type="checkbox"/>	Non-Fix point-point	$P_{out} \leq 30 - (G_{TX} - 6)$
<input type="checkbox"/>	Fix point-point	$P_{out} \leq 30 - [(G_{TX} - 6)]/3$
<input checked="" type="checkbox"/>	Point-to-multipoint	$P_{out} \leq 30 - (G_{TX} - 6)$
<input type="checkbox"/>	Overlap Beams	$P_{out} \leq 30 - [(G_{TX} - 6)]/3$
<input type="checkbox"/>	Aggregate power transmitted simultaneously on all beams	$P_{out} \leq 30 - [(G_{TX} - 6)]/3$
<input type="checkbox"/>	single directional beam	$P_{out} \leq 30 - [(G_{TX} - 6)]/3 + 8\text{dB}$
<p>Note 1 : <math>G_{TX}</math> directional gain of transmitting antennas.</p> <p>Note 2 : <math>P_{out}</math> is maximum peak conducted output power .</p>		

### 8.4. Test Procedure

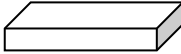
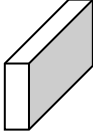
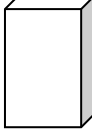
Fundamental emission output power Test Method				
	References Rule		Chapter	Description
<input checked="" type="checkbox"/>	ANSI C63.10		11.9	Fundamental emission output power
	<input checked="" type="checkbox"/>	ANSI C63.10	11.9.1	Maximum peak conducted output power
	<input type="checkbox"/>	ANSI C63.10	11.9.1.1	RBW $\geq$ DTS bandwidth
	<input type="checkbox"/>	ANSI C63.10	11.9.1.2	Integrated band power method
	<input checked="" type="checkbox"/>	ANSI C63.10	11.9.1.3	PKPM1 Peak power meter method
	<input type="checkbox"/>	ANSI C63.10	11.9.2	Maximum conducted (average) output power
	<input type="checkbox"/>	ANSI C63.10	11.9.2.2	Measurement using a spectrum analyzer (SA)
	<input type="checkbox"/>	ANSI C63.10	11.9.2.2.2	Method AVGSA-1(Duty cycle $\geq$ 98%)
	<input type="checkbox"/>	ANSI C63.10	11.9.2.2.3	Method AVGSA-1A(Duty cycle $\geq$ 98%)
	<input type="checkbox"/>	ANSI C63.10	11.9.2.2.4	Method AVGSA-2(Duty cycle $\leq$ 98%)
	<input type="checkbox"/>	ANSI C63.10	11.9.2.2.5	Method AVGSA-2A(Duty cycle $\leq$ 98%)
	<input type="checkbox"/>	ANSI C63.10	11.9.2.2.4	Method AVGSA-3
	<input type="checkbox"/>	ANSI C63.10	11.9.2.2.5	Method AVGSA-3A
	<input type="checkbox"/>	ANSI C63.10	11.9.2.3	Measurement using a power meter (PM)
	<input type="checkbox"/>	ANSI C63.10	11.9.2.3.1	Method AVGPM
	<input type="checkbox"/>	ANSI C63.10	11.9.2.3.2	Method AVGPM-G

**8.5. EUT test definition**

Item	Fundamental emission output power			
Device Category	<input type="checkbox"/>	Fixed point-to-point		
	<input type="checkbox"/>	Emit multiple directional beams, simultaneously or sequentially		
	<input checked="" type="checkbox"/>	Other cases		
Test mode	Mode 1			
Test method	<input type="checkbox"/>	Radiated		
		X Axis	Y Axis	Z Axis
				
		Worst Axis <input type="checkbox"/>	Worst Axis <input type="checkbox"/>	Worst Axis <input type="checkbox"/>
	<input checked="" type="checkbox"/>	Conducted		
	<input checked="" type="checkbox"/>	Chain 0		
				
	<input type="checkbox"/>	Chain 0	Chain 1	
				
	<input type="checkbox"/>	Chain 0	Chain 1	Chain 2
				

**8.6. Test Result**

Product Name	: Hue Outdoor Lightstrip 5m	Power	: AC 120V/60Hz
Test Mode	: Mode 1	Test Site	: TR-8
Test Date	: 2018.05.21	Test engineer	: Allen

Mode	Channel	Test Frequency (MHz)	Measurement Power Output (dBm)	Limit (dBm)	Result
1	11	2405	0.02	29.81	Pass
1	20	2450	-0.03	29.81	Pass
1	26	2480	-0.12	29.81	Pass

## 9. Power Spectral Density

### 9.1. Test Equipment

Power Spectral Density / TR-8					
Instrument	Manufacturer	Type No.	Serial No.	Cal. Date	Cal. Due Date
Spectrum Analyzer	Agilent	N9010A	MY48030494	2018.02.04	2019.02.03
EXA Spectrum Analyzer	Keysight	N9010A	MY55370495	2018.04.09	2019.04.08
MXA Signal Analyzer	Keysight	N9020A	MY56060147	2018.04.09	2019.04.08
Temperature/Humidity Meter	zhichen	ZC1-2	TR8-TH	2018.04.10	2019.04.09

Note: All equipment are calibrated with traceable calibrations. Each calibration is traceable to the national or international standards.

### 9.2. Test Setup

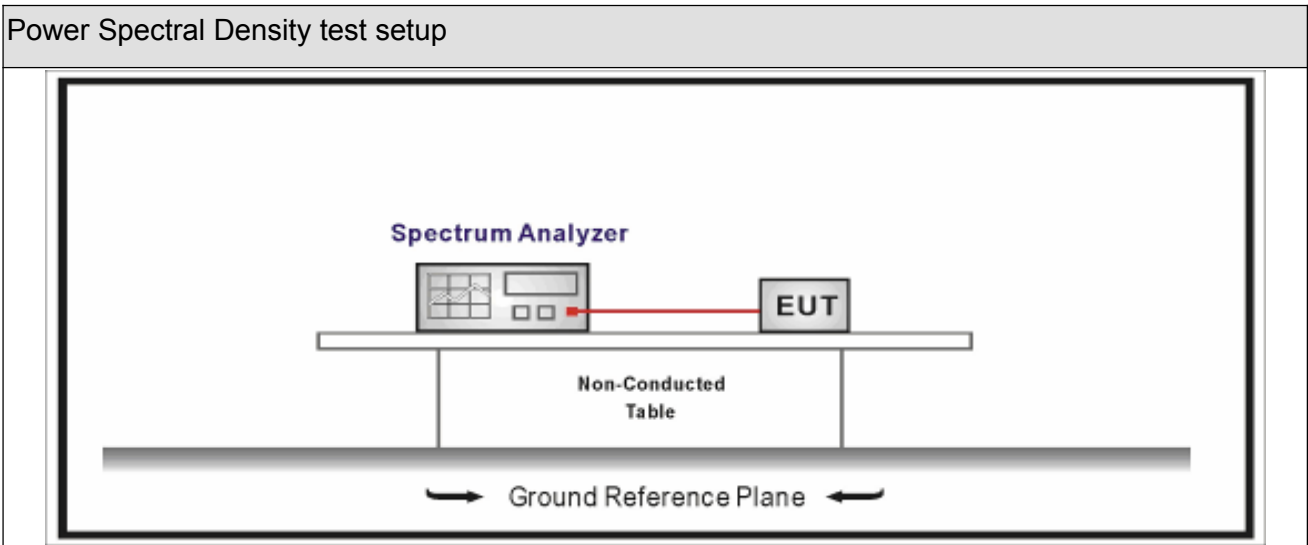

### 9.3. Limit

Power Spectral Density Limit
Power Spectral Density $\leq 8\text{dBm}/3\text{kHz}$

### 9.4. Test Procedure

Power Spectral Density Test Method			
	References Rule	Chapter	Description
<input checked="" type="checkbox"/>	ANSI C63.10	11.10	Maximum power spectral density level in the fundamental emission
<input checked="" type="checkbox"/>	ANSI C63.10	11.10.2	Method PKPSD (peak PSD)
<input type="checkbox"/>	ANSI C63.10	11.10.3	Method AVGPSD-1(Duty cycle $\geq$ 98%)
<input type="checkbox"/>	ANSI C63.10	11.10.4	Method AVGPSD-1A(Duty cycle $\geq$ 98%)
<input type="checkbox"/>	ANSI C63.10	11.10.5	Method AVGPSD-2(Duty cycle $<$ 98%)
<input type="checkbox"/>	ANSI C63.10	11.10.6	Method AVGPSD-2A(Duty cycle $<$ 98%)
<input type="checkbox"/>	ANSI C63.10	11.10.7	Method AVGPSD-3
<input type="checkbox"/>	ANSI C63.10	11.10.8	Method AVGPSD-3A

**9.5. EUT test definition**

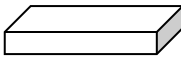
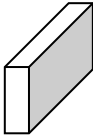
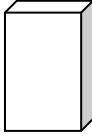
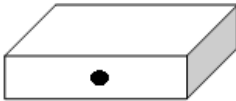
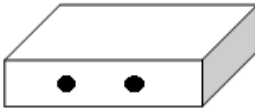
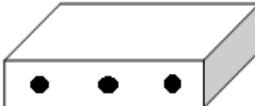
Item	Power Spectral Density Test Method			
Device Category	<input type="checkbox"/>	Fixed point-to-point		
	<input type="checkbox"/>	Emit multiple directional beams, simultaneously or sequentially		
	<input checked="" type="checkbox"/>	Other cases		
Test mode	Mode 1			
Test method	<input type="checkbox"/>	Radiated		
		X Axis	Y Axis	Z Axis
				
		Worst Axis <input type="checkbox"/>	Worst Axis <input type="checkbox"/>	Worst Axis <input type="checkbox"/>
	<input checked="" type="checkbox"/>	Conducted		
	<input checked="" type="checkbox"/>	Chain 0		
				
	<input type="checkbox"/>	Chain 0	Chain 1	
				
	<input type="checkbox"/>	Chain 0	Chain 1	Chain 2
				

### 9.6. Test Result

Product Name	: Hue Outdoor Lightstrip 5m	Power	: AC 120V/60Hz
Test Mode	: Mode 1	Test Site	: TR-8
Test Date	: 2018.05.30	Test engineer	: Allen

Mode	Channel	Test Frequency (MHz)	Measurement PSD (dBm/3kHz)	Total PSD (dBm/3kHz)	Limit (dBm/3kHz)	Result
1	11	2405	1.483	1.483	7.81	Pass
1	15	2425	1.319	1.319	7.81	Pass
1	20	2450	1.075	1.075	7.81	Pass
1	25	2475	0.529	0.529	7.81	Pass
1	26	2480	-7.905	-7.905	7.81	Pass

Note : The worst case of Power Spectral Density as below:

**Mode 1 CH11(2405MHz)**





## 10. Antenna Requirement

### 10.1. Limit

Antenna Requirement Limit
<p>An intentional radiator shall be designed to ensure that no antenna other than that furnished by the responsible party shall be used with the device. The use of a permanently attached antenna or of an antenna that uses a unique coupling to the intentional radiator shall be considered sufficient to comply with the provisions of this section. The manufacturer may design the unit so that a broken antenna can be replaced by the user, but the use of a standard antenna jack or electrical connector is prohibited. This requirement does not apply to carrier current devices or to devices operated under the provisions of §15.211, §15.213, §15.217, §15.219, or §15.221. Further, this requirement does not apply to intentional radiators that must be professionally installed, such as perimeter protection systems and some field disturbance sensors, or to other intentional radiators which, in accordance with §15.31(d), must be measured at the installation site. However, the installer shall be responsible for ensuring that the proper antenna is employed so that the limits in this part are not exceeded.</p>

### 10.2. Antenna Connector Construction

Antenna Connector Construction	
<input checked="" type="checkbox"/>	The use of a permanently attached antenna
<input type="checkbox"/>	The antenna use of a unique coupling to the intentional radiator
<input type="checkbox"/>	The use of a nonstandard antenna jack or electrical connector
Please refer to the attached document "Internal Photograph" to show the antenna connector.	

\_\_\_\_\_ The End \_\_\_\_\_