



Test Report

FCC Part15 Subpart C & ISED RSS-247 Issue 2

Product Name : LED lamp
Model No. : 9290012575B
FCC ID : 2AGBW9290012575BX
IC : 20812-2575BX

Applicant : Philips Lighting (China) Investment Co., Ltd.
Address : Building 9, Lane 888, Tianlin Road, Minhang district,
Shanghai, China

Date of Receipt : Aug. 30, 2017
Test Date : Aug. 30, 2017~ Jan. 11, 2018
Issued Date : Jan. 23, 2018
Report No. : 1782158R-RF-US-P06V02
Report Version : V 1.0

The test results relate only to the samples tested.

The test results shown in the test report are traceable to the national/international standard through the calibration of the equipment and evaluated measurement uncertainty herein.

This report must not be used to claim product endorsement by TAF, A2LA or any agency of the government.

The test report shall not be reproduced without the written approval of DEKRA Testing & Certification (Suzhou) Co., Ltd.

Test Report Certification

Issued Date : Jan. 23, 2018
Report No. : 1782158R-RF-US-P06V02



Product Name : LED lamp
 Applicant : Philips Lighting (China) Investment Co., Ltd.
 Address : Building 9, Lane 888, Tianlin Road, Minhang district, Shanghai, China
 Manufacturer : Philips Lighting (China) Investment Co., Ltd.
 Address : Building 9, Lane 888, Tianlin Road, Minhang district, Shanghai, China
 Model No. : 9290012575B
 FCC ID : 2AGBW9290012575BX
 IC : 20812-2575BX
 Brand Name : Philips
 EUT Voltage : 110 ~ 130Vac, 9.5W, 50-60Hz
 Test Voltage : AC 120V/60Hz
 Applicable Standard : FCC CFR Title 47 Part 15 Subpart C: 2016
 ANSI C63.4:2014; ANSI C63.10:2013;
 KDB 558074 D01v04
 ISED RSS-Gen Issue 4 / RSS-247 Issue 2
 Test Result : Complied
 Performed Location : DEKRA Testing & Certification (Suzhou) Co., Ltd.
 No.99 Hongye Rd., Suzhou Industrial Park, Suzhou, 215006, Jiangsu, China
 TEL: +86-512-6251-5088 / FAX: +86-512-6251-5098
 FCC Registration Number: CN1199; IC Lab Code: 4075B

Documented By : Kathy Feng
 (Project Assistant: Kathy Feng)

Reviewed By : Frank He
 (Senior Project Manager: Frank He)

Approved By : Harry Zhao
 (Engineering Manager: Harry Zhao)

TABLE OF CONTENTS

Description	Page
1. General Information	6
1.1. EUT Description	6
1.2. Working Frequency of Each Channel:	6
1.3. Antenna information	7
1.4. Mode of Operation.....	8
1.5. Tested System Details	8
1.6. Configuration of Tested System.....	9
1.7. EUT Exercise Software.....	10
2. Technical Test	11
2.1. Summary of Test Result.....	11
2.2. Test Environment.....	13
2.3. Measurement Uncertainty.....	13
3. AC Power Line Conducted Emission	14
3.1. Test Equipment.....	14
3.2. Test Setup.....	14
3.3. Limit.....	15
3.4. Test Procedure	15
3.5. Test Result.....	16
4. Emissions in restricted frequency bands	26
4.1. Test Equipment.....	26
4.2. Test Setup.....	27
4.3. Limit.....	28
4.4. Test Procedure	31
4.5. EUT test Axis definition.....	32
4.6. Test Result.....	33
5. Emissions in non-restricted frequency bands	57
5.1. Test Equipment.....	57
5.2. Test Setup.....	57
5.3. Limit.....	58
5.4. Test Procedure	59
5.5. EUT test Axis definition.....	60
5.6. Test Result.....	61
6. Radiated Emission Band Edge	62
6.1. Test Equipment.....	62
6.2. Test Setup.....	63
6.3. Limit.....	63
6.4. Test Procedure	64

- 6.5. EUT test definition 65
- 6.6. Duty Cycle 66
- 6.7. Test Result 67
- 7. Occupied Bandwidth 103
 - 7.1. Test Equipment..... 103
 - 7.2. Test Setup..... 103
 - 7.3. Limit..... 104
 - 7.4. Test Procedure 104
 - 7.5. EUT test definition 105
 - 7.6. Test Result..... 106
- 8. Fundamental emission output power 107
 - 8.1. Test Equipment..... 107
 - 8.2. Test Setup..... 107
 - 8.3. Limit..... 108
 - 8.4. Test Procedure 109
 - 8.5. EUT test definition 110
 - 8.6. Test Result..... 111
- 9. Power Spectral Density 112
 - 9.1. Test Equipment..... 112
 - 9.2. Test Setup..... 112
 - 9.3. Limit..... 112
 - 9.4. Test Procedure 113
 - 9.5. EUT test definition 114
 - 9.6. Test Result..... 115
- 10. Antenna Requirement..... 116
 - 10.1. Limit..... 116
 - 10.2. Antenna Connector Construction..... 116

History of This Test Report

REPORT NO.	VERSION	DESCRIPTION	ISSUED DATE
1782158R-RF-US-P06V02	V1.0	Initial Issued Report	Jan. 23, 2018

1. General Information

1.1. EUT Description

Product Name	LED Lamp
Brand Name	Philips
Model No.	9290012575B
EUT Voltage	110 ~ 130Vac, 9.5W, 50-60Hz
Frequency Range	2405 ~ 2480MHz
Channel Number	16
Type of Modulation	O-QPSK
Data Rate	250kbps
Antenna Type	Reference to Antenna List
Peak Antenna Gain	Reference to Antenna List

1.2. Working Frequency of Each Channel:

Zigbee Working Frequency of Each Channel:							
Channel	Frequency	Channel	Frequency	Channel	Frequency	Channel	Frequency
11	2405 MHz	12	2410 MHz	13	2415 MHz	14	2420 MHz
15	2425 MHz	16	2430 MHz	17	2435 MHz	18	2440 MHz
19	2445 MHz	20	2450 MHz	21	2455 MHz	22	2460 MHz
23	2465 MHz	24	2470 MHz	25	2475 MHz	26	2480 MHz

1.3. Antenna information

Antenna manufacturer	N/A		
Antenna Delivery	<input checked="" type="checkbox"/> 1*TX+1*RX	<input type="checkbox"/> 2*TX+2*RX	<input type="checkbox"/> 3*TX+3*RX
Antenna technology	<input checked="" type="checkbox"/> SISO		
	<input type="checkbox"/> MIMO	<input type="checkbox"/> Basic	
		<input type="checkbox"/> CDD	
		<input type="checkbox"/> Beam-forming	
Antenna Type	<input type="checkbox"/> External	<input type="checkbox"/> Dipole	
	<input checked="" type="checkbox"/> Internal	<input type="checkbox"/> PIFA	
		<input checked="" type="checkbox"/> PCB	
		<input type="checkbox"/> Ceramic Chip Antenna	
		<input type="checkbox"/> Metal plate type F antenna	
Antenna Gain	-1.22dBi		

1.4. Mode of Operation

DEKRA has verified the construction and function in typical operation. See the different modes shown in this test report and defined as:

Test Modes List
Mode 1: Transmit by Zigbee

1.5. Tested System Details

The types for all equipment, plus descriptions of all cables used in the tested system (including inserted cards) are:

No.	Product	Manufacturer	Model No.	Serial No.	Power Cord
1	Notebook	Think Pad	2526	LV-A3285	Power by adapter
2	Control board	Philips	N/A	N/A	N/A
A	USB Control Cable	N/A	N/A	N/A	Shield, 1m
B	USB Control Cable	N/A	N/A	N/A	Shield, 10m

1.6. Configuration of Tested System

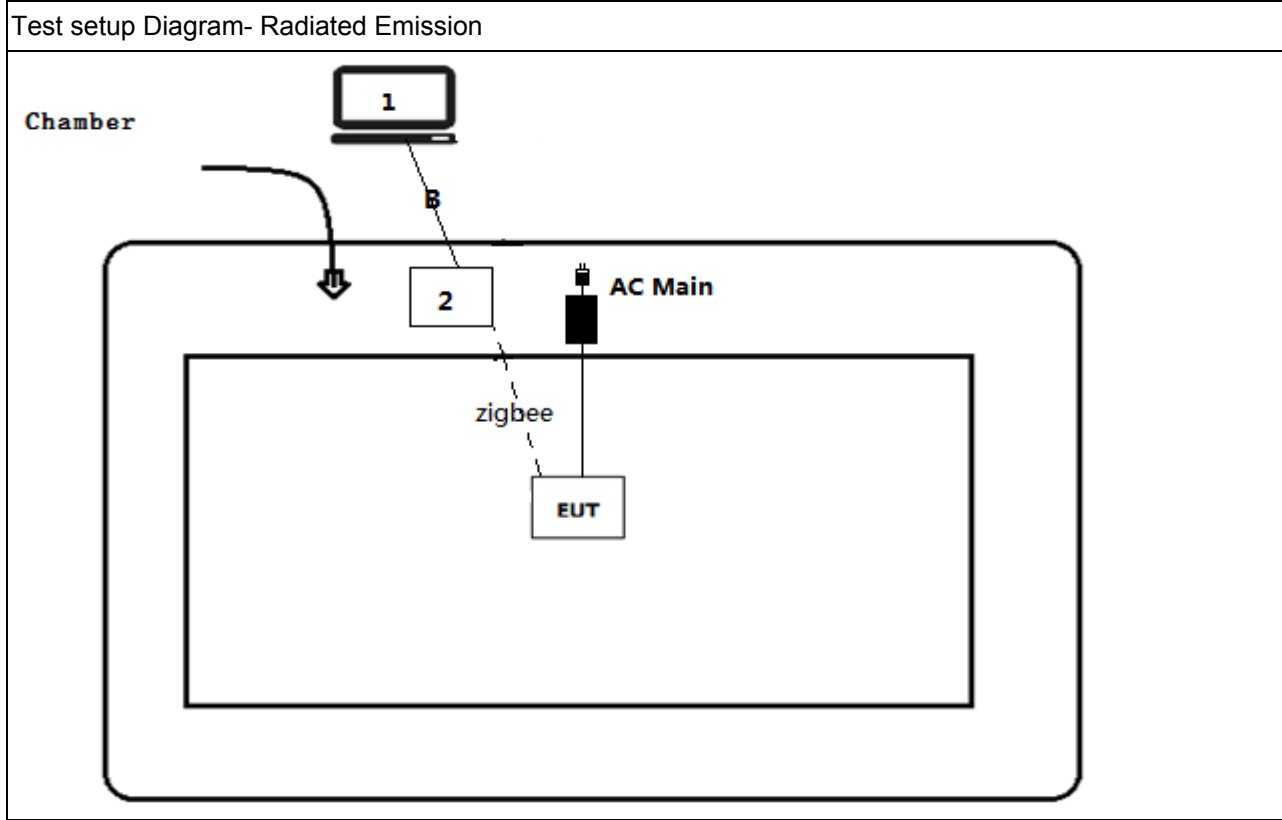
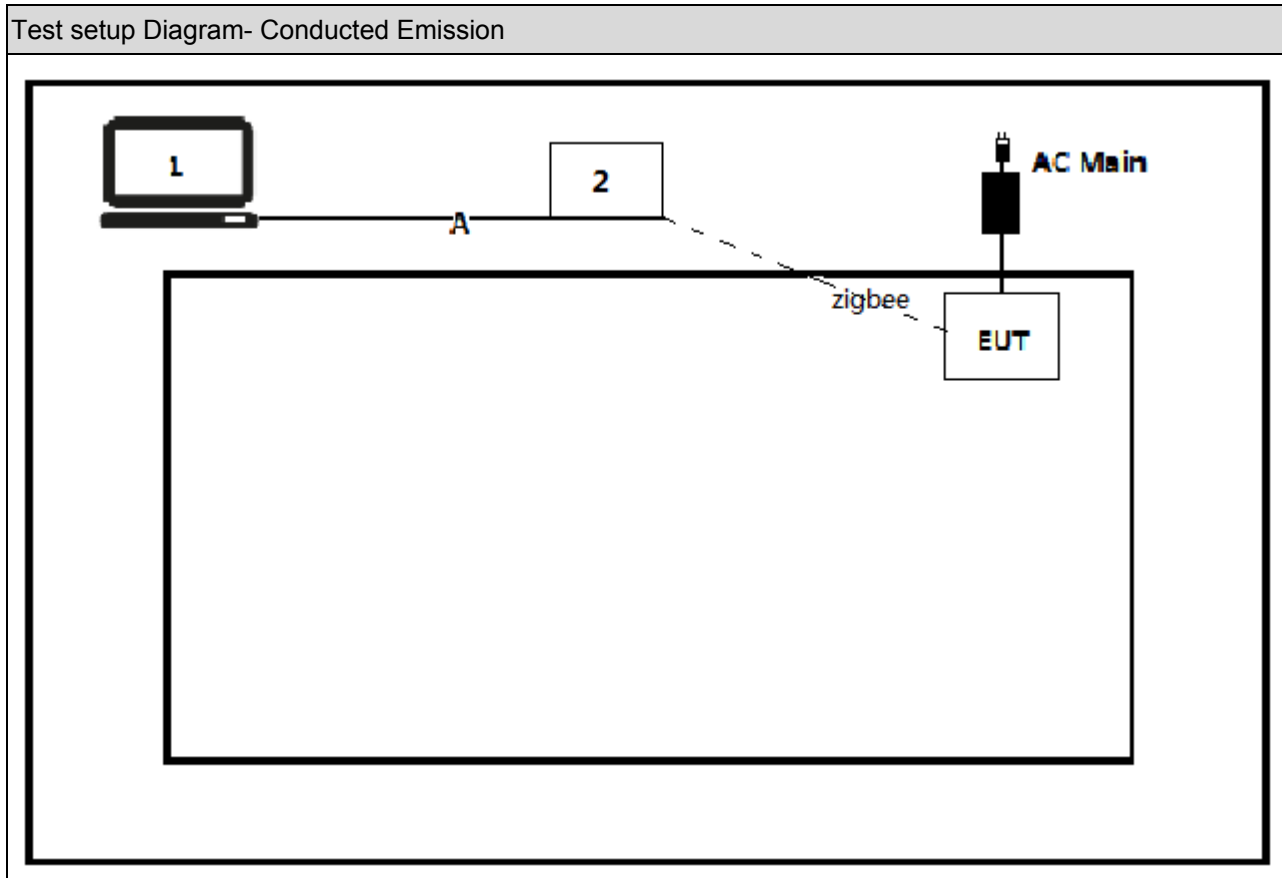

1.7. EUT Exercise Software

1	Setup the EUT and simulators as shown on above.
2	Turn on the power of all equipment.
3	Run the software, and set the test mode and channel, then press OK to start continue receive.

2. Technical Test

2.1. Summary of Test Result

For FCC rule

Performed Test Item	Normative References	Limit	Result
AC Power Line Conducted Emission	FCC CFR Title 47 Part 15 Subpart C: 2016 Section 15.207	FCC 15.207	PASS
Emissions in restricted frequency bands	FCC CFR Title 47 Part 15 Subpart C: 2016 Section 15.209	FCC 15.209	PASS
Emissions in non-restricted frequency bands	FCC CFR Title 47 Part 15 Subpart C: 2016 Section 15.247(d)	20dBc	PASS
Radiated Emission Band Edge	FCC CFR Title 47 Part 15 Subpart C: 2016 15.247(d)	FCC 15.209	PASS
Occupied Bandwidth	FCC CFR Title 47 Part 15 Subpart C: 2016 Section 15.247(a)(2)	500kHz	PASS
Fundamental emission output power	FCC CFR Title 47 Part 15 Subpart C: 2016 Section 15.247(b)(3)	30dBm	PASS
Power Spectral Density	FCC CFR Title 47 Part 15 Subpart C: 2016 Section 15.247(e)	8dBm/3kHz	PASS
Antenna Requirement	FCC CFR Title 47 Part 15 Subpart C: 2016 Section 15.203	FCC 15.203	PASS

For IC rule

Performed Test Item	Normative References	Limit	Result
AC Power Line Conducted Emission	RSS-Gen Issue 4 Section 8.8	RSS-Gen	PASS
Emissions in restricted frequency bands	RSS-Gen Issue 4 Section 8.9	RSS-Gen	PASS
Emissions in non-restricted frequency bands	RSS-247 Issue 2 Section A5.5	20dBc	PASS
Radiated Emission Band Edge	RSS-247 Issue 2 Section A5.5	RSS-247	PASS
Occupied Bandwidth	RSS-Gen Issue 4 Section 6.6 RSS-247 Issue 2 Section A5.2(1)	500kHz	PASS
Fundamental emission output power	RSS-247 Issue 2 Section A5.4(4)	30dBm	PASS
Power Spectral Density	RSS-247 Issue 2 Section A5.2(2)	8dBm/3kHz	PASS
Antenna Requirement	RSS-Gen Issue 4 Section 8.3	RSS-Gen Issue 4	PASS

2.2. Test Environment

Items	Required (IEC 68-1)	Actual
Temperature (°C)	15-35	21
Humidity (%RH)	25-75	50
Barometric pressure (mbar)	860-1060	950-1000

2.3. Measurement Uncertainty

Test Items	Uncertainty
AC Power Line Conducted Emission	$\pm 2.02\text{dB}$
Radiated Emission	Below 1GHz $\pm 3.8\text{ dB}$
	Above 1GHz $\pm 3.9\text{ dB}$
RF Antenna Port Conducted Emission	$\pm 1.27\text{dB}$
Radiated Emission Band Edge	$\pm 3.9\text{dB}$
Occupied Bandwidth	$\pm 1\text{kHz}$
Power Spectral Density	$\pm 1.27\text{dB}$

3. AC Power Line Conducted Emission

3.1. Test Equipment

AC Power Line Conducted Emission / TR-1					
Instrument	Manufacturer	Type No.	Serial No.	Cal. Date	Cal. Due Date
EMI Test Receiver	R&S	ESCI	100906	2017.03.05	2018.03.04
Two-Line V-Network	R&S	ENV 216	101189	2017.07.16	2018.07.15
Two-Line V-Network	R&S	ENV 216	101044	2017.09.16	2018.09.15
50ohm Coaxial Switch	Anritsu	MP59B	6200464462	N/A	N/A
50ohm Termination	SHX	TF2	07081402	2017.09.16	2018.09.15
Temperature/Humidity Meter	Zhichen	ZC1-2	TR1-TH	2017.01.04	2019.01.03

Note: All equipment are calibrated with traceable calibrations. Each calibration is traceable to the national or international standards.

3.2. Test Setup

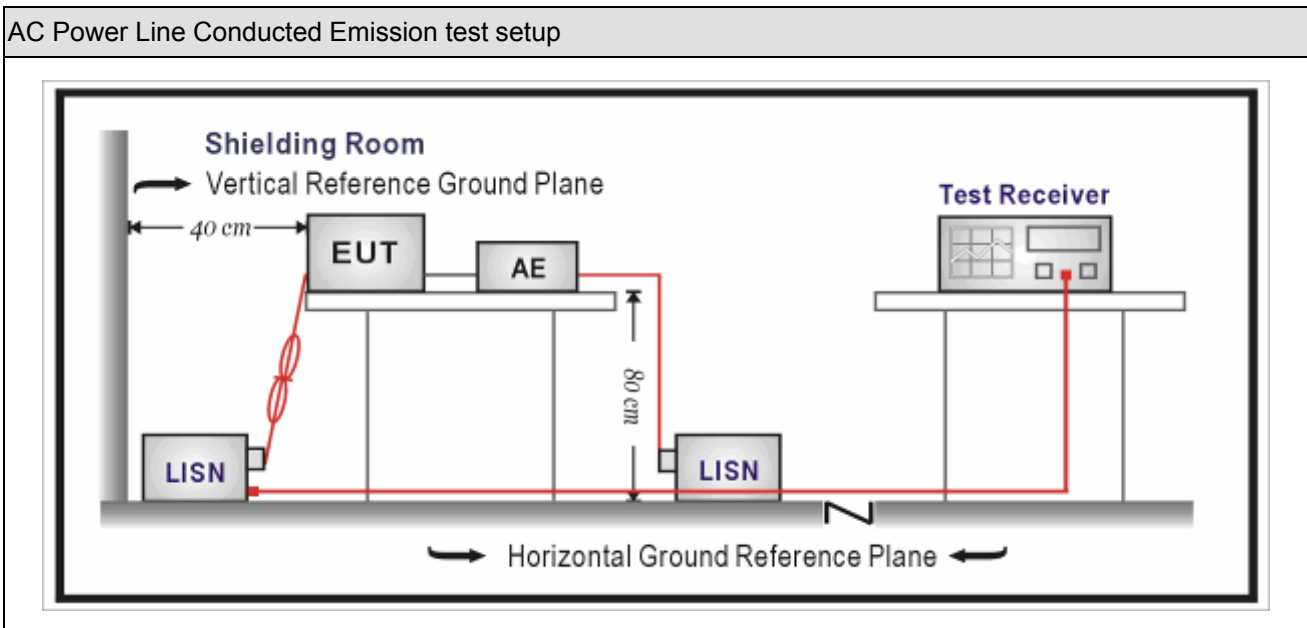

3.3. Limit

Frequency of Emission (MHz)	Conducted Limit	
	Quasi-peak (dB μ V)	Average (dB μ V)
0.15-0.5	66 to 56	56 to 46
0.5-5	56	46
5-30	60	50

Note 1: The lower limit shall apply at the transition frequencies.
 Note 2: The limit decreases linearly with the logarithm of the frequency in the range 0.15 MHz to 0.5 MHz.

3.4. Test Procedure

Test Method			
	References Rule	Chapter	Item
<input checked="" type="checkbox"/>	ANSI C63.10-2013	6.2	Standard test method for ac power-line conducted emissions from unlicensed wireless devices
<input checked="" type="checkbox"/>	ANSI C63.4-2014	7	AC power-line conducted emission measurements

3.5. Test Result

The result for APT+Alvis+Diodes:

Engineer: Nino	
Site: TR1	Time: 2017/09/08 - 10:20
Limit: FCC_Part15.107_CE_AC Power_ClassB	Margin: 0
Probe: ENV216_101190(0.009-30MHz)	Polarity: Line
EUT: LED Lamp	Power: AC 120V/60Hz
Note: Mode 1:Transmit at2405MHz by zigbee	

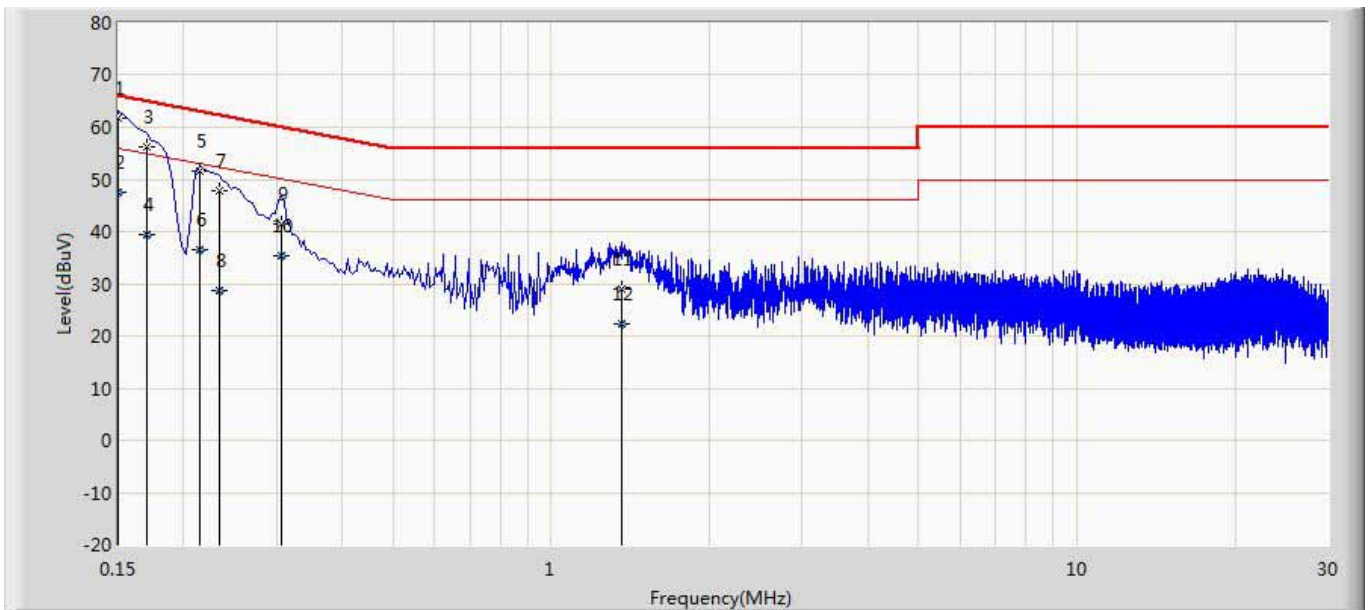

No	Mark	Frequency (MHz)	Measure Level (dBuV)	Reading Level (dBuV)	Over Limit (dB)	Limit (dBuV)	Probe (dB)	Cable (dB)	Amp (dB)	Type
1	*	0.150	61.660	52.025	-4.340	66.000	9.610	0.025	0.000	QP
2		0.150	47.474	37.840	-8.526	56.000	9.610	0.025	0.000	AV
3		0.170	56.376	46.743	-8.584	64.960	9.606	0.027	0.000	QP
4		0.170	39.370	29.738	-15.590	54.960	9.606	0.027	0.000	AV
5		0.214	51.512	41.882	-11.537	63.049	9.600	0.029	0.000	QP
6		0.214	36.491	26.861	-16.558	53.049	9.600	0.029	0.000	AV
7		0.234	47.759	38.130	-14.547	62.307	9.600	0.030	0.000	QP
8		0.234	28.752	19.122	-23.555	52.307	9.600	0.030	0.000	AV
9		0.306	41.506	31.872	-18.572	60.078	9.600	0.034	0.000	QP
10		0.306	35.460	25.825	-14.619	50.078	9.600	0.034	0.000	AV
11		1.362	29.062	19.382	-26.938	56.000	9.610	0.070	0.000	QP
12		1.362	22.293	12.613	-23.707	46.000	9.610	0.070	0.000	AV

Note:

1. All Readings below 1GHz are Quasi-Peak, above are performed with peak and/or average measurements as necessary.
2. " * ", means this data is the worst emission level.
3. Measurement Level = Reading Level + Factor(Probe+Cable-Amp).

Engineer: Nino	
Site: TR1	Time: 2017/09/08 - 10:25
Limit: FCC_Part15.107_CE_AC Power_ClassB	Margin: 0
Probe: ENV216_101190(0.009-30MHz)	Polarity: Neutral
EUT: LED Lamp	Power: AC 120V/60Hz
Note: Mode 1:Transmit at2405MHz by zigbee	

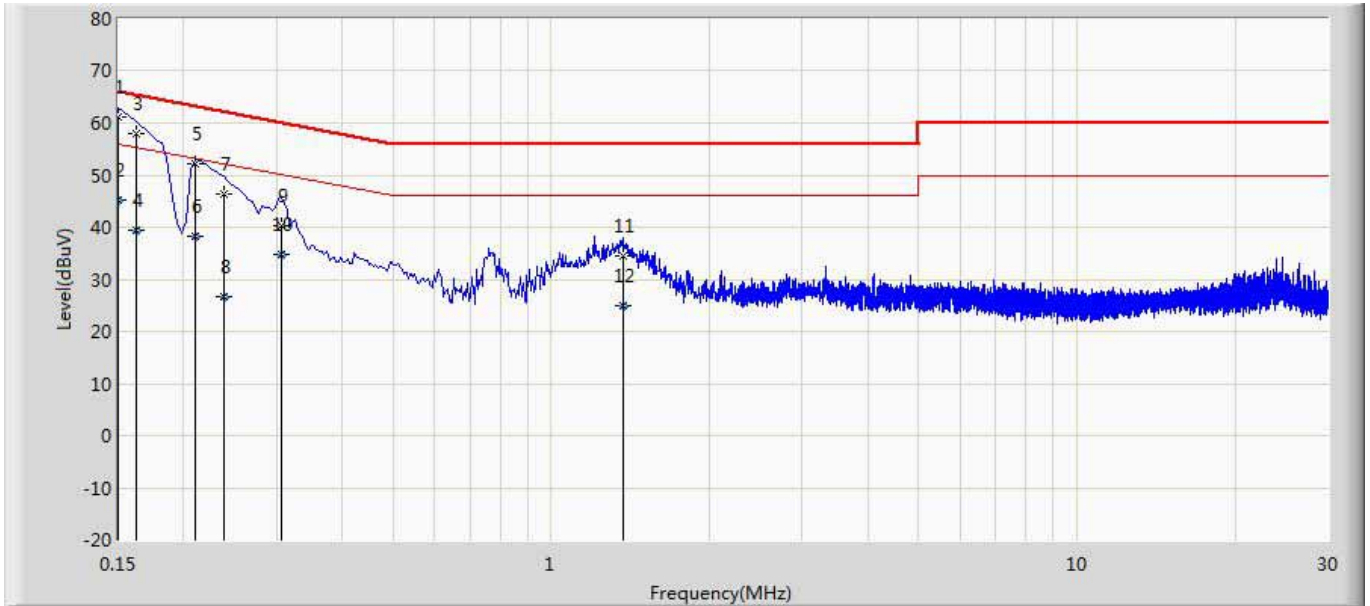

No	Mark	Frequency (MHz)	Measure Level (dBuV)	Reading Level (dBuV)	Over Limit (dB)	Limit (dBuV)	Probe (dB)	Cable (dB)	Amp (dB)	Type
1	*	0.150	61.204	51.585	-4.796	66.000	9.594	0.025	0.000	QP
2		0.150	45.182	35.563	-10.818	56.000	9.594	0.025	0.000	AV
3		0.162	58.083	48.464	-7.278	65.361	9.593	0.026	0.000	QP
4		0.162	39.481	29.863	-15.879	55.361	9.593	0.026	0.000	AV
5		0.210	52.213	42.585	-10.992	63.205	9.599	0.029	0.000	QP
6		0.210	38.378	28.751	-14.827	53.205	9.599	0.029	0.000	AV
7		0.238	46.301	36.672	-15.865	62.166	9.598	0.030	0.000	QP
8		0.238	26.702	17.073	-25.464	52.166	9.598	0.030	0.000	AV
9		0.306	40.359	30.728	-19.720	60.078	9.596	0.034	0.000	QP
10		0.306	34.703	25.072	-15.376	50.078	9.596	0.034	0.000	AV
11		1.370	34.585	24.918	-21.415	56.000	9.597	0.070	0.000	QP
12		1.370	24.809	15.141	-21.191	46.000	9.597	0.070	0.000	AV

Note:

1. All Readings below 1GHz are Quasi-Peak, above are performed with peak and/or average measurements as necessary.
2. " * ", means this data is the worst emission level.
3. Measurement Level = Reading Level + Factor(Probe+Cable-Amp).

The result for LTN+Alvis+Diodes:

Engineer: Nino	
Site: TR1	Time: 2017/09/08 - 10:36
Limit: FCC_Part15.107_CE_AC Power_ClassB	Margin: 0
Probe: ENV216_101190(0.009-30MHz)	Polarity: Line
EUT: LED Lamp	Power: AC 120V/60Hz
Note: Mode 1:Transmit at2405MHz by zigbee	

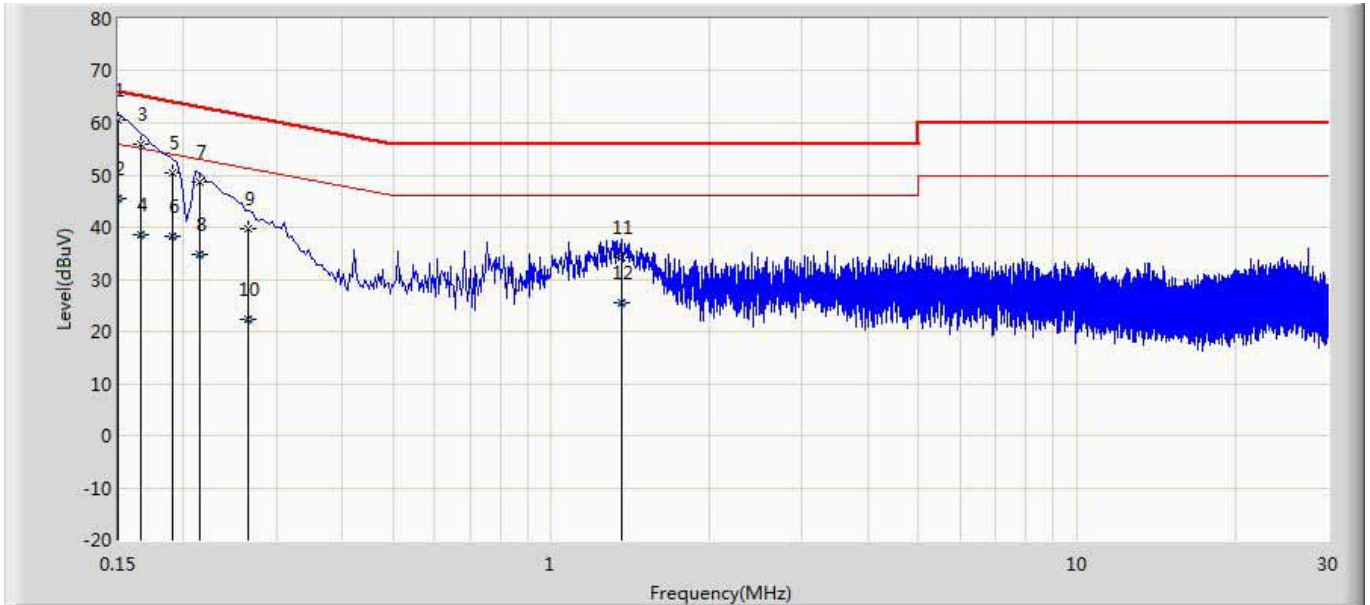

No	Mark	Frequency (MHz)	Measure Level (dBuV)	Reading Level (dBuV)	Over Limit (dB)	Limit (dBuV)	Probe (dB)	Cable (dB)	Amp (dB)	Type
1	*	0.150	60.692	51.057	-5.308	66.000	9.610	0.025	0.000	QP
2		0.150	45.539	35.904	-10.461	56.000	9.610	0.025	0.000	AV
3		0.166	56.078	46.445	-9.080	65.158	9.607	0.027	0.000	QP
4		0.166	38.672	29.039	-16.486	55.158	9.607	0.027	0.000	AV
5		0.190	50.552	40.922	-13.485	64.037	9.602	0.028	0.000	QP
6		0.190	38.156	28.526	-15.881	54.037	9.602	0.028	0.000	AV
7		0.214	48.817	39.187	-14.232	63.049	9.600	0.029	0.000	QP
8		0.214	34.640	25.010	-18.409	53.049	9.600	0.029	0.000	AV
9		0.266	39.573	29.941	-21.669	61.242	9.600	0.033	0.000	QP
10		0.266	22.292	12.660	-28.950	51.242	9.600	0.033	0.000	AV
11		1.358	34.346	24.666	-21.654	56.000	9.610	0.070	0.000	QP
12		1.358	25.614	15.934	-20.386	46.000	9.610	0.070	0.000	AV

Note:

1. All Readings below 1GHz are Quasi-Peak, above are performed with peak and/or average measurements as necessary.
2. " * ", means this data is the worst emission level.
3. Measurement Level = Reading Level + Factor(Probe+Cable-Amp).

Engineer: Nino	
Site: TR1	Time: 2017/09/08 - 10:39
Limit: FCC_Part15.107_CE_AC Power_ClassB	Margin: 0
Probe: ENV216_101190(0.009-30MHz)	Polarity: Neutral
EUT: LED Lamp	Power: AC 120V/60Hz
Note: Mode 1:Transmit at2405MHz by zigbee	

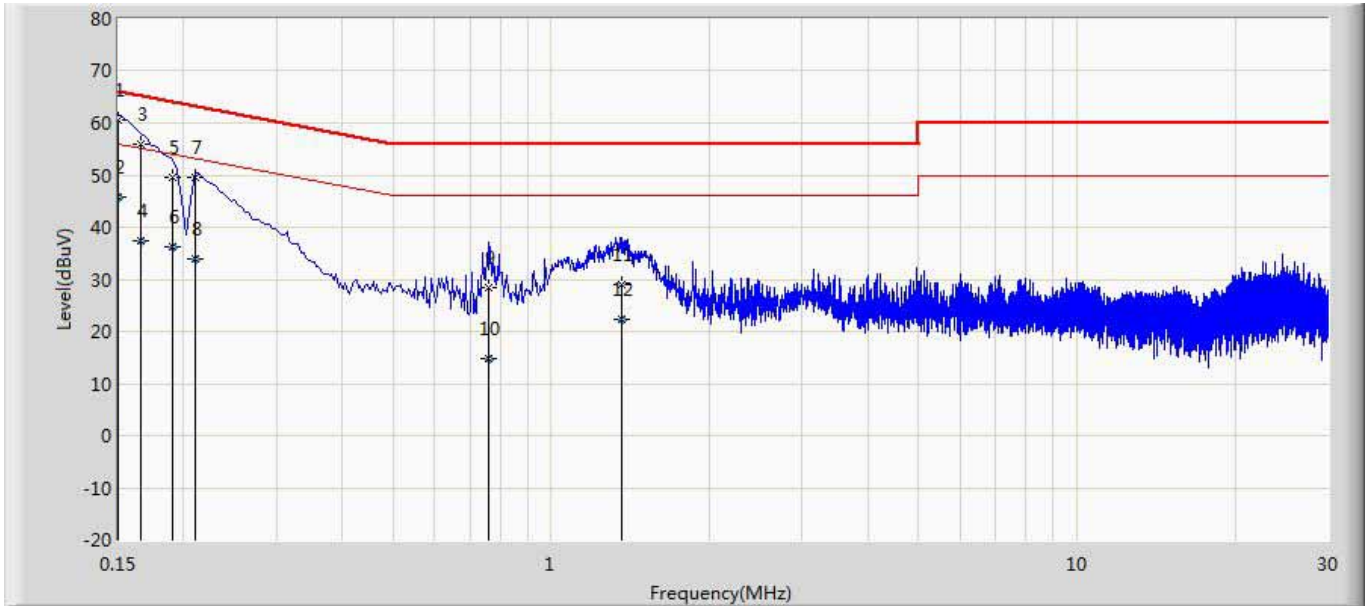

No	Mark	Frequency (MHz)	Measure Level (dBuV)	Reading Level (dBuV)	Over Limit (dB)	Limit (dBuV)	Probe (dB)	Cable (dB)	Amp (dB)	Type
1	*	0.150	60.550	50.931	-5.450	66.000	9.594	0.025	0.000	QP
2		0.150	45.685	36.067	-10.315	56.000	9.594	0.025	0.000	AV
3		0.166	55.958	46.338	-9.200	65.158	9.593	0.027	0.000	QP
4		0.166	37.460	27.840	-17.698	55.158	9.593	0.027	0.000	AV
5		0.190	49.553	39.927	-14.483	64.037	9.598	0.028	0.000	QP
6		0.190	36.303	26.677	-17.734	54.037	9.598	0.028	0.000	AV
7		0.210	49.616	39.988	-13.590	63.205	9.599	0.029	0.000	QP
8		0.210	33.873	24.245	-19.333	53.205	9.599	0.029	0.000	AV
9		0.762	28.507	18.865	-27.493	56.000	9.590	0.052	0.000	QP
10		0.762	14.766	5.124	-31.234	46.000	9.590	0.052	0.000	AV
11		1.362	28.888	19.221	-27.112	56.000	9.597	0.070	0.000	QP
12		1.362	22.389	12.722	-23.611	46.000	9.597	0.070	0.000	AV

Note:

1. All Readings below 1GHz are Quasi-Peak, above are performed with peak and/or average measurements as necessary.
2. " * ", means this data is the worst emission level.
3. Measurement Level = Reading Level + Factor(Probe+Cable-Amp).

The result for APT+Alvis+Murata:

Engineer: Nino	
Site: TR1	Time: 2017/10/11
Limit: FCC_Part15.107_CE_AC Power_ClassB	Margin: 0
Probe: ENV216_101190(0.009-30MHz)	Polarity: Line
EUT: LED Lamp	Power: AC 120V/60Hz

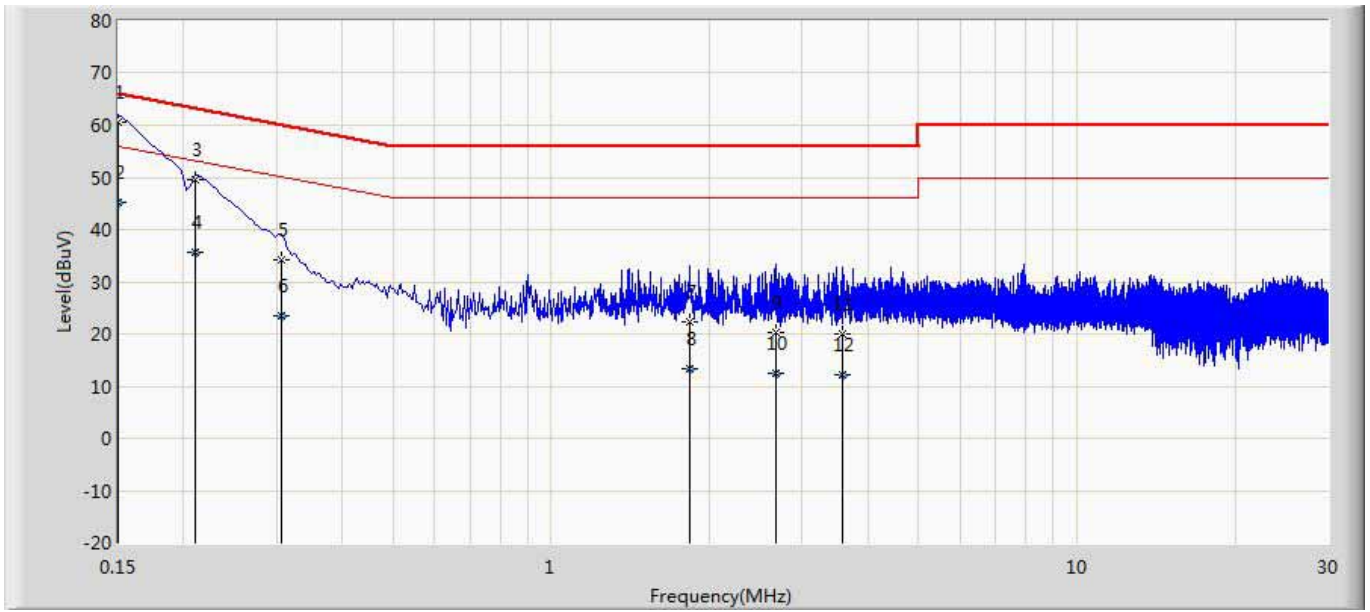

No	Mark	Frequency (MHz)	Measure Level (dBuV)	Reading Level (dBuV)	Over Limit (dB)	Limit (dBuV)	Probe (dB)	Cable (dB)	Amp (dB)	Type
1	*	0.150	60.657	51.039	-5.343	66.000	9.594	0.025	0.000	QP
2		0.150	45.167	35.548	-10.833	56.000	9.594	0.025	0.000	AV
3		0.210	49.449	39.821	-13.757	63.205	9.599	0.029	0.000	QP
4		0.210	35.564	25.937	-17.641	53.205	9.599	0.029	0.000	AV
5		0.306	34.334	24.704	-25.744	60.078	9.596	0.034	0.000	QP
6		0.306	23.414	13.783	-26.665	50.078	9.596	0.034	0.000	AV
7		1.830	22.194	12.504	-33.806	56.000	9.607	0.083	0.000	QP
8		1.830	13.317	3.628	-32.683	46.000	9.607	0.083	0.000	AV
9		2.682	20.168	10.447	-35.832	56.000	9.619	0.102	0.000	QP
10		2.682	12.478	2.757	-33.522	46.000	9.619	0.102	0.000	AV
11		3.574	20.117	10.365	-35.883	56.000	9.631	0.120	0.000	QP
12		3.574	12.245	2.494	-33.755	46.000	9.631	0.120	0.000	AV

Note:

1. " * ", means this data is the worst emission level.
2. Measurement Level = Reading Level + Factor(Probe+Cable-Amp).

Engineer: Nino	
Site: TR1	Time: 2017/10/11
Limit: FCC_Part15.107_CE_AC Power_ClassB	Margin: 0
Probe: ENV216_101190(0.009-30MHz)	Polarity: Neutral
EUT: LED Lamp	Power: AC 120V/60Hz

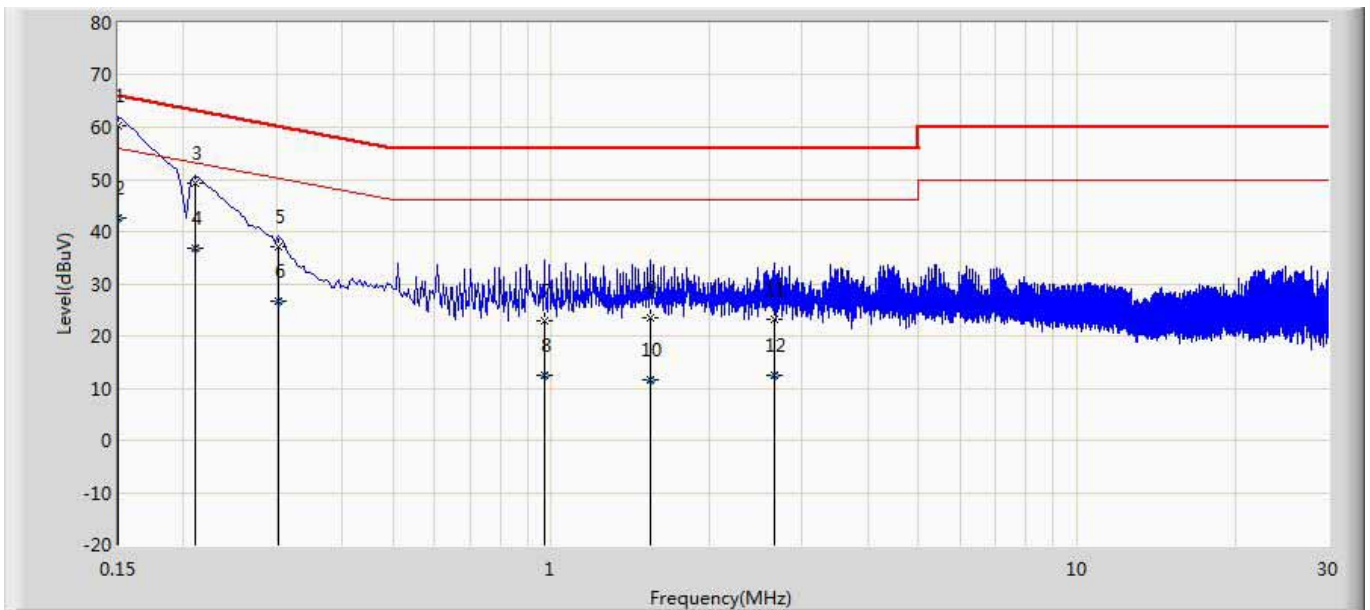

No	Mark	Frequency (MHz)	Measure Level (dBuV)	Reading Level (dBuV)	Over Limit (dB)	Limit (dBuV)	Probe (dB)	Cable (dB)	Amp (dB)	Type
1	*	0.150	60.358	50.739	-5.642	66.000	9.594	0.025	0.000	QP
2		0.150	42.640	33.021	-13.360	56.000	9.594	0.025	0.000	AV
3		0.210	49.355	39.727	-13.850	63.205	9.599	0.029	0.000	QP
4		0.210	36.898	27.271	-16.307	53.205	9.599	0.029	0.000	AV
5		0.302	37.086	27.456	-23.101	60.188	9.596	0.034	0.000	QP
6		0.302	26.622	16.991	-23.566	50.188	9.596	0.034	0.000	AV
7		0.970	22.893	13.244	-33.107	56.000	9.590	0.059	0.000	QP
8		0.970	12.330	2.681	-33.670	46.000	9.590	0.059	0.000	AV
9		1.542	23.460	13.784	-32.540	56.000	9.601	0.075	0.000	QP
10		1.542	11.514	1.838	-34.486	46.000	9.601	0.075	0.000	AV
11		2.662	23.106	13.385	-32.894	56.000	9.619	0.102	0.000	QP
12		2.662	12.407	2.686	-33.593	46.000	9.619	0.102	0.000	AV

Note:

1. " * ", means this data is the worst emission level.
2. Measurement Level = Reading Level + Factor(Probe+Cable-Amp).

4. Emissions in restricted frequency bands

4.1. Test Equipment

Radiated Emission(Below 1GHz) / AC-2					
Instrument	Manufacturer	Type No.	Serial No.	Cal. Date	Cal. Due Date
EMI Test Receiver	R&S	ESCI	100573	2017.03.29	2018.03.28
Loop Antenna	R&S	HFH2-Z2	833799/003	2016.11.16	2017.11.15
Bilog Antenna	Teseq GmbH	CBL6112D	27611	2016.10.16	2018.10.15
Coaxial Cable	Huber+Suhner	SUCOFLEX 106	AC2-C	2016.03.02	2018.03.01
Temperature/Humidity Meter	Zhichen	ZC1-2	AC2-TH	2017.01.03	2018.01.02

Note: All equipment are calibrated with traceable calibrations. Each calibration is traceable to the national or international standards.

Radiated Emission(Above 1GHz) / AC-5					
Instrument	Manufacturer	Type No.	Serial No.	Cal. Date	Cal. Due Date
Spectrum Analyzer	Agilent	E4446A	MY45300103	2017.01.04	2018.01.03
Preamplifier	Miteq	NSP1800-25	1364185	2017.05.06	2018.05.05
Preamplifier	QuieTek	AP-040G	CHM-0906001	2017.05.06	2018.05.05
DRG Horn	ETS-Lindgren	3117	00123988	2017.01.22	2018.01.21
Broad-Band Horn Antenna	Schwarzbeck	BBHA9170	294	2016.11.25	2017.11.24
Coaxial Cable	Huber+Suhner	SUCOFLEX 106	AC5-C1	2016.03.02	2018.03.01
Coaxial Cable	Huber+Suhner	SUCOFLEX 106	AC5-C2	2016.03.02	2018.03.01
Coaxial Cable	Huber+Suhner	SUCOFLEX 102	AC5-C3	2016.03.02	2018.03.01
EMI Receiver	Agilent	N9038A	MY51210196	2017.06.10	2018.06.09
Temperature/Humidity Meter	Zhichen	ZC1-2	AC5-TH	2017.01.04	2018.01.03

Note: All equipment are calibrated with traceable calibrations. Each calibration is traceable to the national or international standards.

4.2. Test Setup

Below 30MHz Test Setup:

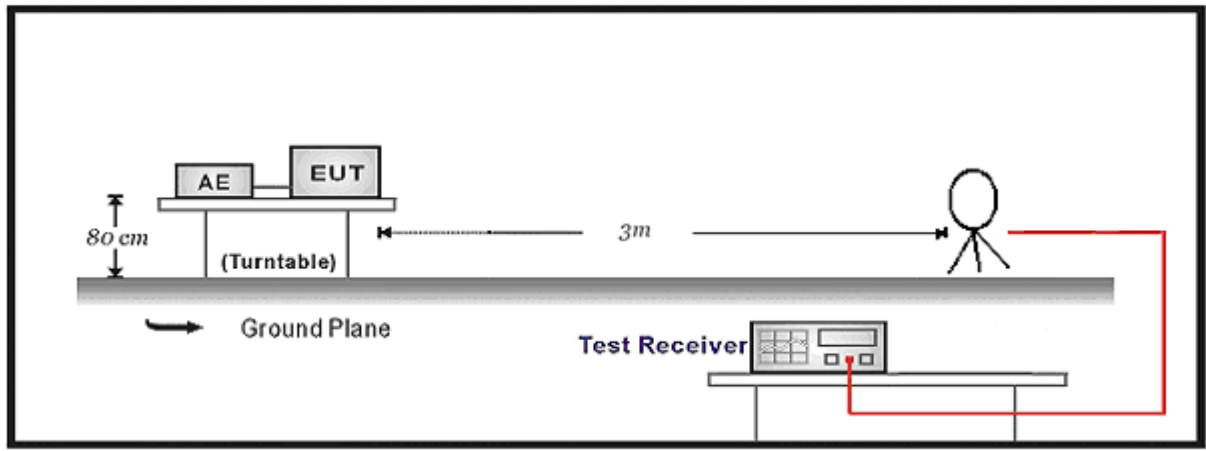

30MHz-1GHz Test Setup:

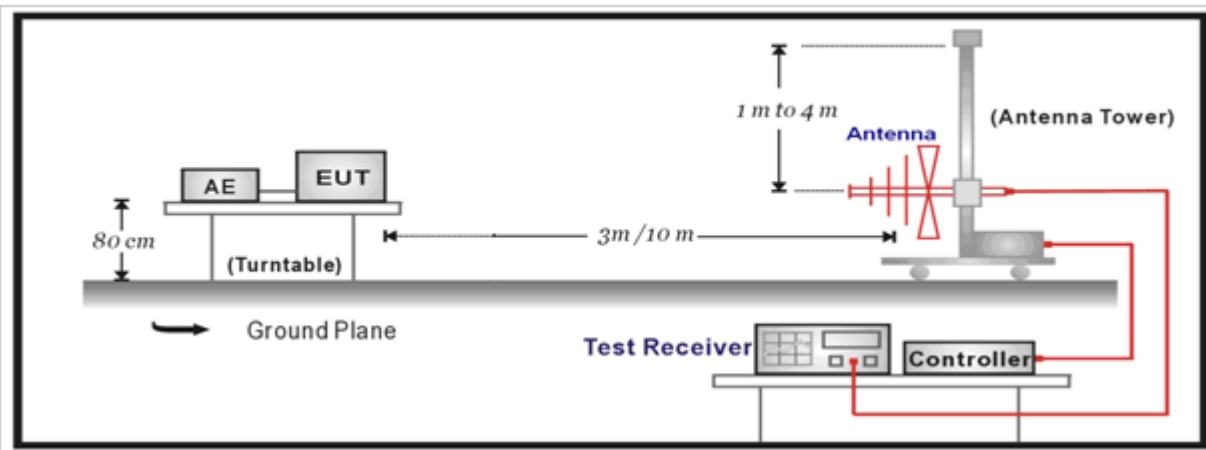

Above 1GHz Test Setup:

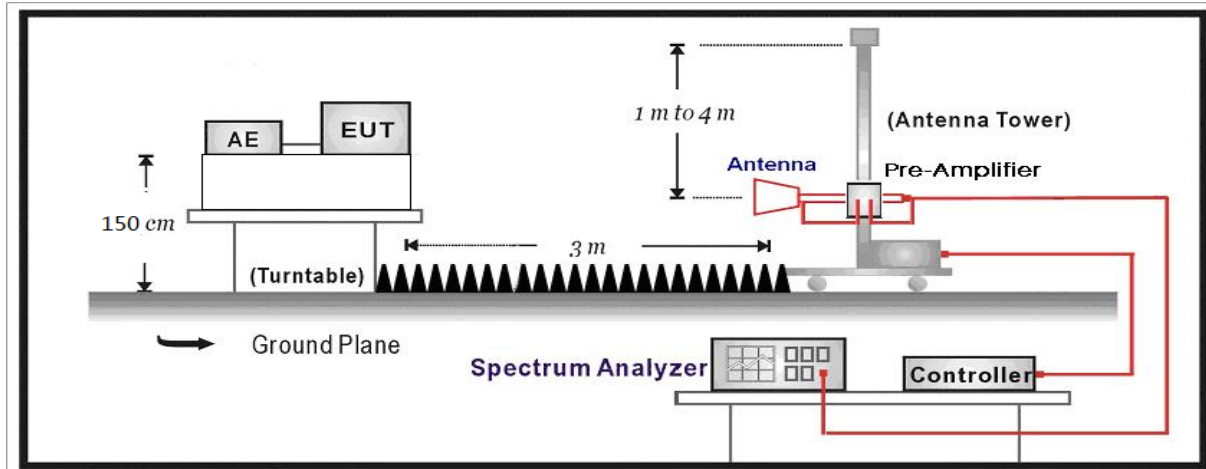

4.3. Limit

For FCC

Restricted Bands of operation			
Frequency (MHz)	Frequency (MHz)	Frequency (MHz)	Frequency (GHz)
0.090 – 0.110	16.42 – 16.423	399.9 – 410	4.5 – 5.15
0.495 – 0.505	16.69475 – 16.69525	608 – 614	5.35 – 5.46
2.1735 – 2.1905	16.80425 – 16.80475	960 – 1240	7.25 – 7.75
4.125 – 4.128	25.5 – 25.67	1300 – 1427	8.025 – 8.5
4.17725 – 4.17775	37.5 – 38.25	1435 – 1626.5	9.0 – 9.2
4.20725 – 4.20775	73 – 74.6	1645.5 – 1646.5	9.3 – 9.5
6.215 – 6.218	74.8 – 75.2	1660 – 1710	10.6 – 12.7
6.26775 – 6.26825	108 – 121.94	1718.8 – 1722.2	13.25 – 13.4
6.31175 – 6.31225	123 – 138	2200 – 2300	14.47 – 14.5
8.291 – 8.294	149.9 – 150.05	2310 – 2390	15.35 – 16.2
8.362 – 8.366	156.52475 – 156.52525	2483.5 – 2500	17.7 – 21.4
8.37625 – 8.38675	156.7 – 156.9	2690 – 2900	22.01 – 23.12
8.81425 – 8.81475	162.0125 – 167.17	3260 – 3267	23.6 – 24.0
12.29 – 12.293	167.72 – 173.2	3332 – 3339	31.2 – 31.8
12.51975 – 12.52025	240 – 285	3345.8 – 3358	36.43 – 36.5
12.57675 – 12.57725	322 – 335.4	3600 – 4400	
13.36 – 13.41			

For IC:

Restricted Bands of operation			
Frequency (MHz)	Frequency (MHz)	Frequency (MHz)	Frequency (GHz)
0.090-0.110	13.36-13.41	1645.5-1646.5	9.0-9.2
2.1735-2.1905	16.42-16.423	1660-1710	9.3-9.5
3.020-3.026	16.69475-16.69525	1718.8-1722.2	10.6-12.7
4.125-4.128	16.80425-16.80475	2200-2300	13.25-13.4
4.17725-4.17775	25.5-25.67	2310-2390	14.47-14.5
4.20725-4.20775	37.5-38.25	2655-2900	15.35-16.2
5.677-5.683	73-74.6	3260-3267	17.7-21.4
6.215-6.218	74.8-75.2	3332-3339	22.01-23.12
6.26775-6.26825	108-138	3345.8-3358	23.6-24.0
6.31175-6.31225	156.52475-156.52525	3500-4400	31.2-31.8
8.291-8.294	156.7-156.9	4500-5150	36.43-36.5
8.362-8.366	240-285	5350-5460	Above 38.6
8.37625-8.38675	322-335.4	7250-7750	
8.41425-8.41475	399.9-410	8025-8500	
12.29-12.293	608-614		
12.51975-12.52025	960-1427		
12.57675-12.57725	1435-1626.5		

Restricted Band Emissions Limit			
Frequency (MHz)	Field strength (μ V/m)	Field strength (dB μ V/m)	Measurement distance (m)
0.009 - 0.49	2400/F(kHz)	48.5 – 13.8	300 _(Note 1)
0.49 - 1.705	24000/F(kHz)	33.8 - 23	30 _(Note 1)
1.705 - 30	30	29.5	30 _(Note 1)
30 - 88	100	40	3 _(Note 2)
88 - 216	150	43.5	3 _(Note 2)
216 - 960	200	46	3 _(Note 2)
Above 960	500	54	3 _(Note 2)





Note 1: At frequencies below 30 MHz, measurements may be performed at a distance closer than that specified in the regulations; however, an attempt should be made to avoid making measurements in the near field. Pending the development of an appropriate measurement procedure for measurements performed below 30 MHz, when performing measurements at a closer distance than specified, the results shall be extrapolated to the specified distance by either making measurements at a minimum of two distances on at least one radial to determine the proper extrapolation factor or by using the square of an inverse linear distance extrapolation factor (40 dB/decade).

Note 2: At frequencies at or above 30 MHz, measurements may be performed at a distance other than what is specified provided: measurements are not made in the near field except where it can be shown that near field measurements are appropriate due to the characteristics of the device; and it can be demonstrated that the signal levels needed to be measured at the distance employed can be detected by the measurement equipment. Measurements shall not be performed at a distance greater than 30 meters unless it can be further demonstrated that measurements at a distance of 30 meters or less are impractical. When performing measurements at a distance other than that specified, the results shall be extrapolated to the specified distance using an extrapolation factor of 20 dB/decade (inverse linear-distance for field strength measurements; inverse-linear-distance-squared for power density measurements).

4.4. Test Procedure

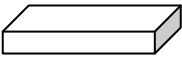
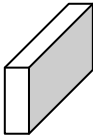
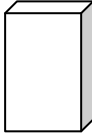
Test Method			
	References Rule	Chapter	Description
<input type="checkbox"/>	ANSI C63.10	11.11	Emissions in non-restricted frequency bands
	<input type="checkbox"/> ANSI C63.10	11.11.2	Reference level measurement
	<input type="checkbox"/> ANSI C63.10	11.11.3	Emission level measurement
<input checked="" type="checkbox"/>	ANSI C63.10	11.12	Emissions in restricted frequency bands
	<input checked="" type="checkbox"/> ANSI C63.10	11.12.1	Radiated emission measurements
	<input checked="" type="checkbox"/> ANSI C63.10	11.12.2.7	Radiated spurious emission test
	<input checked="" type="checkbox"/> ANSI C63.10	6.4	Radiated emissions from unlicensed wireless devices below 30 MHz
	<input checked="" type="checkbox"/> ANSI C63.10	6.5	Radiated emissions from unlicensed wireless devices in the frequency range of 30 MHz to 1000 MHz
	<input checked="" type="checkbox"/> ANSI C63.10	6.6	Radiated emissions from unlicensed wireless devices above 1 GHz
	<input type="checkbox"/> ANSI C63.10	11.12.2.3	Quasi-peak measurement procedure
	<input checked="" type="checkbox"/> ANSI C63.10	11.12.2.4	Peak power measurement procedure
	<input checked="" type="checkbox"/> ANSI C63.10	11.12.2.5	Average power measurement procedures
	<input type="checkbox"/> ANSI C63.10	11.12.2.5.1	Trace averaging with continuous EUT transmission at full power
	<input type="checkbox"/> ANSI C63.10	11.12.2.5.2	Trace averaging across ON and OFF times of the EUT transmissions followed by duty cycle correction
	<input checked="" type="checkbox"/> ANSI C63.10	11.12.2.5.3	Reduced VBW averaging across ON and OFF times of the EUT transmissions with max hold

4.5. EUT test Axis definition

Item	Emissions in restricted frequency bands			
Device Category	<input type="checkbox"/>	Fixed point-to-point		
	<input type="checkbox"/>	Emit multiple directional beams, simultaneously or sequentially		
	<input checked="" type="checkbox"/>	Other cases		
Test mode	Mode 1			
Test method	<input checked="" type="checkbox"/>	Radiated		
		X Axis	Y Axis	Z Axis
				
		Worst Axis <input checked="" type="checkbox"/>	Worst Axis <input type="checkbox"/>	Worst Axis <input type="checkbox"/>
	<input type="checkbox"/>	Conducted		
	<input type="checkbox"/>	Chain 0		
				
	<input type="checkbox"/>	Chain 0	Chain 1	
				
	<input type="checkbox"/>	Chain 0	Chain 1	Chain 2
				

4.6. Test Result

The result for APT+Alvis+Diodes:

Engineer: Karl	
Site: AC5	Time: 2017/10/11 - 09:46
Limit: FCC_Part15.209_RE(3m)	Margin: 0
Probe: Horn_3117_00167055(1-18GHz)	Polarity: Horizontal
EUT: LED lamp	Power: AC 120V/60Hz
Note: Mode 1:Transmit at2405MHz by zigbee	

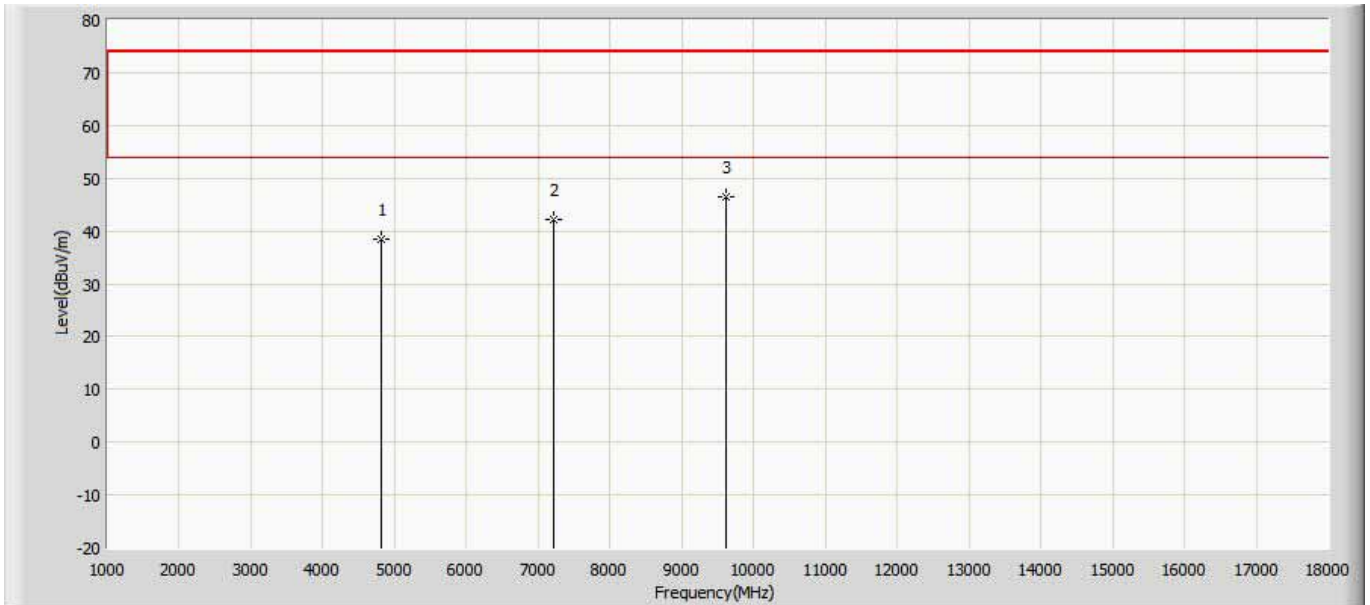

No	Mark	Frequency (MHz)	Measure Level (dBuV/m)	Reading Level (dBuV)	Over Limit (dB)	Limit (dBuV/m)	Factor (dB)	Type
1		4810.000	38.403	51.413	-35.597	74.000	-13.010	PK
2		7215.000	42.247	49.957	-31.753	74.000	-7.710	PK
3	*	9620.000	46.377	47.967	-27.623	74.000	-1.590	PK

Engineer: Karl	
Site: AC5	Time: 2017/10/11 - 09:46
Limit: FCC_Part15.209_RE(3m)	Margin: 0
Probe: Horn_3117_00167055(1-18GHz)	Polarity: Vertical
EUT: LED lamp	Power: AC 120V/60Hz
Note: Mode 1:Transmit at2405MHz by zigbee	

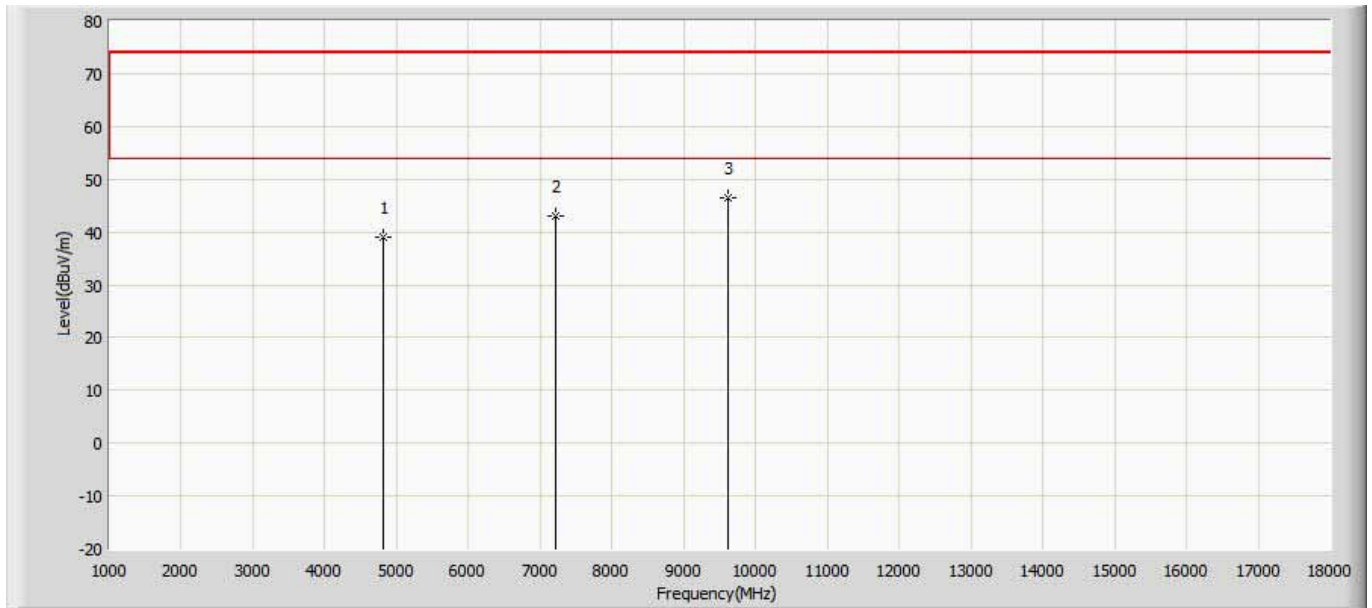

No	Mark	Frequency (MHz)	Measure Level (dBuV/m)	Reading Level (dBuV)	Over Limit (dB)	Limit (dBuV/m)	Factor (dB)	Type
1		4810.000	39.130	52.140	-34.870	74.000	-13.010	PK
2		7215.000	43.034	50.744	-30.966	74.000	-7.710	PK
3	*	9620.000	46.579	48.169	-27.421	74.000	-1.590	PK

Engineer: Karl	
Site: AC5	Time: 2017/10/11 - 09:47
Limit: FCC_Part15.209_RE(3m)	Margin: 0
Probe: Horn_3117_00167055(1-18GHz)	Polarity: Horizontal
EUT: LED lamp	Power: AC 120V/60Hz
Note: Mode 1:Transmit at2450MHz by zigbee	

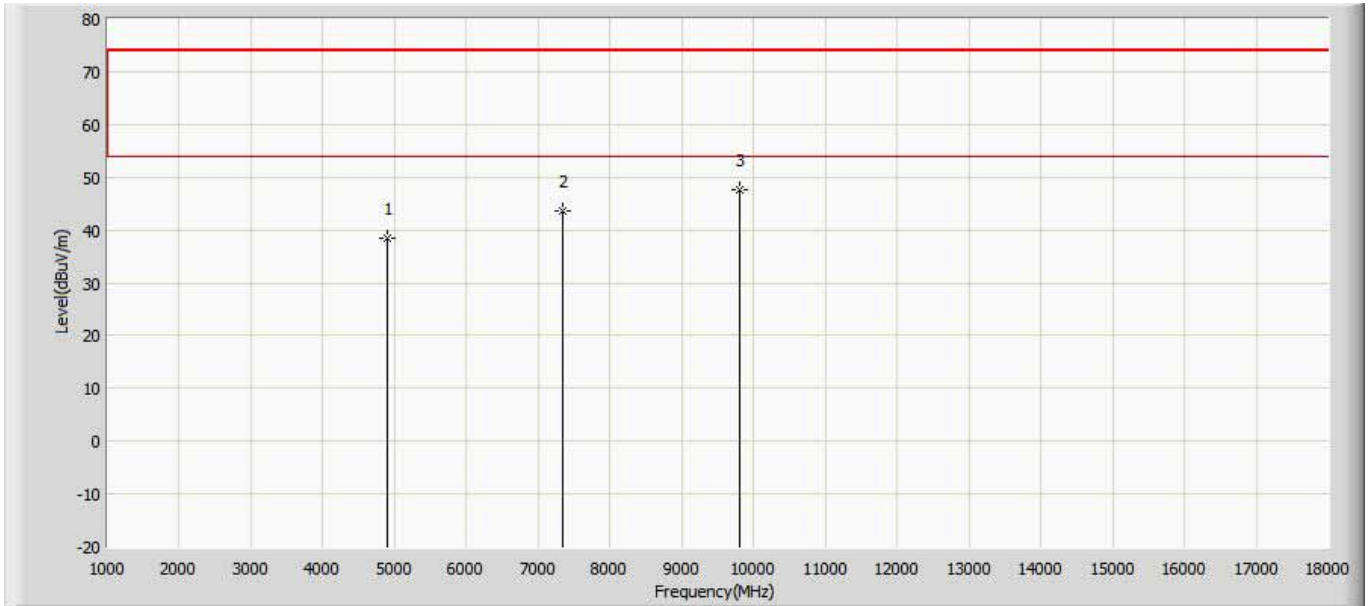

No	Mark	Frequency (MHz)	Measure Level (dBuV/m)	Reading Level (dBuV)	Over Limit (dB)	Limit (dBuV/m)	Factor (dB)	Type
1		4900.000	38.366	51.376	-35.634	74.000	-13.010	PK
2		7350.000	43.536	51.246	-30.464	74.000	-7.710	PK
3	*	9800.000	47.739	49.329	-26.261	74.000	-1.590	PK

Engineer: Karl	
Site: AC5	Time: 2017/10/11 - 09:47
Limit: FCC_Part15.209_RE(3m)	Margin: 0
Probe: Horn_3117_00167055(1-18GHz)	Polarity: Vertical
EUT: LED lamp	Power: AC 120V/60Hz
Note: Mode 1:Transmit at2450MHz by zigbee	

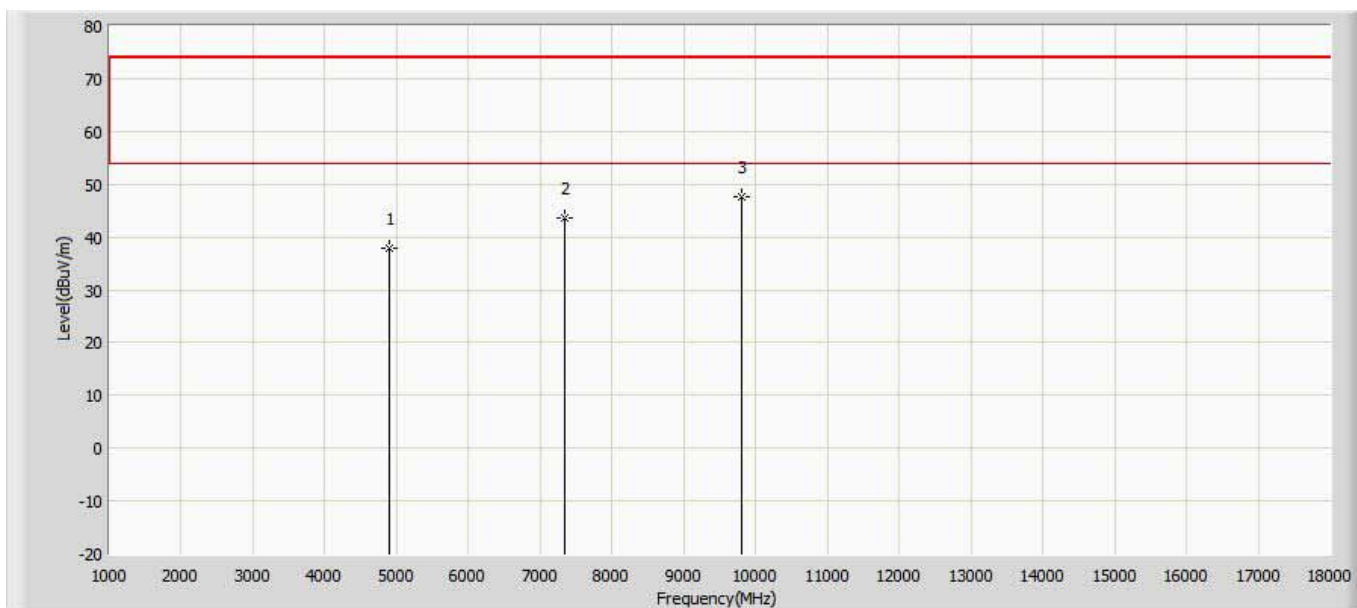

No	Mark	Frequency (MHz)	Measure Level (dBuV/m)	Reading Level (dBuV)	Over Limit (dB)	Limit (dBuV/m)	Factor (dB)	Type
1		4900.000	37.748	50.758	-36.252	74.000	-13.010	PK
2		7350.000	43.602	51.312	-30.398	74.000	-7.710	PK
3	*	9800.000	47.737	49.327	-26.263	74.000	-1.590	PK

Engineer: Karl	
Site: AC5	Time: 2017/10/11 - 09:47
Limit: FCC_Part15.209_RE(3m)	Margin: 0
Probe: Horn_3117_00167055(1-18GHz)	Polarity: Horizontal
EUT: LED lamp	Power: AC 120V/60Hz
Note: Mode 1:Transmit at2480MHz by zigbee	

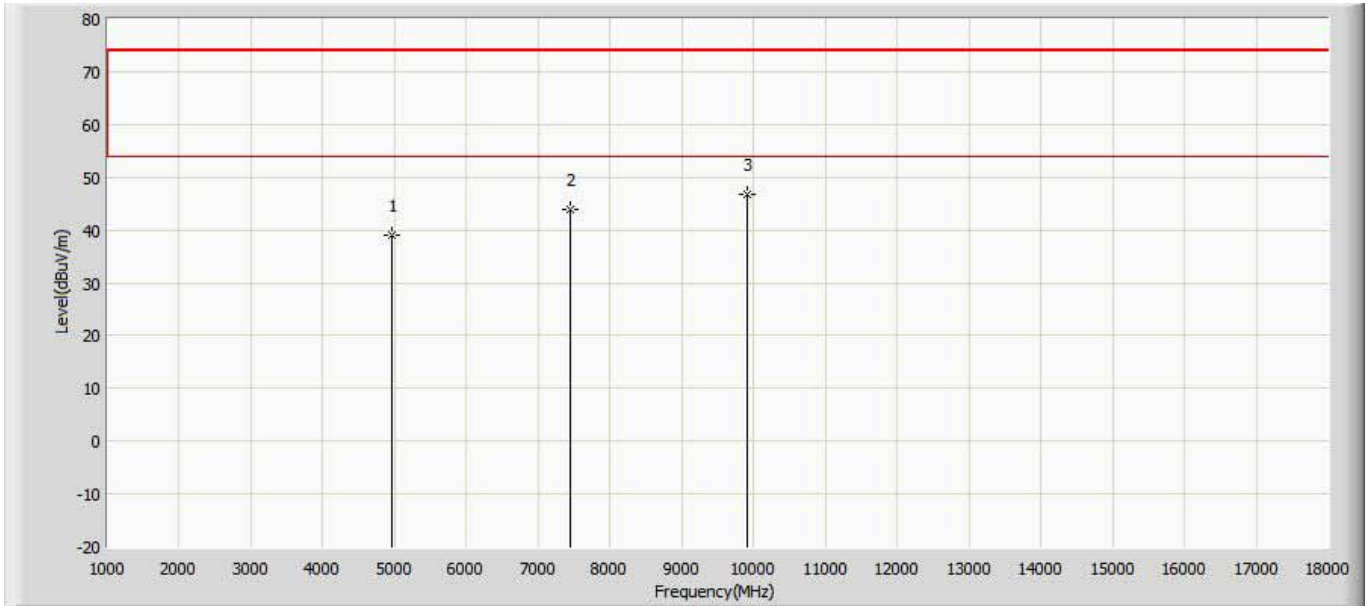

No	Mark	Frequency (MHz)	Measure Level (dBuV/m)	Reading Level (dBuV)	Over Limit (dB)	Limit (dBuV/m)	Factor (dB)	Type
1		4960.000	39.032	51.262	-34.968	74.000	-12.230	PK
2		7440.000	43.904	50.564	-30.096	74.000	-6.660	PK
3	*	9920.000	46.865	48.825	-27.135	74.000	-1.960	PK

Engineer: Karl	
Site: AC5	Time: 2017/10/11 - 09:48
Limit: FCC_Part15.209_RE(3m)	Margin: 0
Probe: Horn_3117_00167055(1-18GHz)	Polarity: Vertical
EUT: LED lamp	Power: AC 120V/60Hz
Note: Mode 1:Transmit at2480MHz by zigbee	

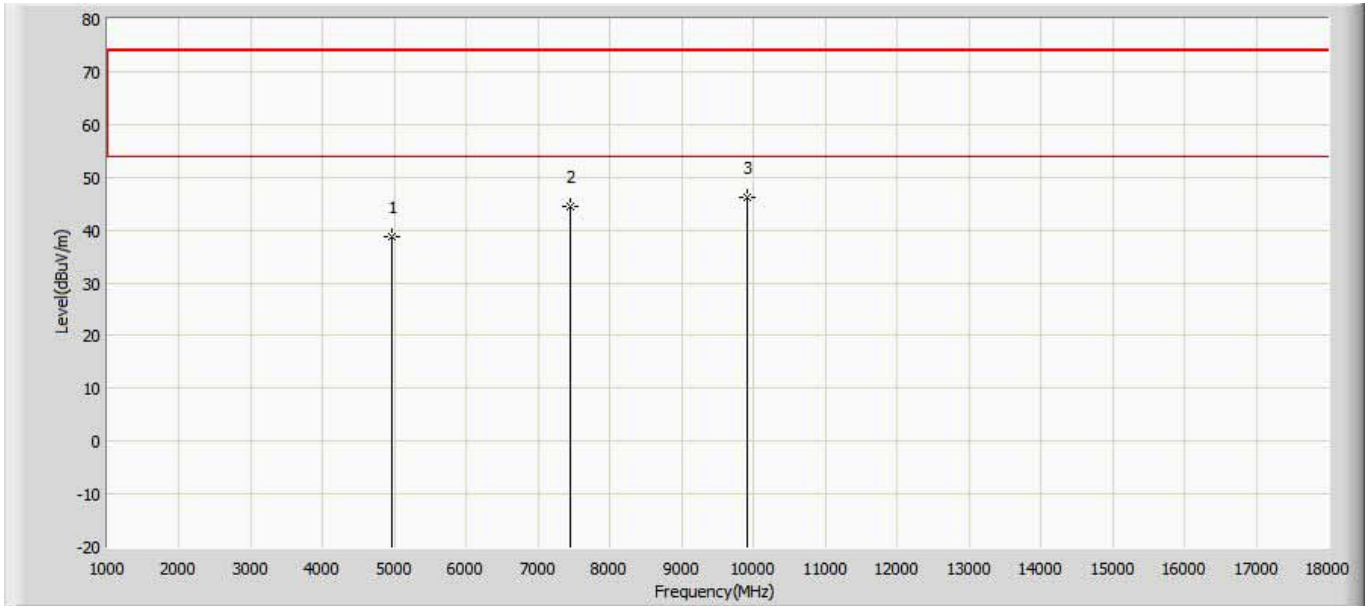

No	Mark	Frequency (MHz)	Measure Level (dBuV/m)	Reading Level (dBuV)	Over Limit (dB)	Limit (dBuV/m)	Factor (dB)	Type
1		4960.000	38.872	51.102	-35.128	74.000	-12.230	PK
2		7440.000	44.401	51.061	-29.599	74.000	-6.660	PK
3	*	9920.000	46.285	48.245	-27.715	74.000	-1.960	PK

Note:

1. Measured Level = Reading Level + Factor.
2. The test frequency range, 9kHz~30MHz, 18GHz~26GHz, both of the worst case are at least 20dB below the limits, therefore no data appear in the report.
3. This limit applies for using average detector, if the test result on peak is lower than average limit, then average measurement needn't be performed.
4. As the radiated emission was performed, so conducted emission was not tested.

The result for LTN+Alvis+Diodes:

Engineer: allen	
Site: AC5	Time: 2017/10/18 - 20:11
Limit: FCC_Part15.209_RE(3m)	Margin: 0
Probe: Horn_3117_00167055(1-18GHz)	Polarity: Horizontal
EUT: LED lamp	Power: AC 120V/60Hz
Note: Mode 1:Transmit at 2405MHz by zigbee	

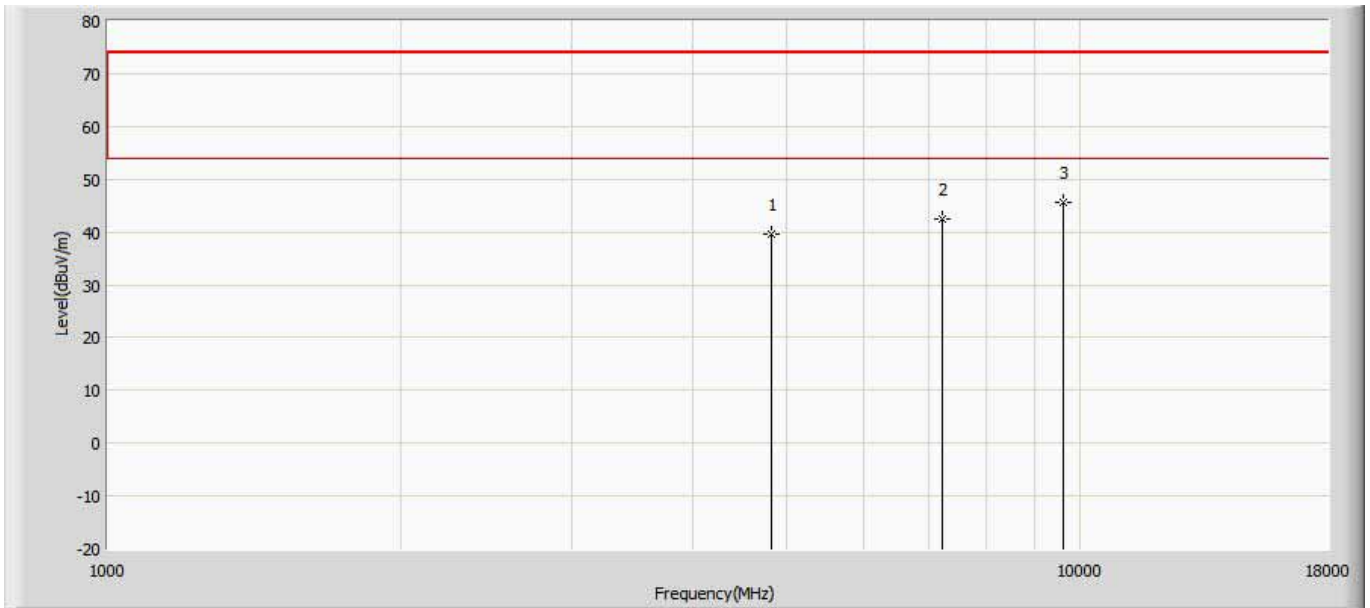

No	Mark	Frequency (MHz)	Measure Level (dBuV/m)	Reading Level (dBuV)	Over Limit (dB)	Limit (dBuV/m)	Factor (dB)	Type
1		4810.000	39.553	52.563	-34.447	74.000	-13.010	PK
2		7215.000	42.405	50.115	-31.595	74.000	-7.710	PK
3	*	9620.000	45.509	47.099	-28.491	74.000	-1.590	PK

Engineer: allen	
Site: AC5	Time: 2017/10/18 - 20:11
Limit: FCC_Part15.209_RE(3m)	Margin: 0
Probe: Horn_3117_00167055(1-18GHz)	Polarity: Vertical
EUT: LED lamp	Power: AC 120V/60Hz
Note: Mode 1:Transmit at 2405MHz by zigbee	

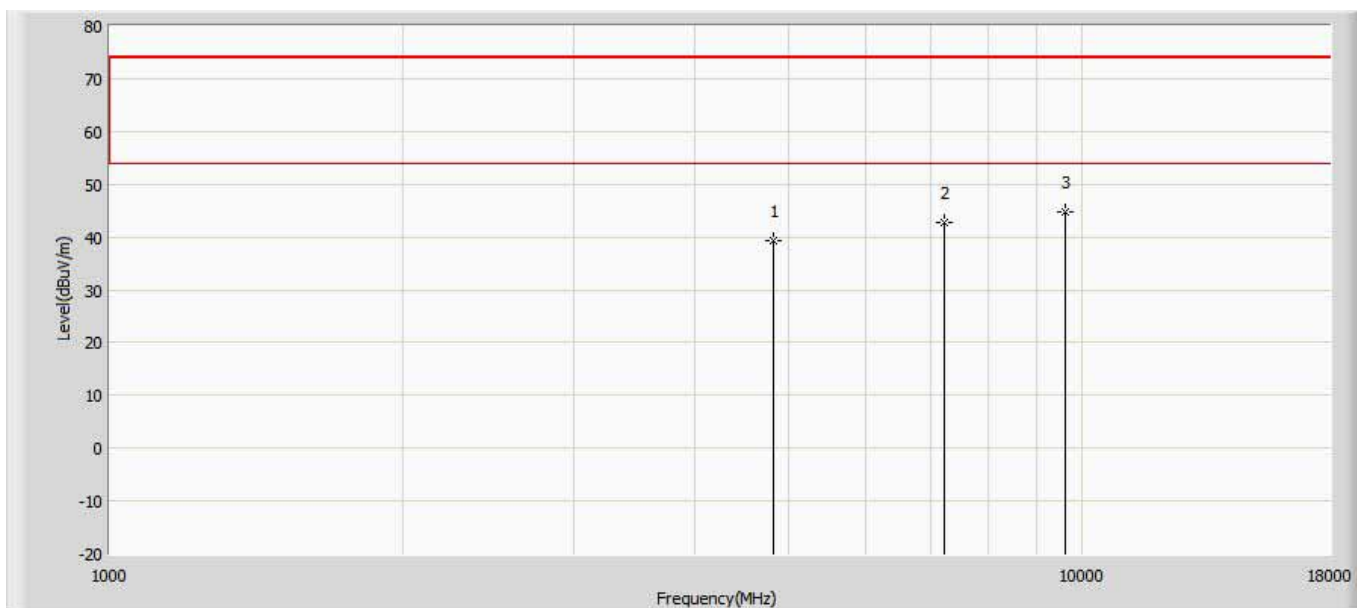

No	Mark	Frequency (MHz)	Measure Level (dBuV/m)	Reading Level (dBuV)	Over Limit (dB)	Limit (dBuV/m)	Factor (dB)	Type
1		4810.000	39.376	52.386	-34.624	74.000	-13.010	PK
2		7215.000	42.689	50.399	-31.311	74.000	-7.710	PK
3	*	9620.000	44.635	46.225	-29.365	74.000	-1.590	PK

Engineer: allen	
Site: AC5	Time: 2017/10/18 - 20:12
Limit: FCC_Part15.209_RE(3m)	Margin: 0
Probe: Horn_3117_00167055(1-18GHz)	Polarity: Horizontal
EUT: LED lamp	Power: AC 120V/60Hz
Note: Mode 1:Transmit at 2450MHz by zigbee	

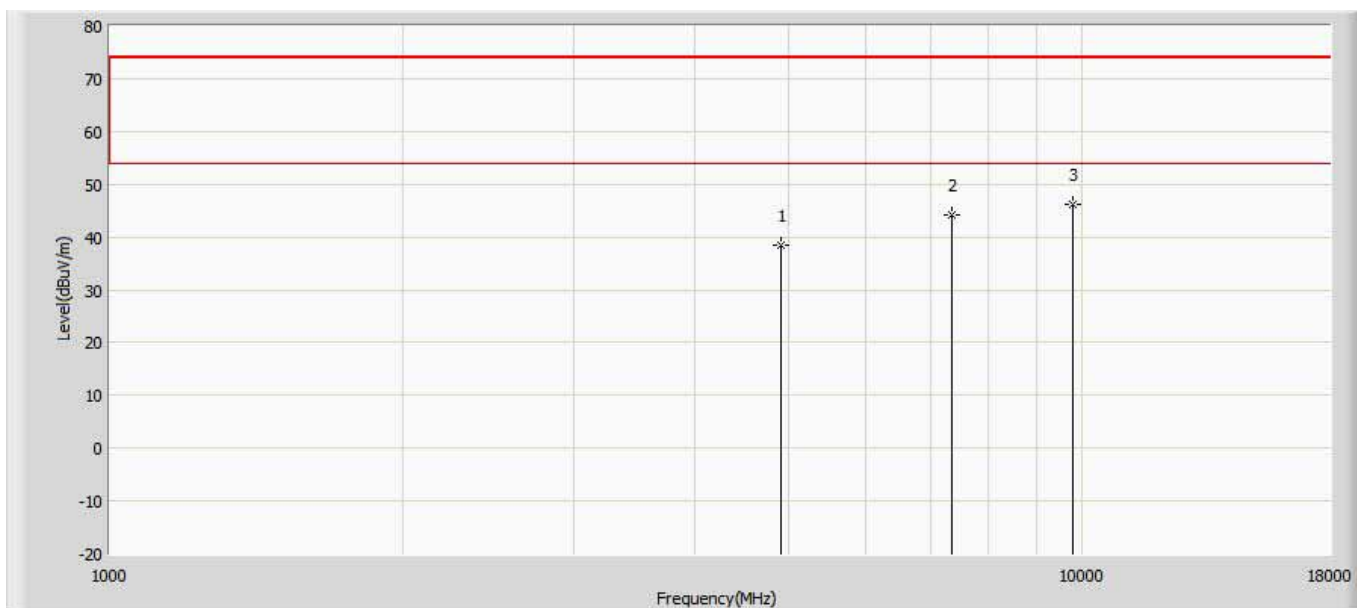

No	Mark	Frequency (MHz)	Measure Level (dBuV/m)	Reading Level (dBuV)	Over Limit (dB)	Limit (dBuV/m)	Factor (dB)	Type
1		4900.000	38.345	51.355	-35.655	74.000	-13.010	PK
2		7350.000	44.068	51.778	-29.932	74.000	-7.710	PK
3	*	9800.000	46.282	47.872	-27.718	74.000	-1.590	PK

Engineer: allen	
Site: AC5	Time: 2017/10/18 - 20:12
Limit: FCC_Part15.209_RE(3m)	Margin: 0
Probe: Horn_3117_00167055(1-18GHz)	Polarity: Vertical
EUT: LED lamp	Power: AC 120V/60Hz
Note: Mode 1:Transmit at 2450MHz by zigbee	

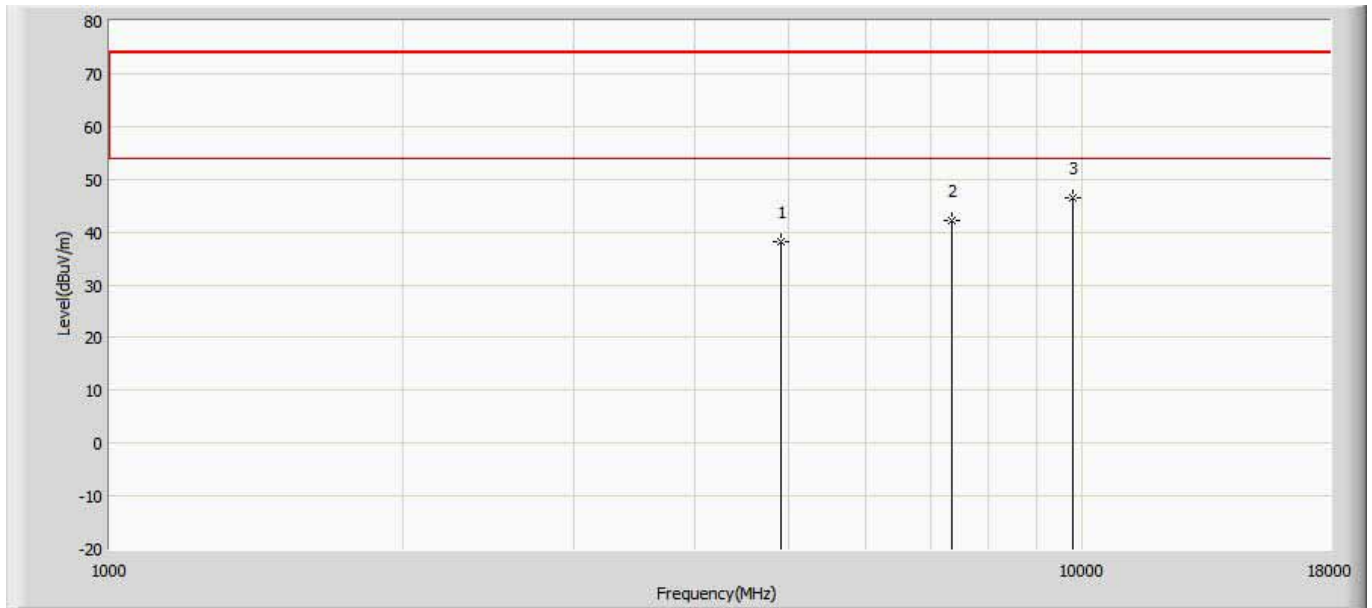

No	Mark	Frequency (MHz)	Measure Level (dBuV/m)	Reading Level (dBuV)	Over Limit (dB)	Limit (dBuV/m)	Factor (dB)	Type
1		4900.000	38.114	51.124	-35.886	74.000	-13.010	PK
2		7350.000	42.237	49.947	-31.763	74.000	-7.710	PK
3	*	9800.000	46.431	48.021	-27.569	74.000	-1.590	PK

Engineer: allen	
Site: AC5	Time: 2017/10/18 - 20:12
Limit: FCC_Part15.209_RE(3m)	Margin: 0
Probe: Horn_3117_00167055(1-18GHz)	Polarity: Horizontal
EUT: LED lamp	Power: AC 120V/60Hz
Note: Mode 1:Transmit at 2480MHz by zigbee	

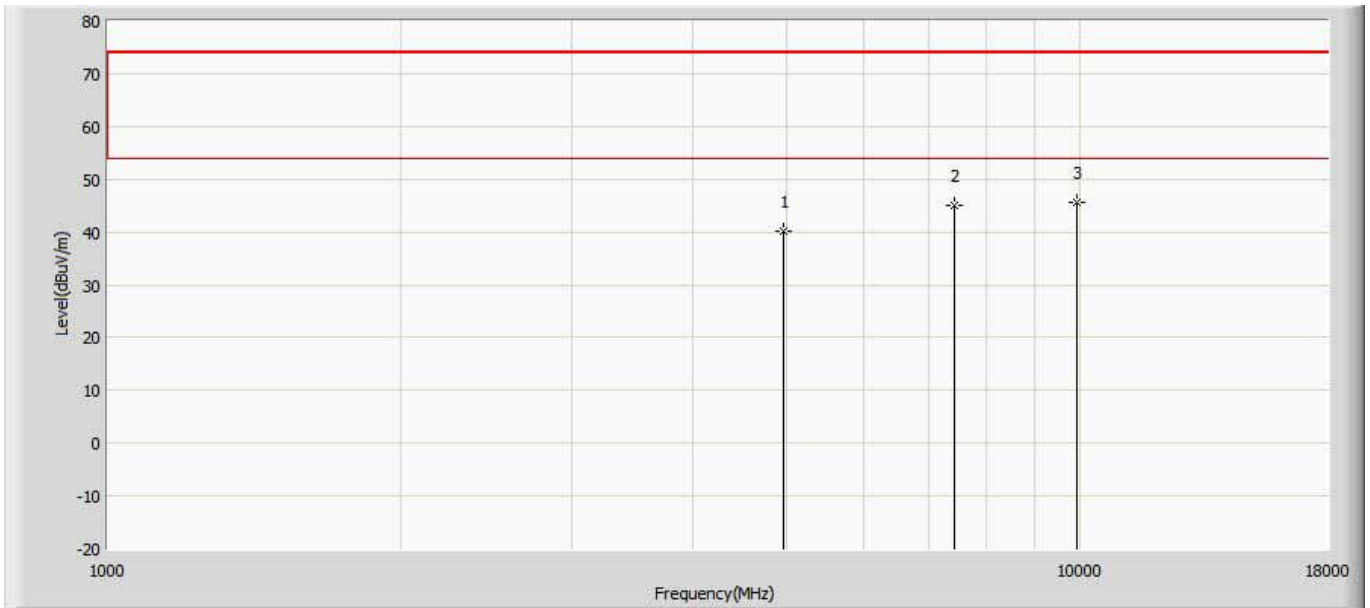

No	Mark	Frequency (MHz)	Measure Level (dBuV/m)	Reading Level (dBuV)	Over Limit (dB)	Limit (dBuV/m)	Factor (dB)	Type
1		4960.000	40.057	52.287	-33.943	74.000	-12.230	PK
2		7440.000	44.908	51.568	-29.092	74.000	-6.660	PK
3	*	9920.000	45.490	47.450	-28.510	74.000	-1.960	PK

Engineer: allen	
Site: AC5	Time: 2017/10/18 - 20:12
Limit: FCC_Part15.209_RE(3m)	Margin: 0
Probe: Horn_3117_00167055(1-18GHz)	Polarity: Vertical
EUT: LED lamp	Power: AC 120V/60Hz
Note: Mode 1:Transmit at 2480MHz by zigbee	

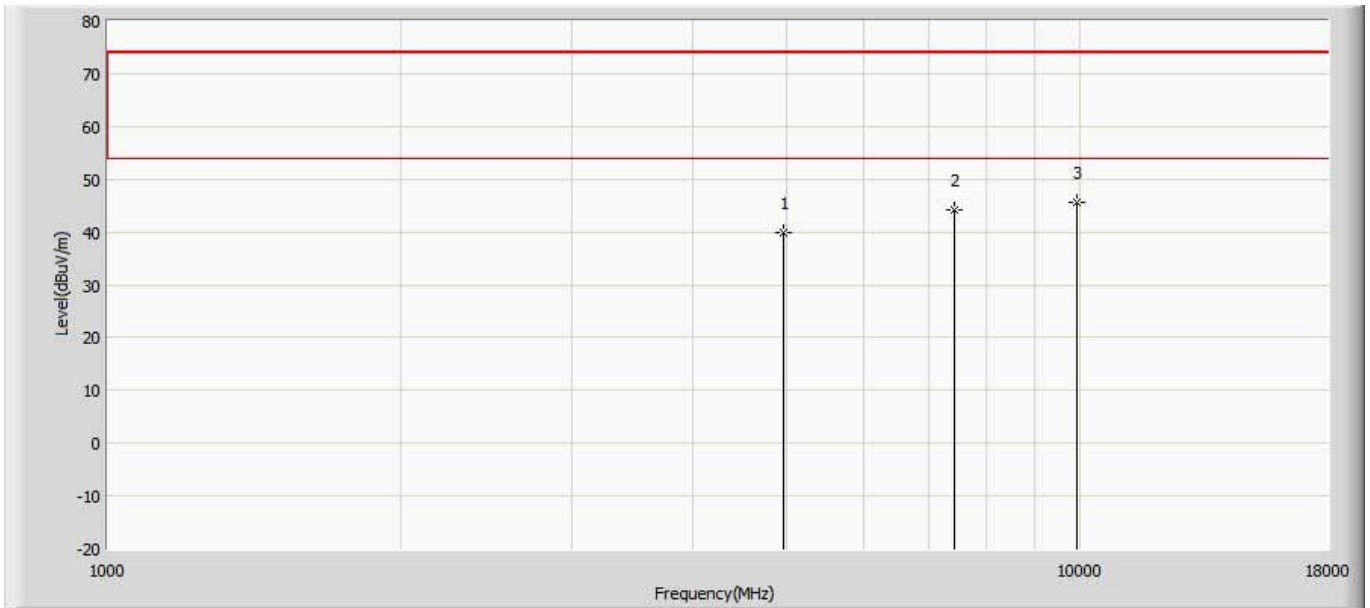

No	Mark	Frequency (MHz)	Measure Level (dBuV/m)	Reading Level (dBuV)	Over Limit (dB)	Limit (dBuV/m)	Factor (dB)	Type
1		4960.000	39.960	52.190	-34.040	74.000	-12.230	PK
2		7440.000	44.139	50.799	-29.861	74.000	-6.660	PK
3	*	9920.000	45.616	47.576	-28.384	74.000	-1.960	PK

Note:

1. Measured Level = Reading Level + Factor.
2. The test frequency range, 9kHz~30MHz, 18GHz~26GHz, both of the worst case are at least 20dB below the limits, therefore no data appear in the report.
3. This limit applies for using average detector, if the test result on peak is lower than average limit, then average measurement needn't be performed.
4. As the radiated emission was performed, so conducted emission was not tested.

The result for APT+Alvis+Murata:

Engineer: allen	
Site: AC5	Time: 2017/12/18 - 20:11
Limit: FCC_Part15.209_RE(3m)	Margin: 0
Probe: Horn_3117_00167055(1-18GHz)	Polarity: Horizontal
EUT: LED lamp	Power: AC 120V/60Hz
Note: Mode 1:Transmit at 2405MHz by zigbee	

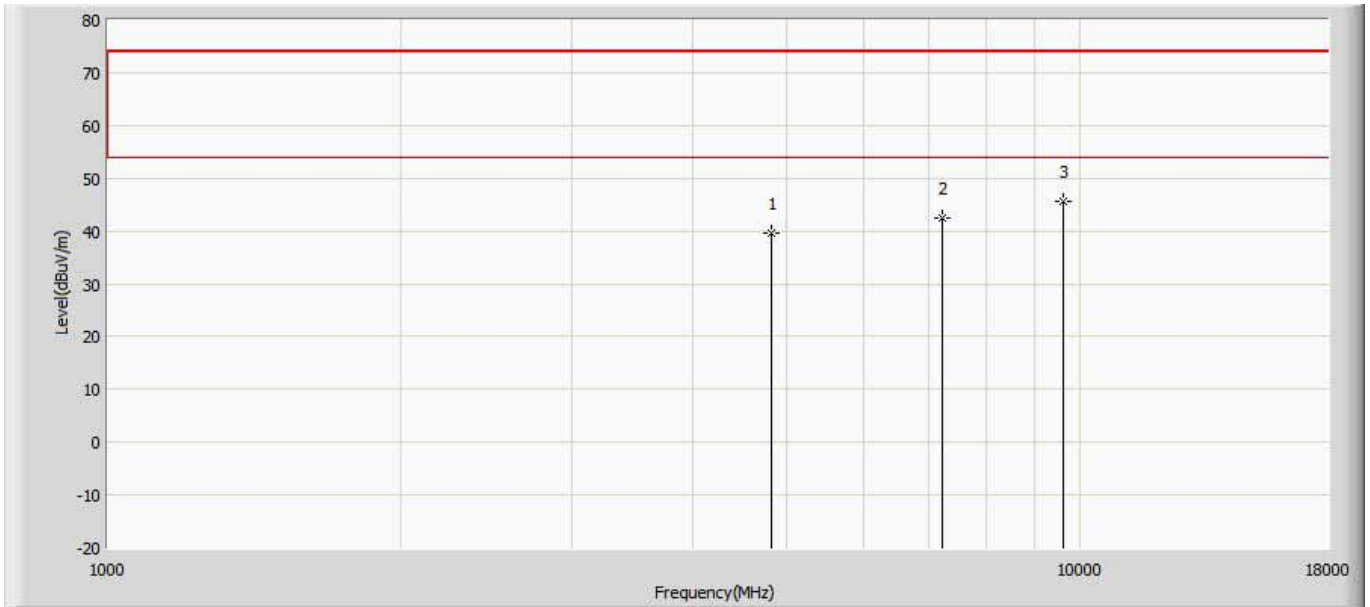

No	Mark	Frequency (MHz)	Measure Level (dBuV/m)	Reading Level (dBuV)	Over Limit (dB)	Limit (dBuV/m)	Factor (dB)	Type
1		4810.000	39.453	52.563	-34.547	74.000	-13.010	PK
2		7215.000	42.305	50.115	-31.695	74.000	-7.710	PK
3	*	9620.000	46.051	47.641	-27.949	74.000	-1.590	PK

Engineer: allen	
Site: AC5	Time: 2017/12/18 - 20:11
Limit: FCC_Part15.209_RE(3m)	Margin: 0
Probe: Horn_3117_00167055(1-18GHz)	Polarity: Vertical
EUT: LED lamp	Power: AC 120V/60Hz
Note: Mode 1:Transmit at 2405MHz by zigbee	

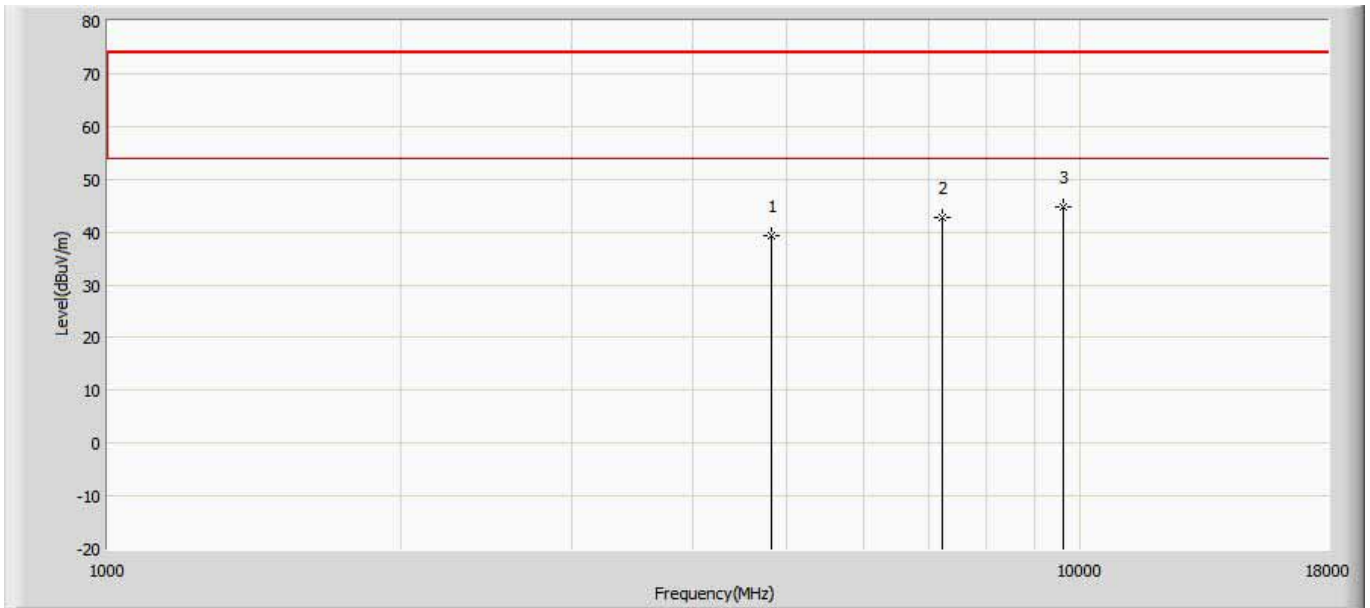

No	Mark	Frequency (MHz)	Measure Level (dBuV/m)	Reading Level (dBuV)	Over Limit (dB)	Limit (dBuV/m)	Factor (dB)	Type
1		4810.000	39.946	52.956	-34.054	74.000	-13.010	PK
2		7215.000	43.261	50.971	-30.739	74.000	-7.710	PK
3	*	9620.000	44.835	46.425	-29.165	74.000	-1.590	PK

Engineer: allen	
Site: AC5	Time: 2017/12/18 - 20:12
Limit: FCC_Part15.209_RE(3m)	Margin: 0
Probe: Horn_3117_00167055(1-18GHz)	Polarity: Horizontal
EUT: LED lamp	Power: AC 120V/60Hz
Note: Mode 1:Transmit at 2450MHz by zigbee	

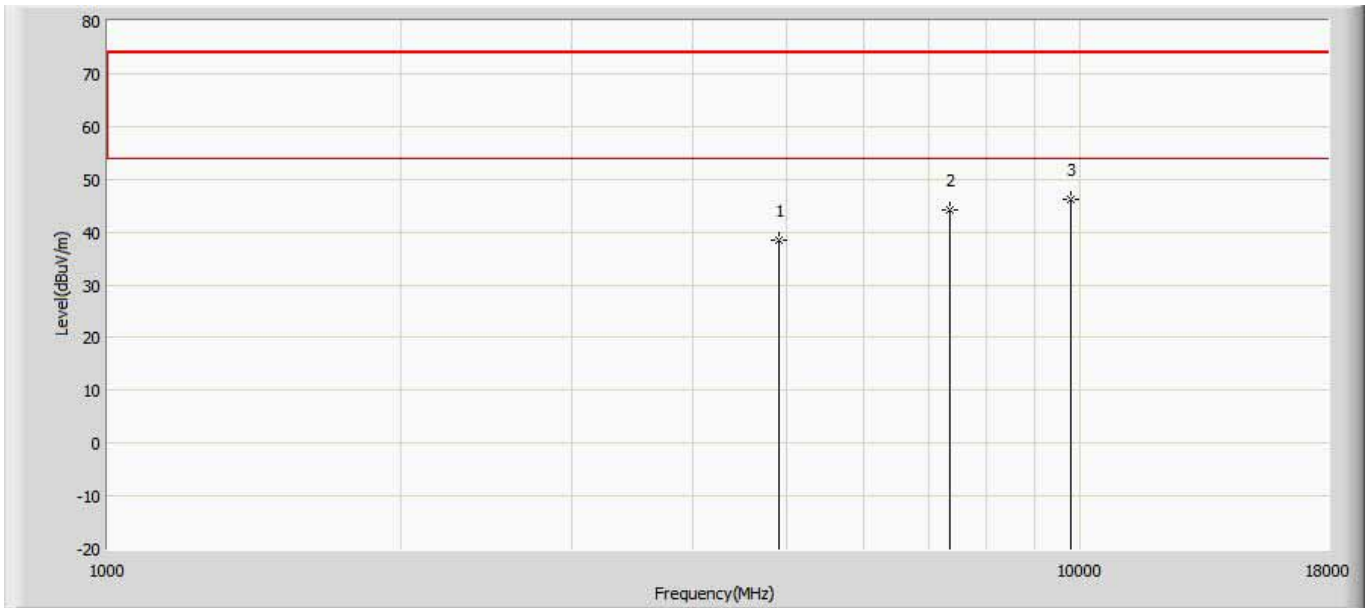

No	Mark	Frequency (MHz)	Measure Level (dBuV/m)	Reading Level (dBuV)	Over Limit (dB)	Limit (dBuV/m)	Factor (dB)	Type
1		4900.000	38.927	51.937	-35.073	74.000	-13.010	PK
2		7350.000	44.097	51.807	-29.903	74.000	-7.710	PK
3	*	9800.000	47.038	48.628	-26.962	74.000	-1.590	PK

Engineer: allen	
Site: AC5	Time: 2017/12/18 - 20:12
Limit: FCC_Part15.209_RE(3m)	Margin: 0
Probe: Horn_3117_00167055(1-18GHz)	Polarity: Vertical
EUT: LED lamp	Power: AC 120V/60Hz
Note: Mode 1:Transmit at 2450MHz by zigbee	

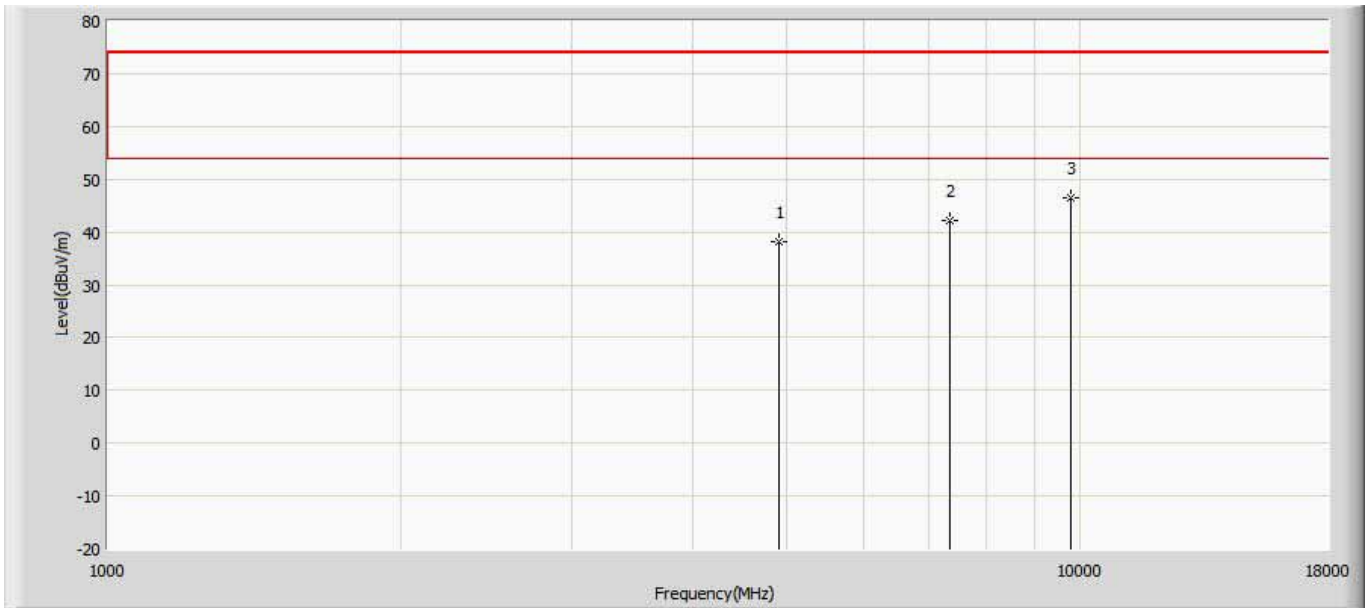

No	Mark	Frequency (MHz)	Measure Level (dBuV/m)	Reading Level (dBuV)	Over Limit (dB)	Limit (dBuV/m)	Factor (dB)	Type
1		4900.000	38.240	51.250	-35.760	74.000	-13.010	PK
2		7350.000	42.586	50.296	-31.414	74.000	-7.710	PK
3	*	9800.000	46.751	48.341	-27.249	74.000	-1.590	PK

Engineer: allen	
Site: AC5	Time: 2017/12/18 - 20:12
Limit: FCC_Part15.209_RE(3m)	Margin: 0
Probe: Horn_3117_00167055(1-18GHz)	Polarity: Horizontal
EUT: LED lamp	Power: AC 120V/60Hz
Note: Mode 1:Transmit at 2480MHz by zigbee	

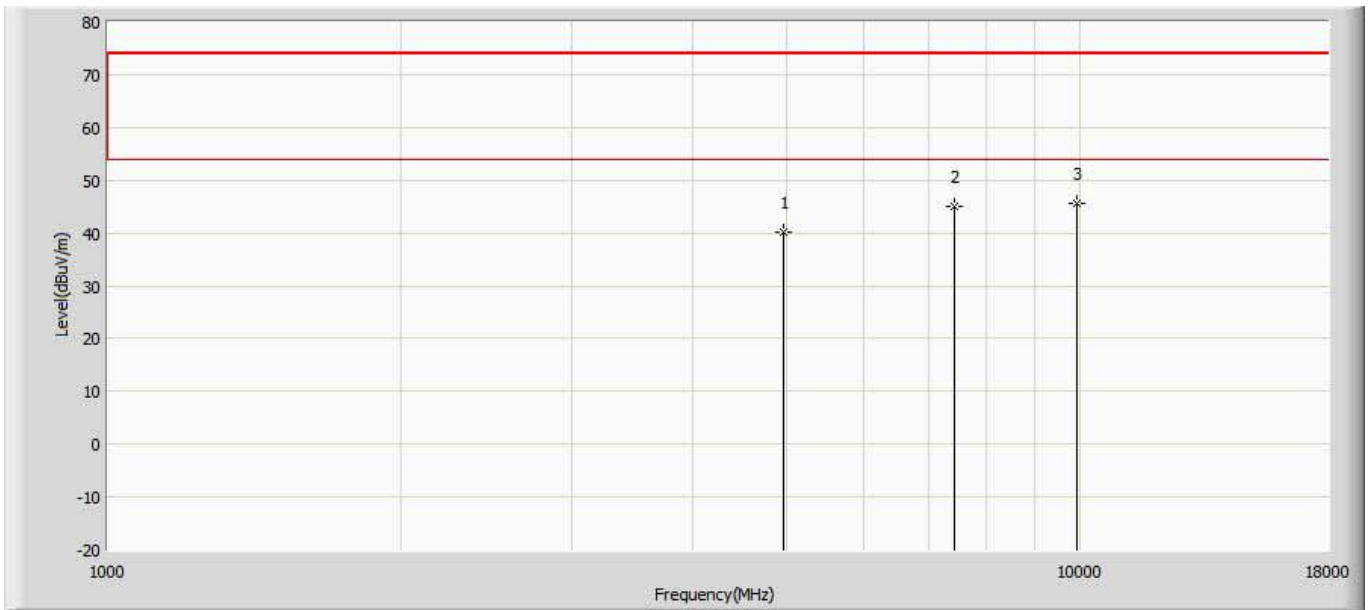

No	Mark	Frequency (MHz)	Measure Level (dBuV/m)	Reading Level (dBuV)	Over Limit (dB)	Limit (dBuV/m)	Factor (dB)	Type
1		4960.000	40.392	52.622	-33.608	74.000	-12.230	PK
2		7440.000	45.841	52.501	-28.159	74.000	-6.660	PK
3	*	9920.000	46.006	47.966	-27.994	74.000	-1.960	PK

Engineer: allen	
Site: AC5	Time: 2017/12/18 - 20:12
Limit: FCC_Part15.209_RE(3m)	Margin: 0
Probe: Horn_3117_00167055(1-18GHz)	Polarity: Vertical
EUT: LED lamp	Power: AC 120V/60Hz
Note: Mode 1:Transmit at 2480MHz by zigbee	

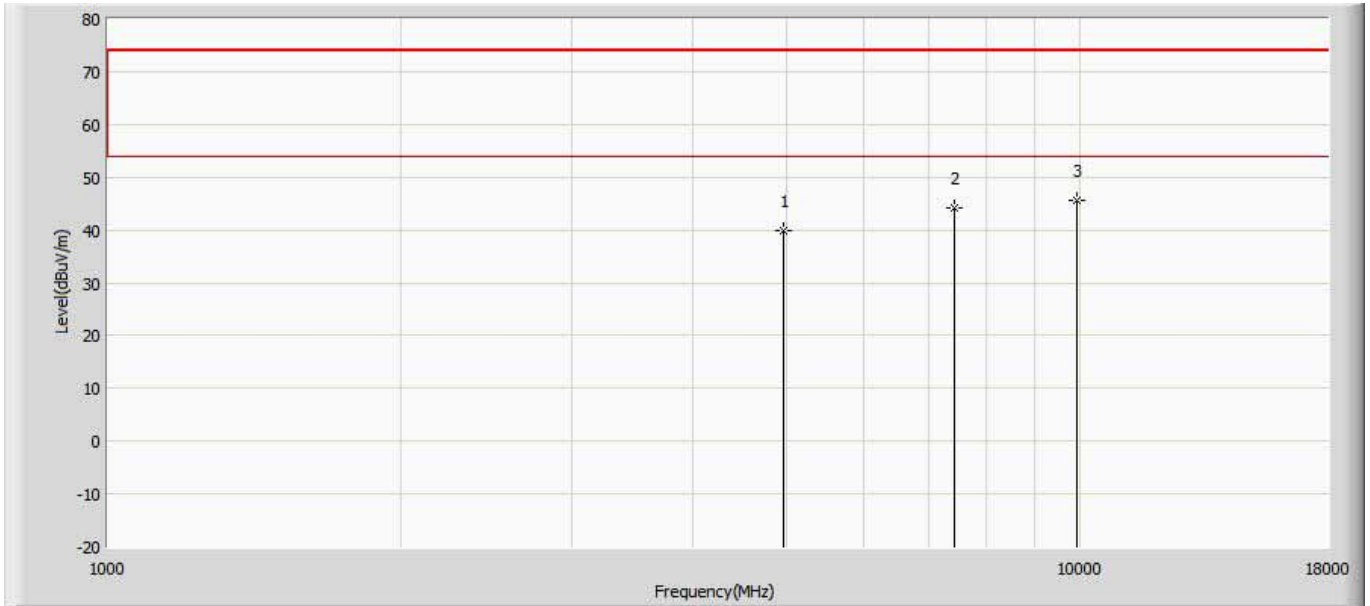

No	Mark	Frequency (MHz)	Measure Level (dBuV/m)	Reading Level (dBuV)	Over Limit (dB)	Limit (dBuV/m)	Factor (dB)	Type
1		4960.000	40.918	53.148	-33.082	74.000	-12.230	PK
2		7440.000	44.510	51.170	-29.490	74.000	-6.660	PK
3	*	9920.000	45.857	47.817	-28.143	74.000	-1.960	PK

Note:

1. Measured Level = Reading Level + Factor.
2. The test frequency range, 9kHz~30MHz, 18GHz~26GHz, both of the worst case are at least 20dB below the limits, therefore no data appear in the report.
3. This limit applies for using average detector, if the test result on peak is lower than average limit, then average measurement needn't be performed.
4. As the radiated emission was performed, so conducted emission was not tested.

**The worst case of Radiated Emission below 1GHz:
The result for APT+Alvis+Diodes:**

Engineer: Lei-wan	
Site: AC2	Time: 2017/09/04 - 11:16
Limit: FCC_Part15.109_RE(3m)_ClassB	Margin: 0
Probe: AC2_3M(30-1000M)	Polarity: Horizontal
EUT: LED lamp	Power: AC 120V/60Hz
Note: Mode 1:Transmit at 2450MHz by zigbee	

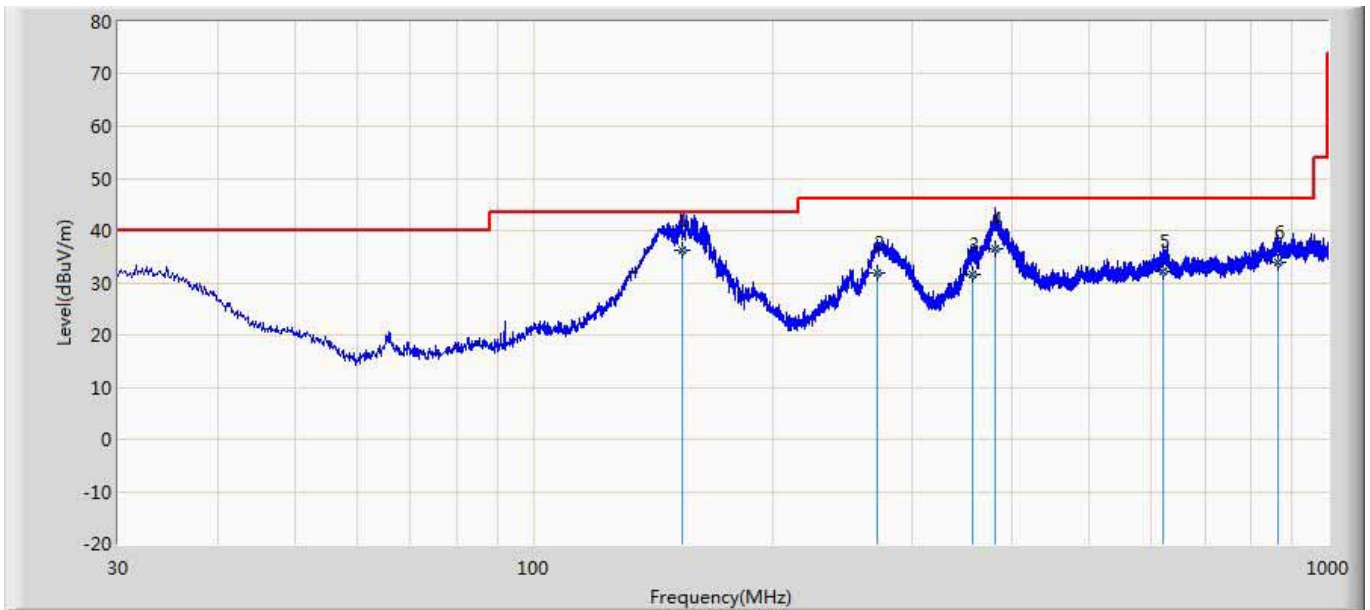

No	Mark	Frequency (MHz)	Measure Level (dBuV/m)	Reading Level (dBuV)	Over Limit (dB)	Limit (dBuV/m)	Probe (dB/m)	Cable (dB)	Amp (dB)	Ant Pos (cm)	Table Pos (deg)	Type
1	*	153.839	36.171	19.100	-7.329	43.500	9.862	7.209	0.000	200	45	QP
2		271.389	31.888	12.663	-14.112	46.000	11.633	7.592	0.000	200	186	QP
3		357.235	31.452	7.325	-14.548	46.000	16.319	7.808	0.000	200	325	QP
4		381.883	36.631	11.963	-9.369	46.000	16.778	7.889	0.000	200	96	QP
5		620.336	32.047	1.210	-13.953	46.000	22.278	8.558	0.000	200	142	QP
6		865.365	34.013	1.031	-11.987	46.000	23.815	9.166	0.000	200	213	QP

Note:

1. All Readings below 1GHz are Quasi-Peak, above are performed with peak and/or average measurements as necessary.
2. " * ", means this data is the worst emission level.
3. Measurement Level = Reading Level + Factor(Probe+Cable-Amp).

Engineer: Lei-wan	
Site: AC2	Time: 2017/09/04 - 11:19
Limit: FCC_Part15.109_RE(3m)_ClassB	Margin: 0
Probe: AC2_3M(30-1000M)	Polarity: Vertical
EUT: LED lamp	Power: AC 120V/60Hz
Note: Mode 1:Transmit at 2450MHz by zigbee	

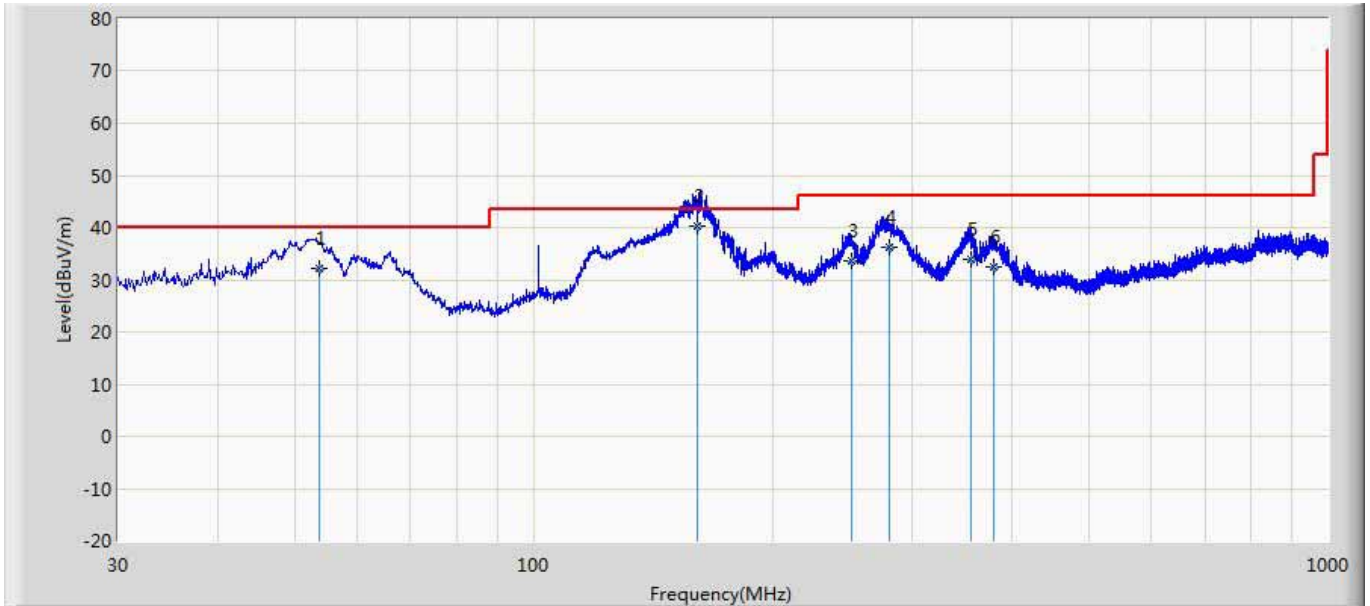

No	Mark	Frequency (MHz)	Measure Level (dBuV/m)	Reading Level (dBuV)	Over Limit (dB)	Limit (dBuV/m)	Probe (dB/m)	Cable (dB)	Amp (dB)	Ant Pos (cm)	Table Pos (deg)	Type
1		53.692	32.210	14.106	-7.790	40.000	11.496	6.608	0.000	100	79	QP
2	*	160.928	40.234	21.300	-3.266	43.500	11.682	7.252	0.000	100	41	QP
3		251.102	33.665	9.009	-12.335	46.000	17.086	7.571	0.000	100	146	QP
4		279.980	36.266	11.250	-9.734	46.000	17.416	7.600	0.000	100	214	QP
5		355.032	34.011	8.782	-11.989	46.000	17.427	7.801	0.000	100	166	QP
6		379.553	32.480	9.063	-13.520	46.000	15.536	7.881	0.000	100	149	QP

Note:

1. All Readings below 1GHz are Quasi-Peak, above are performed with peak and/or average measurements as necessary.
2. " * ", means this data is the worst emission level.
3. Measurement Level = Reading Level + Factor(Probe+Cable-Amp).

The result for LTN+Alvis+Diodes:

Engineer: Lei-wan	
Site: AC2	Time: 2017/09/04 - 10:35
Limit: FCC_Part15.109_RE(3m)_ClassB	Margin: 0
Probe: AC2_3M(30-1000M)	Polarity: Horizontal
EUT: LED lamp	Power: AC 120V/60Hz
Note: Mode 1:Transmit at 2450MHz by zigbee	

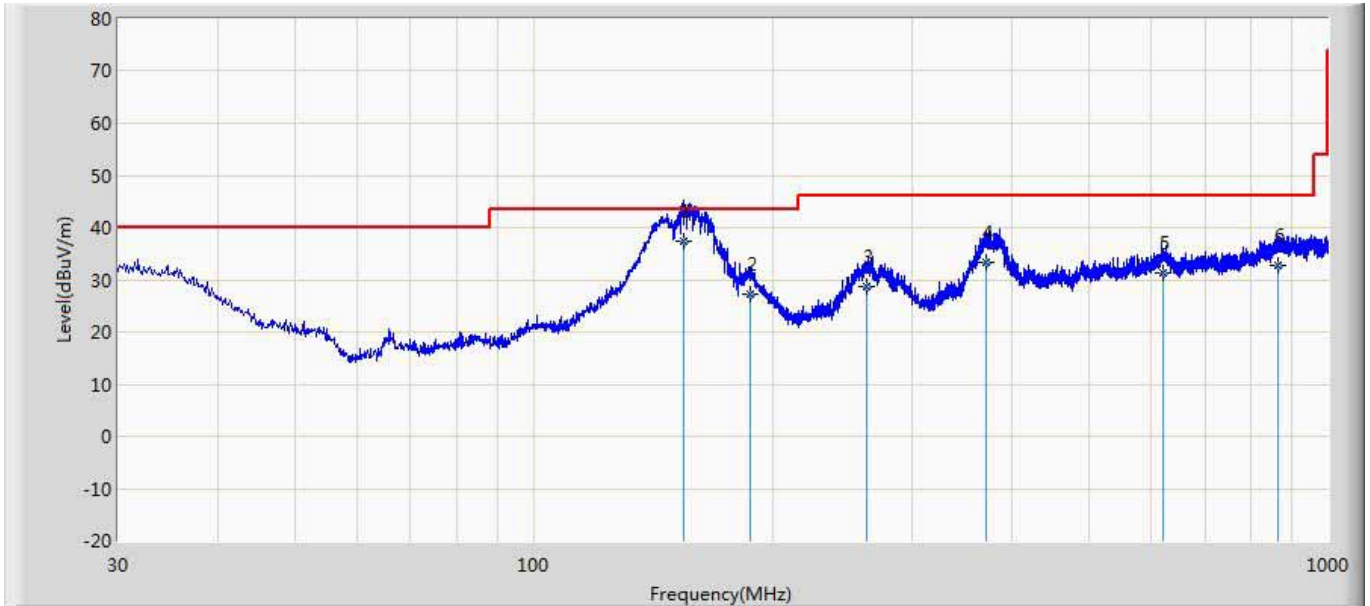

No	Mark	Frequency (MHz)	Measure Level (dBuV/m)	Reading Level (dBuV)	Over Limit (dB)	Limit (dBuV/m)	Probe (dB/m)	Cable (dB)	Amp (dB)	Ant Pos (cm)	Table Pos (deg)	Type
1	*	154.780	37.497	20.400	-6.003	43.500	9.882	7.215	0.000	200	52	QP
2		187.670	27.268	10.062	-16.232	43.500	9.891	7.315	0.000	200	132	QP
3		263.182	28.761	9.780	-17.239	46.000	11.398	7.583	0.000	200	92	QP
4		371.860	33.459	9.365	-12.541	46.000	16.238	7.856	0.000	100	79	QP
5		618.903	31.215	0.552	-14.785	46.000	22.108	8.554	0.000	200	161	QP
6		864.023	32.892	0.003	-13.108	46.000	23.726	9.163	0.000	200	151	QP

Note:

1. All Readings below 1GHz are Quasi-Peak, above are performed with peak and/or average measurements as necessary.
2. " * ", means this data is the worst emission level.
3. Measurement Level = Reading Level + Factor(Probe+Cable-Amp).

Engineer: Lei-wan	
Site: AC2	Time: 2017/09/04 - 10:38
Limit: FCC_Part15.109_RE(3m)_ClassB	Margin: 0
Probe: AC2_3M(30-1000M)	Polarity: Vertical
EUT: LED lamp	Power: AC 120V/60Hz
Note: Mode 1:Transmit at 2450MHz by zigbee	

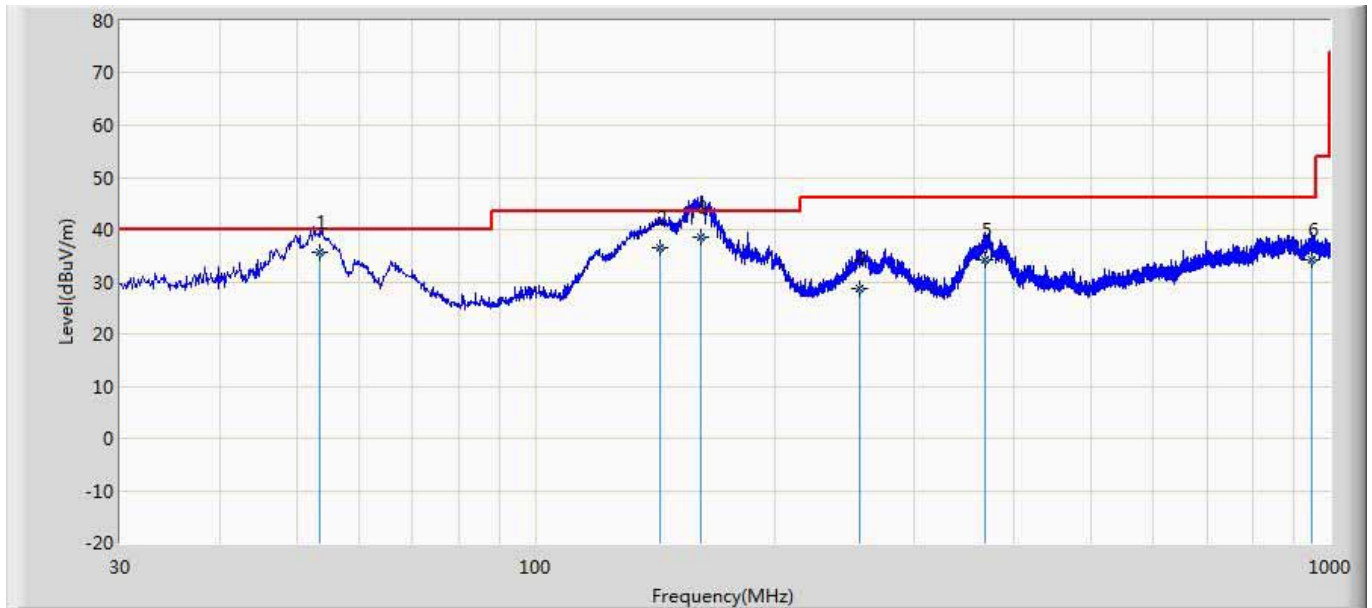

No	Mark	Frequency (MHz)	Measure Level (dBuV/m)	Reading Level (dBuV)	Over Limit (dB)	Limit (dBuV/m)	Probe (dB/m)	Cable (dB)	Amp (dB)	Ant Pos (cm)	Table Pos (deg)	Type
1	*	53.499	35.585	17.400	-4.415	40.000	11.581	6.605	0.000	100	319	QP
2		143.378	36.404	18.400	-7.096	43.500	10.866	7.138	0.000	100	6	QP
3		161.558	38.454	19.400	-5.046	43.500	11.800	7.254	0.000	100	167	QP
4		255.384	28.640	4.200	-17.360	46.000	16.864	7.575	0.000	200	238	QP
5		368.012	34.297	10.300	-11.703	46.000	16.154	7.843	0.000	200	51	QP
6		949.325	34.324	1.012	-11.676	46.000	23.964	9.349	0.000	200	76	QP

Note:

1. All Readings below 1GHz are Quasi-Peak, above are performed with peak and/or average measurements as necessary.
2. " * ", means this data is the worst emission level.
3. Measurement Level = Reading Level + Factor(Probe+Cable-Amp).

The result for APT+Alvis+Murata:

Engineer: Samuel	
Site: AC3	Time: 2017/10/09 - 16:36
Limit: FCC_Part15.109_RE(3m)_ClassB	Margin: 0
Probe: AC3_3m (30-1000MHz)	Polarity: Horizontal
EUT: LED Lamp	Power: AC 120V/60Hz

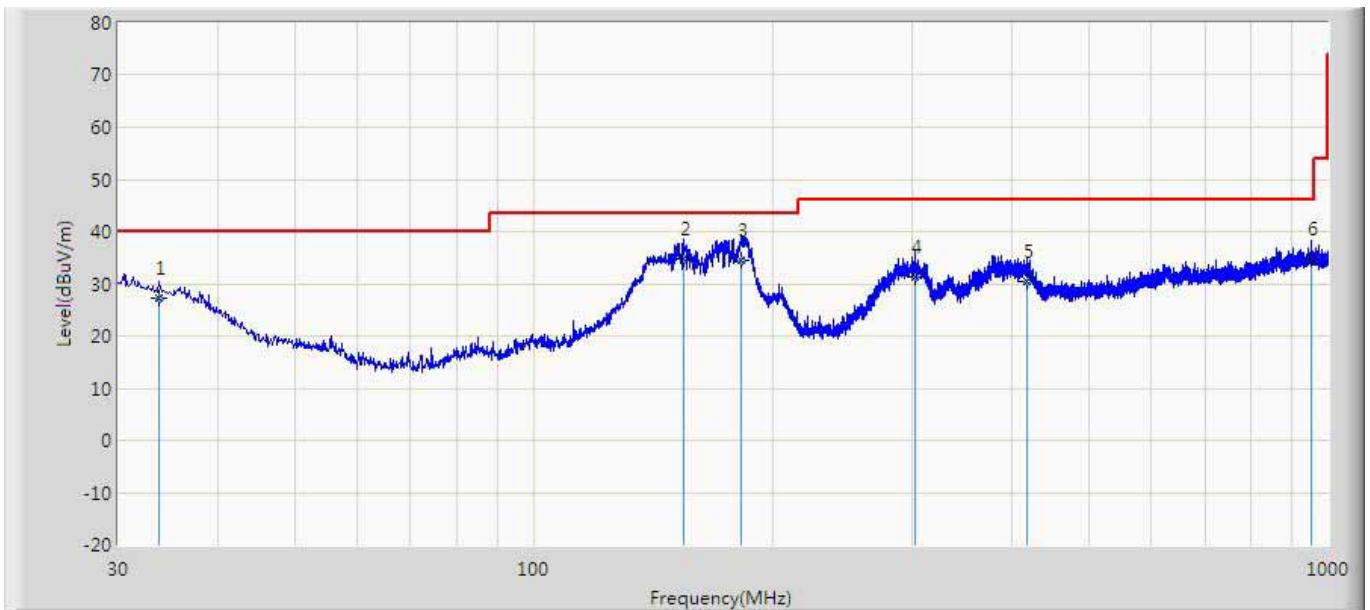

No	Mark	Frequency (MHz)	Measure Level (dBuV/m)	Reading Level (dBuV)	Over Limit (dB)	Limit (dBuV/m)	Probe (dB/m)	Cable (dB)	Amp (dB)	Ant Pos (cm)	Table Pos (deg)	Type
1		33.760	27.214	1.200	-12.786	40.000	19.534	6.479	0.000	100	181	QP
2	*	154.646	34.656	17.300	-8.844	43.500	10.258	7.098	0.000	200	194	QP
3		182.919	34.576	17.400	-8.924	43.500	9.961	7.216	0.000	200	279	QP
4		302.450	31.259	10.700	-14.741	46.000	12.936	7.623	0.000	100	164	QP
5		417.637	30.449	3.600	-15.551	46.000	18.894	7.955	0.000	100	304	QP
6		951.865	34.902	2.100	-11.098	46.000	23.597	9.205	0.000	100	235	QP

Note:

1. " * ", means this data is the worst emission level.
2. Measurement Level = Reading Level + Factor(Probe+Cable-Amp).

Engineer: Samuel	
Site: AC3	Time: 2017/10/09 - 16:38
Limit: FCC_Part15.109_RE(3m)_ClassB	Margin: 0
Probe: AC3_3m (30-1000MHz)	Polarity: Vertical
EUT: LED Lamp	Power: AC 120V/60Hz

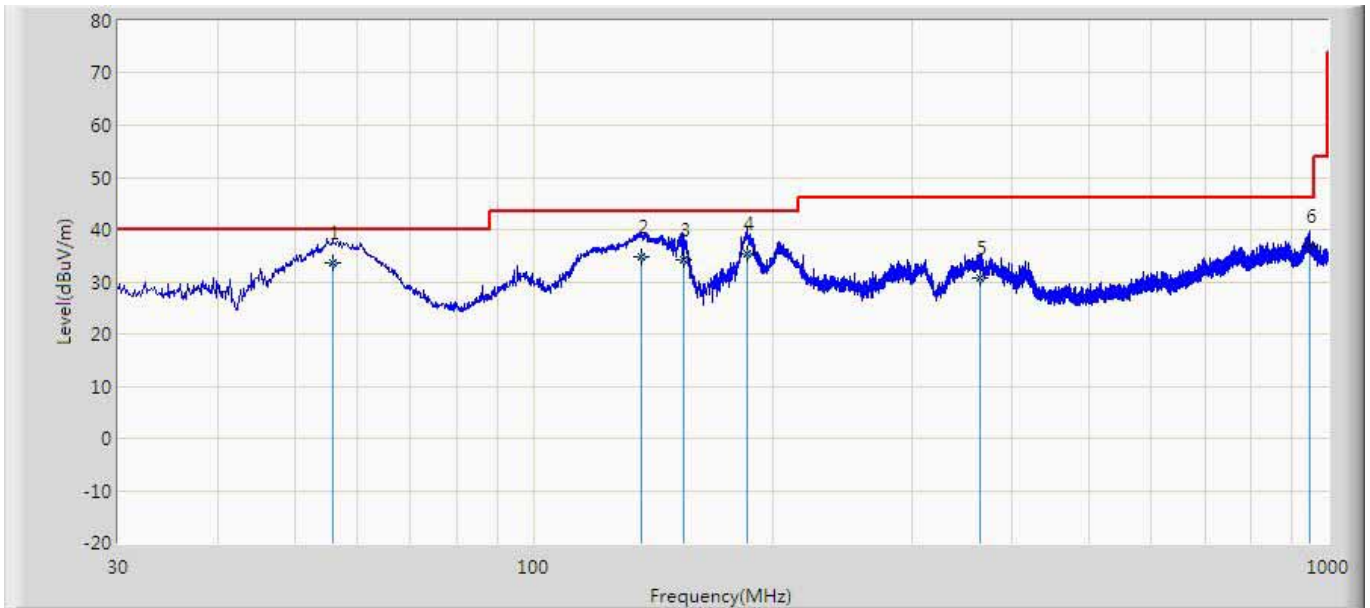

No	Mark	Frequency (MHz)	Measure Level (dBuV/m)	Reading Level (dBuV)	Over Limit (dB)	Limit (dBuV/m)	Probe (dB/m)	Cable (dB)	Amp (dB)	Ant Pos (cm)	Table Pos (deg)	Type
1	*	55.842	33.484	16.900	-6.516	40.000	9.962	6.622	0.000	100	166	QP
2		136.943	34.748	14.600	-8.752	43.500	13.125	7.024	0.000	200	149	QP
3		154.766	34.087	15.400	-9.413	43.500	11.588	7.099	0.000	200	212	QP
4		185.483	35.415	14.700	-8.085	43.500	13.489	7.226	0.000	100	228	QP
5		364.529	30.788	6.700	-15.212	46.000	16.281	7.807	0.000	100	197	QP
6		947.256	36.713	1.900	-9.287	46.000	25.616	9.197	0.000	100	300	QP

Note:

1. " * ", means this data is the worst emission level.
2. Measurement Level = Reading Level + Factor(Probe+Cable-Amp).

5. Emissions in non-restricted frequency bands

5.1. Test Equipment

Emissions in non-restricted frequency bands / TR-8					
Instrument	Manufacturer	Type No.	Serial No.	Cal. Date	Cal. Due Date
Spectrum Analyzer	Agilent	N9010A	MY48030494	2017.02.04	2018.02.03
EXA Spectrum Analyzer	Keysight	N9010A	MY55370495	2017.04.09	2018.04.08
MXA Signal Analyzer	Keysight	N9020A	MY56060147	2017.04.09	2018.04.08
Temperature/Humidity Meter	zhichen	ZC1-2	TR8-TH	2017.04.10	2018.04.09

Note: All equipment are calibrated with traceable calibrations. Each calibration is traceable to the national or international standards.

5.2. Test Setup

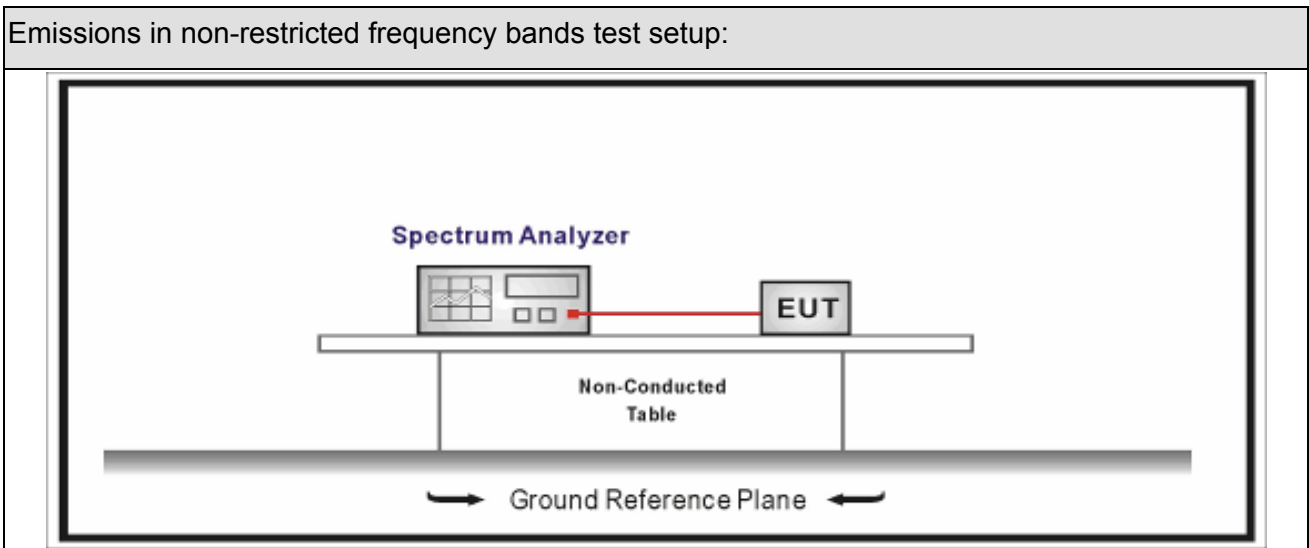





5.3. Limit

Un-Restricted Band Emissions Limit	
RF Output power (Detection methods)	Limit(dB)
RF Output power(Average detector)	30c(Note1)
RF Output power(PK detector)	20c(Note2)
<p>Note 1: If maximum conducted (average) output power was used to demonstrate compliance as described in 9.2, then the peak power in any 100 kHz bandwidth outside of the authorized frequency band shall be attenuated by at least 30 dB relative to the maximum in-band peak PSD level in 100 kHz (i.e., 30 dBc).</p> <p>Note 2: If the maximum peak conducted output power procedure was used, then the peak output power measured in any 100 kHz bandwidth outside of the authorized frequency band shall be attenuated by at least 20 dB relative to the maximum in-band peak PSD level in 100 kHz (i.e., 20 dBc).</p>	

5.4. Test Procedure

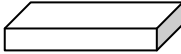
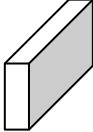
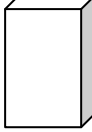
Test Method			
	References Rule	Chapter	Description
<input checked="" type="checkbox"/>	ANSI C63.10	11.11	Emissions in non-restricted frequency bands
	<input checked="" type="checkbox"/> ANSI C63.10	11.11.2	Reference level measurement
	<input checked="" type="checkbox"/> ANSI C63.10	11.11.3	Emission level measurement
<input type="checkbox"/>	ANSI C63.10	11.12	Emissions in restricted frequency bands
	<input type="checkbox"/> ANSI C63.10	11.12.1	Radiated emission measurements
	<input type="checkbox"/> ANSI C63.10	11.12.2.7	Radiated spurious emission test
<input type="checkbox"/>	ANSI C63.10	6.4	Radiated emissions from unlicensed wireless devices below 30 MHz
<input type="checkbox"/>	ANSI C63.10	6.5	Radiated emissions from unlicensed wireless devices in the frequency range of 30 MHz to 1000 MHz
<input type="checkbox"/>	ANSI C63.10	6.6	Radiated emissions from unlicensed wireless devices above 1 GHz
	<input checked="" type="checkbox"/> ANSI C63.10	11.12.2	Antenna-port conducted measurements
	<input type="checkbox"/> ANSI C63.10	11.12.2.3	Quasi-peak measurement procedure
	<input checked="" type="checkbox"/> ANSI C63.10	11.12.2.4	Peak power measurement procedure
	<input type="checkbox"/> ANSI C63.10	11.12.2.5	Average power measurement procedures
	<input type="checkbox"/> ANSI C63.10	11.12.2.5.1	Trace averaging with continuous EUT transmission at full power
	<input type="checkbox"/> ANSI C63.10	11.12.2.5.2	Trace averaging across ON and OFF times of the EUT transmissions followed by duty cycle correction
	<input type="checkbox"/> ANSI C63.10	11.12.2.5.3	Reduced VBW averaging across ON and OFF times of the EUT transmissions with max hold

5.5. EUT test Axis definition

Item	Emissions in non-restricted frequency bands			
Device Category	<input type="checkbox"/>	Fixed point-to-point		
	<input type="checkbox"/>	Emit multiple directional beams, simultaneously or sequentially		
	<input checked="" type="checkbox"/>	Other cases		
Test mode	Mode 1			
Test method	<input type="checkbox"/>	Radiated		
		X Axis	Y Axis	Z Axis
				
		Worst Axis <input type="checkbox"/>	Worst Axis <input type="checkbox"/>	Worst Axis <input type="checkbox"/>
	<input checked="" type="checkbox"/>	Conducted		
	<input checked="" type="checkbox"/>	Chain 0		
				
	<input type="checkbox"/>	Chain 0	Chain 1	
				
	<input type="checkbox"/>	Chain 0	Chain 1	Chain 2
				

5.6. Test Result

Product Name	: LED lamp	Power	: AC 120V/60Hz
Test Mode	: Mode 1	Test Site	: TR-8
Test Date	: 2017.09.22	Test engineer	: Tommy

Mode	Channel	Test Frequency (MHz)	In-Band PSD[a] (dBm/100kHz)	Frequency (MHz)	Out-Band PSD[b] (dBm/100kHz)	[a]-[b] (dB)	Limit (dB)	Result
1	11	2405	1.218	2400.00	-50.003	51.221	>20	Pass
1	26	2480	-0.541	2500.00	-68.113	67.572	>20	Pass

Note: The worst case of Emissions in non-restricted frequency bands as below:

Mode 1 CH11 (2405MHz)

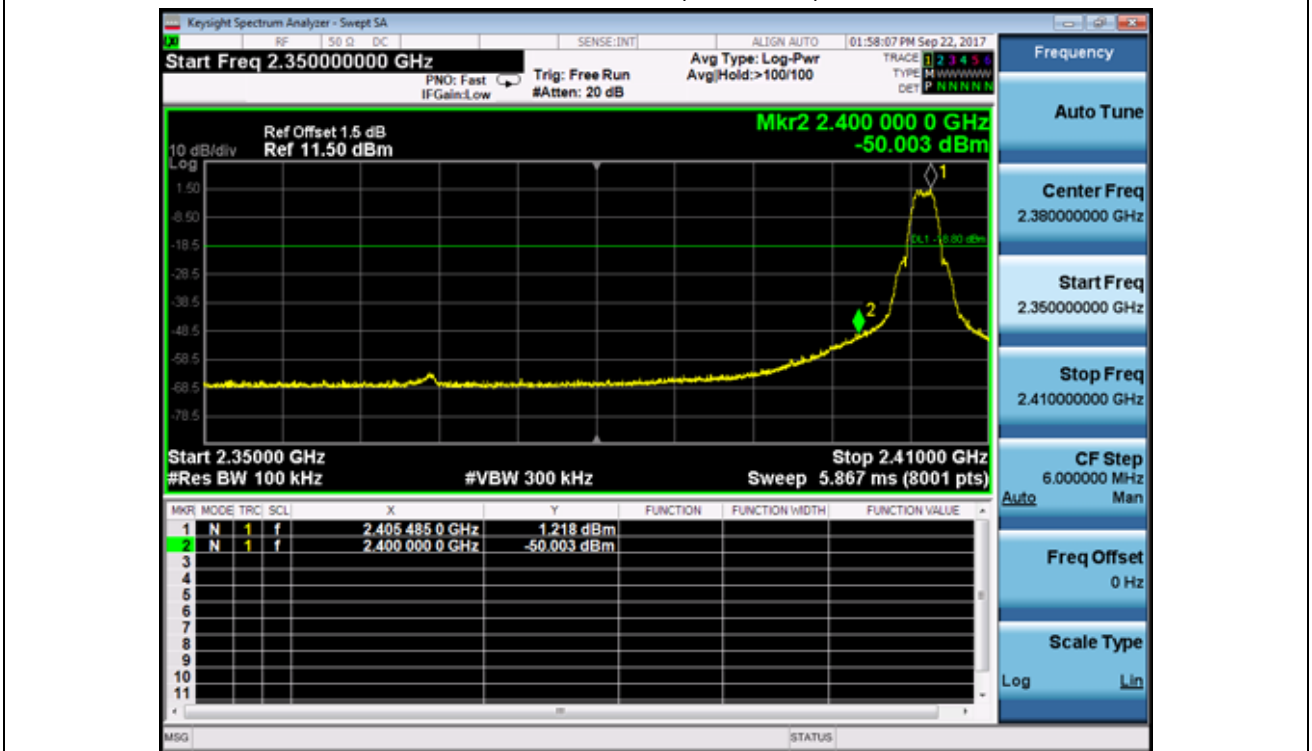

6. Radiated Emission Band Edge

6.1. Test Equipment

Radiated Emission(Above 1GHz) / AC-5					
Instrument	Manufacturer	Type No.	Serial No.	Cal. Date	Cal. Due Date
EMI Receiver	Agilent	N9038A	MY51210196	2017.07.16	2018.07.15
Pre-Amplifier	Miteq	NSP1800-25	1364185	2017.05.03	2018.05.02
DRG Horn Antenna	ETS-Lindgren	3117	00167055	2017.07.12	2018.07.11
Broad-Band Horn Antenna	Schwarzbeck	BBHA9170	294	2017.09.18	2018.09.17
Coaxial Cable	Huber+Suhner	SUCOFLEX 106	AC5-C1	2017.02.28	2018.02.27
Coaxial Cable	Huber+Suhner	SUCOFLEX 106	AC5-C2	2017.02.28	2018.02.27
Temperature/Humidity Meter	Zhichen	ZC1-2	AC5-TH	2017.01.05	2018.01.04

6.2. Test Setup

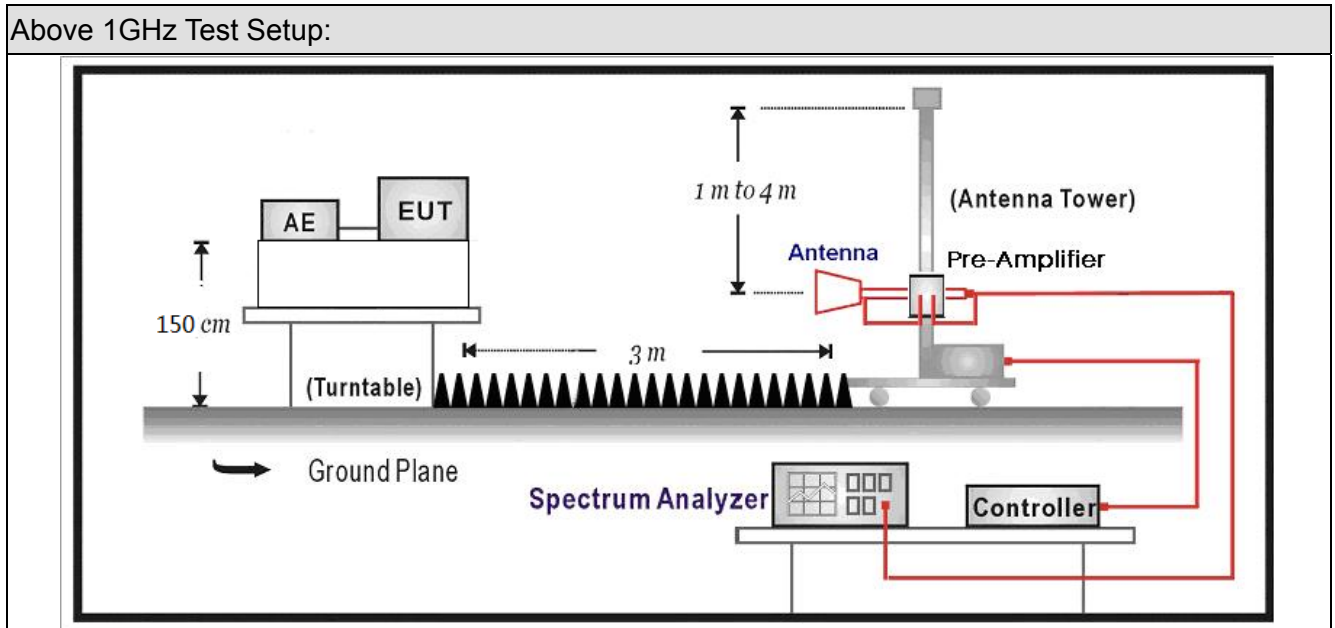

6.3. Limit





Band edge Limit				
Frequency bands (MHz)	Detector	Limit (dB μ V/m)	RBW (MHz)	Distance (m)
2310-2390	PK	74	1	3
2483.5-2500	AV	54	1	3

Note: The field strength of emissions appearing within these frequency bands shall not exceed the limits.

6.4. Test Procedure

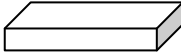
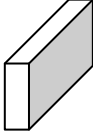
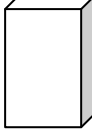
Test Method				
	References Rule		Chapter	Description
<input checked="" type="checkbox"/>	ANSI C63.10		6.10	Band-edge testing
	<input checked="" type="checkbox"/>	ANSI C63.10	6.10.5	Restricted-band band-edge measurements
	<input type="checkbox"/>	ANSI C63.10	6.10.6	Marker-delta method
<input checked="" type="checkbox"/>	ANSI C63.10		11.12	Emissions in restricted frequency bands
	<input checked="" type="checkbox"/>	ANSI C63.10	11.12.1	Radiated emission measurements
	<input checked="" type="checkbox"/>	ANSI C63.10	11.12.2.7	Radiated spurious emission test
<input type="checkbox"/>	ANSI C63.10		6.4	Radiated emissions from unlicensed wireless devices below 30 MHz
<input type="checkbox"/>	ANSI C63.10		6.5	Radiated emissions from unlicensed wireless devices in the frequency range of 30 MHz to 1000 MHz
<input checked="" type="checkbox"/>	ANSI C63.10		6.6	Radiated emissions from unlicensed wireless devices above 1 GHz
	<input type="checkbox"/>	ANSI C63.10	11.12.2.3	Quasi-peak measurement procedure
	<input checked="" type="checkbox"/>	ANSI C63.10	11.12.2.4	Peak power measurement procedure
	<input checked="" type="checkbox"/>	ANSI C63.10	11.12.2.5	Average power measurement procedures
	<input type="checkbox"/>	ANSI C63.10	11.12.2.5.1	Trace averaging with continuous EUT transmission at full power
	<input type="checkbox"/>	ANSI C63.10	11.12.2.5.2	Trace averaging across ON and OFF times of the EUT transmissions followed by duty cycle correction
	<input checked="" type="checkbox"/>	ANSI C63.10	11.12.2.5.3	Reduced VBW averaging across ON and OFF times of the EUT transmissions with max hold

6.5. EUT test definition

Item	Radiated Emission Band Edge			
Device Category	<input type="checkbox"/>	Fixed point-to-point		
	<input type="checkbox"/>	Emit multiple directional beams, simultaneously or sequentially		
	<input checked="" type="checkbox"/>	Other cases		
Test mode	Mode 1			
Test method	<input checked="" type="checkbox"/>	Radiated		
		X Axis	Y Axis	Z Axis
				
		Worst Axis <input checked="" type="checkbox"/>	Worst Axis <input type="checkbox"/>	Worst Axis <input type="checkbox"/>
	<input type="checkbox"/>	Conducted		
	<input type="checkbox"/>	Chain 0		
				
	<input type="checkbox"/>	Chain 0	Chain 1	
				
	<input type="checkbox"/>	Chain 0	Chain 1	Chain 2
				

6.6. Duty Cycle

Test Mode	Tx On (ms)	Tx Off (ms)	Reduced VBW (kHz)	Tx On + Tx Off (ms)	Duty Cycle
Zigbee	-	-	10Hz	-	100%

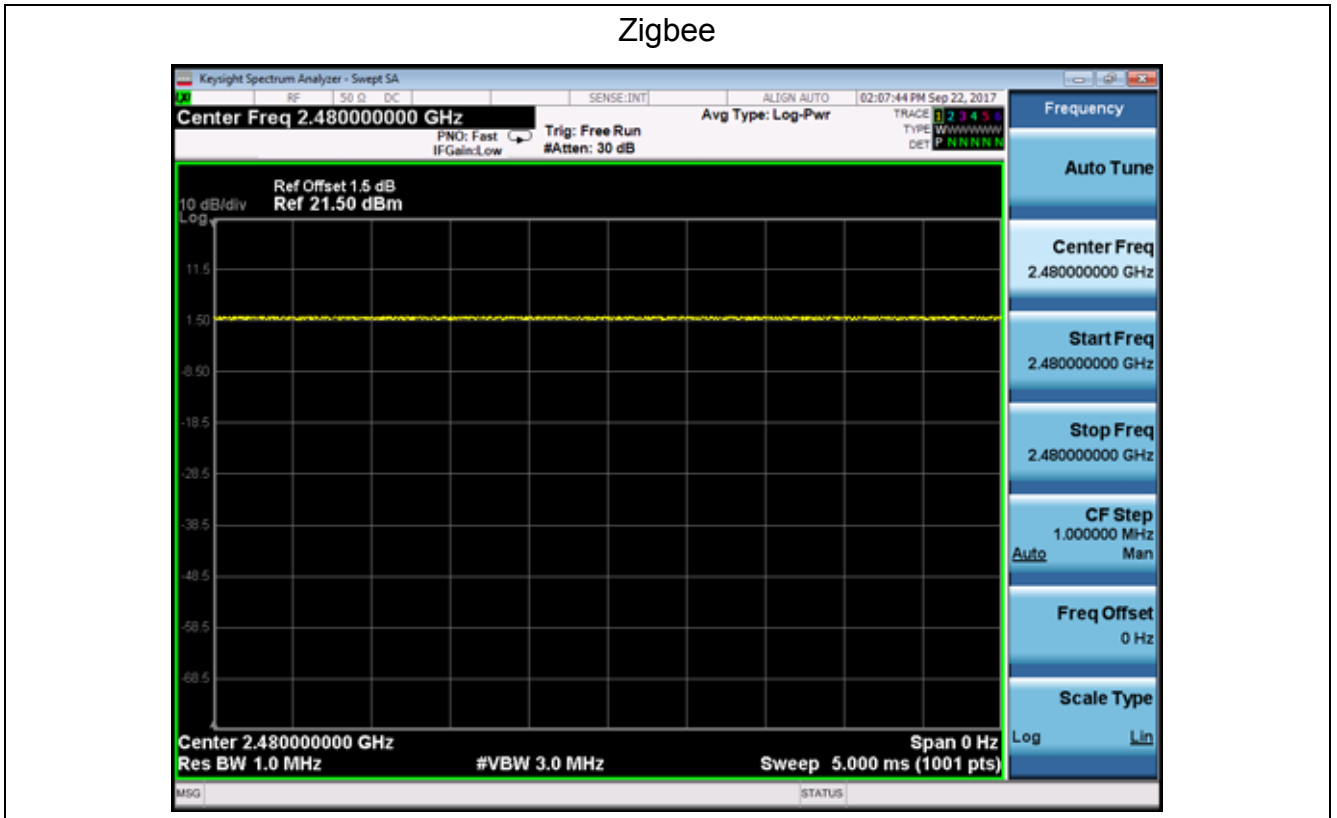

6.7 Test Result

The result for APT+Alvis+Diodes:

Site: AC5	Time: 2017/10/11 - 10:38
Limit: FCC_Part15.209_RE(3m)	Margin: 0
Probe: Horn_3117_00167055(1-18GHz)	Polarity: Horizontal
EUT: LED lamp	Power: AC 120V/60Hz
Note: Mode 1:Transmit at 2405MHz by zigbee	

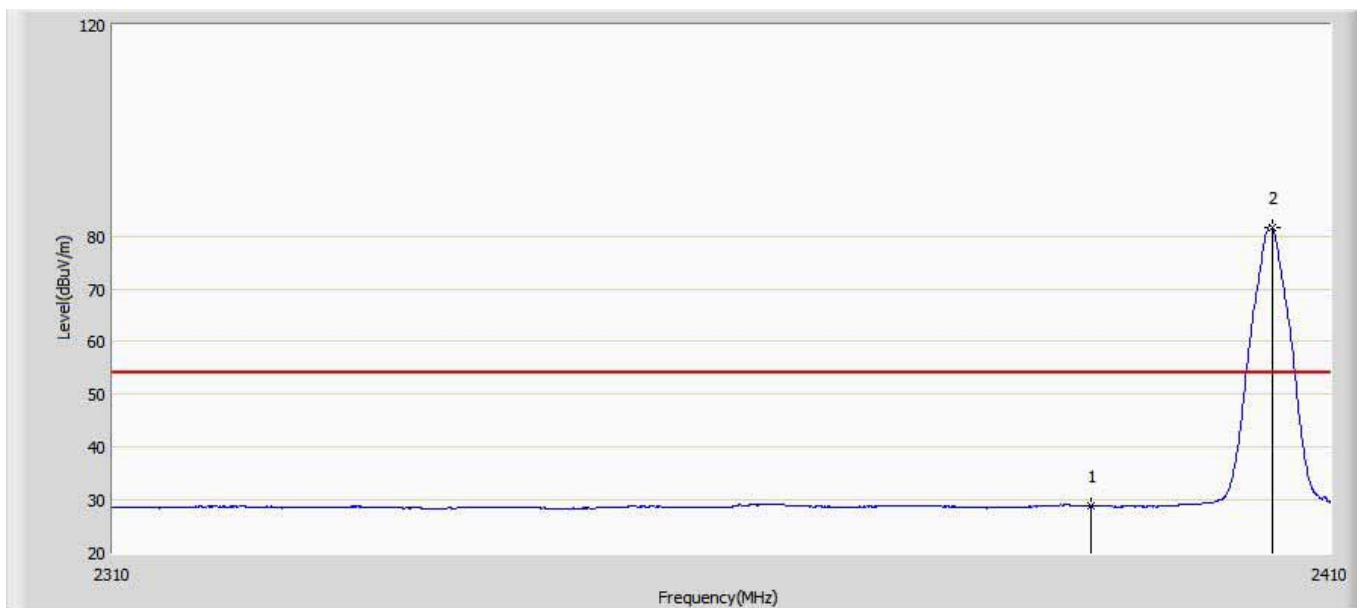

No	Mark	Frequency (MHz)	Measure Level (dBuV/m)	Reading Level (dBuV)	Over Limit (dB)	Limit (dBuV/m)	Factor (dB)	Type
1		2390.000	28.972	-0.076	-25.028	54.000	29.048	AV
2	*	2405.150	81.744	52.818	N/A	N/A	28.926	AV

Site: AC5	Time: 2017/10/11 - 10:52
Limit: FCC_Part15.209_RE(3m)	Margin: 0
Probe: Horn_3117_00167055(1-18GHz)	Polarity: Horizontal
EUT: LED lamp	Power: AC 120V/60Hz
Note: Mode 1:Transmit at 2405MHz by zigbee	

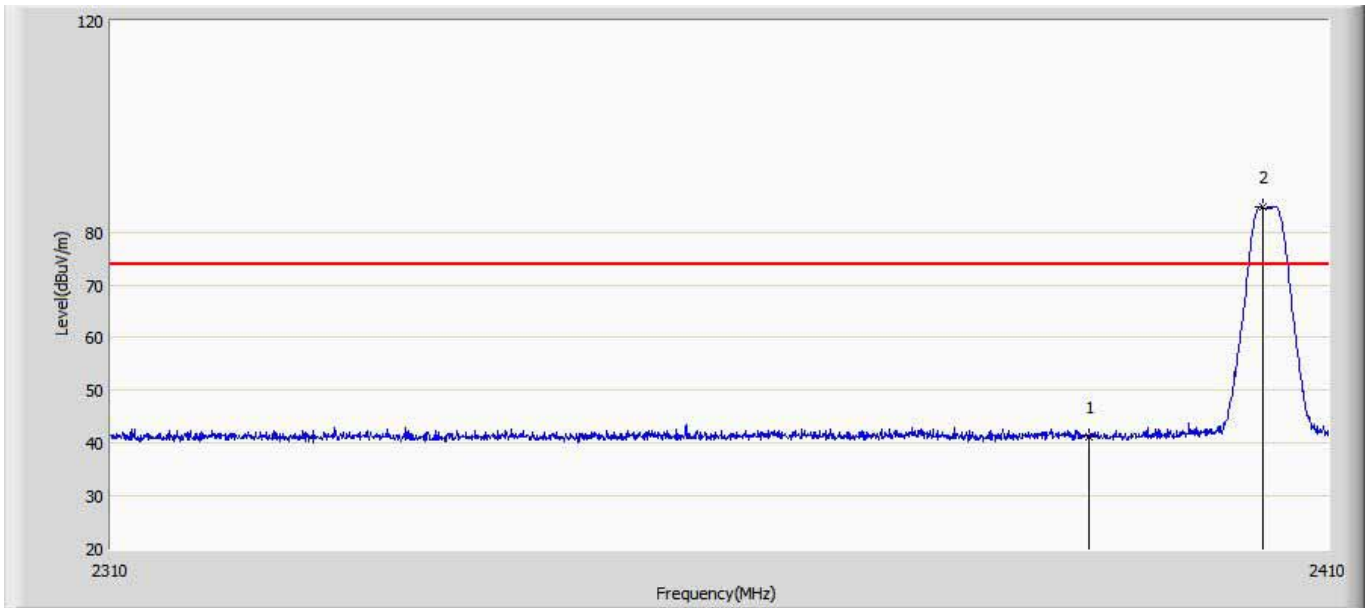

No	Mark	Frequency (MHz)	Measure Level (dBuV/m)	Reading Level (dBuV)	Over Limit (dB)	Limit (dBuV/m)	Factor (dB)	Type
1		2390.000	41.082	12.034	-32.918	74.000	29.048	PK
2	*	2404.500	84.817	55.884	N/A	N/A	28.933	PK

Site: AC5	Time: 2017/10/11 - 10:55
Limit: FCC_Part15.209_RE(3m)	Margin: 0
Probe: Horn_3117_00167055(1-18GHz)	Polarity: Vertical
EUT: LED lamp	Power: AC 120V/60Hz
Note: Mode 1:Transmit at 2405MHz by zigbee	

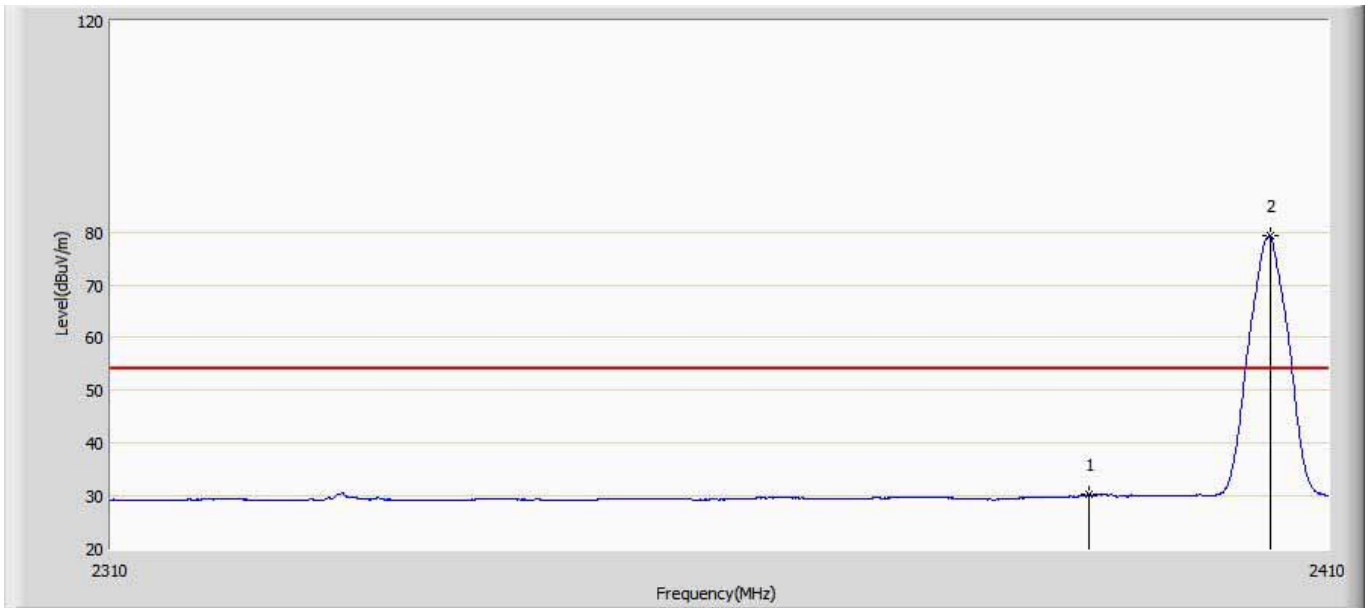

No	Mark	Frequency (MHz)	Measure Level (dBuV/m)	Reading Level (dBuV)	Over Limit (dB)	Limit (dBuV/m)	Factor (dB)	Type
1		2390.000	30.216	1.168	-23.784	54.000	29.048	AV
2	*	2405.150	79.189	50.263	N/A	N/A	28.926	AV

Site: AC5	Time: 2017/10/11 - 11:00
Limit: FCC_Part15.209_RE(3m)	Margin: 0
Probe: Horn_3117_00167055(1-18GHz)	Polarity: Vertical
EUT: LED lamp	Power: AC 120V/60Hz
Note: Mode 1:Transmit at 2405MHz by zigbee	

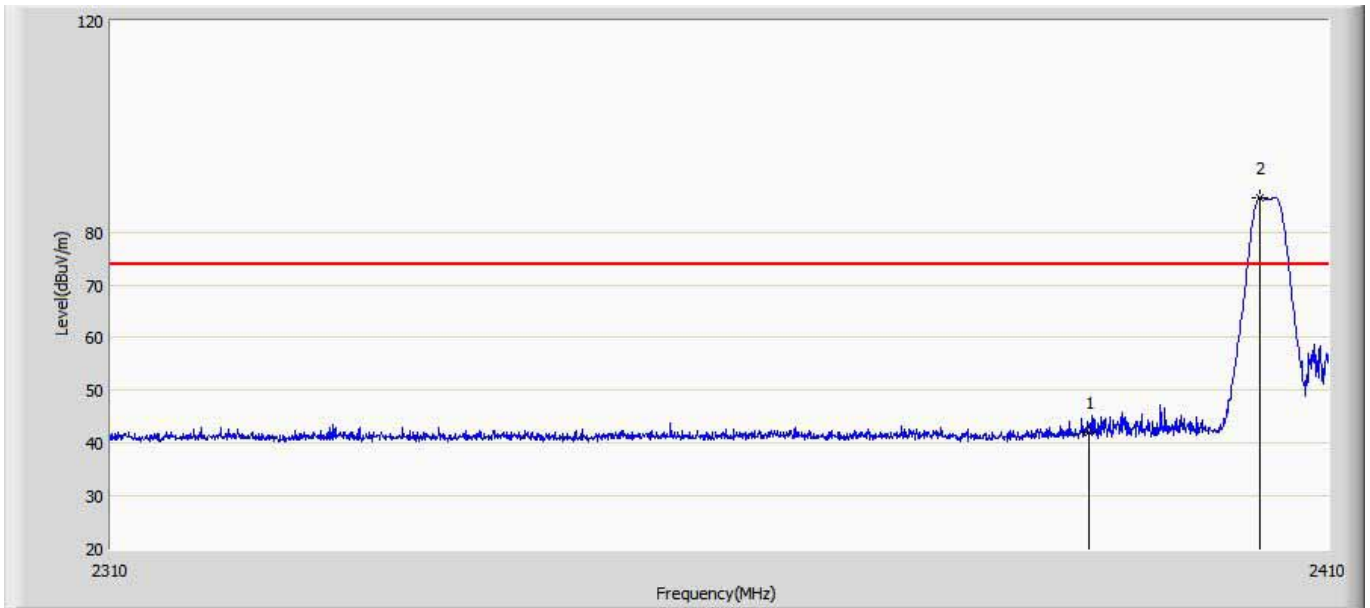

No	Mark	Frequency (MHz)	Measure Level (dBuV/m)	Reading Level (dBuV)	Over Limit (dB)	Limit (dBuV/m)	Factor (dB)	Type
1		2390.000	42.061	13.013	-31.939	74.000	29.048	PK
2	*	2404.350	86.566	57.631	N/A	N/A	28.935	PK

Site: AC5	Time: 2017/10/12 - 20:27
Limit: FCC_Part15.209_RE(3m)	Margin: 0
Probe: Horn_3117_00167055(1-18GHz)	Polarity: Horizontal
EUT: LED lamp	Power: AC 120V/60Hz
Note: Mode 1:Transmit at 2450MHz by zigbee	

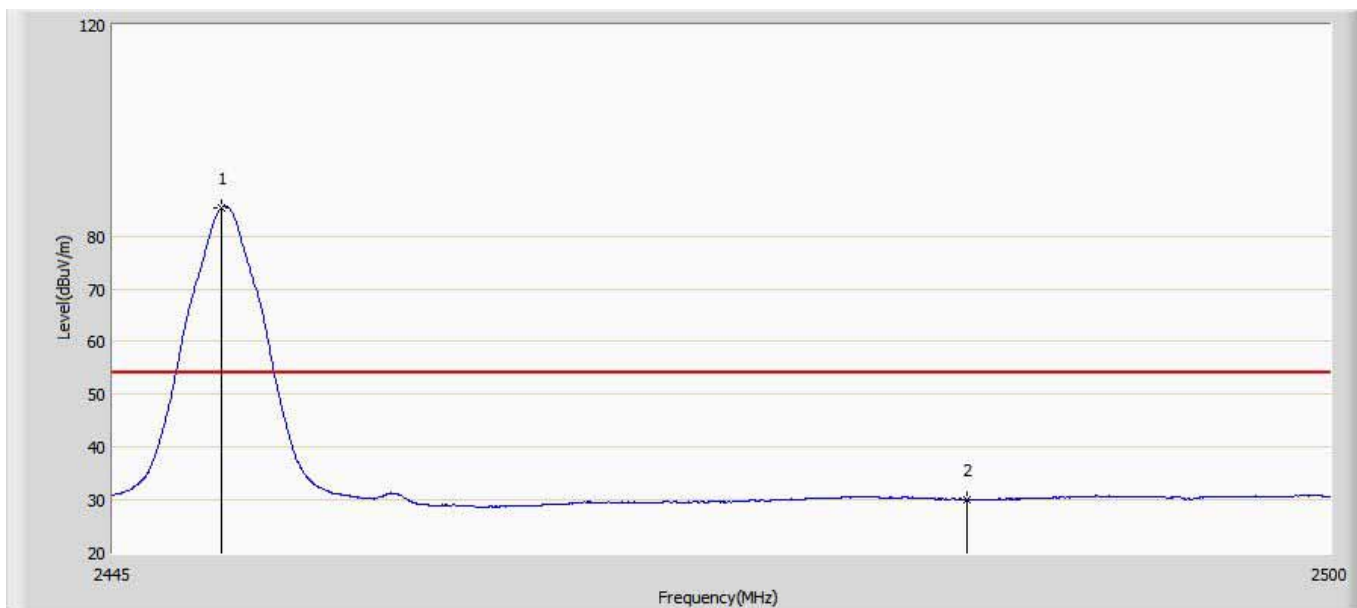

No	Mark	Frequency (MHz)	Measure Level (dBuV/m)	Reading Level (dBuV)	Over Limit (dB)	Limit (dBuV/m)	Factor (dB)	Type
1	*	2449.895	85.464	56.506	N/A	N/A	28.958	AV
2		2483.500	30.108	-0.376	-23.892	54.000	30.484	AV

Site: AC5	Time: 2017/10/12 - 20:42
Limit: FCC_Part15.209_RE(3m)	Margin: 0
Probe: Horn_3117_00167055(1-18GHz)	Polarity: Horizontal
EUT: LED lamp	Power: AC 120V/60Hz
Note: Mode 1:Transmit at 2450MHz by zigbee	

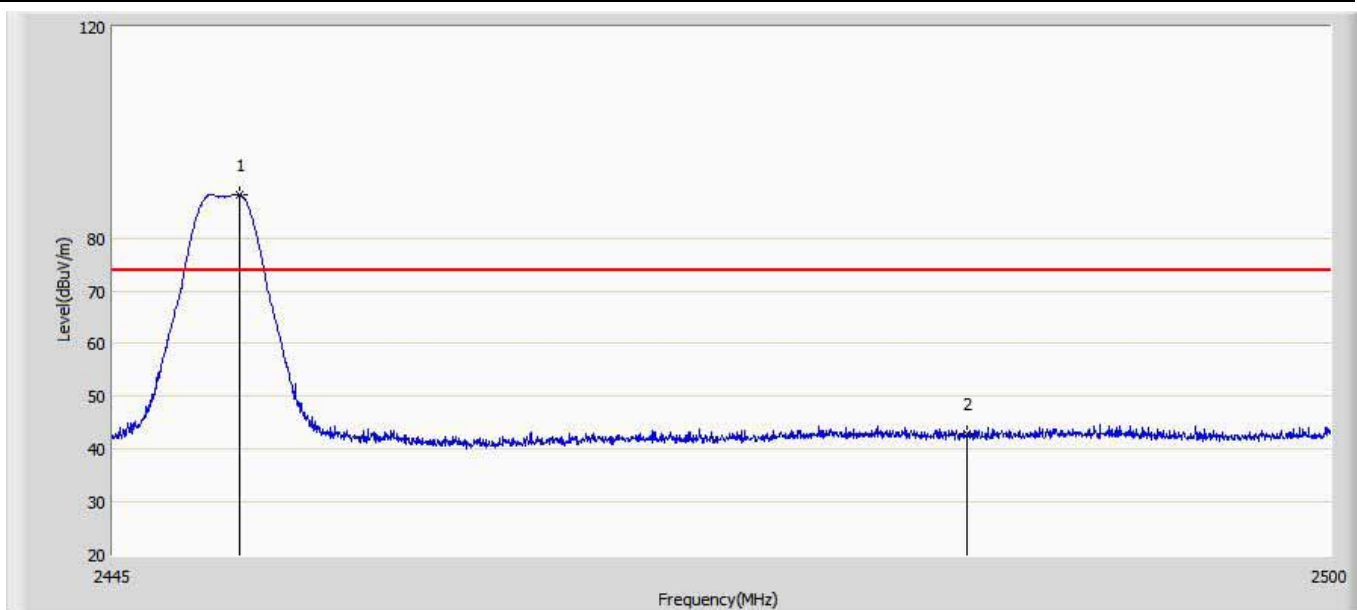

No	Mark	Frequency (MHz)	Measure Level (dBuV/m)	Reading Level (dBuV)	Over Limit (dB)	Limit (dBuV/m)	Factor (dB)	Type
1	*	2450.692	88.249	59.285	N/A	N/A	28.964	PK
2		2483.500	42.829	12.345	-31.171	74.000	30.484	PK

Site: AC5	Time: 2017/10/12 - 20:44
Limit: FCC_Part15.209_RE(3m)	Margin: 0
Probe: Horn_3117_00167055(1-18GHz)	Polarity: Vertical
EUT: LED lamp	Power: AC 120V/60Hz
Note: Mode 1:Transmit at 2450MHz by zigbee	

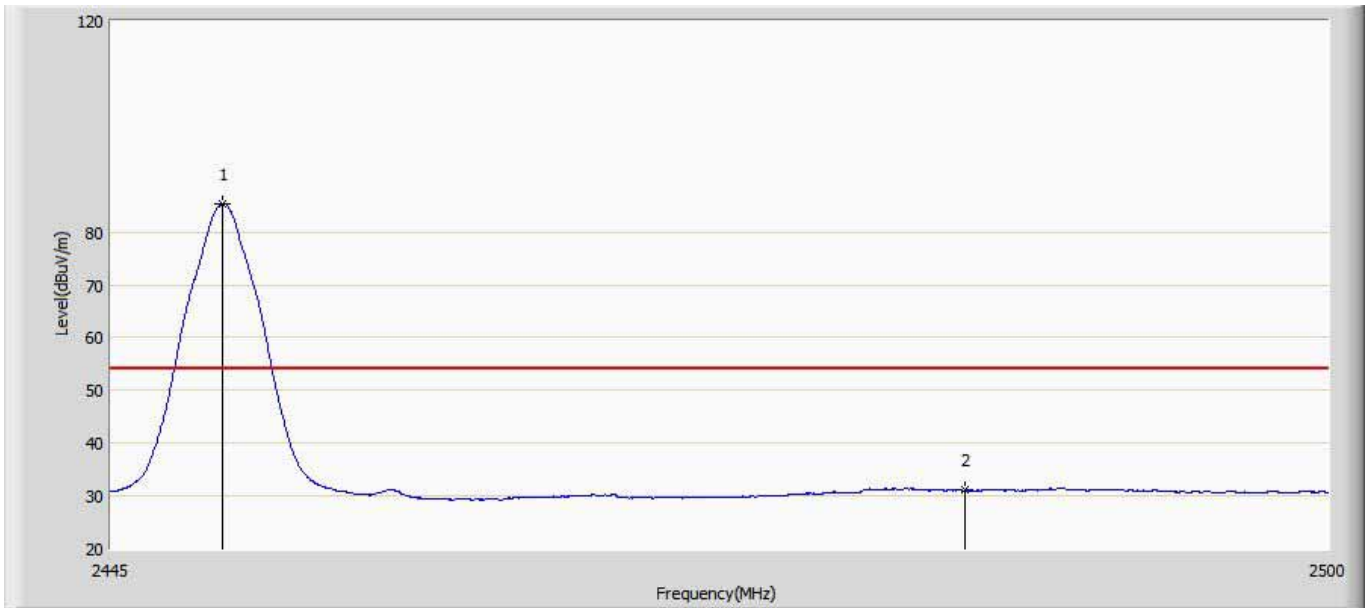

No	Mark	Frequency (MHz)	Measure Level (dBuV/m)	Reading Level (dBuV)	Over Limit (dB)	Limit (dBuV/m)	Factor (dB)	Type
1	*	2450.005	85.381	56.422	N/A	N/A	28.959	AV
2		2483.500	31.058	0.574	-22.942	54.000	30.484	AV

Site: AC5	Time: 2017/10/12 - 20:45
Limit: FCC_Part15.209_RE(3m)	Margin: 0
Probe: Horn_3117_00167055(1-18GHz)	Polarity: Vertical
EUT: LED lamp	Power: AC 120V/60Hz
Note: Mode 1:Transmit at 2450MHz by zigbee	

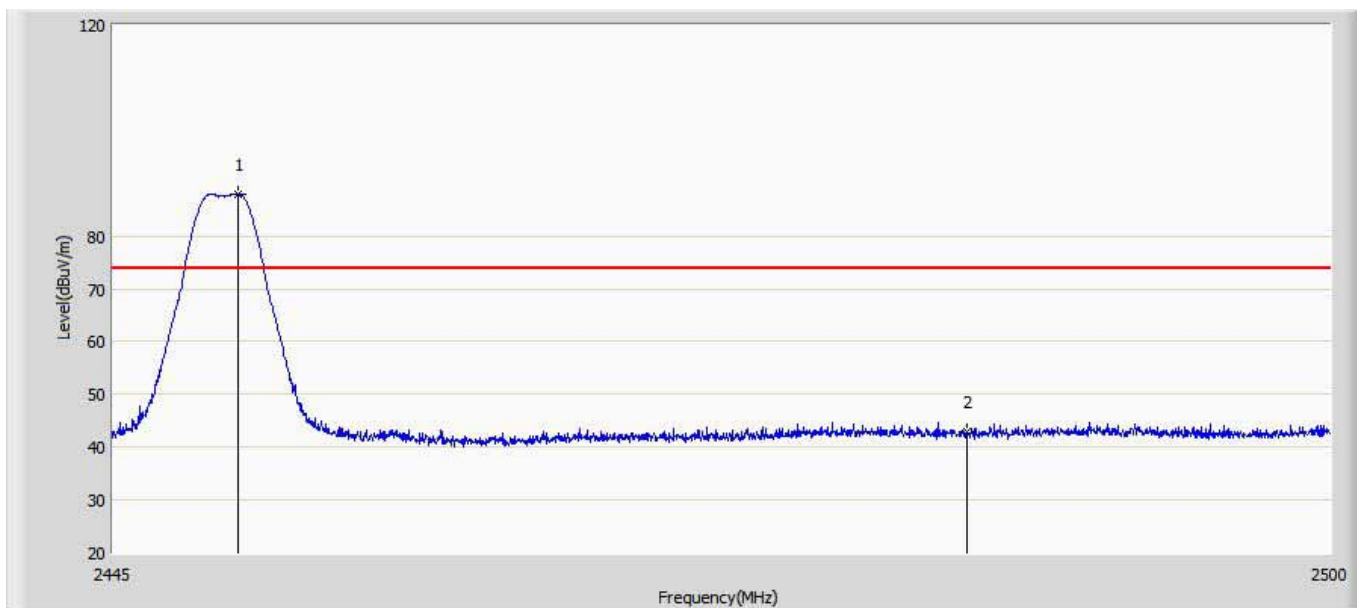

No	Mark	Frequency (MHz)	Measure Level (dBuV/m)	Reading Level (dBuV)	Over Limit (dB)	Limit (dBuV/m)	Factor (dB)	Type
1	*	2450.583	87.991	59.028	N/A	N/A	28.963	PK
2		2483.500	42.937	12.453	-31.062	74.000	30.484	PK

Site: AC5	Time: 2017/10/12 - 20:55
Limit: FCC_Part15.209_RE(3m)	Margin: 0
Probe: Horn_3117_00167055(1-18GHz)	Polarity: Horizontal
EUT: LED lamp	Power: AC 120V/60Hz
Note: Mode 1:Transmit at 2480MHz by zigbee	

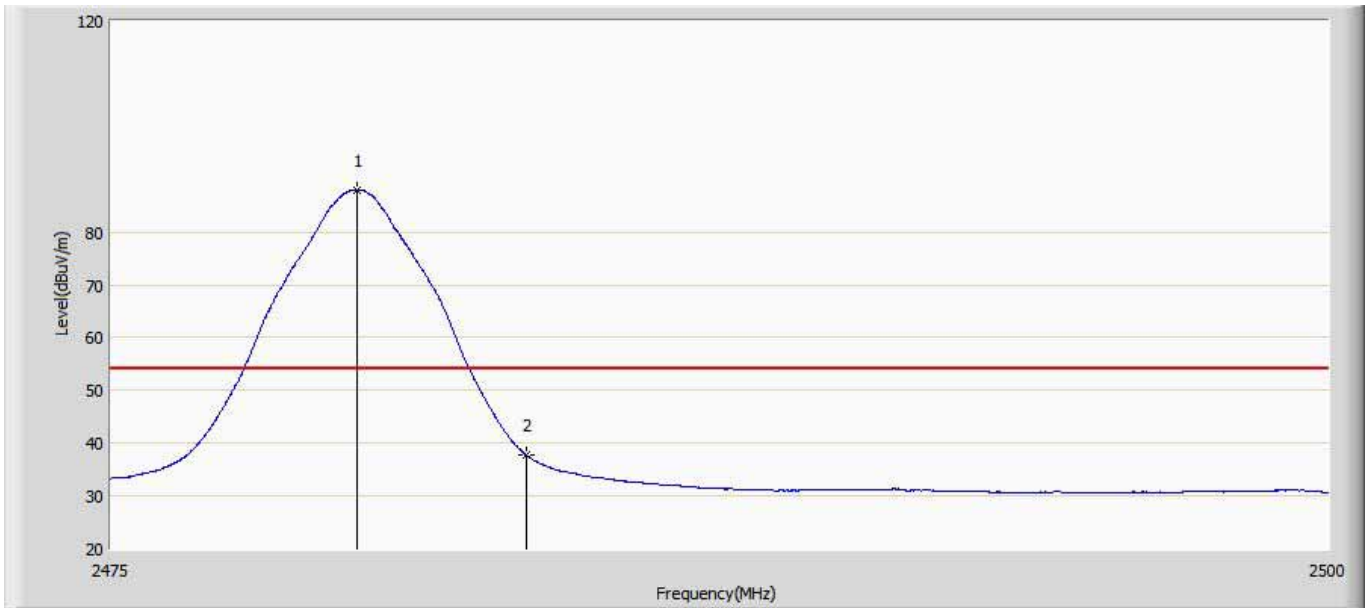

No	Mark	Frequency (MHz)	Measure Level (dBuV/m)	Reading Level (dBuV)	Over Limit (dB)	Limit (dBuV/m)	Factor (dB)	Type
1	*	2480.050	88.030	57.514	N/A	N/A	30.516	AV
2		2483.500	37.781	7.297	-16.219	54.000	30.484	AV

Site: AC5	Time: 2017/10/12 - 20:57
Limit: FCC_Part15.209_RE(3m)	Margin: 0
Probe: Horn_3117_00167055(1-18GHz)	Polarity: Horizontal
EUT: LED lamp	Power: AC 120V/60Hz
Note: Mode 1:Transmit at 2480MHz by zigbee	

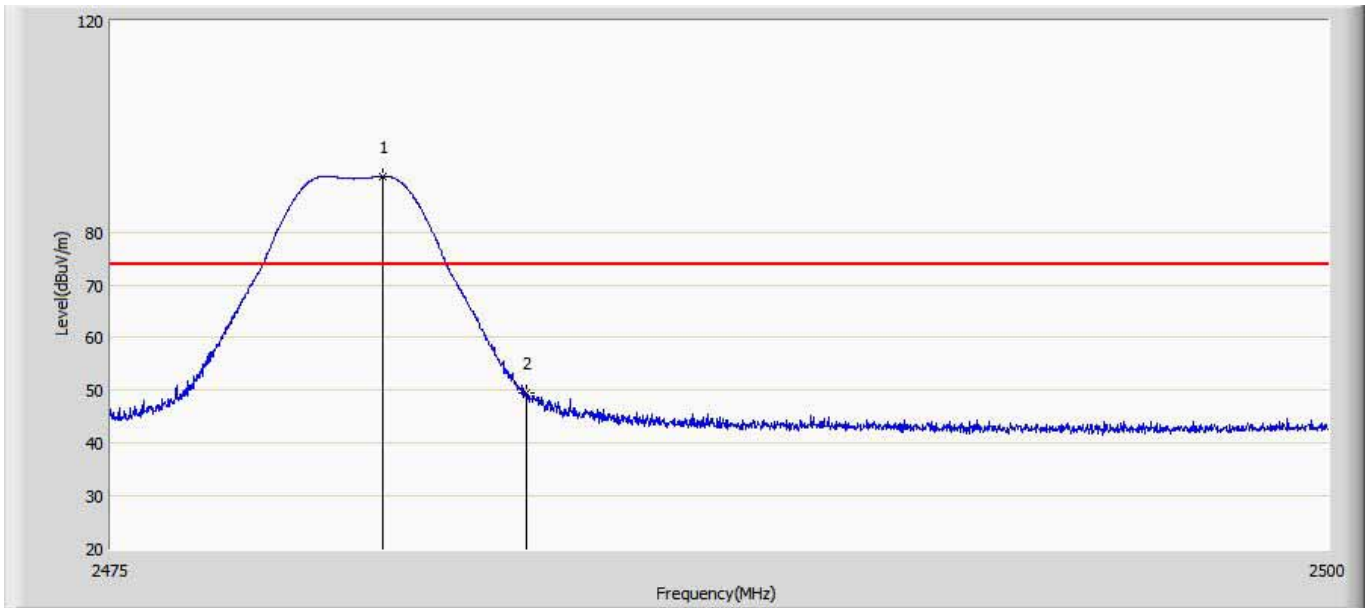

No	Mark	Frequency (MHz)	Measure Level (dBuV/m)	Reading Level (dBuV)	Over Limit (dB)	Limit (dBuV/m)	Factor (dB)	Type
1	*	2480.562	90.571	60.060	N/A	N/A	30.511	PK
2		2483.500	49.603	19.119	-24.397	74.000	30.484	PK

Site: AC5	Time: 2017/10/12 - 20:58
Limit: FCC_Part15.209_RE(3m)	Margin: 0
Probe: Horn_3117_00167055(1-18GHz)	Polarity: Vertical
EUT: LED lamp	Power: AC 120V/60Hz
Note: Mode 1:Transmit at 2480MHz by zigbee	

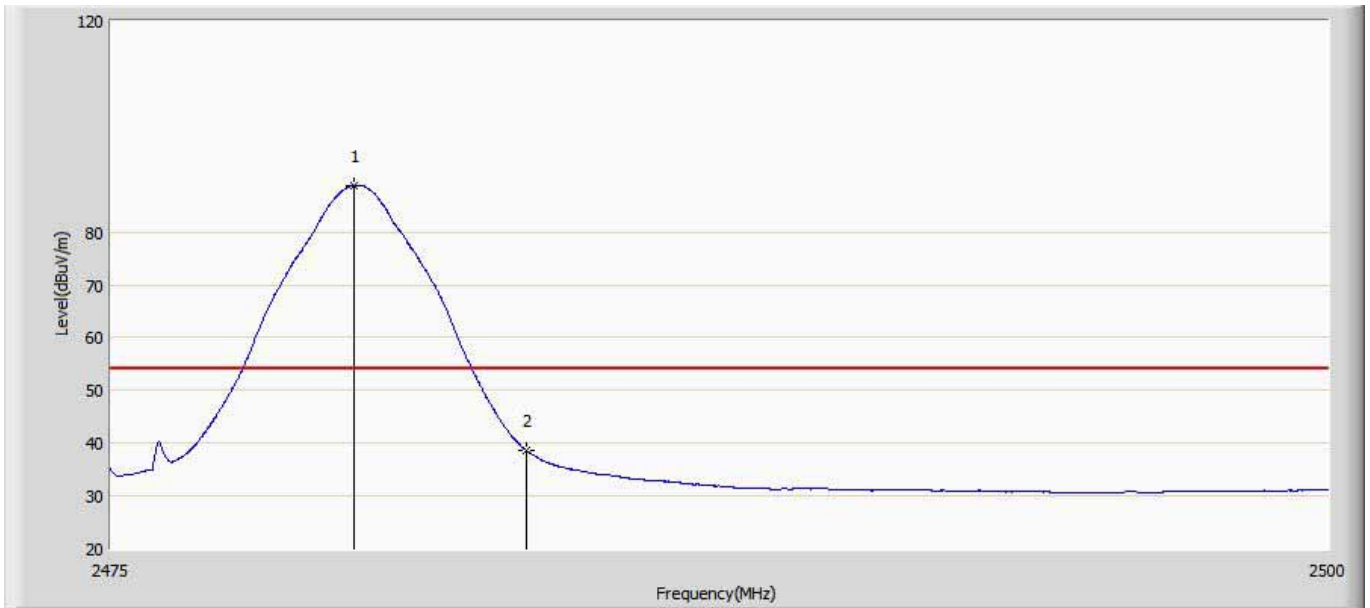

No	Mark	Frequency (MHz)	Measure Level (dBuV/m)	Reading Level (dBuV)	Over Limit (dB)	Limit (dBuV/m)	Factor (dB)	Type
1	*	2479.975	88.815	58.299	N/A	N/A	30.516	AV
2		2483.500	38.741	8.257	-15.259	54.000	30.484	AV

Site: AC5	Time: 2017/10/12 - 21:00
Limit: FCC_Part15.209_RE(3m)	Margin: 0
Probe: Horn_3117_00167055(1-18GHz)	Polarity: Vertical
EUT: LED lamp	Power: AC 120V/60Hz
Note: Mode 1:Transmit at 2480MHz by zigbee	

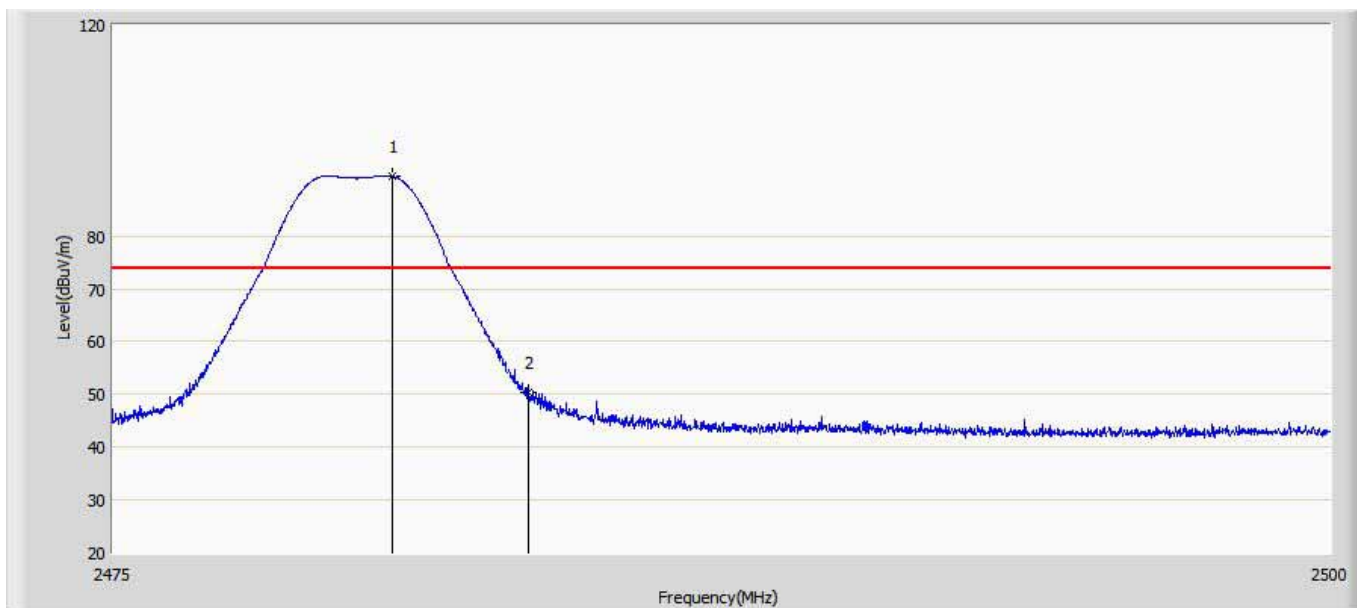

No	Mark	Frequency (MHz)	Measure Level (dBuV/m)	Reading Level (dBuV)	Over Limit (dB)	Limit (dBuV/m)	Factor (dB)	Type
1	*	2480.712	91.362	60.852	N/A	N/A	30.510	PK
2		2483.500	50.281	19.797	-23.719	74.000	30.484	PK

The result for LTN+Alvis+Diodes:

Site: AC5	Time: 2017/09/23 - 16:27
Limit: FCC_Part15.209_RE(3m)	Margin: 0
Probe: Horn_3117_00167055(1-18GHz)	Polarity: Horizontal
EUT: LED lamp	Power: AC 120V/60Hz
Note: Mode 1:Transmit at 2405MHz by zigbee	

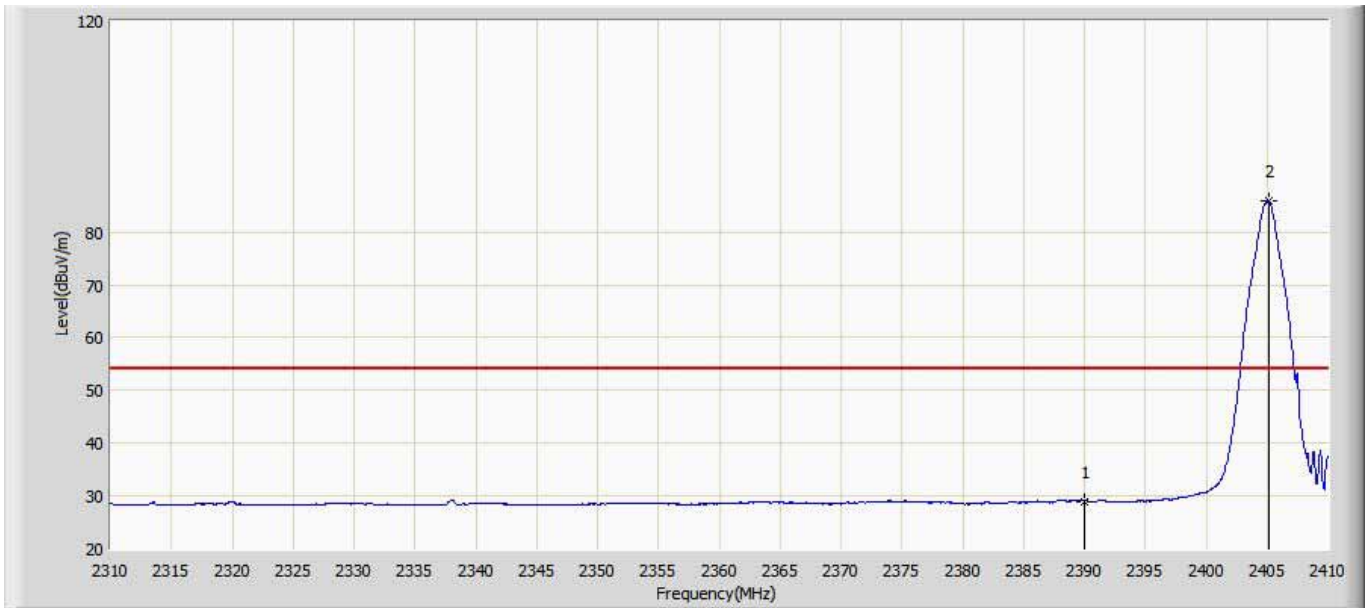

No	Mark	Frequency (MHz)	Measure Level (dBuV/m)	Reading Level (dBuV)	Over Limit (dB)	Limit (dBuV/m)	Factor (dB)	Type
1		2390.000	29.013	-0.035	-24.987	54.000	29.048	AV
2	*	2405.100	85.806	56.879	N/A	N/A	28.927	AV

Site: AC5	Time: 2017/09/23 - 16:32
Limit: FCC_Part15.209_RE(3m)	Margin: 0
Probe: Horn_3117_00167055(1-18GHz)	Polarity: Horizontal
EUT: LED lamp	Power: AC 120V/60Hz
Note: Mode 1:Transmit at 2405MHz by zigbee	

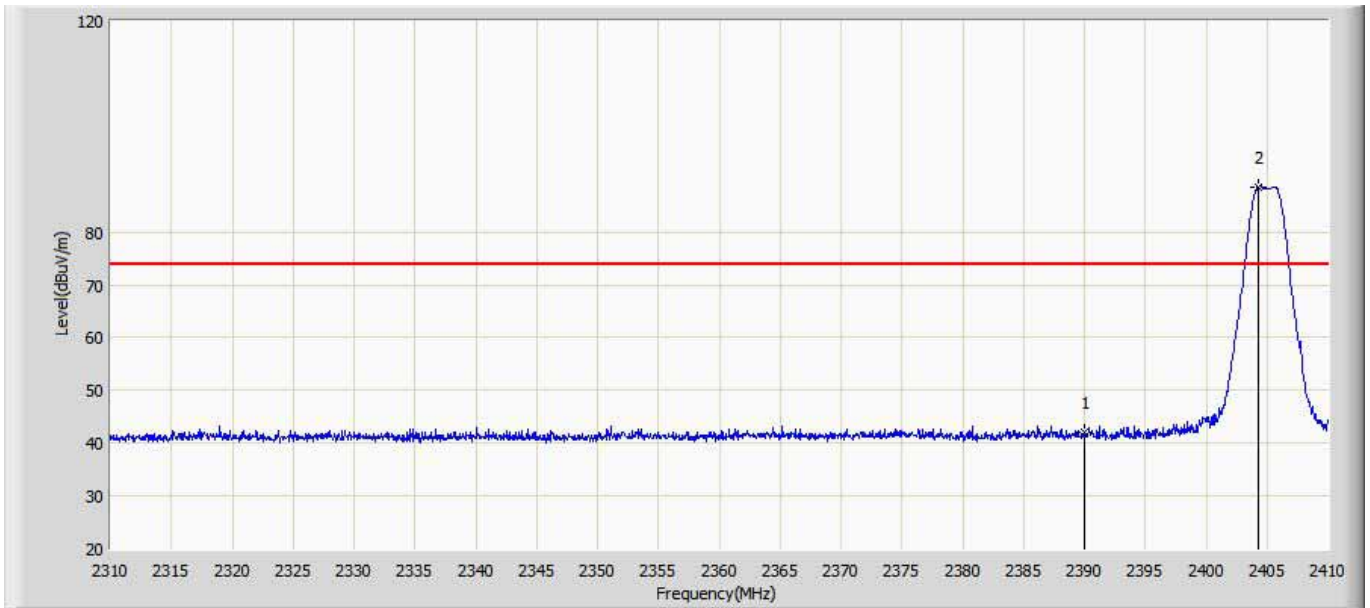

No	Mark	Frequency (MHz)	Measure Level (dBuV/m)	Reading Level (dBuV)	Over Limit (dB)	Limit (dBuV/m)	Factor (dB)	Type
1		2390.000	42.071	13.023	-31.929	74.000	29.048	PK
2	*	2404.250	88.547	59.611	N/A	N/A	28.936	PK

Site: AC5	Time: 2017/09/23 - 16:46
Limit: FCC_Part15.209_RE(3m)	Margin: 0
Probe: Horn_3117_00167055(1-18GHz)	Polarity: Vertical
EUT: LED lamp	Power: AC 120V/60Hz
Note: Mode 1:Transmit at 2405MHz by zigbee	

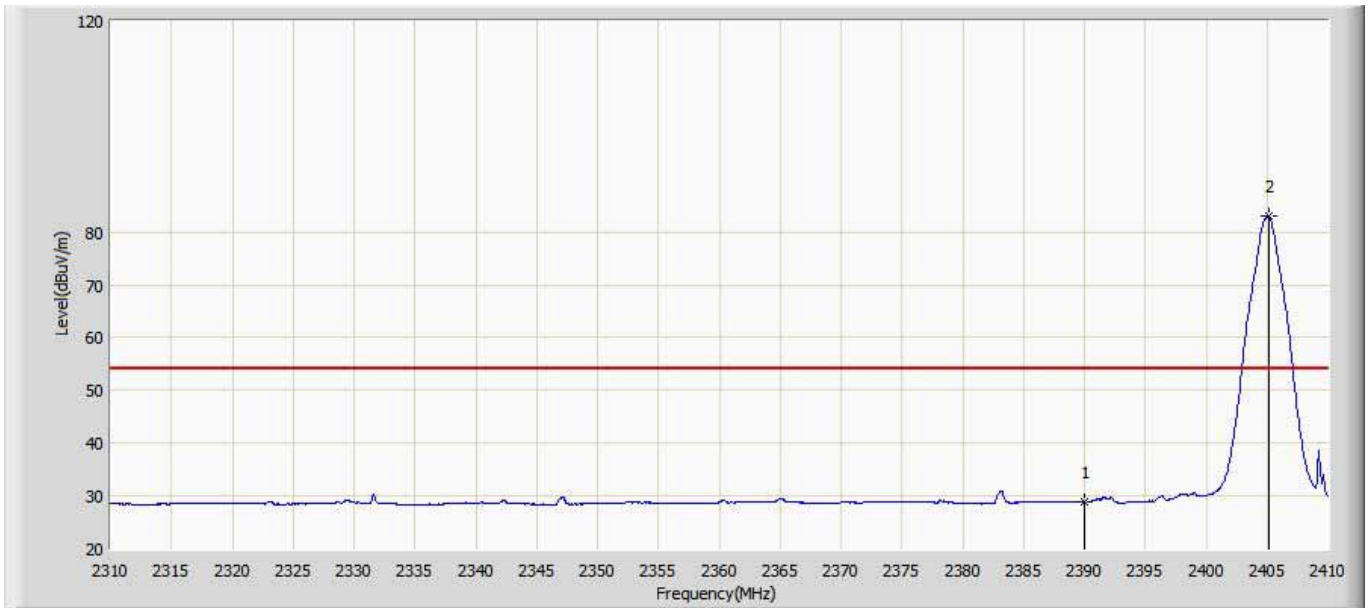

No	Mark	Frequency (MHz)	Measure Level (dBuV/m)	Reading Level (dBuV)	Over Limit (dB)	Limit (dBuV/m)	Factor (dB)	Type
1		2390.000	28.771	-0.277	-25.229	54.000	29.048	AV
2	*	2405.100	83.042	54.115	N/A	N/A	28.927	AV

Site: AC5	Time: 2017/09/23 - 16:49
Limit: FCC_Part15.209_RE(3m)	Margin: 0
Probe: Horn_3117_00167055(1-18GHz)	Polarity: Vertical
EUT: LED lamp	Power: AC 120V/60Hz
Note: Mode 1:Transmit at 2405MHz by zigbee	

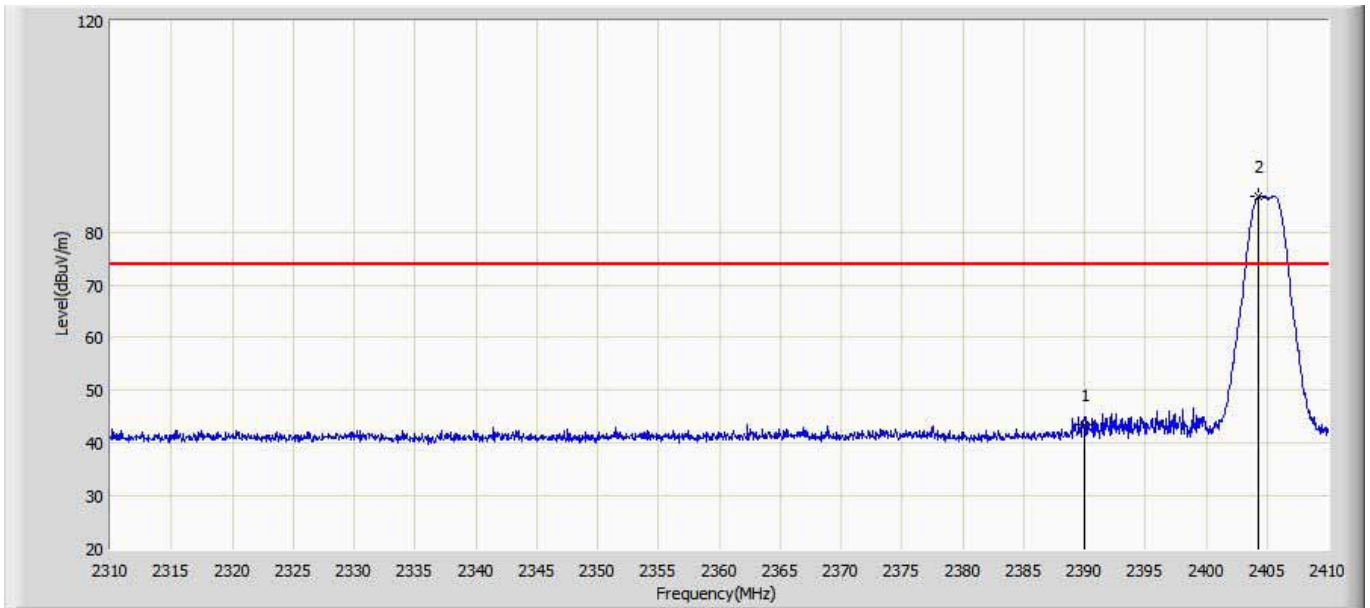

No	Mark	Frequency (MHz)	Measure Level (dBuV/m)	Reading Level (dBuV)	Over Limit (dB)	Limit (dBuV/m)	Factor (dB)	Type
1		2390.000	43.551	14.503	-30.449	74.000	29.048	PK
2	*	2404.250	86.660	57.724	N/A	N/A	28.936	PK

Site: AC5	Time: 2017/09/23 - 17:18
Limit: FCC_Part15.209_RE(3m)	Margin: 0
Probe: Horn_3117_00167055(1-18GHz)	Polarity: Horizontal
EUT: LED lamp	Power: AC 120V/60Hz
Note: Mode 1:Transmit at 2450MHz by zigbee	

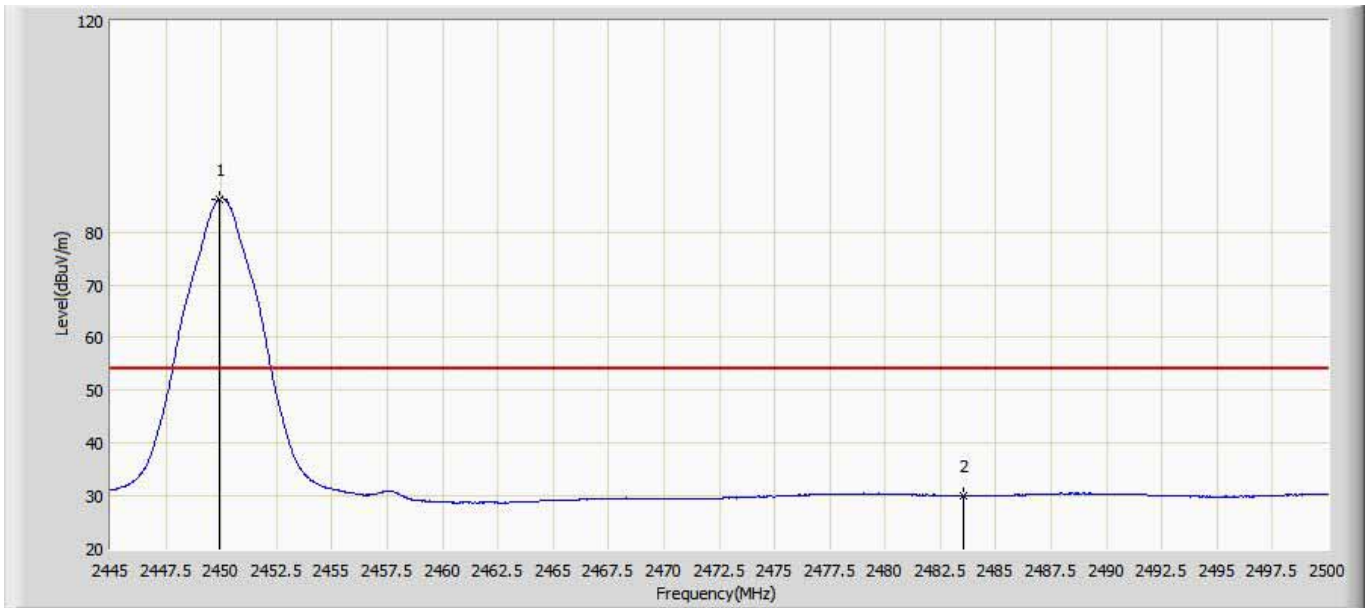

No	Mark	Frequency (MHz)	Measure Level (dBuV/m)	Reading Level (dBuV)	Over Limit (dB)	Limit (dBuV/m)	Factor (dB)	Type
1	*	2449.950	86.315	57.357	N/A	N/A	28.958	AV
2		2483.500	30.020	-0.464	-23.980	54.000	30.484	AV

Site: AC5	Time: 2017/09/23 - 17:30
Limit: FCC_Part15.209_RE(3m)	Margin: 0
Probe: Horn_3117_00167055(1-18GHz)	Polarity: Horizontal
EUT: LED lamp	Power: AC 120V/60Hz
Note: Mode 1:Transmit at 2450MHz by zigbee	

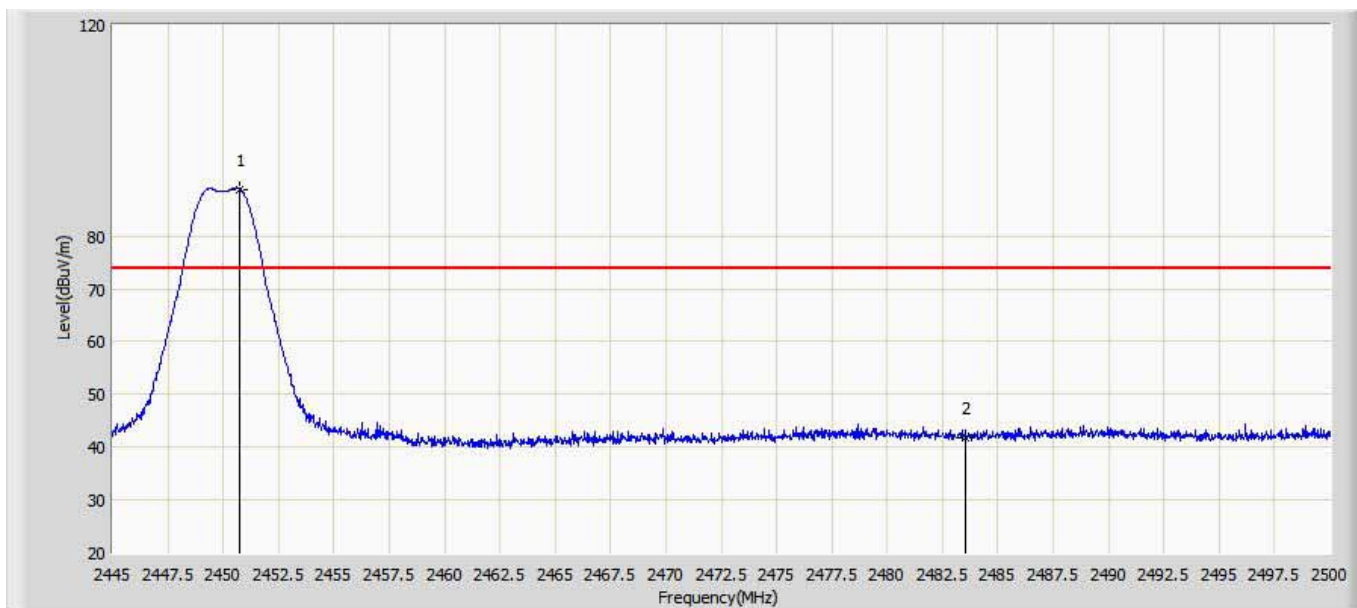

No	Mark	Frequency (MHz)	Measure Level (dBuV/m)	Reading Level (dBuV)	Over Limit (dB)	Limit (dBuV/m)	Factor (dB)	Type
1	*	2450.748	88.858	59.894	N/A	N/A	28.964	PK
2		2483.500	41.840	11.356	-32.160	74.000	30.484	PK

Site: AC5	Time: 2017/09/23 - 17:37
Limit: FCC_Part15.209_RE(3m)	Margin: 0
Probe: Horn_3117_00167055(1-18GHz)	Polarity: Vertical
EUT: LED lamp	Power: AC 120V/60Hz
Note: Mode 1:Transmit at 2450MHz by zigbee	

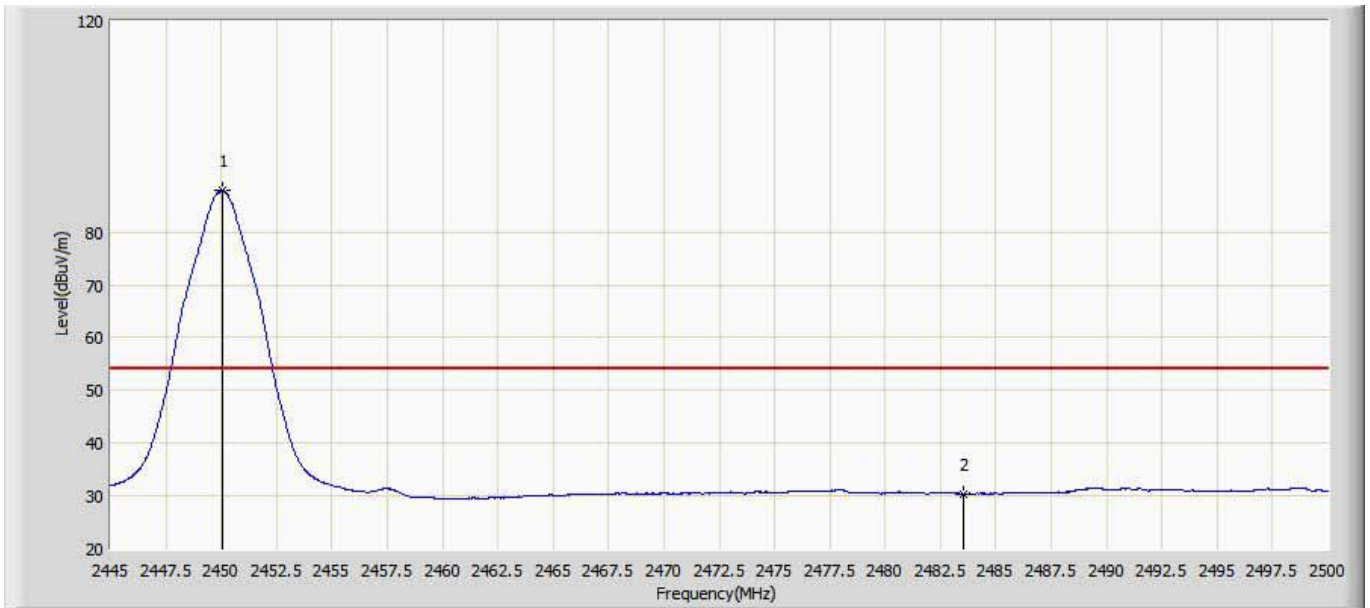

No	Mark	Frequency (MHz)	Measure Level (dBuV/m)	Reading Level (dBuV)	Over Limit (dB)	Limit (dBuV/m)	Factor (dB)	Type
1	*	2450.060	87.877	58.918	N/A	N/A	28.959	AV
2		2483.500	30.300	-0.184	-23.700	54.000	30.484	AV

Site: AC5	Time: 2017/09/23 - 17:42
Limit: FCC_Part15.209_RE(3m)	Margin: 0
Probe: Horn_3117_00167055(1-18GHz)	Polarity: Vertical
EUT: LED lamp	Power: AC 120V/60Hz
Note: Mode 1:Transmit at 2450MHz by zigbee	

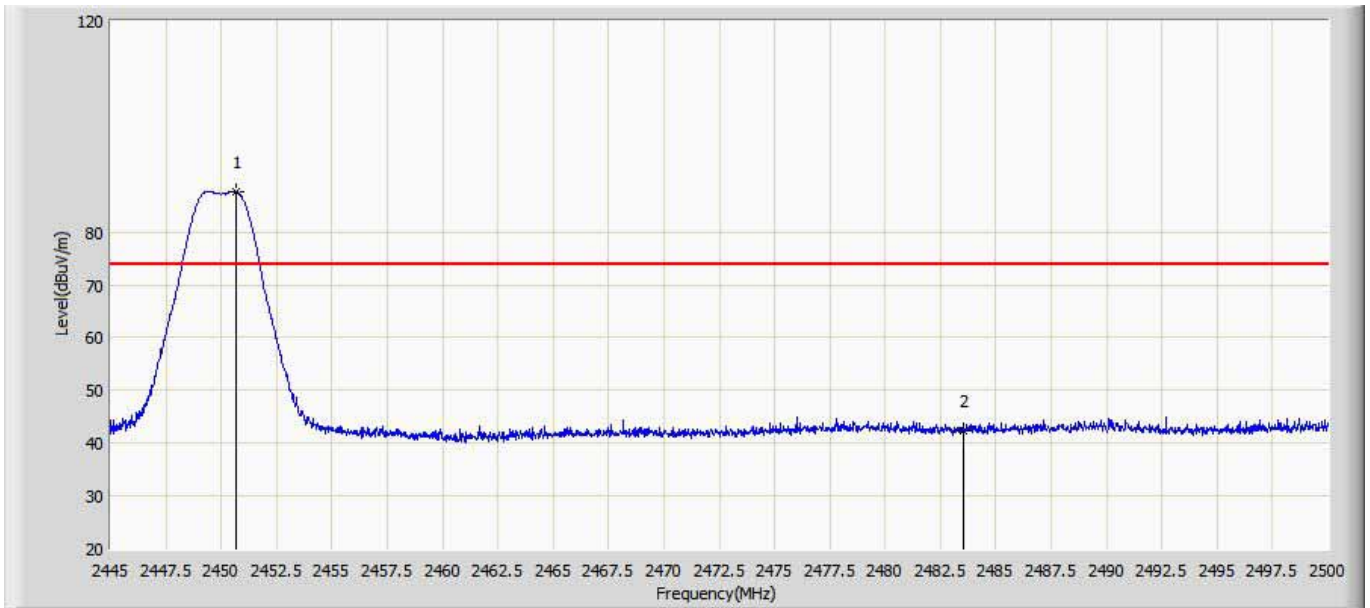

No	Mark	Frequency (MHz)	Measure Level (dBuV/m)	Reading Level (dBuV)	Over Limit (dB)	Limit (dBuV/m)	Factor (dB)	Type
1	*	2450.665	87.569	58.606	N/A	N/A	28.963	PK
2		2483.500	42.370	11.886	-31.630	74.000	30.484	PK

Site: AC5	Time: 2017/09/23 - 18:00
Limit: FCC_Part15.209_RE(3m)	Margin: 0
Probe: Horn_3117_00167055(1-18GHz)	Polarity: Horizontal
EUT: LED lamp	Power: AC 120V/60Hz
Note: Mode 1:Transmit at 2480MHz by zigbee	

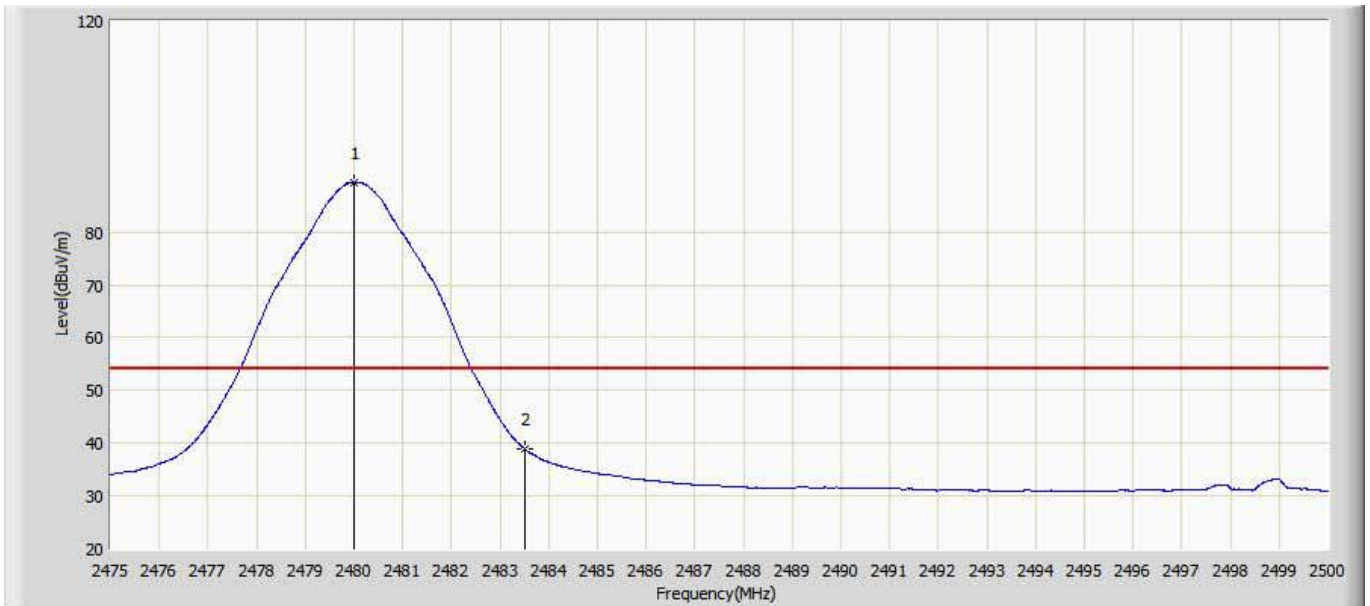

No	Mark	Frequency (MHz)	Measure Level (dBuV/m)	Reading Level (dBuV)	Over Limit (dB)	Limit (dBuV/m)	Factor (dB)	Type
1	*	2480.000	89.459	58.943	N/A	N/A	30.516	AV
2		2483.500	38.994	8.510	-15.006	54.000	30.484	AV

Site: AC5	Time: 2017/09/23 - 18:05
Limit: FCC_Part15.209_RE(3m)	Margin: 0
Probe: Horn_3117_00167055(1-18GHz)	Polarity: Horizontal
EUT: LED lamp	Power: AC 120V/60Hz
Note: Mode 1:Transmit at 2480MHz by zigbee	

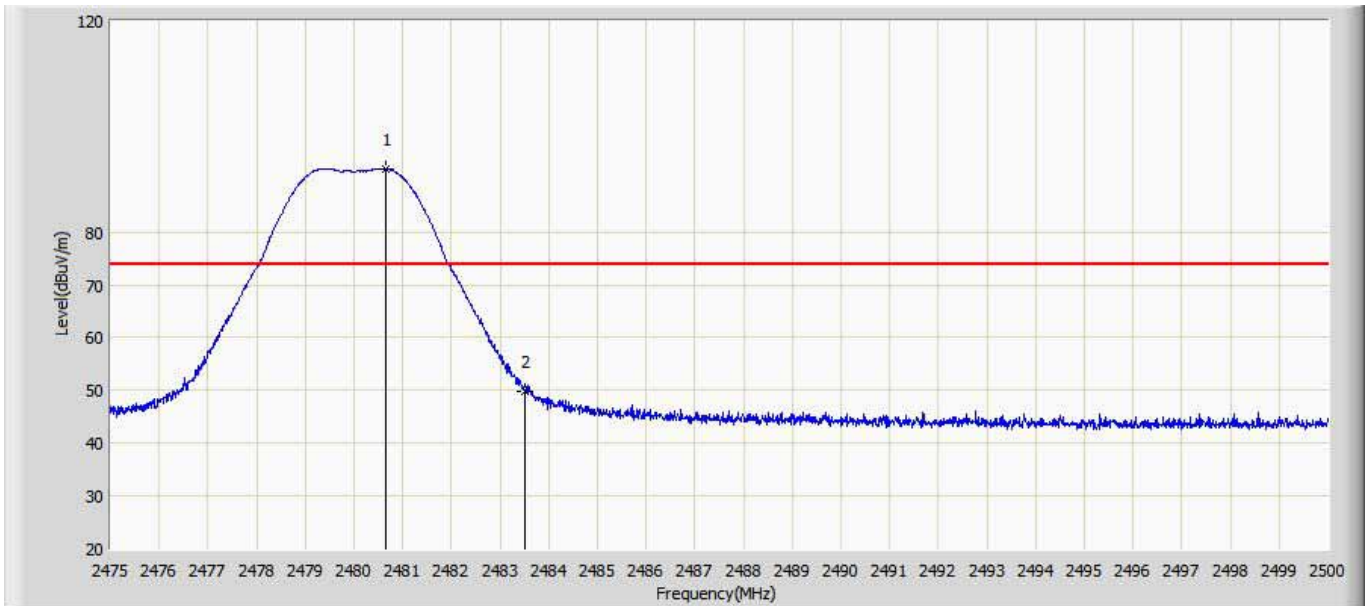

No	Mark	Frequency (MHz)	Measure Level (dBuV/m)	Reading Level (dBuV)	Over Limit (dB)	Limit (dBuV/m)	Factor (dB)	Type
1	*	2480.663	91.925	61.415	N/A	N/A	30.510	PK
2		2483.500	49.847	19.363	-24.153	74.000	30.484	PK

Site: AC5	Time: 2017/09/23 - 18:07
Limit: FCC_Part15.209_RE(3m)	Margin: 0
Probe: Horn_3117_00167055(1-18GHz)	Polarity: Vertical
EUT: LED lamp	Power: AC 120V/60Hz
Note: Mode 1:Transmit at 2480MHz by zigbee	

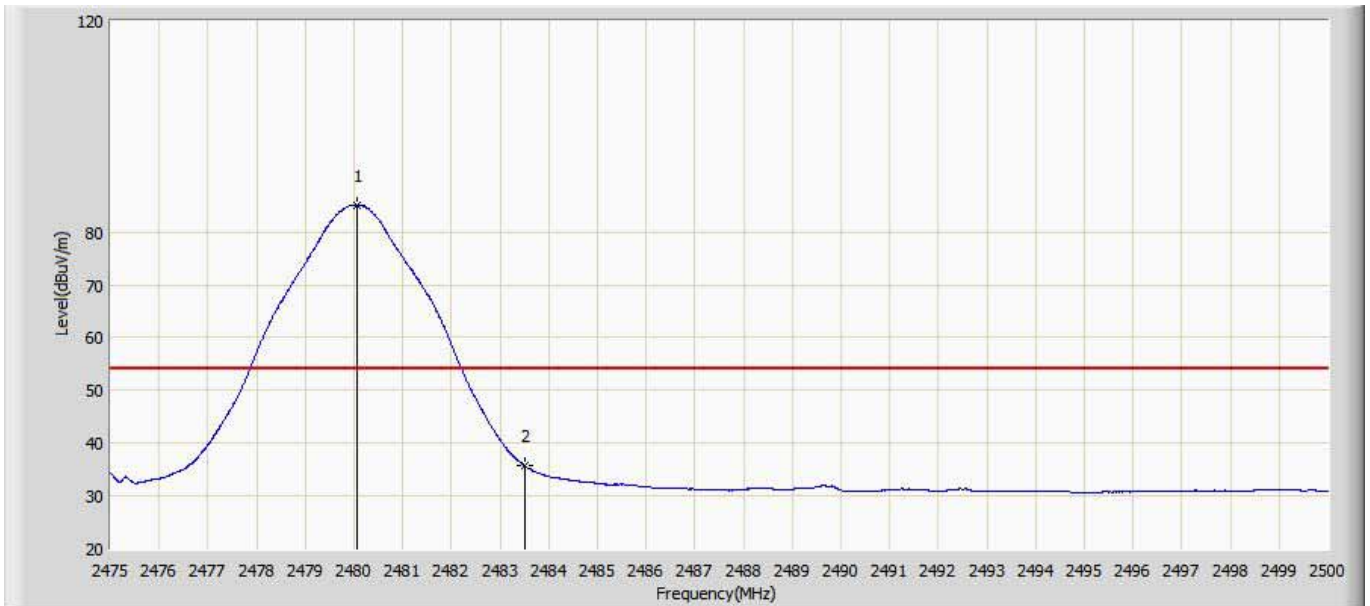

No	Mark	Frequency (MHz)	Measure Level (dBuV/m)	Reading Level (dBuV)	Over Limit (dB)	Limit (dBuV/m)	Factor (dB)	Type
1	*	2480.075	85.111	54.596	N/A	N/A	30.515	AV
2		2483.500	35.707	5.223	-18.293	54.000	30.484	AV

Site: AC5	Time: 2017/09/23 - 18:10
Limit: FCC_Part15.209_RE(3m)	Margin: 0
Probe: Horn_3117_00167055(1-18GHz)	Polarity: Vertical
EUT: LED lamp	Power: AC 120V/60Hz
Note: Mode 1:Transmit at 2480MHz by zigbee	

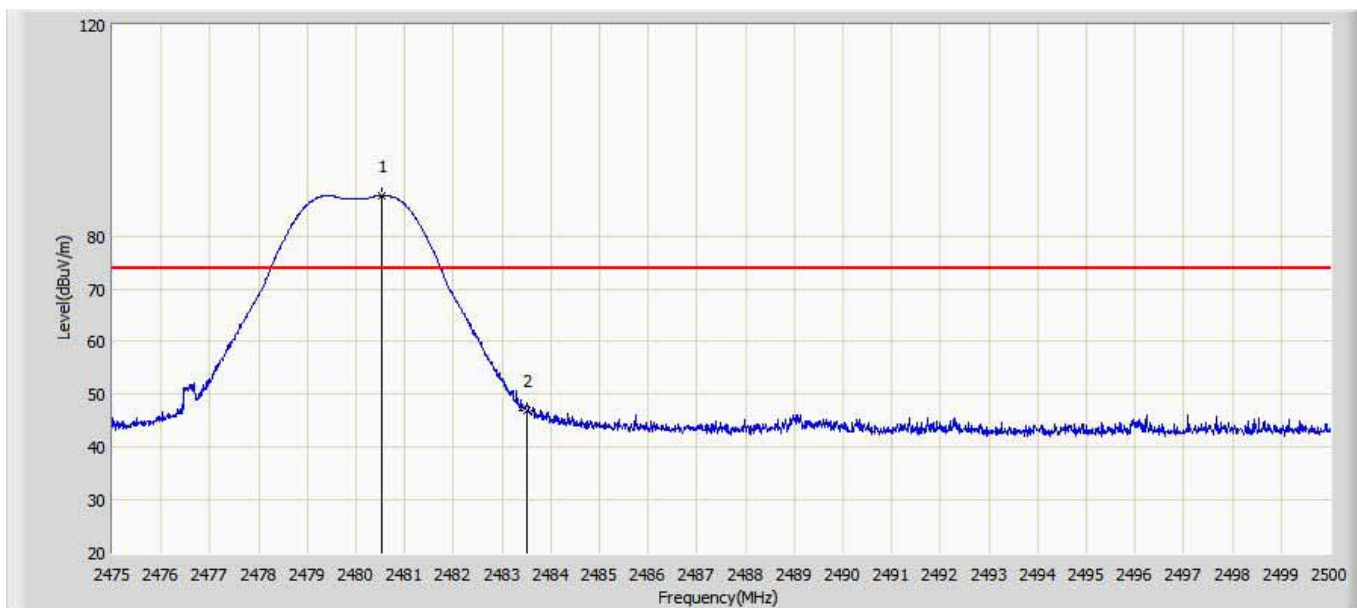

No	Mark	Frequency (MHz)	Measure Level (dBuV/m)	Reading Level (dBuV)	Over Limit (dB)	Limit (dBuV/m)	Factor (dB)	Type
1	*	2480.538	87.603	57.092	N/A	N/A	30.511	PK
2		2483.500	46.938	16.454	-27.062	74.000	30.484	PK

The result for APT+Alvis+Murata:

Site: AC5	Time: 2017/12/12 - 16:02
Limit: FCC_Part15.209_RE(3m)	Margin: 0
Probe: Horn_3117_00167055(1-18GHz)	Polarity: Horizontal
EUT: LED lamp	Power: AC 120V/60Hz
Note: Mode 1:Transmit at 2405MHz by zigbee	

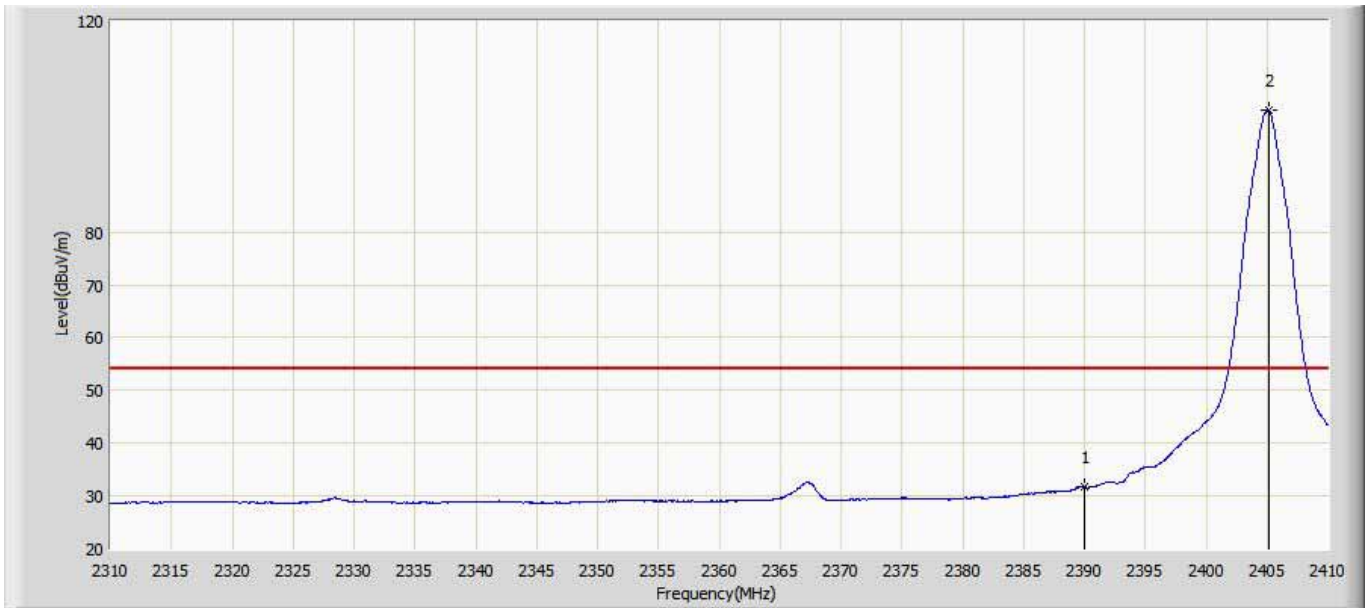

No	Mark	Frequency (MHz)	Measure Level (dBuV/m)	Reading Level (dBuV)	Over Limit (dB)	Limit (dBuV/m)	Factor (dB)	Type
1		2390.000	31.536	2.690	-22.464	54.000	30.510	AV
2	*	2405.100	102.886	74.064	N/A	N/A	30.484	AV

Site: AC5	Time: 2017/12/12 - 16:08
Limit: FCC_Part15.209_RE(3m)	Margin: 0
Probe: Horn_3117_00167055(1-18GHz)	Polarity: Horizontal
EUT: LED lamp	Power: AC 120V/60Hz
Note: Mode 1:Transmit at 2405MHz by zigbee	

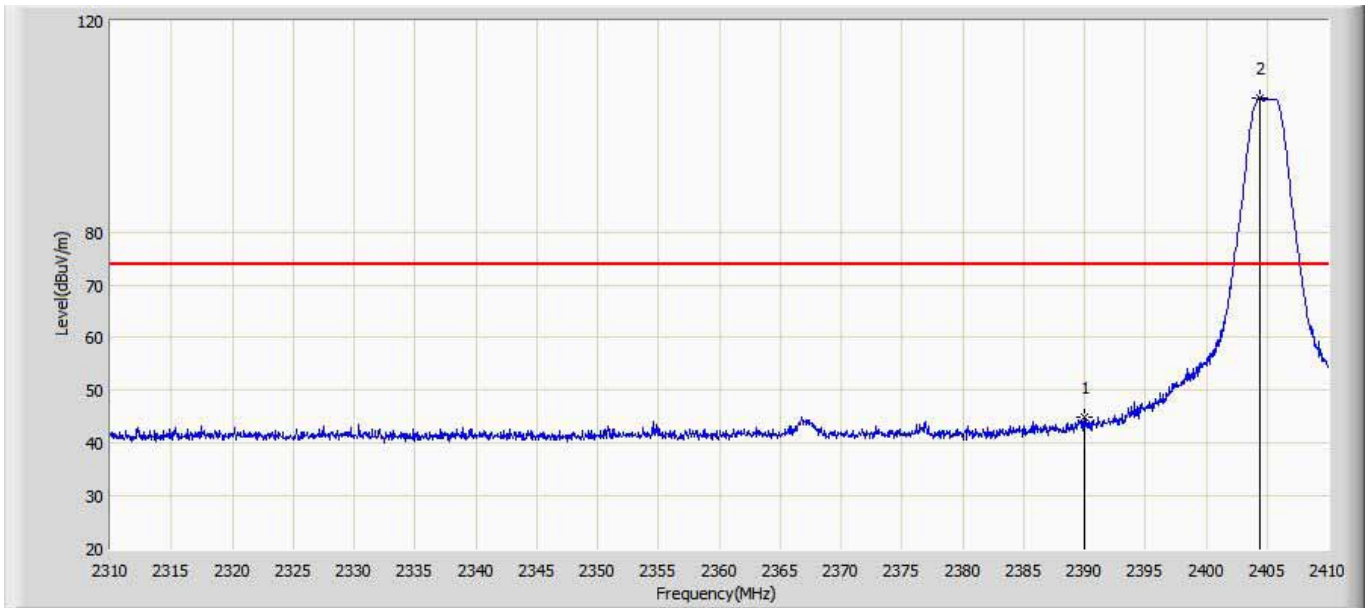

No	Mark	Frequency (MHz)	Measure Level (dBuV/m)	Reading Level (dBuV)	Over Limit (dB)	Limit (dBuV/m)	Factor (dB)	Type
1		2390.000	44.800	15.752	-29.200	74.000	30.510	PK
2	*	2404.450	105.345	76.411	N/A	N/A	30.484	PK

Site: AC5	Time: 2017/12/12 - 16:17
Limit: FCC_Part15.209_RE(3m)	Margin: 0
Probe: Horn_3117_00167055(1-18GHz)	Polarity: Vertical
EUT: LED lamp	Power: AC 120V/60Hz
Note: Mode 1:Transmit at 2405MHz by zigbee	

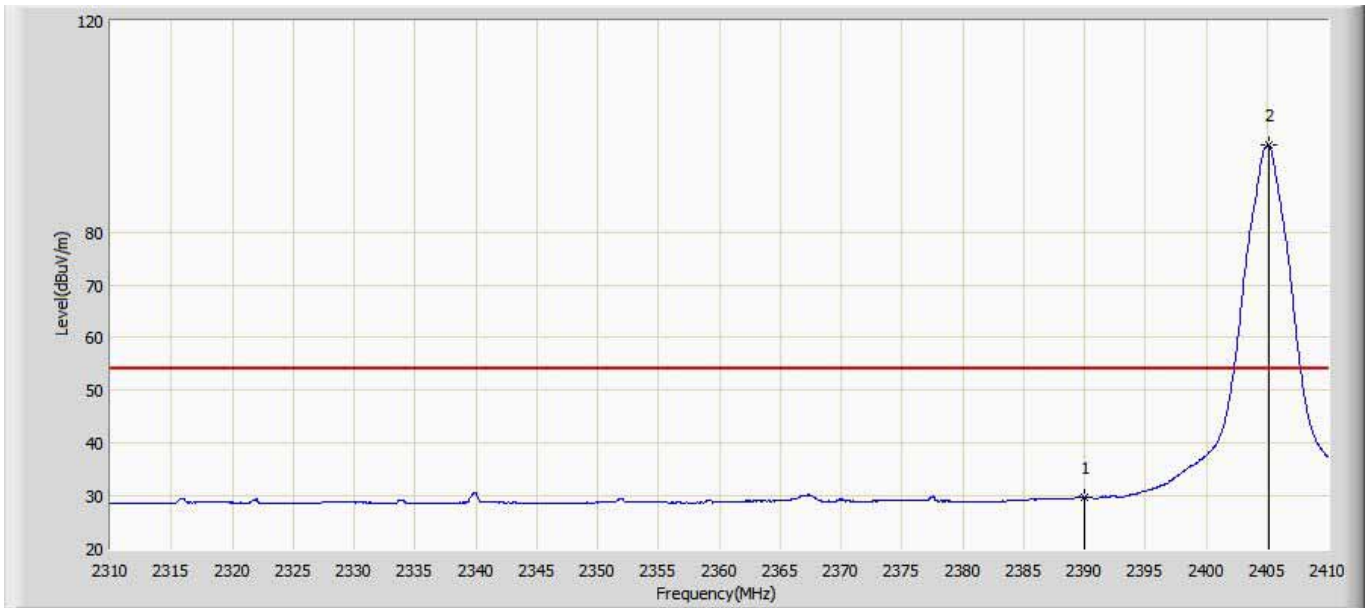

No	Mark	Frequency (MHz)	Measure Level (dBuV/m)	Reading Level (dBuV)	Over Limit (dB)	Limit (dBuV/m)	Factor (dB)	Type
1		2390.000	29.717	0.669	-24.283	54.000	30.510	AV
2	*	2405.100	96.380	67.453	N/A	N/A	30.484	AV

Site: AC5	Time: 2017/12/12 - 16:26
Limit: FCC_Part15.209_RE(3m)	Margin: 0
Probe: Horn_3117_00167055(1-18GHz)	Polarity: Vertical
EUT: LED lamp	Power: AC 120V/60Hz
Note: Mode 1:Transmit at 2405MHz by zigbee	

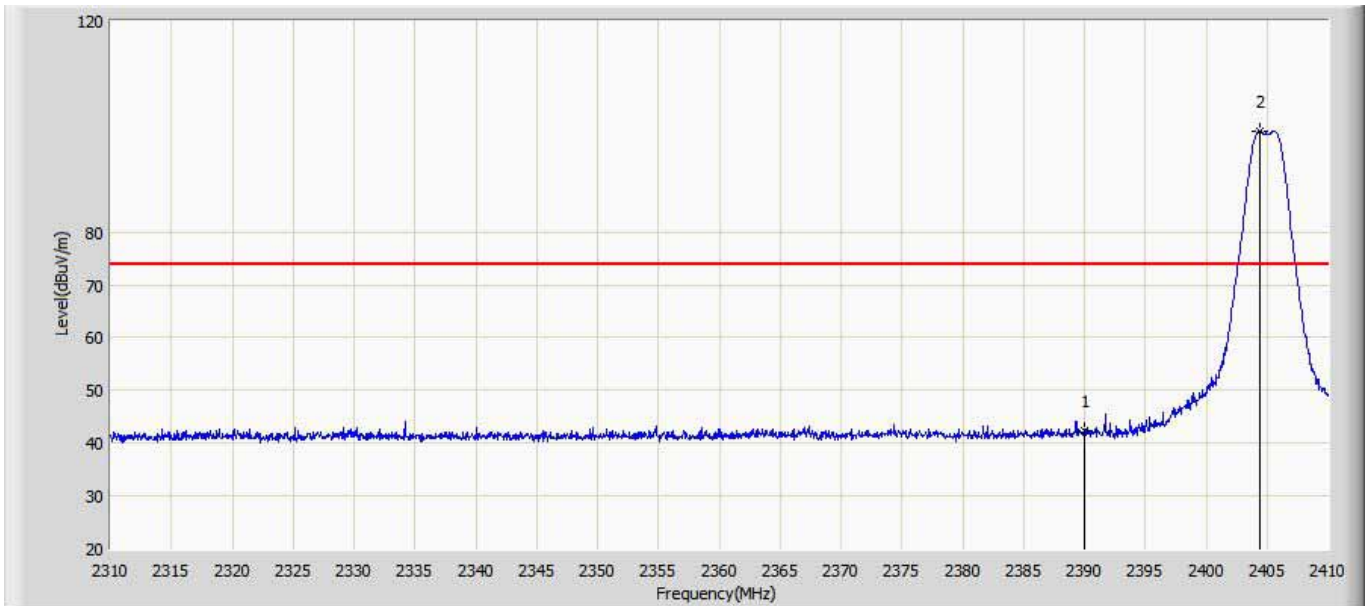

No	Mark	Frequency (MHz)	Measure Level (dBuV/m)	Reading Level (dBuV)	Over Limit (dB)	Limit (dBuV/m)	Factor (dB)	Type
1		2390.000	42.223	13.175	-31.777	74.000	30.510	PK
2	*	2404.350	99.045	70.110	N/A	N/A	30.484	PK

Site: AC5	Time: 2017/12/12 - 16:38
Limit: FCC_Part15.209_RE(3m)	Margin: 0
Probe: Horn_3117_00167055(1-18GHz)	Polarity: Horizontal
EUT: LED lamp	Power: AC 120V/60Hz
Note: Mode 1:Transmit at 2450MHz by zigbee	

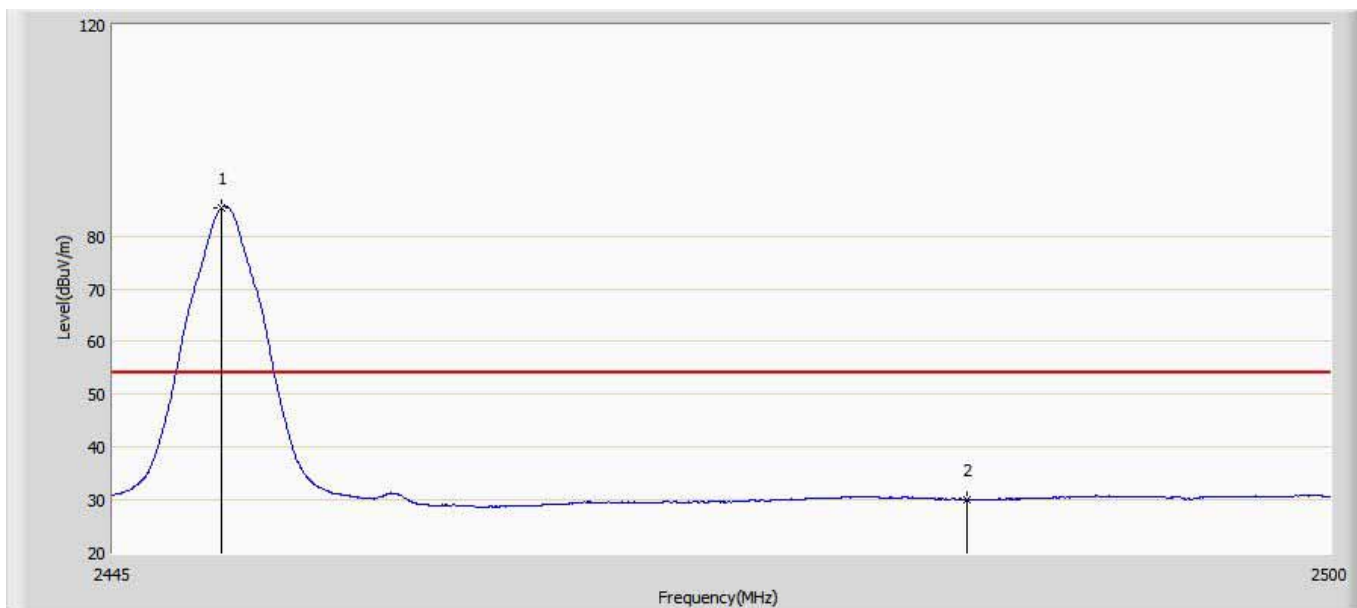

No	Mark	Frequency (MHz)	Measure Level (dBuV/m)	Reading Level (dBuV)	Over Limit (dB)	Limit (dBuV/m)	Factor (dB)	Type
1	*	2449.895	85.464	56.506	N/A	N/A	30.510	AV
2		2483.500	30.108	-0.376	-23.892	54.000	30.484	AV

Site: AC5	Time: 2017/12/12 - 16:48
Limit: FCC_Part15.209_RE(3m)	Margin: 0
Probe: Horn_3117_00167055(1-18GHz)	Polarity: Horizontal
EUT: LED lamp	Power: AC 120V/60Hz
Note: Mode 1:Transmit at 2450MHz by zigbee	

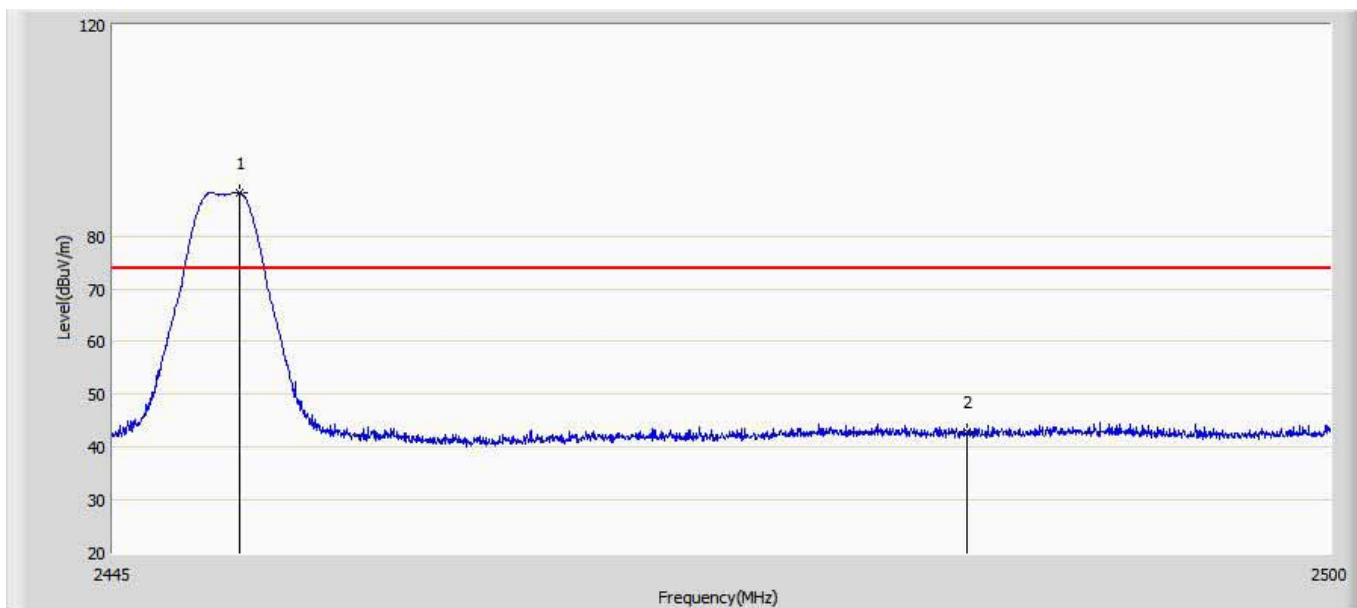

No	Mark	Frequency (MHz)	Measure Level (dBuV/m)	Reading Level (dBuV)	Over Limit (dB)	Limit (dBuV/m)	Factor (dB)	Type
1	*	2450.692	88.249	59.285	N/A	N/A	30.510	PK
2		2483.500	42.829	12.345	-31.171	74.000	30.484	PK

Site: AC5	Time: 2017/12/12 - 17:08
Limit: FCC_Part15.209_RE(3m)	Margin: 0
Probe: Horn_3117_00167055(1-18GHz)	Polarity:Vertical
EUT: LED lamp	Power: AC 120V/60Hz
Note: Mode 1:Transmit at 2450MHz by zigbee	

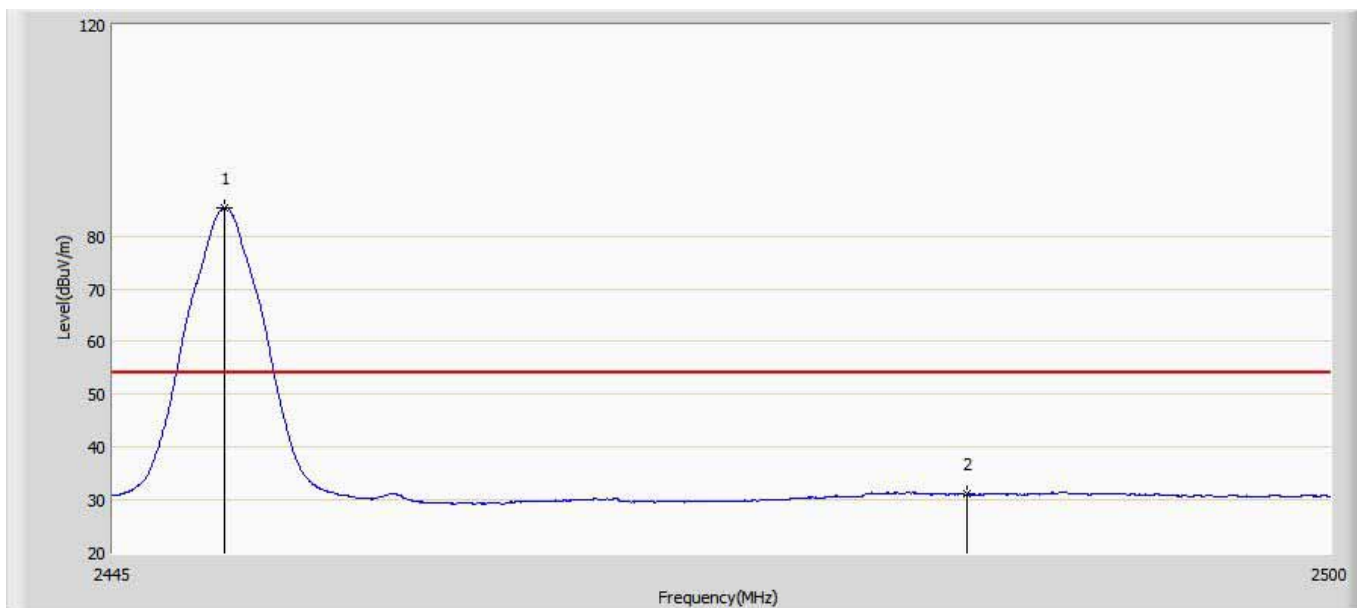

No	Mark	Frequency (MHz)	Measure Level (dBuV/m)	Reading Level (dBuV)	Over Limit (dB)	Limit (dBuV/m)	Factor (dB)	Type
1	*	2450.005	85.381	56.422	N/A	N/A	30.510	AV
2		2483.500	31.058	0.574	-22.942	54.000	30.484	AV

Site: AC5	Time: 2017/12/12 - 16:18
Limit: FCC_Part15.209_RE(3m)	Margin: 0
Probe: Horn_3117_00167055(1-18GHz)	Polarity: Vertical
EUT: LED lamp	Power: AC 120V/60Hz
Note: Mode 1:Transmit at 2450MHz by zigbee	

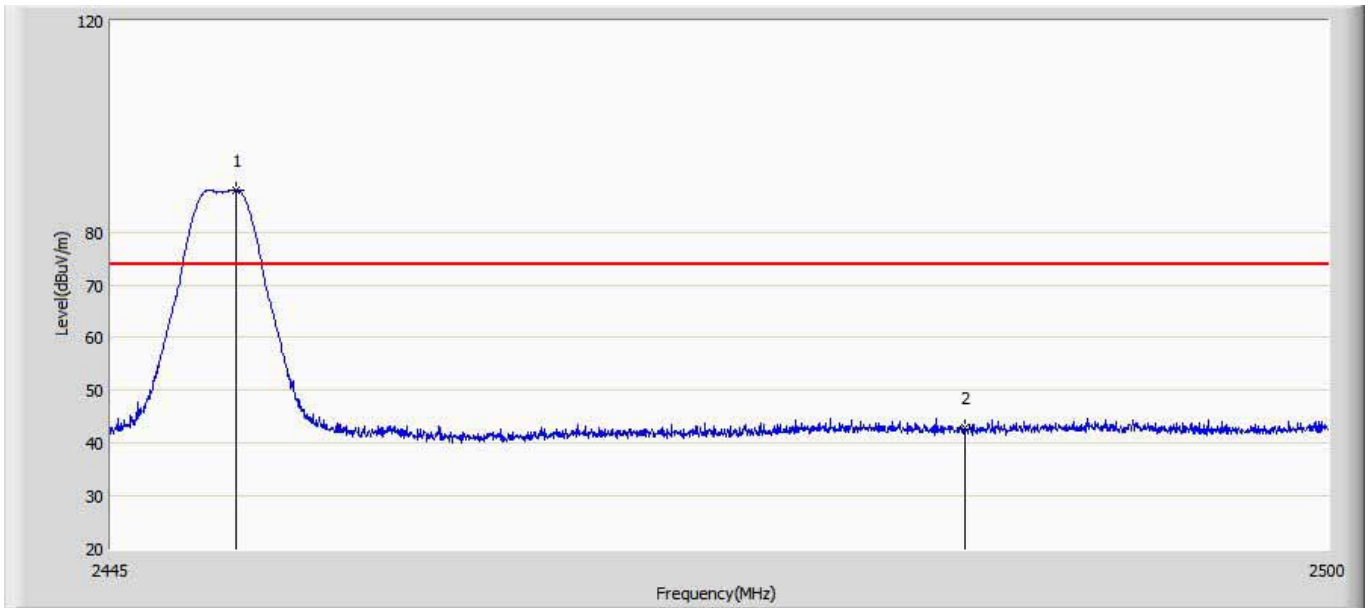

No	Mark	Frequency (MHz)	Measure Level (dBuV/m)	Reading Level (dBuV)	Over Limit (dB)	Limit (dBuV/m)	Factor (dB)	Type
1	*	2450.583	87.991	59.028	N/A	N/A	30.510	PK
2		2483.500	42.937	12.453	-31.062	74.000	30.484	PK

Site: AC5	Time: 2017/12/13 - 20:55
Limit: FCC_Part15.209_RE(3m)	Margin: 0
Probe: Horn_3117_00167055(1-18GHz)	Polarity: Horizontal
EUT: LED lamp	Power: AC 120V/60Hz
Note: Mode 1:Transmit at 2480MHz by zigbee	

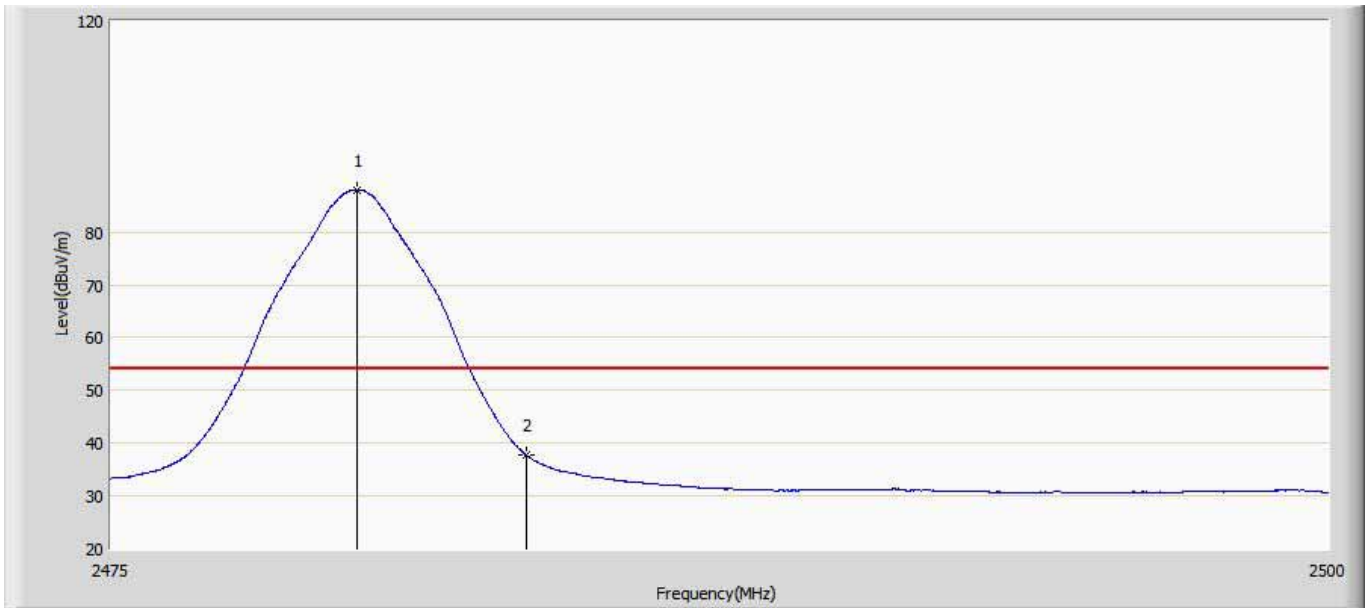

No	Mark	Frequency (MHz)	Measure Level (dBuV/m)	Reading Level (dBuV)	Over Limit (dB)	Limit (dBuV/m)	Factor (dB)	Type
1	*	2480.050	88.030	57.514	N/A	N/A	30.516	AV
2		2483.500	37.781	7.297	-16.219	54.000	30.484	AV

Site: AC5	Time: 2017/12/13 - 20:57
Limit: FCC_Part15.209_RE(3m)	Margin: 0
Probe: Horn_3117_00167055(1-18GHz)	Polarity: Horizontal
EUT: LED lamp	Power: AC 120V/60Hz
Note: Mode 1:Transmit at 2480MHz by zigbee	

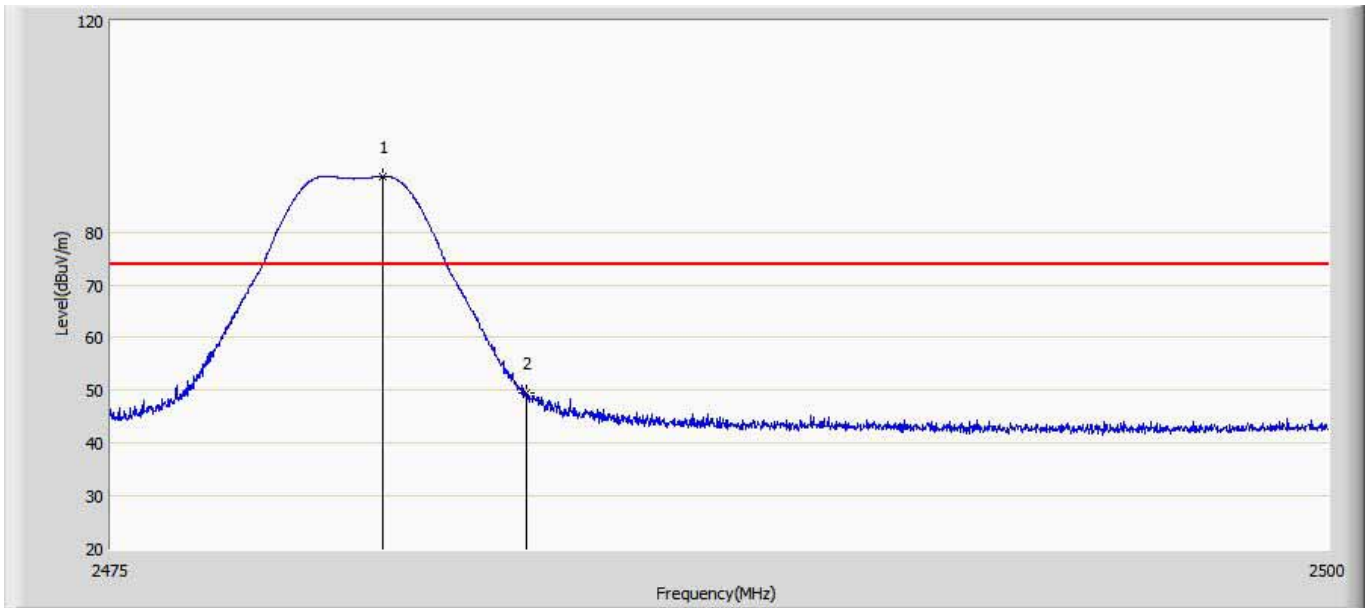

No	Mark	Frequency (MHz)	Measure Level (dBuV/m)	Reading Level (dBuV)	Over Limit (dB)	Limit (dBuV/m)	Factor (dB)	Type
1	*	2480.562	90.571	60.060	N/A	N/A	30.511	PK
2		2483.500	49.603	19.119	-24.397	74.000	30.484	PK

Site: AC5	Time: 2017/12/13 - 20:58
Limit: FCC_Part15.209_RE(3m)	Margin: 0
Probe: Horn_3117_00167055(1-18GHz)	Polarity: Vertical
EUT: LED lamp	Power: AC 120V/60Hz
Note: Mode 1:Transmit at 2480MHz by zigbee	

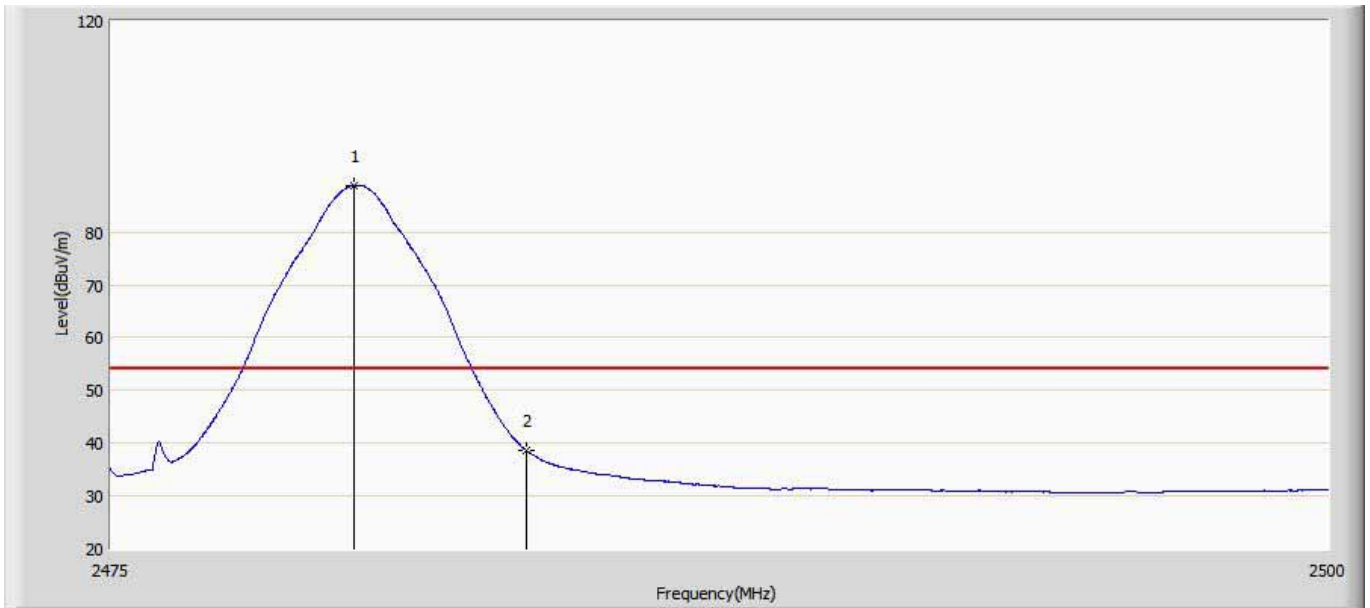

No	Mark	Frequency (MHz)	Measure Level (dBuV/m)	Reading Level (dBuV)	Over Limit (dB)	Limit (dBuV/m)	Factor (dB)	Type
1	*	2479.975	88.815	58.299	N/A	N/A	30.516	AV
2		2483.500	38.741	8.257	-15.259	54.000	30.484	AV

Site: AC5	Time: 2017/12/13 - 21:00
Limit: FCC_Part15.209_RE(3m)	Margin: 0
Probe: Horn_3117_00167055(1-18GHz)	Polarity: Vertical
EUT: LED lamp	Power: AC 120V/60Hz
Note: Mode 1:Transmit at 2480MHz by zigbee	

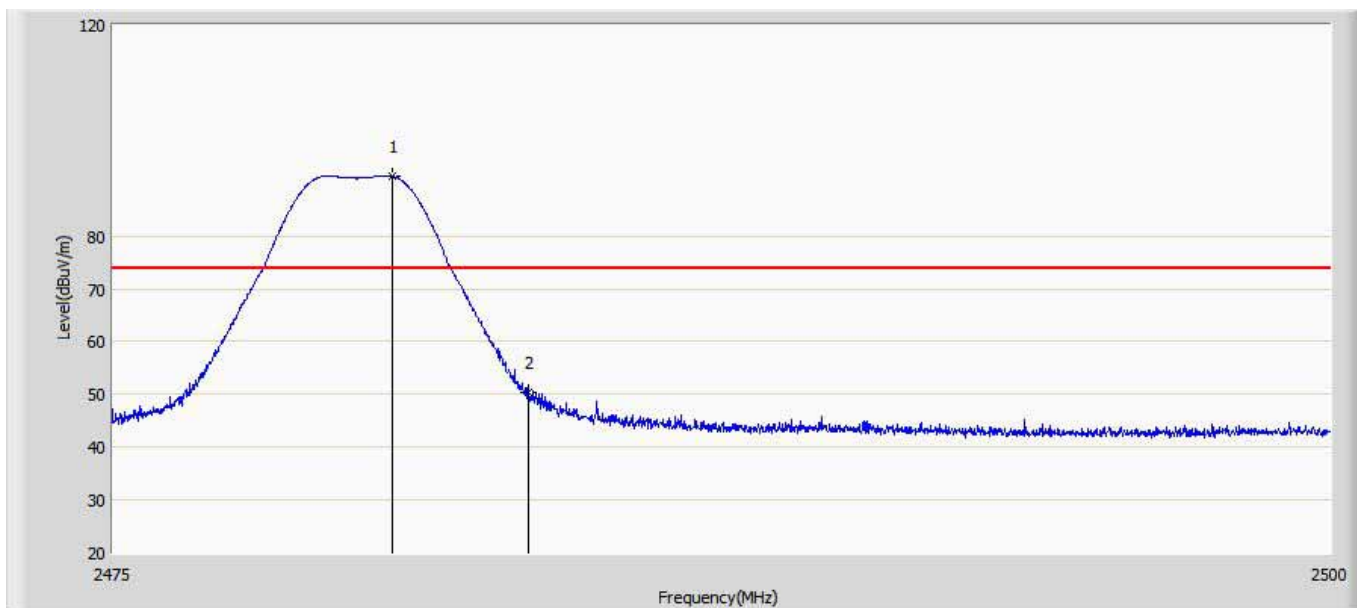

No	Mark	Frequency (MHz)	Measure Level (dBuV/m)	Reading Level (dBuV)	Over Limit (dB)	Limit (dBuV/m)	Factor (dB)	Type
1	*	2480.712	91.362	60.852	N/A	N/A	30.510	PK
2		2483.500	50.281	19.797	-23.719	74.000	30.484	PK

7. Occupied Bandwidth

7.1. Test Equipment

Occupied Bandwidth / TR-8					
Instrument	Manufacturer	Type No.	Serial No.	Cal. Date	Cal. Due Date
Spectrum Analyzer	Agilent	N9010A	MY48030494	2017.02.04	2018.02.03
EXA Spectrum Analyzer	Keysight	N9010A	MY55370495	2017.04.09	2018.04.08
MXA Signal Analyzer	Keysight	N9020A	MY56060147	2017.04.09	2018.04.08
Temperature/Humidity Meter	zhichen	ZC1-2	TR8-TH	2017.04.10	2018.04.09

Note: All equipment are calibrated with traceable calibrations. Each calibration is traceable to the national or international standards.

7.2. Test Setup

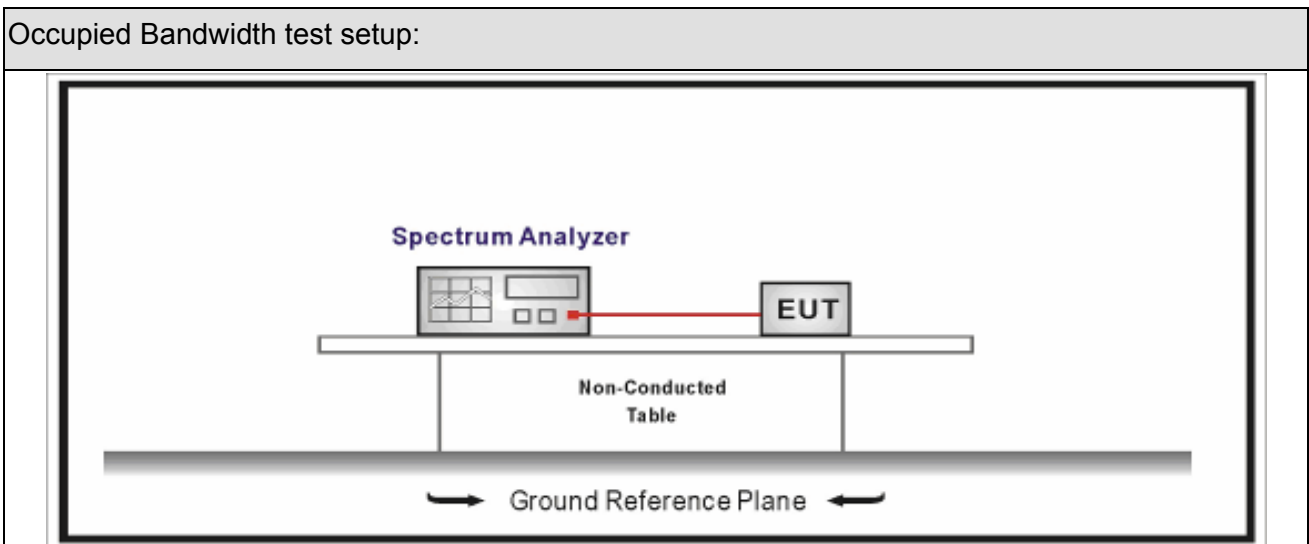



7.3. Limit

Occupied Bandwidth
Systems using digital modulation techniques operate in the 2400-2483.5 MHz. The minimum 6 dB bandwidth shall be at least 500 kHz

7.4. Test Procedure

Test Method			
	Reference Rule	Chapter	Description
<input checked="" type="checkbox"/>	ANSI C63.10	11.8	DTS bandwidth
<input type="checkbox"/>	ANSI C63.10	11.8.1	Option 1
<input checked="" type="checkbox"/>	ANSI C63.10	11.8.2	Option 2

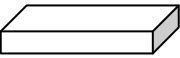
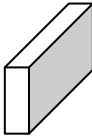
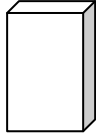
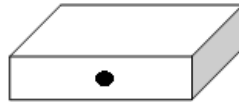
7.5. EUT test definition

Item	Occupied Bandwidth			
Device Category	<input type="checkbox"/>	Fixed point-to-point		
	<input type="checkbox"/>	Emit multiple directional beams, simultaneously or sequentially		
	<input checked="" type="checkbox"/>	Other cases		
Test mode	Mode 1			
Test method	<input type="checkbox"/>	Radiated		
		X Axis	Y Axis	Z Axis
				
		Worst Axis <input type="checkbox"/>	Worst Axis <input type="checkbox"/>	Worst Axis <input type="checkbox"/>
	<input checked="" type="checkbox"/>	Conducted		
	<input checked="" type="checkbox"/>	Chain 0		
				
	<input type="checkbox"/>	Chain 0	Chain 1	
				
	<input type="checkbox"/>	Chain 0	Chain 1	Chain 2
				

7.6. Test Result

Product Name	: LED lamp	Power	: AC 120V/60Hz
Test Mode	: Mode 1	Test Site	: TR-8
Test Date	: 2017.09.22	Test engineer	: Tommy

Mode	CH.	Test Freq. (MHz)	99% Occupied Bandwidth (kHz)	6dB Occupied Bandwidth (kHz)	Limit (kHz)	Result
1	11	2405	2279	1668	>500	Pass
1	20	2450	2273.3	1681	>500	Pass
1	26	2480	2259.6	1760	>500	Pass

Note : The worst case of Occupied Bandwidth as below:

Mode 1 CH11 (2405MHz)

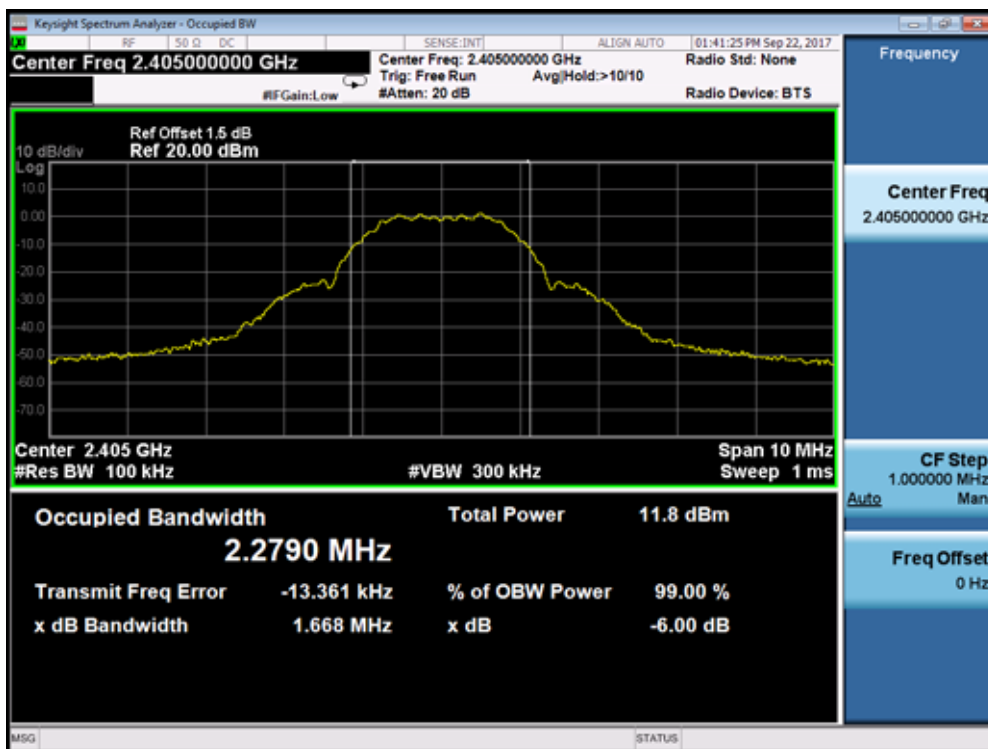

8. Fundamental emission output power

8.1. Test Equipment

Fundamental emission output power/ TR-8					
Instrument	Manufacturer	Type No.	Serial No.	Cal. Date	Cal. Due Date
Spectrum Analyzer	Agilent	E4446A	MY45300103	2017.01.04	2018.01.03
Spectrum Analyzer	Agilent	N9010A	MY48030494	2017.01.04	2018.01.03
Wideband Peak Power Meter	Anritsu	ML2495A	0905006	2017.10.14	2018.10.13
Power Sensor	Anritsu	MA2411B	0846014	2017.10.14	2018.10.13
Temperature/Humidity Meter	zhicheng	ZC1-2	TR8-TH	2017.04.10	2018.04.09

Note: All equipment are calibrated with traceable calibrations. Each calibration is traceable to the national or international standards.

8.2. Test Setup

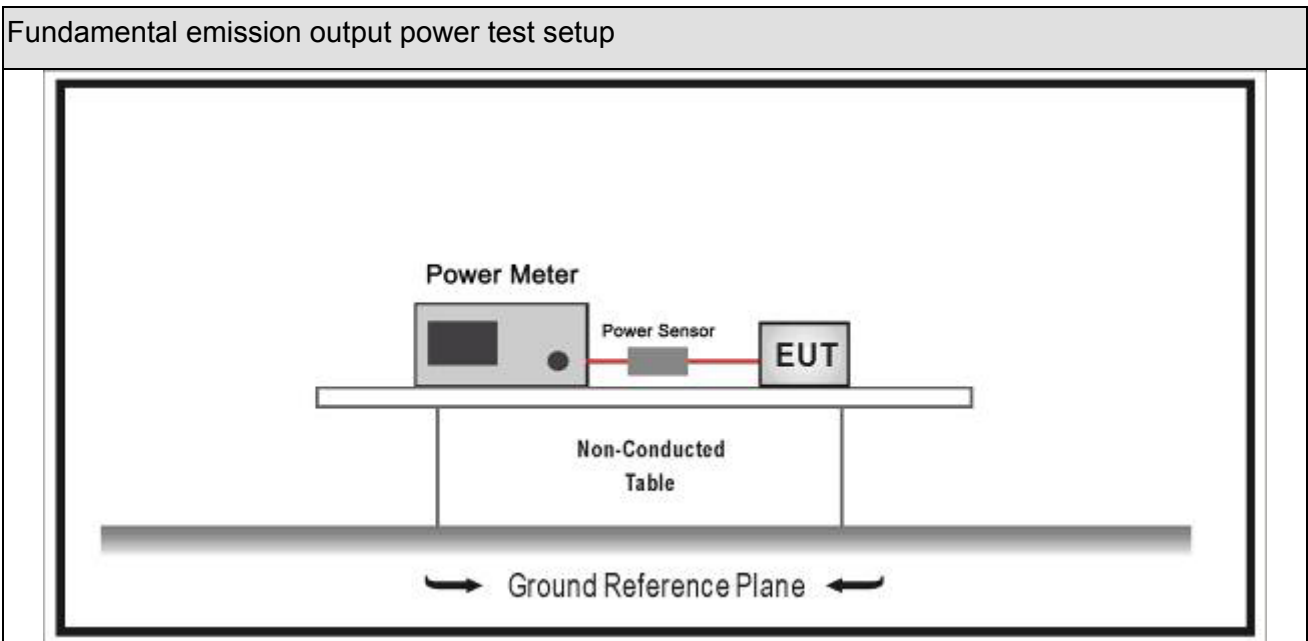





8.3. Limit

Fundamental emission output power Limit		
<input checked="" type="checkbox"/>	$G_{TX} < 6\text{dBi}$	$P_{out} \leq 30\text{dBm}$
<input type="checkbox"/>	$G_{TX} > 6\text{dBi}$	
<input type="checkbox"/>	Non-Fix point-point	$P_{out} \leq 30 - (G_{TX} - 6)$
<input type="checkbox"/>	Fix point-point	$P_{out} \leq 30 - [(G_{TX} - 6)]/3$
<input type="checkbox"/>	Point-to-multipoint	$P_{out} \leq 30 - (G_{TX} - 6)$
<input type="checkbox"/>	Overlap Beams	$P_{out} \leq 30 - [(G_{TX} - 6)]/3$
<input type="checkbox"/>	Aggregate power transmitted simultaneously on all beams	$P_{out} \leq 30 - [(G_{TX} - 6)]/3$
<input type="checkbox"/>	single directional beam	$P_{out} \leq 30 - [(G_{TX} - 6)]/3 + 8\text{dB}$
<p>Note 1 : G_{TX} directional gain of transmitting antennas.</p> <p>Note 2 : P_{out} is maximum peak conducted output power .</p>		

8.4. Test Procedure

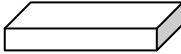
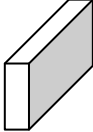
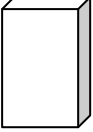
Fundamental emission output power Test Method					
	References Rule		Chapter	Description	
<input checked="" type="checkbox"/>	ANSI C63.10		11.9	Fundamental emission output power	
	<input checked="" type="checkbox"/>	ANSI C63.10		11.9.1	Maximum peak conducted output power
	<input type="checkbox"/>	ANSI C63.10	11.9.1.1	RBW \geq DTS bandwidth	
	<input type="checkbox"/>	ANSI C63.10	11.9.1.2	Integrated band power method	
	<input checked="" type="checkbox"/>	ANSI C63.10	11.9.1.3	PKPM1 Peak power meter method	
	<input type="checkbox"/>	ANSI C63.10		11.9.2	Maximum conducted (average) output power
	<input type="checkbox"/>	ANSI C63.10		11.9.2.2	Measurement using a spectrum analyzer (SA)
	<input type="checkbox"/>	ANSI C63.10	11.9.2.2.2	Method AVGSA-1(Duty cycle 98%)	
	<input type="checkbox"/>	ANSI C63.10	11.9.2.2.3	Method AVGSA-1A(Duty cycle 98%)	
	<input type="checkbox"/>	ANSI C63.10	11.9.2.2.4	Method AVGSA-2(Duty cycle 98%)	
	<input type="checkbox"/>	ANSI C63.10	11.9.2.2.5	Method AVGSA-2A(Duty cycle 98%)	
	<input type="checkbox"/>	ANSI C63.10	11.9.2.2.4	Method AVGSA-3	
	<input type="checkbox"/>	ANSI C63.10	11.9.2.2.5	Method AVGSA-3A	
	<input type="checkbox"/>	ANSI C63.10		11.9.2.3	Measurement using a power meter (PM)
	<input type="checkbox"/>	ANSI C63.10	11.9.2.3.1	Method AVGPM	
<input type="checkbox"/>	ANSI C63.10	11.9.2.3.2	Method AVGPM-G		

8.5. EUT test definition

Item	Fundamental emission output power			
Device Category	<input type="checkbox"/>	Fixed point-to-point		
	<input type="checkbox"/>	Emit multiple directional beams, simultaneously or sequentially		
	<input checked="" type="checkbox"/>	Other cases		
Test mode	Mode 1			
Test method	<input type="checkbox"/>	Radiated		
		X Axis	Y Axis	Z Axis
				
		Worst Axis <input type="checkbox"/>	Worst Axis <input type="checkbox"/>	Worst Axis <input type="checkbox"/>
	<input checked="" type="checkbox"/>	Conducted		
	<input checked="" type="checkbox"/>	Chain 0		
				
	<input type="checkbox"/>	Chain 0	Chain 1	
				
	<input type="checkbox"/>	Chain 0	Chain 1	Chain 2
				

8.6. Test Result

Product Name	: LED lamp	Power	: AC 120V/60Hz
Test Mode	: Mode 1	Test Site	: TR-8
Test Date	: 2017.09.30	Test engineer	: Tommy

The result for APT+Alvis+Diodes:

Mode	Channel	Test Frequency (MHz)	Measurement Power Output (dBm)	Limit (dBm)	Result
1	11	2405	8.56	30	Pass
1	20	2450	7.98	30	Pass
1	26	2480	7.76	30	Pass

The result for LTN+Alvis+Diodes:

Mode	Channel	Test Frequency (MHz)	Measurement Power Output (dBm)	Limit (dBm)	Result
1	11	2405	8.51	30	Pass
1	20	2450	7.88	30	Pass
1	26	2480	7.69	30	Pass

The result for APT+Alvis+Murata:

Mode	Channel	Test Frequency (MHz)	Measurement Power Output (dBm)	Limit (dBm)	Result
1	11	2405	8.01	30	Pass
1	20	2450	7.12	30	Pass
1	26	2480	7.62	30	Pass

9. Power Spectral Density

9.1. Test Equipment

Power Spectral Density / TR-8					
Instrument	Manufacturer	Type No.	Serial No.	Cal. Date	Cal. Due Date
Spectrum Analyzer	Agilent	N9010A	MY48030494	2017.02.04	2018.02.03
EXA Spectrum Analyzer	Keysight	N9010A	MY55370495	2017.04.09	2018.04.08
MXA Signal Analyzer	Keysight	N9020A	MY56060147	2017.04.09	2018.04.08
Temperature/Humidity Meter	zhichen	ZC1-2	TR8-TH	2017.04.10	2018.04.09

Note: All equipment are calibrated with traceable calibrations. Each calibration is traceable to the national or international standards.

9.2. Test Setup

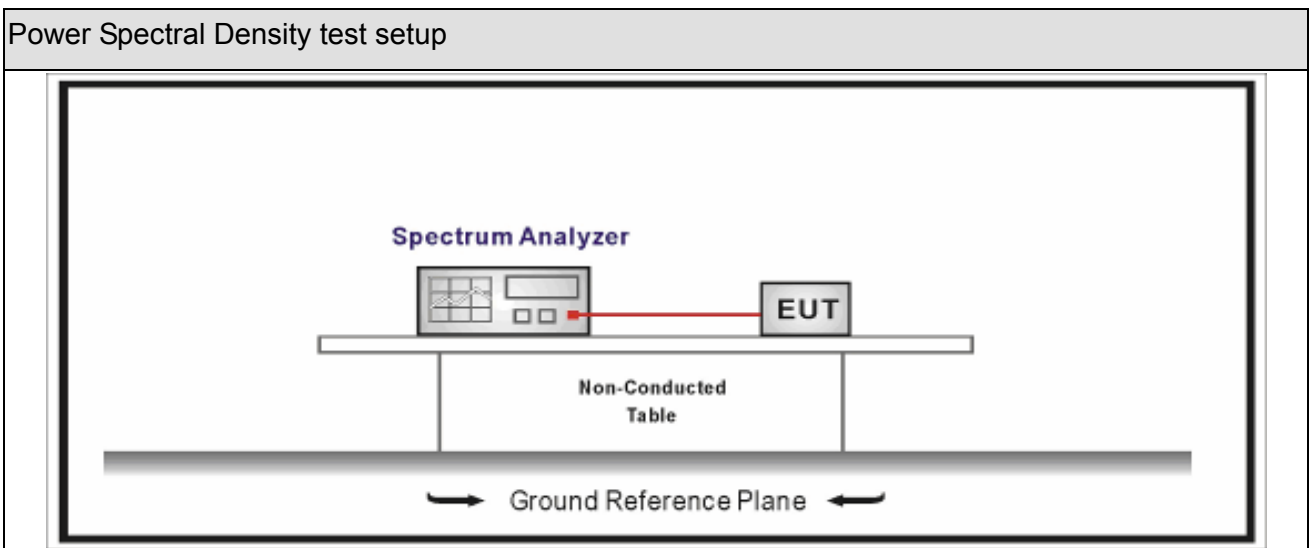

9.3. Limit

Power Spectral Density Limit
Power Spectral Density 8dBm/3kHz

9.4. Test Procedure

Power Spectral Density Test Method			
	References Rule	Chapter	Description
<input checked="" type="checkbox"/>	ANSI C63.10	11.10	Maximum power spectral density level in the fundamental emission
<input checked="" type="checkbox"/>	ANSI C63.10	11.10.2	Method PKPSD (peak PSD)
<input type="checkbox"/>	ANSI C63.10	11.10.3	Method AVGPSD-1(Duty cycle 98%)
<input type="checkbox"/>	ANSI C63.10	11.10.4	Method AVGPSD-1A(Duty cycle 98%)
<input type="checkbox"/>	ANSI C63.10	11.10.5	Method AVGPSD-2(Duty cycle < 98%)
<input type="checkbox"/>	ANSI C63.10	11.10.6	Method AVGPSD-2A(Duty cycle < 98%)
<input type="checkbox"/>	ANSI C63.10	11.10.7	Method AVGPSD-3
<input type="checkbox"/>	ANSI C63.10	11.10.8	Method AVGPSD-3A

9.5. EUT test definition

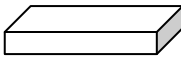
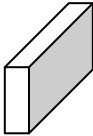
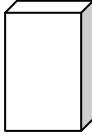
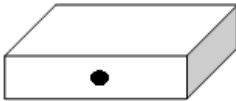
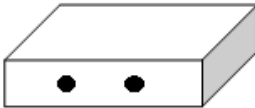
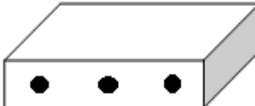
Item	Power Spectral Density Test Method			
Device Category	<input type="checkbox"/>	Fixed point-to-point		
	<input type="checkbox"/>	Emit multiple directional beams, simultaneously or sequentially		
	<input checked="" type="checkbox"/>	Other cases		
Test mode	Mode 1			
Test method	<input type="checkbox"/>	Radiated		
		X Axis	Y Axis	Z Axis
				
		Worst Axis <input type="checkbox"/>	Worst Axis <input type="checkbox"/>	Worst Axis <input type="checkbox"/>
	<input checked="" type="checkbox"/>	Conducted		
	<input checked="" type="checkbox"/>	Chain 0		
				
	<input type="checkbox"/>	Chain 0	Chain 1	
				
	<input type="checkbox"/>	Chain 0	Chain 1	Chain 2
				

9.6. Test Result

Product Name	: LED lamp	Power	: AC 120V/60Hz
Test Mode	: Mode 1	Test Site	: TR-8
Test Date	: 2017.09.22	Test engineer	: Tommy

Mode	Channel	Test Frequency (MHz)	Measurement PSD (dBm/3kHz)	Total PSD (dBm/3kHz)	Limit (dBm/3kHz)	Result
1	11	2405	1.960	1.960	8	Pass
1	15	2425	1.115	1.115	8	Pass
1	20	2450	0.956	0.956	8	Pass
1	25	2475	0.573	0.573	8	Pass
1	26	2480	0.197	0.197	8	Pass

Note : The worst case of Power Spectral Density as below:

Mode 1 CH26(2480MHz)

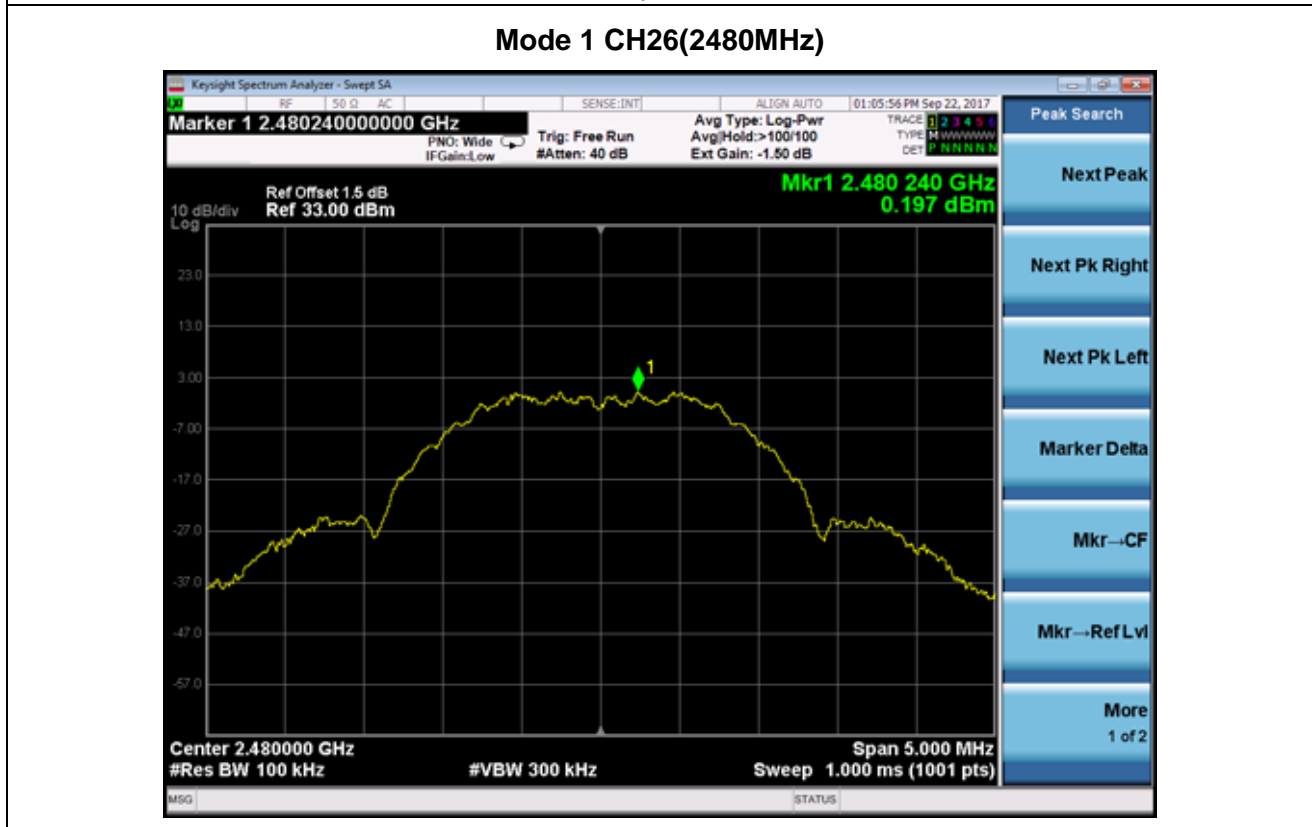

10. Antenna Requirement

10.1. Limit

Antenna Requirement Limit
<p>An intentional radiator shall be designed to ensure that no antenna other than that furnished by the responsible party shall be used with the device. The use of a permanently attached antenna or of an antenna that uses a unique coupling to the intentional radiator shall be considered sufficient to comply with the provisions of this section. The manufacturer may design the unit so that a broken antenna can be replaced by the user, but the use of a standard antenna jack or electrical connector is prohibited. This requirement does not apply to carrier current devices or to devices operated under the provisions of §15.211, §15.213, §15.217, §15.219, or §15.221. Further, this requirement does not apply to intentional radiators that must be professionally installed, such as perimeter protection systems and some field disturbance sensors, or to other intentional radiators which, in accordance with §15.31(d), must be measured at the installation site. However, the installer shall be responsible for ensuring that the proper antenna is employed so that the limits in this part are not exceeded.</p>

10.2. Antenna Connector Construction

Antenna Connector Construction	
<input checked="" type="checkbox"/>	The use of a permanently attached antenna
<input type="checkbox"/>	The antenna use of a unique coupling to the intentional radiator
<input type="checkbox"/>	The use of a nonstandard antenna jack or electrical connector
Please refer to the attached document "Internal Photograph" to show the antenna connector.	

_____ The End _____