

APPLICATION FOR CERTIFICATION

On Behalf of

Philips Lighting(China) Investment Co., Ltd.

LED Lamp

Model No. : 9290011998A

Brand : Philips

FCC ID : 2AGBW9290011998AX

Prepared for

Philips Lighting(China) Investment Co., Ltd.

Building 9, Lane 888, Tian Lin Road, Minhang district, Shanghai, China

Prepared by

Audix Technology (Wujiang) Co., Ltd. EMC Dept.

No. 1289 Jiangxing East Road, the Part of Wujiang Economic Development Zone
Jiangsu China 215200

Tel : +86-512-63403993

Fax :+86-512-63403339

Report Number : ACWE-F1608003A

Date of Test : Jul.30~Aug.02, 2016

Date of Report : Sep.05, 2016

TABLE OF CONTENTS

Description	Page
TEST REPORT CERTIFICATION	4
1. DESCRIPTION OF VERSION.....	5
2. SUMMARY OF MEASUREMENTS AND RESULTS	6
3. GENERAL INFORMATION.....	7
3.1. Description of Device (EUT).....	7
3.2. Description of Test Facility	8
3.3. Measurement Uncertainty.....	9
4. CONDUCTED EMISSION MEASUREMENT	10
4.1. Test Equipment.....	10
4.2. Block Diagram of Test Setup.....	10
4.3. Power line Conducted Emission Limit	10
4.4. Test Procedure	11
4.5. Conducted Emission Measurement Results.....	11
5. RADIATED EMISSION MEASUREMENT	18
5.1. Test Equipment.....	18
5.2. Block Diagram of Test Setup.....	18
5.3. Radiated Emission Limits.....	19
5.4. Test Procedure	19
5.5. Measurement Results.....	21
5.6. Restricted Bands Measurement Results (For Below 1GHz).....	22
5.7. Restricted Bands Measurement Results (For Above 1GHz)	28
5.8. Spurious Emission Measurement Results in Band Edge Emission (FCC Part 15, 15.205).....	34
6. 6 DB BANDWIDTH MEASUREMENT	42
6.1. Test Equipment.....	42
6.2. Block Diagram of Test Setup.....	42
6.3. Specification Limits (§15.247(a)(2))	42
6.4. Test Procedure	42
6.5. Test Results.....	42
7. OUTPUT POWER MEASUREMENT.....	45
7.1. Test Equipment.....	45
7.2. Block Diagram of Test Setup.....	45
7.3. Specification Limits (§15.247(b)(3)).....	45
7.4. Test Procedure	46
7.5. Test Results.....	46
8. BAND EDGES MEASUREMENT	47
8.1. Test Equipment.....	47
8.2. Block Diagram of Test Setup.....	47
8.3. Specification Limits (§15.247(d)).....	47
8.4. Test Procedure	47
8.5. Test Results.....	47
9. POWER SPECTRAL DENSITY MEASUREMENT	49
9.1. Test Equipment.....	49
9.2. Block Diagram of Test Setup.....	49
9.3. Specification Limits (§15.247(e)).....	49
9.4. Test Results.....	49

10. EMISSION LIMITATIONS MEASUREMENT.....	52
10.1. Test Equipment.....	52
10.2. Block Diagram of Test Setup.....	52
10.3. Specification Limits (§15.247(d)).....	52
10.4. Test Procedure.....	52
10.5. Test Results.....	53
11. DUTY CYCLE.....	76
11.1. Test Equipment.....	76
11.2. Test Results.....	76
12. DEVIATION TO TEST SPECIFICATIONS.....	77

TEST REPORT CERTIFICATION

Applicant : Philips Lighting(China) Investment Co., Ltd.
 Manufacturer : Philips Lighting(China) Investment Co., Ltd.
 EUT Description : LED Lamp
 FCC ID : 2AGBW9290011998AX
 (A) Model No. : 9290011998A
 (B) Brand : Philips
 (C) Power Supply : AC 110-130V, 60Hz
 (D) Test Voltage : AC 120V, 60Hz

Applicable Standards:

FCC RULES AND REGULATIONS PART 15 SUBPART C, Oct. 2015
ANSI C63.10: 2013

The device described above was tested by Audix Technology (Wujiang) Co., Ltd. EMC Dept. to determine the maximum emission levels emanating from the device. The maximum emission levels were compared to the FCC Part 15 subpart C section 15.207, 15.209&15.247 limits.

The measurement results are contained in this test report and Audix Technology (Wujiang) Co., Ltd. EMC Dept. is assumed full responsibility for the accuracy and completeness of these measurements. Also, this test report shows that the EUT to be technically compliant with the FCC limits.

This test report applies to above tested sample only. This test report shall not be reproduced in part without written approval of Audix Technology (Wujiang) Co., Ltd. EMC Dept.

Date of Test: Jul.30~Aug.02, 2016

Date of Report: Sep.05, 2016

Prepared by

:



(Emma Hu/Assistant Administrator)

Reviewer

:

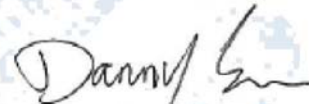

(Danny Sun/ Section Manager)

Approved & Authorized Signer

:



(Ken Lu/Assistant General Manager)

1. DESCRIPTION OF VERSION

Edition No.	Date of Rev.	Summary	Report No.
0	Aug.11, 2016	Original Report.	ACWE-F1608003
Rev. A	Sep.05, 2016	Add a new LED board.	ACWE-F1608003A

2. SUMMARY OF MEASUREMENTS AND RESULTS

The EUT has been tested according to the applicable standards and test results are referred as below.

Description of Test Item	Standard	Results	Remark
CONDUCTED EMISSION	FCC 47 CFR Part 15 Subpart C/ Section 15.207 And ANSI C63.10:2013	PASS	Minimum passing margin is 10.85 dB at 0.15 MHz
RADIATED EMISSION	FCC 47 CFR Part 15 Subpart C/ Section 15.209& Section 15.205 And ANSI C63.10:2013	PASS	Minimum passing margin is 8.06 dB at 32.38 MHz
6 dB BANDWIDTH	FCC 47 CFR Part 15 Subpart C/ Section 15.247(a)(2) And ANSI C63.10:2013	PASS	> 500kHz
OUTPUT POWER	FCC 47 CFR Part 15 Subpart C/ Section 15.247(b)(3) And ANSI C63.10:2013	PASS	Minimum passing margin is 27.54 dB at CH 26
BAND EDGES	FCC 47 CFR Part 15 Subpart C/ Section 15.247(d) And ANSI C63.10:2013	PASS	---
POWER SPECTRAL DENSITY	FCC 47 CFR Part 15 Subpart C/ Section 15.247(e) And ANSI C63.10:2013	PASS	Minimum passing margin is 8.359 dB at CH 26
EMISSION LIMITATIONS	FCC 47 CFR Part 15 Subpart C/ Section 15.247(d) And ANSI C63.10:2013	PASS	---

3. GENERAL INFORMATION

3.1. Description of Device (EUT)

Description	:	LED Lamp
Model No.	:	9290011998A
FCC ID	:	2AGBW9290011998AX
Brand	:	Philips
Applicant	:	Philips Lighting(China) Investment Co., Ltd. Building 9, Lane 888, Tian Lin Road, Minhang district, Shanghai, China
Manufacturer	:	Philips Lighting(China) Investment Co., Ltd. Building 9, Lane 888, Tian Lin Road, Minhang district, Shanghai, China
Radio Technology	:	IEEE 802.15.4 (ZigBee®)
Antenna Gain	:	1.65dBi
Fundamental Range	:	2405 MHz -2480MHz
Tested Frequency	:	2405MHz (CH11) 2450MHz (CH20) 2480MHz (CH26)
Channel Setting Method	:	Channel is changed according to EUT's power on or power off.
Highest Working Frequency	:	2.4GHz
Modulation type	:	O-QPSK
Date of Receipt of Sample	:	Jul.26, 2016
Date of Test	:	Jul.30~Aug.02, 2016

Remarks for Rev.A:

1. This report is based on the original report ACWE-F1608003.
2. This report changes the lamp's LED board. It has effect on the test result, so we retest it. The test result was recorded in this report ACWE-F1608003A.

3.2. Description of Test Facility

Name of Firm : **Audix Technology (Wujiang) Co., Ltd. EMC Dept.**

Site Location : No. 1289 Jiangxing East Road, the Eastern Part of Wujiang Economic Development Zone Jiangsu China 215200

Test Facilities : **No.1 Conducted Shielding Enclosure**
No.1 3m Semi-anechoic Chamber
 Date of Validity: Mar.30, 2018
 FCC Registration No.: 897661
 IC Registration No.:5183D-2
RF Fully Chamber

NVLAP Lab Code : 200786-0
 Valid until on Sep.30, 2016
 (NVLAP is a signatory member of ILAC MRA)
 Remark: This report shall not be imply endorsement, certification or approval by NVLAP, NIST, or any agency of the U.S. Federal Government.

3.3. Measurement Uncertainty

Test Item	Range Frequency	Uncertainty
No.1 Conducted Disturbance Measurement	0.15MHz ~ 30MHz	$\pm 2.65\text{dB}$
Radiated Disturbance Measurement (At 3m Chamber)	30MHz ~ 300MHz	$\pm 3.18\text{dB}$
	300MHz ~ 1GHz	$\pm 3.12\text{dB}$
Radiated Disturbance Measurement (At 3m Chamber)	1GHz ~ 6GHz	$\pm 4.56\text{dB}$
	6GHz ~ 18GHz	$\pm 5.03\text{dB}$

Remark: Uncertainty = $ku_c(y)$

Test Item	Uncertainty
6 dB Bandwidth	$\pm 0.16\text{ MHz}$
Maximum Peak Output Power	$\pm 0.12\text{dB}$
Band Edges	$\pm 0.38\text{dB}$
Power Spectral Density	$\pm 0.38\text{dB}$
Emission Limitations	$\pm 0.38\text{dB}$

Remark: Uncertainty = $ku_c(y)$

4. CONDUCTED EMISSION MEASUREMENT

4.1. Test Equipment

Item	Type	Manufacturer	Model No.	Serial No.	Last Cal.	Next Cal.
1.	Test Receiver	R & S	ESCI	100839	2016-01-05	2017-01-04
2.	A.M.N	R&S	ESH2-Z5	100153	2016-05-15	2017-05-14
3.	Pulse Limiter	R&S	ESH3-Z2	100605	2016-01-05	2017-01-04
4.	RF Cable	Harbour Industries	RG400	002	2016-01-05	2017-01-04
5.	Software	Audix/e3(6.7.0313)				

4.2. Block Diagram of Test Setup

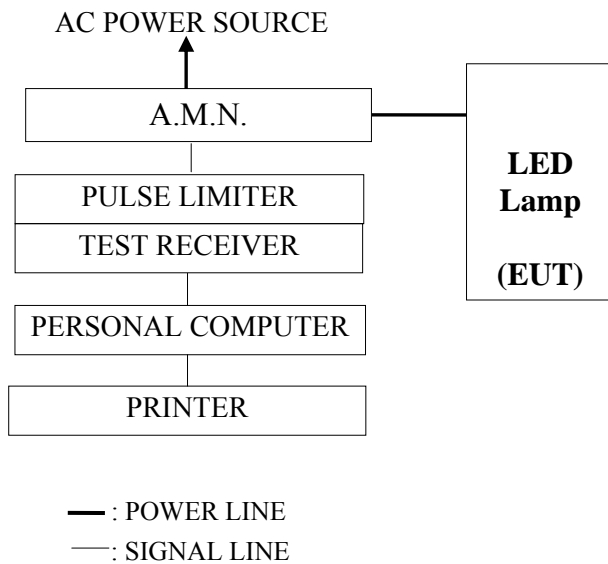

4.3. Power line Conducted Emission Limit

(FCC Part 15, Section 15.207, Class B)

Frequency	Maximum RF Line Voltage	
	Quasi-Peak Level	Average Level
150kHz ~ 500kHz	66 ~ 56 dB μ V	56 ~ 46 dB μ V
500kHz ~ 5MHz	56 dB μ V	46 dB μ V
5MHz ~ 30MHz	60 dB μ V	50 dB μ V

Remark1: If the average limit is met when using a Quasi-Peak detector, the EUT shall be deemed to meet both limits and measurement with the average detector is unnecessary.

2: The lower limit applies at the band edges.

4.4. Test Procedure

The measuring process is according to ANSI C63.10-2013 and laboratory internal procedure TKC-301-004. (For FCC Part15 Subpart C)

In the conducted emission measurement, the EUT and all peripheral devices were set up on a non-metallic table which was 0.8 meter height above the ground plane, and 0.4 meter far away from the vertical plane. The mains cable of the EUT connected to one Artificial Main Network(AMN). All other unit of the EUT and AE connected to a second Line Impedance Stabilization Network(L.I.S.N.). The telecommunication cable connected to the AE through a Impedance Stabilization Network(ISN) which terminated a 50Ω resistor. For the measurement, the A.M.N measuring port was terminated by a 50Ω measuring equipment and the second L.I.S.N measuring port was terminated by a 50Ω terminator. All measurements were done between the phase lead and the reference ground, and between the neutral lead and the reference ground. All cables or wires placement were verified to find out the maximum emission.

The bandwidth of measuring receiver was set at 9 kHz.

The required frequency band (0.15 MHz ~ 30 MHz) was pre-scanned with peak detector; the final measurement was measured with quasi-peak detector and average detector. (If the average limit is met when using a quasi-peak detector, the average detector is unnecessary).

The emission level is calculated automatically by the test system which uses the following equation:

$$\text{Emission level (dB}\mu\text{V)} = \text{Reading (dB}\mu\text{V)} + \text{A.M.N factor (dB)} + \text{Cable loss (dB)}.$$

(Cable loss includes pulse limiter loss)

4.5. Conducted Emission Measurement Results

For FCC Part15 Subpart C

PASSED.

EUT was performed during this section testing and all the test results are attached in next pages.

Test Date : Aug.02, 2016 Temperature : 23.2 Humidity : 59%

Mode	Test Condition	Reference Test Data No.	
		Neutral	Line
1	TX CH11 2405MHz	# 1	# 2
2	TX CH20 2450MHz	# 3	# 4
3	TX CH26 2480MHz	# 5	# 6

NOTE 1- ‘ ’ means the worst test mode.

NOTE 2- The worst emission is detected at 0.15 MHz with emission level of 55.15 dB (μV) and with QP detector (Limit is 66.00 dB (μV)), when the Line of the EUT is connected to AMN.



Audix Technology(Wujiang)Co.,Ltd.
 No.1289,Jiang Xing East Road,Eastern Part of WuJiang
 Economic Development Zone,JiangSu,China
 Tel:0512-63403993 Fax:0512-63403339

Data: 1 File: F:\2016Test Data\Report\G1608005R1.EM6 (10)

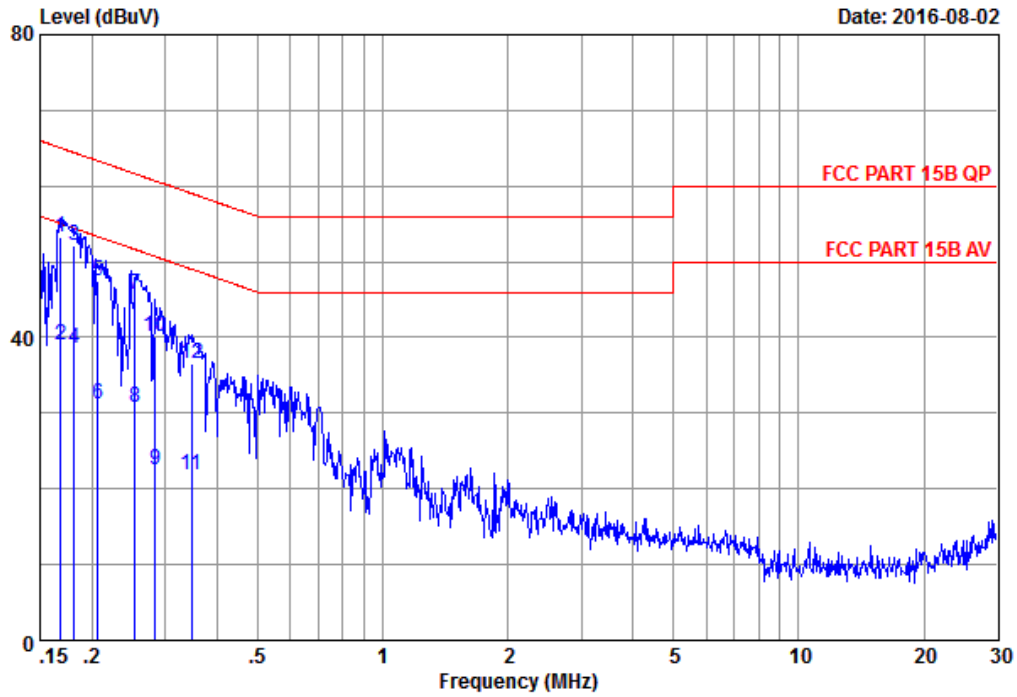

Site no. : No.1 Conducted shielding Enclosure Data no. : 1
 AMN/LISN : ESH2-Z5-1605 Phase : NEUTRAL
 Limit : FCC PART 15B QP
 Env. / Ins. : 23.2C&59%/ESCI Engineer : KM.Tong
 EUT : LED Lamp
 M/N : 9290011998A
 Power Rating : 120Vac/60Hz
 Test mode : TX CH11 2405MHz
 Memo

	Freq. (MHz)	AMN Factor (dB)	Cable Loss (dB)	Reading (dBuV)	Emission Level (dBuV)	Limits (dBuV)	Margin (dB)	Remark
1	0.17	0.15	9.89	43.30	53.34	65.03	11.69	QP
2	0.17	0.15	9.89	29.00	39.04	55.03	15.99	Average
3	0.18	0.15	9.89	42.00	52.04	64.42	12.38	QP
4	0.18	0.15	9.89	28.40	38.44	54.42	15.98	Average
5	0.21	0.15	9.89	37.50	47.54	63.33	15.79	QP
6	0.21	0.15	9.89	21.10	31.14	53.33	22.19	Average
7	0.25	0.15	9.89	35.61	45.65	61.65	16.00	QP
8	0.25	0.15	9.89	20.71	30.75	51.65	20.90	Average
9	0.28	0.15	9.89	12.51	22.55	50.70	28.15	Average
10	0.28	0.15	9.89	30.11	40.15	60.70	20.55	QP
11	0.35	0.16	9.90	11.79	21.85	49.05	27.20	Average
12	0.35	0.16	9.90	26.59	36.65	59.05	22.40	QP

Remarks:
 1.Emission Level= AMN factor + Cable loss(Include Pulse Att) + Reading .



Audix Technology(Wujiang)Co.,Ltd.
 No.1289,Jiang Xing East Road,Eastern Part of WuJiang
 Economic Development Zone,JiangSu,China
 Tel:0512-63403993 Fax:0512-63403339

Data: 2 File: F:\2016Test Data\Report\G1608005R1.EM6 (10)

Date: 2016-08-02

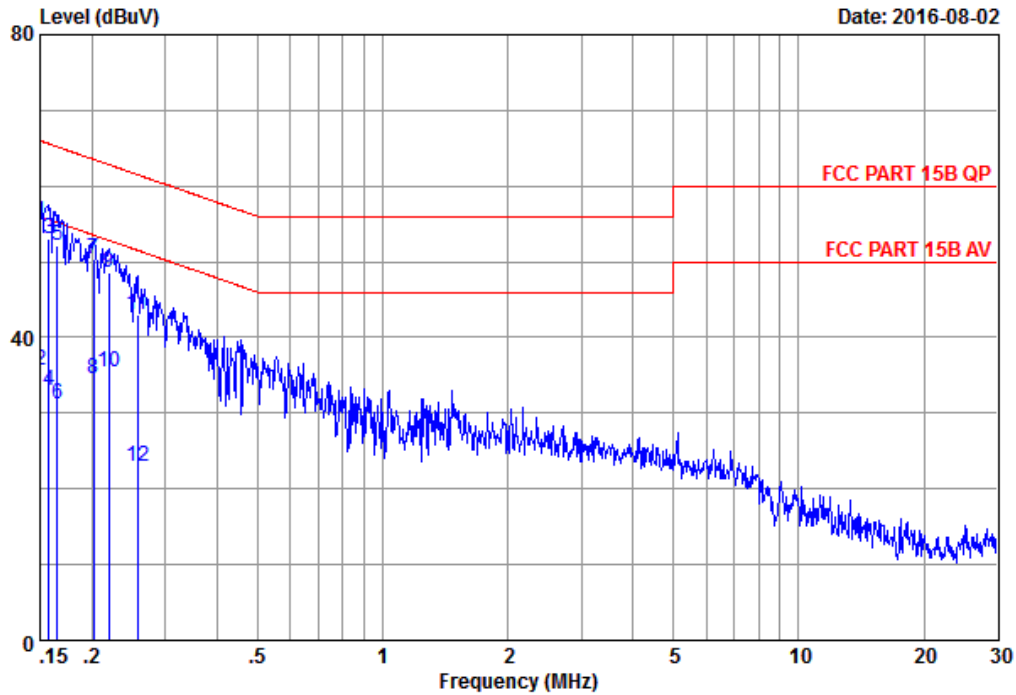

Site no. : No.1 Conducted shielding Enclosure Data no. : 2
 AMN/LISN : ESH2-Z5-1605 Phase : LINE
 Limit : FCC PART 15B QP
 Env. / Ins. : 23.2C&59%/ESCI Engineer : KM.Tong
 EUT : LED Lamp
 M/N : 9290011998A
 Power Rating : 120Vac/60Hz
 Test mode : TX CH11 2405MHz
 Memo

	Freq. (MHz)	AMN Factor (dB)	Cable Loss (dB)	Reading (dBuV)	Emission Level (dBuV)	Limits (dBuV)	Margin (dB)	Remark
1	0.15	0.16	9.89	45.10	55.15	66.00	10.85	QP
2	0.15	0.16	9.89	25.60	35.65	56.00	20.35	Average
3	0.16	0.16	9.89	43.00	53.05	65.59	12.54	QP
4	0.16	0.16	9.89	22.90	32.95	55.59	22.64	Average
5	0.16	0.16	9.89	42.00	52.05	65.22	13.17	QP
6	0.16	0.16	9.89	21.10	31.15	55.22	24.07	Average
7	0.20	0.16	9.89	40.30	50.35	63.54	13.19	QP
8	0.20	0.16	9.89	24.40	34.45	53.54	19.09	Average
9	0.22	0.16	9.89	38.50	48.55	62.84	14.29	QP
10	0.22	0.16	9.89	25.30	35.35	52.84	17.49	Average
11	0.26	0.16	9.89	33.01	43.06	61.52	18.46	QP
12	0.26	0.16	9.89	13.01	23.06	51.52	28.46	Average

Remarks:
 1.Emission Level= AMN factor + Cable loss(Include Pulse Att) + Reading .



Audix Technology(Wujiang)Co.,Ltd.
 No.1289,Jiang Xing East Road,Eastern Part of WuJiang
 Economic Development Zone,JiangSu,China
 Tel:0512-63403993 Fax:0512-63403339

Data: 3 File: F:\2016Test Data\Report\G1608005R1.EM6 (10)

Date: 2016-08-02

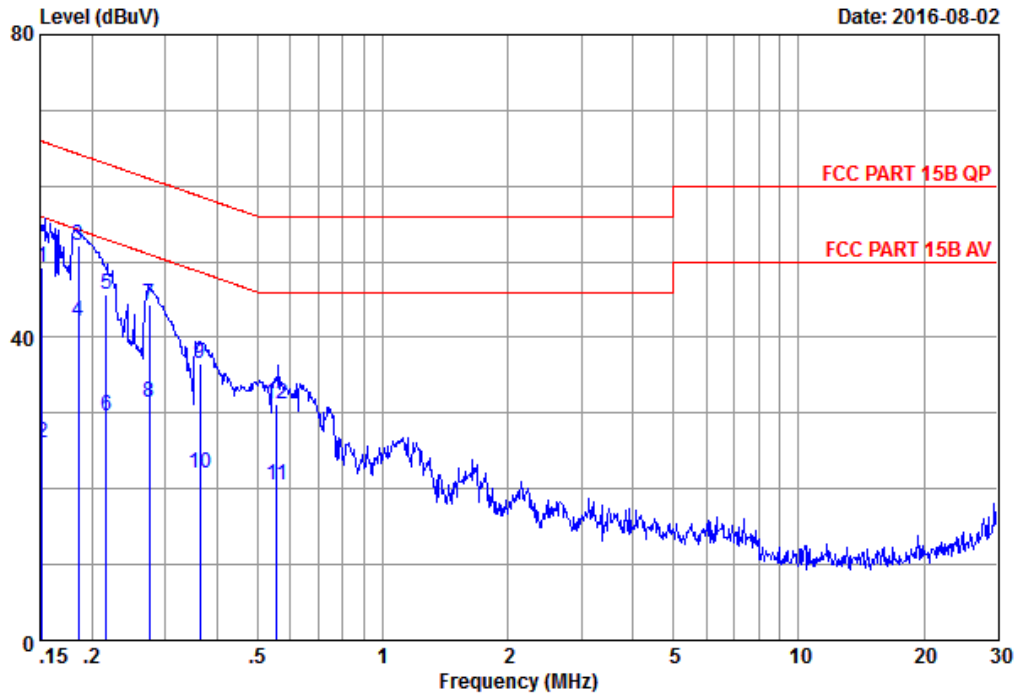

Site no. : No.1 Conducted shielding Enclosure Data no. : 3
 AMN/LISN : ESH2-Z5-1605 Phase : NEUTRAL
 Limit : FCC PART 15B QP
 Env. / Ins. : 23.2C&59%/ESCI Engineer : KM.Tong
 EUT : LED Lamp
 M/N : 9290011998A
 Power Rating : 120Vac/60Hz
 Test mode : TX CH20 2450MHz
 Memo

	Freq. (MHz)	AMN Factor (dB)	Cable Loss (dB)	Reading (dBuV)	Emission Level (dBuV)	Limits (dBuV)	Margin (dB)	Remark
1	0.15	0.15	9.89	39.10	49.14	65.89	16.75	QP
2	0.15	0.15	9.89	16.00	26.04	55.89	29.85	Average
3	0.19	0.15	9.89	42.00	52.04	64.23	12.19	QP
4	0.19	0.15	9.89	32.10	42.14	54.23	12.09	Average
5	0.22	0.15	9.89	35.70	45.74	62.94	17.20	QP
6	0.22	0.15	9.89	19.70	29.74	52.94	23.20	Average
7	0.27	0.15	9.89	34.21	44.25	60.99	16.74	QP
8	0.27	0.15	9.89	21.41	31.45	50.99	19.54	Average
9	0.36	0.16	9.90	26.49	36.55	58.63	22.08	QP
10	0.36	0.16	9.90	11.89	21.95	48.63	26.68	Average
11	0.56	0.16	9.90	10.40	20.46	46.00	25.54	Average
12	0.56	0.16	9.90	21.10	31.16	56.00	24.84	QP

Remarks:
 1.Emission Level= AMN factor + Cable loss(Include Pulse Att) + Reading .



Audix Technology(Wujiang)Co.,Ltd.
 No.1289,Jiang Xing East Road,Eastern Part of WuJiang
 Economic Development Zone,JiangSu,China
 Tel:0512-63403993 Fax:0512-63403339

Data: 4 File: F:\2016Test Data\Report\G1608005R1.EM6 (10)

Date: 2016-08-02

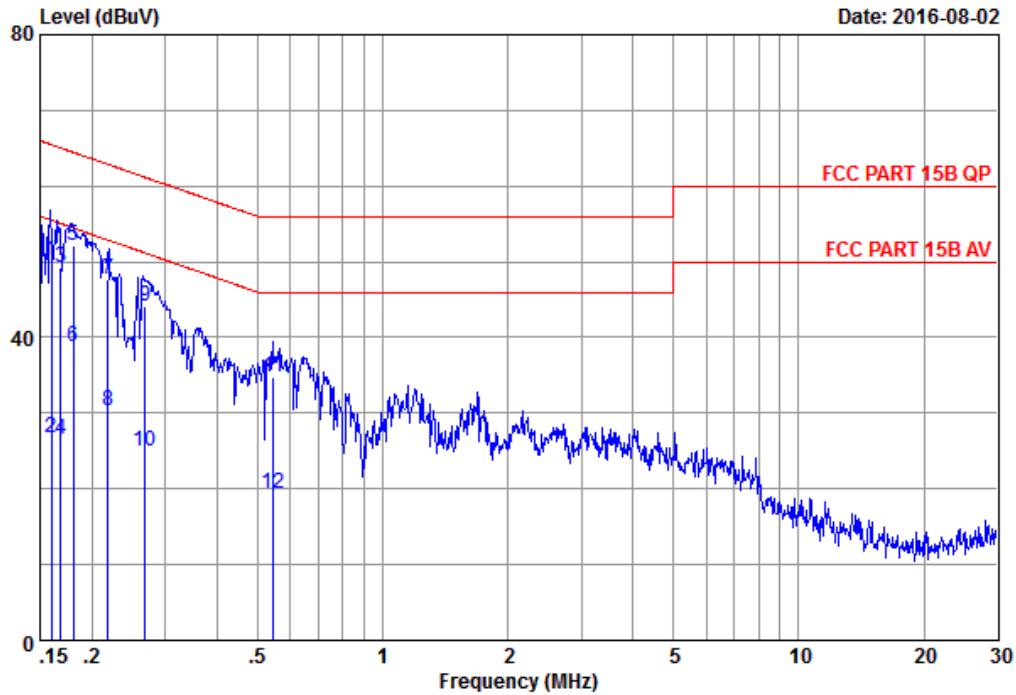

Site no. : No.1 Conducted shielding Enclosure Data no. : 4
 AMN/LISN : ESH2-Z5-1605 Phase : LINE
 Limit : FCC PART 15B QP
 Env. / Ins. : 23.2C&59%/ESCI Engineer : KM.Tong
 EUT : LED Lamp
 M/N : 9290011998A
 Power Rating : 120Vac/60Hz
 Test mode : TX CH20 2450MHz
 Memo

	Freq. (MHz)	AMN Factor (dB)	Cable Loss (dB)	Reading (dBuV)	Emission Level (dBuV)	Limits (dBuV)	Margin (dB)	Remark
1	0.16	0.16	9.89	40.00	50.05	65.47	15.42	QP
2	0.16	0.16	9.89	16.60	26.65	55.47	28.82	Average
3	0.17	0.16	9.89	39.10	49.15	65.03	15.88	QP
4	0.17	0.16	9.89	16.40	26.45	55.03	28.58	Average
5	0.18	0.16	9.89	42.10	52.15	64.46	12.31	QP
6	0.18	0.16	9.89	28.80	38.85	54.46	15.61	Average
7	0.22	0.16	9.89	37.70	47.75	62.88	15.13	QP
8	0.22	0.16	9.89	20.20	30.25	52.88	22.63	Average
9	0.27	0.16	9.89	34.01	44.06	61.18	17.12	QP
10	0.27	0.16	9.89	15.01	25.06	51.18	26.12	Average
11	0.55	0.17	9.90	24.80	34.87	56.00	21.13	QP
12	0.55	0.17	9.90	9.30	19.37	46.00	26.63	Average

Remarks:
 1.Emission Level= AMN factor + Cable loss(Include Pulse Att) + Reading .



Audix Technology(Wujiang)Co.,Ltd.
 No.1289,Jiang Xing East Road,Eastern Part of WuJiang
 Economic Development Zone,JiangSu,China
 Tel:0512-63403993 Fax:0512-63403339

Data: 5 File: F:\2016Test Data\Report\G1608005R1.EM6 (10)

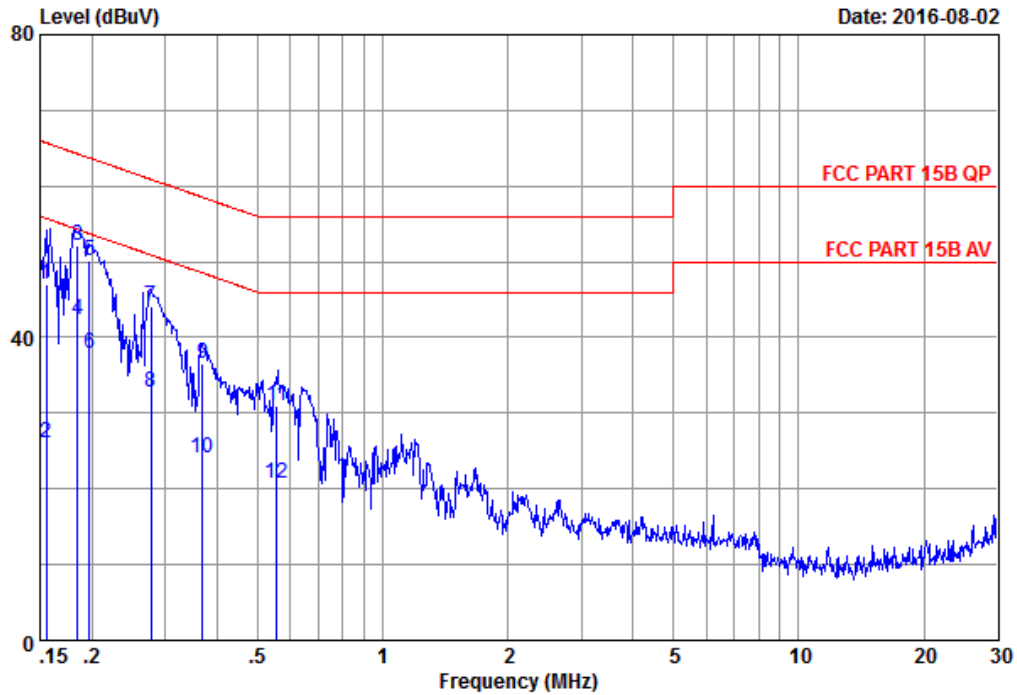

Site no. : No.1 Conducted shielding Enclosure Data no. : 5
 AMN/LISN : ESH2-Z5-1605 Phase : NEUTRAL
 Limit : FCC PART 15B QP
 Env. / Ins. : 23.2C&59%/ESCI Engineer : KM.Tong
 EUT : LED Lamp
 M/N : 9290011998A
 Power Rating : 120Vac/60Hz
 Test mode : TX CH26 2480MHz
 Memo

	Freq. (MHz)	AMN Factor (dB)	Cable Loss (dB)	Reading (dBuV)	Emission Level (dBuV)	Limits (dBuV)	Margin (dB)	Remark
1	0.16	0.15	9.89	37.00	47.04	65.71	18.67	QP
2	0.16	0.15	9.89	16.10	26.14	55.71	29.57	Average
3	0.19	0.15	9.89	42.00	52.04	64.26	12.22	QP
4	0.19	0.15	9.89	32.30	42.34	54.26	11.92	Average
5	0.20	0.15	9.89	40.10	50.14	63.74	13.60	QP
6	0.20	0.15	9.89	27.80	37.84	53.74	15.90	Average
7	0.28	0.15	9.89	34.01	44.05	60.91	16.86	QP
8	0.28	0.15	9.89	22.61	32.65	50.91	18.26	Average
9	0.37	0.16	9.90	26.49	36.55	58.52	21.97	QP
10	0.37	0.16	9.90	13.99	24.05	48.52	24.47	Average
11	0.56	0.16	9.90	20.90	30.96	56.00	25.04	QP
12	0.56	0.16	9.90	10.60	20.66	46.00	25.34	Average

Remarks:
 1.Emission Level= AMN factor + Cable loss(Include Pulse Att) + Reading .



Audix Technology(Wujiang)Co.,Ltd.
 No.1289,Jiang Xing East Road,Eastern Part of WuJiang
 Economic Development Zone,JiangSu,China
 Tel:0512-63403993 Fax:0512-63403339

Data: 6 File: F:\2016Test Data\Report\8\G1608005R1.EM6 (10)

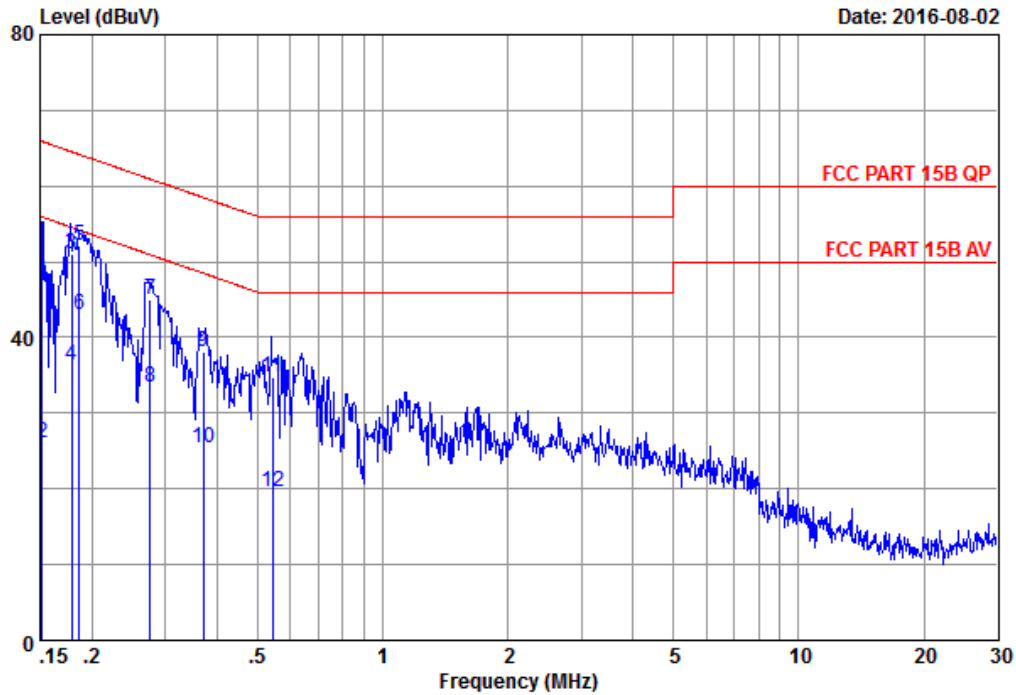

Site no. : No.1 Conducted shielding Enclosure Data no. : 6
 AMN/LISN : ESH2-Z5-1605 Phase : LINE
 Limit : FCC PART 15B QP
 Env. / Ins. : 23.2C&59%/ESCI Engineer : KM.Tong
 EUT : LED Lamp
 M/N : 9290011998A
 Power Rating : 120Vac/60Hz
 Test mode : TX CH26 2480MHz
 Memo

	Freq. (MHz)	AMN Factor (dB)	Cable Loss (dB)	Reading (dBuV)	Emission Level (dBuV)	Limits (dBuV)	Margin (dB)	Remark
1	0.15	0.16	9.89	37.40	47.45	65.91	18.46	QP
2	0.15	0.16	9.89	16.10	26.15	55.91	29.76	Average
3	0.18	0.16	9.89	41.00	51.05	64.55	13.50	QP
4	0.18	0.16	9.89	26.20	36.25	54.55	18.30	Average
5	0.19	0.16	9.89	42.10	52.15	64.18	12.03	QP
6	0.19	0.16	9.89	32.90	42.95	54.18	11.23	Average
7	0.28	0.16	9.89	35.01	45.06	60.94	15.88	QP
8	0.28	0.16	9.89	23.41	33.46	50.94	17.48	Average
9	0.37	0.17	9.90	27.99	38.06	58.47	20.41	QP
10	0.37	0.17	9.90	15.39	25.46	48.47	23.01	Average
11	0.54	0.17	9.90	24.60	34.67	56.00	21.33	QP
12	0.54	0.17	9.90	9.50	19.57	46.00	26.43	Average

Remarks:
 1.Emission Level= AMN factor + Cable loss(Include Pulse Att) + Reading .

5. RADIATED EMISSION MEASUREMENT

5.1. Test Equipment

The following test equipment was used during the radiated emission measurement:
At 3m Semi-Anechoic Chamber

Item	Type	Manufacturer	Model No.	Serial No.	Last Cal.	Next Cal.
1.	Preamplifier	Agilent	8449B	3008A02233	2016-01-05	2017-01-04
2.	Preamplifier	Agilent	8447D	2944A10921	2016-07-03	2017-07-02
3.	PXA Signal Analyzer	Agilent	N9030A	MY53120367	2016-05-15	2017-05-14
4.	Test Receiver	R&S	ESCI	100361	2016-01-05	2017-01-04
5.	Bi-log Antenna	Schaffner	CBL6112D	22250	2015-09-02	2016-09-01
6.	Horn Antenna	EMCO	3115	62961	2015-09-23	2016-09-22
7.	RF Cable #1	Yuhang CSYH	cable-3m	001(0.5m)	2016-01-05	2017-01-04
8.	RF Cable #2	Yuhang CSYH	cable-3m	002(0.5m)	2016-01-05	2017-01-04
9.	RF Cable #3	Yuhang CSYH	cable-3m	003(3.0m)	2016-01-05	2017-01-04
10.	Software	Audix/e3(6.7.0313)				

5.2. Block Diagram of Test Setup

5.2.1. Block Diagram of Test Setup between EUT and simulators

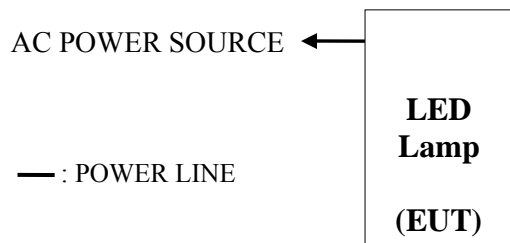

5.2.2. No. 1 3m Semi-Anechoic Chamber Setup Diagram (Test distance:3m) for 30-1000MHz

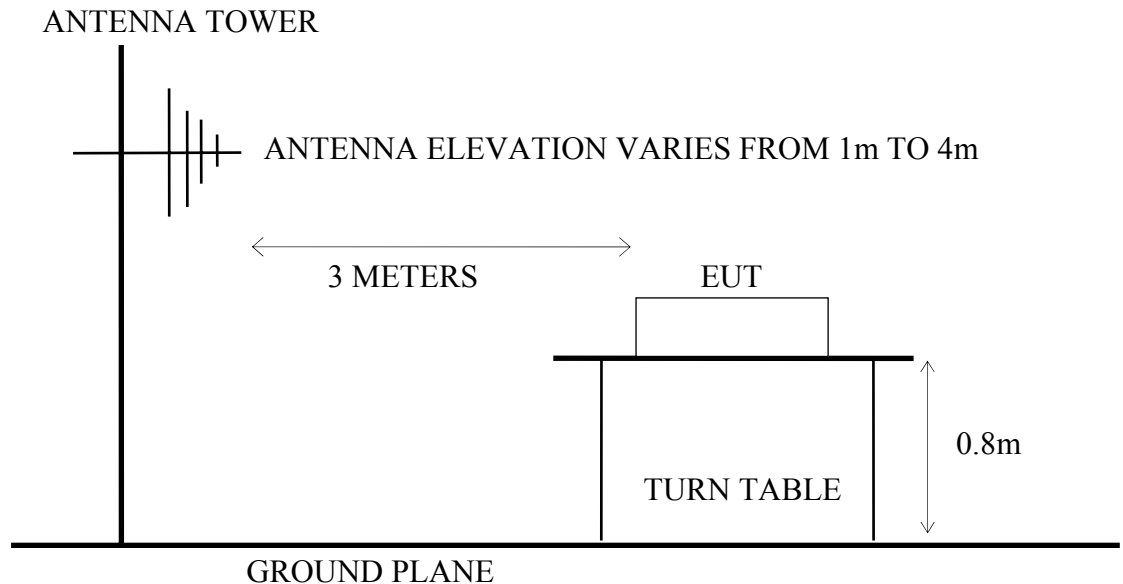

5.2.3. No. 1 3m Semi-Anechoic Chamber Setup Diagram (Test distance: 3m) for above 1GHz

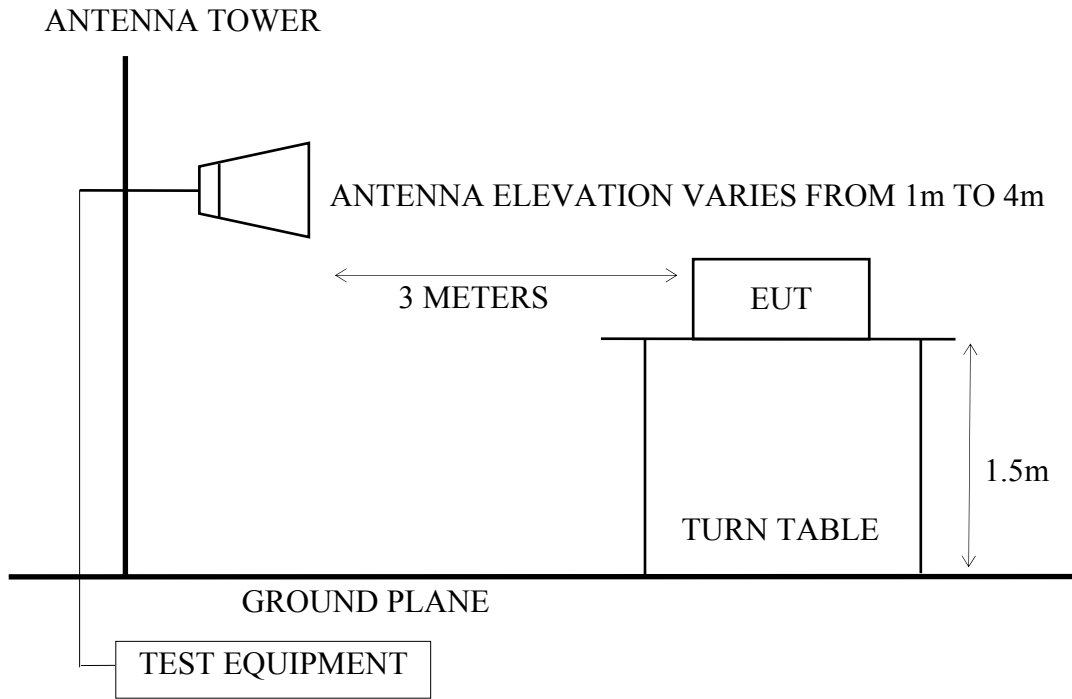

5.3. Radiated Emission Limits

Radiated Emission Limits (FCC Part15 C, section 15.209, CISPR22)

Frequency MHz	Distance Meters	Field Strengths Limits
		dB μ V/m
30 ~ 88	3	40
88 ~ 216	3	43.5
216 ~ 960	3	46
Above 960	3	54
Above 1000	3	74 (Peak) 54 (Average)

- Remark : (1) Emission level (dB μ V/m) = 20 log Emission level (μ V/m)
 (2)The tighter limit applies at the edge between two frequency bands.

5.4. Test Procedure

The measuring process is according to ANSI C63.10-2013 and laboratory internal procedure TKC-301-001. (For FCC Part15 Subpart C)

In the radiated disturbance measurement, the EUT and all simulators were set up on a non-metallic turn table which was 0.8 meter above the ground plane. Measurement distance between EUT and receiving antennas was set at 10 meters at 30MHz~1GHz and 3 meters at 1GHz~6GHz. The measurement distance is the shortest horizontal distance between an imaginary circular periphery which consists of EUT periphery and cables and the reference point of the antenna. During the radiated measurement, the EUT was rotated 360° and receiving antennas were moved from 1 ~ 4 meters for finding maximum emission. Two receiving antennas were used for both horizontal and vertical polarization detection for 30MHz~1GHz, One receiving antennas was used for both horizontal and vertical polarization detection for 1GHz~6GHz (the absorbing material was added when testing of 1GHz~6GHz was done). All cables or wires placement were verified to find out the maximum emission.

The bandwidth of measuring receiver (or spectrum analyzer) was set to:

RBW (120 kHz), VBW (300 kHz) for QP detector below 1GHz
RBW (1 MHz), VBW (1MHz) for Peak detector above 1GHz
RBW (1 MHz), VBW (10Hz) for AV detector above 1GHz

The frequency range from 30MHz to 10th harmonic(25GHz) are checked, and no any emissions were found from 18GHz to 25GHz.

The emission level is calculated automatically by the test system which uses the following equation :

1. For 30MHz-1GHz measurement:
Emission Level (dB μ V/m) = Reading (dB μ V)+Antenna Factor (dB/m)+Cable Loss (dB)
2. For Above 1GHz measurement:
Emission Level (dB μ V/m) = Reading (dB μ V)+Antenna Factor (dB/m)+Cable Loss(dB)
-Pre-amplifier factor (dB)

The three orthogonal planes have been all tested, and the data of the worst mode XZ plan(in Horizontal) & XY plan(in Vertical) is shown in the report.

5.5. Measurement Results

PASSED

5.5.1. For Restricted Bands:

The EUT was tested in restricted bands and all the test results are listed in section 5.7 & 5.8. (The restricted bands defined in part 15.205(a))

For Frequency range : below 1GHz

No.	Test Mode and Frequency		Reference Test Data No.	
			Horizontal	Vertical
1.	Transmitting	2405MHz (Channel 11)	# 7	# 8
2.		2450MHz (Channel 20)	# 9	# 10
3.		2480MHz (Channel 26)	# 11	# 12

For Frequency range : above 1GHz

No.	Test Mode and Frequency		Reference Test Data No.	
			Horizontal	Vertical
1.	Transmitting	2405MHz (Channel 11)	# 13	# 14
2.		2450MHz (Channel 20)	# 15	# 16
3.		2480MHz (Channel 26)	# 17	# 18

5.5.2. For Band Edge Emission

The EUT was tested in restricted bands and all the test results are listed in section 5.9. The restricted bands defined in part 15.205(a)

No.	Test Mode and Frequency		Reference Test Data No.	
			Horizontal	Vertical
1.	Transmitting	2405MHz (Channel 11)	# 19, # 21	# 20, # 22
2.		2480MHz (Channel 26)	# 23, # 25	# 24, # 26

5.6. Restricted Bands Measurement Results (For Below 1GHz)



Audix Technology(Wujiang)Co.,Ltd.
 No.1289,Jiang Xing East Road,The Eastern Part of Wu Jiang
 Economic Development Zone,JiangSu,China
 Tel: (0512) 63403993 Fax: (0512) 63403993

Data: 7 File: G:\Test Data\2016\Reports\08\G1608005R1.EM6 (26) Date: 2016-08-01

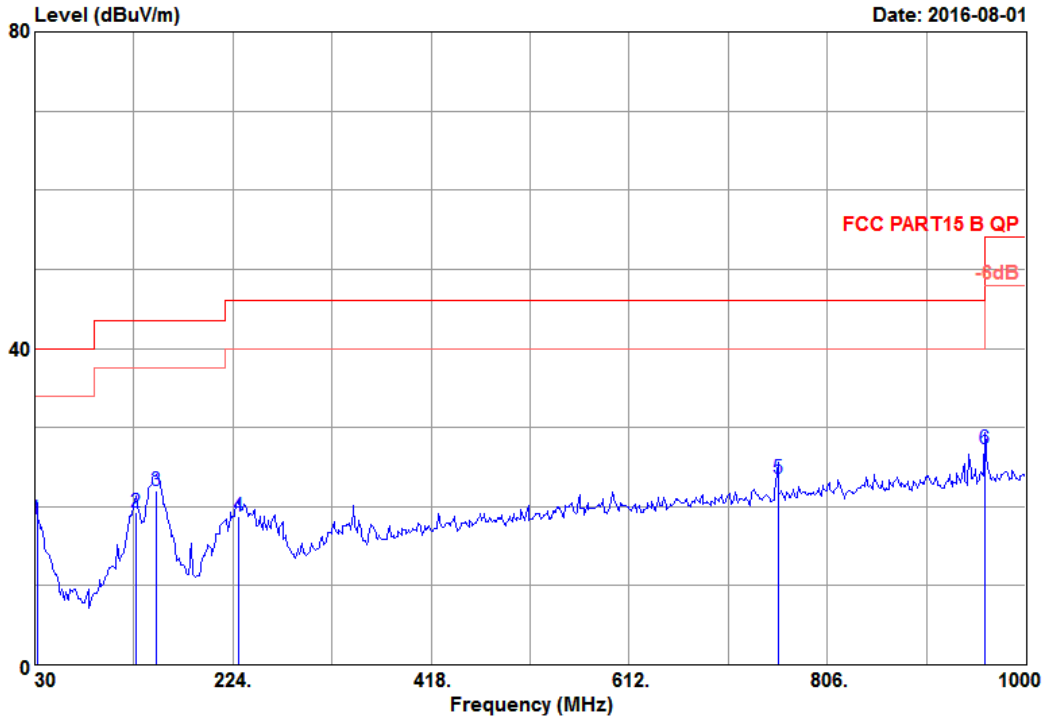

Site NO. : 3m chamber Data NO. :7
 Dis. / Ant. : 3m 6112D(22250)-1510 Ant. pol. : HORIZONTAL
 Limit : FCC PART15 B QP
 Env. / Ins. : 20.3*CS&42%/ESCI Engineer : Mickey
 EUT : LED lamp
 M/N : 9290011998A
 Power Rating : 120Vac/60Hz
 Test Mode : TX CH11 2405MHz
 Memo :

	Freq. (MHz)	Ant. Factor (dB/m)	Cable Loss (dB)	Reading (dBuV)	Emission Level (dBuV/m)	Limits (dBuV/m)	Margin (dB)	Remark
1	31.94	20.20	0.48	25.13	18.46	40.00	21.54	QP
2	128.94	13.16	0.98	32.20	19.25	43.50	24.25	QP
3	148.34	12.14	1.05	35.91	22.09	43.50	21.41	QP
4	229.82	11.50	1.36	32.72	18.84	46.00	27.16	QP
5	757.50	20.52	2.72	27.99	23.55	46.00	22.45	QP
6	960.23	22.12	3.22	29.04	27.36	54.00	26.64	QP

Remarks: 1. Emission Level= Antenna Factor + Cable Loss + Reading.
 2. The emission levels that are 20dB below the official limit are not reported.



Audix Technology(Wujiang)Co.,Ltd.
 No.1289,Jiang Xing East Road,The Eastern Part of Wu Jiang
 Economic Development Zone,JiangSu,China
 Tel: (0512) 63403993 Fax: (0512) 63403993

Data: 8 File: G:\Test Data\2016\Reports\08\G1608005R1.EM6 (26)

Date: 2016-08-01

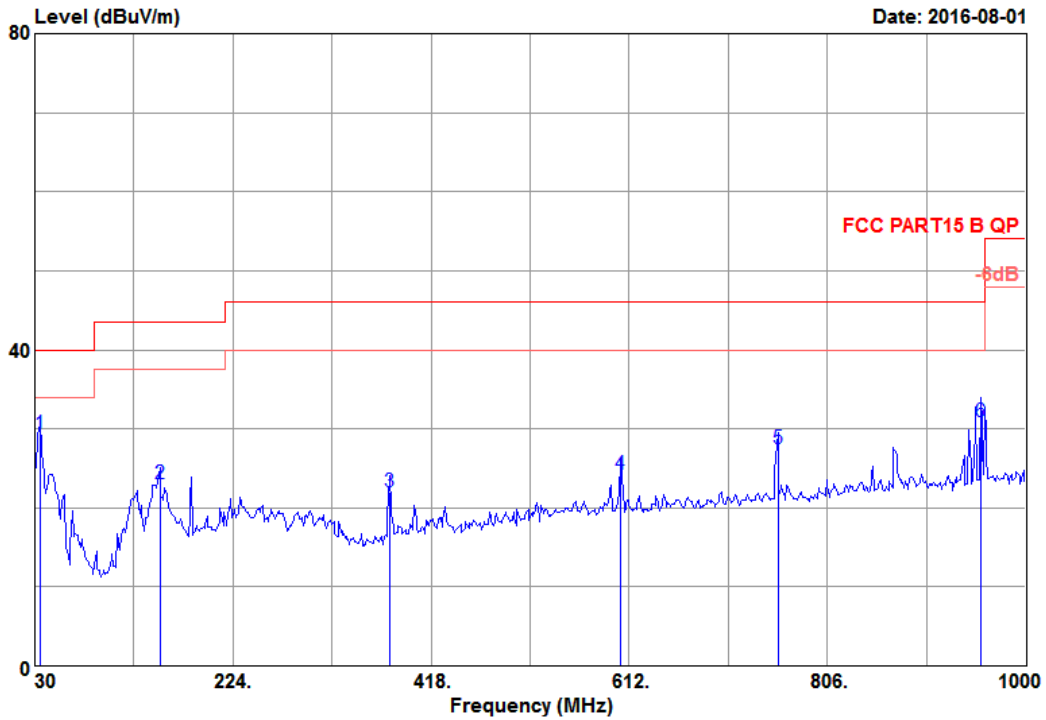

Site NO. : 3m chamber
 Dis. / Ant. : 3m 6112D(22250)-1510
 Limit : FCC PART15 B QP
 Env. / Ins. : 20.3*CS&42%/ESCI
 EUT : LED lamp
 M/N : 9290011998A
 Power Rating : 120Vac/60Hz
 Test Mode : TX CH11 2405MHz
 Memo :

Data NO. :8
 Ant. pol. : VERTICAL
 Engineer : Mickey

	Freq. (MHz)	Ant. Factor (dB/m)	Cable Loss (dB)	Reading (dBuV)	Emission Level (dBuV/m)	Limits (dBuV/m)	Margin (dB)	Remark
1	35.82	18.00	0.51	38.24	29.41	40.00	10.59	QP
2	152.22	11.76	1.07	37.27	23.11	43.50	20.39	QP
3	377.26	16.15	1.81	31.23	22.05	46.00	23.95	QP
4	603.27	19.51	2.38	30.35	24.25	46.00	21.75	QP
5	757.50	20.52	2.72	31.99	27.55	46.00	18.45	QP
6	956.35	22.09	3.21	32.67	30.94	46.00	15.06	QP

Remarks: 1. Emission Level= Antenna Factor + Cable Loss + Reading.
 2. The emission levels that are 20dB below the official limit are not reported.



Audix Technology(Wujiang)Co.,Ltd.
 No.1289,Jiang Xing East Road,The Eastern Part of Wu Jiang
 Economic Development Zone,JiangSu,China
 Tel:(0512)63403993 Fax:(0512)63403993

Data: 9 File: G:\Test Data\2016\Reports\08\G1608005R1.EM6 (26)

Date: 2016-08-01

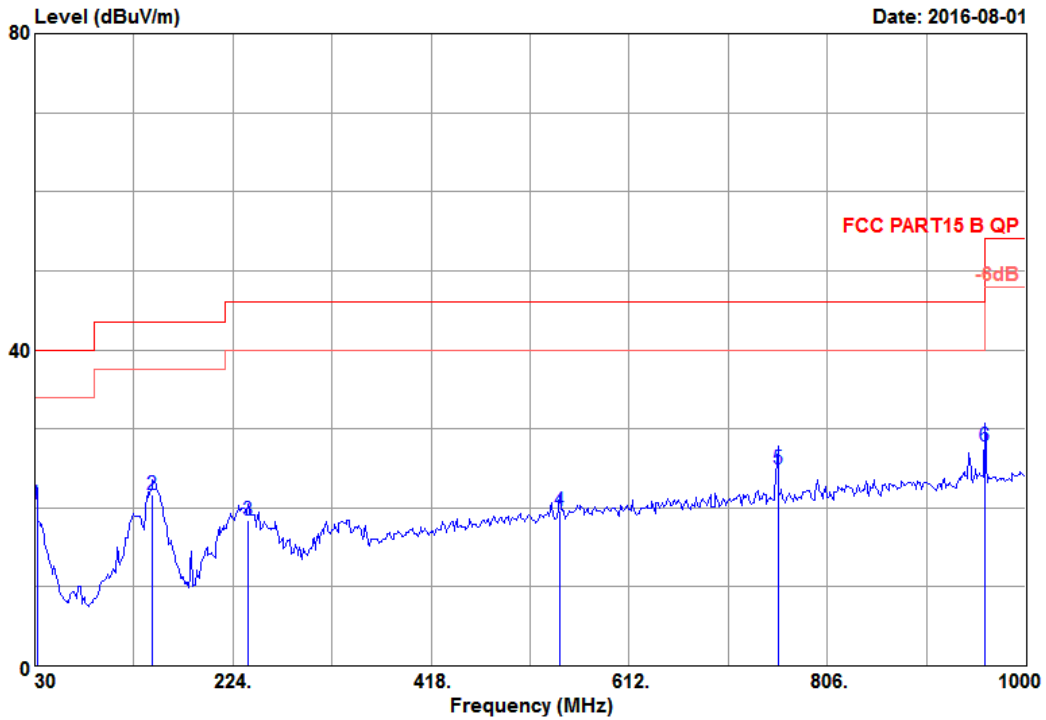

Site NO. : 3m chamber
 Dis. / Ant. : 3m 6112D(22250)-1510
 Limit : FCC PART15 B QP
 Env. / Ins. : 20.3*CS&42%/ESCI
 EUT : LED lamp
 M/N : 9290011998A
 Power Rating : 120Vac/60Hz
 Test Mode : TX CH20 2450MHz
 Memo :
 Data NO. : 9
 Ant. pol. : HORIZONTAL
 Engineer : Mickey

	Freq. (MHz)	Ant. Factor (dB/m)	Cable Loss (dB)	Reading (dBuV)	Emission Level (dBuV/m)	Limits (dBuV/m)	Margin (dB)	Remark
1	31.94	20.20	0.48	27.11	20.44	40.00	19.56	QP
2	145.43	12.43	1.04	35.15	21.60	43.50	21.90	QP
3	238.55	12.22	1.39	31.60	18.49	46.00	27.51	QP
4	544.10	18.77	2.23	26.50	19.56	46.00	26.44	QP
5	757.50	20.52	2.72	29.31	24.87	46.00	21.13	QP
6	960.23	22.12	3.22	29.43	27.75	54.00	26.25	QP

Remarks: 1. Emission Level= Antenna Factor + Cable Loss + Reading.
 2. The emission levels that are 20dB below the official limit are not reported.



Audix Technology(Wujiang)Co.,Ltd.
 No.1289,Jiang Xing East Road,The Eastern Part of Wu Jiang
 Economic Development Zone,JiangSu,China
 Tel: (0512) 63403993 Fax: (0512) 63403993

Data: 10 File: G:\Test Data\2016\Reports\08\G1608005R1.EM6 (26)

Date: 2016-08-01

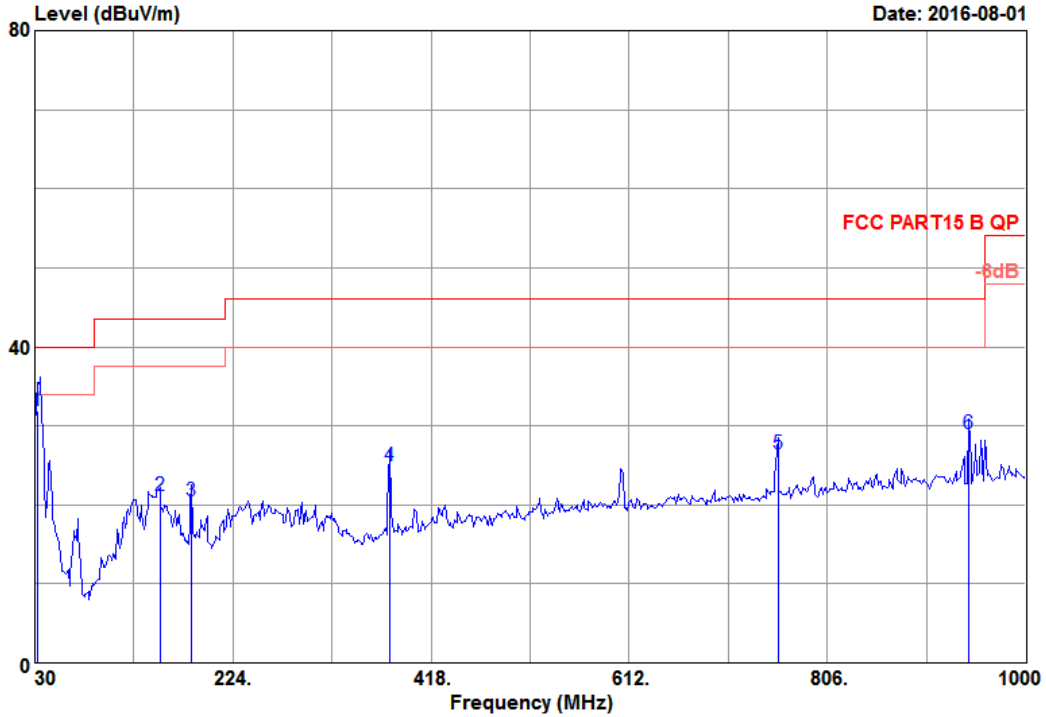

Site NO. : 3m chamber
 Dis. / Ant. : 3m 6112D(22250)-1510
 Limit : FCC PART15 B QP
 Env. / Ins. : 20.3*CS&42%/ESCI
 EUT : LED lamp
 M/N : 9290011998A
 Power Rating : 120Vac/60Hz
 Test Mode : TX CH20 2450MHz
 Memo :

Data NO. :10
 Ant. pol. : VERTICAL
 Engineer : Mickey

	Freq. (MHz)	Ant. Factor (dB/m)	Cable Loss (dB)	Reading (dBuV)	Emission Level (dBuV/m)	Limits (dBuV/m)	Margin (dB)	Remark
1	32.38	20.20	0.48	38.60	31.94	40.00	8.06	QP
2	152.22	11.76	1.07	35.35	21.19	43.50	22.31	QP
3	183.26	10.09	1.19	36.15	20.56	43.50	22.94	QP
4	377.26	16.15	1.81	34.07	24.89	46.00	21.11	QP
5	757.50	20.52	2.72	30.86	26.42	46.00	19.58	QP
6	944.71	22.01	3.17	30.81	28.93	46.00	17.07	QP

Remarks: 1. Emission Level= Antenna Factor + Cable Loss + Reading.
 2. The emission levels that are 20dB below the official limit are not reported.



Audix Technology(Wujiang)Co.,Ltd.
 No.1289,Jiang Xing East Road,The Eastern Part of Wu Jiang
 Economic Development Zone,JiangSu,China
 Tel: (0512) 63403993 Fax: (0512) 63403993

Data: 11 File: G:\Test Data\2016\Reports\08\G1608005R1.EM6 (26)

Date: 2016-08-01

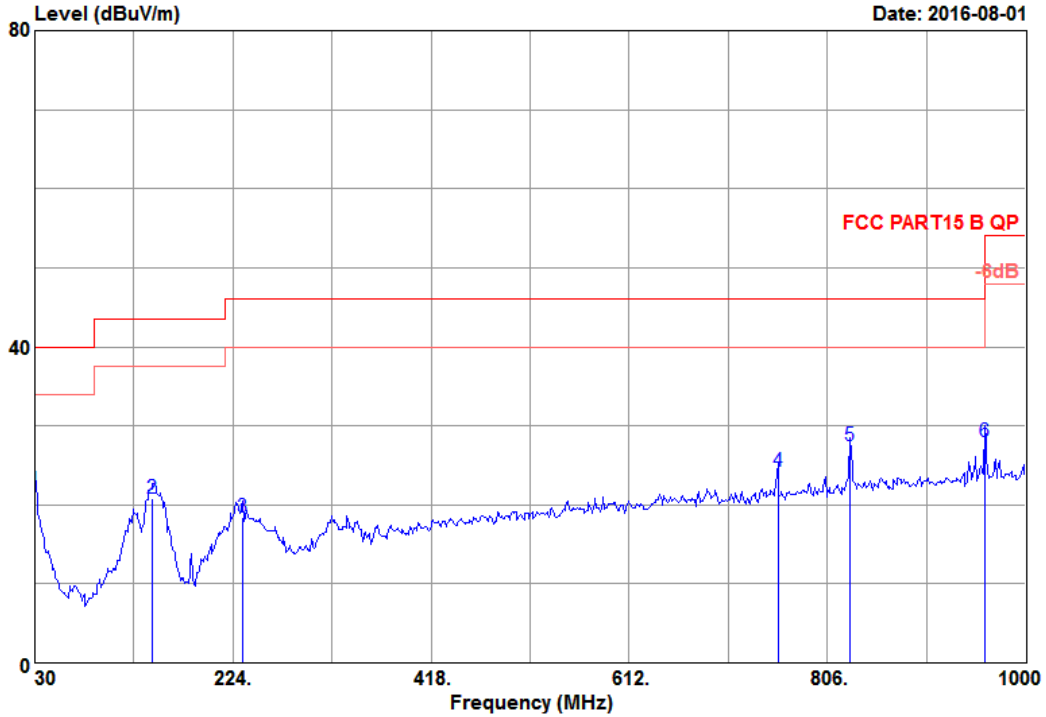

Site NO. : 3m chamber
 Dis. / Ant. : 3m 6112D(22250)-1510
 Limit : FCC PART15 B QP
 Env. / Ins. : 20.3°C&42%/ESCI
 EUT : LED lamp
 M/N : 9290011998A
 Power Rating : 120Vac/60Hz
 Test Mode : TX CH26 2480MHz
 Memo :
 Data NO. :11
 Ant. pol. : HORIZONTAL
 Engineer : Mickey

	Freq. (MHz)	Ant. Factor (dB/m)	Cable Loss (dB)	Reading (dBuV)	Emission Level (dBuV/m)	Limits (dBuV/m)	Margin (dB)	Remark
1	30.00	21.30	0.47	27.45	21.87	40.00	18.13	QP
2	145.43	12.43	1.04	34.32	20.77	43.50	22.73	QP
3	233.70	11.82	1.37	32.02	18.48	46.00	27.52	QP
4	757.50	20.52	2.72	28.68	24.24	46.00	21.76	QP
5	828.31	21.13	2.88	30.95	27.47	46.00	18.53	QP
6	960.23	22.12	3.22	29.64	27.96	54.00	26.04	QP

Remarks: 1. Emission Level= Antenna Factor + Cable Loss + Reading.
 2. The emission levels that are 20dB below the official limit are not reported.



Audix Technology(Wujiang)Co.,Ltd.
 No.1289,Jiang Xing East Road,The Eastern Part of Wu Jiang
 Economic Development Zone,JiangSu,China
 Tel: (0512) 63403993 Fax: (0512) 63403993

Data: 12 File: G:\Test Data\2016\Reports\08\G1608005R1.EM6 (26)

Date: 2016-08-01

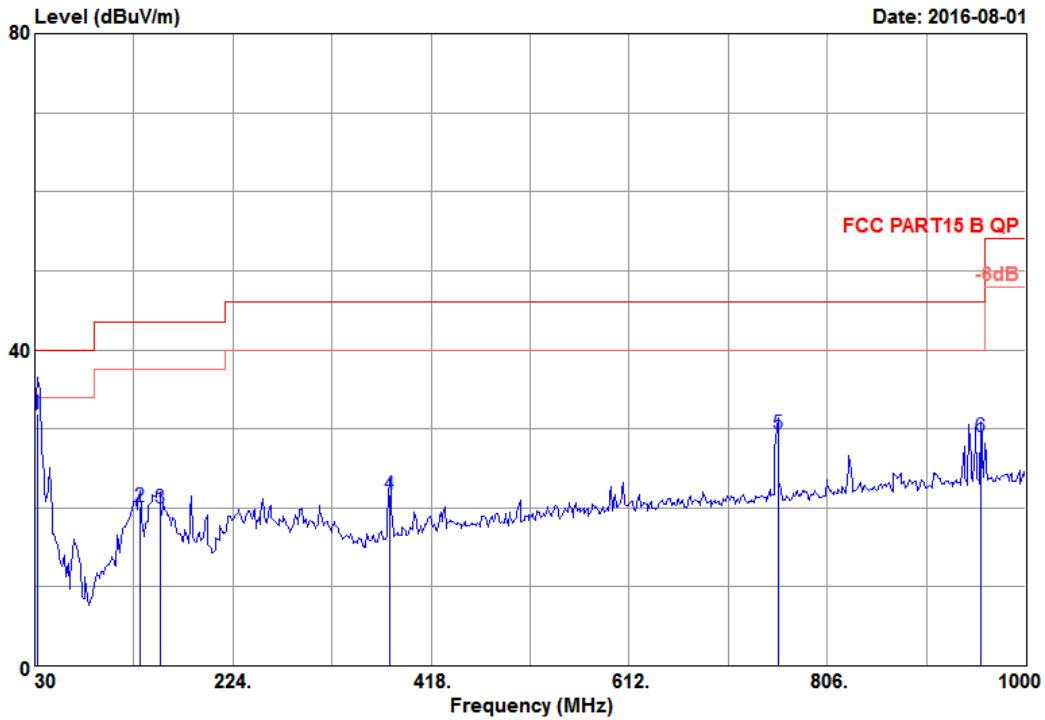

Site NO. : 3m chamber
 Dis. / Ant. : 3m 6112D(22250)-1510
 Limit : FCC PART15 B QP
 Env. / Ins. : 20.3*CS&42%/ESCI
 EUT : LED lamp
 M/N : 9290011998A
 Power Rating : 120Vac/60Hz
 Test Mode : TX CH26 2480MHz
 Memo :

Data NO. :12
 Ant. pol. : VERTICAL
 Engineer : Mickey

	Freq. (MHz)	Ant. Factor (dB/m)	Cable Loss (dB)	Reading (dBuV)	Emission Level (dBuV/m)	Limits (dBuV/m)	Margin (dB)	Remark
1	32.40	20.20	0.48	38.50	31.84	40.00	8.16	QP
2	132.82	13.11	0.99	33.10	20.13	43.50	23.37	QP
3	152.22	11.76	1.07	34.14	19.98	43.50	23.52	QP
4	377.26	16.15	1.81	30.90	21.72	46.00	24.28	QP
5	757.50	20.52	2.72	33.85	29.41	46.00	16.59	QP
6	956.35	22.09	3.21	30.67	28.94	46.00	17.06	QP

Remarks: 1. Emission Level= Antenna Factor + Cable Loss + Reading.
 2. The emission levels that are 20dB below the official limit are not reported.

5.7. Restricted Bands Measurement Results (For Above 1GHz)



Audix Technology(Wujiang) Co.,Ltd.
 No.1289,Jiang Xing East Road,The Eastern Part of Wu Jiang
 Economic Development Zone,JiangSu,China
 Tel: (0512) 63403993 Fax: (0512) 63403993

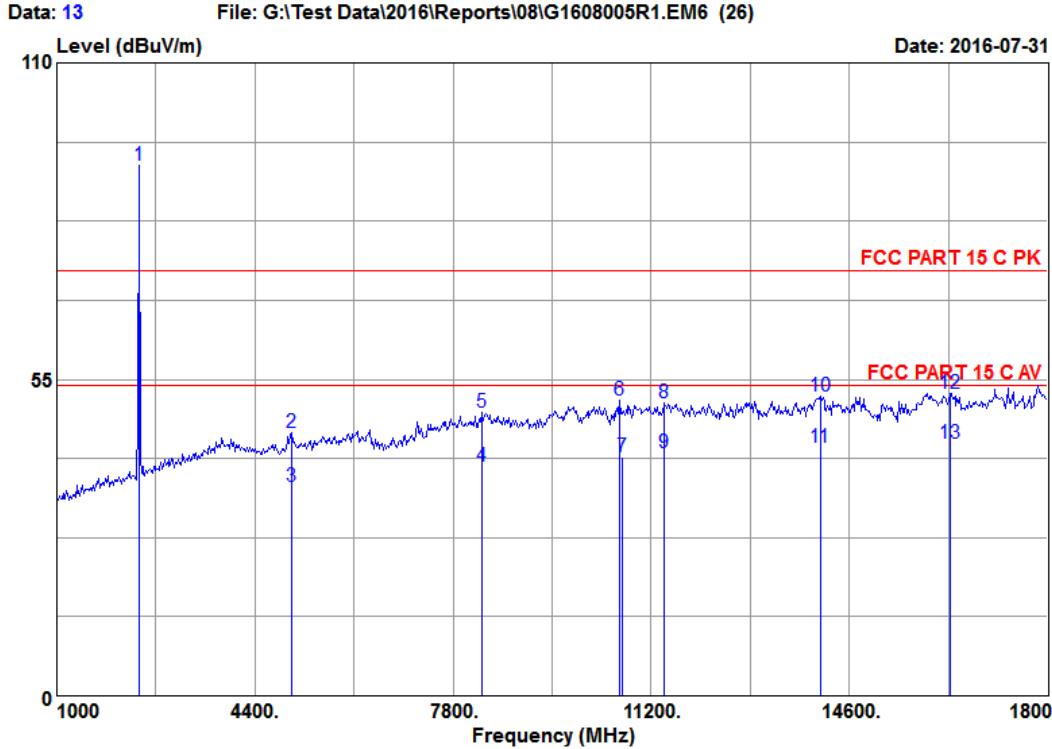

Site NO. : 3m Semi-Anechoic Chamber Data NO. : 13
 Dis. / Ant. : 3m 3115-62961 1509 Ant. pol. : HORIZONTAL
 Limit : FCC PART 15 C PK
 Env. / Ins. : 20.3*C&42%/N9030A Engineer : Mickey
 EUT : LED Lamp
 M/N : 9290011998A
 Power Rating: 120Vac/60Hz
 Test Mode : TX CH11 2405MHz
 Memo :

	Freq. (MHz)	Ant. Factor (dB)	Cable Loss (dB)	Reading (dBuV)	Preamp Factor (dB)	Emission Level (dBuV/m)	Limits (dBuV/m)	Margin (dB)	Remark
1	2407.00	28.11	5.09	93.53	34.50	92.23	74.00	-18.23	Peak
2	5032.00	33.26	7.45	38.85	33.92	45.64	74.00	28.36	Peak
3	5035.85	33.26	7.45	29.65	33.92	36.44	54.00	17.56	Average
4	8285.45	37.15	9.70	27.16	34.20	39.81	54.00	14.19	Average
5	8287.00	37.15	9.70	36.63	34.20	49.28	74.00	24.72	Peak
6	10660.00	39.00	11.18	35.08	33.92	51.34	74.00	22.66	Peak
7	10695.26	39.00	11.19	25.15	33.90	41.44	54.00	12.56	Average
8	11416.00	39.25	11.41	34.06	33.71	51.01	74.00	22.99	Peak
9	11417.25	39.25	11.41	25.28	33.71	42.23	54.00	11.77	Average
10	14104.00	41.70	12.88	29.34	31.73	52.19	74.00	21.81	Peak
11	14105.27	41.70	12.88	20.27	31.73	43.12	54.00	10.88	Average
12	16330.00	38.13	14.29	33.76	33.59	52.59	74.00	21.41	Peak
13	16335.28	38.13	14.29	25.15	33.59	43.98	54.00	10.02	Average

Remarks: 1. Emission Level= Ant.Factor + Cable Loss + Reading - Preamp.Factor.
 2. The emission levels that are 20dB below the official limit are not reported.



Audix Technology(Wujiang)Co.,Ltd.
 No.1289,Jiang Xing East Road,The Eastern Part of Wu Jiang
 Economic Development Zone,JiangSu,China
 Tel: (0512) 63403993 Fax: (0512) 63403993

Data: 14 File: G:\Test Data\2016\Reports\08\G1608005R1.EM6 (26)

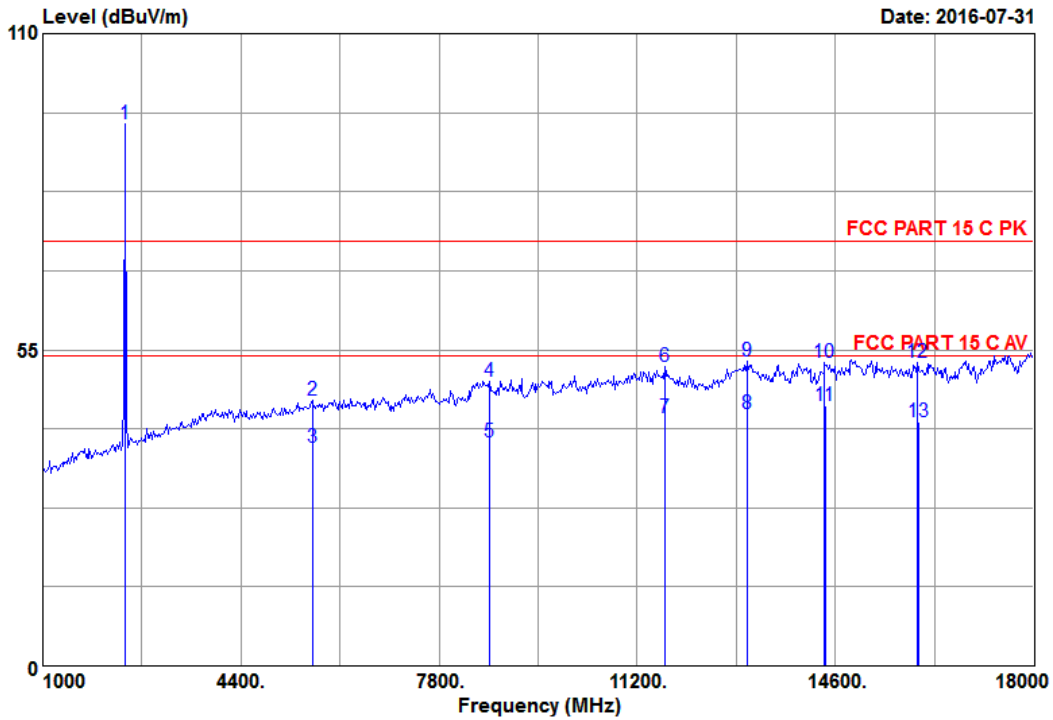

Site NO. : 3m Semi-Anechoic Chamber
 Dis. / Ant. : 3m 3115-62961 1509
 Limit : FCC PART 15 C PK
 Env. / Ins. : 20.3*C&42%/N9030A
 EUT : LED Lamp
 M/N : 9290011998A
 Power Rating: 120Vac/60Hz
 Test Mode : TX CH11 2405MHz
 Memo :

Data NO. : 14
 Ant. pol. : VERTICAL
 Engineer : Mickey

Freq. (MHz)	Ant. Factor (dB)	Cable Loss (dB)	Reading (dBuV)	Preamp Factor (dB)	Emission Level (dBuV/m)	Limits (dBuV/m)	Margin (dB)	Remark
1 2407.00	28.11	5.09	95.59	34.50	94.29	74.00	-20.29	Peak
2 5620.00	34.17	8.12	37.74	33.90	46.13	74.00	27.87	Peak
3 5625.85	34.17	8.12	29.72	33.90	38.11	54.00	15.89	Average
4 8665.00	37.57	9.86	36.45	34.32	49.56	74.00	24.44	Peak
5 8670.29	37.57	9.86	25.74	34.32	38.85	54.00	15.15	Average
6 11668.00	39.40	11.45	35.03	33.75	52.13	74.00	21.87	Peak
7 11670.28	39.40	11.45	25.95	33.75	43.05	54.00	10.95	Average
8 13095.03	39.84	12.35	24.17	32.39	43.97	54.00	10.03	Average
9 13096.00	39.87	12.35	33.07	32.39	52.90	74.00	21.10	Peak
10 14419.00	42.01	12.98	30.00	32.17	52.82	74.00	21.18	Peak
11 14425.35	42.03	12.98	22.45	32.17	45.29	54.00	8.71	Average
12 16015.00	37.63	14.46	34.69	33.95	52.83	74.00	21.17	Peak
13 16020.45	37.65	14.46	24.28	33.95	42.44	54.00	11.56	Average

Remarks: 1. Emission Level= Ant.Factor + Cable Loss + Reading - Preamp.Factor.
 2. The emission levels that are 20dB below the official limit are not reported.



Audix Technology(Wujiang)Co.,Ltd.
 No.1289,Jiang Xing East Road,The Eastern Part of Wu Jiang
 Economic Development Zone,JiangSu,China
 Tel: (0512) 63403993 Fax: (0512) 63403993

Data: 15 File: G:\Test Data\2016\Reports\08\G1608005R1.EM6 (26)

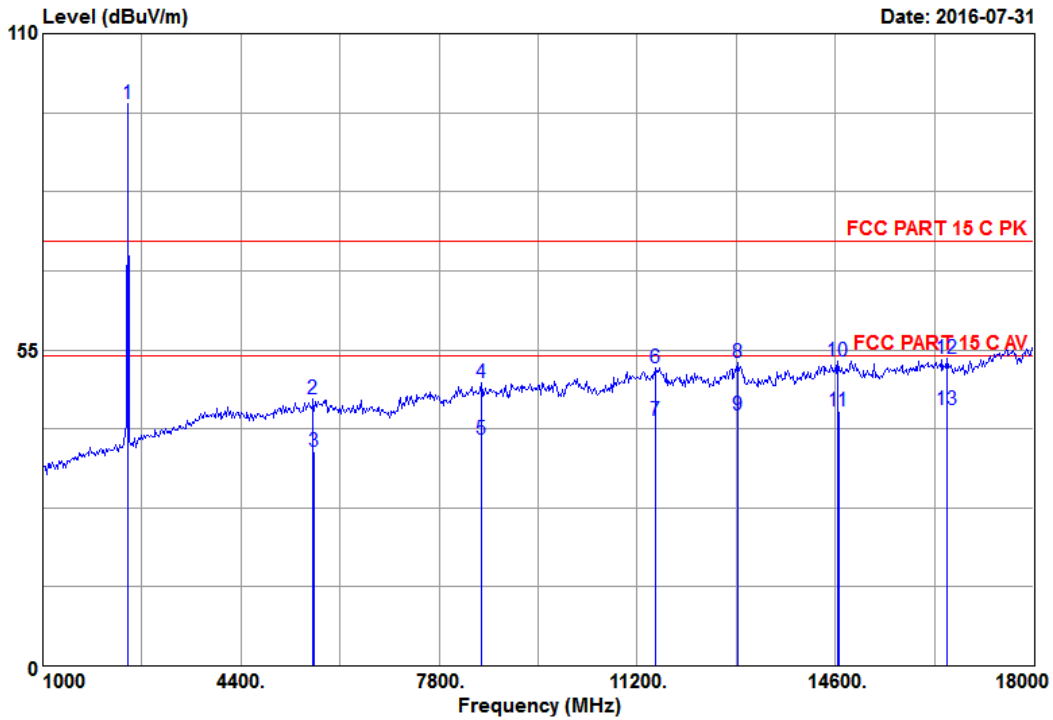

Site NO. : 3m Semi-Anechoic Chamber Data NO. : 15
 Dis. / Ant. : 3m 3115-62961 1509 Ant. pol. : HORIZONTAL
 Limit : FCC PART 15 C PK
 Env. / Ins. : 20.3*C&42%/N9030A Engineer : Mickey
 EUT : LED Lamp
 M/N : 9290011998A
 Power Rating: 120Vac/60Hz
 Test Mode : TX CH20 2450MHz
 Memo :

Freq. (MHz)	Ant. Factor (dB)	Cable Loss (dB)	Reading (dBuV)	Preamp Factor (dB)	Emission Level (dBuV/m)	Limits (dBuV/m)	Margin (dB)	Remark
1 2449.00	28.19	5.15	99.00	34.50	97.84	74.00	-23.84	Peak
2 5641.00	34.18	8.14	38.13	33.90	46.55	74.00	27.45	Peak
3 5645.35	34.18	8.14	28.86	33.90	37.28	54.00	16.72	Average
4 8518.00	37.42	9.80	36.21	34.27	49.16	74.00	24.84	Peak
5 8520.25	37.42	9.80	26.44	34.27	39.39	54.00	14.61	Average
6 11521.00	39.31	11.43	34.79	33.73	51.80	74.00	22.20	Peak
7 11525.25	39.31	11.43	25.75	33.73	42.76	54.00	11.24	Average
8 12928.00	39.61	12.25	33.43	32.56	52.73	74.00	21.27	Peak
9 12930.60	39.61	12.25	24.25	32.56	43.55	54.00	10.45	Average
10 14650.00	41.62	13.06	30.82	32.49	53.01	74.00	20.99	Peak
11 14655.45	41.62	13.06	22.15	32.53	44.30	54.00	9.70	Average
12 16519.00	38.48	14.17	34.16	33.36	53.45	74.00	20.55	Peak
13 16520.15	38.48	14.17	25.25	33.36	44.54	54.00	9.46	Average

Remarks: 1. Emission Level= Ant.Factor + Cable Loss + Reading - Preamp.Factor.
 2. The emission levels that are 20dB below the official limit are not reported.



Audix Technology(Wujiang)Co.,Ltd.
 No.1289,Jiang Xing East Road,The Eastern Part of Wu Jiang
 Economic Development Zone,JiangSu,China
 Tel: (0512) 63403993 Fax: (0512) 63403993

Data: 16 File: G:\Test Data\2016\Reports\08\G1608005R1.EM6 (26)

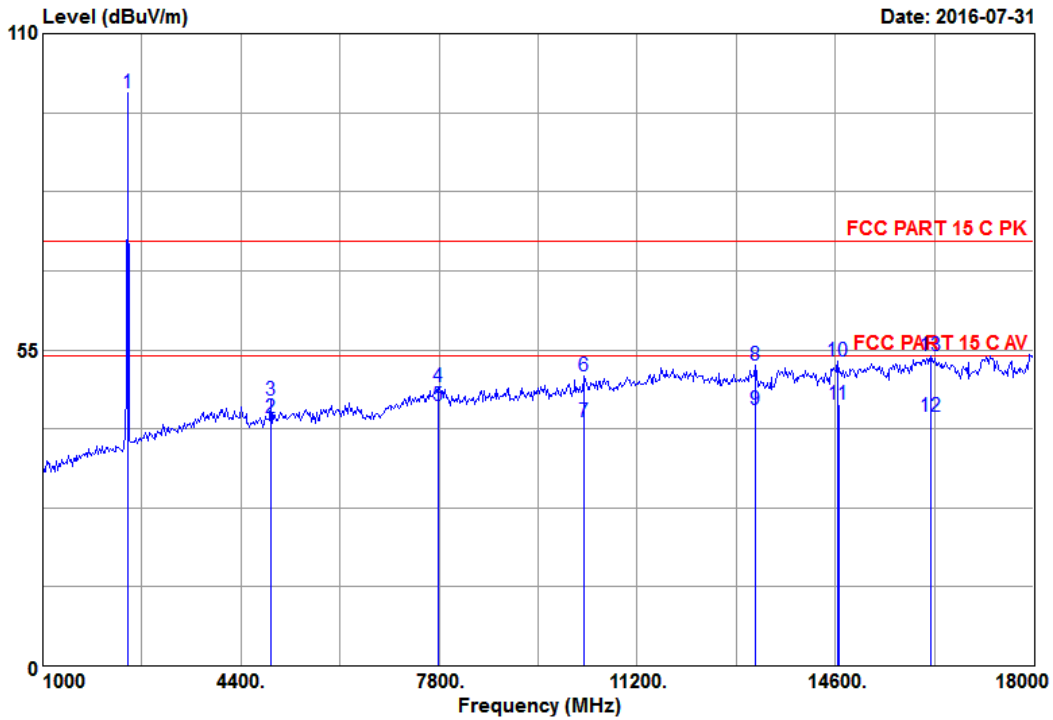

Site NO. : 3m Semi-Anechoic Chamber Data NO. : 16
 Dis. / Ant. : 3m 3115-62961 1509 Ant. pol. : VERTICAL
 Limit : FCC PART 15 C PK
 Env. / Ins. : 20.3*C&42%/N9030A Engineer : Mickey
 EUT : LED Lamp
 M/N : 9290011998A
 Power Rating: 120Vac/60Hz
 Test Mode : TX CH20 2450MHz
 Memo :

	Freq. (MHz)	Ant. Factor (dB)	Cable Loss (dB)	Reading (dBuV)	Preamp Factor (dB)	Emission Level (dBuV/m)	Limits (dBuV/m)	Margin (dB)	Remark
1	2449.00	28.19	5.15	100.74	34.50	99.58	74.00	-25.58	Peak
2	4905.26	33.04	7.37	36.76	33.94	43.23	54.00	10.77	Average
3	4906.00	33.04	7.37	39.74	33.94	46.21	74.00	27.79	Peak
4	7783.00	36.71	9.42	36.43	34.09	48.47	74.00	25.53	Peak
5	7785.25	36.71	9.42	33.15	34.09	45.19	54.00	8.81	Average
6	10282.00	38.96	10.99	34.79	34.24	50.50	74.00	23.50	Peak
7	10285.35	38.96	10.99	26.75	34.24	42.46	54.00	11.54	Average
8	13222.00	40.06	12.42	32.07	32.28	52.27	74.00	21.73	Peak
9	13225.30	40.06	12.42	24.28	32.28	44.48	54.00	9.52	Average
10	14650.00	41.62	13.06	30.83	32.49	53.02	74.00	20.98	Peak
11	14655.27	41.62	13.06	23.29	32.53	45.44	54.00	8.56	Average
12	16245.85	38.00	14.33	24.87	33.68	43.52	54.00	10.48	Average
13	16246.00	38.00	14.33	35.26	33.68	53.91	74.00	20.09	Peak

Remarks: 1. Emission Level= Ant.Factor + Cable Loss + Reading - Preamp.Factor.
 2. The emission levels that are 20dB below the official limit are not reported.



Audix Technology(Wujiang)Co.,Ltd.
 No.1289,Jiang Xing East Road,The Eastern Part of Wu Jiang
 Economic Development Zone,JiangSu,China
 Tel: (0512) 63403993 Fax: (0512) 63403993

Data: 17 File: G:\Test Data\2016\Reports\08\G1608005R1.EM6 (26)

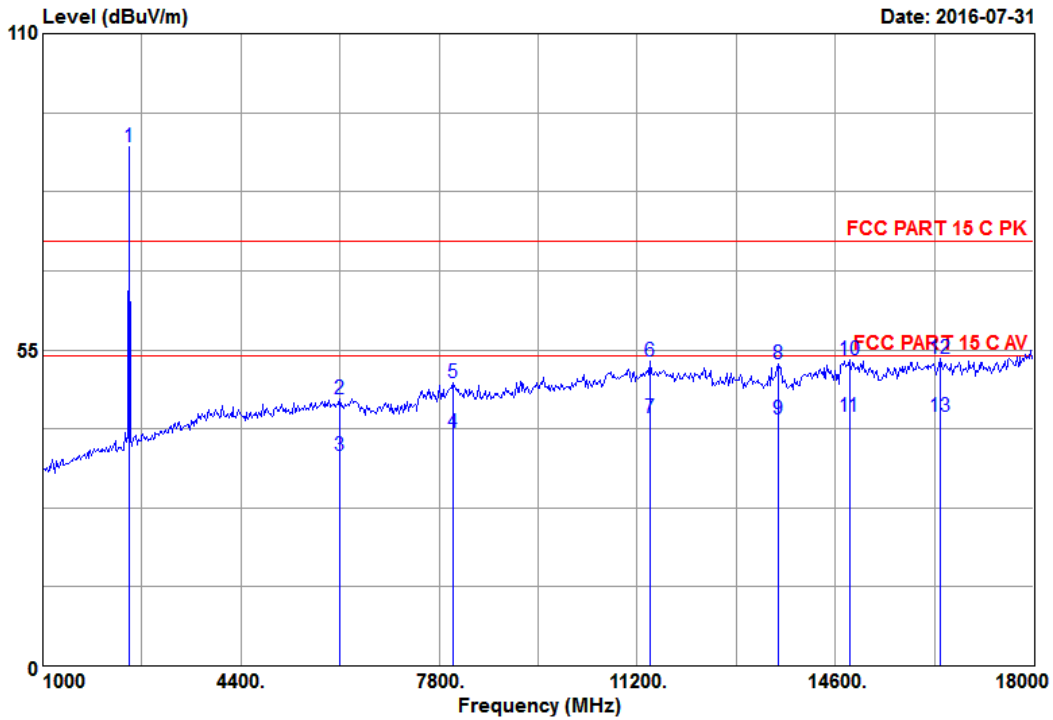

Site NO. : 3m Semi-Anechoic Chamber Data NO. : 17
 Dis. / Ant. : 3m 3115-62961 1509 Ant. pol. : HORIZONTAL
 Limit : FCC PART 15 C PK
 Env. / Ins. : 20.3*CS&42%/N9030A Engineer : Mickey
 EUT : LED Lamp
 M/N : 9290011998A
 Power Rating: 120Vac/60Hz
 Test Mode : TX CH26 2480MHz
 Memo :

	Freq. (MHz)	Ant. Factor (dB)	Cable Loss (dB)	Reading (dBuV)	Preamp Factor (dB)	Emission Level (dBuV/m)	Limits (dBuV/m)	Margin (dB)	Remark
1	2470.00	28.22	5.18	91.30	34.49	90.21	74.00	-16.21	Peak
2	6103.00	34.42	8.58	37.34	33.90	46.44	74.00	27.56	Peak
3	6105.28	34.42	8.58	27.48	33.90	36.58	54.00	17.42	Average
4	8030.49	36.84	9.60	28.25	34.12	40.57	54.00	13.43	Average
5	8035.00	36.84	9.60	36.99	34.12	49.31	74.00	24.69	Peak
6	11416.00	39.25	11.41	36.00	33.71	52.95	74.00	21.05	Peak
7	11420.35	39.25	11.41	26.25	33.71	43.20	54.00	10.80	Average
8	13621.00	40.76	12.64	31.17	31.92	52.65	74.00	21.35	Peak
9	13625.80	40.79	12.64	21.45	31.92	42.96	54.00	11.04	Average
10	14839.00	41.03	13.12	31.95	32.78	53.32	74.00	20.68	Peak
11	14841.65	41.03	13.12	21.95	32.78	43.32	54.00	10.68	Average
12	16393.00	38.21	14.24	34.45	33.50	53.40	74.00	20.60	Peak
13	16395.85	38.24	14.24	24.45	33.50	43.43	54.00	10.57	Average

Remarks: 1. Emission Level= Ant.Factor + Cable Loss + Reading - Preamp.Factor.
 2. The emission levels that are 20dB below the official limit are not reported.



Audix Technology(Wujiang)Co.,Ltd.
 No.1289,Jiang Xing East Road,The Eastern Part of Wu Jiang
 Economic Development Zone,JiangSu,China
 Tel: (0512) 63403993 Fax: (0512) 63403993

Data: 18 File: G:\Test Data\2016\Reports\08\G1608005R1.EM6 (26)

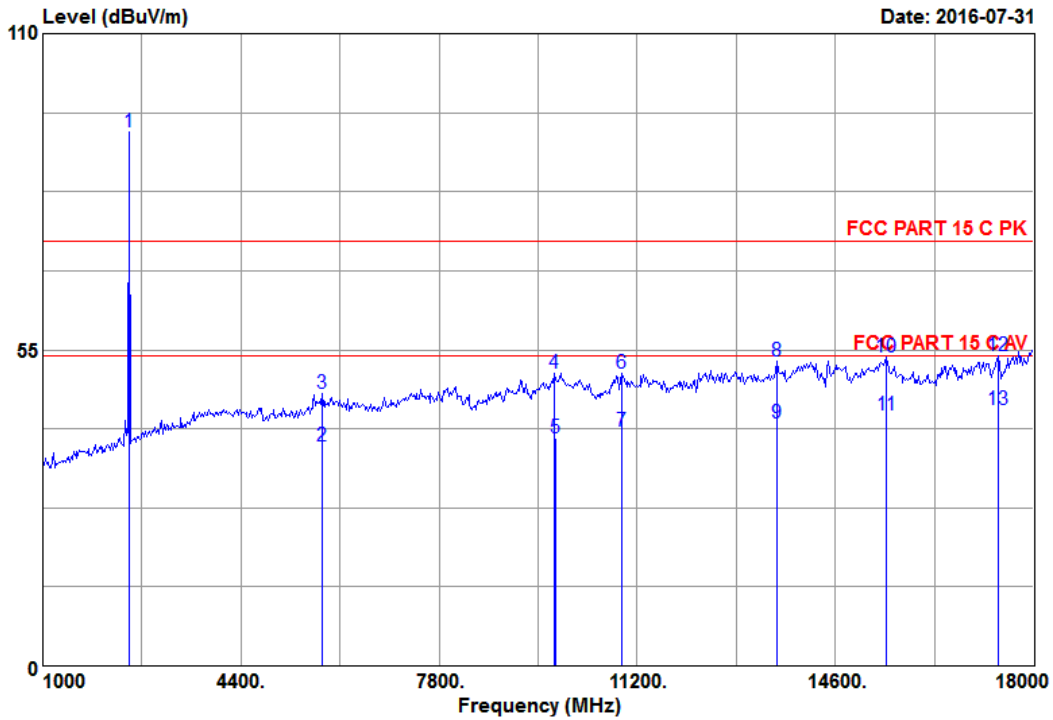

Site NO. : 3m Semi-Anechoic Chamber Data NO. : 18
 Dis. / Ant. : 3m 3115-62961 1509 Ant. pol. : VERTICAL
 Limit : FCC PART 15 C PK
 Env. / Ins. : 20.3*C&42%/N9030A Engineer : Mickey
 EUT : LED Lamp
 M/N : 9290011998A
 Power Rating: 120Vac/60Hz
 Test Mode : TX CH26 2480MHz
 Memo :

Freq. (MHz)	Ant. Factor (dB)	Cable Loss (dB)	Reading (dBuV)	Preamp Factor (dB)	Emission Level (dBuV/m)	Limits (dBuV/m)	Margin (dB)	Remark
1 2470.00	28.22	5.18	94.04	34.49	92.95	74.00	-18.95	Peak
2 5785.25	34.27	8.32	29.65	33.90	38.34	54.00	15.66	Average
3 5788.00	34.28	8.32	38.78	33.90	47.48	74.00	26.52	Peak
4 9778.00	38.59	10.65	36.02	34.46	50.80	74.00	23.20	Peak
5 9790.25	38.61	10.67	24.85	34.46	39.67	54.00	14.33	Average
6 10933.00	39.00	11.31	34.25	33.68	50.88	74.00	23.12	Peak
7 10935.25	39.00	11.31	24.29	33.68	40.92	54.00	13.08	Average
8 13600.00	40.72	12.63	31.57	31.95	52.97	74.00	21.03	Peak
9 13600.15	40.72	12.63	20.85	31.95	42.25	54.00	11.75	Average
10 15469.00	38.08	13.77	35.28	33.45	53.68	74.00	20.32	Peak
11 15475.25	38.08	13.80	25.27	33.48	43.67	54.00	10.33	Average
12 17401.00	43.40	13.86	29.45	32.86	53.85	74.00	20.15	Peak
13 17405.35	43.40	13.86	20.25	32.86	44.65	54.00	9.35	Average

Remarks: 1. Emission Level= Ant.Factor + Cable Loss + Reading - Preamp.Factor.
 2. The emission levels that are 20dB below the official limit are not reported.

5.8. Spurious Emission Measurement Results in Band Edge Emission (FCC Part 15, 15.205)



Audix Technology(Wujiang) Co., Ltd.
 No.1289, Jiang Xing East Road, The Eastern Part of Wu Jiang
 Economic Development Zone, JiangSu, China
 Tel: (0512) 63403993 Fax: (0512) 63403993

Data: 19 File: G:\Test Data\2016\Reports\08\G1608005R1.EM6 (26)

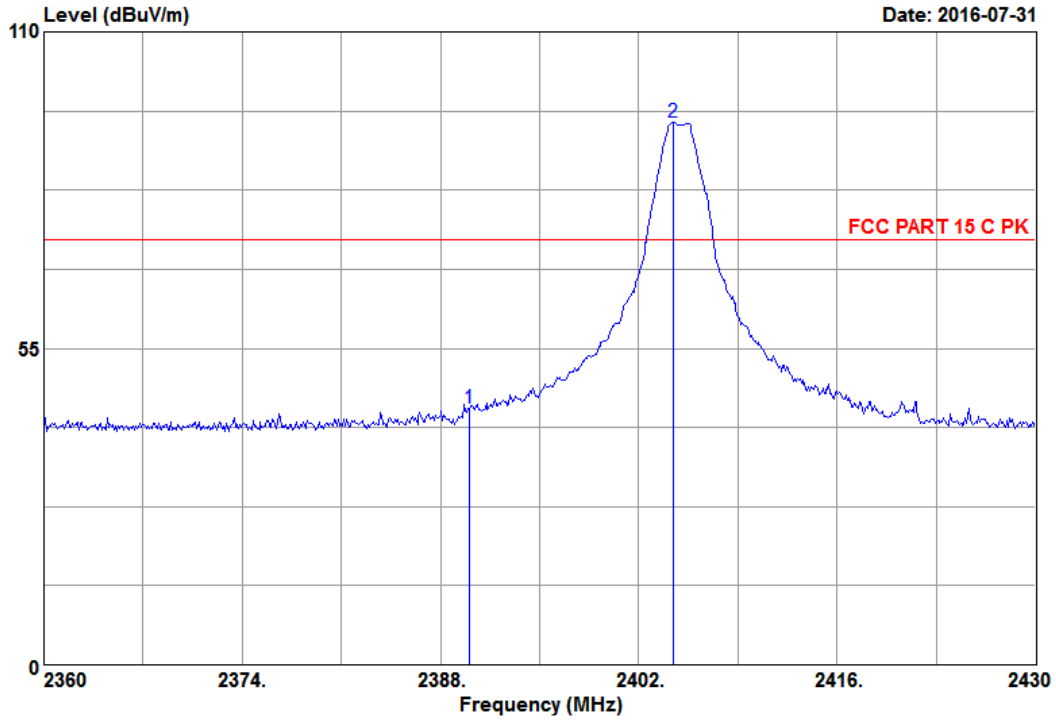

Site NO. : 3m Semi-Anechoic Chamber Data NO. : 19
 Dis. / Ant. : 3m 3115-62961 1509 Ant. pol. : HORIZONTAL
 Limit : FCC PART 15 C PK
 Env. / Ins. : 20.3*CS&42%/N9030A Engineer : Mickey
 EUT : LED Lamp
 M/N : 9290011998A
 Power Rating: 120Vac/60Hz
 Test Mode : TX CH11 2405MHz
 Memo :

	Freq. (MHz)	Ant. Factor (dB)	Cable Loss (dB)	Reading (dBuV)	Preamp Factor (dB)	Emission Level (dBuV/m)	Limits (dBuV/m)	Margin (dB)	Remark
1	2390.00	28.07	5.09	45.93	34.50	44.59	74.00	29.41	Peak
2	2404.46	28.11	5.09	95.67	34.50	94.37	74.00	-20.37	Peak

Remarks: 1. Emission Level= Ant.Factor + Cable Loss + Reading - Preamp.Factor.
 2. The emission levels that are 20dB below the official limit are not reported.



Audix Technology(Wujiang)Co.,Ltd.
 No.1289,Jiang Xing East Road,The Eastern Part of Wu Jiang
 Economic Development Zone,JiangSu,China
 Tel: (0512) 63403993 Fax: (0512) 63403993

Data: 20 File: G:\Test Data\2016\Reports\08\G1608005R1.EM6 (26)

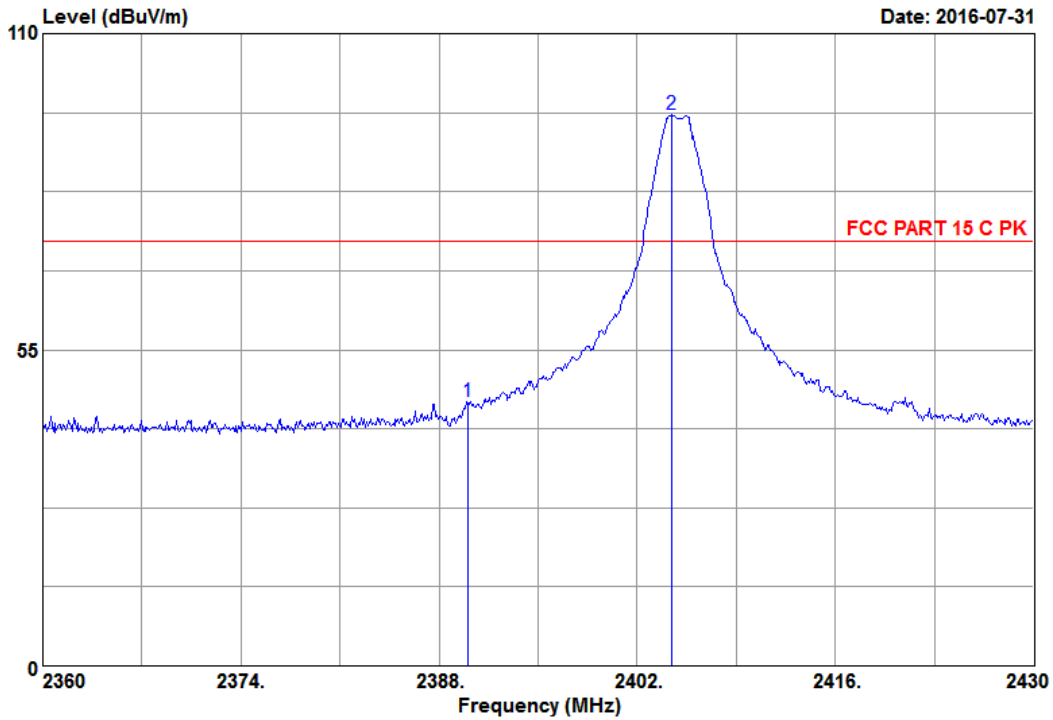

Site NO. : 3m Semi-Anechoic Chamber
 Dis. / Ant. : 3m 3115-62961 1509
 Limit : FCC PART 15 C PK
 Env. / Ins. : 20.3*CS&42%/N9030A
 EUT : LED Lamp
 M/N : 9290011998A
 Power Rating: 120Vac/60Hz
 Test Mode : TX CH11 2405MHz
 Memo :
 Data NO. : 20
 Ant. pol. : VERTICAL
 Engineer : Mickey

	Freq. (MHz)	Ant. Factor (dB)	Cable Loss (dB)	Reading (dBuV)	Preamp Factor (dB)	Emission Level (dBuV/m)	Limits (dBuV/m)	Margin (dB)	Remark
1	2390.00	28.07	5.09	47.40	34.50	46.06	74.00	27.94	Peak
2	2404.46	28.11	5.09	97.19	34.50	95.89	74.00	-21.89	Peak

Remarks: 1. Emission Level= Ant.Factor + Cable Loss + Reading - Preamp.Factor.
 2. The emission levels that are 20dB below the official limit are not reported.



Audix Technology(Wujiang)Co.,Ltd.
 No.1289,Jiang Xing East Road,The Eastern Part of Wu Jiang
 Economic Development Zone,JiangSu,China
 Tel: (0512) 63403993 Fax: (0512) 63403993

Data: 21 File: G:\Test Data\2016\Reports\08\G1608005R1.EM6 (26)

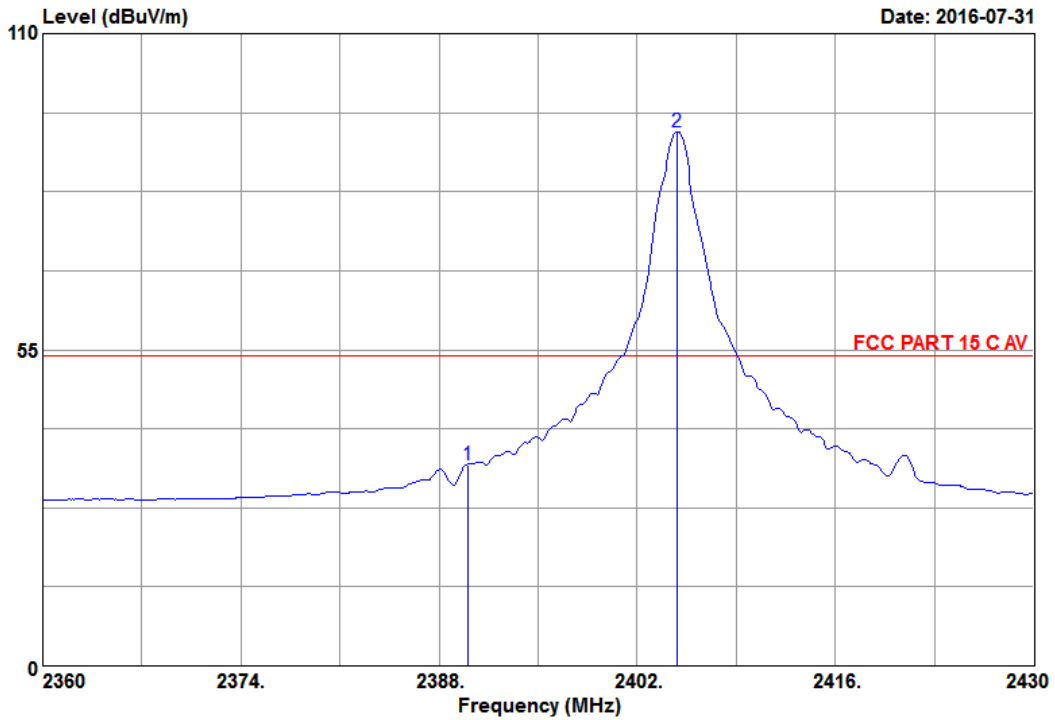

Site NO. : 3m Semi-Anechoic Chamber Data NO. : 21
 Dis. / Ant. : 3m 3115-62961 1509 Ant. pol. : HORIZONTAL
 Limit : FCC PART 15 C AV
 Env. / Ins. : 20.3*CS&42%/N9030A Engineer : Mickey
 EUT : LED Lamp
 M/N : 9290011998A
 Power Rating: 120Vac/60Hz
 Test Mode : TX CH11 2405MHz
 Memo :

	Freq. (MHz)	Ant. Factor (dB)	Cable Loss (dB)	Reading (dBuV)	Preamp Factor (dB)	Emission Level (dBuV/m)	Limits (dBuV/m)	Margin (dB)	Remark
1	2390.00	28.07	5.09	36.40	34.50	35.06	54.00	18.94	Average
2	2404.82	28.11	5.09	94.18	34.50	92.88	54.00	-38.88	Average

Remarks: 1. Emission Level= Ant.Factor + Cable Loss + Reading - Preamp.Factor.
 2. The emission levels that are 20dB below the official limit are not reported.



Audix Technology(Wujiang)Co.,Ltd.
 No.1289,Jiang Xing East Road,The Eastern Part of Wu Jiang
 Economic Development Zone,JiangSu,China
 Tel: (0512) 63403993 Fax: (0512) 63403993

Data: 22 File: G:\Test Data\2016\Reports\08\G1608005R1.EM6 (26)

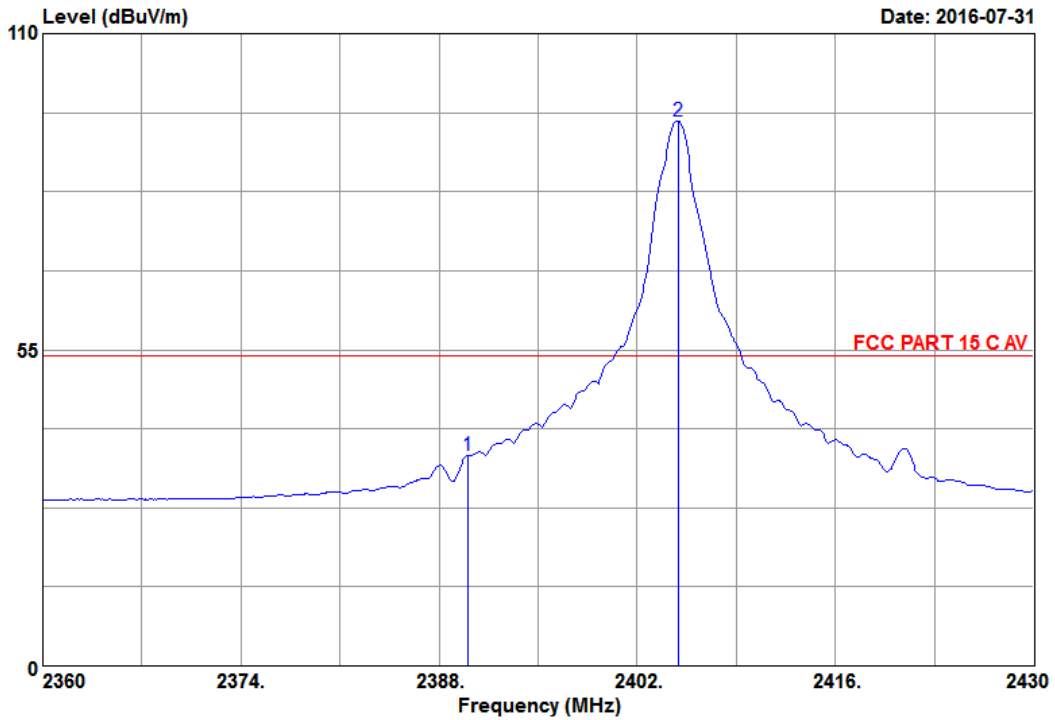

Site NO. : 3m Semi-Anechoic Chamber Data NO. : 22
 Dis. / Ant. : 3m 3115-62961 1509 Ant. pol. : VERTICAL
 Limit : FCC PART 15 C AV
 Env. / Ins. : 20.3*CS&42%/N9030A Engineer : Mickey
 EUT : LED Lamp
 M/N : 9290011998A
 Power Rating: 120Vac/60Hz
 Test Mode : TX CH11 2405MHz
 Memo :

	Freq. (MHz)	Ant. Factor (dB)	Cable Loss (dB)	Reading (dBuV)	Preamp Factor (dB)	Emission Level (dBuV/m)	Limits (dBuV/m)	Margin (dB)	Remark
1	2390.00	28.07	5.09	37.91	34.50	36.57	54.00	17.43	Average
2	2404.91	28.11	5.09	96.13	34.50	94.83	54.00	-40.83	Average

Remarks: 1. Emission Level= Ant.Factor + Cable Loss + Reading - Preamp.Factor.
 2. The emission levels that are 20dB below the official limit are not reported.



Audix Technology(Wujiang)Co.,Ltd.
 No.1289,Jiang Xing East Road,The Eastern Part of Wu Jiang
 Economic Development Zone,JiangSu,China
 Tel: (0512) 63403993 Fax: (0512) 63403993

Data: 23 File: G:\Test Data\2016\Reports\08\G1608005R1.EM6 (26)

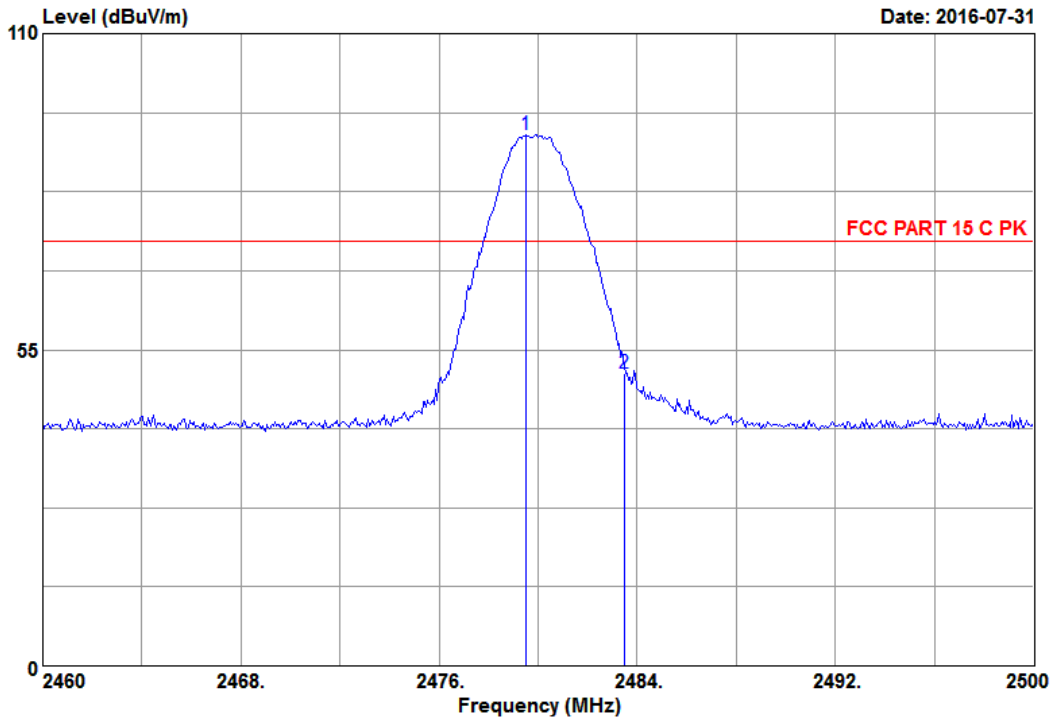

Site NO. : 3m Semi-Anechoic Chamber	Data NO. : 23
Dis. / Ant. : 3m 3115-62961 1509	Ant. pol. : HORIZONTAL
Limit : FCC PART 15 C PK	
Env. / Ins. : 20.3°C&42%/N9030A	Engineer : Mickey
EUT : LED Lamp	
M/N : 9290011998A	
Power Rating: 120Vac/60Hz	
Test Mode : TX CH26 2480MHz	
Memo :	

	Freq. (MHz)	Ant. Factor (dB)	Cable Loss (dB)	Reading (dBuV)	Preamp Factor (dB)	Emission Level (dBuV/m)	Limits (dBuV/m)	Margin (dB)	Remark
1	2479.50	28.26	5.18	93.38	34.49	92.33	74.00	-18.33	Peak
2	2483.50	28.26	5.18	51.92	34.49	50.87	74.00	23.13	Peak

Remarks: 1. Emission Level= Ant.Factor + Cable Loss + Reading - Preamp.Factor.
 2. The emission levels that are 20dB below the official limit are not reported.



Audix Technology(Wujiang)Co.,Ltd.
 No.1289,Jiang Xing East Road,The Eastern Part of Wu Jiang
 Economic Development Zone,JiangSu,China
 Tel: (0512) 63403993 Fax: (0512) 63403993

Data: 24 File: G:\Test Data\2016\Reports\08\G1608005R1.EM6 (26)

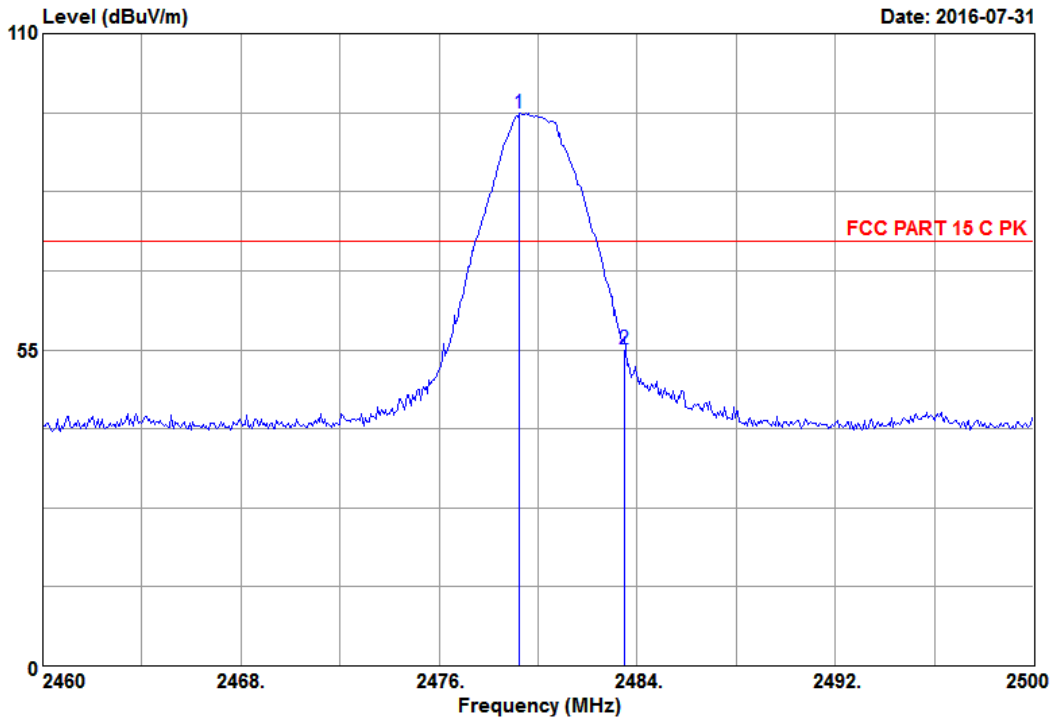

Site NO. : 3m Semi-Anechoic Chamber Data NO. : 24
 Dis. / Ant. : 3m 3115-62961 1509 Ant. pol. : VERTICAL
 Limit : FCC PART 15 C PK
 Env. / Ins. : 20.3°C&42%/N9030A Engineer : Mickey
 EUT : LED Lamp
 M/N : 9290011998A
 Power Rating: 120Vac/60Hz
 Test Mode : TX CH26 2480MHz
 Memo :

	Freq. (MHz)	Ant. Factor (dB)	Cable Loss (dB)	Reading (dBuV)	Preamp Factor (dB)	Emission Level (dBuV/m)	Limits (dBuV/m)	Margin (dB)	Remark
1	2479.26	28.26	5.18	97.16	34.49	96.11	74.00	-22.11	Peak
2	2483.50	28.26	5.18	56.11	34.49	55.06	74.00	18.94	Peak

Remarks: 1. Emission Level= Ant.Factor + Cable Loss + Reading - Preamp.Factor.
 2. The emission levels that are 20dB below the official limit are not reported.



Audix Technology(Wujiang)Co.,Ltd.
 No.1289,Jiang Xing East Road,The Eastern Part of Wu Jiang
 Economic Development Zone,JiangSu,China
 Tel: (0512) 63403993 Fax: (0512) 63403993

Data: 25 File: G:\Test Data\2016\Reports\08\G1608005R1.EM6 (26)

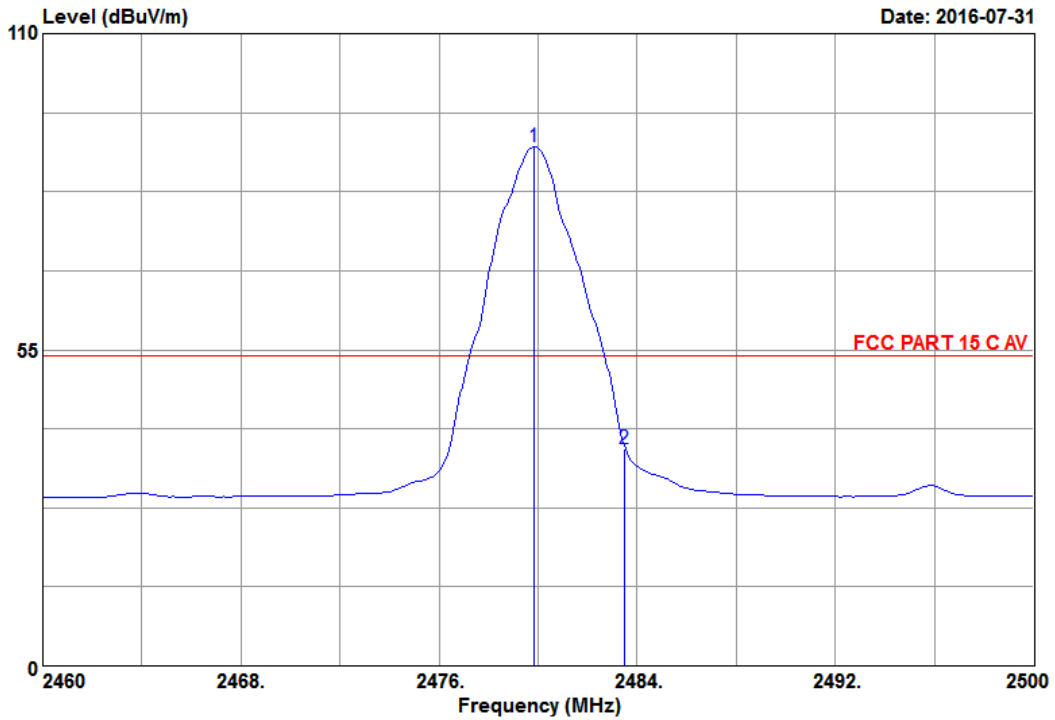

Site NO. : 3m Semi-Anechoic Chamber	Data NO. : 25
Dis. / Ant. : 3m 3115-62961 1509	Ant. pol. : HORIZONTAL
Limit : FCC PART 15 C AV	
Env. / Ins. : 20.3*CS&42%/N9030A	Engineer : Mickey
EUT : LED Lamp	
M/N : 9290011998A	
Power Rating: 120Vac/60Hz	
Test Mode : TX CH26 2480MHz	
Memo :	

	Freq. (MHz)	Ant. Factor (dB)	Cable Loss (dB)	Reading (dBuV)	Preamp Factor (dB)	Emission Level (dBuV/m)	Limits (dBuV/m)	Margin (dB)	Remark
1	2479.86	28.26	5.18	91.30	34.49	90.25	54.00	-36.25	Average
2	2483.50	28.26	5.18	38.78	34.49	37.73	54.00	16.27	Average

Remarks: 1. Emission Level= Ant.Factor + Cable Loss + Reading - Preamp.Factor.
 2. The emission levels that are 20dB below the official limit are not reported.



Audix Technology(Wujiang)Co.,Ltd.
 No.1289,Jiang Xing East Road,The Eastern Part of Wu Jiang
 Economic Development Zone,JiangSu,China
 Tel: (0512) 63403993 Fax: (0512) 63403993

Data: 26 File: G:\Test Data\2016\Reports\08\G1608005R1.EM6 (26)

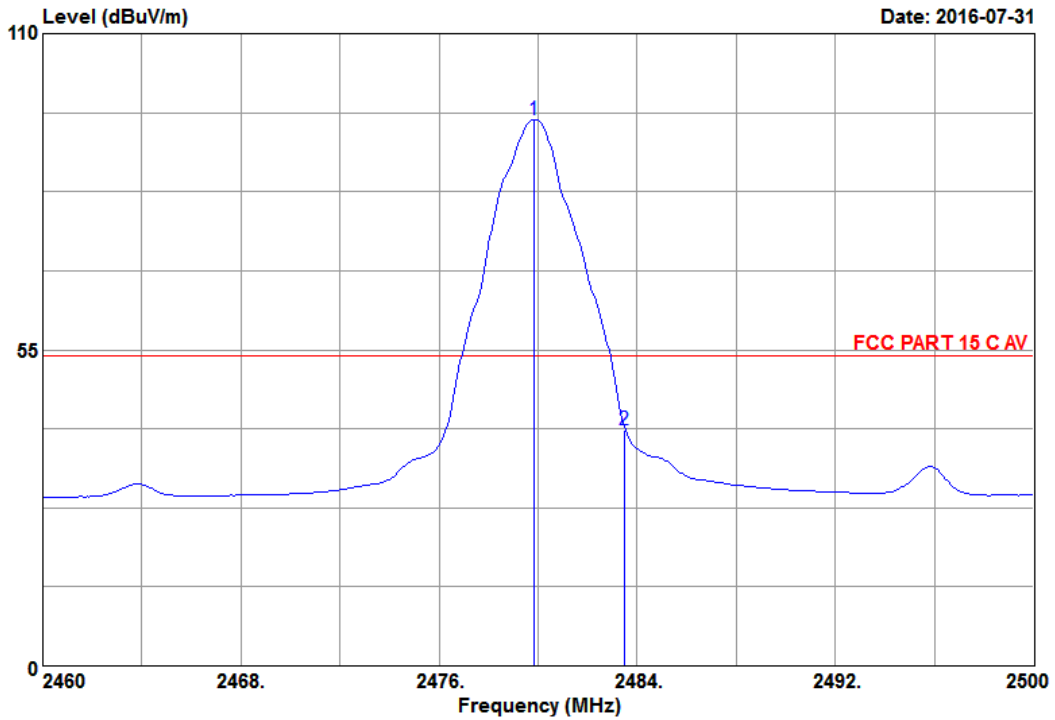

Site NO. : 3m Semi-Anechoic Chamber
 Dis. / Ant. : 3m 3115-62961 1509
 Limit : FCC PART 15 C AV
 Env. / Ins. : 20.3°C&42%/N9030A
 EUT : LED Lamp
 M/N : 9290011998A
 Power Rating: 120Vac/60Hz
 Test Mode : TX CH26 2480MHz
 Memo :
 Data NO. : 26
 Ant. pol. : VERTICAL
 Engineer : Mickey

	Freq. (MHz)	Ant. Factor (dB)	Cable Loss (dB)	Reading (dBuV)	Preamp Factor (dB)	Emission Level (dBuV/m)	Limits (dBuV/m)	Margin (dB)	Remark
1	2479.86	28.26	5.18	96.16	34.49	95.11	54.00	-41.11	Average
2	2483.50	28.26	5.18	42.14	34.49	41.09	54.00	12.91	Average

Remarks: 1. Emission Level= Ant.Factor + Cable Loss + Reading - Preamp.Factor.
 2. The emission levels that are 20dB below the official limit are not reported.

6. 6 dB BANDWIDTH MEASUREMENT

6.1. Test Equipment

Item	Type	Manufacturer	Model No.	Serial No.	Last Cal.	Next Cal.
1.	PXA Signal Analyzer	Agilent	N9030A	MY53120367	2016-05-15	2017-05-14

6.2. Block Diagram of Test Setup

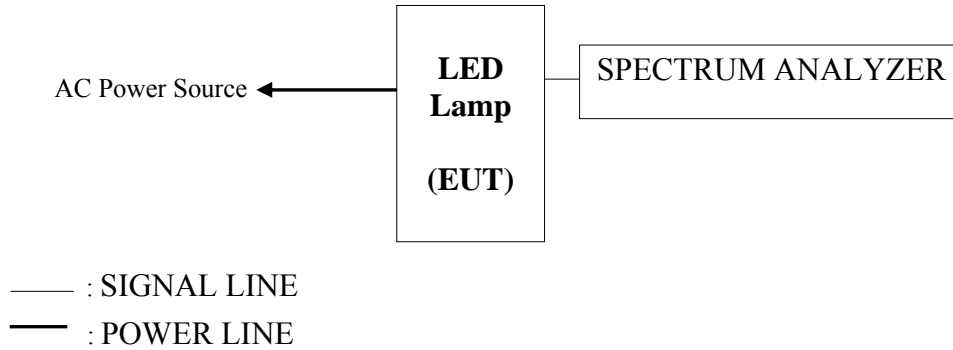

6.3. Specification Limits (§15.247(a)(2))

Systems using digital modulation techniques may operate in the 902 - 928 MHz, 2400 - 2483.5 MHz, and 5725 - 5850 MHz bands. The minimum 6 dB bandwidth shall be at least 500kHz.

6.4. Test Procedure

The steps for the first option are as bellow:

- a) Set RBW = 100 kHz.
- b) Set the VBW [3 × RBW].
- c) Detector = peak.
- d) Trace mode = max hold.
- e) Sweep = auto couple.
- f) Allow the trace to stabilize.
- g) Measure the maximum width of the emission that is constrained by the frequencies associated with the two outermost amplitude points (upper and lower frequencies) that are attenuated by 6 dB relative to the maximum level measured in the fundamental emission.

6.5. Test Results

PASSED. All the test results are attached in next pages.

Channel	Center Frequency(MHz)	6 dB Bandwidth(kHz)
11	2405	606.3
20	2450	601.5
26	2480	611.1

CH 11

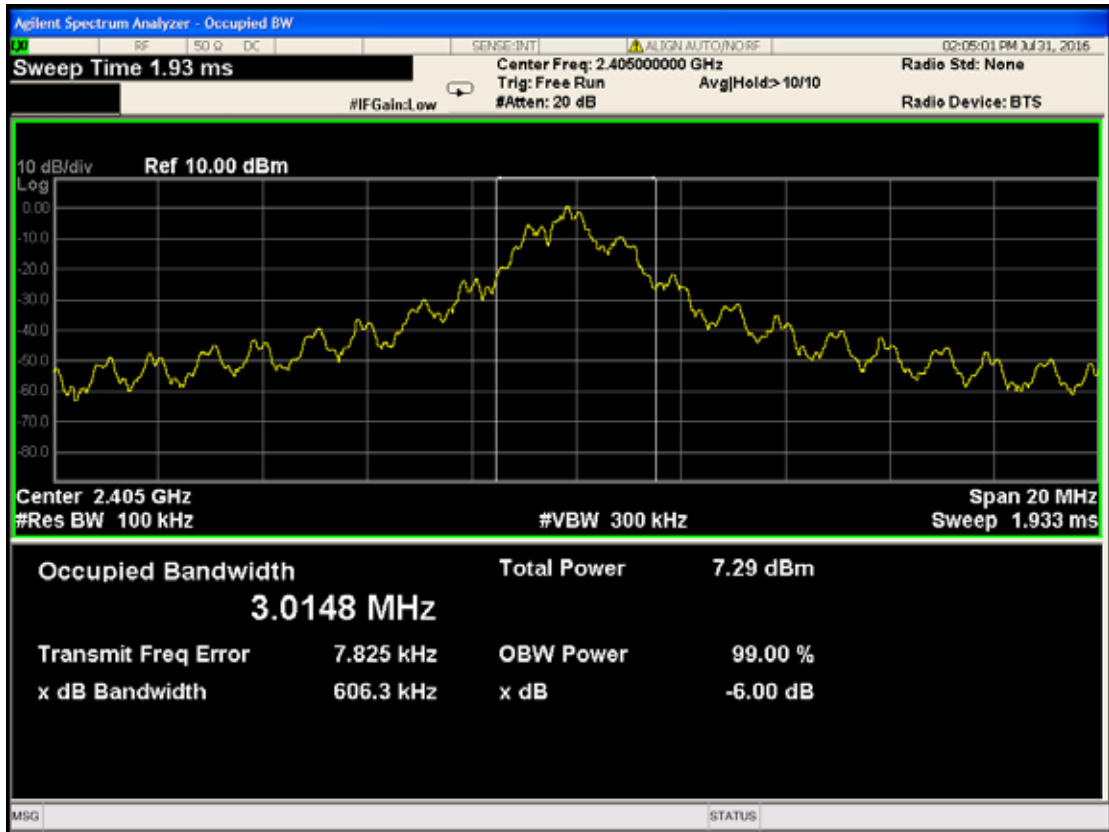

CH 20

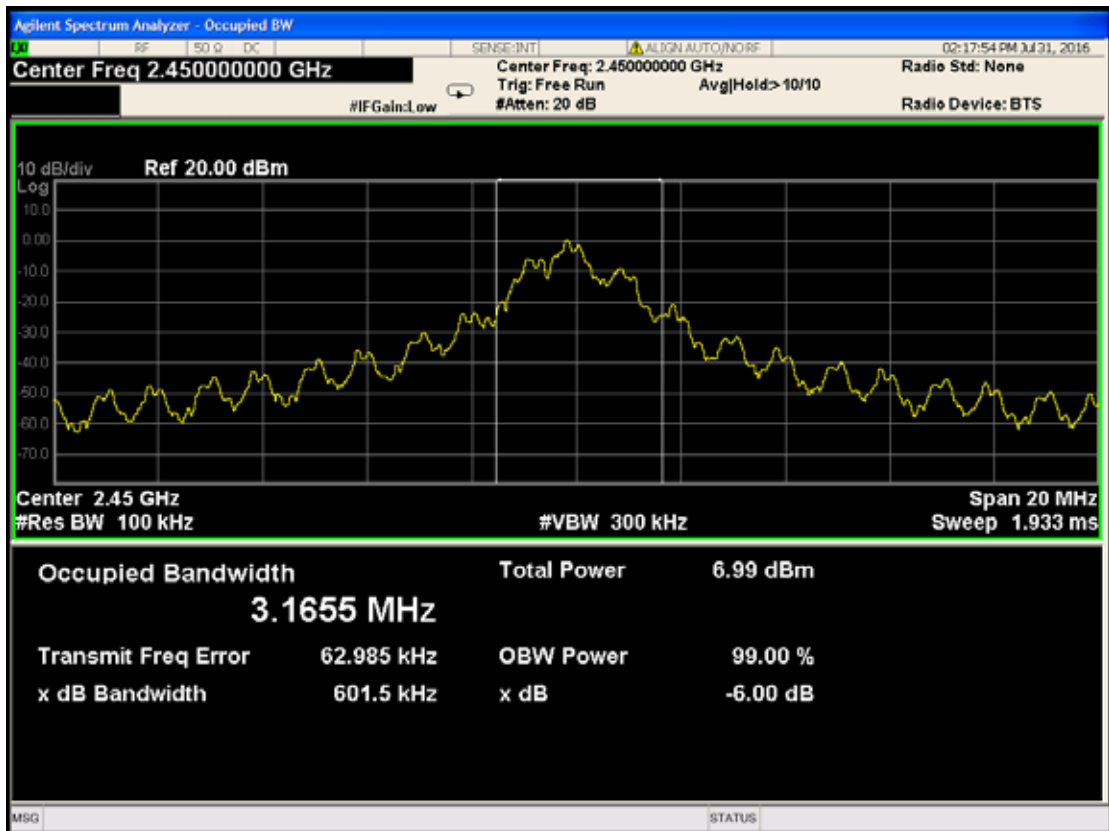

CH 26

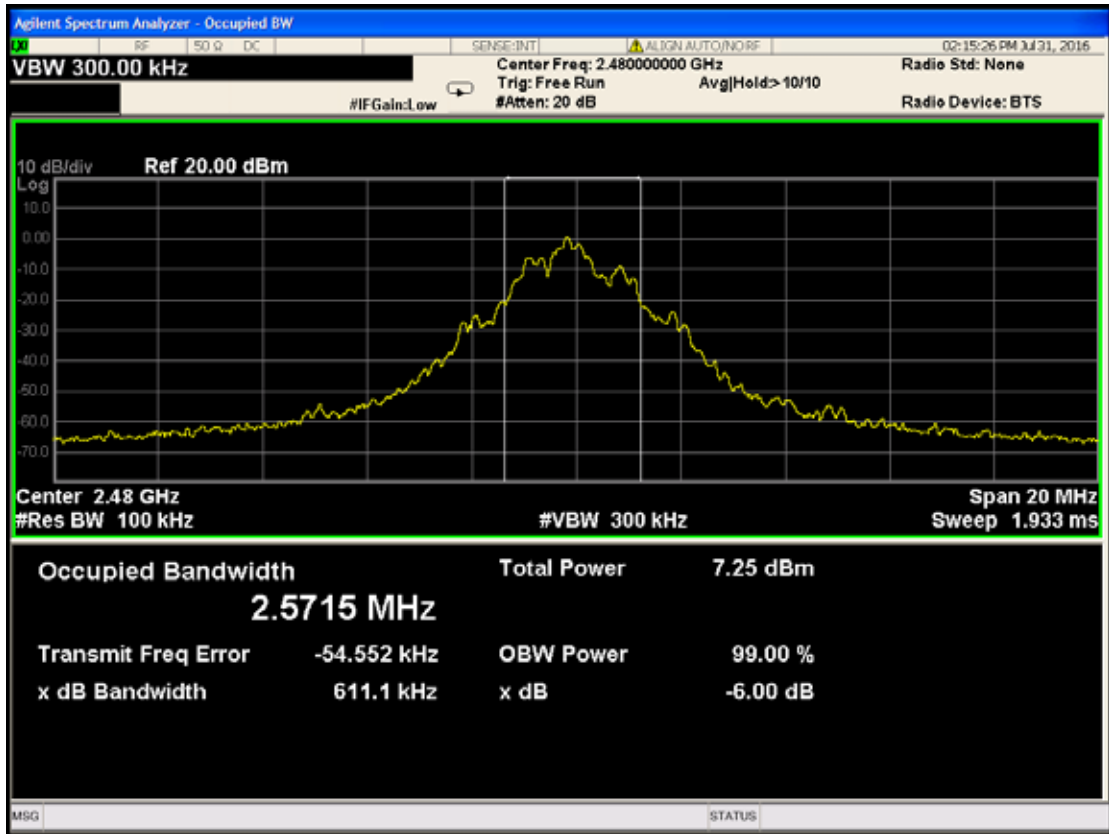

7. OUTPUT POWER MEASUREMENT

7.1. Test Equipment

Item	Type	Manufacturer	Model No.	Serial No.	Last Cal.	Next Cal.
1.	PXA Signal Analyzer	Agilent	N9030A	MY53120367	2016-05-15	2017-05-14

7.2. Block Diagram of Test Setup

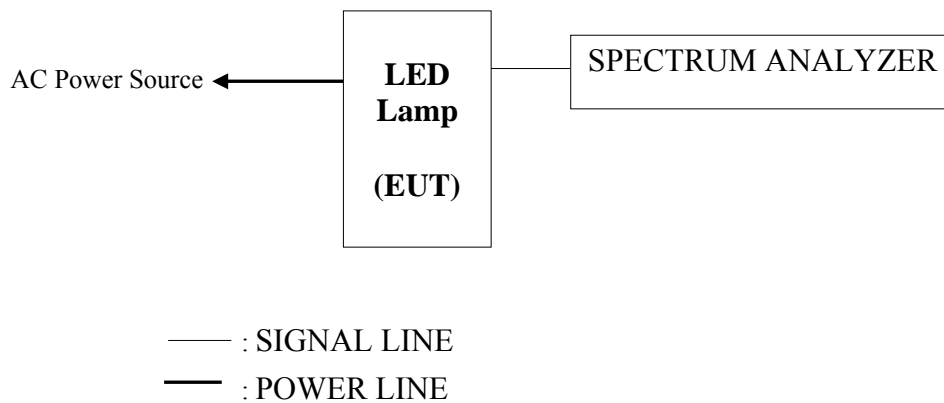

7.3. Specification Limits (§15.247(b)(3))

For systems using digital modulation in the 902-928 MHz, 2400-2483.5 MHz, and 5725-5850 MHz bands: 1 Watt. As an alternative to a peak power measurement, compliance with the one Watt limit can be based on a measurement of the maximum conducted output power. Maximum Conducted Output Power is defined as the total transmit power delivered to all antennas and antenna elements averaged across all symbols in the signaling alphabet when the transmitter is operating at its maximum power control level. Power must be summed across all antennas and antenna elements. The average must not include any time intervals during which the transmitter is off or is transmitting at a reduced power level. If multiple modes of operation are possible (e.g., alternative modulation methods), the maximum conducted output power is the highest total transmit power occurring in any mode.

7.4. Test Procedure

- a) Set span to at least 1.5 times the OBW.
- b) Set RBW = 1-5% of the OBW, not to exceed 1 MHz.
- c) Set VBW $\geq 3 \times$ RBW.
- d) Number of points in sweep $\geq 2 \times$ span / RBW. (This gives bin-to-bin spacing \leq RBW/2, so that narrowband signals are not lost between frequency bins.)
- e) Sweep time = auto.
- f) Detector = RMS (i.e., power averaging), if available. Otherwise, use sample detector mode.
- g) If transmit duty cycle < 98 %, use a sweep trigger with the level set to enable triggering only on full power pulses. The transmitter shall operate at maximum power control level for the entire duration of every sweep. If the EUT transmits continuously (i.e., with no off intervals) or at duty cycle ≥ 98 %, and if each transmission is entirely at the maximum power control level, then the trigger shall be set to “free run”.
- h) Trace average at least 100 traces in power averaging (i.e., RMS) mode.
- i) Compute power by integrating the spectrum across the OBW of the signal using the instrument’s band power measurement function, with band limits set equal to the OBW band edges. If the instrument does not have a band power function, sum the spectrum levels (in power units) at intervals equal to the RBW extending across the entire OBW of the spectrum.

7.5. Test Results

PASSED. All the test results are attached in next pages.

Channel	Frequency	Power(dBm)	Limit(dBm)
11	2405	2.38	30
20	2450	2.32	30
26	2480	2.46	30

8. BAND EDGES MEASUREMENT

8.1. Test Equipment

Item	Type	Manufacturer	Model No.	Serial No.	Last Cal.	Next Cal.
1.	PXA Signal Analyzer	Agilent	N9030A	MY53120367	2016-05-15	2017-05-14

8.2. Block Diagram of Test Setup

The same as section 5.2.

8.3. Specification Limits (§15.247(d))

In any 100 kHz bandwidth outside the frequency band in which the spread spectrum or digitally modulated intentional radiator is operating, the radio frequency power that is produced by the intentional radiator shall be at least 20 dB below that in the 100 kHz bandwidth within the band that contains the highest level of the desired power, based on either an RF conducted or a radiated measurement, provided the transmitter demonstrates compliance with the peak conducted power limits. If the transmitter complies with the conducted power limits based on the use of RMS averaging over a time interval, as permitted under paragraph (b)(3) of this section, the attenuation required under this paragraph shall be 30 dB instead of 20 dB. Attenuation below the general limits specified in Section 15.209(a) is not required. In addition, radiated emissions which fall in the restricted bands, as defined in Section 15.205(a), must also comply with the radiated emission limits specified in Section 15.209(a) (see Section 15.205(c)).

8.4. Test Procedure

The transmitter output was connected to the test receiver / spectrum analyzer. Set RBW of spectrum analyzer to 100kHz and VBW to 300kHz with suitable frequency span including 100kHz bandwidth from band edge.

8.5. Test Results

PASSED. The testing data was attached in the next pages.

CH11

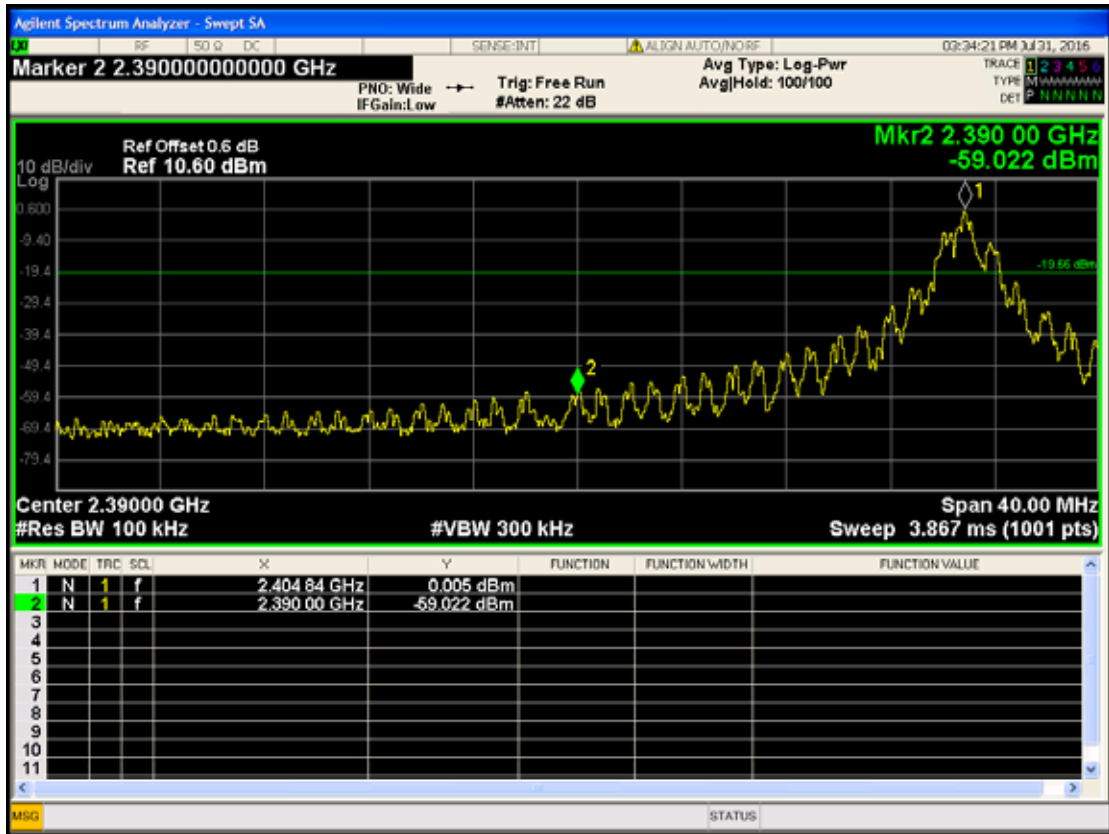

CH26

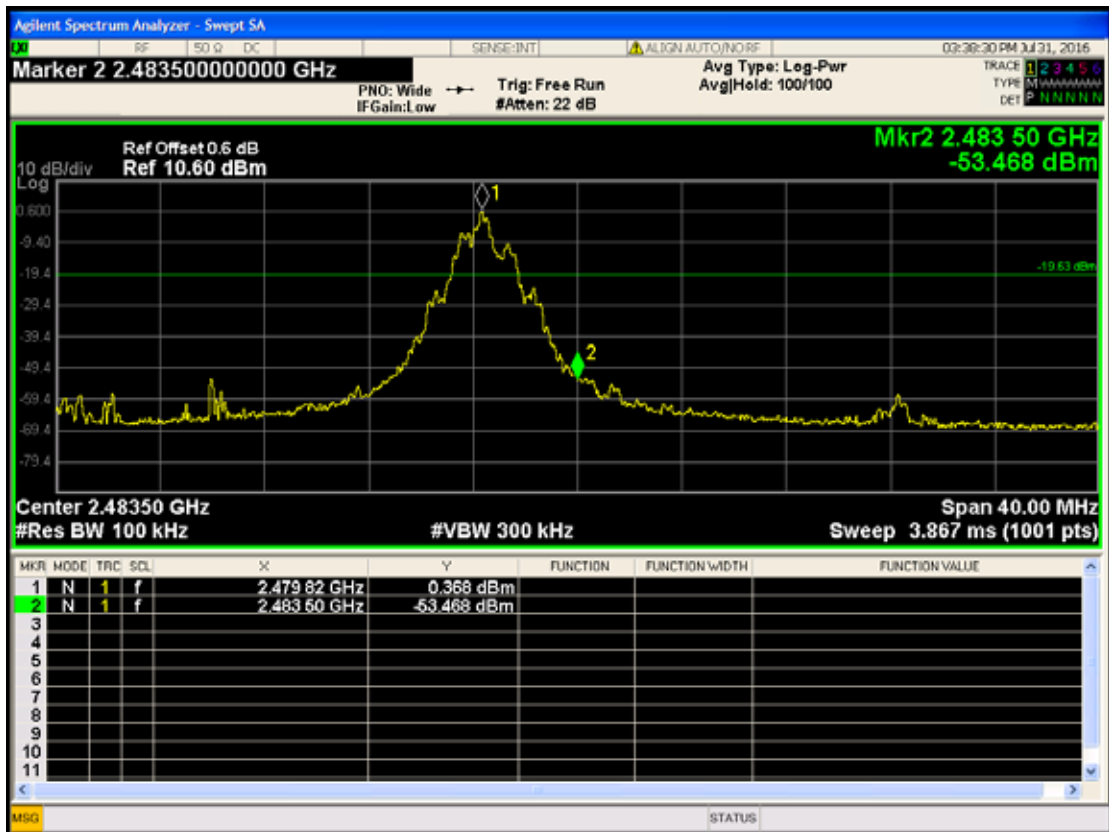

9. POWER SPECTRAL DENSITY MEASUREMENT

9.1. Test Equipment

Item	Type	Manufacturer	Model No.	Serial No.	Last Cal.	Next Cal.
1.	PXA Signal Analyzer	Agilent	N9030A	MY53120367	2016-05-15	2017-05-14

9.2. Block Diagram of Test Setup

The same as section 5.2.

9.3. Specification Limits (§15.247(e))

For digitally modulated systems, the power spectral density conducted from the intentional radiator to the antenna shall not be greater than 8 dBm in any 3 kHz band during any time interval of continuous transmission.

9.4. Test Results

PASSED. All the test results are attached in next page.

Channel	Frequency(GHz)	Value(dBm/3kHz)
11	2.405	-0.382
20	2.450	-0.578
26	2.480	-0.359

CH 26

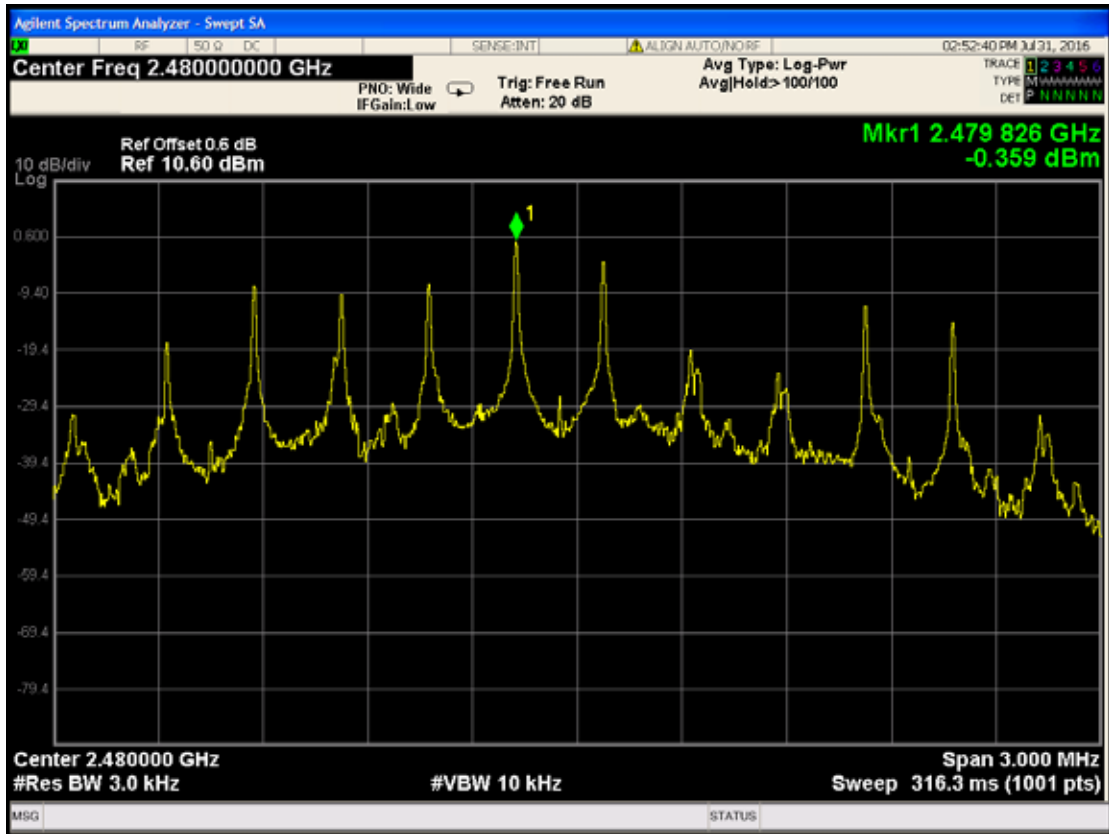

10.EMISSION LIMITATIONS MEASUREMENT

10.1. Test Equipment

Item	Type	Manufacturer	Model No.	Serial No.	Last Cal.	Next Cal.
1.	PXA Signal Analyzer	Agilent	N9030A	MY53120367	2015-05-15	2017-05-14

10.2. Block Diagram of Test Setup

The same as section 5.2.

10.3. Specification Limits (§15.247(d))

In any 100 kHz bandwidth outside the frequency band in which the spread spectrum or digitally modulated intentional radiator is operating, the radio frequency power that is produced by the intentional radiator shall be at least 20 dB below that in the 100 kHz bandwidth within the band that contains the highest level of the desired power, based on either an RF conducted or a radiated measurement, provided the transmitter demonstrates compliance with the peak conducted power limits. If the transmitter complies with the conducted power limits based on the use of RMS averaging over a time interval, as permitted under paragraph (b)(3) of this section, the attenuation required under this paragraph shall be 30 dB instead of 20 dB. Attenuation below the general limits specified in Section 15.209(a) is not required. In addition, radiated emissions which fall in the restricted bands, as defined in Section 15.205(a), must also comply with the radiated emission limits specified in Section 15.209(a) (see Section 15.205(c)).

10.4. Test Procedure

The transmitter output was connected to the spectrum analyzer. Set RBW = 100kHz, VBW \geq 300 kHz, scan up through 10th harmonic. All harmonics/spurs must be at least 30 dB down from the highest emission level within the authorized band as measured with a 100 kHz RBW. The measurement guideline was according to KDB558074 v03r05.

10.5. Test Results

PASSED. All the test results are attached in next pages.

Channel	Frequency(MHz)	Amplitude(dBm)
11	959.79	-62.772
	598.91	-68.451
	2404.80	0.121
	2259.80	-67.871
	3737.05	-62.382
	4809.90	-62.070
	5556.45	-63.914
	5132.95	-62.411
	7741.80	-63.244
	8903.35	-62.910
	9640.55	-63.273
	10723.85	-63.283
	12265.55	-63.268
	11420.90	-63.122
	13657.50	-62.830
	13935.00	-62.708
	15936.65	-62.415
	15735.80	-62.682
	18141.55	-62.415
	18477.00	-61.823
	19933.65	-61.053
	19217.50	-59.663
	22734.30	-59.949
	21478.45	-60.535
23711.15	-59.578	
24355.05	-58.926	
20	959.79	-65.412
	759.25	-69.858
	2135.00	-67.989
	2449.80	-0.186
	4216.00	-63.907
	3846.50	-62.476

	6238.35	-64.151
	5067.05	-62.755
	8085.40	-62.792
	7771.90	-63.497
	10726.65	-62.921
	9031.55	-62.890
	11034.80	-63.011
	12129.20	-63.622
	14754.80	-61.826
	14238.60	-62.413
	15036.00	-62.092
	15690.50	-62.330
	18623.45	-60.836
	18437.60	-60.815
	19199.80	-60.271
	19895.45	-60.885
	22756.60	-60.553
	22210.00	-58.994
	23574.60	-59.723
	24837.00	-59.809
	959.79	-64.325
	686.16	-71.194
	2479.80	0.407
	1659.30	-69.833
	3695.65	-62.914
	3833.65	-62.675
	6291.50	-62.253
	5865.15	-65.069
26	7675.35	-63.498
	8552.60	-62.513
	10714.55	-62.522
	10179.15	-62.750
	11648.95	-63.523
	11049.20	-62.723
	14705.40	-62.678
	14179.75	-62.988
	16104.70	-62.373

	15131.15	-62.340
	18680.25	-61.352
	17961.60	-62.100
	19275.25	-60.740
	20744.55	-61.334
	21415.10	-60.289
	22508.75	-60.453
	23909.00	-59.223
	24924.90	-59.607

CH 11

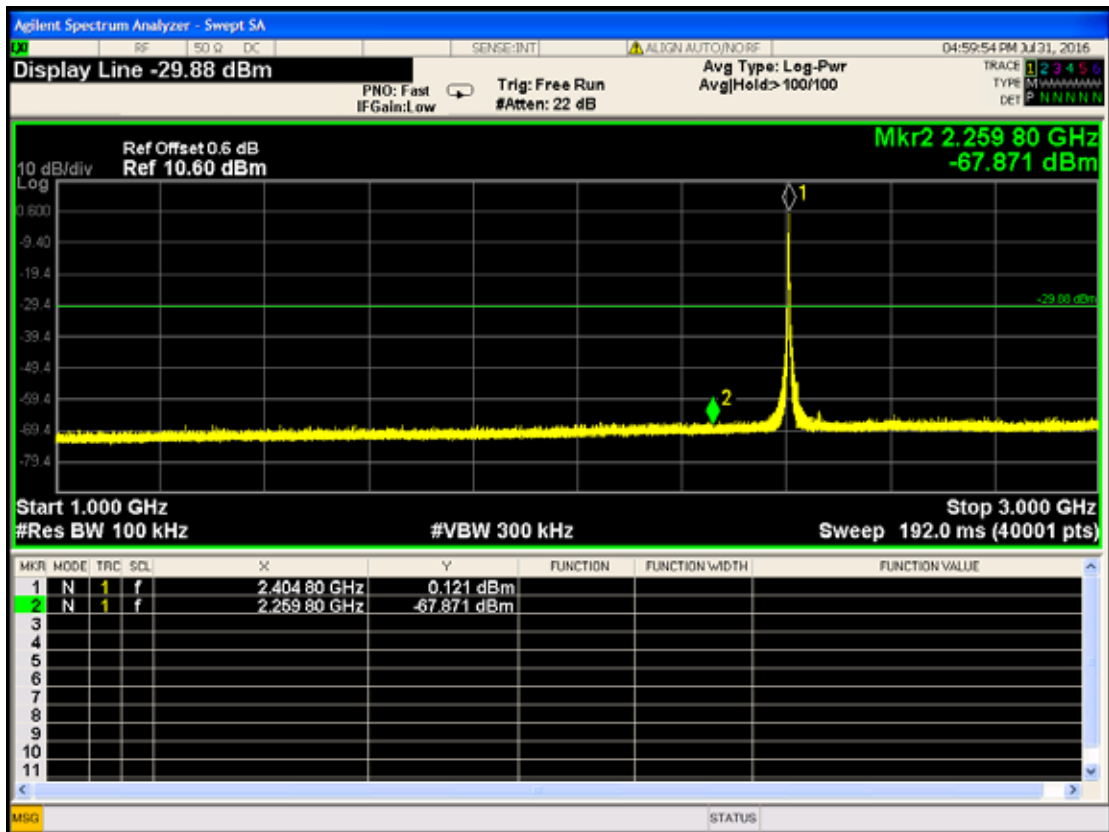
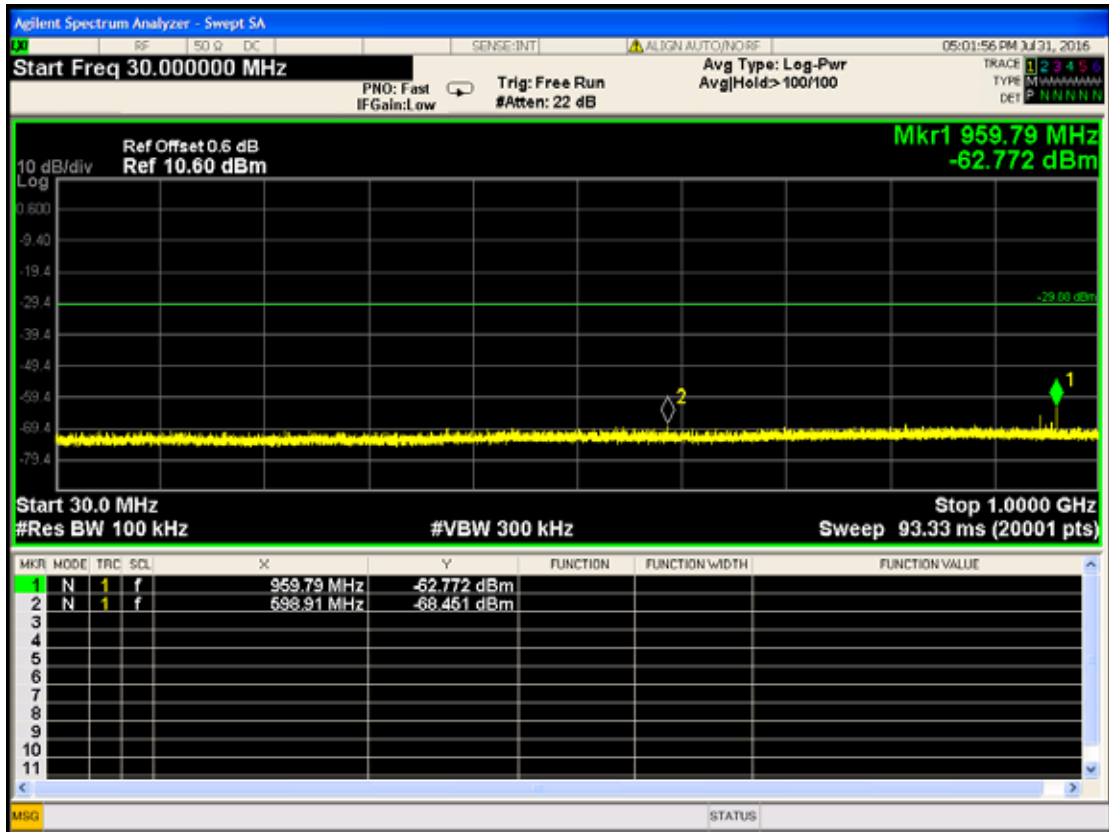

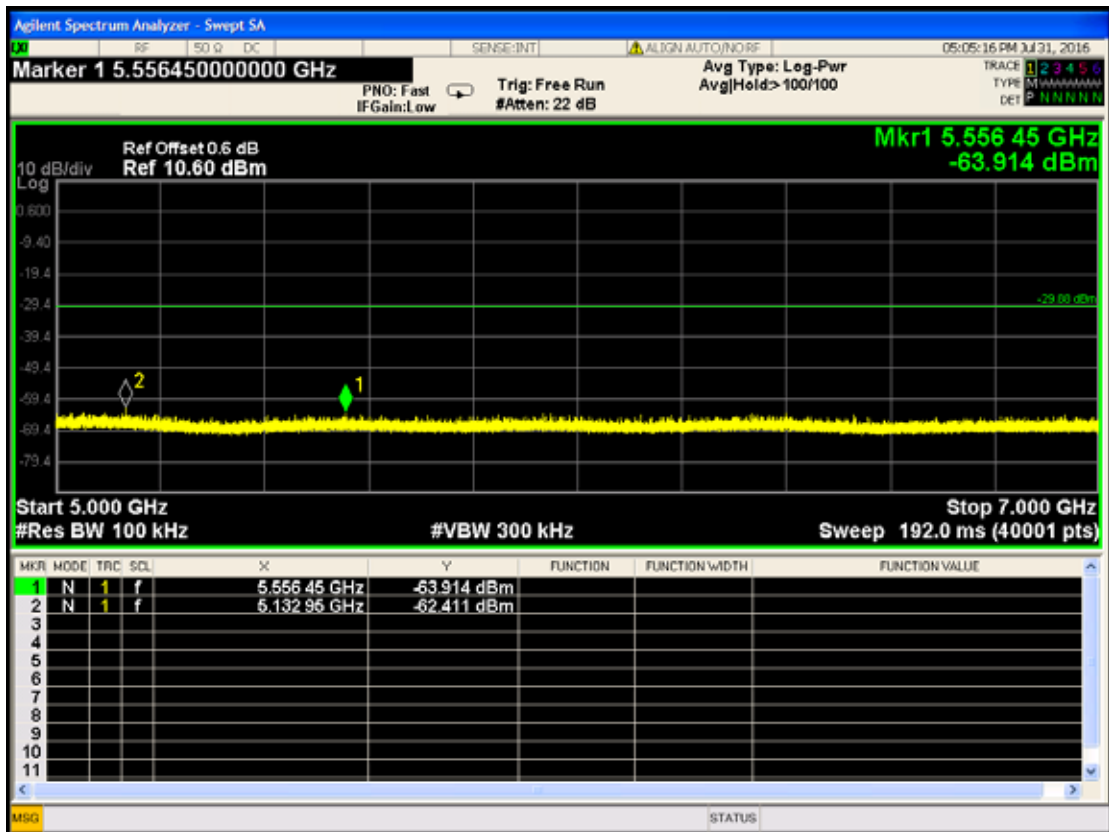
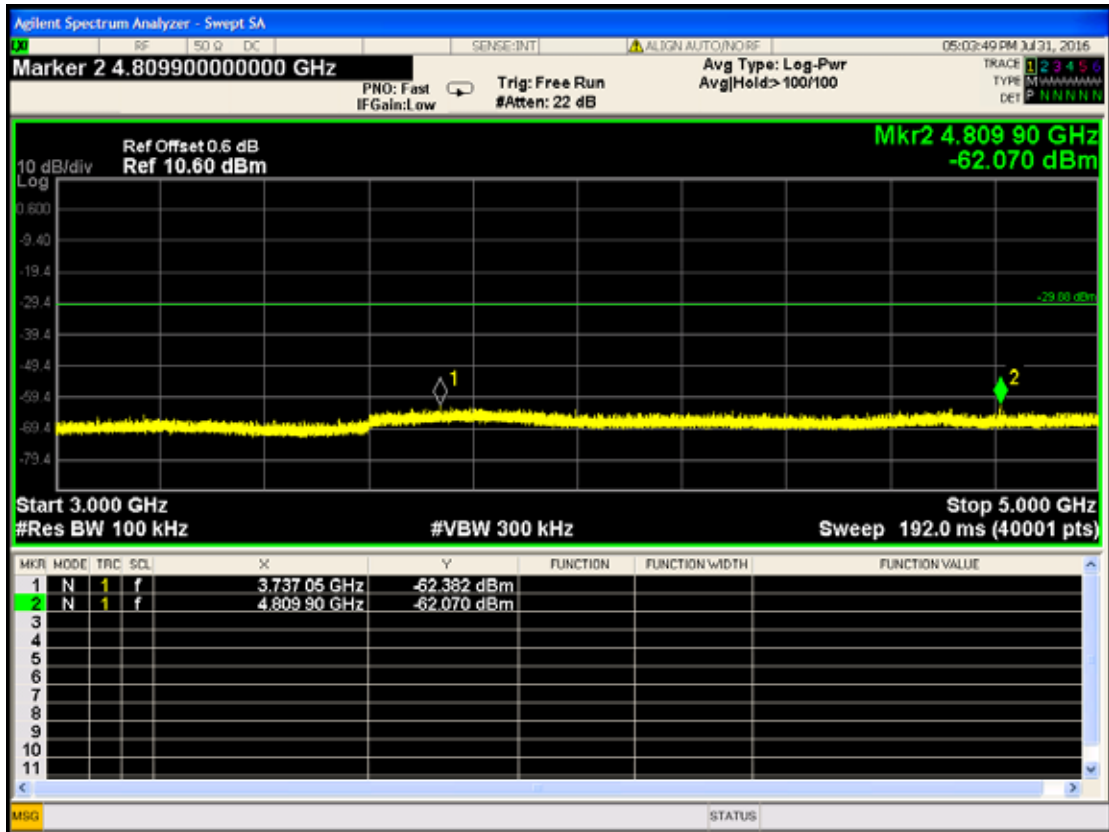

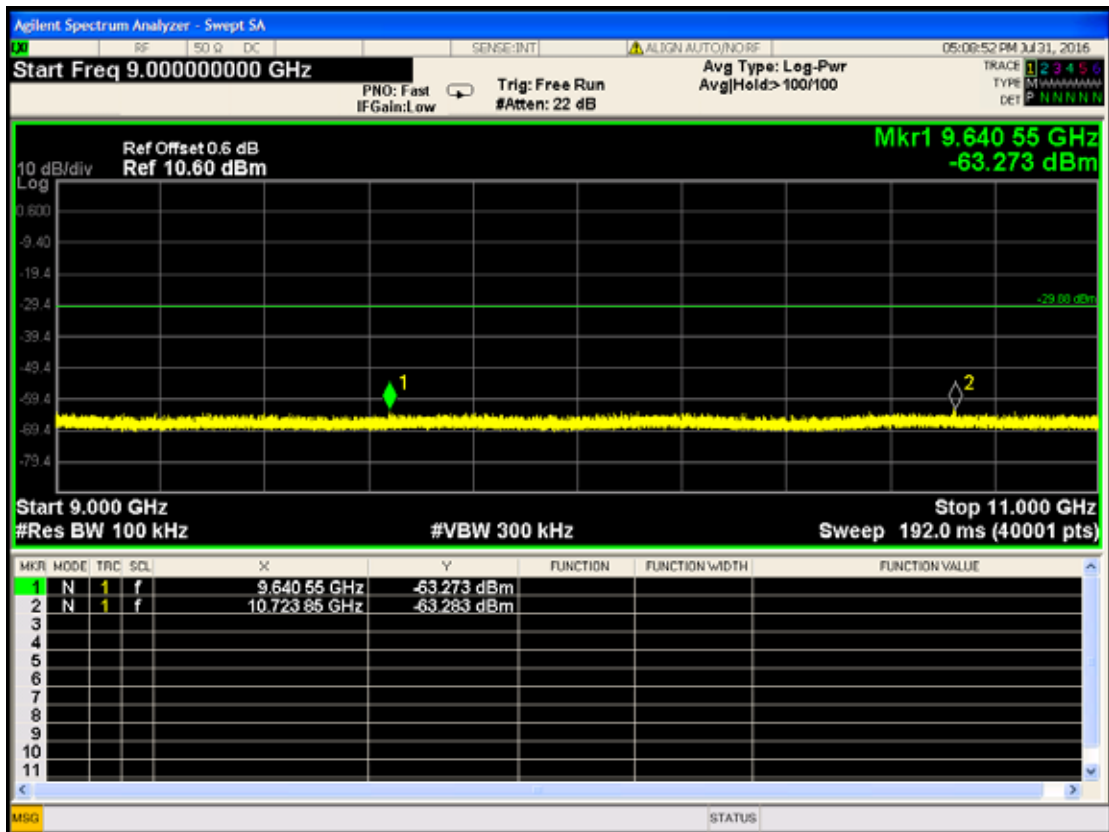
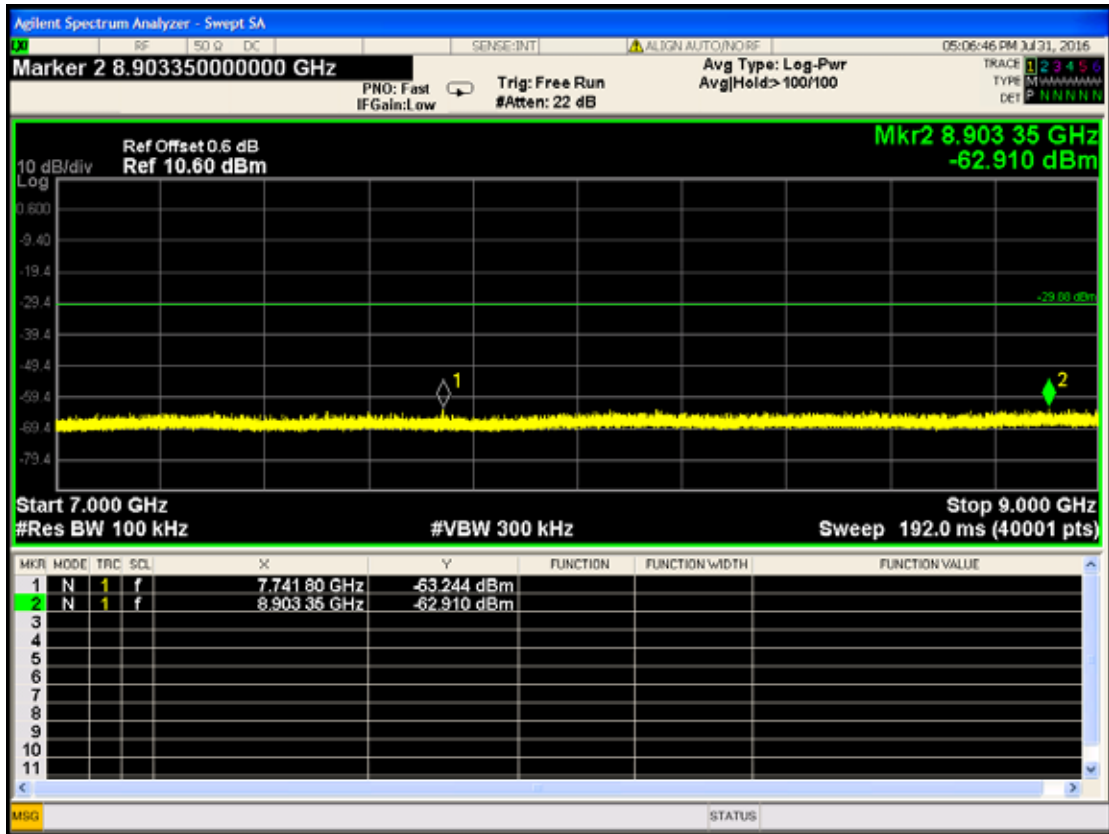

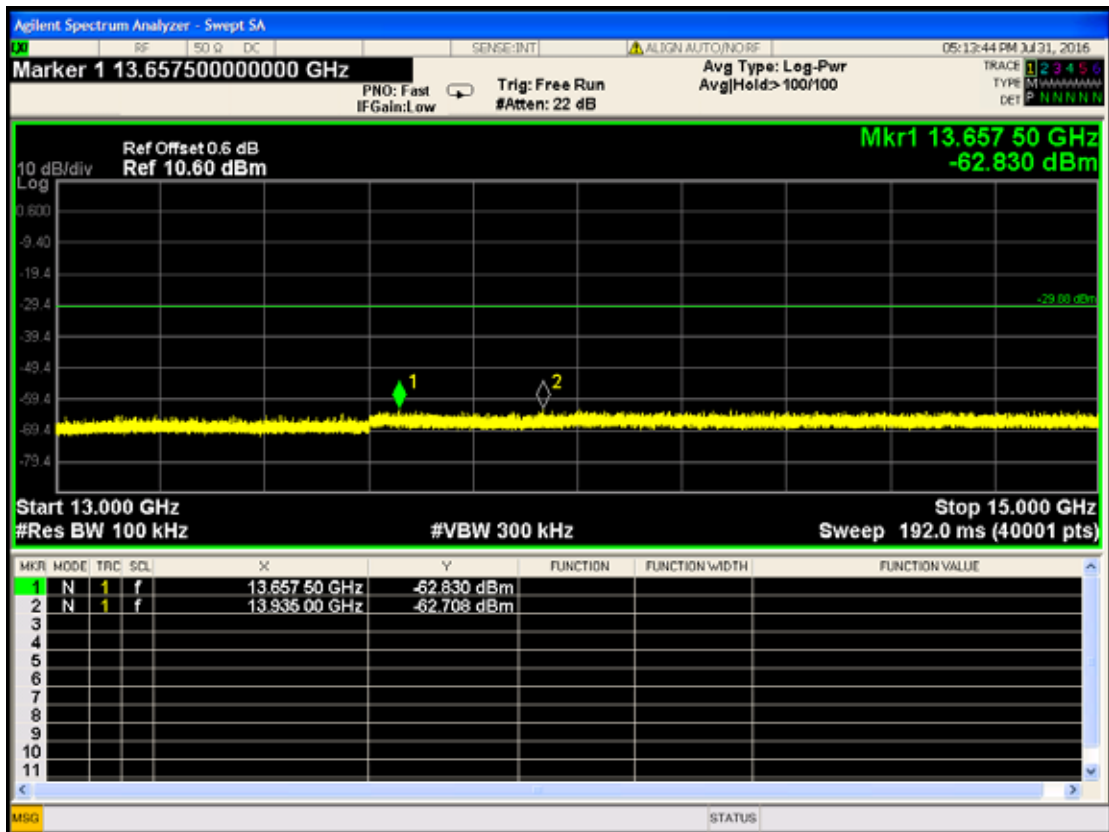
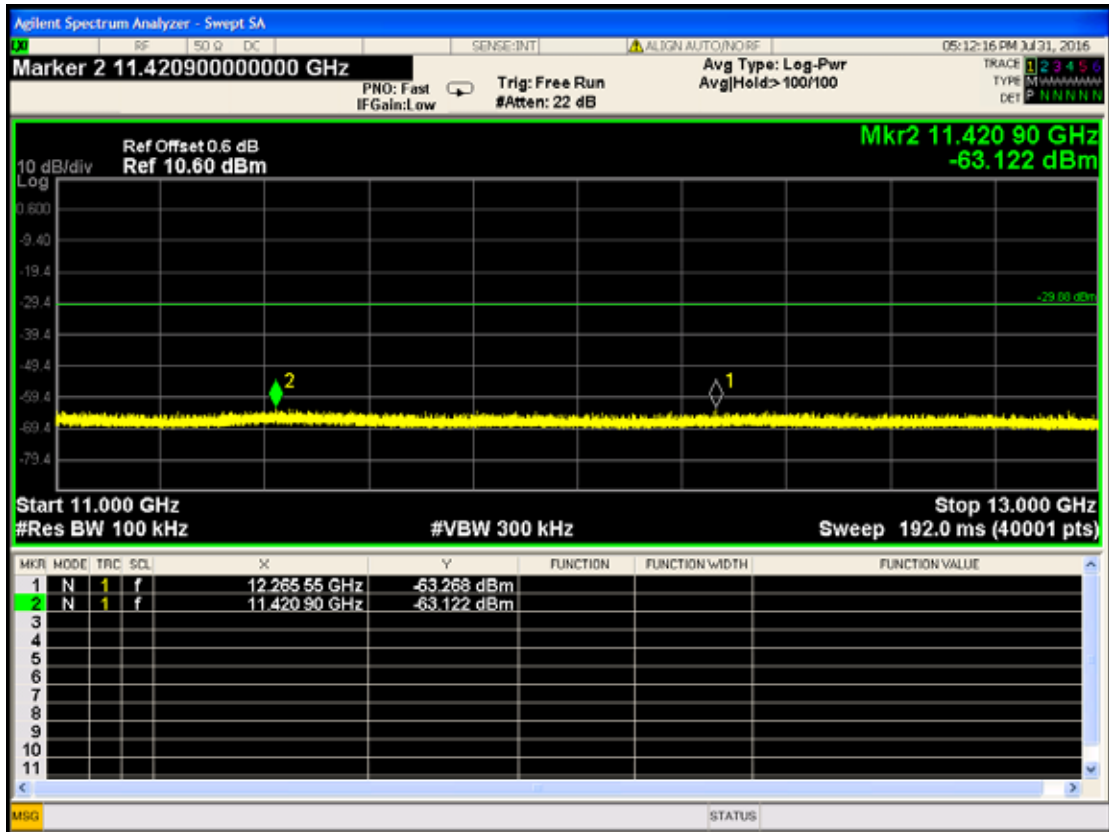

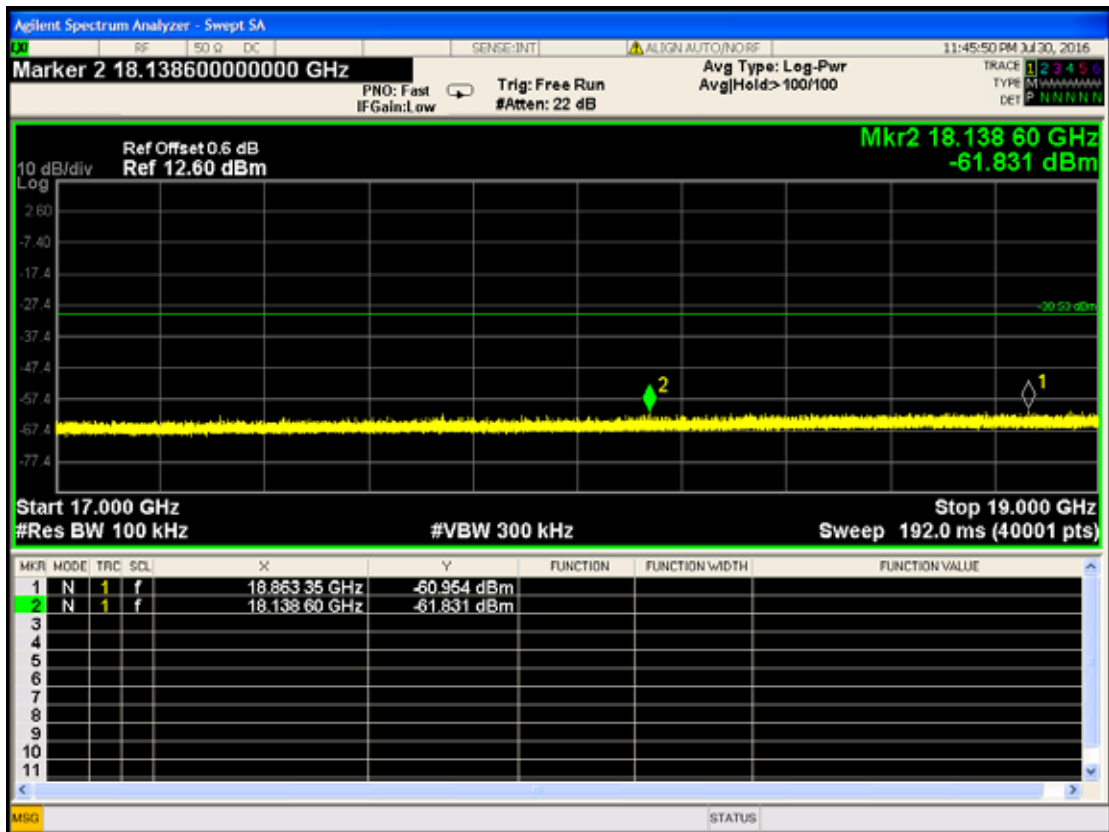
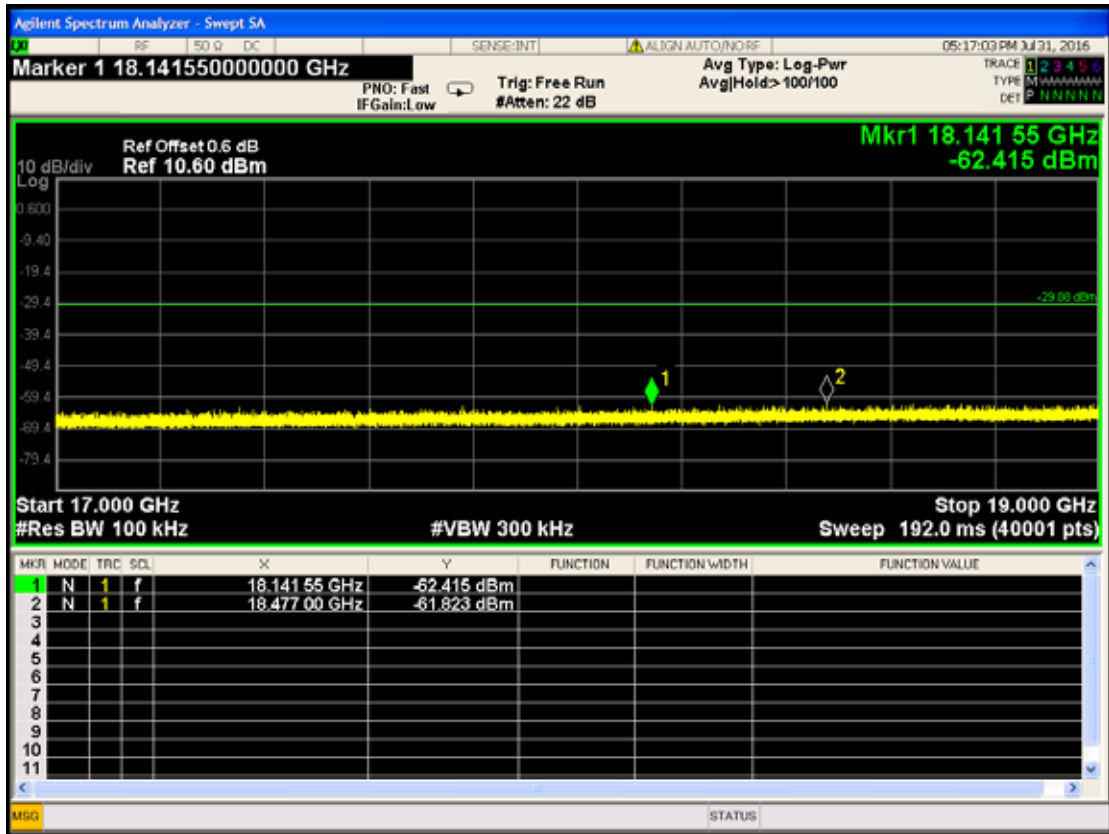

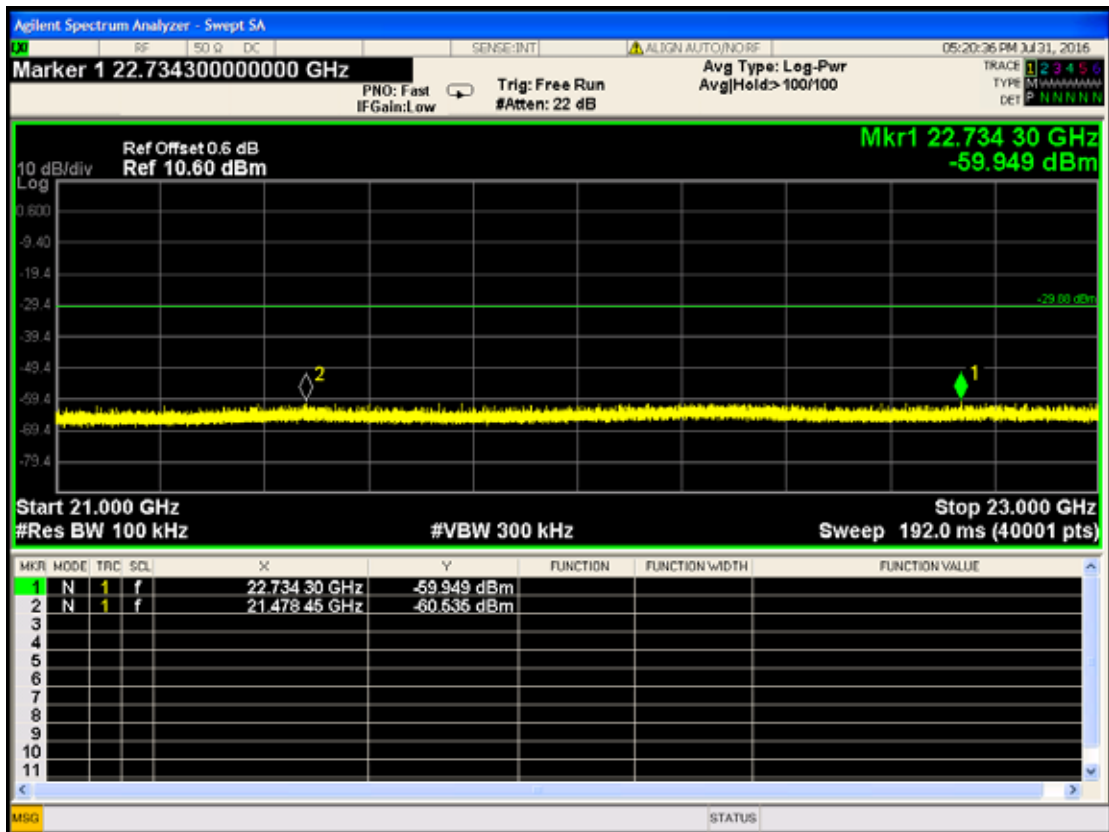
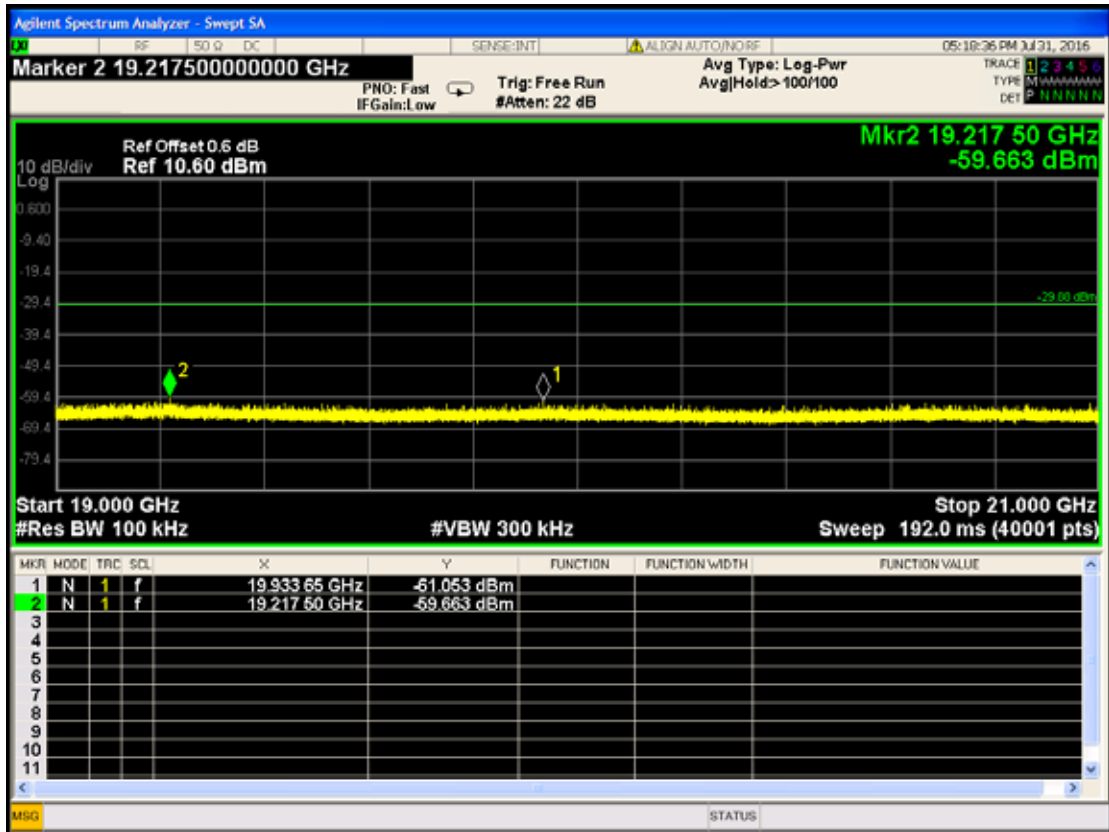

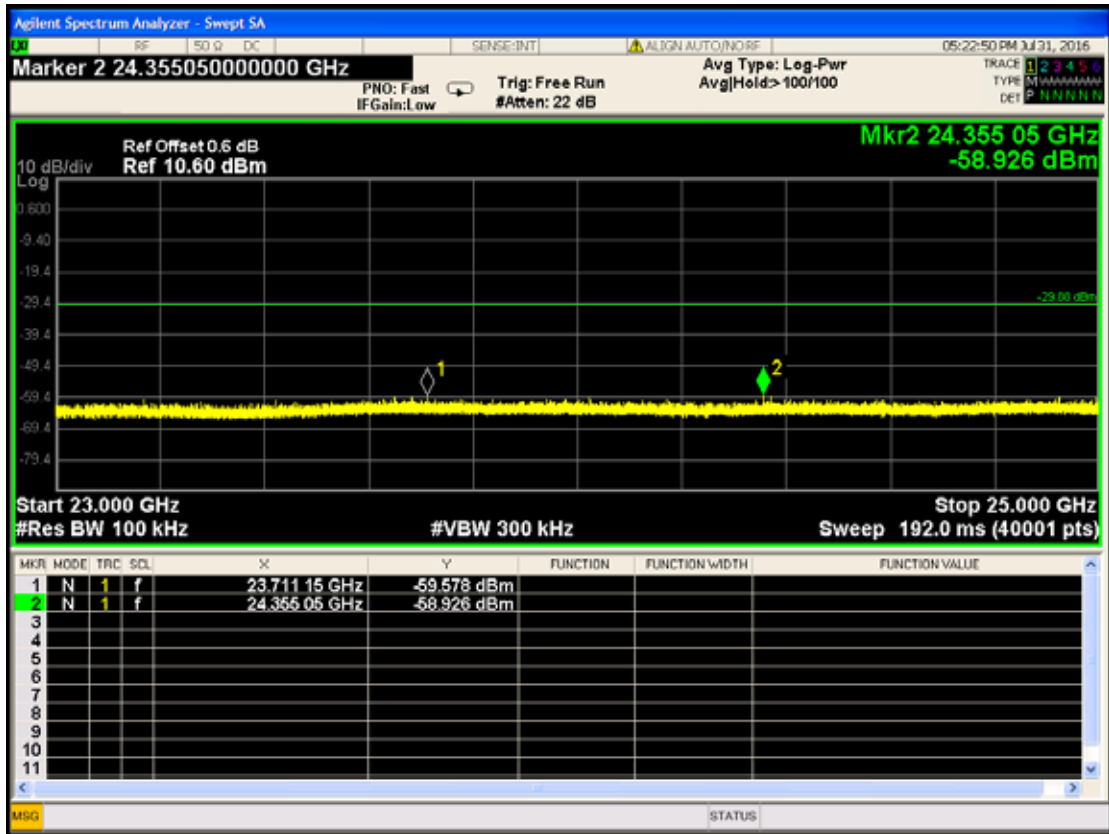

CH 20

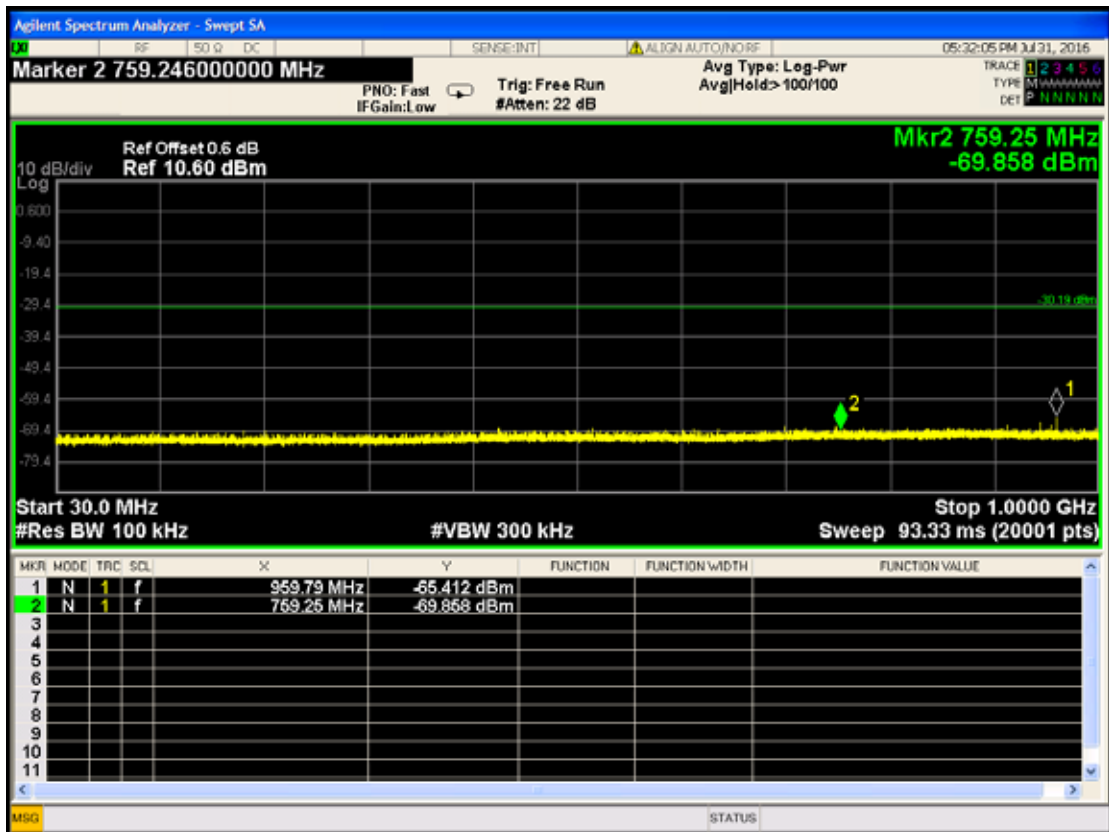

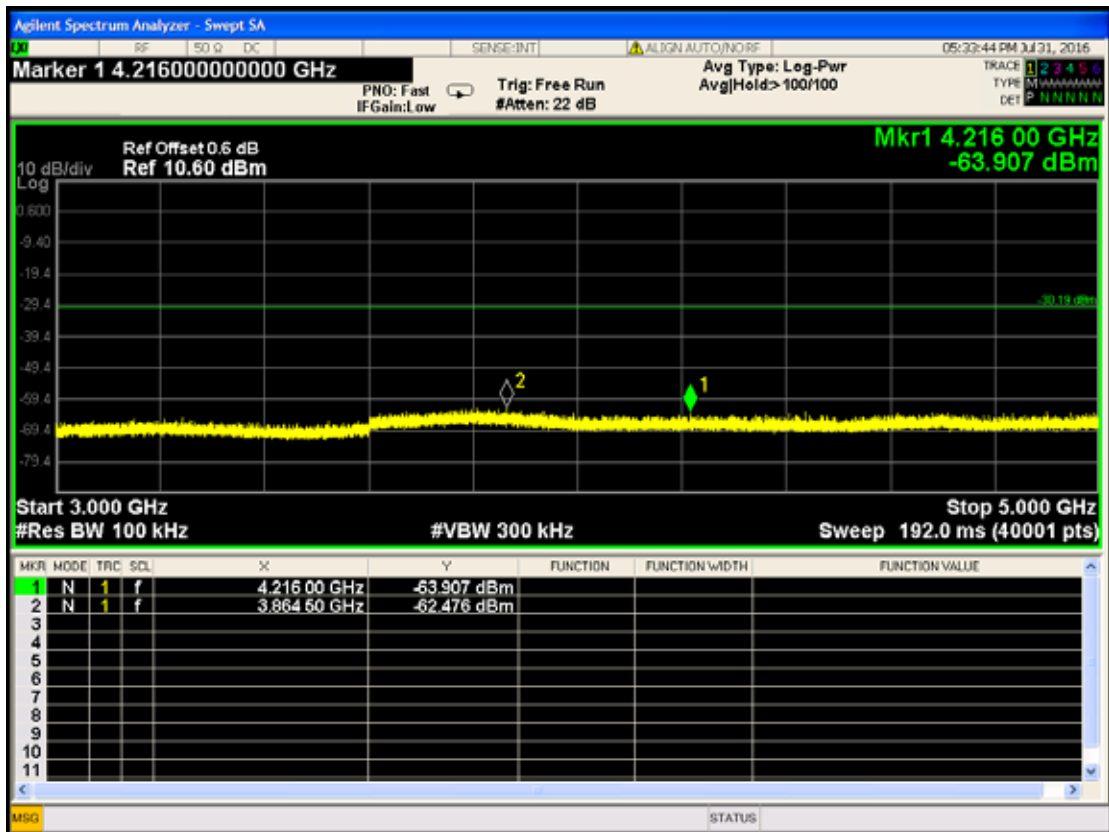
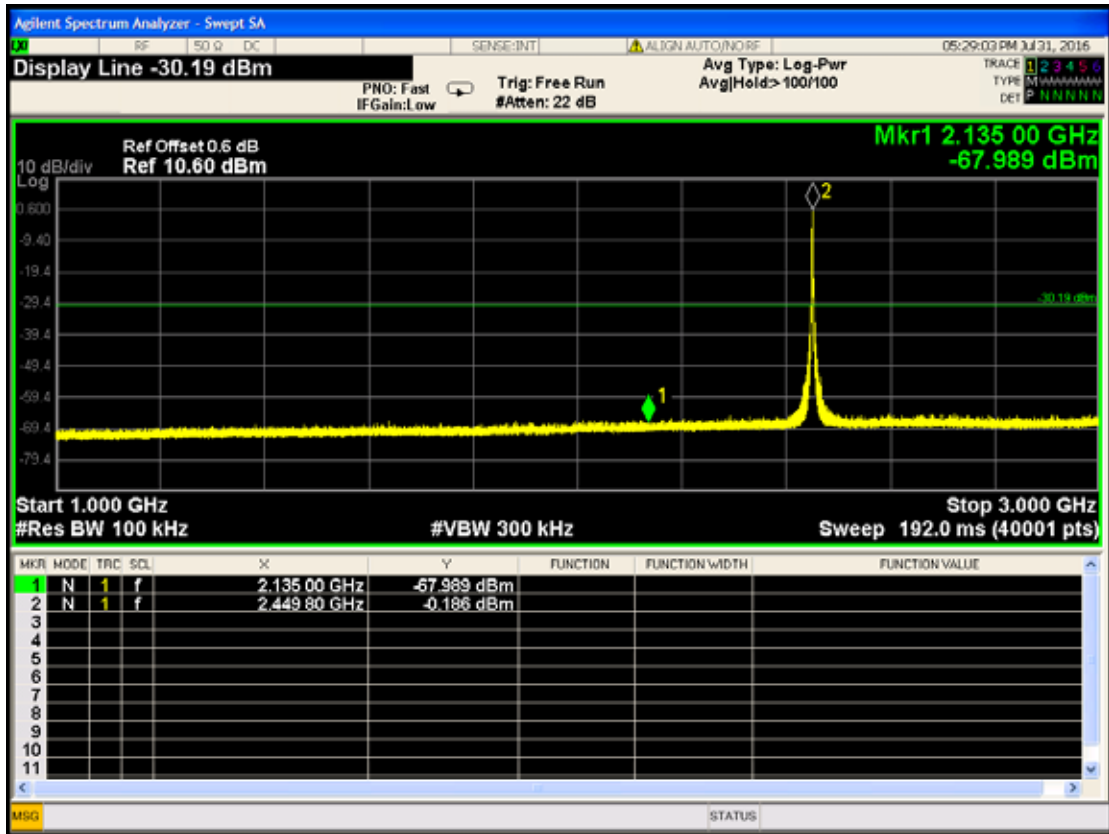

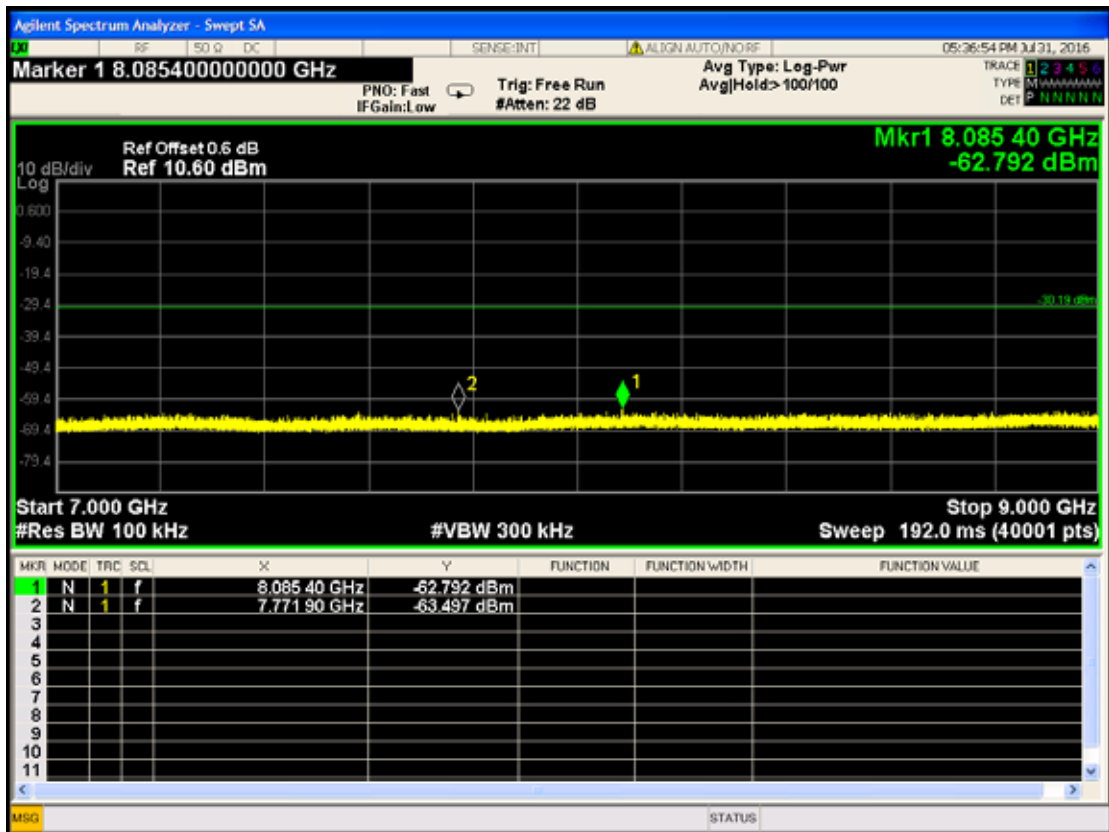
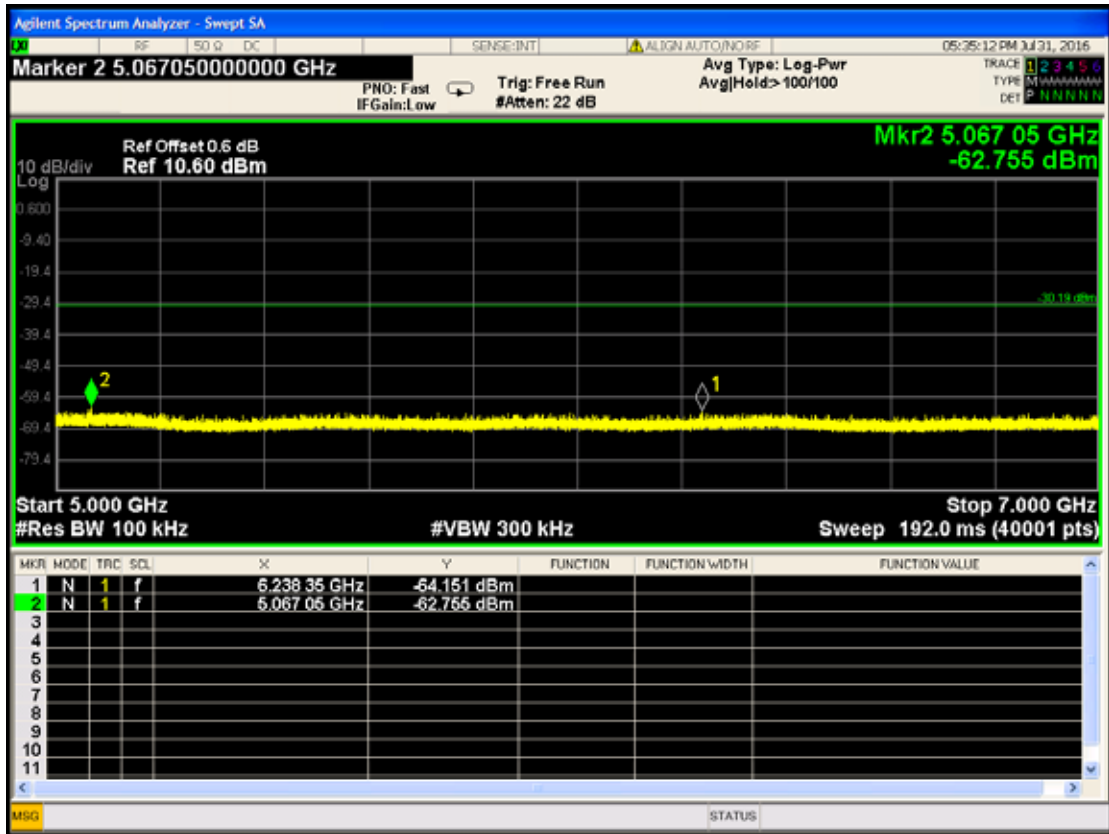

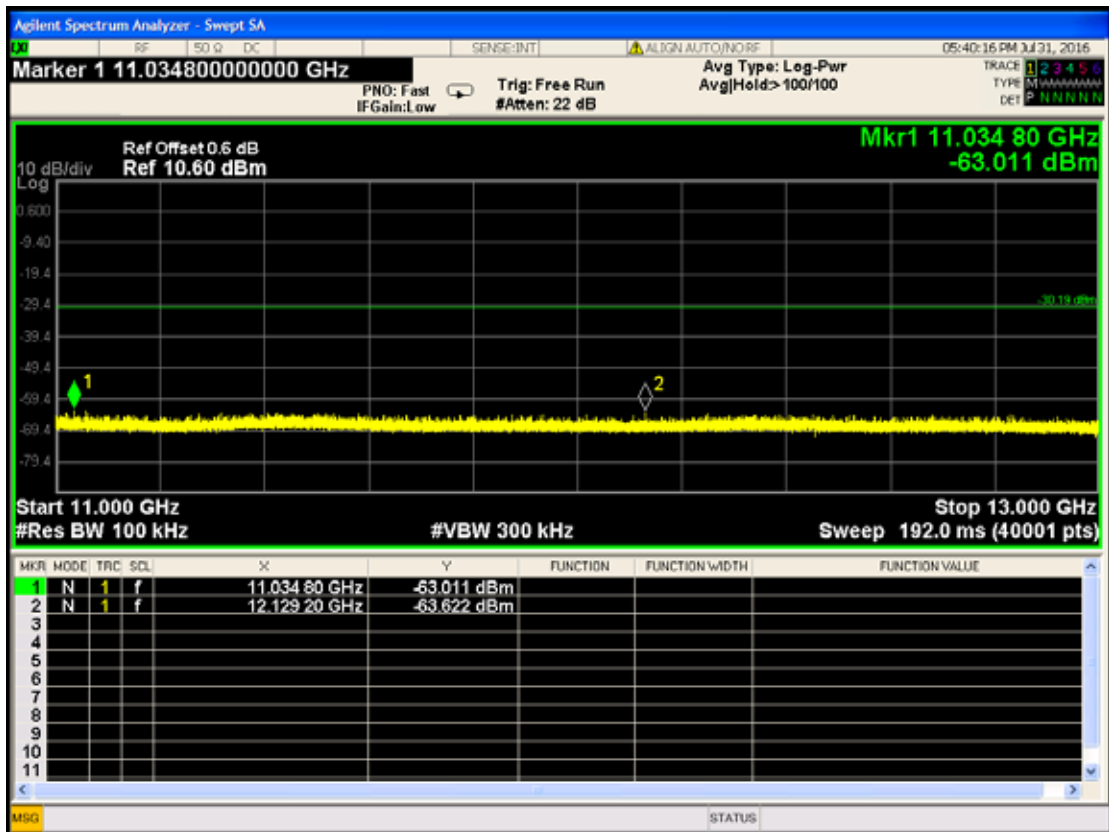
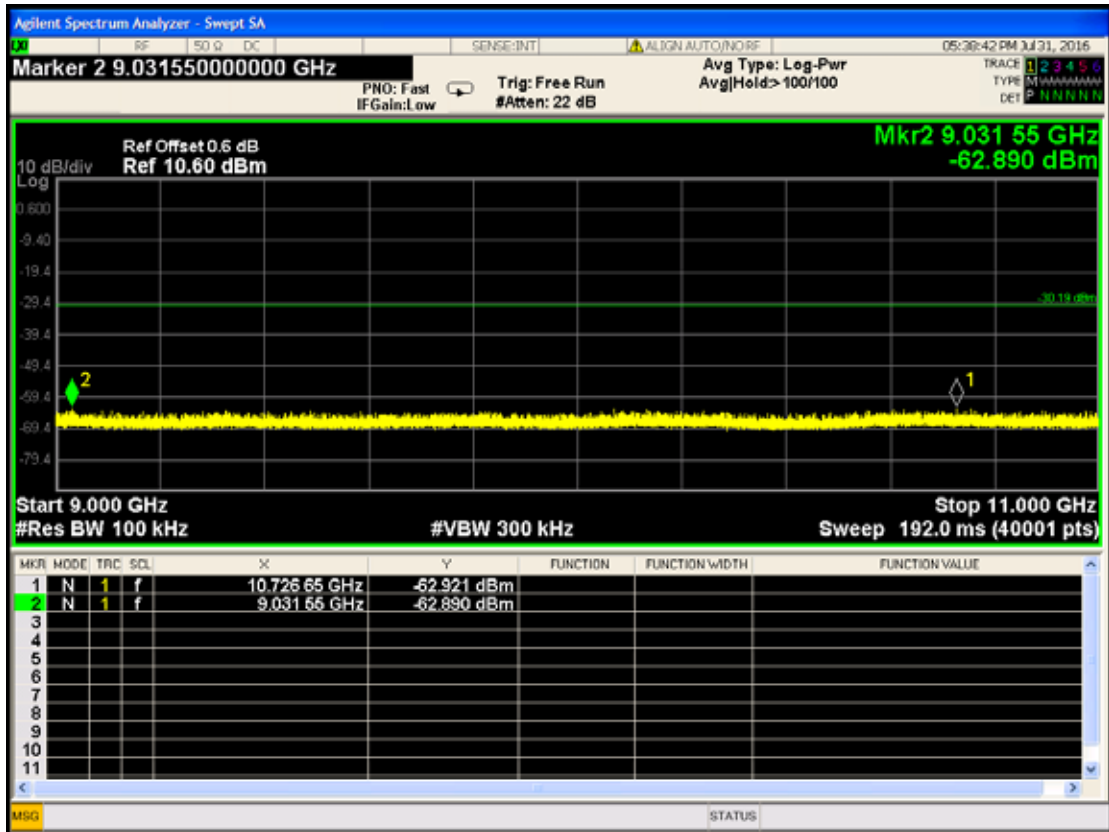

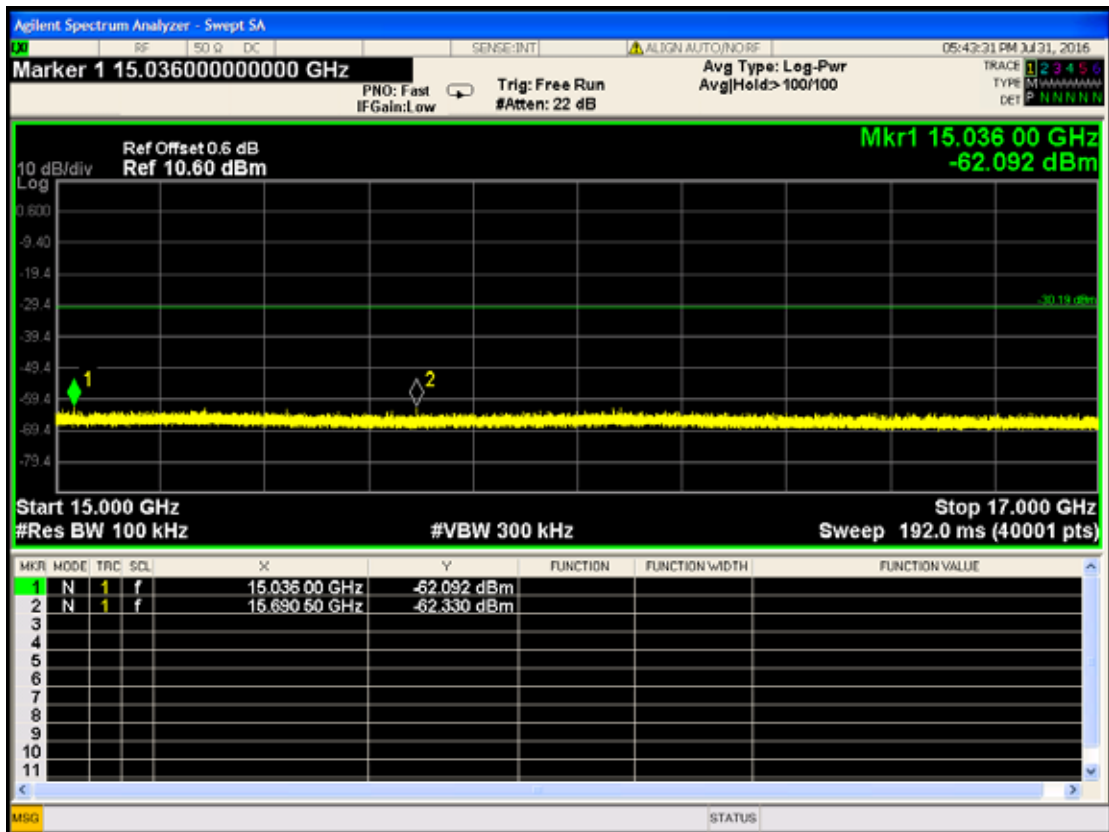
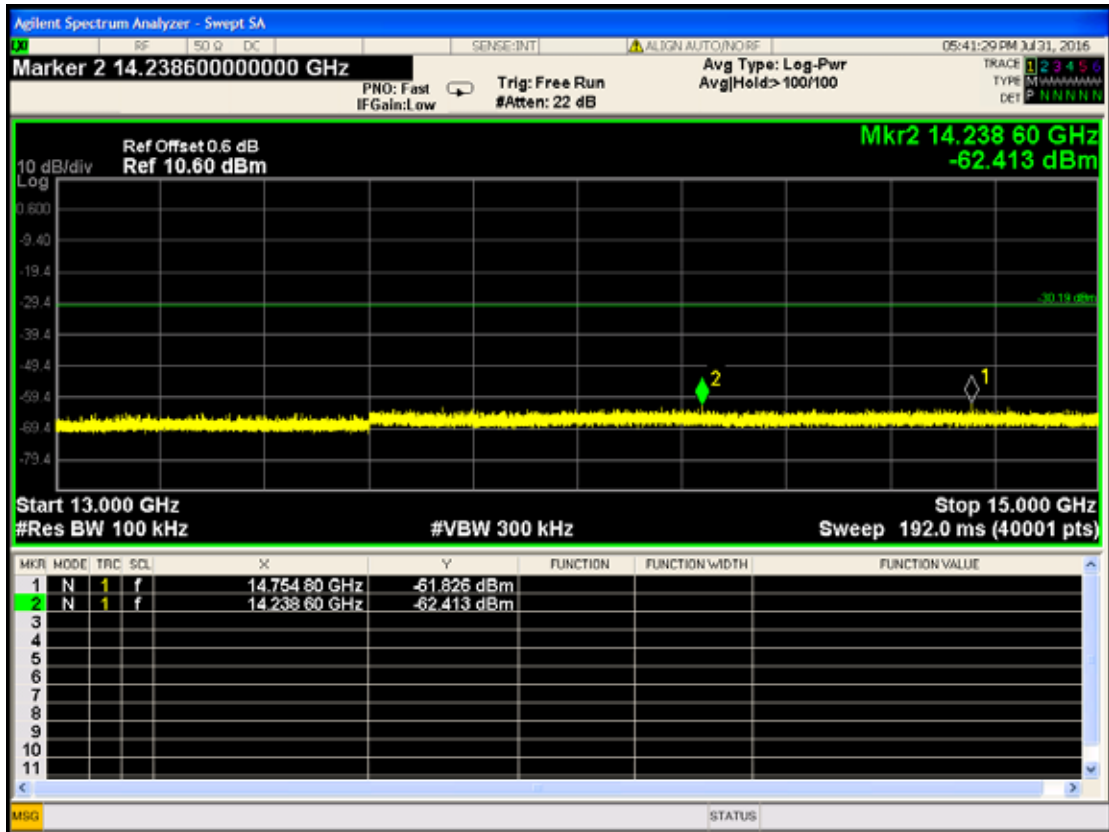

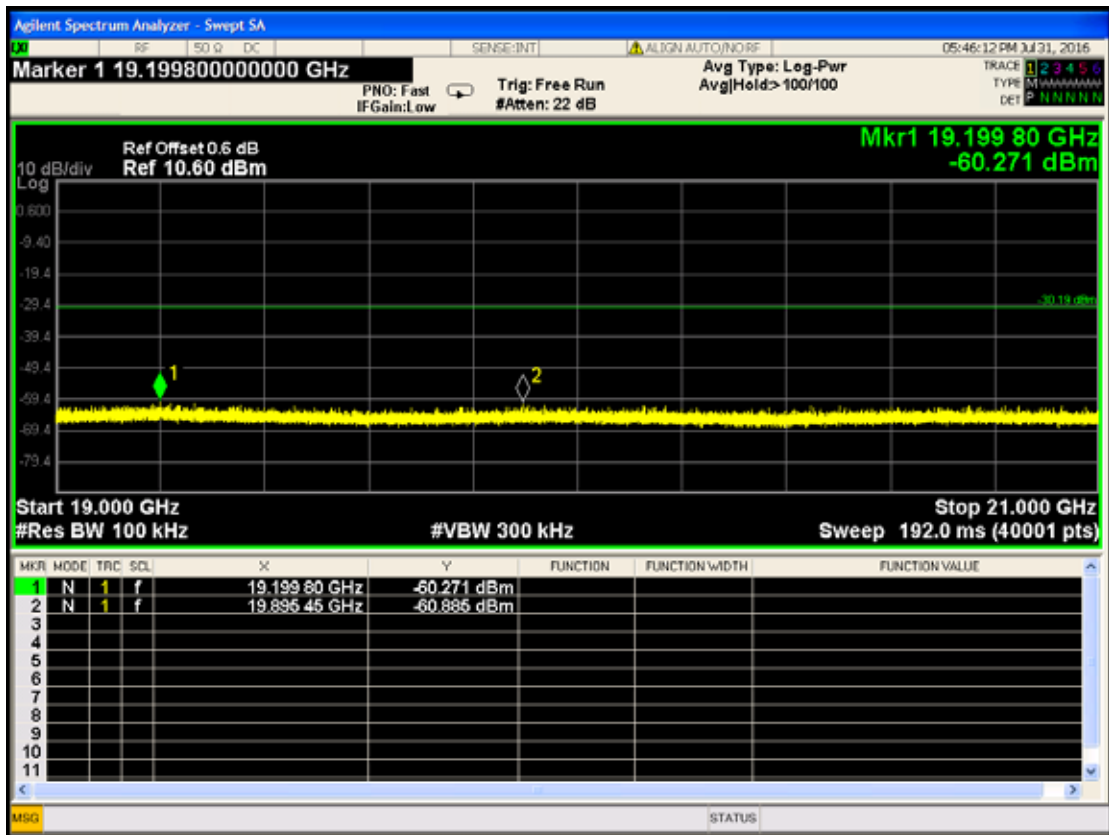
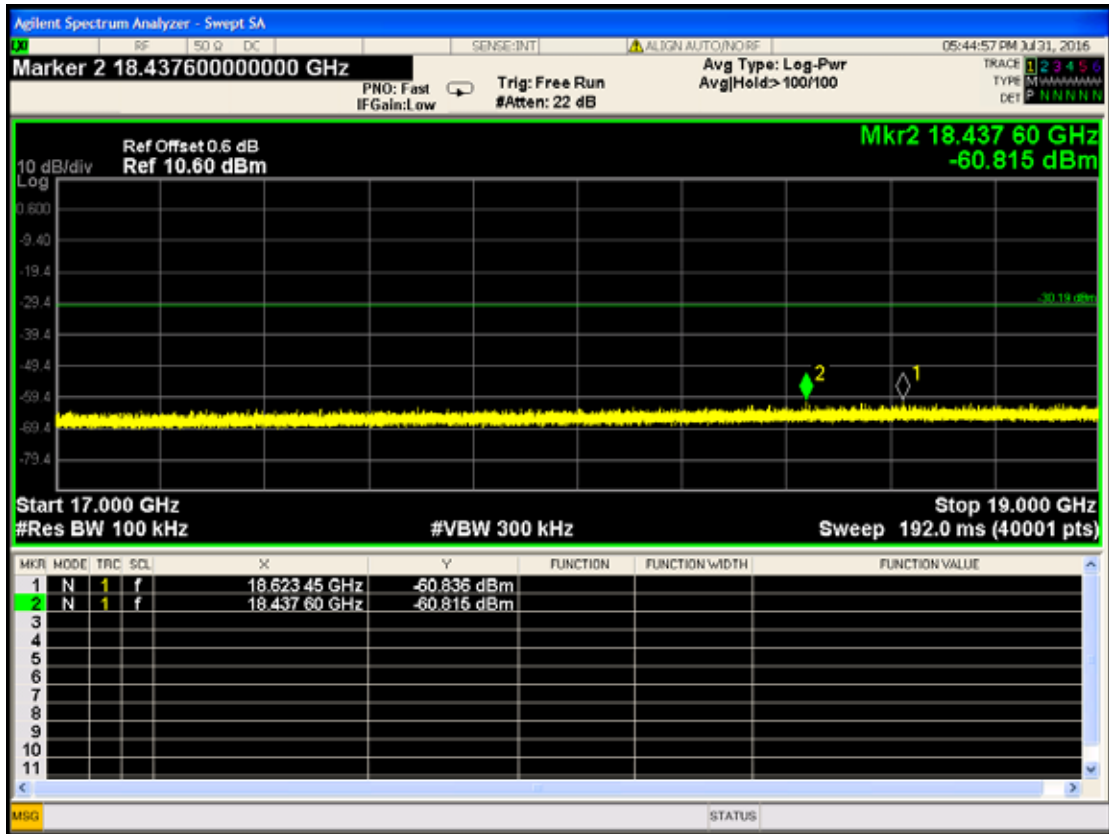

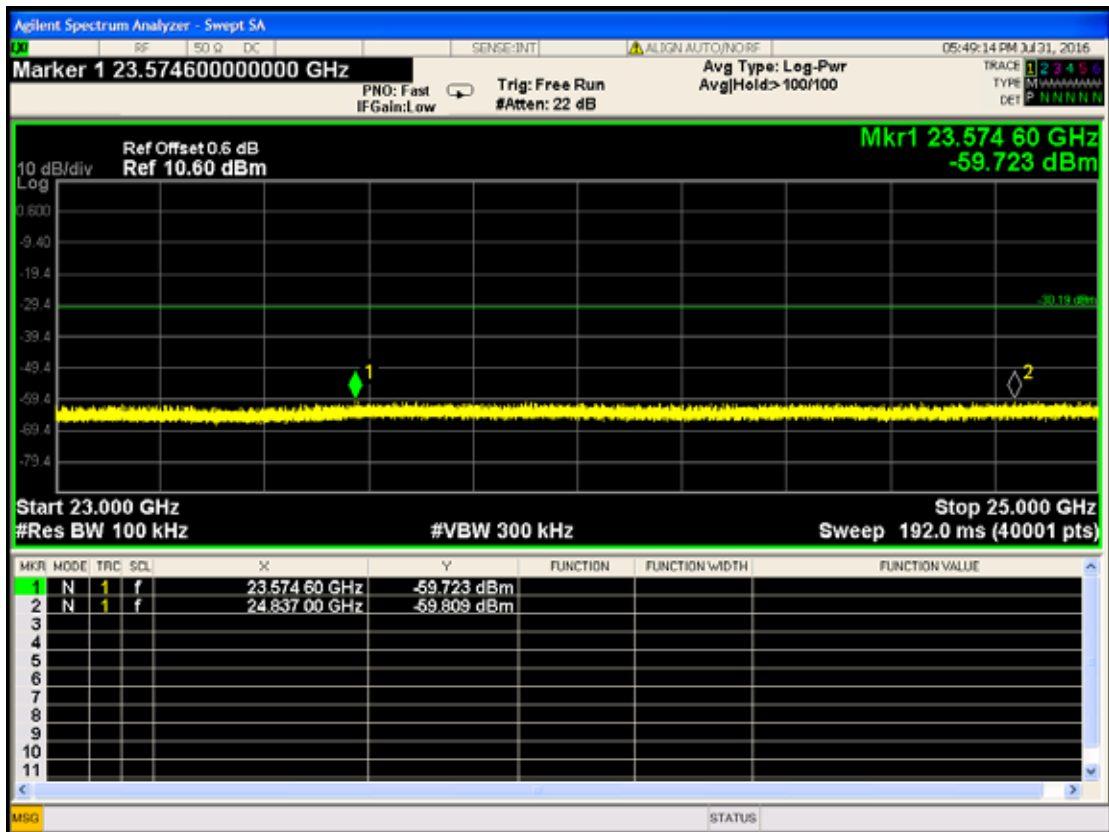
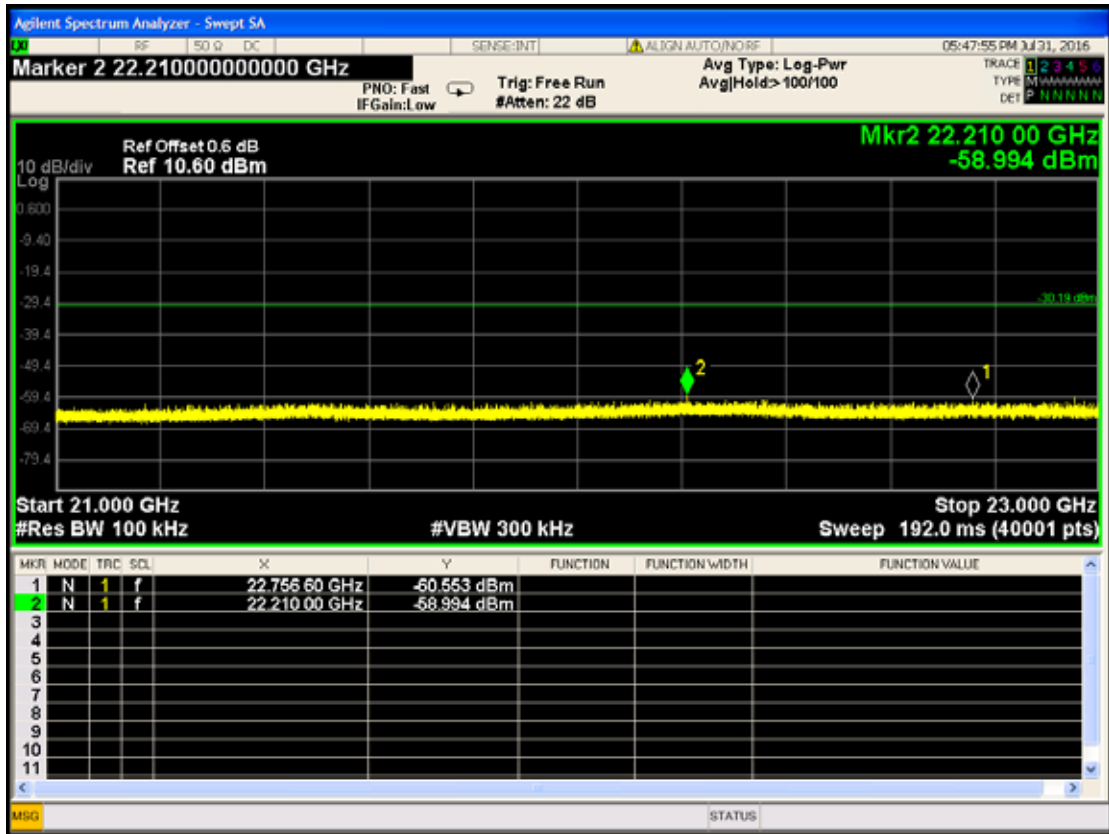

CH 26

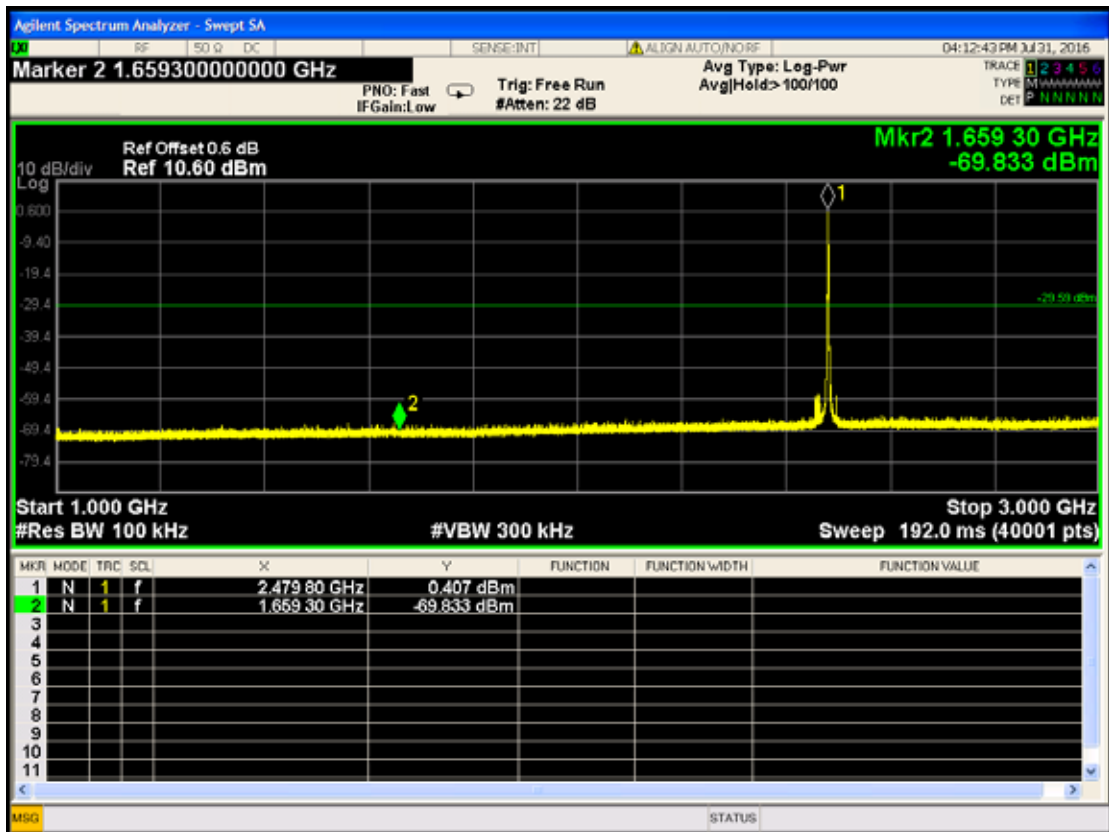
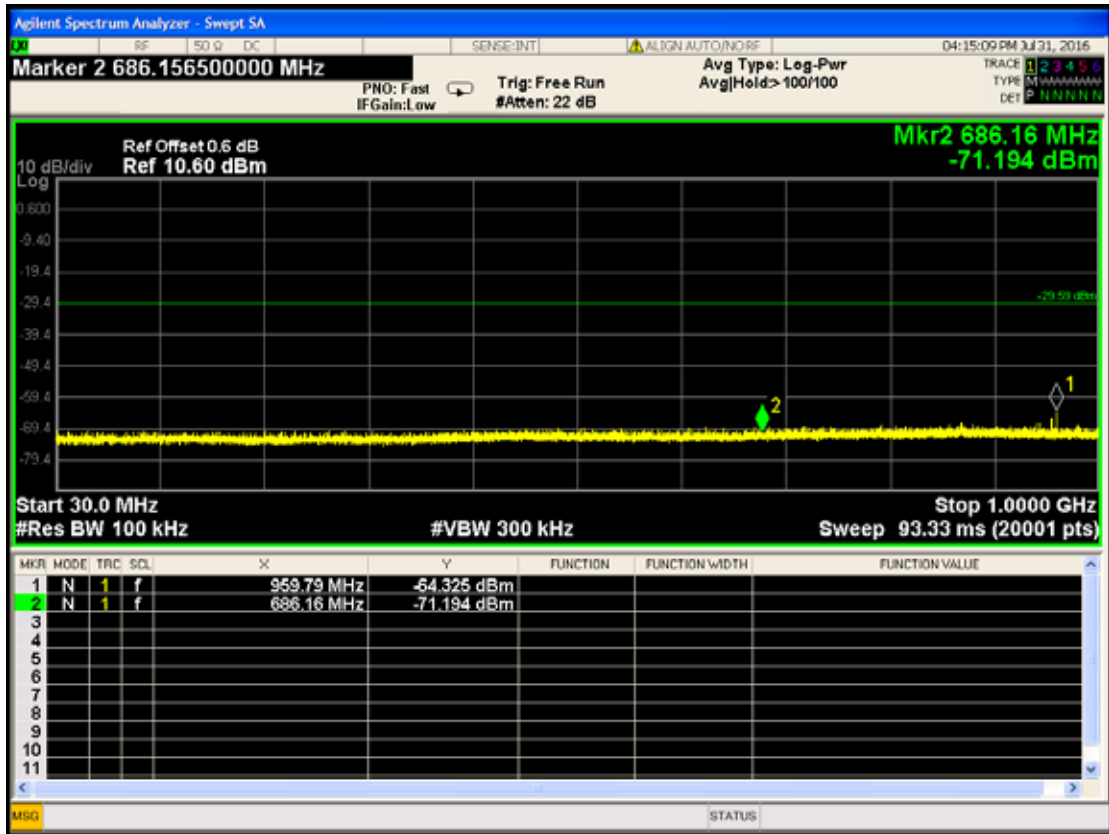

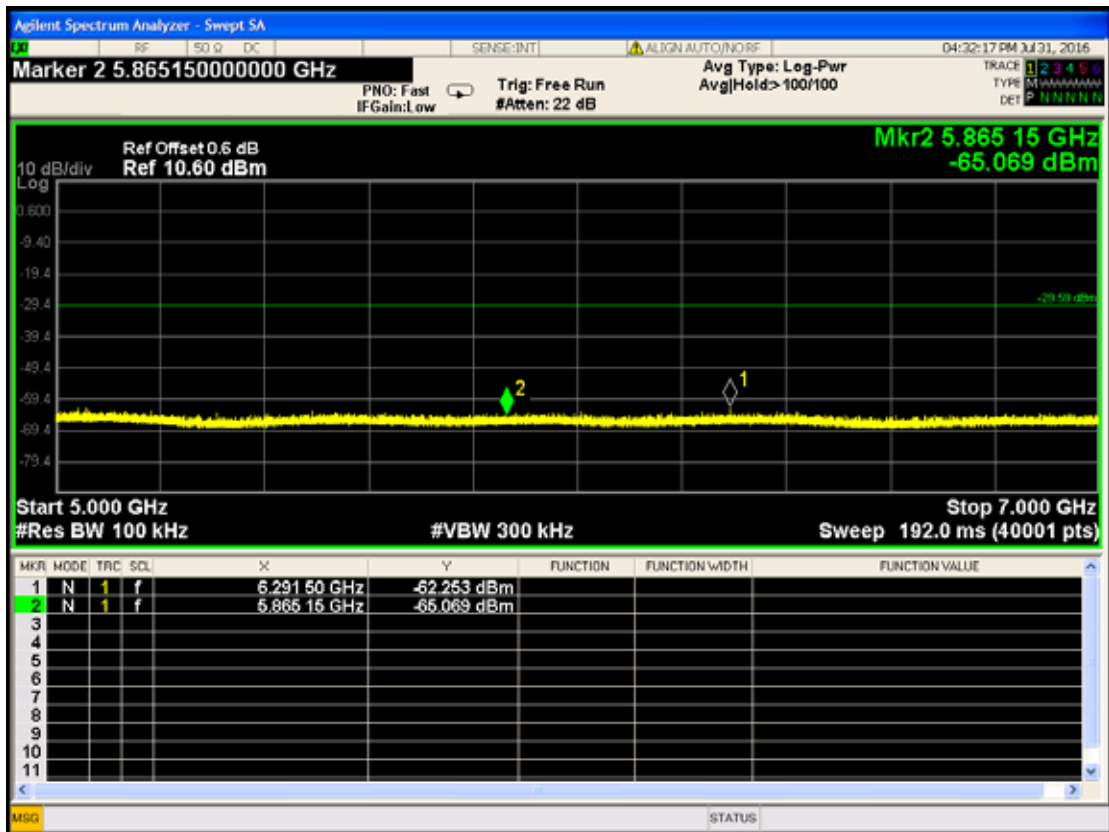
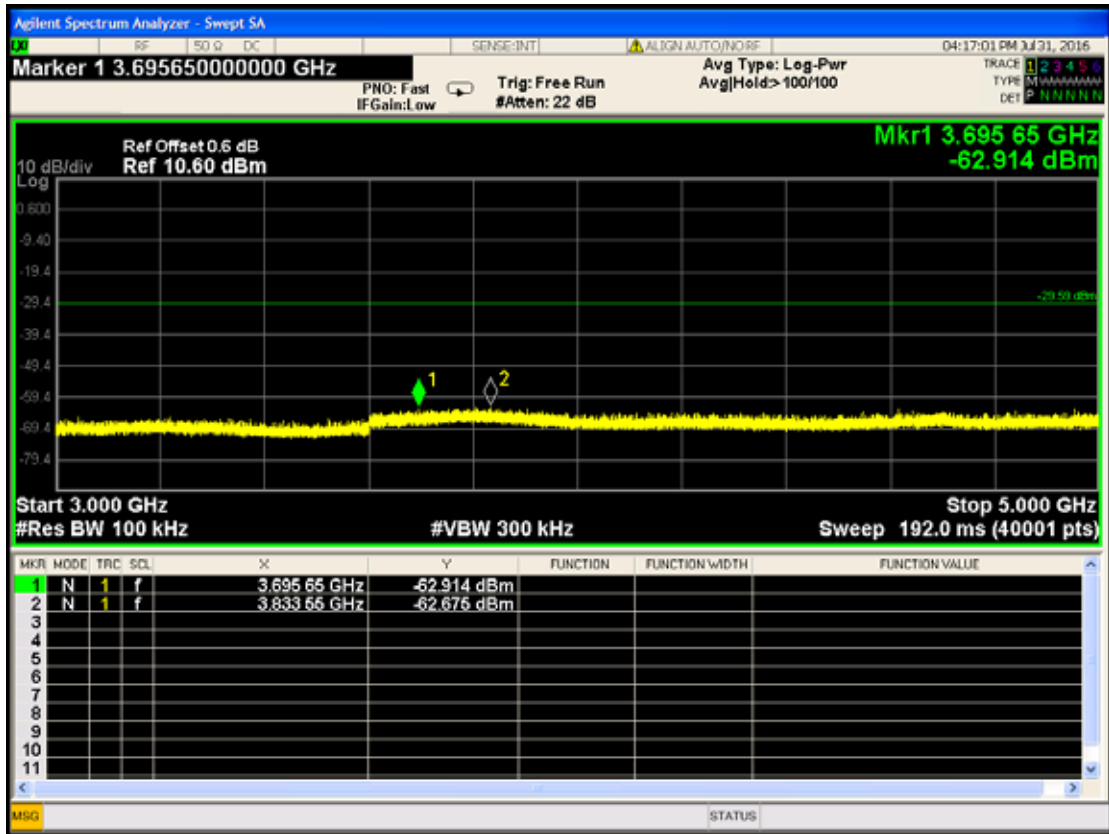

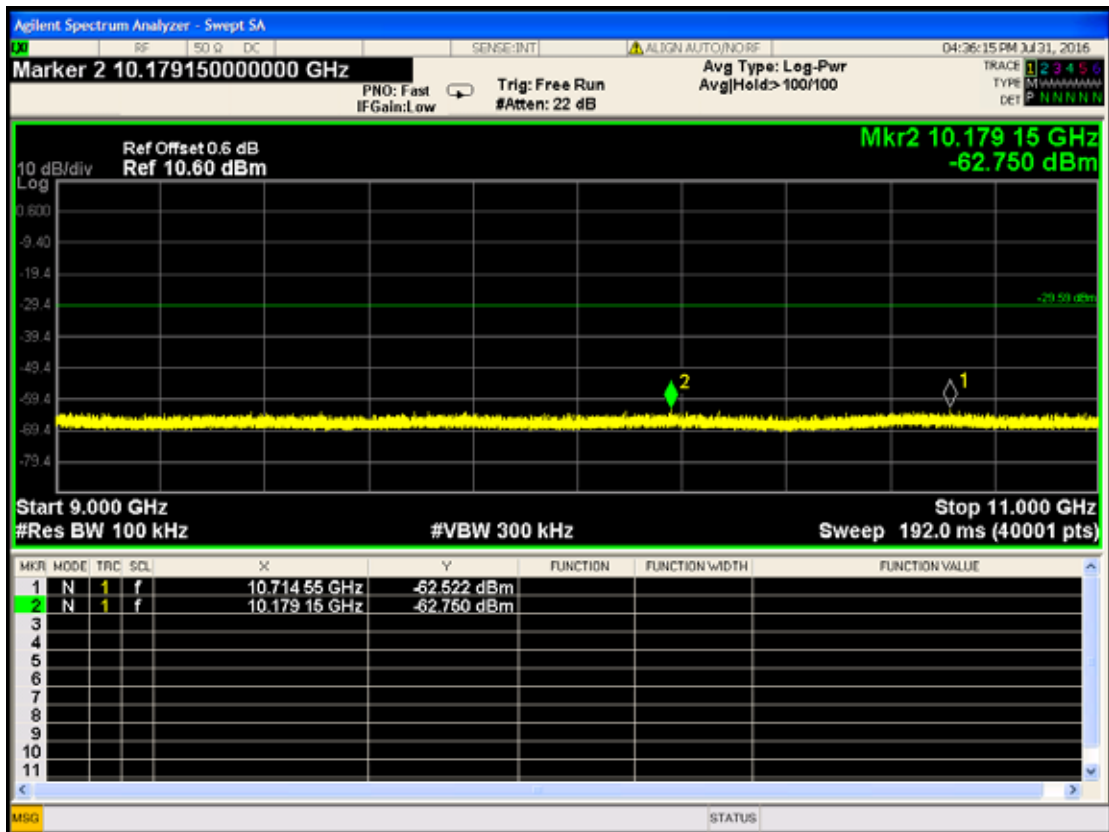
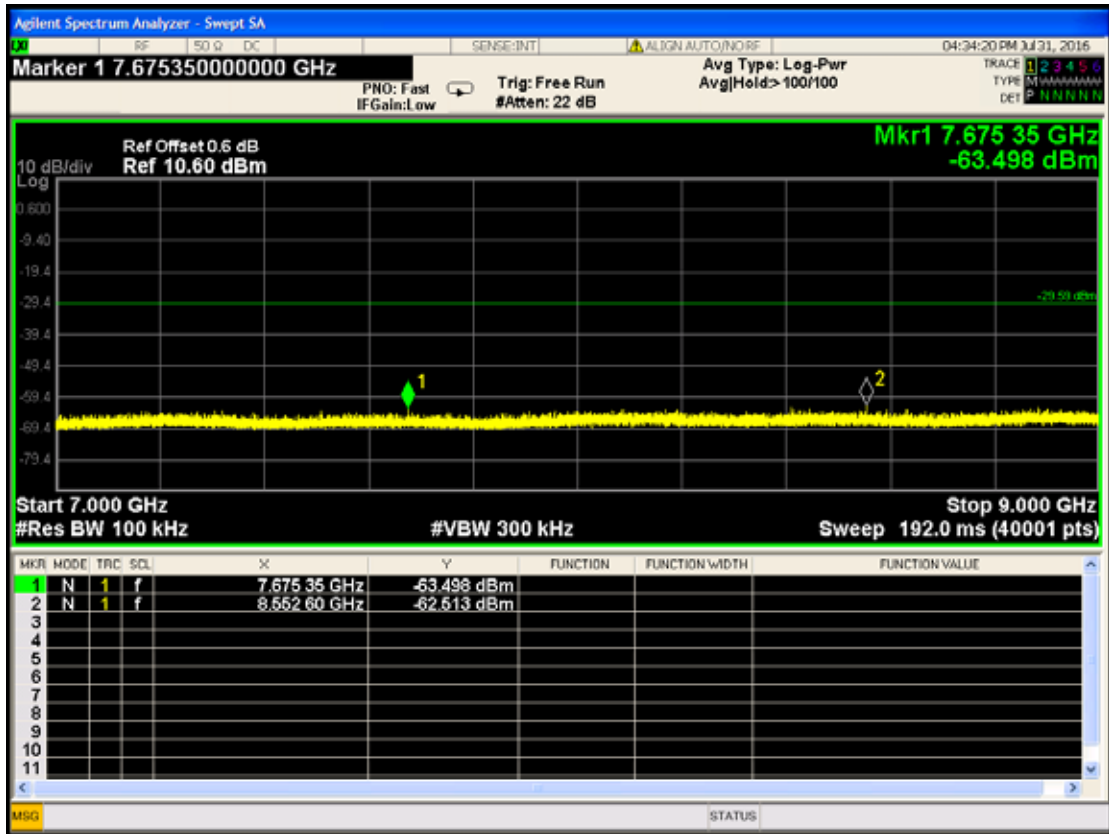

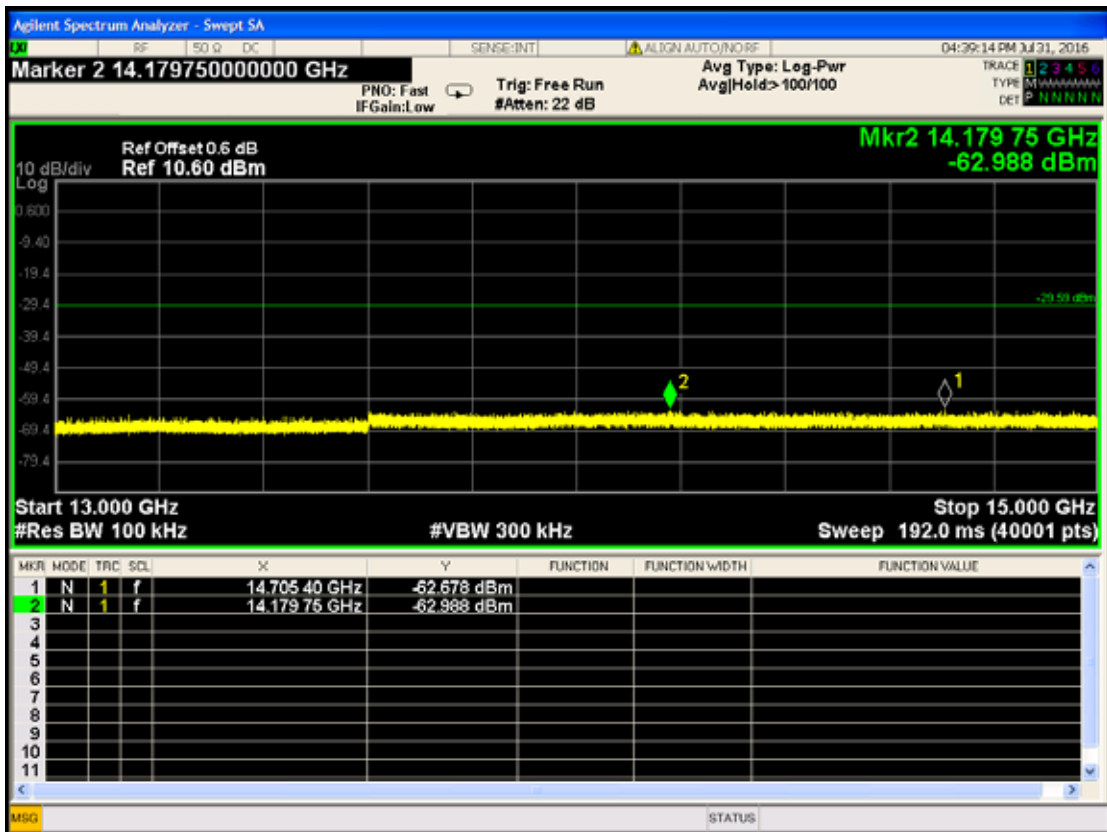
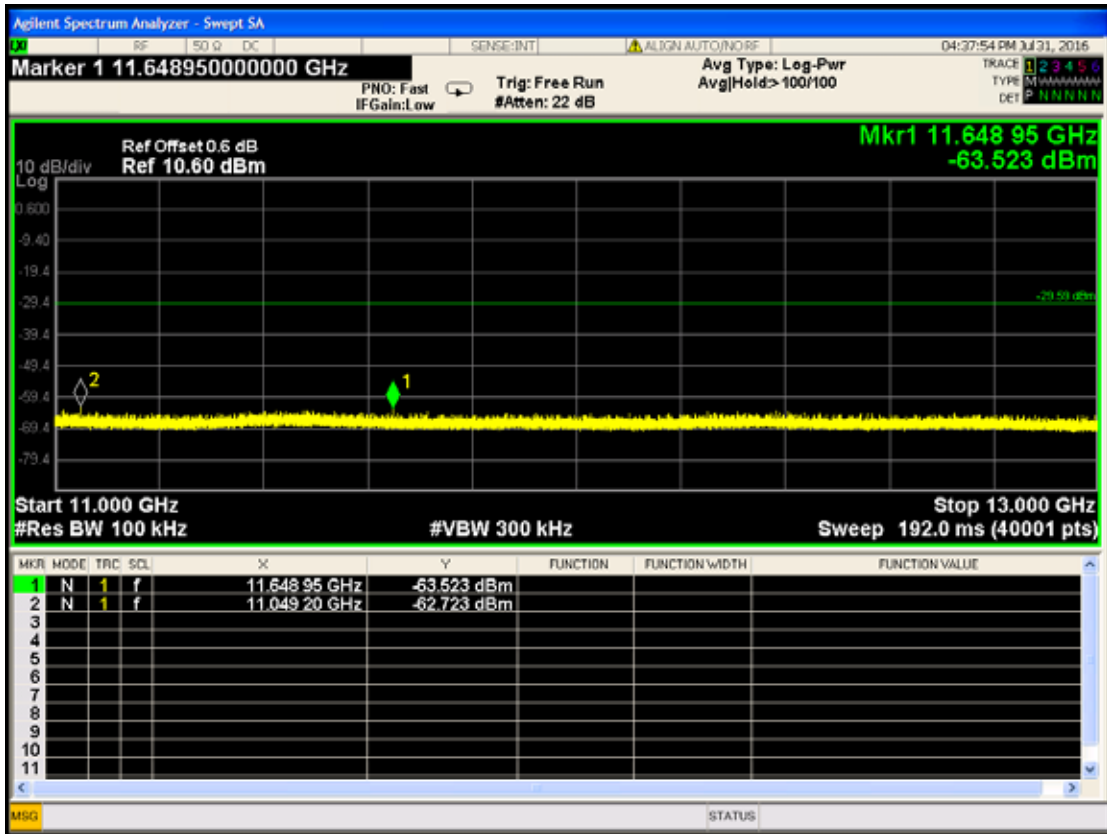

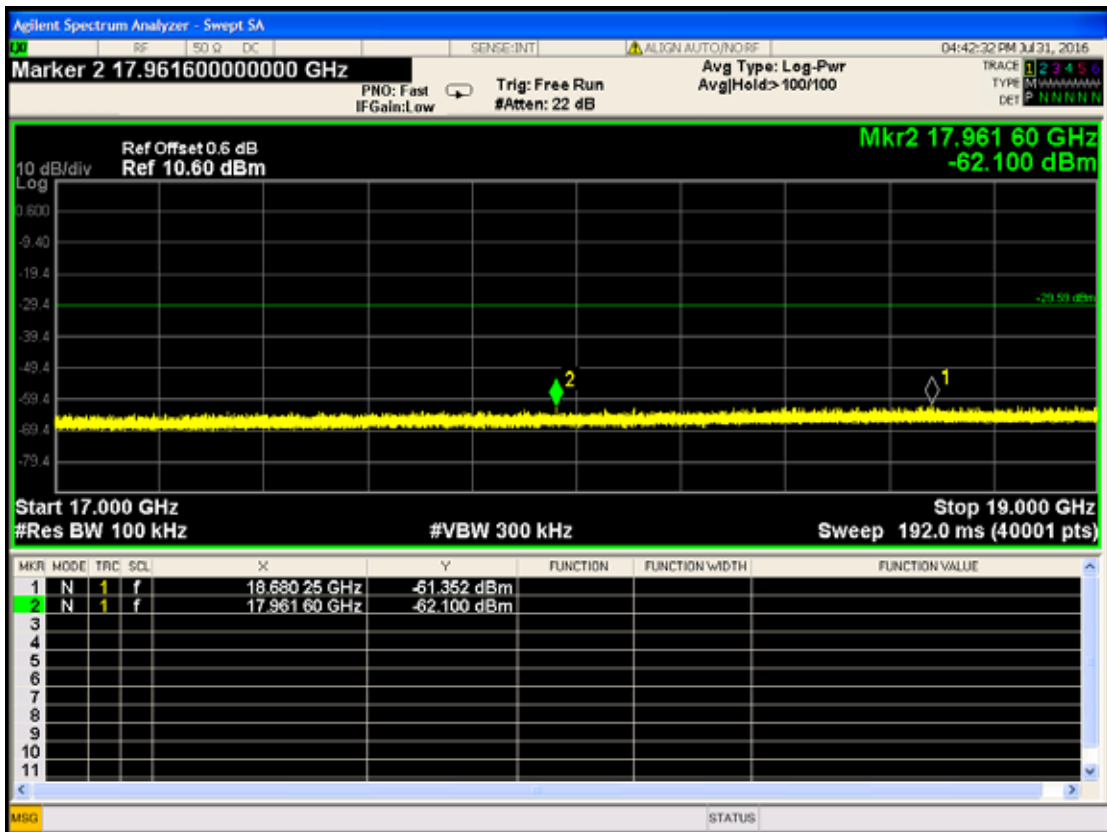
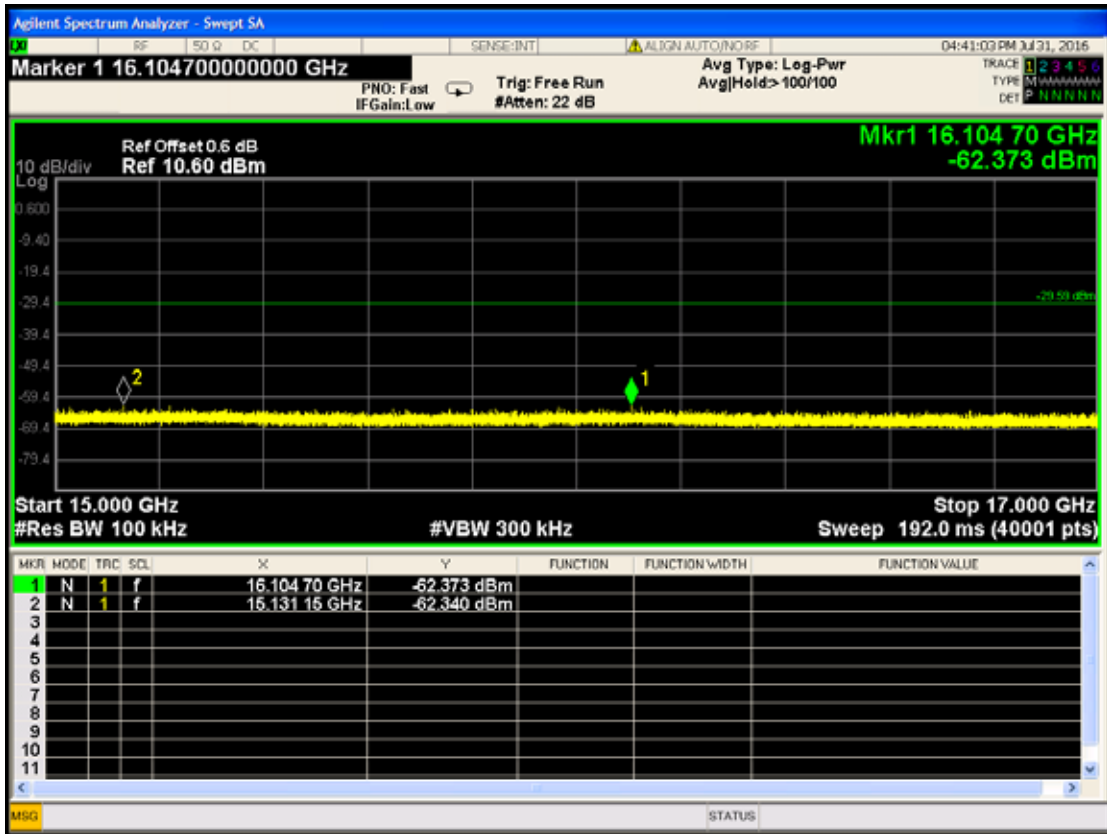

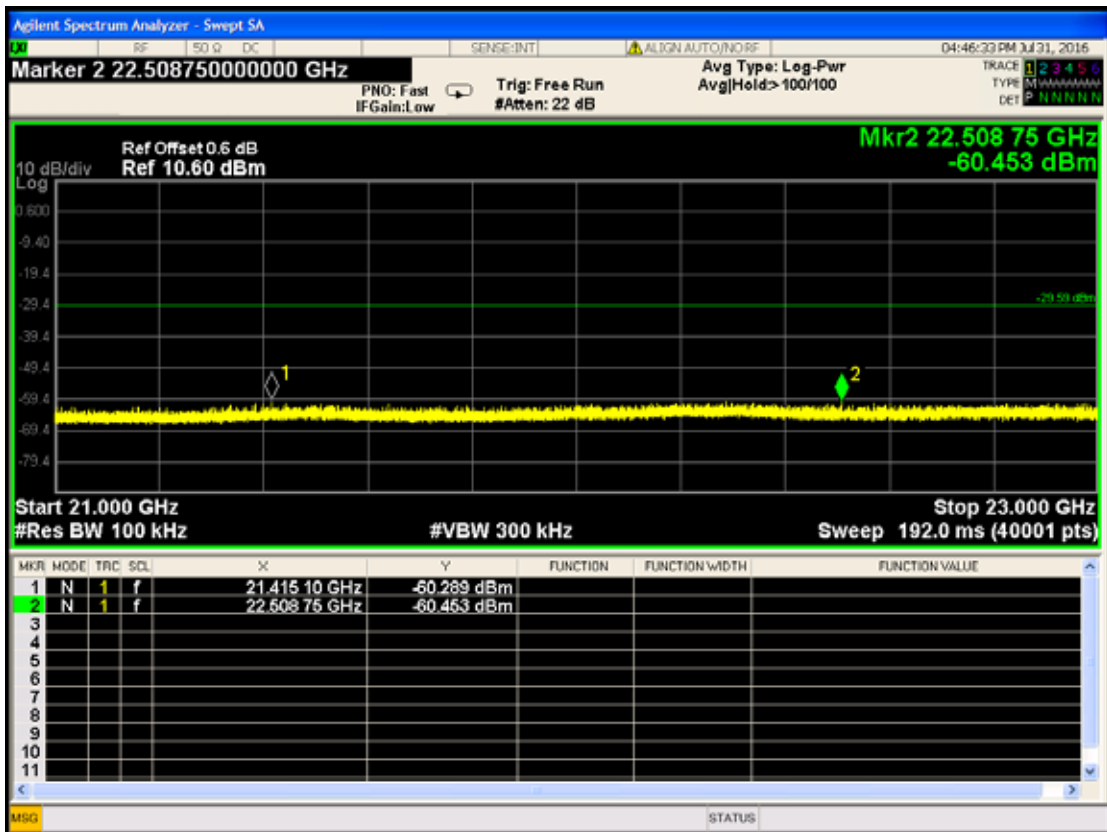
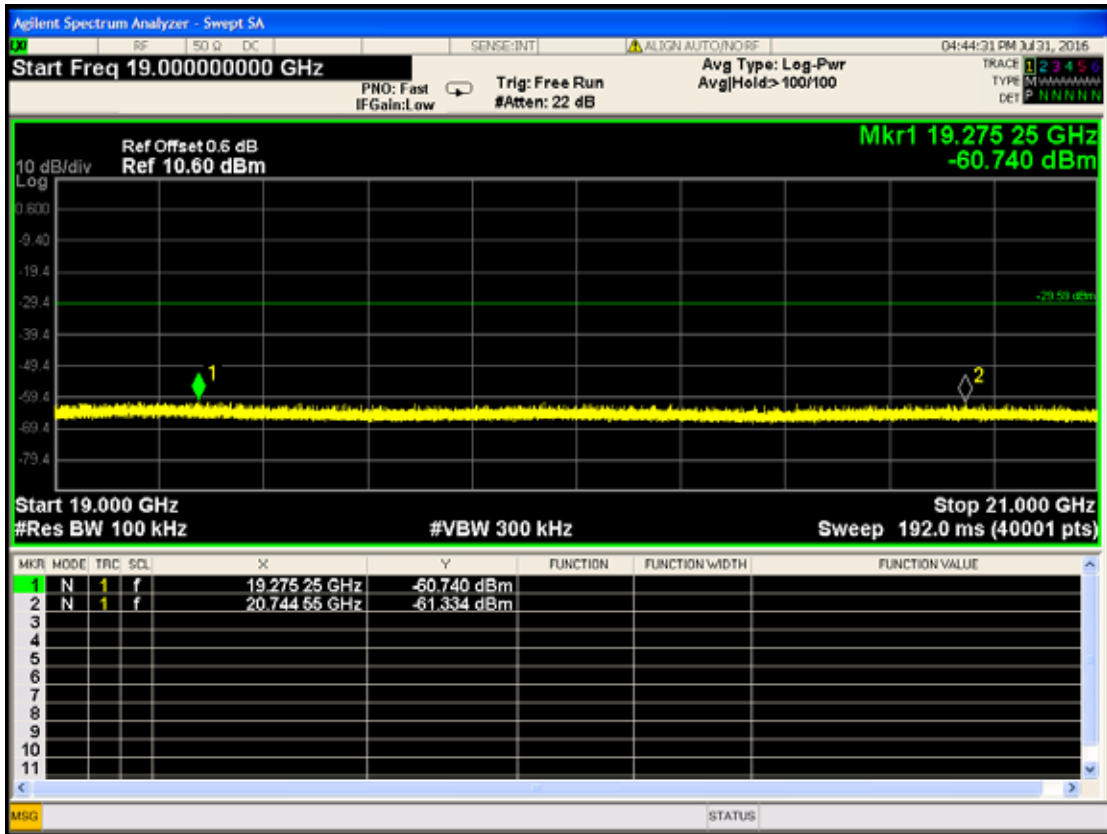

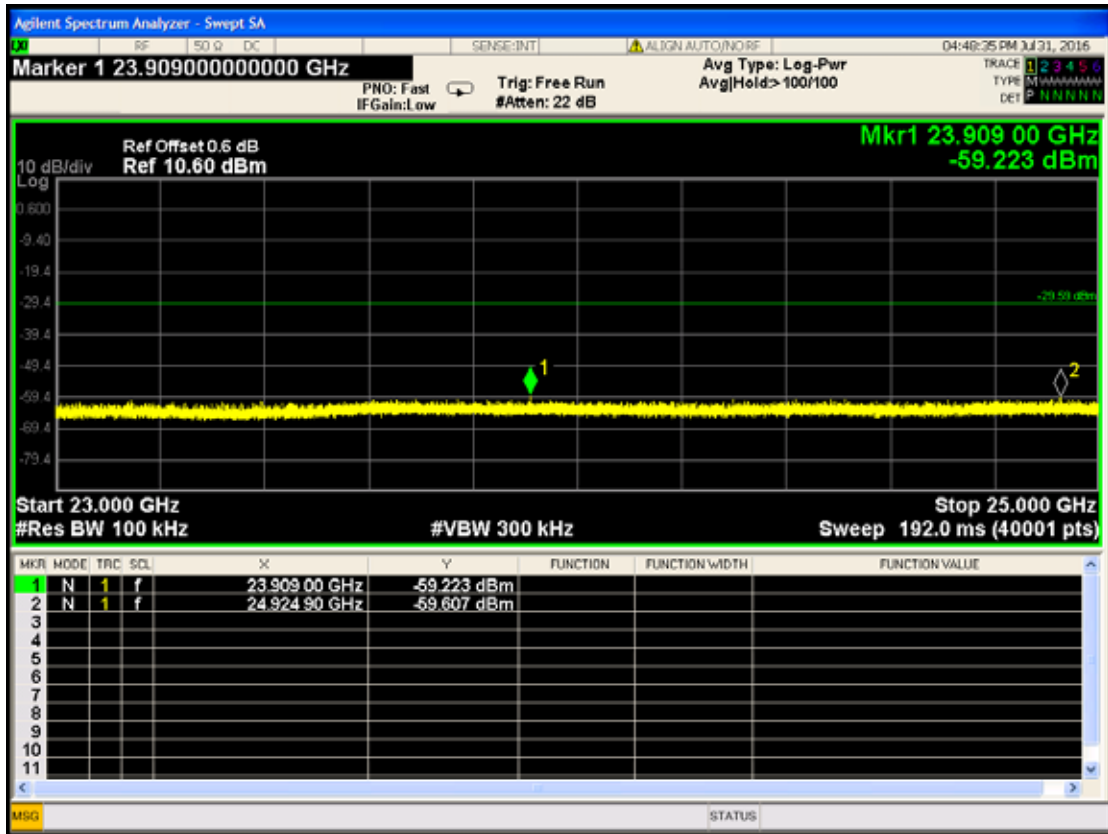

11.DUTY CYCLE

11.1. Test Equipment

Item	Type	Manufacturer	Model No.	Serial No.	Last Cal.	Next Cal.
1.	PXA Signal Analyzer	Agilent	N9030A	MY53120367	2016-05-15	2017-05-14

11.2. Test Results

The measurement of duty cycle is 100%.

CH 11

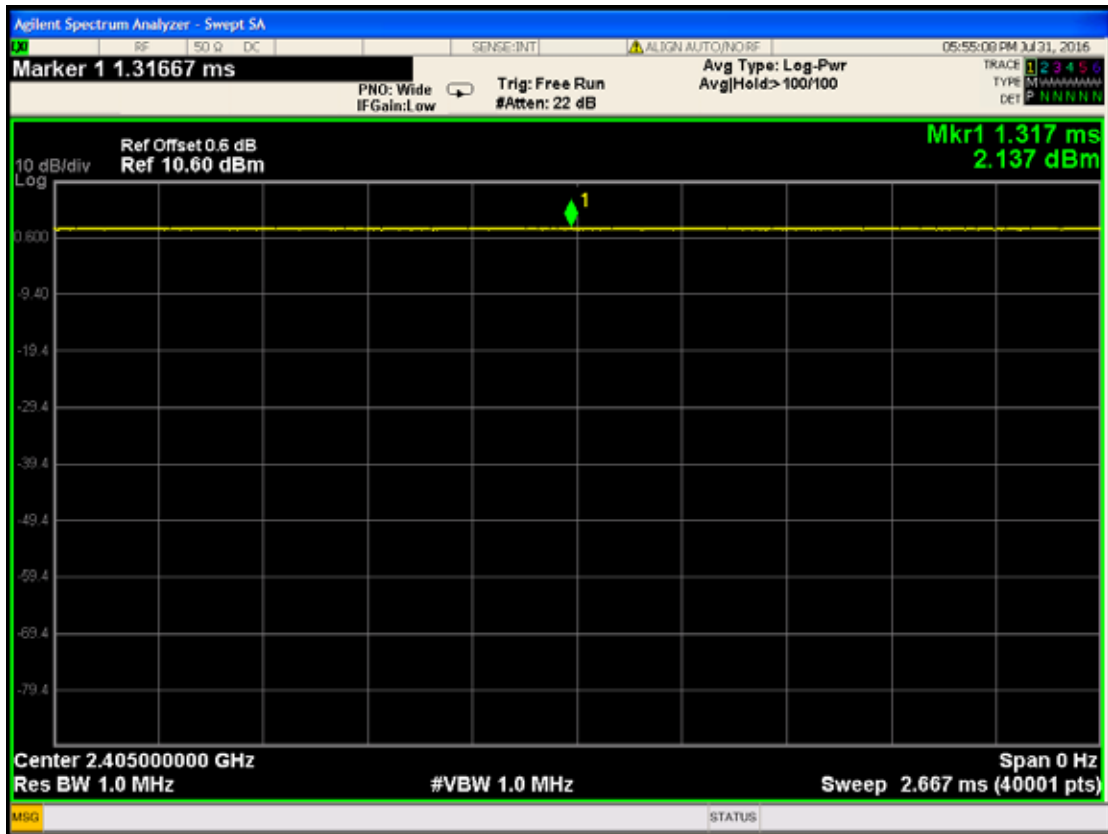

12.DEVIATION TO TEST SPECIFICATIONS

【NONE】