



OontZ

Angle 3 PLUS

Ultra-Portable Bluetooth Speaker
Quick Start Guide

Designed and Engineered By
CAMBRIDGE SOUNDWORKS.

TheOontZ.com

Table of Contents

	Pages
In the Package	1
Play Controls	2
Lights and Connectors	3
Charging the Battery	4 - 5
Battery Features	6
Turning On and Off	7
Pair & Connect - Step 1	8
Pair & Connect - Step 2 --	
-- From Your From Your iPhone, iPad, Smartphone, Tablet and Mobile Devices	9
-- From Your Apple Mac or Windows Laptop/Computer	9
-- From Your Amazon Echo Dot	10 - 11
Playing From Non-Bluetooth Audio Source Devices Using the 3.5mm Audio Cable	12
IPX5 Water Resistant	13
Wireless Hands Free Personal Speakerphone	14
Troubleshooting	15 - 19
Resetting Your OontZ Angle 3 PLUS	20
Customer Support	21
Safety and Precautions	21 - 22

In the Package

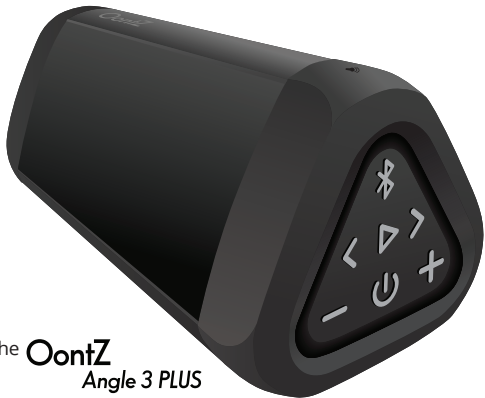

The **OontZ**
Angle 3 PLUS



Quick Start Guide



Micro USB Charging Cable



3.5mm Audio Cable

Note: The Micro USB Charging Cable and the 3.5mm Audio Cable are packed below the cardboard insert in the box. Slide out the cardboard insert to locate the cables.

Play Controls

 **Bluetooth Button (Dual Function)**

 **Track Back**

Press and Release to go to the beginning of the current track. Press and Release a second time to play previous track

 **Volume Down**

Press to decrease volume



 **Play/Pause**

Press and Release to Pause/Play

 **Track Forward**

Press and Release to play next track

 **Volume Up**

Press to increase volume

 **Power Button**

Note:

- Make sure the volume level is set high on your audio source device. The volume on the OontZ Angle 3 PLUS and your audio source device both need to be set to the highest level for the loudest volume. The volume controls on your audio source device and the speaker work independently of each other.
- Some apps may not support track back, track forward, or play/pause

Lights and Connectors

Built-in Mic for Speakerphone

Blue Light when speaker is on:

- **flashing Blue** speaker is in pairing mode
- **solid Blue** speaker is connected

Red Light when charging:

- **slowly flashing Red** charging
- **solid Red** fully charged

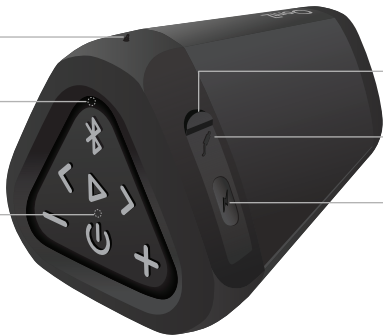

Rubber Flap

pull gently from the top

AUX IN Jack

located under rubber flap

Micro USB Charging Connector

located under rubber flap

Note: The rubber flap needs to be closed to keep the speaker water resistant

Charging the Battery

The rechargeable battery comes with a partial charge and the speaker is ready to play. For maximum playtime, fully charge the battery. You can play while charging.

Red Light when charging:

- **slowly flashing Red** indicates battery is charging
- **solid Red** indicates battery is fully charged



To charge the battery:

Step 1: Pull down the rubber flap from the top to access the Micro USB Charging Connector.

Step 2: Insert the smaller end of the Micro USB Charging Cable into the Micro USB Charging Connector as shown.

Step 3: Insert the other end of the Micro USB Charging cable into either a USB wall charger for a Smartphone or iPhone, or a USB port on your laptop/computer to charge the battery (see illustrations on page 5).

Charging Time:
Up to 8 hours to fully charge a low battery.

Charging the Battery (continued)

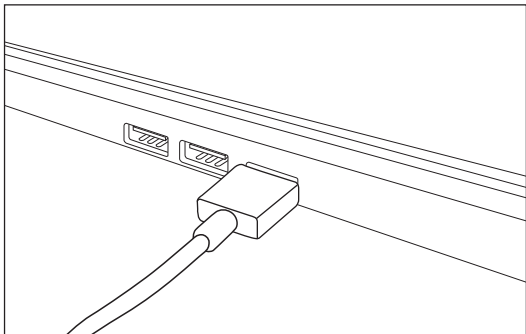
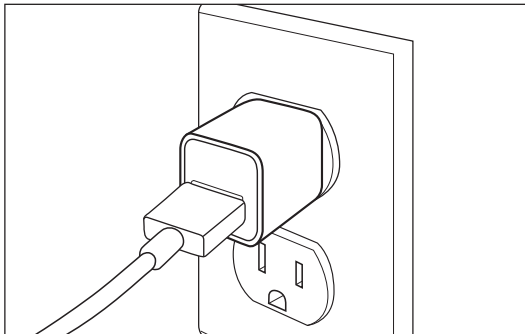

Insert the larger end of the Micro USB charging cable into either a USB wall charger for a Smartphone or iPhone (a USB wall charger that is 5V $\overline{\text{DC}}$ 1.0A up to 5V $\overline{\text{DC}}$ 2.4A maximum) or a USB port on your laptop/computer to charge the OontZ Angle 3 PLUS battery.

Battery Features

You can play the OontZ Angle 3 PLUS while it is charging.

Power Saving Feature

- When playing from battery power the OontZ Angle 3 PLUS will turn off after 15 minutes of not playing audio to conserve the battery charge. *
- When plugged into a charging source the OontZ Angle 3 PLUS will remain on until you turn the power off. You can continue to keep the speaker plugged into a charging source even when it is fully charged.



Low Charge Remaining

When the battery charge has less than 15% remaining the Red Light will begin flashing. The volume will decrease to preserve the remaining battery charge.

*Exception: when connected to an Amazon Echo Dot, the power saving feature is disabled and the speaker will remain on.

Turning On and Off

Blue Light



Power Button

Turn ON

Press and Release the Power Button

- **Blue Light** will turn on

Flashing Blue indicates the speaker is on and in pairing mode

Solid Blue indicates the speaker is on and connected to a source device and ready to play

Turn OFF

Press and Hold Down the Power Button for 2 Seconds

- **Blue Light** will turn off

Pair & Connect -- Step 1

- Make sure your OontZ Angle 3 PLUS battery has a sufficient charge, it is not able to connect when the charge is too low
- Your audio source device needs to be within 33 unobstructed feet of the OontZ Angle 3 PLUS

Turn ON your OontZ Angle 3 PLUS

The Blue Light will turn on.

If the Blue Light is flashing the OontZ Angle 3 PLUS is ready to pair and connect.

If the Blue Light is solid the OontZ Angle 3 PLUS has automatically reconnected to the last audio source device the speaker was connected to and is ready to play.

Note: The OontZ Angle 3 PLUS will automatically try to connect to the last audio source device it was connected to each time it is turned on and that audio source device is within range.

The OontZ Angle 3 PLUS can be connected to one audio source device at a time.

To pair and connect to a different audio source device, you need to first disconnect the currently paired audio source device. To disconnect it, press and hold down the **Bluetooth button** for 2 seconds. The **Blue Light** will begin **flashing** and the OontZ Angle 3 PLUS is ready to pair and connect.

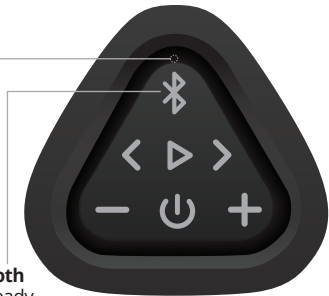

Pair & Connect -- Step 2 --

-- From Your iPhone, iPad, or iPod

- Go to Settings > Bluetooth, check Bluetooth is on
- Select 'OontZ Angle 3 PLUS' when it appears under DEVICES
- The speaker will connect in a few seconds
- The **Blue Light** will turn solid blue
- You can now play your audio wirelessly to your OontZ Angle 3 PLUS

-- From Your Smartphone, Tablet and Mobile Devices

- Go to Settings > Bluetooth, check Bluetooth is on
 - Scan or Search and select 'OontZ Angle 3 PLUS' when it appears under AVAILABLE DEVICES
 - The speaker will connect in a few seconds
 - The **Blue Light** will turn solid blue
 - You can now play your audio wirelessly to your OontZ Angle 3 PLUS
- Note: Your Smartphone or Tablet instructions may vary

Important: Make sure the volume level is set high on your audio source device. The volume on the OontZ Angle 3 PLUS and your audio source device both need to be set to the highest level for the loudest volume. The volume controls on your audio source device and the speaker work independently of each other.

-- From Your Apple Mac or Windows Laptop/Computer

For the pairing and connecting guide for your Apple Mac or Windows laptop/computer, please visit: TheOontZ.com/pairing

Pair & Connect -- Step 2 --

-- From Your Amazon Echo Dot

Turn on your OontZ Angle 3 PLUS first and make sure it is in pairing mode (refer to Page 8)

To pair and connect your OontZ Angle 3 PLUS the first time from the Amazon Echo Dot you need to use the Alexa app on your iPhone, iPad, Smartphone, or Tablet.

First make sure to disconnect any other Bluetooth device from the Amazon Echo Dot. The Amazon Echo Dot can only connect to one Bluetooth device at a time.

- Open the Alexa app
- Go to the 'Home' menu by pressing the 3 horizontal lines in the upper left corner next to 'Home'
- Press 'Settings'
- Select your Amazon Echo Dot under 'Devices' by pressing it
- Press 'Bluetooth'
- Press 'Pair a New Device'. In a few seconds the 'OontZ Angle 3 PLUS' will appear in the list of 'Available Speakers'
- Select 'OontZ Angle 3 PLUS'
- In a few seconds you will hear Alexa's voice coming through the OontZ Angle 3 PLUS: "Connected to OontZ Angle 3 PLUS"
- The audio from the Amazon Echo Dot will now play through the OontZ Angle 3 PLUS

Pair & Connect -- Step 2 --

-- From Your Amazon Echo Dot (continued)

Now that the Amazon Echo Dot is paired to the OontZ Angle 3 PLUS, if the speaker becomes disconnected or turned off, to re-connect turn on the OontZ Angle 3 PLUS and just say "Alexa, connect my speaker " or "Alexa, pair"

Important Note: When the OontZ Angle 3 PLUS is playing from battery power and connected to the Amazon Echo Dot, the Amazon Echo Dot disables the power saving feature on the OontZ Angle 3 PLUS. The speaker will remain on and it will not automatically turn off after 15 minutes of not playing audio. The Amazon Echo Dot is continuing to communicate to the speaker even when not playing audio and will use up the battery charge, at the same rate as full volume audio.

We recommend either: 1) Keeping the OontZ Angle 3 PLUS plugged into a USB wall charger or USB port on a laptop/computer, so it can remain on and available to play from the Amazon Echo Dot, without having the battery becoming drained. Or, 2) Turning the OontZ Angle 3 PLUS off when you are done listening. You can turn the OontZ Angle 3 PLUS off by pressing and releasing the Power button on the OontZ Angle 3 PLUS, or you can say "Alexa, disconnect my speaker" and the OontZ Angle 3 PLUS will automatically turn off after 15 minutes. When you want to play to the speaker again turn on the OontZ Angle 3 PLUS and say "Alexa, connect my speaker " or "Alexa, pair" and the Amazon Echo Dot will connect and the audio will play through the OontZ Angle 3 PLUS.

If you need assistance with your Alexa app, contact Amazon's support through the app.
Open the Alexa app and select Help & Feedback > Email Customer Service

Playing From Non-Bluetooth Audio Source Devices Using the 3.5mm Audio Cable

- Make sure your OontZ Angle 3 PLUS battery has a sufficient charge

Plug one end of the included 3.5mm audio cable into the **AUX IN Jack** on the back of your speaker.

Plug the other end of the 3.5mm audio cable into the headphone jack on your non-Bluetooth audio device.

You are now ready to play.



Note: The Bluetooth on the OontZ Angle 3 PLUS is disabled when the 3.5mm audio cable is connected to the speaker. You need to remove the 3.5mm audio cable from the speaker in order to connect to a Bluetooth audio source device.

IPX5 Water Resistant

No more worries about the rain or getting splashed

Listen to music in the shower

Perfect for taking to the beach or by the pool



**Gentle Water Spray
or Splash is okay**



**DO NOT allow speaker
to sit in water**



**DO NOT allow speaker
to submerge fully or
partially in water**

IPX5 rating - The OontZ Angle 3 PLUS can resist gentle water spray & splash but cannot be partially or fully submerged or left in a wet environment for an extended period of time, any of which could cause unreparable damage to the speaker

Note: The rubber flap needs to be closed to keep the speaker water resistant. When charging or using the 3.5mm audio cable, please keep the speaker away from water as it can be damaged by water entering the connectors.

Wireless Hands Free Personal Speakerphone

**Bluetooth Button
(Dual Function)**

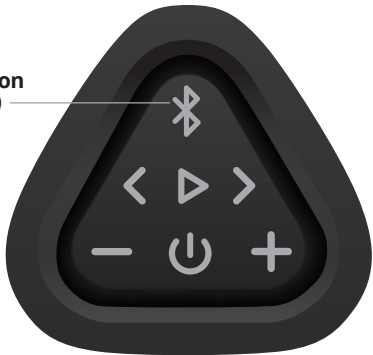

The Wireless Hands Free Personal Speakerphone feature works for calls with Smartphones and iPhones only, connected over Bluetooth.

To answer an Incoming Call / To End a Call

Press and Release the  Bluetooth Button

To Reject an Incoming Call

Press and Hold Down the  Bluetooth Button for 3 Seconds

Please keep the speaker close in front of you so you may be heard clearly by the listener.

You can use your Smartphone or iPhone to switch between using Hands Free Speakerphone and your phone.

Troubleshooting

For the most up to date troubleshooting tips please visit: TheOontZ.com/troubleshooting/oontz-angle-3-plus

OontZ Angle 3 PLUS will not turn on

- The battery may have become fully drained. Charge the OontZ Angle 3 PLUS using a USB wall charger from a Smartphone/iPhone or tablet for at least 15 minutes, then press the power button to turn the speaker on. Then continue charging the battery.
 - Reset the OontZ Angle 3 PLUS, follow the reset instructions on page 20.
-

Cannot pair or connect to the OontZ Angle 3 PLUS

- Check that your OontZ Angle 3 PLUS has a sufficient battery charge, the speaker may not connect when the battery has a low charge. Connect the speaker to a charging source and try again to pair and connect.
- Your source device may be out of range. Move it closer to within 30 unobstructed feet of your speaker.
- Check the Blue Light to make sure it is flashing. If it is solid blue the OontZ Angle 3 PLUS is already connected to another source device. The OontZ Angle 3 PLUS can be connected to one source device at a time. You need to disconnect the connected source device then you can connect to the next source device. Please see instructions on page 8.
- Your source device or the speaker may have a temporary Bluetooth connection issue, please try the following steps which can resolve this:
(continued next page)

Troubleshooting

Cannot pair or connect to the OontZ Angle 3 PLUS (continued)

-- For iPhone, iPad, iPod

- Turn off the OontZ Angle 3 PLUS speaker. Go to the Bluetooth device list on your iPhone, iPad or iPod and check if the OontZ Angle 3 PLUS is listed. If it listed press the icon next to the OontZ Angle 3 PLUS and then forget this device, twice. Restart your iPhone, iPad or iPod. Next reset the OontZ Angle 3 PLUS, following the instructions on page 20. After you have reset your speaker, try to pair and connect again from your iPhone, iPad or iPod. Please see pairing and connecting instructions on page 9.

-- For Smartphones and Tablets

- Turn off the OontZ Angle 3 PLUS speaker, go to the Bluetooth device list on your Smartphone or Tablet and check if the OontZ Angle 3 PLUS is listed. If it listed press the icon next to the OontZ Angle 3 PLUS and then press Unpair this device. With the OontZ Angle 3 PLUS unpaired or if it was not listed, restart your Smartphone or Tablet. Next reset the OontZ Angle 3 PLUS, following the instructions on page 20. After you have reset your speaker, try to pair and connect again from your Smartphone or Tablet. Please see pairing and connecting instructions on page 9.

-- For Apple Mac

- Turn off the OontZ Angle 3 PLUS speaker. Please go to the Bluetooth device list and if the OontZ Angle 3 PLUS is listed please remove it. With the OontZ Angle 3 PLUS removed or if was not listed, restart your Apple Mac. Next reset the OontZ Angle 3 PLUS, following the instructions on page 20. After you have reset your speaker, try to pair and connect again from your Apple Mac. For pairing and connecting guide for your Apple Mac visit TheOontZ.com/Pairing

Troubleshooting

Cannot pair or connect to the OontZ Angle 3 PLUS (continued)

-- For Windows systems

- Turn off the OontZ Angle 3 PLUS speaker. Please go to the Bluetooth device list and if the OontZ Angle 3 PLUS is listed please remove it. With the OontZ Angle 3 PLUS removed or if was not listed, restart your Computer. Next reset the OontZ Angle 3 PLUS, following the instructions on page 20. After you have reset your speaker, try to pair and connect again from your Computer. For pairing and connecting guide for your Windows system go to TheOontZ.com/Pairing.
 - If your Windows system displays an error message requesting a driver, you need to update your computer's Bluetooth driver. The OontZ Angle 3 PLUS does not require a special driver itself and there is no driver for it. Go to the support site for your system manufacturer and specific model and select the Bluetooth driver. Download and install the Bluetooth driver, restart your system and try again to pair and connect to your OontZ Angle 3 PLUS speaker. For pairing and connecting guide for your Windows system visit TheOontZ.com/Pairing.
-

No audio playing from the OontZ Angle 3 PLUS when connected over Bluetooth

- Reset the OontZ Angle 3 PLUS, follow the reset instructions on page 20.
- Remove the OontZ Angle 3 PLUS from the Bluetooth device list on your audio source device, restart your source device, and then re-pair and connect to the speaker.
- Make sure the volume is up on your OontZ Angle 3 PLUS and your audio source device.
- Make sure your Bluetooth device is playing audio, and is not paused and volume is up.
- Your Bluetooth device may be out of range, move closer within 30 unobstructed feet.
- Turn your OontZ Angle 3 PLUS off and back on.
- Some apps have their own volume setting. Please check the app to make sure the volume is not on mute and the volume is up.

Troubleshooting

Poor sound quality when connected over Bluetooth

- Your Bluetooth device may be out of range, move closer within 30 unobstructed feet.
 - Remove the OontZ Angle 3 PLUS from the Bluetooth device list on your source device, restart your source device, and then re-pair and connect to the speaker.
 - Turn your OontZ Angle 3 PLUS off and back on.
 - Some devices need to have their WIFI turned off to improve audio quality over Bluetooth.
-

No audio playing from the OontZ Angle 3 Plus when connected with the 3.5mm audio cable

- Make sure the 3.5mm audio cable is fully inserted into the OontZ Angle 3 PLUS and Device. Some devices have cases that prevent a proper fit and need to be removed to connect. Make sure your device is on and playing music.
 - Increase the volume level on the OontZ Angle 3 PLUS and the device.
-

Poor sound quality when connected with the 3.5mm audio cable

- Reduce the volume level on the AUX source.
 - Remove the charging cable while playing.
-

No response when pressing any button or speaker will not turn off

- Reset the OontZ Angle 3 PLUS, follow the reset instructions on page 20.

Troubleshooting

If you're having trouble trying to connect your Amazon Echo Dot to your OontZ Angle 3 PLUS

- Make sure that the OontZ Angle 3 PLUS is not connected to any other audio source device. If the blue light is solid you will need to disconnect the currently paired audio source device (see page 8)
 - Check that the battery for your OontZ Angle 3 PLUS has a sufficient charge, plug your speaker into a charging source.
 - Disconnect any other Bluetooth devices from Amazon Echo Dot. Amazon Echo Dot can only connect to one Bluetooth device at a given time.
 - Try to reconnect the OontZ Angle 3 PLUS to Amazon Echo Dot. Set the speaker to pairing mode, and then say, "Alexa, connect my speaker" or "Alexa, pair"
-

Poor quality or skipping audio when connected to Amazon Echo Dot

- Make sure you have an adequate WiFi signal to your Amazon Echo Dot. Move your Amazon Echo Dot to a location with a stronger signal and away from sources of interference, such as microwave ovens, baby monitors, and other wireless devices.
-

Your OontZ Angle 3 PLUS battery charge becomes drained when connected to Amazon Echo Dot despite not playing audio

- Amazon Echo Dot continues to communicate to the speaker even when it is not playing audio. The Amazon Echo Dot is keeping the speaker on and ready to play. In order to conserve your speaker's battery charge, you can turn the OontZ Angle 3 PLUS off by pressing and releasing the Power button on the OontZ Angle 3 PLUS, or say "Alexa, disconnect my speaker" when you are done listening and the OontZ Angle 3 PLUS will automatically turn off after 15 minutes.

Resetting Your OontZ Angle 3 PLUS

Step 1: Remove the Micro USB charging cable and 3.5mm Audio cable, if connected

Step 2: Press and Release the Power Button

Step 3: Insert either a toothpick or straightened paper clip into the AUX IN jack until it makes contact with the micro switch. Gently push and release the switch and the speaker will reset.



Customer Support

If you have any issues with your OontZ Angle 3 PLUS, we want to assist you. Please contact us by visiting:

TheOontZ.com/support and fill out our customer support form.

Safety and Precautions

1. Follow all instructions – All operating and use instructions should be followed.
2. Do not use this speaker near water while it is plugged in for charging, due to risk of electric shock.
3. Protect the Micro USB charging cable from being pinched, particularly at the connectors.
4. Unplug the Micro USB charging cable during lightning storms.

Apple, iPhone, iPad, iPod, and Mac are registered trademarks of Apple Inc.

Amazon, Alexa, and Amazon Echo Dot are registered trademarks of Amazon.com, Inc.

Windows is a registered trademark of Microsoft Corporation

Bluetooth is a registered trademark of Bluetooth SIG, Inc.

Safety and Precautions (continued)

1. This equipment has been tested and found to comply with the limits for a Class B digital device, pursuant to part 15 of the FCC Rules. These limits are designed to provide reasonable protection against harmful interference in a residential installation. This equipment generates, uses and can radiate radio frequency energy and, if not installed and used in accordance with the instructions, may cause harmful interference to radio communications. However, there is no guarantee that interference will not occur in a particular installation. If this equipment does cause harmful interference to radio or television reception, which can be determined by turning the equipment off and on, the user is encouraged to try to correct the interference by one or more of the following measures:

- Reorient or relocate the receiving antenna.
- Increase the separation between the equipment and receiver.
- Connect the equipment into an outlet on a circuit different from that to which the receiver is connected.
- Consult the dealer or an experienced radio/TV technician for help.

2. This device complies with Part 15 of the FCC Rules. Operation is subject to the following two conditions:

(1) This device may not cause harmful interference, and (2) this device must accept any interference received, including interference that may cause undesired operation.

3. Any changes to this device not expressly approved by SoundWorks, INC may void the user's authority to operate this device.