



OontZ

Angle 3

Ultra-Portable Bluetooth Speaker
Quick Start Guide

Designed and Engineered By
CAMBRIDGE SOUNDWORKS.

Please visit TheOontZ.com

Table of Contents

	Pages
In the Package	1
Buttons and Connectors	2
Charging the Battery	3 - 4
Turning On and Off	5
Pairing & Connecting	6
Pairing & Connecting – From Your Mobile Device	7
Pairing & Connecting – From Your Apple Mac or Windows Computer	7
Playing From Your Laptop, Computer and Non-Bluetooth Devices Using the 3.5mm Audio Cable	8
IPX5 Water Resistance	9
Wireless Hands Free Personal Speakerphone	10
Troubleshooting & Customer Support	11 - 13
Resetting Your OontZ Angle 3	14
Safety and Precautions	15

In the Package

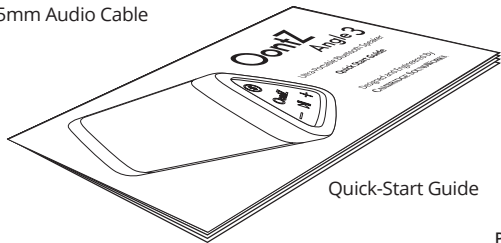
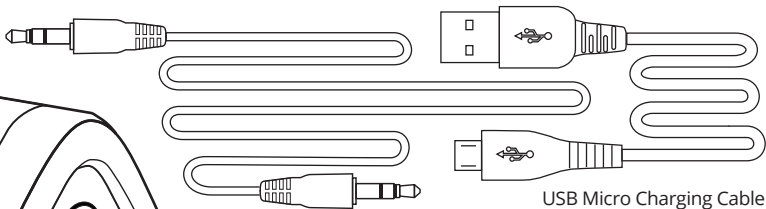
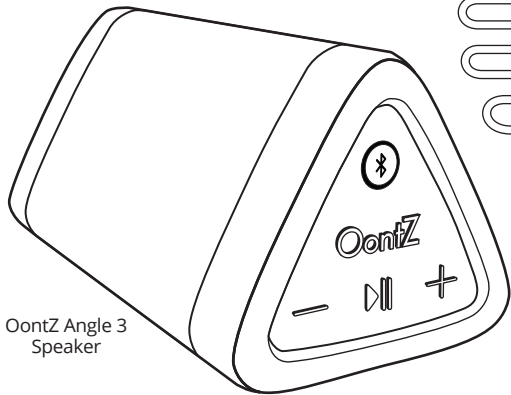

Buttons and Connectors

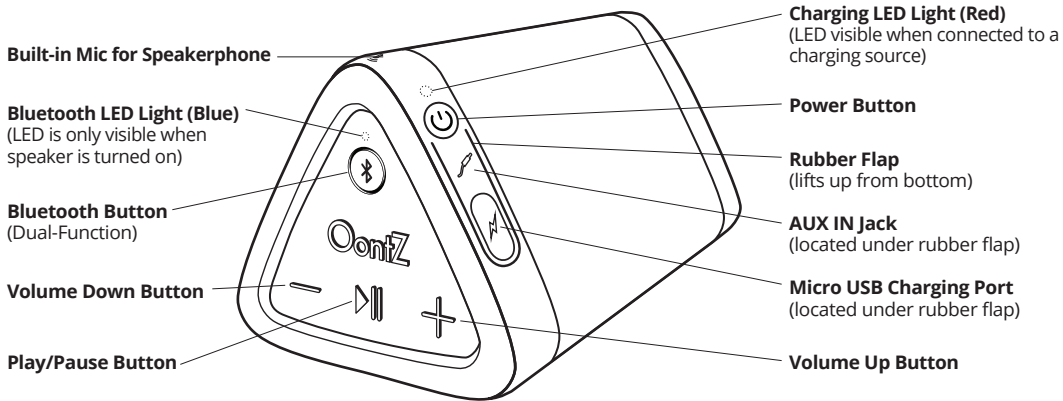

Charging the Battery

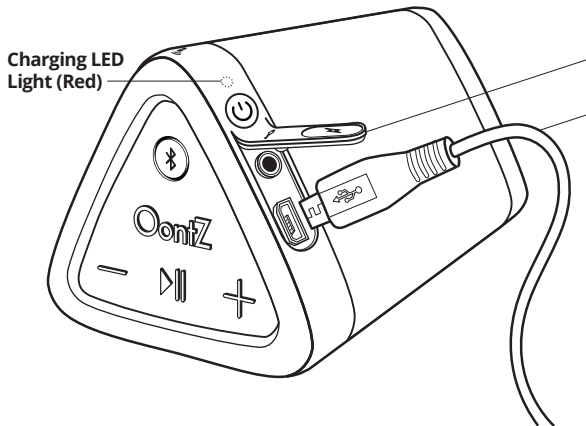

The lithium ion rechargeable battery will have a partial charge and be ready to play. For maximum playtime, fully charge the battery. You can play while charging.

To charge the battery:

Step 1: Lift up the rubber flap from the bottom to access the Micro USB Charging Port.

Step 2: Insert the smaller end of the Micro USB Cable into the Micro USB Charging Port as shown.

Step 3: Insert the other end of the Micro USB cable into either a USB wall charger for a Smartphone or iPhone, or a USB port on your laptop to charge the battery.

Charging LED Light (Red)

(LED visible when connected to a charging source)

Slowly flashing Red when charging
Solid Red when fully charged

Note: Close the rubber flap when not charging. The rubber flap needs to be closed to keep the speaker water resistant

Charging the Battery (continued)

Music Play Time

Up to 7 hours on a full charge, with volume at 60%. Louder volumes will reduce the battery play time.

Play while charging

You can play the OontZ Angle 3 while it is charging.

Power Saving Feature

- When playing from battery power the OontZ Angle 3 will turn off after 15 minutes of not playing audio to conserve the battery charge.
- When plugged in to a charging source the OontZ Angle 3 will remain on until you turn the power off. You can continue to keep the speaker plugged in to a charging source even when it is fully charged.

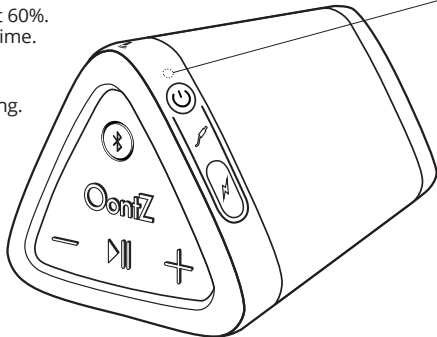

Low Charge Remaining Indicator

When the battery charge is down to about 15% the Charging LED Light (Red) will begin flashing Red and will remain flashing until the speaker is turned off. The volume will decrease to preserve the remaining battery charge.

Charging Time

It will take about 5 to 6 hours to fully charge a low battery.

Turning On and Off

Bluetooth LED Light (Blue)

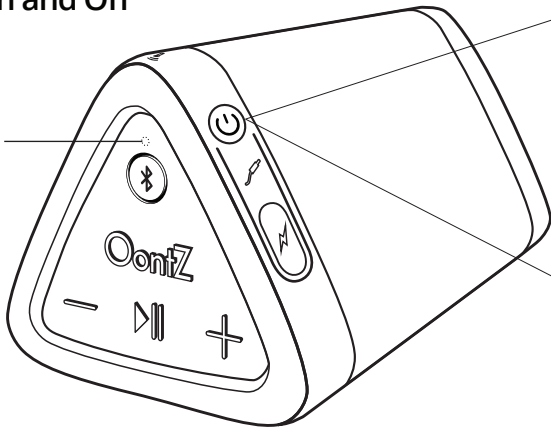

Turn ON

Press and Release the Power Button

Bluetooth LED Light (Blue)

Blue light will turn on

Flashing Blue indicates speaker is in pairing mode

Solid Blue indicates speaker is connected to a source device and ready to play

Turn OFF

Press and Hold Down the Power Button for 3 Seconds

Bluetooth LED Light

Blue light will turn off

Pairing & Connecting

- Make sure your OontZ Angle 3 battery has a sufficient charge
- Your source device needs to be within 30 unobstructed feet of the OontZ Angle 3

Turn ON your OontZ Angle 3

The Bluetooth LED Light (Blue) will turn on.

If the blue light is flashing the OontZ Angle 3 is ready to pair and connect.

If the blue light is solid the OontZ Angle 3 has automatically reconnected to the last source device the speaker was connected to and is ready to play. *Note: The OontZ Angle 3 will automatically try to connect to the last source device it was connected to each time it is turned on and that source device is within range.*

The OontZ Angle 3 can be connected to one source device at a time.

To pair and connect to a different source device, you need to first disconnect the currently paired source device. To disconnect it, press and hold down the **Bluetooth button** for 3 seconds. The blue light will begin **flashing** and the OontZ Angle 3 is ready to pair and connect.

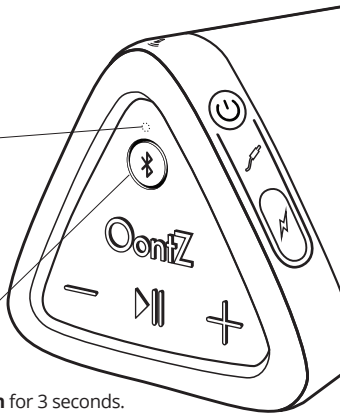

Pairing & Connecting -- From Your Mobile Device

To pair and connect from an iPhone, iPad, or iPod:

- Go to Settings > Bluetooth, check Bluetooth is on
- Select 'OontZ Angle' when it appears under OTHER DEVICES
- The speaker will connect in a few seconds
- The **Bluetooth LED Light (Blue)** will be solid blue
- You can now play your audio wirelessly to your OontZ Angle 3

To pair and connect from a Smartphone or Tablet:

- Go to Settings > Bluetooth, check Bluetooth is on
- Scan or Search and select 'OontZ Angle' when it appears under AVAILABLE DEVICES
- The speaker will connect in a few seconds
- The **Bluetooth LED Light (Blue)** will be solid blue
- You can now play your audio wirelessly to your OontZ Angle 3

Note: Your Smartphone or Tablet instructions may vary, please check your mobile device's manual for specific pairing instructions

Pairing & Connecting -- From Your Apple Mac or Windows Computer

For the pairing and connecting guide for your Apple Mac or Windows computer, please visit: TheOontZ.com/pairing

Some older Windows computers and operating systems may have difficulty pairing and connecting over Bluetooth. If this occurs it is recommended to connect using the 3.5mm audio cable. Please go to page 8: 'Playing from Your Laptop, Computer and Non-Bluetooth Devices Using the 3.5mm Audio Cable'.

Playing From Your Laptop, Computer and Non-Bluetooth Devices Using the 3.5mm Audio Cable

- Make sure your OontZ Angle 3 battery has a sufficient charge

Plug one end of the included 3.5mm audio cable into the **AUX IN Jack** on the back of your speaker.

Plug the other end of the 3.5mm audio cable into the headphone jack on your source device.

You are now ready to play.

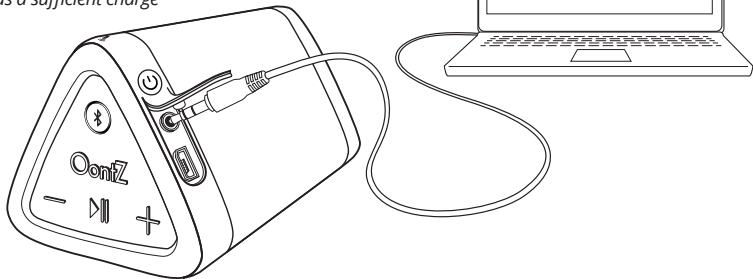

- Note: The Bluetooth on the OontZ Angle 3 is disabled when the 3.5mm audio cable is connected to the speaker. You need to remove the 3.5mm audio cable from the speaker in order to connect to a Bluetooth source device.

- Note: Close the rubber flap when not using the 3.5mm audio cable. The rubber flap needs to be closed to keep the speaker water resistant.

IPX5 Water Resistance

No more worries about the rain or getting splashed.

Listen to music in the shower.

Perfect for taking to the beach or by the pool.

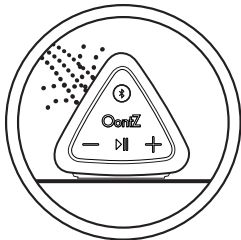

**Gentle Water Spray
or Splash is okay**



**DO NOT allow speaker
to sit in water**



**DO NOT allow speaker
to submerge fully or
partially in water**

IPX5 rating - The OontZ Angle 3 can resist gentle water spray & splash but cannot be partially or fully submerged or left in a wet environment for an extended period of time, any of which could cause unrepairable damage to the speaker.

- Note: The rubber flap needs to be closed to keep the speaker water resistant. When charging or using the 3.5mm audio cable, please keep the speaker away from water as it can be damaged by water entering the connectors.

Wireless Hands Free Personal Speakerphone

**Bluetooth Button
(Dual Function)**

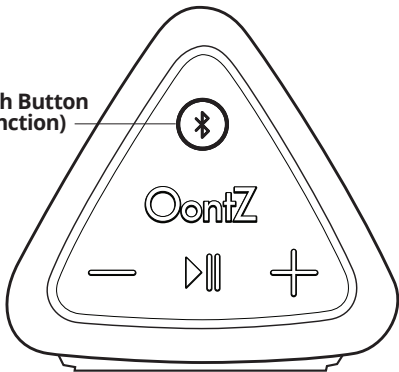

To answer an Incoming Call / To End a Call

Press and Release the Bluetooth Button

To Reject an Incoming Call

Press and Hold Down the Bluetooth Button for 3 Seconds

The Wireless Hands Free Personal Speakerphone feature works over Bluetooth with Smartphones and iPhones for cell phone calls only.

Please keep the speaker close in front of you so you may be heard clearly by the listener.

You can use your Smartphone or iPhone to switch between using Hands Free Speakerphone and your phone.

Troubleshooting & Customer Support

For assistance with questions or any issue with your OontZ Angle 3 that is not answered in the troubleshooting tips below, please contact us by visiting: **TheOontZ.com/support** and filling out our customer service form.

OontZ Angle 3 will not turn on

- The battery may have become fully drained. Charge the OontZ Angle 3 using a USB wall charger from a Smartphone/iPhone or tablet for at least 15 minutes, then press the power button to turn the speaker on. Then continue charging the battery.
 - Reset the OontZ Angle 3, follow the reset instructions on page 14.
-

Cannot pair or connect to the OontZ Angle 3

- Check that your OontZ Angle 3 has a sufficient battery charge, the speaker may not connect when the battery has a low charge. Connect the speaker to a charging source and try again to pair and connect.
- Your source device may be out of range. Move it closer to within 30 unobstructed feet of your speaker.
- Check the Bluetooth LED light (Blue) to make sure it is flashing. If it is solid blue the OontZ Angle 3 is already connected to another source device. The OontZ Angle 3 can be connected to one source device at a time. You need to disconnect the connected source device then you can connect to the next source device. Please see instructions on page 6.
- Your source device may have a temporary Bluetooth connection issue please try the following steps which can resolve this: (continued next page)

Cannot pair or connect to the OontZ Angle 3 (continued)

For iPhone, iPad, iPod

- Turn off the OontZ Angle 3 speaker, go to the Bluetooth device list on your iPhone, iPad or iPod and check if the OontZ Angle is listed. If it listed press the icon next to the OontZ Angle and then forget this device, twice.
With the OontZ Angle removed from the list or if it was not listed, do a hard reset on your iPhone, iPad or iPod by pressing and holding down the Home and sleep buttons at the same time for about 10 seconds until the Apple icon appears and it restarts. When it restarts turn on the OontZ Angle 3 and then try again to pair and connect. Please see instructions on page 7.

For Smartphones and Tablets

- Turn off the OontZ Angle 3 speaker, go to the Bluetooth device list on your Smartphone or Tablet and check if the OontZ Angle is listed. If it listed press the icon next to the OontZ Angle and then press Unpair this device. With the OontZ Angle unpaired or if it was not listed, do a hard restart on your Smartphone or Tablet. When it restarts turn on the OontZ Angle 3 and then try again to pair and connect. Please see instructions on page 7.

For Apple Mac

- Please go to the Bluetooth device list and if the OontZ Angle is listed please remove it. With the OontZ Angle removed or if was not listed, restart your Apple Mac and then try again to pair and connect. For pairing and connecting Guide for your Apple Mac visit TheOontZ.com/Pairing

For Windows systems

- Please go to the Bluetooth device list and if the OontZ Angle is listed please remove it. With the OontZ Angle removed or if was not listed, restart your Computer and then try again to pair and connect. – For pairing and connecting Guide for your Windows system go to TheOontZ.com/Pairing
- If your Windows system displays an error message requesting a driver. You need to update your computer's Bluetooth driver. The OontZ Angle 3 does not require a special driver itself and there is no driver for it. Go to the support site for your system manufacturer and specific model and select the Bluetooth driver. Download and install the Bluetooth driver, restart your system and try again to pair and connect to your OontZ Angle 3 speaker. For pairing and connecting Guide for your Windows system visit TheOontZ.com/Pairing

No audio playing from the OontZ Angle 3 when connected over Bluetooth

- Reset the OontZ Angle 3, follow the reset instructions on page 14.
 - Remove the OontZ Angle 3 from the Bluetooth device list on your source device, restart your source device, and then re-pair and connect to the speaker.
 - Make sure the volume is up on your OontZ Angle 3 and your source device.
 - Make sure your Bluetooth device is playing audio, and is not paused and volume is up.
 - Your Bluetooth device may be out of range, move closer within 30 unobstructed feet.
 - Turn your OontZ Angle 3 off and back on.
 - Some apps have their own volume setting. Please check the app to make sure the volume is not on mute and the volume is up.
-

Poor sound quality when connected over Bluetooth

- Your Bluetooth device may be out of range, move closer within 30 unobstructed feet.
 - Remove the OontZ Angle 3 from the Bluetooth device list on your source device, restart your source device, and then re-pair and connect to the speaker.
 - Turn your OontZ Angle 3 off and back on.
 - Some devices need to have their WIFI turned off to improve audio quality over Bluetooth.
-

No audio playing from the OontZ Angle 3 when connected with the 3.5mm audio cable

- Make sure the 3.5mm audio cable is fully inserted into the OontZ Angle 3 and Device. Some devices have cases that prevent a proper fit and need to be removed to connect. Make sure your device is on and playing and music
 - Increase the volume level on the OontZ Angle 3 and the device.
-

Poor sound quality when connected with the 3.5mm audio cable

- Reduce the volume level on the AUX source.
 - Remove the charging cable while playing.
-

No response when pressing any button or speaker will not turn off

- Reset the OontZ Angle 3, follow the reset instructions on page 14.

Resetting Your OontZ Angle 3

To reset the OontZ Angle 3 insert either a toothpick or straightened paper clip into the AUX IN jack until it makes contact with the micro switch. Gently push and release the switch and the speaker will reset.

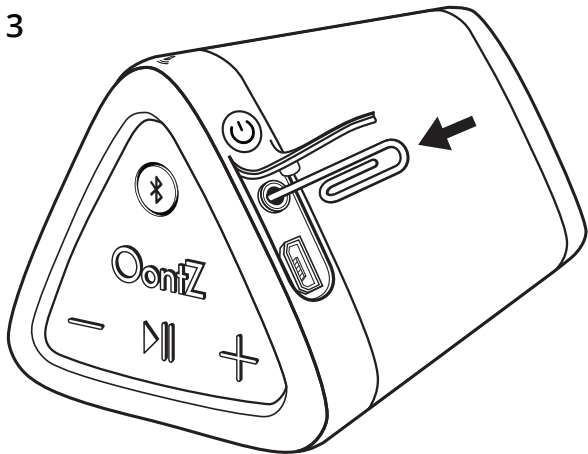

Safety and Precautions

1. Follow all instructions – All operating and use instructions should be followed.
2. Do not use this apparatus near water while plugged in for charging, due to risk of electric shock.
3. Protect the Micro USB charging cable from pinched particularly at the connectors.
4. Unplug the Micro USB charging cable during lightning storms or when unused for long periods of time.

OontZ Angle 3 Carry Case

Sold separately

- Lightweight neoprene rubber with reinforced zipper
- Includes a durable aluminum carabiner for easily attaching to backpacks, luggage, laptop bags, coolers, camera bags, purses, belts, and other clippable items

Available at TheOontZ.com:
TheOontZ.com/angle3-carry-case



FCC Warning

This device complies with Part 15 of the FCC Rules. Operation is subject to the following two conditions:

(1) This device may not cause harmful interference, and (2) this device must accept any interference received, including interference that may cause undesired operation.

NOTE 1: This equipment has been tested and found to comply with the limits for a Class B digital device, pursuant to part 15 of the FCC Rules. These limits are designed to provide reasonable protection against harmful interference in a residential installation. This equipment generates, uses and can radiate radio frequency energy and, if not installed and used in accordance with the instructions, may cause harmful interference to radio communications. However, there is no guarantee that interference will not occur in a particular installation. If this equipment does cause harmful interference to radio or television reception, which can be determined by turning the equipment off and on, the user is encouraged to try to correct the interference by one or more of the following measures:

- Reorient or relocate the receiving antenna.
- Increase the separation between the equipment and receiver.
- Connect the equipment into an outlet on a circuit different from that to which the receiver is connected.
- Consult the dealer or an experienced radio/TV technician for help.

NOTE 2: Any changes or modifications to this unit not expressly approved by the party responsible for compliance could void the user's authority to operate the equipment.