



RF Exposure Evaluation

Product Name:	Multifunctional Desk Lamp
Model No.:	F16
Transmitting mode	Keep the EUT in continuously wireless charging mode
Power supply:	Input USB-C: 5V=3A, 9V=3A, 12V=2.5A USB-C Output: 5V-2A USB-A Output: 5V-2A Wireless Output:5W, 7.5W, 10W, 15W(Max)

Test Modes:		
TM1	Adapter+Wireless charging 15W	Record
TM2	Adapter+Wireless charging 10W	Record
TM4	Adapter+Wireless charging 7.5W	Record
TM4	Adapter+Wireless charging 5W	Record

Note: All modes have been tested and only the worst mode Adapter+Wireless charging 15W data is represented in the report.

1 Test Instruments list

Software name	Manufacturer	Model	Version
EHP200-TS	Narda	EHP-200A	Rel 1.95

Item	Equipment No.	Equipment name	Manufacturer	Model	Serial No.	Calibration date	Due date
1	HB-E073	Electric and Magnetic Field Analyzer	Narda	EHP-200 A	180ZX1101 3	2024-05-21	2025-05-20

Note: the calibration interval of the above test instruments is 12 months and the calibrations are traceable to international system unit (SI).

2 Test Setup

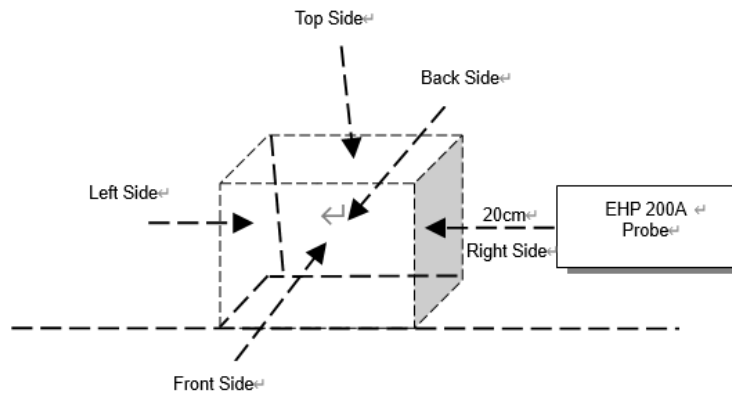



3 Test Procedure

- 1) The RF exposure test was performed in anechoic chamber.
- 2) E and H-field measurements should be made with the center of the probe at a distance of 20m surrounding the device and 20 cm above the top surface of the primary/client pair.
These measurements should be repeated for three different client battery levels, 1%, 50%, and 99%.
- 3) The highest emission level was recorded and compared with limit as soon as measurement of each points were completed.
- 4) The EUT was measured according to the dictates of KDB 680106 D01 v04.

Limits

The criteria listed in the following table shall be used to evaluate the environment impact of human exposure to radio frequency (RF) radiation as specified in 1.1307(b)

Limits for Maximum Permissible Exposure (MPE)

Frequency range (MHz)	Electric field strength (V/m)	Magnetic field strength (A/m)	Power density (mW/cm ²)	Averaging time (minutes)
(A) Limits for Occupational/Controlled Exposures				
0.3-3.0	614	1.63	*(100)	6
3.0-30	1842/f	4.89/f	*(900/f ²)	6
30-300	61.4	0.163	1.0	6
300-1500	/	/	f/300	6
1500-100,000	/	/	5	6
(B) Limits for General Population/Uncontrolled Exposure				
0.3-1.34	614	1.63	*(100)	30
1.34-30	824/f	2.19/f	*(180/f ²)	30
30-300	27.5	0.073	0.2	30
300-1500	/	/	f/1500	30
1500-100,000	/	/	1.0	30
F=frequency in MHz *=Plane-wave equivalent power density RF exposure compliance will need to be determined with respect to 1.1307(c) and (d) of the FCC rules. The emissions should be within the limits at 300kHz in Table 1 of 1.1310(use the 300kHz limits for 150kHz:614V/m,1.63A/m).				

4 Measuring Standard

KDB 680106 D01 Wireless Power Transfer v04r01



5 Requirements

According to the item 5 of KDB 680106 D01 Wireless Power Transfer v04r01:

Inductive wireless power transfer applications that meet all of the following requirements are excluded from submitting an RF exposure evaluation.

- (1) The power transfer frequency is below 1MHz.

Yes, the device operate in the frequency range from 110.5KHz to 250KHz.

- (2) The output power from each transmitting element (eg., coil) is less than or equal to 15 watts.

Yes, the maximum output power of the primary coil is 15W.

- (3) A client device providing the maximum permitted load is placed in physical contact with the transmitter (i.e., the surfaces of the transmitter and client device enclosures need to be in physical contact)

Yes, the surfaces of the transmitter and client device enclosures need to be in physical contact.

- (4) Only § 2.1091-Mobile exposure conditions apply (i.e., this provision does not cover § 2.1093-Portable exposure conditions).

Yes, this device is a mobile device.

- (5) The E-field and H-field strengths, at and beyond 20 cm surrounding the device surface, are demonstrated to be less than 50% of the applicable MPE limit, per KDB 447498, Table 1. These measurements shall be taken along the principal axes of the device, with one axis oriented along the direction of the estimated maximum field strength, and for three points per axis or until a 1/d (inverse distance from the emitter structure) field strength decay is observed. Symmetry considerations may be used for test reduction purposes. The device shall be operated in documented worst-case compliance scenarios (i.e., the ones that lead to the maximum field components), and while all the radiating structures (e.g., coils or antennas) that by design can simultaneously transmit are energized at their nominal maximum power.

The EUT field strength levels are less 50% x MPE limit.

- (6) For systems with more than one radiating structure, the conditions specified in (5) must be met when the system is fully loaded (i.e., clients absorbing maximum power available), and with all the radiating structures operating at maximum power at the same time, as per design conditions. If the design allows one or more radiating structures to be powered at a higher level while other radiating structures are not powered, then those cases must be tested as well. For instance, a device may use three RF coils powered at 5 W, or one coil powered at 15 W: in this case, both scenarios shall be tested.

This device has only one wireless charging coil.

6 Test Result

Maximum permissible Exposure				
Battery levels	Test sides	Test distance(cm)	E -field(V/m)	H-field(A/m)
<1%	Top	20	2.471	0.327
<1%	Left	20	4.255	0.226
<1%	Right	20	6.344	0.475
<1%	Front	20	3.669	0.176
<1%	Back	20	1.721	0.187
Limit			614	1.63
50% Margin Limit			307	0.815

Maximum permissible Exposure				
Battery levels	Test sides	Test distance(cm)	E -field(V/m)	H-field(A/m)
<50%	Top	20	2.151	0.164
<50%	Left	20	4.372	0.235
<50%	Right	20	6.193	0.237
<50%	Front	20	3.898	0.199
<50%	Back	20	1.377	0.177
Limit			614	1.63
50% Margin Limit			307	0.815

Maximum permissible Exposure				
Battery levels	Test sides	Test distance(cm)	E -field(V/m)	H-field(A/m)
<99%	Top	20	2.747	0.341
<99%	Left	20	4.723	0.188
<99%	Right	20	6.666	0.377
<99%	Front	20	3.544	0.286
<99%	Back	20	2.351	0.214
Limit			614	1.63
50% Margin Limit			307	0.815

7 Test Setup Photo

