

# 承认书

SPECIFICATION FOR APPROVAL

客户名称 (CUSTOMER): 秉鑫科技有限公司

客户料号 (CUSTOMER P/N): F16

品名 (DESCRIPTION): 无线充线圈 Wireless charging coil DATE: 2024/07/04

规格 (SPECIFICATION): G50+0.5mmEVA 60mmmm REV.NO.: A0

深圳市鸿日昇威科技有限公司

HRSW ELECTRONICS CO.,LTD

ADD: 深圳市龙华新区观澜环观中路48号1栋2楼

2nd Floor, Building 1, No. 48 Huanguan Middle Road, Guanlan, Longhua New  
District, Shenzhen

TEL: +86-15112254520 FAX: +86-0755-28015170

page: 1/2



# SPECIFICATION FOR APPROVAL

## 1.MECHANICAL DIMENSION (UNIT:mm)

## 2. SCHEMATICS:

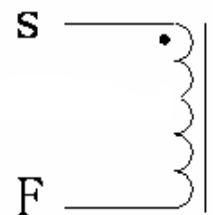
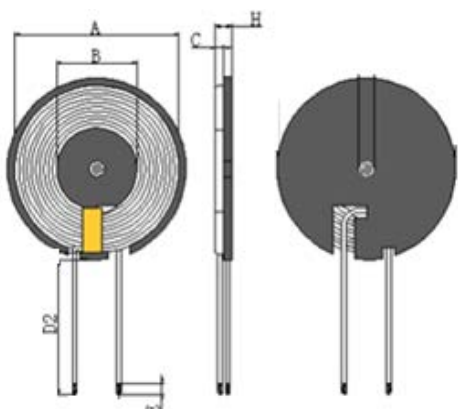

A	B	C	D2	E	H				I
50±0.5	20±1	0.8±0.5	60±3	3.5±2	2.2MAX				

## 3.WINDING:

ST EP	START-FINISH	WIRE TYPE	TURNS	TAPE	REMARK
N1	S-F	Hot air wire Ø0.08*24mm 1UEW	10TS (Ref)		

## 4. ELECTRICAL SPECIFICATION:

ITEM	L	DCR	L	Q值	HI-POT
TEST	Coil and diskette	S-F	Individual coil		
CON	100KHz, 0.25V	AT 25°C	100KHz, 0.25V		
SPEC	6.5uH±10%	70mΩ Max	3.8uH±15%		

## 5.BILF OF MATERIAL:

NO.	ITEM	MATERIAL SPECIFICATION	MANUFACTURER	SGS NO.
1	0.08*24	Hot wind 0.08*24*2P	NANJINGJINNINGCO,LTD	
2	Lead-free tin strip	Lead-free tin strip	QIAODO	
3	Magnetic sheet	Ø50*0.5 Manganese zinc hard disk with L slot	TAIYI CO.,LTD	
4	glue	Yellow gum 9999	LIANCHENG CO.,LTD	
5	High-temperature adhesive paper	8mmWide high temperature adhesive paper	CUDAK CO.,LTD	
6	Rubber backing	48.5*0.5EVA	CUDAK CO.,LTD	

HRSW ELECTRONICS CO.,LTD		PART NO		
		TITLE	F16 coil	
DRAWN BY		CHECKED BY		APPROVED BY
何伟华 Weihua He		韦立红 Lihong Wei		韦立红 Lihong Wei