



TEST REPORT

REPORT NUMBER: B15W00164-FCC-RF

ON

Type of Equipment: Wireless Modules
Model Name: WP8548
Manufacturer: Sierra Wireless Inc.

ACCORDING TO

FCC CFR Part 2, FREQUENCY ALLOCATIONS AND RADIO TREATY MATTERS;
GENERAL RULES AND REGULATIONS; e-CFR, Mar 17, 2015

PART 22, PUBLIC MOBILE SERVICES , e-CFR, Mar 17, 2015

PART 24, PERSONAL COMMUNICATIONS SERVICES, e-CFR, Mar 17, 2015

RSS-Gen — General Requirements for Compliance of Radio Apparatus., November
13, 2014

RSS-132 — Cellular Telephone Systems Operating in the Bands 824-849 MHz and
869-894 MHz, Issue 3, January 2013

RSS-133 — 2GHz Personal Communications Services, Issue 6, January 2013

China Telecommunication Technology Labs.

Month date, year

Feb, 15, 2016

Signature



He Guili
Director

FCC ID: N7NWP8548
IC: 2417C-WP8548
Report Date: 2016-2-15

Test Firm Name: Chongqing Institute of Telecommunications
FCC Registration Number: 428018
IC Registration Number: 11590A

Statement

The measurements shown in this report were made in accordance with the procedures described on test pages. All reported tests were carried out on a sample equipment to demonstrate limited compliance with FCC CFR 47 Parts 2, 22, 24 and RSS-Gen, 132, 133. The sample tested was found to comply with the requirements defined in the applied rules.

CONTENTS

1 GENERAL INFORMATION	4
1.1 NOTES	4
1.2 TESTERS	5
1.3 TESTING LABORATORY INFORMATION	6
1.4 DETAILS OF APPLICANT OR MANUFACTURER	7
2 TEST ITEM	8
2.1 GENERAL INFORMATION	8
2.2 OUTLINE OF EUT	8
2.3 MODIFICATIONS INCORPORATED IN EUT	8
2.4 EQUIPMENT CONFIGURATION	8
2.5 OTHER INFORMATION	8
3 SUMMARY OF TEST RESULTS	9
4 TEST RESULTS	11
4.1 RADIATED SPURIOUS EMISSION	11
4.2 OCCUPIED BANDWIDTH	17
4.3 FREQUENCY STABILITY OVER TEMPERATURE VARIATION	29
4.4 FREQUENCY STABILITY OVER VOLTAGE VARIATION	32
4.5 CONDUCTED RF POWER OUTPUT	34
4.6 CONDUCTED SPURIOUS EMISSION	38
4.7 BAND EDGE	63
ANNEX A EXTERNAL PHOTOS	71
ANNEX B INTERNAL PHOTOS	71
ANNEX C DEVIATIONS FROM PRESCRIBED TEST METHODS	71

1 General Information

1.1 Notes

All reported tests were carried out on a sample equipment to demonstrate limited compliance with FCC CFR 47 Parts 2, 22, 24 and RSS-Gen, 132, 133.

The test results of this test report relate exclusively to the item(s) tested as specified in section 2.

The following deviation from, additions to, or exclusions from the test specifications have been made. See Annex C.

China Telecommunication Technology Labs authorizes the applicant or manufacturer (see section 1.4) to reproduce this report provided, and the test report may only be reproduced or published in full. Reproduction or publication of extracts from the report requires the prior written approval of China Telecommunication Technology Labs. Mr. He Guili.

Any use which a third party makes of this report, or any reliance on or decisions to be made based on it, are the responsibility of such third parties. Chongqing Institute of Telecommunications accepts no responsibility for damages, if any, suffered by any third party as a result of decisions made or actions based on this report.

1.2 Testers

Name: Chen Wen
Position: Engineer
Department: Department of RF test
Date: 2015-12-21 to 2016-2-15
Signature: 

Editor of this test report:

Name: Zhou Jin
Position: Engineer
Department: Department of RF test
Date: 2016-2-15
Signature: 

Technical responsibility for area of testing:

Name: Zhang Yan
Position: Manager
Department: Director of the laboratory
Date: 2016-2-15
Signature: 

1.3 Testing Laboratory information

1.3.1 Location

Name: Chongqing Institute of Telecommunications
Address: No. 8, Yuma Road, Chayuan New City, Nan'an District,
Chongqing
P. R. CHINA, 401336
Tel: +86-23-88069965
Fax: +86-23-88608777
Email: songweiwei@chinattl.com

1.3.2 Details of accreditation status

Accredited by: China National Accreditation Service for Conformity
Assessment (CNAS)
Registration number: CNAS Registration No. CNAS L0570
Standard: ISO/IEC 17025:2005

1.3.3 Test location, where different from section 1.3.1

Name: -----
Street: -----
City: -----
Country: -----
Telephone: -----
Fax: -----
Postcode: -----

1.4 Details of applicant or manufacturer

1.4.1 Applicant

Name: Sierra Wireless Inc.
Address: 13811, Wireless Way, Richmond, British Columbia
Country: Canada
Telephone: +1 604 232 1440
Fax: +1 604 231 1109
Contact: Ying Wang
Telephone: +1 604 232 1440
Email: ywang@sierrawireless.com

1.4.2 Manufacturer (if different from applicant in section 1.4.1)

Name: --
Address: --
City: --
Country: --

2 Test Item

2.1 General Information

Manufacturer: Sierra Wireless Inc.
 Type of Equipment: Wireless Modules
 Model Name: WP8548
 Serial Number: S1/3: 359377060005195;
 S2/3: 359377060005203;
 S3/3: 359377060005716
 Production Status: Product
 Receipt date of test item: 2015-12-21

2.2 Outline of EUT

The EUT, WP8548 is a model supporting EDGE/GPRS/GSM 850/1900 bands, UMTS/HSDPA/HSUPA FDDII/V bands.

2.3 Modifications Incorporated in EUT

The EUT has not been modified from what is described by the brand name and unique type identification stated above.

2.4 Equipment Configuration

Equipment configuration list:

Item	Generic Description	Manufacturer	Type	Serial No.	Remarks
A	Modem	Sierra Wireless Inc.	WP8548	S1/3: 359377060005195; S2/3: 359377060005203; S3/3: 359377060005716	None
B	Adaptor	None	None	--	None

2.5 Other Information

--

3 Summary of Test Results

A brief summary of the tests carried out is shown as following.

GSM/GPRS/EGPRS mode:			
FCC Rules	IC Standards	Name of Test	Result
2.1051, 24.238, 2.1053,22.917	RSS-132 4.5 RSS-133 6.5	Radiated Spurious Emission	Pass
2.1049,22.917(b), 24.238(b)	RSS-Gen 6.6	Occupied Bandwidth	*Note 1
2.1055,22.355, 24.235	RSS-132 4.3 RSS-133 6.3	Frequency Stability over Temperature Variation	Pass
2.1055,22.355, 24.235	RSS-132 4.3 RSS-133 6.3	Frequency Stability over Voltage Variation	Pass
2.1046,22.913(a),24.232(c)	RSS-132 4.4 RSS-133 6.4	Conducted RF Power Output	Pass
2.1051,22.917, 24.238	RSS-132 4.5 RSS-133 6.5	Conducted spurious emissions	Pass
2.1051,24.238, 2.1053, 22.917	RSS-132 4.5 RSS-133 6.5	Band Edge	Pass
Note 1: No applicable performance criteria.			

WCDMA/HSUPA/HSDPA mode:			
FCC Rules	IC Standards	Name of Test	Result
2.1051, 24.238, 2.1053,22.917	RSS-132 4.5 RSS-133 6.5	Radiated Spurious Emission	Pass
2.1049,22.917(b , 24.238(b)	RSS-Gen 6.6	Occupied Bandwidth	*Note 2
2.1055,22.355, 24.235	RSS-132 4.3 RSS-133 6.3	Frequency Stability over Temperature Variation	Pass
2.1055,22.355, 24.235	RSS-132 4.3 RSS-133 6.3	Frequency Stability over Voltage Variation	Pass
2.1046,22.913(a ,24.232(c)	RSS-132 4.4 RSS-133 6.4	Conducted RF Power Output	Pass
2.1051,22.917, 24.238	RSS-132 4.5 RSS-133 6.5	Conducted spurious emissions	Pass
2.1051,24.238, 2.1053, 22.917	RSS-132 4.5 RSS-133 6.5	Band Edge	Pass
Note 2: No applicable performance criteria.			

Test equipment Used:						
Asset Number	Description	Manufacturer	Model Number	Serial Number	Cal Due	State
CWY5110	EMI Test Receiver	R/S	ESU26	100367	2016-03-05	Normal
CWY5119	Ultra Broadband Antenna	R/S	VULB 9163	9163-544	2016-12-13	Normal
CWY5127	Double-Ridged Horn Antenna	R/S	HF907	100356	2016-12-13	Normal
CNY5153	Fully-Anechoic Chamber	ETS	11.8m×6.5m ×6.3m	--	2017-08-19	Normal
CNY0676	Radio Communications Analyzer	R/S	CMW500	128181	2016-03-05	Normal
CWY5125	Signal Generator	R/S	SMF100A	102222	2016-03-05	Normal
CWY5007	spectrum analyzer	R/S	FSQ 26	201137/026	2016-03-05	Normal
CXY5323	Radio Communications Analyzer	R/S	CMU200	112012	2016-03-05	Normal

4 Test Results

4.1 Radiated Spurious Emission

Specifications:	FCC Part 2.1051, 22.917, 2.1053, 22.917, RSS-132 4.5, RSS-133 6.5
Date of Tests	2015-12-22-2015-12-23
DUT Serial Number	S1/3: 359377060005195
Test conditions:	Ambient Temperature: 15°C-35°C Relative Humidity: 30%-60% Air pressure: 86-106kPa
Operation Mode	TX on, channel 190 and 661 for GSM/GPRS/EGPRS mode, channel 9400, and 4182 for WCDMA/HSUPA/HSDPA mode.
Test Results:	Pass

Limit Level Construction:

Part 22:

According to Part 22.917(a), i.e., Out of band emissions, the power of any emission outside of the authorized operating frequency ranges must be attenuated below the transmitting power (P) by a factor of at least $43 + 10 \log(P)$ dB, so the limit level is:

$$P(\text{dBm}) - (43 + 10 \log(P)) \text{ dB} = -13\text{dBm}$$

Part 24:

According to Part 24.238 (a), i.e., Out of band emissions, the power of any emission outside of the authorized operating frequency ranges must be attenuated below the transmitting power (P) by a factor of at least $43 + 10 \log(P)$ dB, so the limit level is:

$$P(\text{dBm}) - (43 + 10 \log(P)) \text{ dB} = -13\text{dBm}$$

Test Setup:

The EUT was placed in an anechoic chamber. The Wireless Communications Test Set was used to set the TX channel and power level and modulate the TX signal with different bit patterns.

Test Method:

The measurement method is substitution method accordance with section 2.2.12 of ANSI/TIA-603-C: *Land Mobile FM or PM Communications Equipment Measurement and Performance Standards*.

(a) Connect the equipment as illustrated and measure the spurious emissions as the method as above.

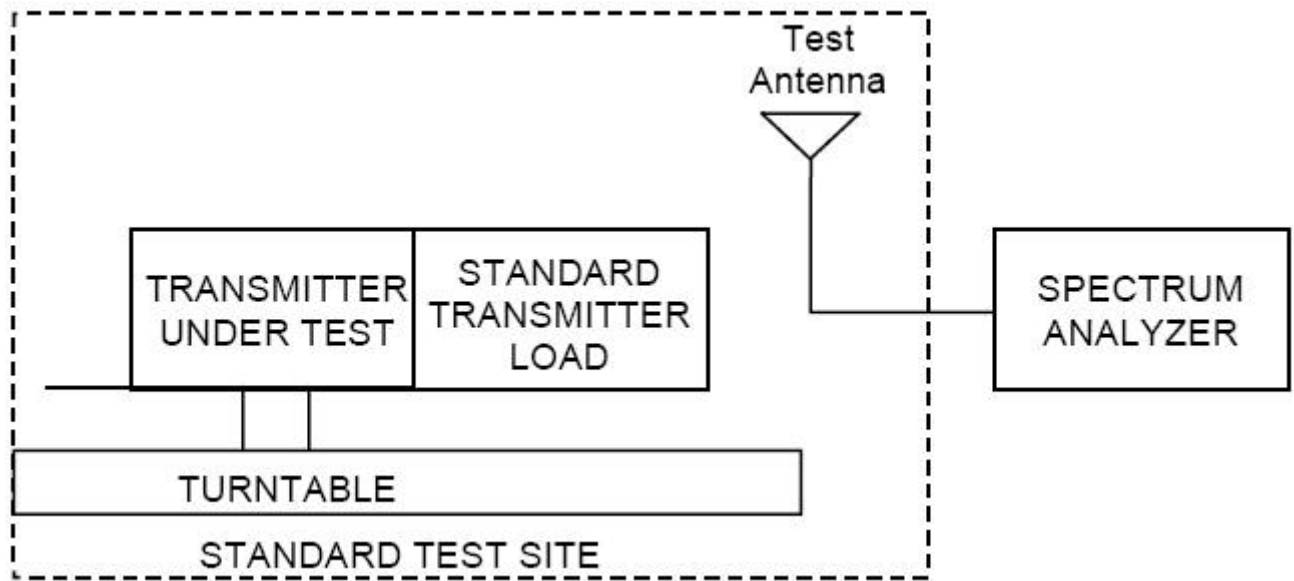

(b) Reconnect the equipment as illustrated.

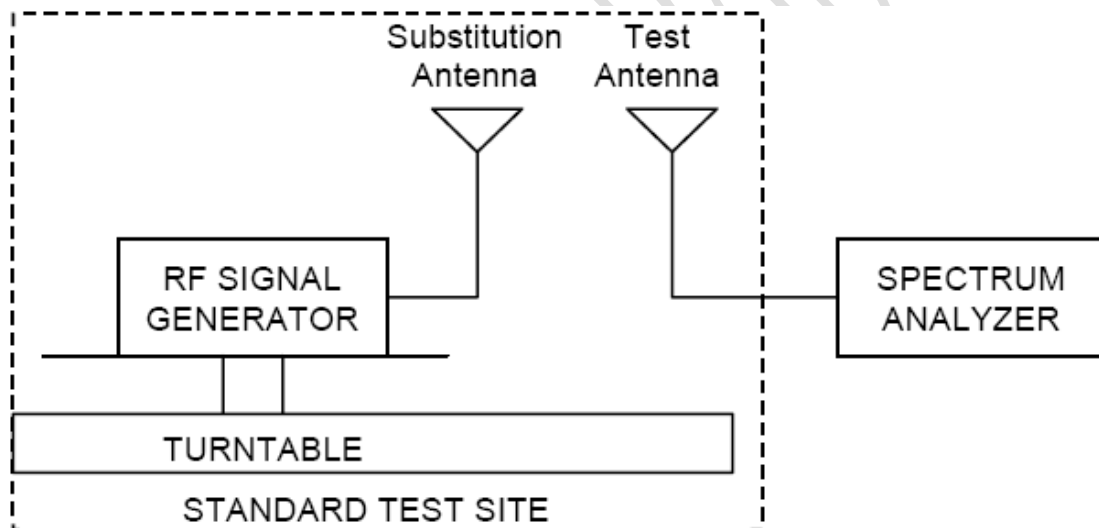

(c) Remove the transmitter and replace it with a substitution antenna. The center of the substitution antenna should be approximately at the same location as the center of the transmitter.

(d) Feed the substitution antenna at the transmitter end with a signal generator connected to the antenna by means of a non-radiating cable. With the antennas at both ends horizontally polarized, and with the signal generator tuned to a particular spurious frequency, raise and lower the test antenna to obtain a maximum reading at the spectrum analyzer. Adjust the level of the signal generator output until the previously recorded maximum reading for this set of conditions is obtained. This should be done carefully repeating the adjustment of the test antenna and generator output.

(e) Repeat step d) with both antennas vertically polarized for each spurious frequency.

(f) Calculate power in dBm into a reference ideal half-wave dipole antenna by

reducing the readings obtained in steps d) and e) by the power loss in the cable between the generator and the antenna, and further corrected for the gain of the substitution antenna used relative to an ideal half-wave dipole antenna by the following formula:

$$P_d(\text{dBm}) = P_g(\text{dBm}) - \text{cable loss (dB)} + \text{antenna gain (dB)}$$

where:

P_d is the dipole equivalent power and

P_g is the generator output power into the substitution antenna.

CITL Test Report

Test Data (GSM850 channel 190 GMSK Mode)

Frequency [MHz]	Generator output power(P _g) [dBm]	Cable loss [dB]	Antenna Gain [dB]	Spurious Emission Power (P _d) [dBm]	Antenna Polarization [H/V]
1672.8	-46.51	4.7	9.4	-41.81	V
2509.2	-50.77	5.9	10.6	-46.07	V
3345.6	-56.99	6.8	12.6	-51.19	V
4182.0	-58.04	7.8	12.6	-53.24	V
5018.4	-58.14	7.5	12.7	-52.94	V
1672.8	-48.04	4.7	9.4	-43.34	H
2509.2	-54.52	5.9	10.6	-49.82	H
3345.6	-56.57	6.8	12.6	-50.77	H
4182.0	-56.41	7.8	12.6	-51.61	H
5018.4	-56.47	7.5	12.7	-51.27	H

Test Data (GSM1900 channel 661 GMSK Mode)

Frequency [MHz]	Generator output power(P _g) [dBm]	Cable loss [dB]	Antenna Gain [dB]	Spurious Emission Power (P _d) [dBm]	Antenna Polarization [H/V]
3760.0	-44.78	7.3	12.6	-39.48	V
5840.0	-58.14	1.1	13.1	-46.14	V
7520.0	-48.47	0.8	11.5	-37.77	V
9400.0	-48.34	0.8	12.0	-37.14	V
11280.0	-49.05	0.3	11.5	-37.85	V
3760.0	-46.48	7.3	12.6	-41.18	H
5840.0	-56.78	1.1	13.1	-44.78	H
7520.0	-48.34	0.8	11.5	-37.64	H
9400.0	-48.48	0.8	12.0	-37.28	H
11280.0	-49.14	0.3	11.5	-37.94	H

Test Data (GSM850 channel 190 8PSK Mode)

Frequency [MHz]	Generator output power(P _g) [dBm]	Cable loss [dB]	Antenna Gain [dB]	Spurious Emission Power (P _d) [dBm]	Antenna Polarization [H/V]
1672.8	-38.54	4.7	9.4	-33.84	V
2509.2	-44.92	5.9	10.6	-40.22	V
3345.6	-56.84	6.8	12.6	-51.04	V
4182.0	-58.46	7.8	12.6	-53.66	V
5018.4	-58.48	7.5	12.7	-53.28	V
1672.8	-46.51	4.7	9.4	-41.81	H
2509.2	-50.77	5.9	10.6	-46.07	H
3345.6	-56.25	6.8	12.6	-50.45	H
4182.0	-56.48	7.8	12.6	-51.68	H
5018.4	-56.87	7.5	12.7	-51.67	H

Test Data (GSM1900 channel 661 8PSK Mode)

Frequency [MHz]	Generator output power(P _g) [dBm]	Cable loss [dB]	Antenna Gain [dB]	Spurious Emission Power (P _d) [dBm]	Antenna Polarization [H/V]
3760.0	-44.38	7.3	12.6	-39.08	V
5840.0	-52.68	1.1	13.1	-40.68	V
7520.0	-46.15	0.8	11.5	-35.45	V
9400.0	-48.74	0.8	12.0	-37.54	V
11280.0	-49.82	0.3	11.5	-38.62	V
3760.0	-46.45	7.3	12.6	-41.15	H
5840.0	-56.65	1.1	13.1	-44.65	H
7520.0	-46.89	0.8	11.5	-36.19	H
9400.0	-46.89	0.8	12.0	-35.69	H
11280.0	-49.47	0.3	11.5	-38.27	H

Test Data (WCDMA Band II channel 9400 QPSK Mode)

Frequency [MHz]	Generator output power(P _g) [dBm]	Cable loss [dB]	Antenna Gain [dB]	Spurious Emission Power (P _d) [dBm]	Antenna Polarization [H/V]
3760.0	-43.99	7.3	12.6	-38.69	V
5840.0	-49.26	1.1	13.1	-37.26	V
7520.0	-48.94	0.8	11.5	-38.24	V
9400.0	-48.02	0.8	12.0	-36.82	V
11280.0	-48.85	0.3	11.5	-37.65	V
3760.0	-45.99	7.3	12.6	-40.69	H
5840.0	-47.23	1.1	13.1	-35.23	H
7520.0	-46.75	0.8	11.5	-36.05	H
9400.0	-46.21	0.8	12.0	-35.01	H
11280.0	-46.25	0.3	11.5	-35.05	H

Test Data (WCDMA Band V channel 4182 QPSK Mode)

Frequency [MHz]	Generator output power(P _g) [dBm]	Cable loss [dB]	Antenna Gain [dB]	Spurious Emission Power (P _d) [dBm]	Antenna Polarization [H/V]
1672.8	-44.84	4.7	9.4	-40.14	V
2509.2	-45.54	5.9	10.6	-40.84	V
3345.6	-55.67	6.8	12.6	-49.87	V
4182.0	-53.92	7.8	12.6	-49.12	V
5018.4	-52.98	7.5	12.7	-47.78	V
1672.8	-43.72	4.7	9.4	-39.02	H
2509.2	-45.25	5.9	10.6	-40.55	H
3345.6	-53.58	6.8	12.6	-47.78	H
4182.0	-56.06	7.8	12.6	-51.26	H
5018.4	-58.32	7.5	12.7	-53.12	H

4.2 Occupied bandwidth

Specifications:	FCC Part 2.1049,22.917(b),24.238(b), RSS-Gen 6.6
Date of Test	2015-12-22
DUT Serial Number	S2/3: 359377060005203
Test conditions:	Ambient Temperature: 15°C-35°C Relative Humidity: 30%-60% Air pressure: 86-106kPa
Operation Mode	TX on, channel 128, 190, 251 and 512, 661, 810 for GSM/GPRS/EGPRS mode, channel 4132, 4182, 4233 and 9262, 9400, 9538 for WCDMA/HSUPA/HSDPA mode.
Test Results:	--

Test Setup

During the test, the EUT was controlled via the Wireless Communications Test Set to ensure max power transmission and proper modulation and measured by spectrum analyzer.

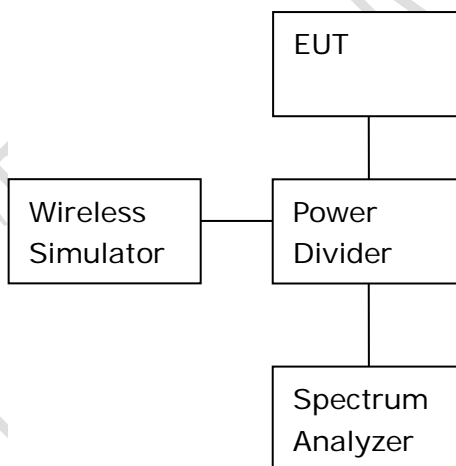

Test Method

The 99% occupied bandwidth was calculated from the spectrum analyzer. Markers in the spectrum analyzer were then placed between the calculated frequencies to show the calculated 99% power band.

Note:

None

Test Data:

GSM/GPRS/EDGE mode

	EUT channel no.	99% occupied bandwidth [kHz]
GMSK	128 (824.2MHz)	229.17
	190 (836.4MHz)	229.17
	251 (848.8MHz)	230.77
	512 (1850.2MHz)	229.17
	661 (1880 MHz)	227.56
	810 (1909.8 MHz)	232.37
8PSK	128 (824.2MHz)	243.59
	190 (836.4MHz)	241.99
	251 (848.8MHz)	243.59
	512 (1850.2MHz)	241.99
	661 (1880 MHz)	241.99
	810 (1909.8 MHz)	240.38

FCC Parts 2, 22, 24 RSS-Gen, 132, 133
Equipment: WP8548

REPORT NO.: B15W00164-FCC-RF

Graphical results for GSM/GPRS/EDGE mode:

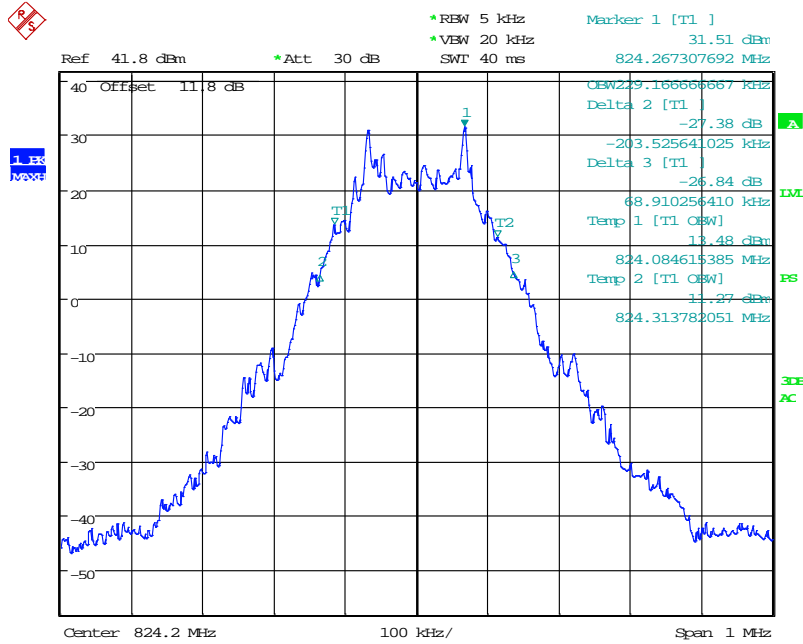

Date: 22.DEC.2015 11:33:43

GMSK Channel 128

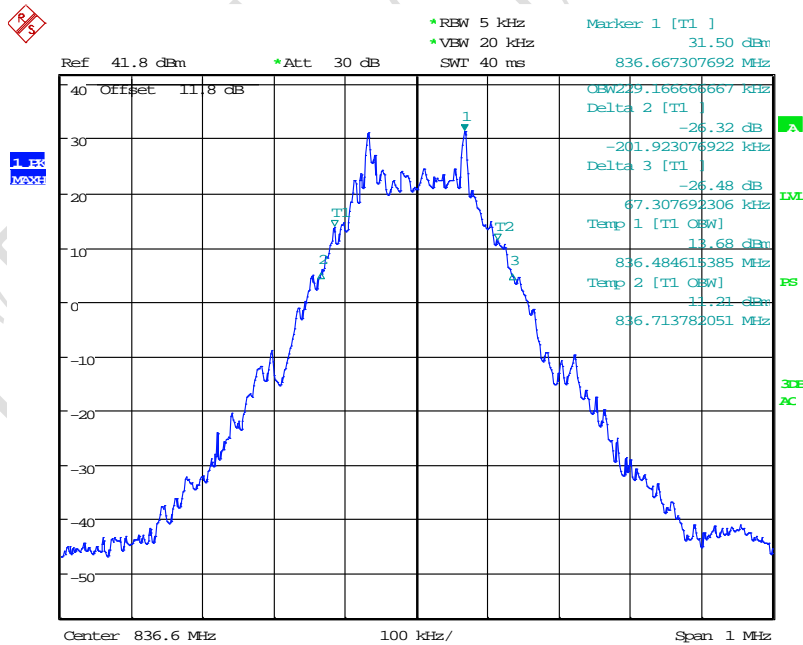

Date: 22.DEC.2015 11:35:33

GMSK Channel 190

FCC Parts 2, 22, 24 RSS-Gen, 132, 133
Equipment: WP8548

REPORT NO.: B15W00164-FCC-RF

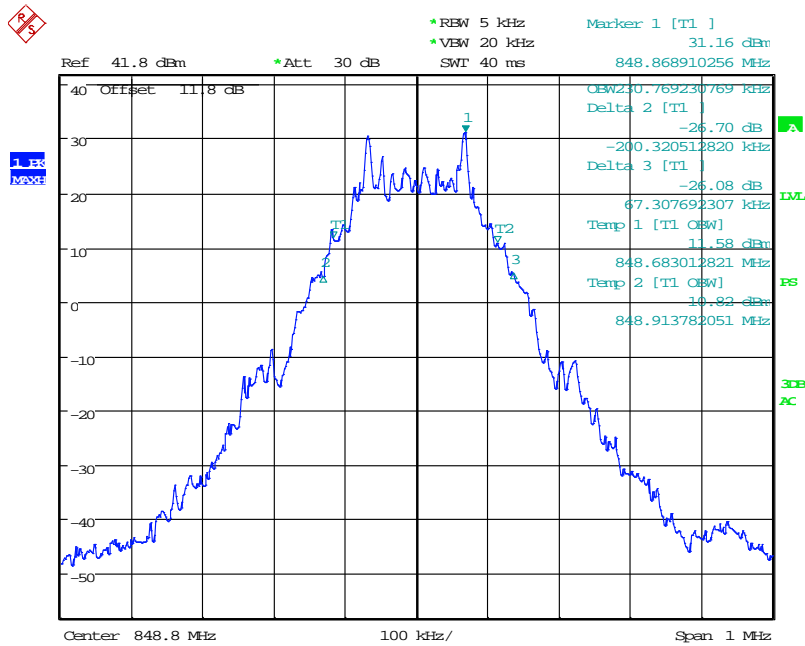

Date: 22.DEC.2015 11:36:26

GMSK Channel 251

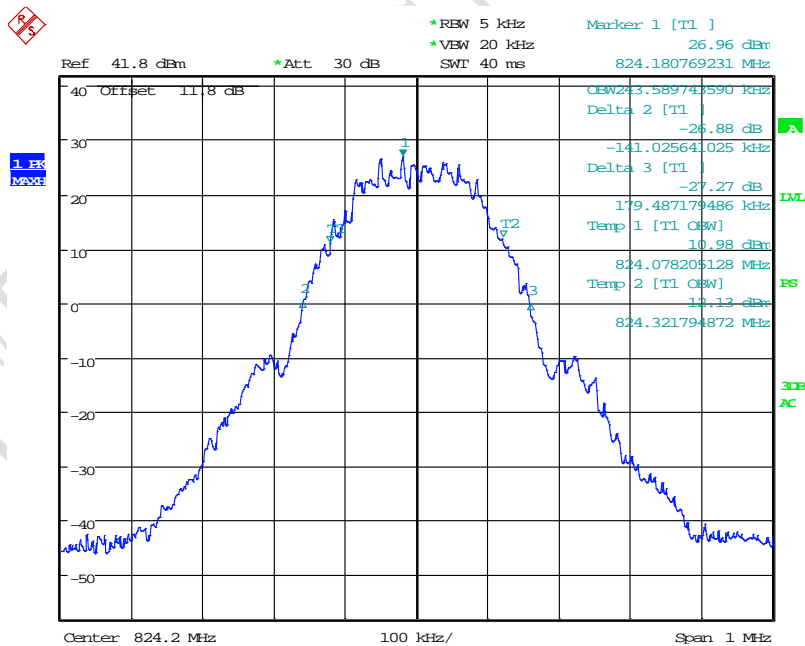

Date: 22.DEC.2015 11:39:39

8PSK Channel 128

FCC Parts 2, 22, 24 RSS-Gen, 132, 133
Equipment: WP8548

REPORT NO.: B15W00164-FCC-RF

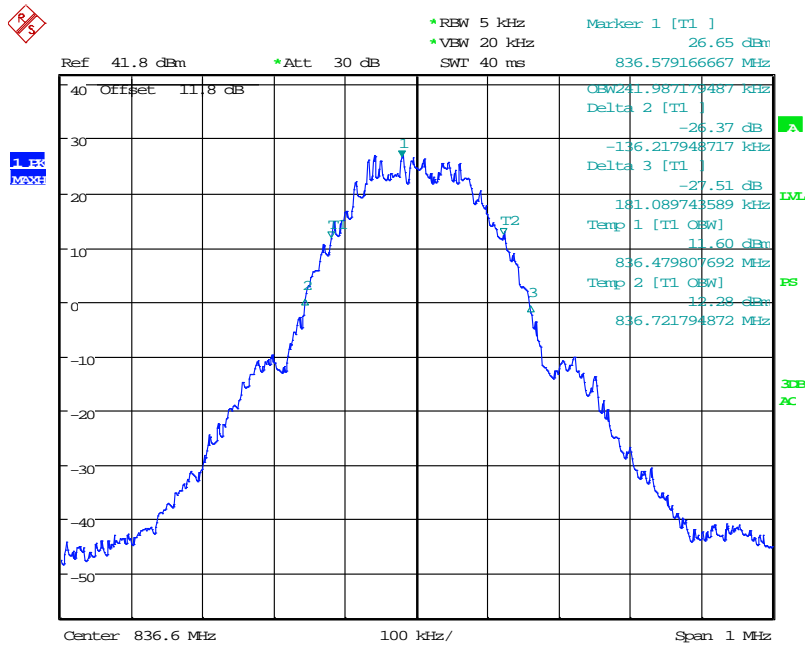

Date: 22.DEC.2015 11:38:44

8PSK Channel 190

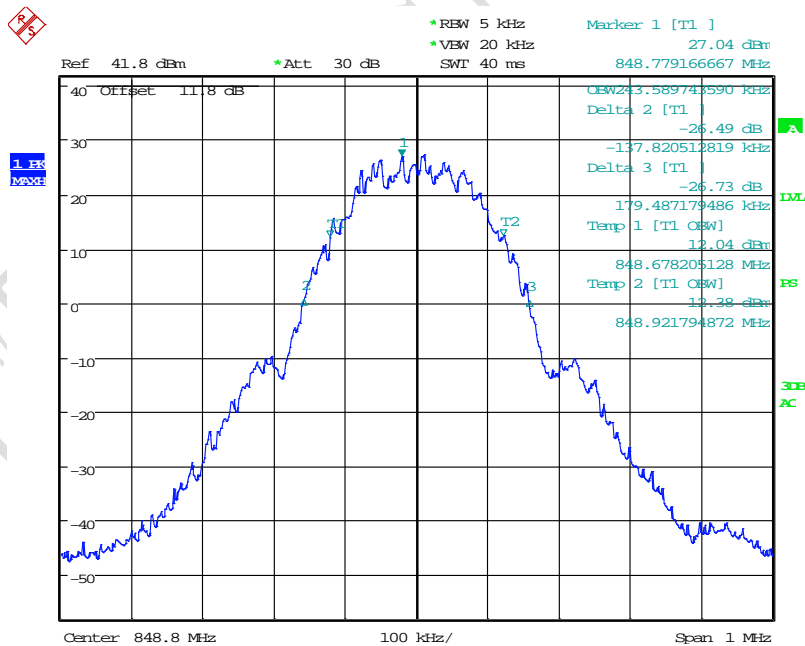

Date: 22.DEC.2015 11:37:30

8PSK Channel 251

FCC Parts 2, 22, 24 RSS-Gen, 132, 133
Equipment: WP8548

REPORT NO.: B15W00164-FCC-RF

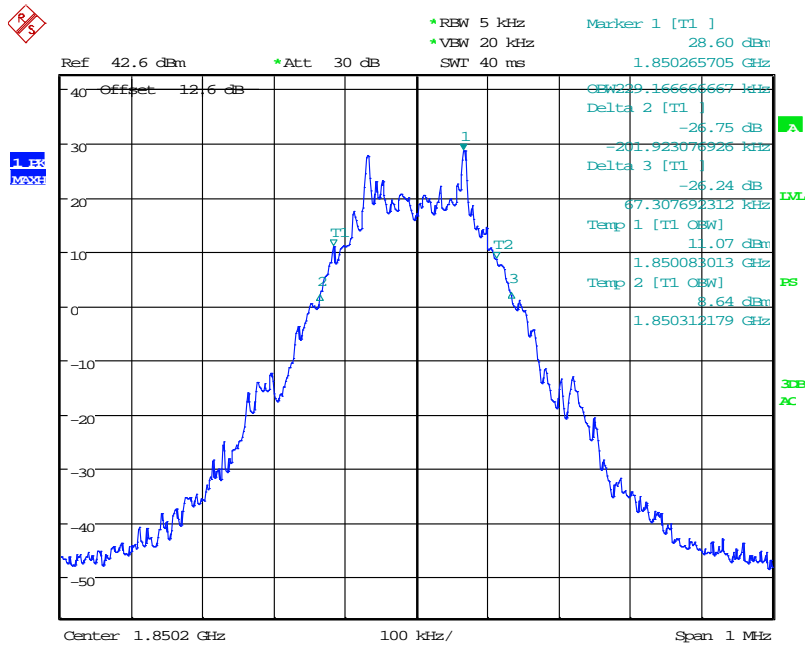

Date: 22.DEC.2015 16:42:10

GMSK Channel 512

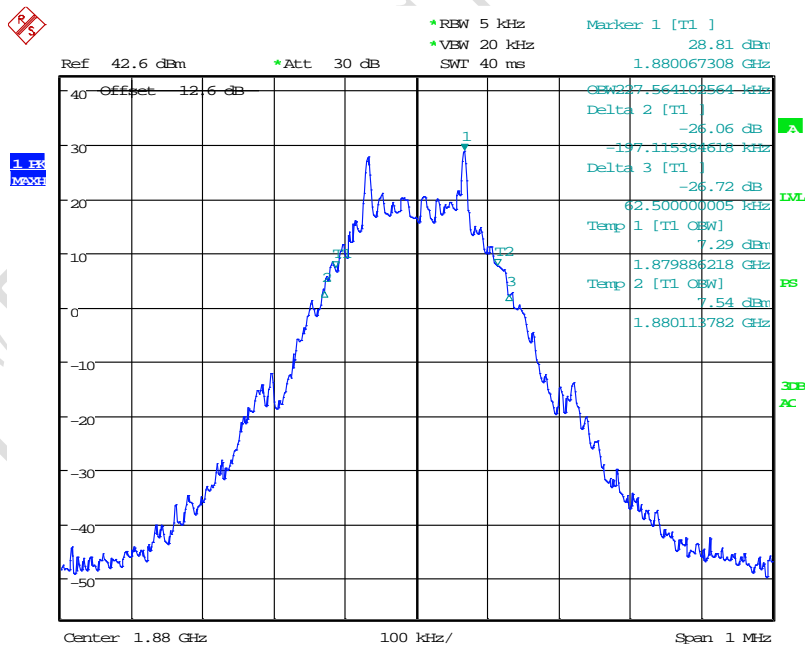

Date: 22.DEC.2015 16:47:05

GMSK Channel 661

FCC Parts 2, 22, 24 RSS-Gen, 132, 133
Equipment: WP8548

REPORT NO.: B15W00164-FCC-RF

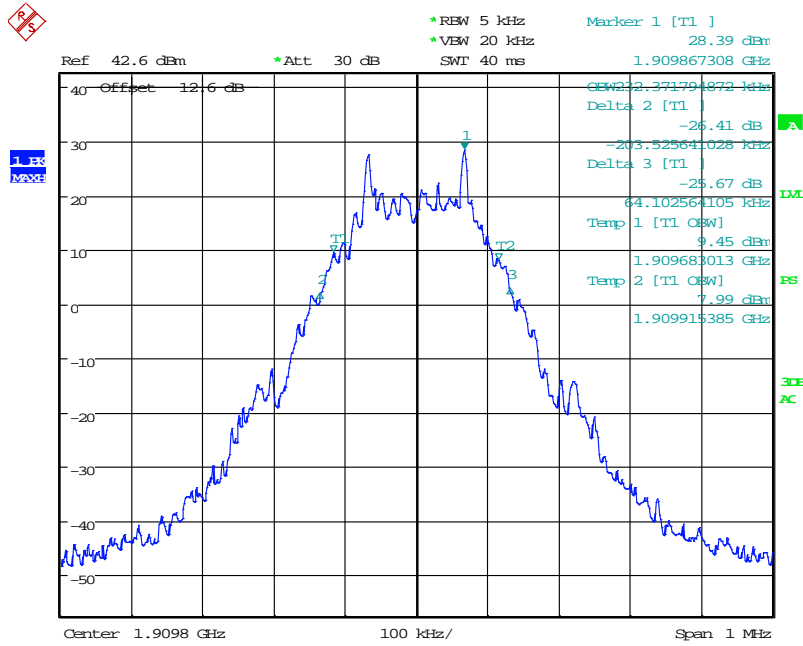

Date: 22.DEC.2015 16:46:19

GMSK Channel 810

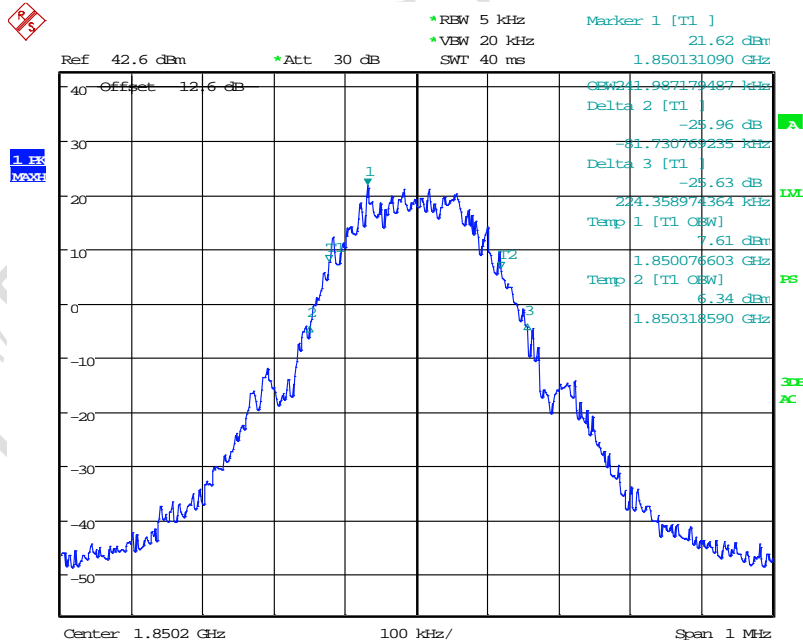

Date: 22.DEC.2015 16:43:26

8PSK Channel 512

FCC Parts 2, 22, 24 RSS-Gen, 132, 133
Equipment: WP8548

REPORT NO.: B15W00164-FCC-RF

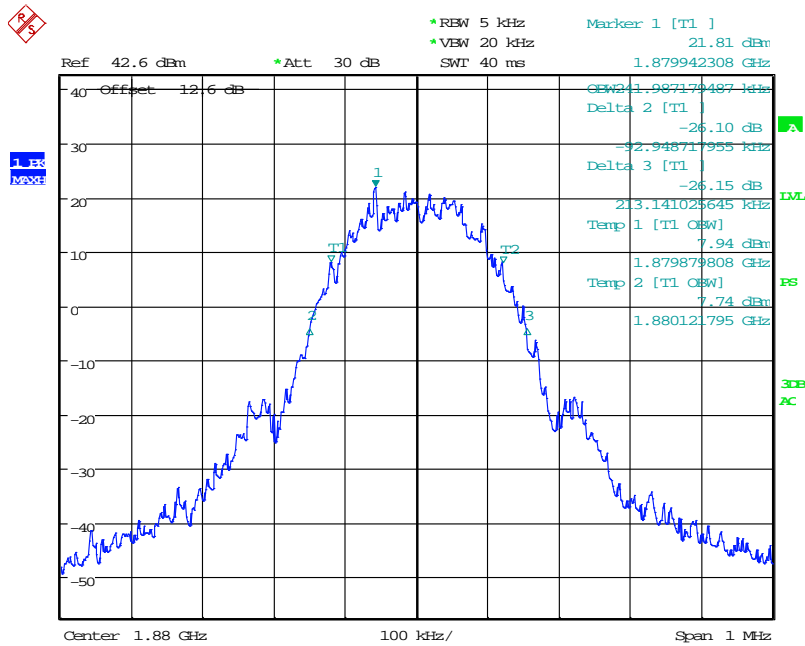

Date: 22.DEC.2015 16:44:17

8PSK Channel 661

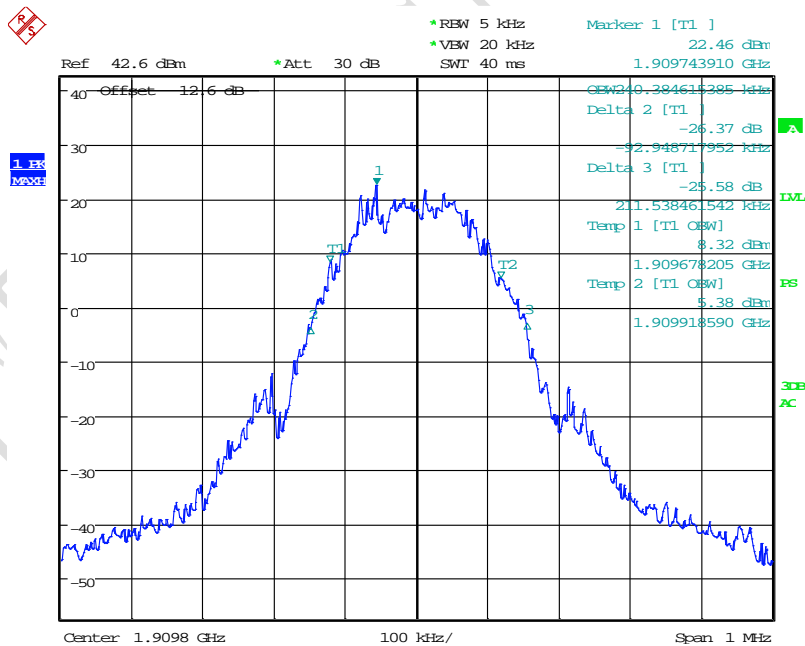

Date: 22.DEC.2015 16:45:06

8PSK Channel 810

WCDMA/HSDPA/HSUPA mode

	EUT channel no.	99% occupied bandwidth [MHz]
QPSK	4132 (826.4MHz)	4.1667
	4182 (836.4MHz)	4.1667
	4233 (846.6MHz)	4.1667
	9262 (1852.4MHz)	4.1987
	9400 (1880 MHz)	4.1667
	9538 (1907.5 MHz)	4.1667

TTL Test Report

FCC Parts 2, 22, 24 RSS-Gen, 132, 133
Equipment: WP8548

REPORT NO.: B15W00164-FCC-RF

Graphical results for WCDMA/HSDPA/HSUPA mode:

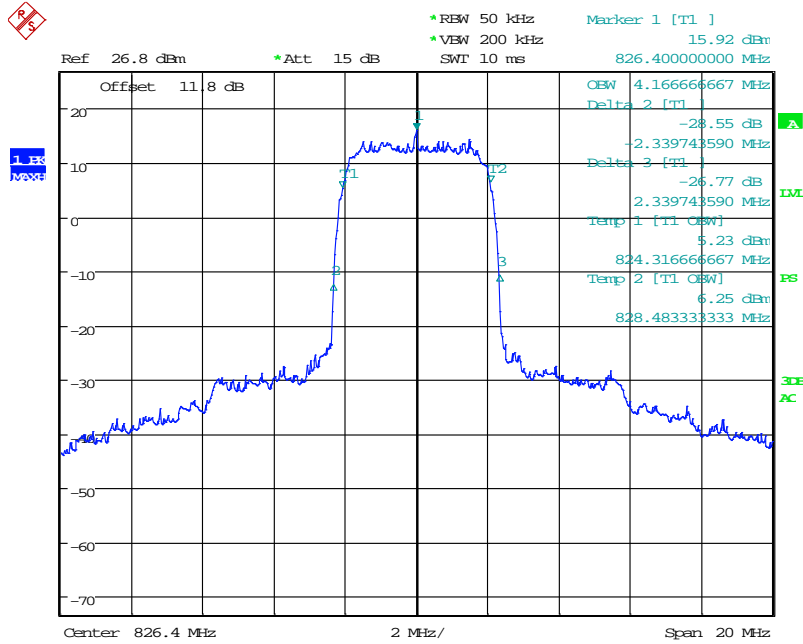

Date: 22.DEC.2015 16:22:57

QPSK Channel 4132

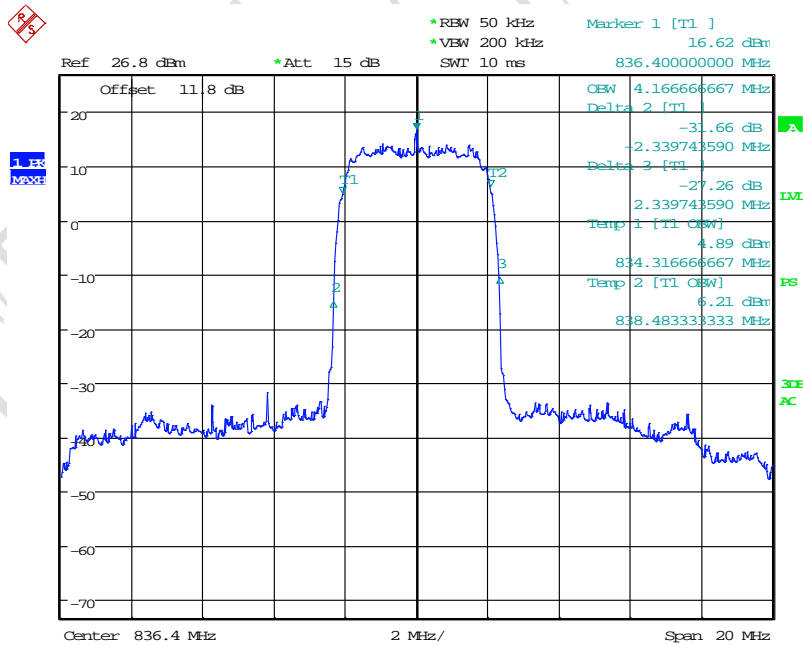

Date: 22.DEC.2015 16:24:07

QPSK Channel 4182

FCC Parts 2, 22, 24 RSS-Gen, 132, 133
Equipment: WP8548

REPORT NO.: B15W00164-FCC-RF

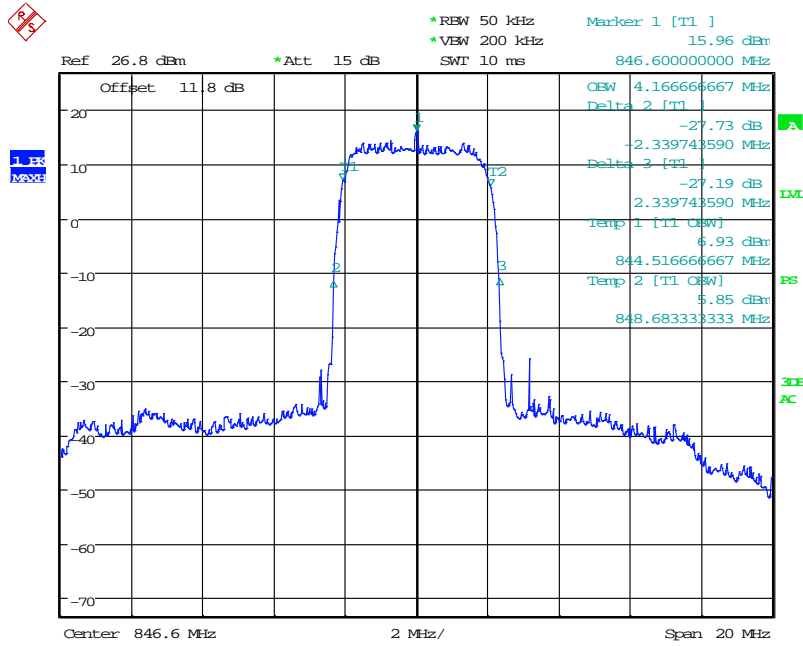

Date: 22.DEC.2015 16:24:56

QPSK Channel 4233

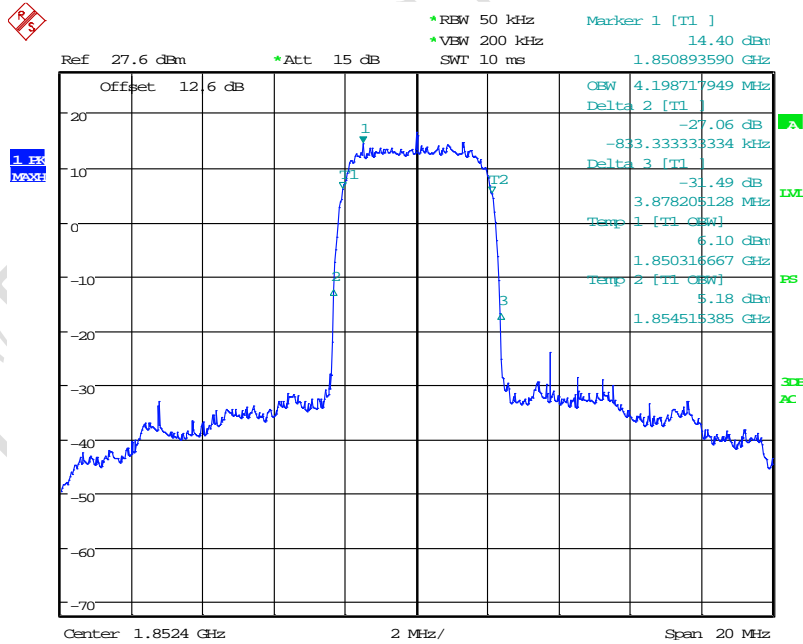

Date: 22.DEC.2015 16:34:13

QPSK Channel 9262

FCC Parts 2, 22, 24 RSS-Gen, 132, 133
Equipment: WP8548

REPORT NO.: B15W00164-FCC-RF

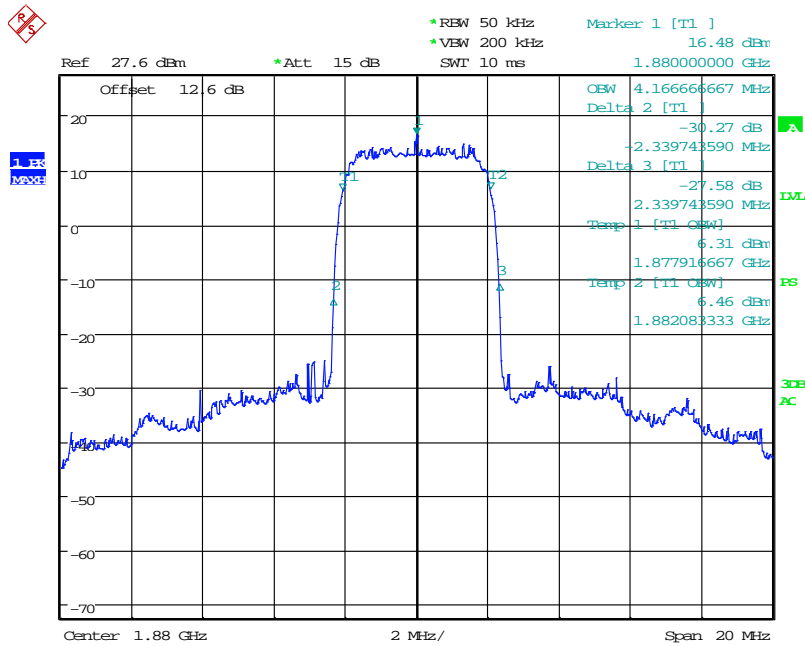

Date: 22.DEC.2015 16:33:13

QPSK Channel 9400

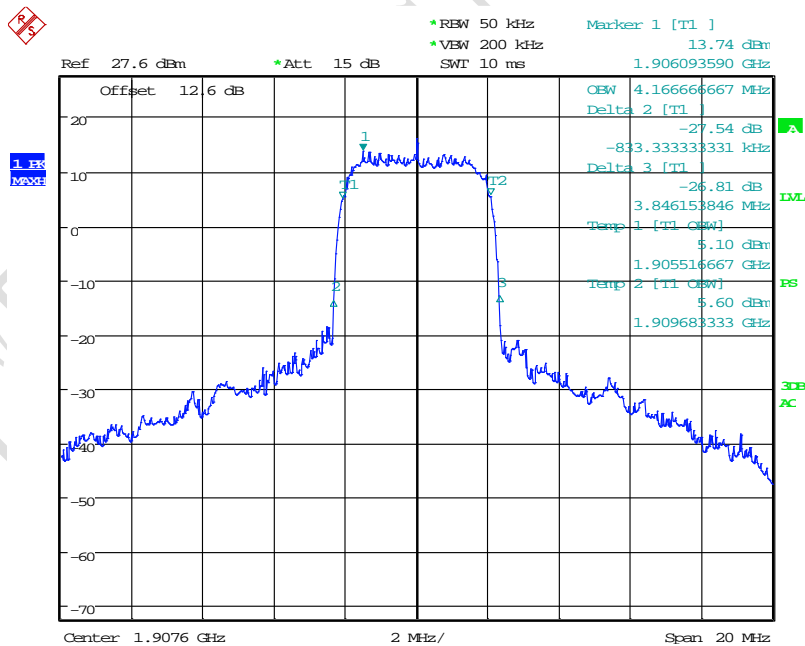

Date: 22.DEC.2015 16:32:16

QPSK Channel 9538

4.3 Frequency Stability over Temperature Variation

Specifications:	FCC Part 2.1055,22.355,24.235, RSS-132 4.3, RSS-133 6.3
Date of Test	2015-12-23
DUT Serial Number	S3/3: 359377060005716
Test conditions:	Ambient Temperature: -30°C-50°C Relative Humidity: 30%-60% Air pressure: 86-106kPa
Operation Mode	TX on, channel 190 and 661 for GSM/GPRS/EGPRS mode, channel 4182, and 9400 for WCDMA/HSUPA/HSDPA mode.
Test Results:	Pass

Limit	
Frequency deviation [ppm]	±2.5

Test Setup

The EUT was placed in a temperature chamber, demonstrated as figure T. The Wireless Telecommunications Test Set was used to set the Tx channel and power level, modulate the TX signal with different bit patterns and measure the frequency of Tx.

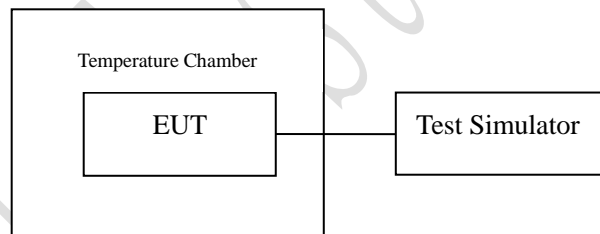

Figure T: setup for measurement of frequency stability over temperature variation

Test Method

1. The EUT was turned off and placed in the temperature chamber.
2. The temperature of the chamber was set to -30°C and allowed to stabilize.
3. The EUT temperature was allowed to stabilize for 45 minutes.
4. The EUT was turned on and set to transmit with Wireless Telecommunications Test Set.
5. The maximum transmit frequency deviation during one minute period was measured by Wireless Communications Test Set.
6. The steps 3-5 were repeated for -30°C, -20°C, -10°C, 0°C, 10°C, 20°C, 30°C, 40°C and 50°C.

Test data:

GSM/GPRS/EDGE 850 band mode

	Temperature[°C]	Offset[Hz]	Offset[ppm]	Remarks
GMSK	-30	-9.56	-0.001	Pass
	-20	-6.78	-0.001	Pass
	-10	-4.51	-0.001	Pass
	0	-5.45	-0.001	Pass
	10	-3.52	-0.001	Pass
	20	-6.26	-0.001	Pass
	30	-4.81	-0.001	Pass
	40	-6.82	-0.001	Pass
	50	-8.56	-0.001	Pass
8PSK	-30	-7.49	-0.001	Pass
	-20	-6.54	-0.001	Pass
	-10	-5.91	-0.001	Pass
	0	-6.01	-0.001	Pass
	10	-7.59	-0.001	Pass
	20	-7.33	-0.001	Pass
	30	-3.52	-0.001	Pass
	40	-6.04	-0.001	Pass
	50	-5.78	-0.001	Pass

GSM/GPRS/EDGE 1900 band mode

	Temperature[°C]	Offset[Hz]	Offset[ppm]	Remarks
GMSK	-30	15.59	0.001	Pass
	-20	10.11	0.001	Pass
	-10	5.88	0.001	Pass
	0	-4.36	-0.001	Pass
	10	-5.75	-0.001	Pass
	20	-5.17	-0.001	Pass
	30	-6.20	-0.001	Pass
	40	-5.84	-0.001	Pass
	50	-5.23	-0.001	Pass
8PSK	-30	-13.01	-0.001	Pass
	-20	-9.96	-0.001	Pass
	-10	-6.52	-0.001	Pass
	0	-7.20	-0.001	Pass
	10	-8.75	-0.001	Pass
	20	-12.17	-0.001	Pass
	30	-5.55	-0.001	Pass
	40	-5.59	-0.001	Pass

	50	-9.14	-0.001	Pass
--	----	-------	--------	------

WCDMA/HSDPA/HSUPA FDD 850MHz band mode:

	Temperature[°C]	Offset[Hz]	Offset[ppm]	Remarks
QPSK	-30	-8.34	-0.001	Pass
	-20	-6.07	-0.001	Pass
	-10	-6.00	-0.001	Pass
	0	-4.97	-0.001	Pass
	10	3.55	0.001	Pass
	20	0.81	0.001	Pass
	30	2.56	0.001	Pass
	40	1.82	0.001	Pass
	50	-5.45	-0.001	Pass

WCDMA/HSDPA/HSUPA FDD 1900MHz band mode:

	Temperature[°C]	Offset[Hz]	Offset[ppm]	Remarks
QPSK	-30	-7.98	-0.001	Pass
	-20	-8.18	-0.001	Pass
	-10	-7.42	-0.001	Pass
	0	-8.21	-0.001	Pass
	10	-7.88	-0.001	Pass
	20	-7.71	-0.001	Pass
	30	-8.08	-0.001	Pass
	40	-8.05	-0.001	Pass
	50	-5.87	-0.001	Pass

4.4 Frequency Stability over Voltage Variation

Specifications:	FCC Part 2.1055,22.355,24.235, RSS-132 4.3, RSS-133 6.3
Date of Test	2015-12-23
DUT Serial Number	S3/3:359377060005716
Test conditions:	Ambient Temperature: 15°C-35°C Relative Humidity: 30%-60% Air pressure: 86-106kPa
Operation Mode	TX on, channel 190 and 661 for GSM/GPRS/EGPRS mode, channel 4182, and 9400 for WCDMA/HSUPA/HSDPA mode.
Test Results:	Pass

Limit	
Frequency deviation [ppm]	±2.5

Test Setup

The EUT was placed in a shielding chamber and powered by an adjustable power supply, demonstrated as figure V. A Wireless Telecommunications Test Set was used to set the TX channel and power level, modulate the TX signal with different bit patterns and measure the frequency of TX.

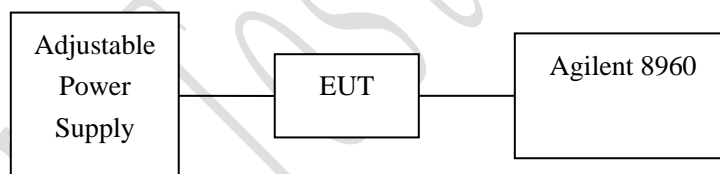

Figure V: test setup for measurement of frequency stability over voltage variation

Test Method

The EUT was powered by the adjustable power supply. The frequency stability is measured by the Wireless Telecommunications Test Set.

Test data:

GSM/GPRS/EDGE 850MHz band GMSK mode

Voltage (V)	Offset[Hz]	Offset[ppm]	Remarks
3.4	-5.81	-0.001	Pass
3.7	-5.42	-0.001	Pass
4.3	-4.20	-0.001	Pass

GSM/GPRS/EDGE 850MHz band 8PSK mode

Voltage (V)	Offset[Hz]	Offset[ppm]	Remarks
3.4	-6.88	-0.001	Pass
3.7	-8.65	-0.001	Pass
4.3	-5.20	-0.001	Pass

GSM/GPRS/EDGE 1900MHz band GMSK mode

Voltage (V)	Offset[Hz]	Offset[ppm]	Remarks
3.4	-9.91	-0.001	Pass
3.7	-12.95	-0.001	Pass
4.3	-11.17	-0.001	Pass

GSM/GPRS/EDGE 1900MHz band 8PSK mode

Voltage (V)	Offset[Hz]	Offset[ppm]	Remarks
3.4	-8.04	-0.001	Pass
3.7	-5.91	-0.001	Pass
4.3	-10.36	-0.001	Pass

WCDMA/HSDPA/HSUPA FDD 850MHz band QPSK mode:

Voltage (V)	Offset[Hz]	Offset[ppm]	Remarks
3.4	0.86	0.001	Pass
3.7	-0.77	-0.001	Pass
4.3	0.22	0.001	Pass

WCDMA/HSDPA/HSUPA FDD 1900MHz band QPSK mode:

Voltage (V)	Offset[Hz]	Offset[ppm]	Remarks
3.4	-5.35	-0.001	Pass
3.7	-7.42	-0.001	Pass
4.3	-8.00	-0.001	Pass

4.5 Conducted RF Power Output

Specifications:	FCC Part 2.1046,22.913(a),24.232(c), RSS-132 4.4, RSS-133 6.4
Date of Tests	2015-12-21-2016-2-4
DUT Serial Number	S2/3:359377060005203
Test conditions:	Ambient Temperature: 15°C-35°C Relative Humidity: 30%-60% Air pressure: 86-106kPa
Operation Mode	TX on, channel 128, 190, 251 and 512, 661, 810 for GSM/GPRS/EGPRS mode, channel 4132, 4182, 4233 and 9262, 9400, 9538 for WCDMA/HSUPA/HSDPA mode.
Test Results:	Pass

Limit Level Construction:

According to Part 22.913(a), the ERP of mobile transmitters and auxiliary test transmitters must not exceed 7 Watts.
According to Part24.232(c), mobile and portable stations are limited to 2 watts EIRP and the equipment must employ a means for limiting power to the minimum necessary for successful communications.

Test Setup:

During the test, the EUT was controlled via the Wireless Communications Test Set to ensure max power transmission and proper modulation and measured by spectrum analyzer.

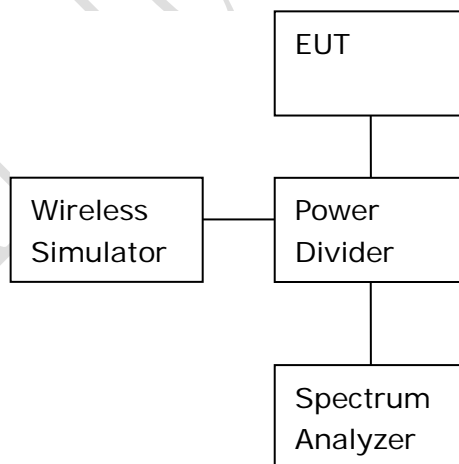

Test Method

- 1) The EUT was coupled to the spectrum analyzer and the base station simulator through a power divider. The lost of the cables the test system is calibrated to correct the readings.
- 2) The spectrum analyzer was set to Maxpeak Detector function and Maximum hold mode.

3) The resolution bandwidth of the spectrum analyzer was comparable to the emission bandwidth.

Note:

None

Test Results:

GSM 850 band GMSK mode

Channel No.	Maximum output power(pk) [dBm]			
	1TS	2TS	3TS	4TS
128 (824.2MHz)	32.49	31.87	29.15	27.36
190 (836.6MHz)	32.69	31.69	29.47	27.13
251 (848.8MHz)	32.65	31.77	29.39	27.34

GSM 850 band 8PSK mode

Channel No.	Maximum output power(pk) [dBm]			
	1TS	2TS	3TS	4TS
128 (824.2MHz)	27.32	26.91	26.55	26.15
190 (836.6MHz)	27.14	26.91	26.41	26.14
251 (848.8MHz)	27.25	26.84	26.31	26.09

GSM 1900 band GMSK mode

Channel No.	Maximum output power(pk) [dBm]			
	1TS	2TS	3TS	4TS
512 (1850.2MHz)	29.92	29.22	26.16	26.15
661 (1880.0MHz)	29.67	28.81	26.63	25.47
810 (1909.8MHz)	29.45	28.47	26.51	25.31

GSM 1900 band 8PSK mode

Channel No.	Maximum output power(pk) [dBm]			
	1TS	2TS	3TS	4TS
512 (1850.2MHz)	26.18	26.10	25.65	25.46
661 (1880.0MHz)	26.31	26.26	25.84	25.60
810 (1909.8MHz)	26.48	26.23	25.91	25.75

WCDMA V band mode

		Maximum output power(pk) [dBm]			Maximum output power(RMS) [dBm]		
mode	3GPP Subtest	4132	4182	4233	4132	4182	4233
RMC	--	25.83	25.74	26.43	22.89	22.77	23.36
HSDPA	1	25.37	25.25	25.88	22.32	22.19	22.82
	2	26.58	26.35	26.99	22.58	22.14	22.92
	3	26.58	26.17	26.69	22.30	21.88	22.14
	4	26.68	26.36	26.95	21.81	21.86	22.21
HSUPA (QPSK)	1	26.99	26.78	25.75	22.17	22.21	22.14
	2	26.97	26.85	25.78	22.26	22.10	22.10
	3	26.91	26.84	25.77	22.16	22.17	22.08
	4	26.89	26.82	25.72	22.15	22.21	22.06
	5	26.87	26.80	25.74	22.34	22.21	22.06

WCDMA II band mode

		Maximum output power(pk) [dBm]			Maximum output power(RMS) [dBm]		
mode	3GPP Subtest	9262	9400	9538	9262	9400	9538
RMC	--	26.03	26.14	26.32	22.99	23.08	23.32
HSDPA	1	25.41	26.06	26.11	22.42	22.80	22.68
	2	26.66	26.86	26.98	22.65	23.01	23.15
	3	26.60	26.91	26.86	22.04	22.09	22.57
	4	26.01	27.01	27.23	22.01	22.29	22.31
HSUPA (QPSK)	1	25.50	25.68	25.93	22.56	22.65	22.65
	2	25.44	25.65	25.83	22.53	22.69	22.60
	3	25.56	25.66	25.75	22.59	22.71	22.65
	4	25.63	25.63	25.84	22.58	22.70	22.63
	5	25.52	25.69	25.73	22.53	22.64	22.60

4.6 Conducted Spurious Emission

Specifications:	FCC Part 2.1051,22.917,24.238, RSS-132 4.5, RSS-133 6.5
Date of Tests	2015-12-22
DUT Serial Number	S2/3: 359377060005203
Test conditions:	Ambient Temperature: 15°C-35°C Relative Humidity: 30%-60% Air pressure: 86-106kPa
Operation Mode	TX on, channel 128, 190, 251 and 512, 661, 810 for GSM/GPRS/EGPRS mode, channel 4132, 4182, 4233 and 9262, 9400, 9538 for WCDMA/HSUPA/HSDPA mode.
Test Results:	Pass

Limit Level Construction:

According to Part 22.917 (a), i.e., Out of band emissions. The power of any emission outside of the authorized operating frequency ranges must be attenuated below the transmitting power (P) by a factor of at least $43 + 10 \log(P)$ dB.

According to Part 24.238 (a), i.e., Out of band emissions. The power of any emission outside of the authorized operating frequency ranges must be attenuated below the transmitting power (P) by a factor of at least $43 + 10 \log(P)$ dB, so the limit level is:
 $P(\text{dBm}) - (43 + 10 \log(P)) \text{ dB} = -13\text{dBm}$

Limits for Radiated spurious emissions(UE)

Frequency range	Limit Level /Resolution Bandwidth
30 MHz to 20000 MHz	-13dBm/1MHz

Test Setup:

During the test, the EUT was controlled via the Wireless Communications Test Set to ensure max power transmission and proper modulation and measured by spectrum analyzer.

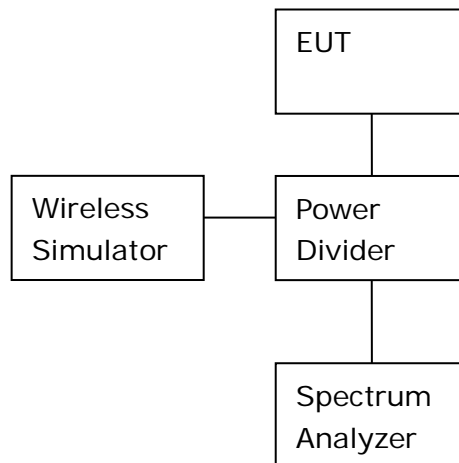

Test Method

The measurement was performed accordance with section 2.2.13 of ANSI/TIA-603-B-2002: *Land Mobile FM or PM Communications Equipment Measurement and Performance Standards*.

The following steps outline the procedure used to measure the conducted emissions from the EUT.

1. Determine frequency range for measurements: From CFR 2.1057 the spectrum should be investigated from the lowest radio frequency generated in the equipment up to at least the 10th harmonic of the carrier frequency.

Note:

None

Graphical results :

4.6.1 GSM850 Conducted Spurious Emission Results

GMSK, Low channel, 824.200 MHz, 30MHz to 1GHz

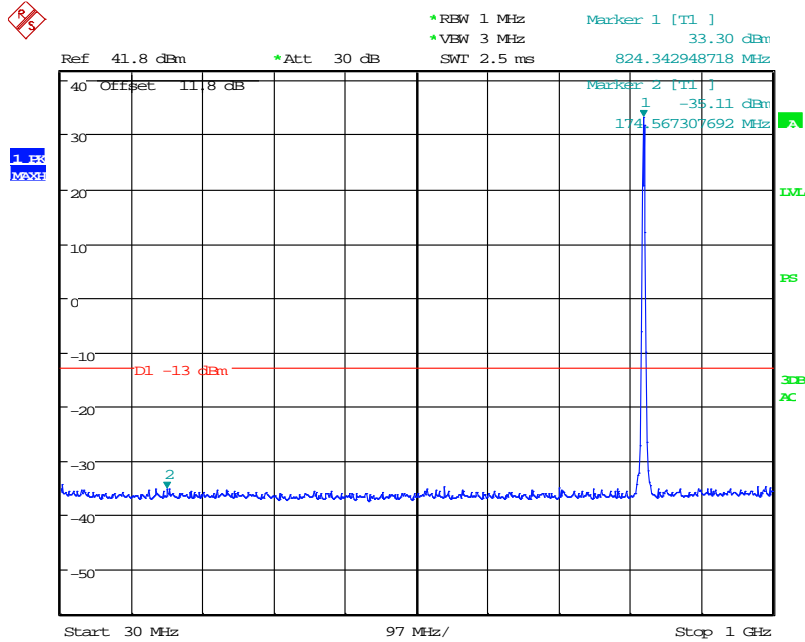

Date: 22.DEC.2015 16:57:02

Note: The strong emission shown in each case is the carrier signal.

GMSK, Low channel, 824.200 MHz, 1GHz to 10GHz

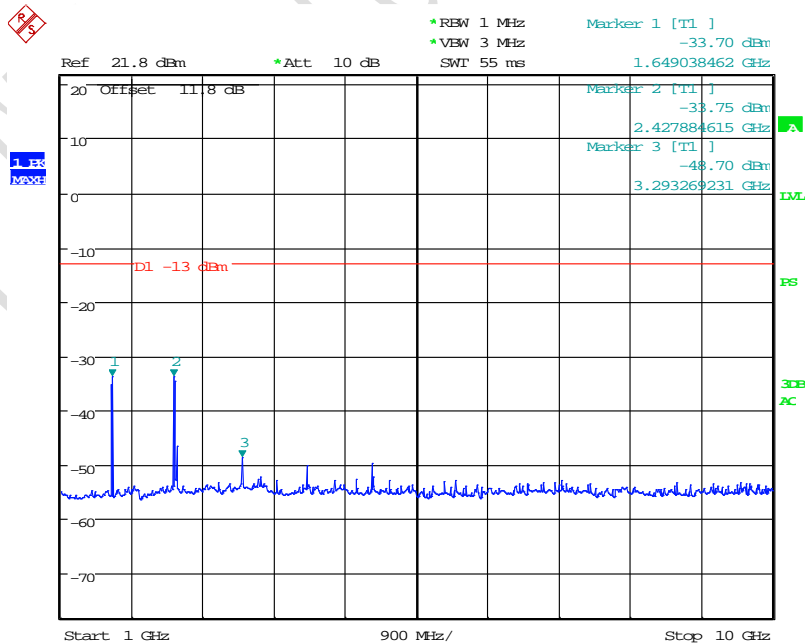

Date: 22.DEC.2015 17:02:12

FCC Parts 2, 22, 24 RSS-Gen, 132, 133
Equipment: WP8548

REPORT NO.: B15W00164-FCC-RF

GMSK, Low channel, 824.200 MHz, 10GHz to 20GHz

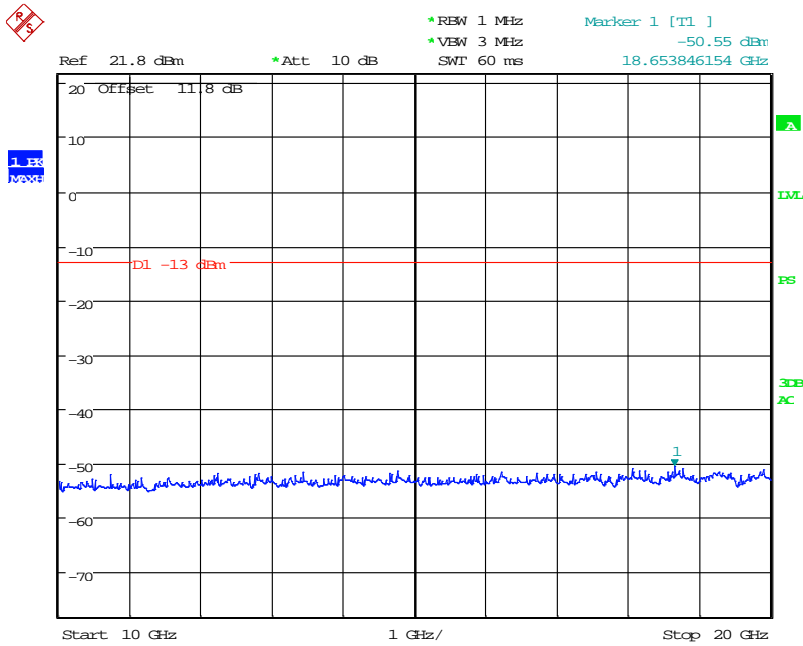

Date: 22.DEC.2015 17:02:34

GMSK, Mid Channel, 836.6 MHz, 30MHz to 1GHz

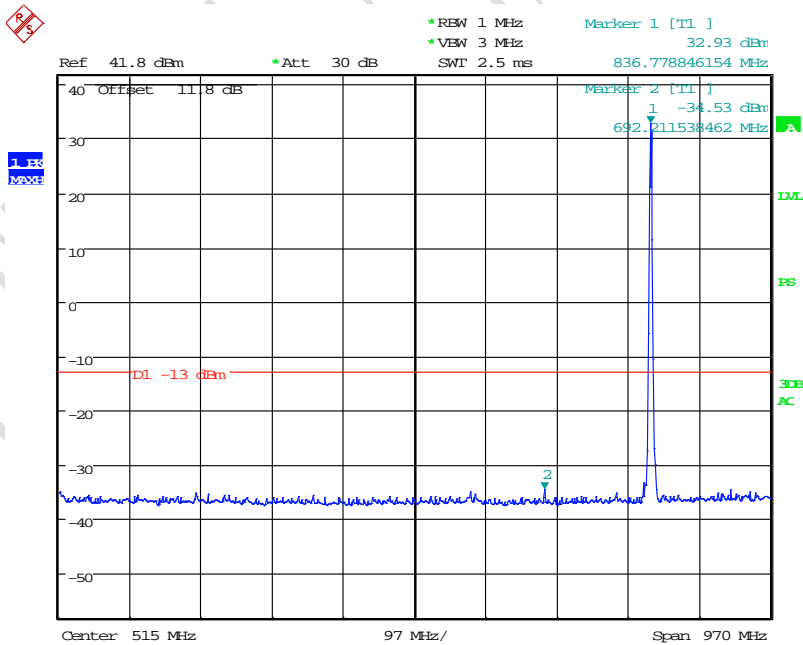

Date: 22.DEC.2015 16:57:29

Note: The strong emission shown in each case is the carrier signal.

FCC Parts 2, 22, 24 RSS-Gen, 132, 133
Equipment: WP8548

REPORT NO.: B15W00164-FCC-RF

GMSK, Mid Channel, 836.6 MHz, 1GHz to 10GHz

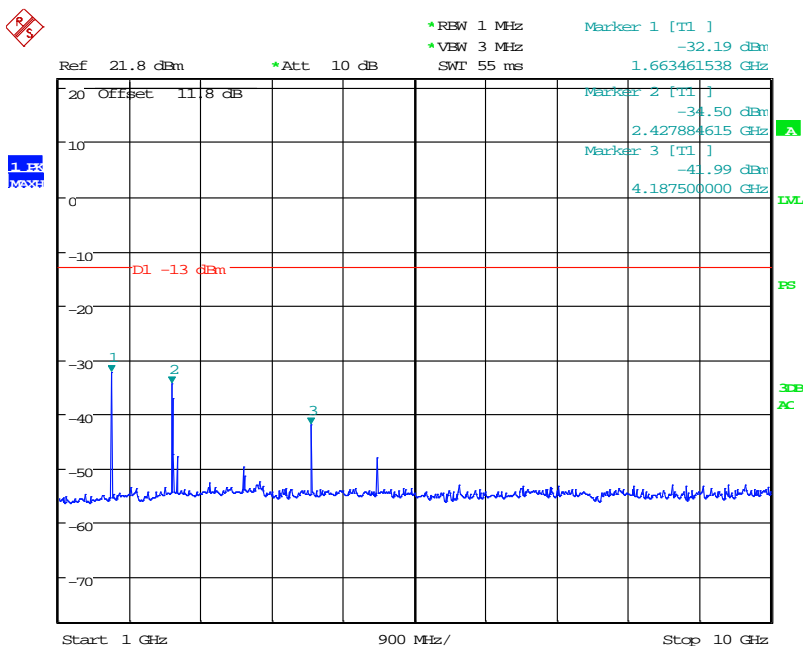

Date: 22.DEC.2015 17:01:42

GMSK, Mid Channel, 836.6 MHz, 10GHz to 20GHz

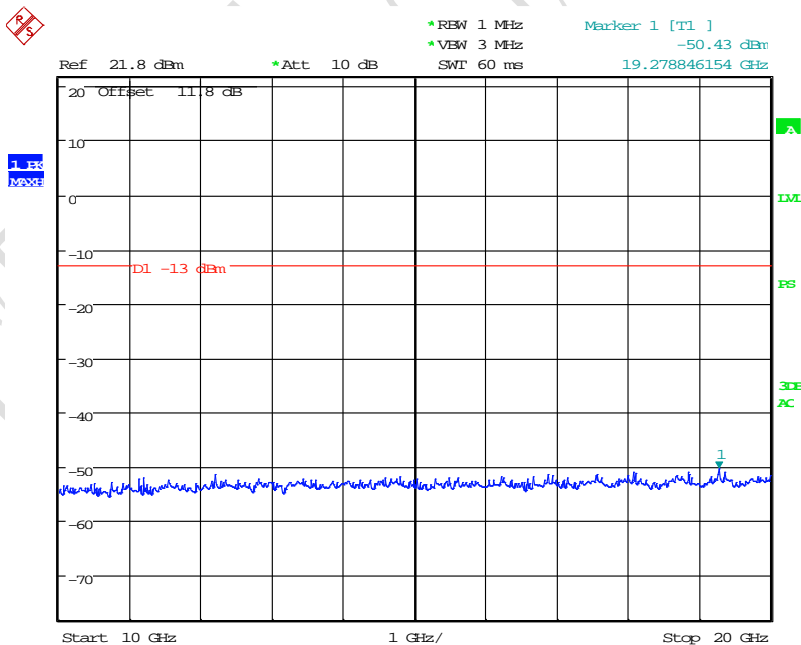

Date: 22.DEC.2015 17:02:57

FCC Parts 2, 22, 24 RSS-Gen, 132, 133
Equipment: WP8548

REPORT NO.: B15W00164-FCC-RF

GMSK, High Channel, 848.8 MHz, 30MHz to 1GHz

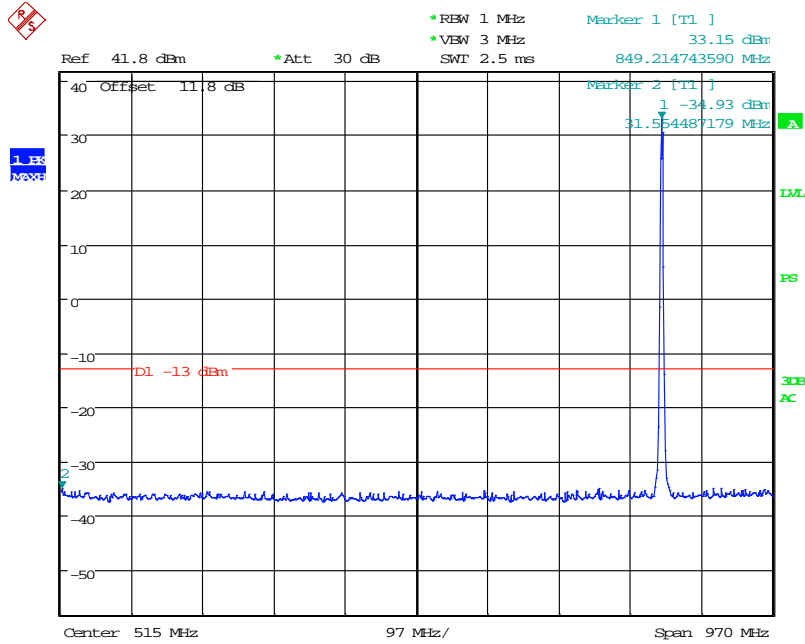

Date: 22.DEC.2015 16:58:02

Note: The strong emission shown in each case is the carrier signal.

GMSK, High Channel, 848.8 MHz, 1GHz to 10GHz

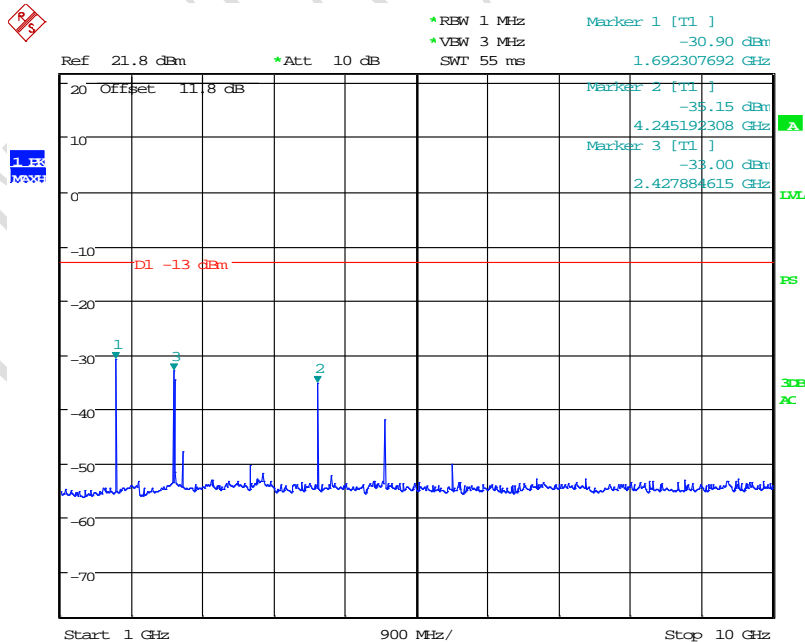

Date: 22.DEC.2015 16:59:57

FCC Parts 2, 22, 24 RSS-Gen, 132, 133
Equipment: WP8548

REPORT NO.: B15W00164-FCC-RF

GMSK, High Channel, 848.8 MHz, 10GHz to 20GHz

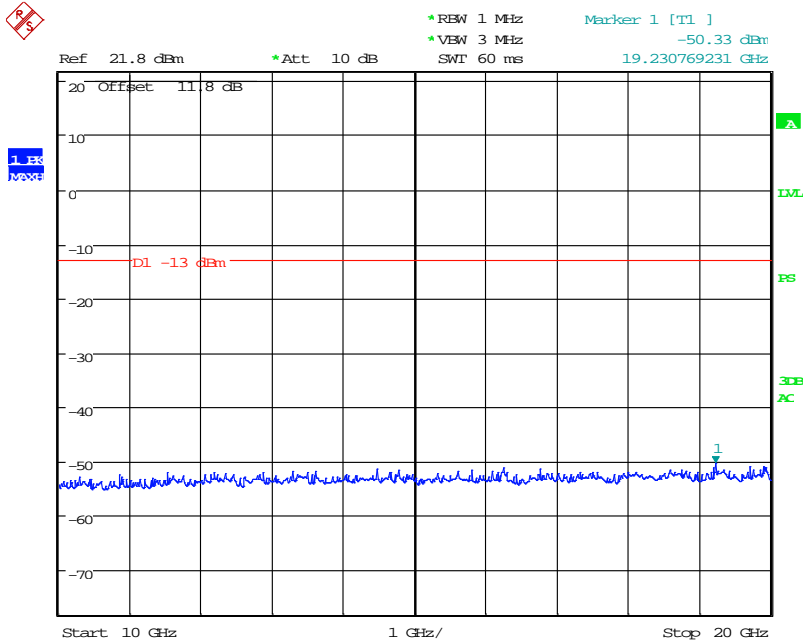

Date: 22.DEC.2015 17:03:17

8PSK, Low channel, 824.200 MHz, 30MHz to 1GHz

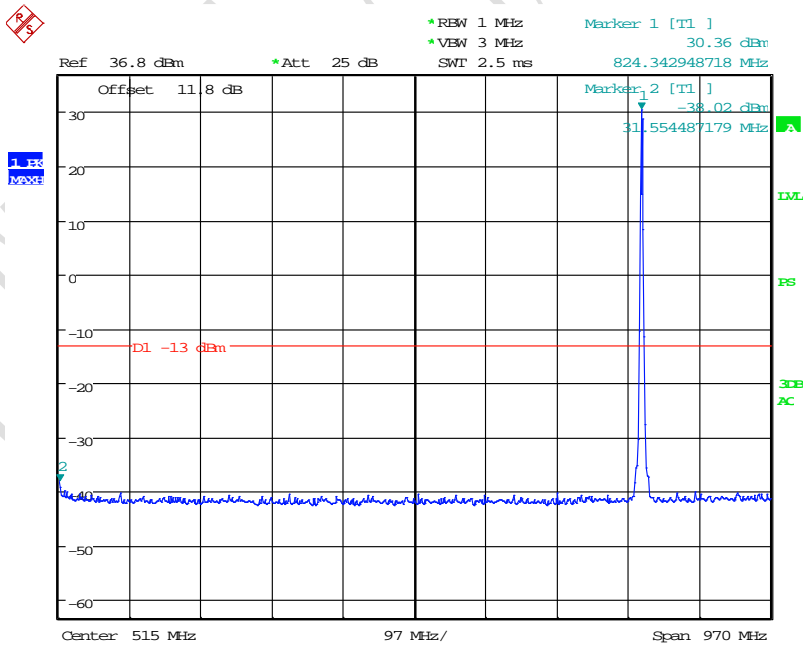

Date: 22.DEC.2015 17:09:02

Note: The strong emission shown in each case is the carrier signal.

FCC Parts 2, 22, 24 RSS-Gen, 132, 133
Equipment: WP8548

REPORT NO.: B15W00164-FCC-RF

8PSK, Low channel, 824.200 MHz, 1GHz to 10GHz

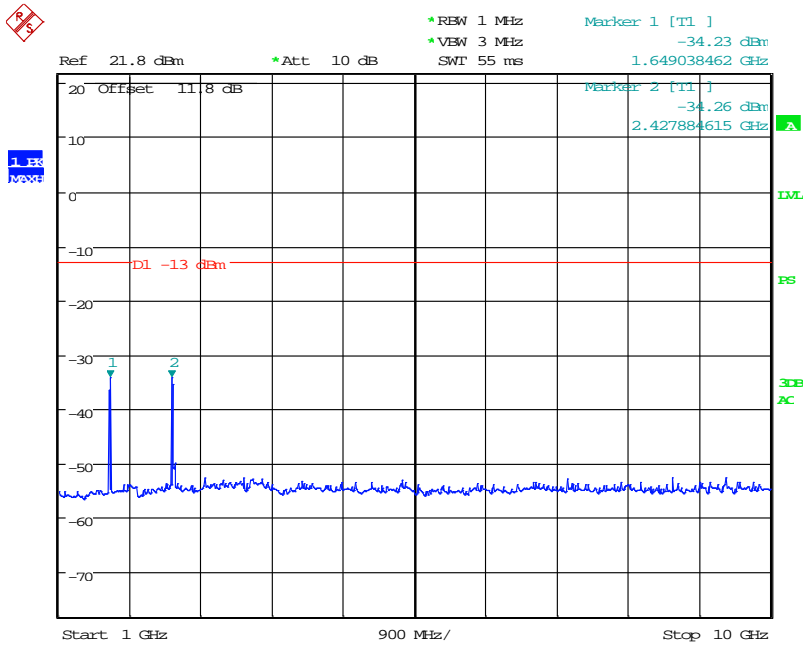

Date: 22.DEC.2015 17:06:04

8PSK, Low channel, 824.200 MHz, 10GHz to 20GHz

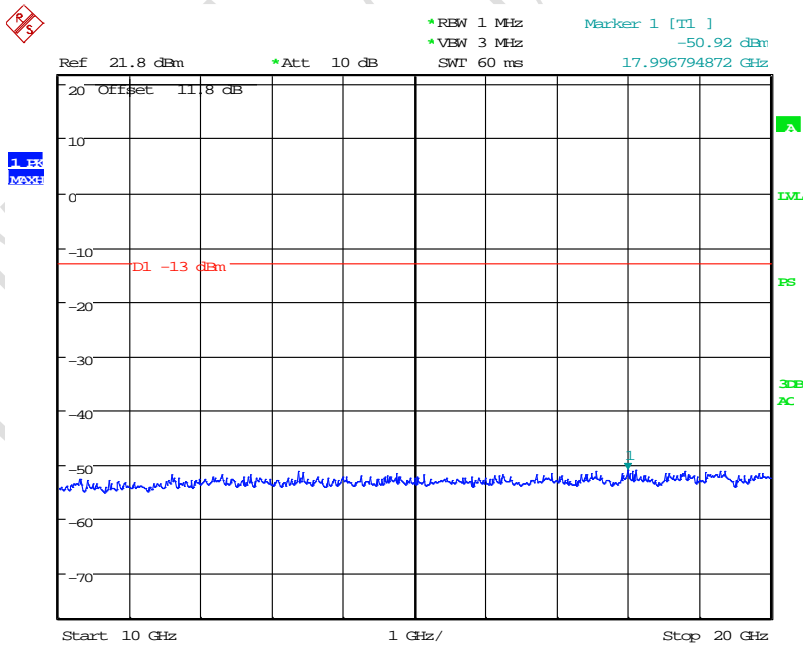

Date: 22.DEC.2015 17:04:52

FCC Parts 2, 22, 24 RSS-Gen, 132, 133
Equipment: WP8548

REPORT NO.: B15W00164-FCC-RF

8PSK, Mid Channel, 836.6 MHz, 30MHz to 1GHz

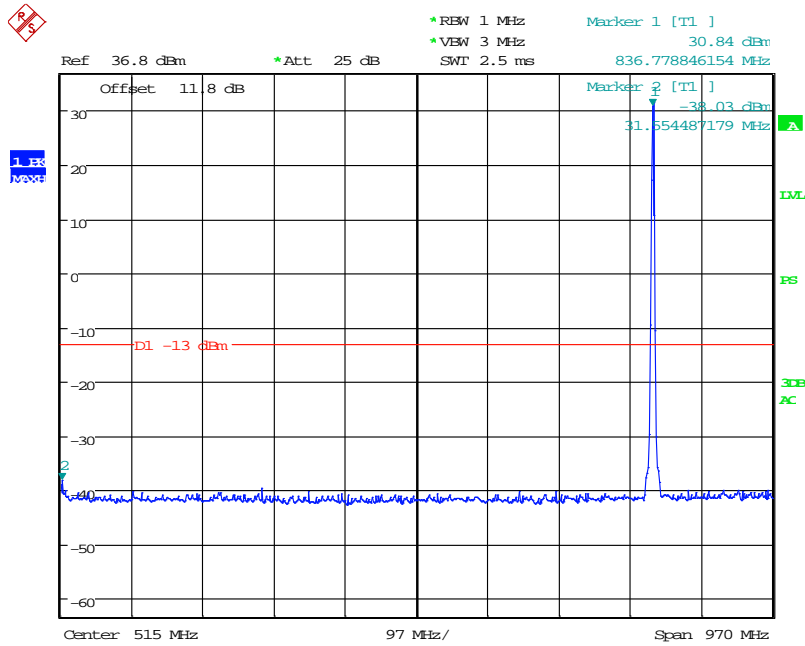

Date: 22.DEC.2015 17:08:34

Note: The strong emission shown in each case is the carrier signal.

8PSK, Mid Channel, 836.6 MHz, 1GHz to 10GHz

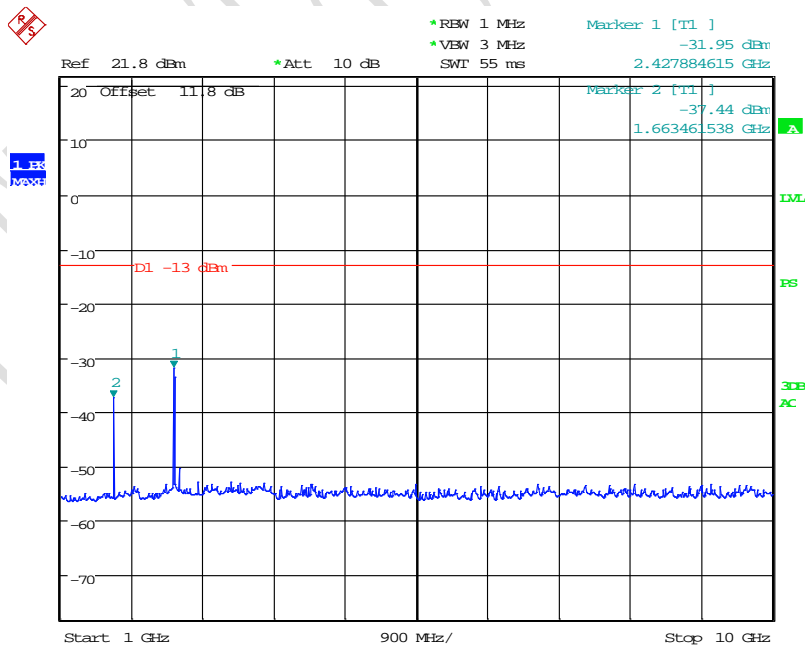

Date: 22.DEC.2015 17:06:28

FCC Parts 2, 22, 24 RSS-Gen, 132, 133
Equipment: WP8548

REPORT NO.: B15W00164-FCC-RF

8PSK, Mid Channel, 836.6 MHz, 10GHz to 20GHz

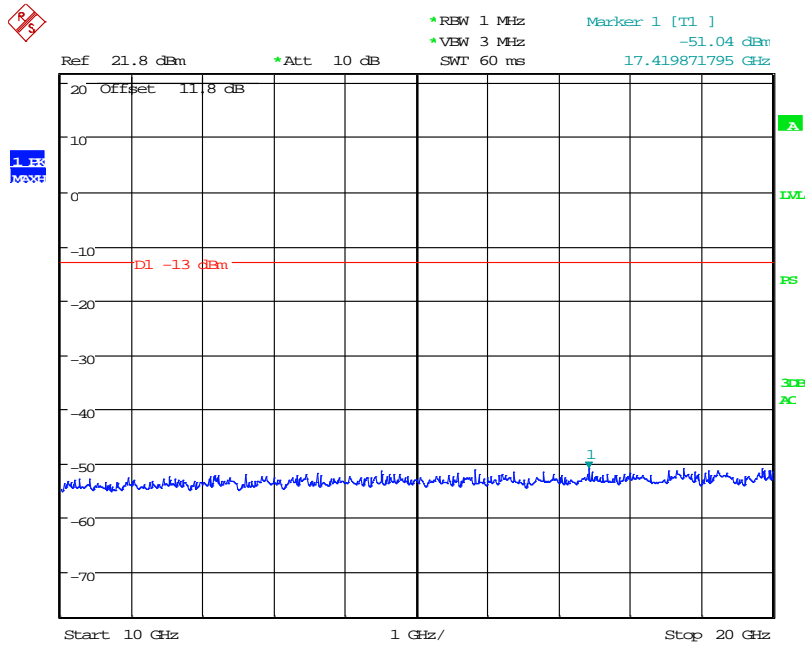

Date: 22.DEC.2015 17:04:24

8PSK, High Channel, 848.8 MHz, 30MHz to 1GHz

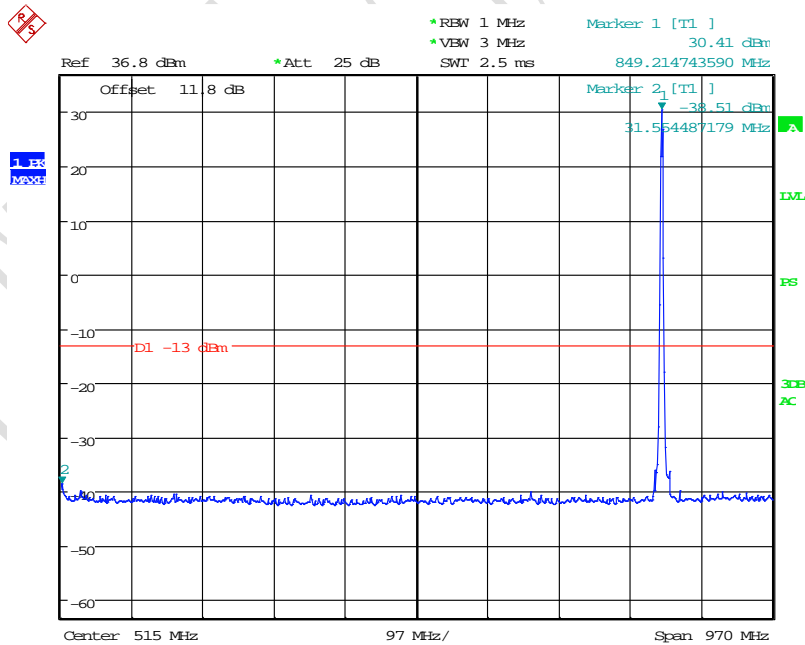

Date: 22.DEC.2015 17:07:57

Note: The strong emission shown in each case is the carrier signal.

FCC Parts 2, 22, 24 RSS-Gen, 132, 133
Equipment: WP8548

REPORT NO.: B15W00164-FCC-RF

8PSK, High Channel, 848.8 MHz, 1GHz to 10GHz

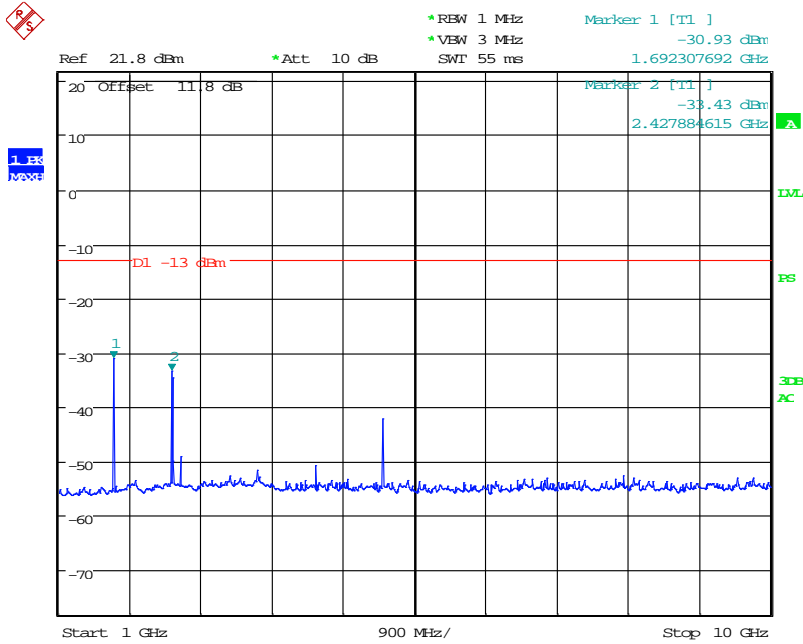

Date: 22.DEC.2015 17:07:04

8PSK, High Channel, 848.8 MHz, 10GHz to 20GHz

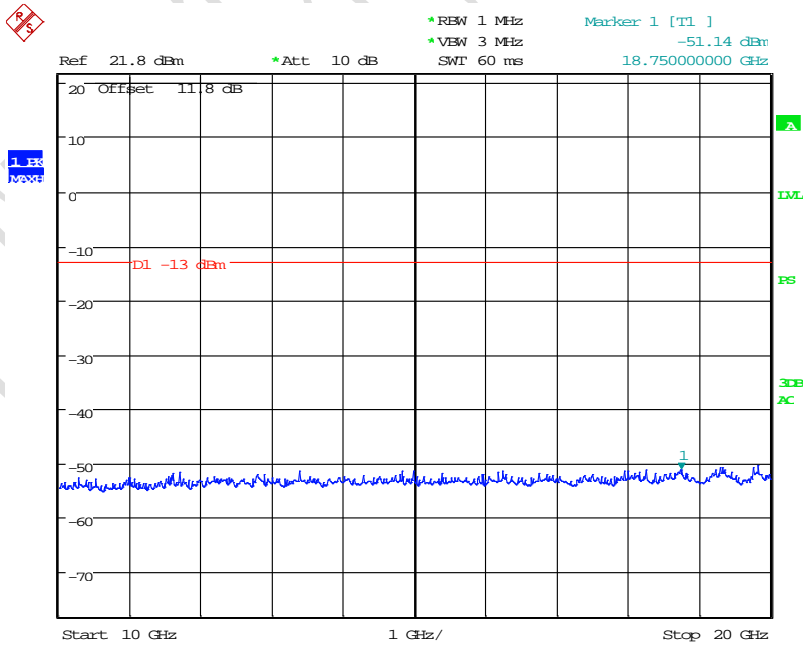

Date: 22.DEC.2015 17:04:02

4.6.2 GSM1900 Conducted Spurious Emission Results

GMSK, Low channel, 1850.2 MHz, 30MHz to 1GHz

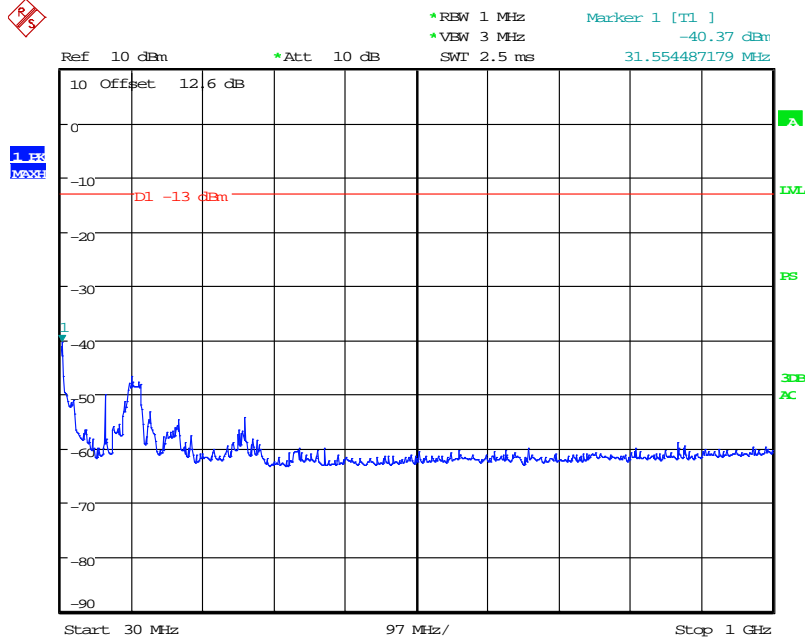

Date: 22.DEC.2015 19:26:47

GMSK, Low channel, 1850.2 MHz, 1GHz to 10GHz

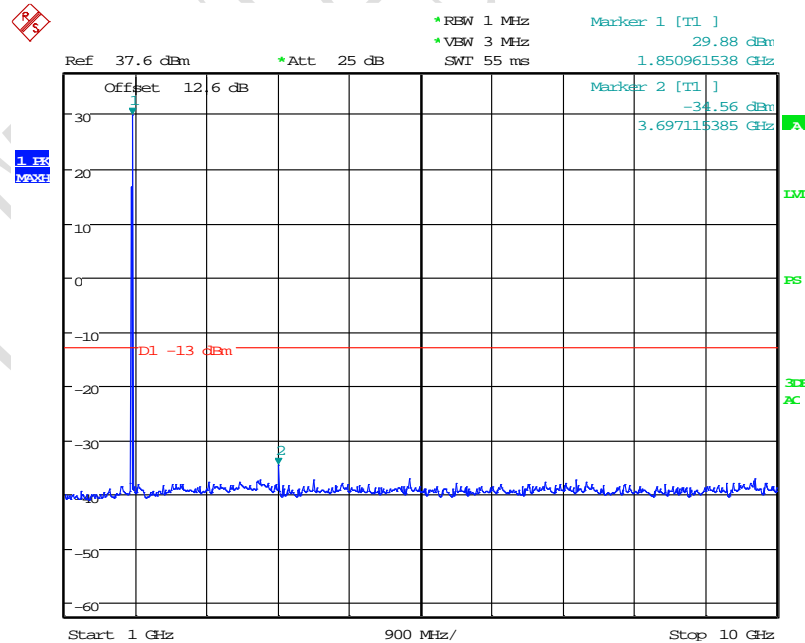

Date: 22.DEC.2015 19:29:10

Note: The strong emission shown is the carrier signal.

FCC Parts 2, 22, 24 RSS-Gen, 132, 133
Equipment: WP8548

REPORT NO.: B15W00164-FCC-RF

GMSK, Low channel, 1850.2 MHz, 10GHz to 20GHz

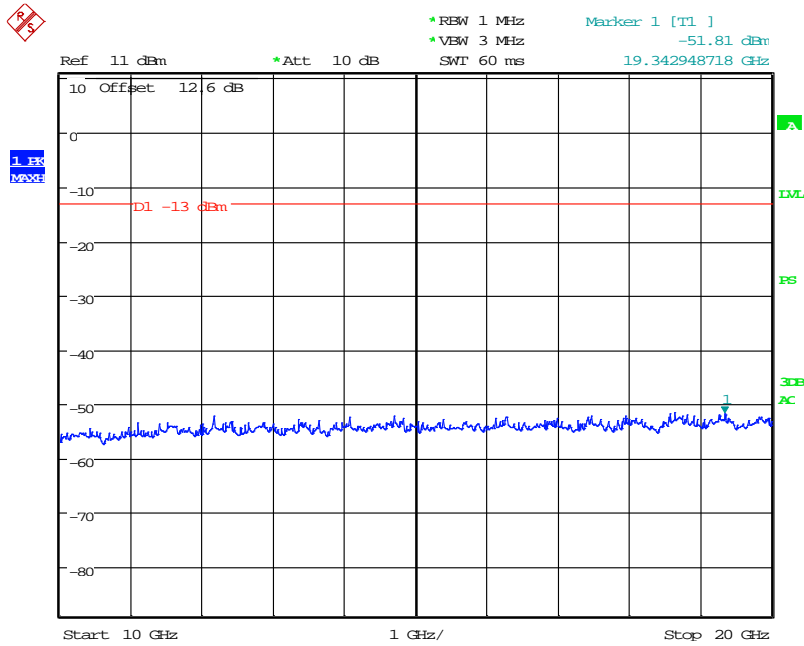

Date: 22.DEC.2015 19:28:41

GMSK, Middle channel, 1880.0 MHz, 30MHz to 1GHz

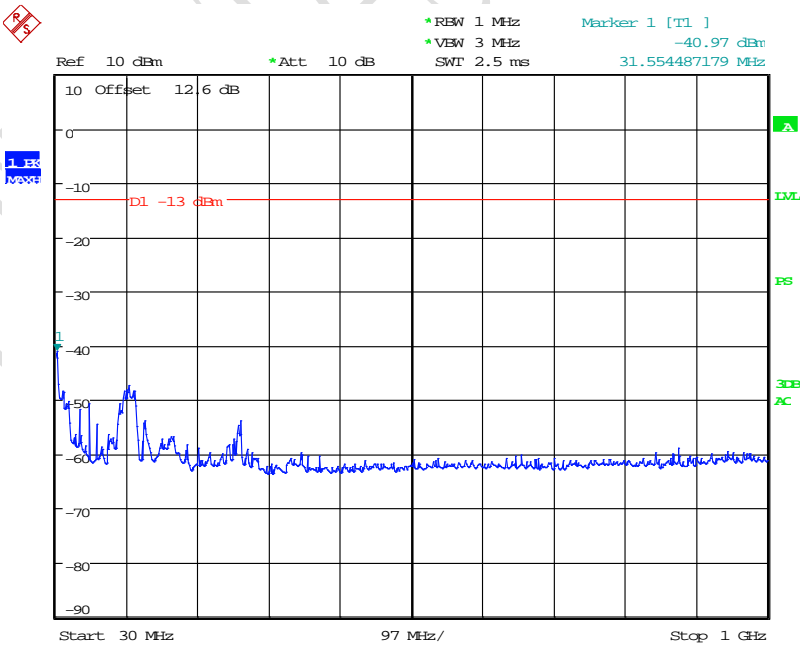

Date: 22.DEC.2015 19:27:01

FCC Parts 2, 22, 24 RSS-Gen, 132, 133
Equipment: WP8548

REPORT NO.: B15W00164-FCC-RF

GMSK, Middle channel, 1880.0 MHz, 1GHz to 10GHz

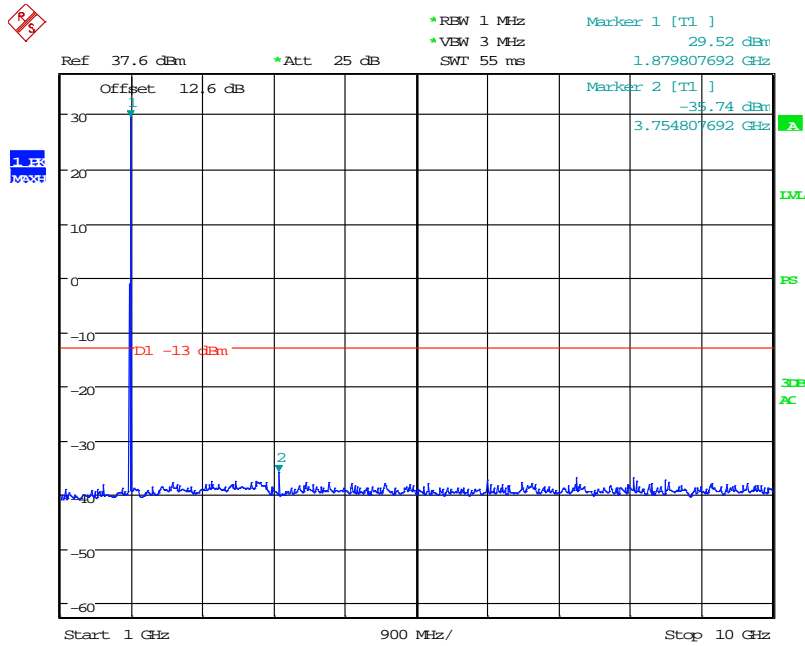

Date: 22.DEC.2015 19:29:32

Note: The strong emission shown is the carrier signal.

GMSK, Middle channel, 1880.0 MHz, 10GHz to 20GHz

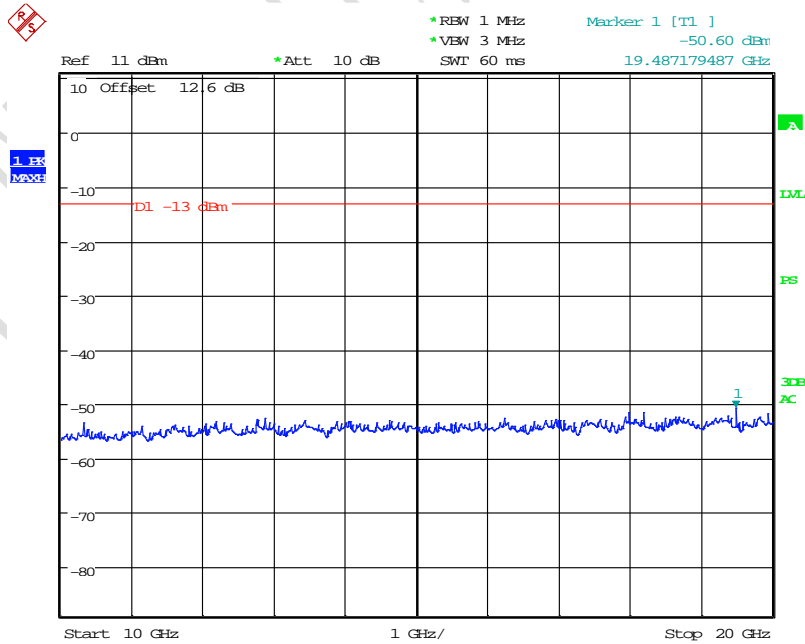

Date: 22.DEC.2015 19:28:22

FCC Parts 2, 22, 24 RSS-Gen, 132, 133
Equipment: WP8548

REPORT NO.: B15W00164-FCC-RF

GMSK, High channel, 1909.8 MHz, 30MHz to 1GHz

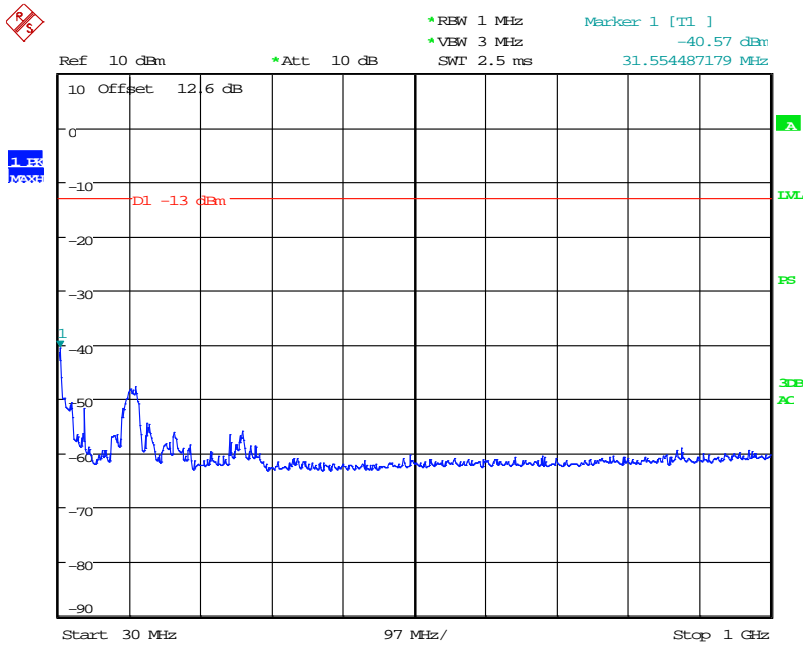

Date: 22.DEC.2015 19:27:38

GMSK, High channel, 1909.8 MHz, 1GHz to 10GHz

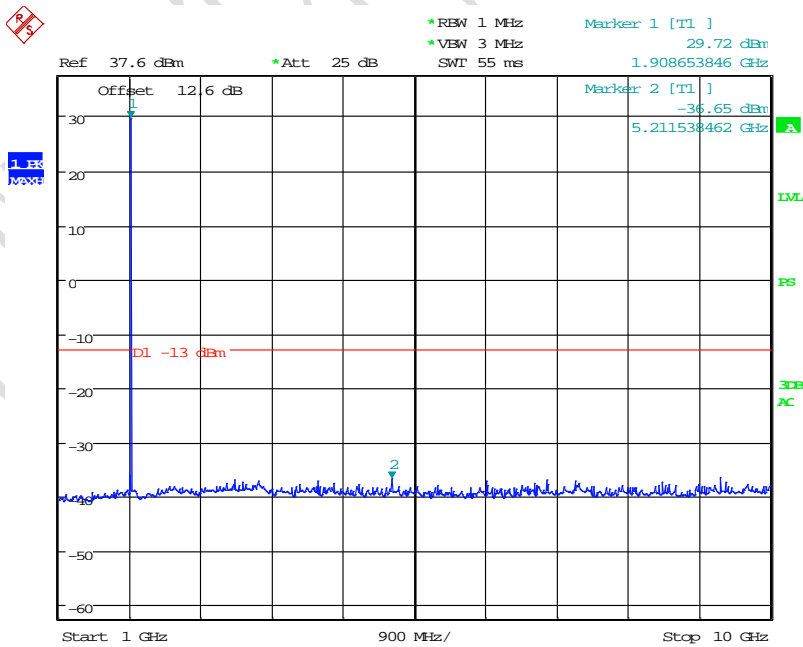

Date: 22.DEC.2015 19:29:57

Note: The strong emission shown is the carrier signal.

FCC Parts 2, 22, 24 RSS-Gen, 132, 133
Equipment: WP8548

REPORT NO.: B15W00164-FCC-RF

GMSK, High channel, 1909.8 MHz, 10GHz to 20GHz

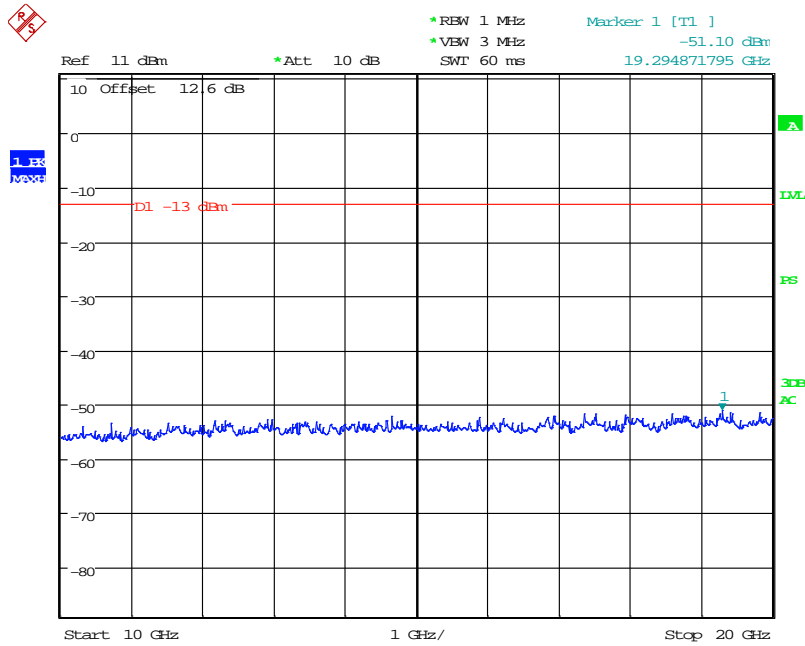

Date: 22.DEC.2015 19:28:07

4.6.3 WCDMA Band II Conducted Spurious Emission Results

QPSK, Low channel, 1850.2 MHz, 30MHz to 1GHz

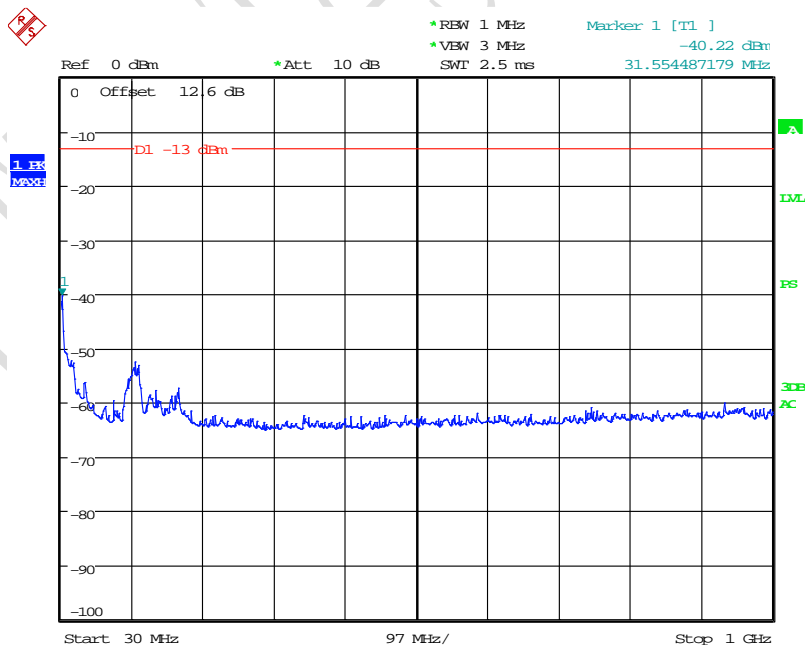

Date: 22.DEC.2015 17:16:53

FCC Parts 2, 22, 24 RSS-Gen, 132, 133
Equipment: WP8548

REPORT NO.: B15W00164-FCC-RF

QPSK, Low channel, 1850.2 MHz, 1GHz to 10GHz

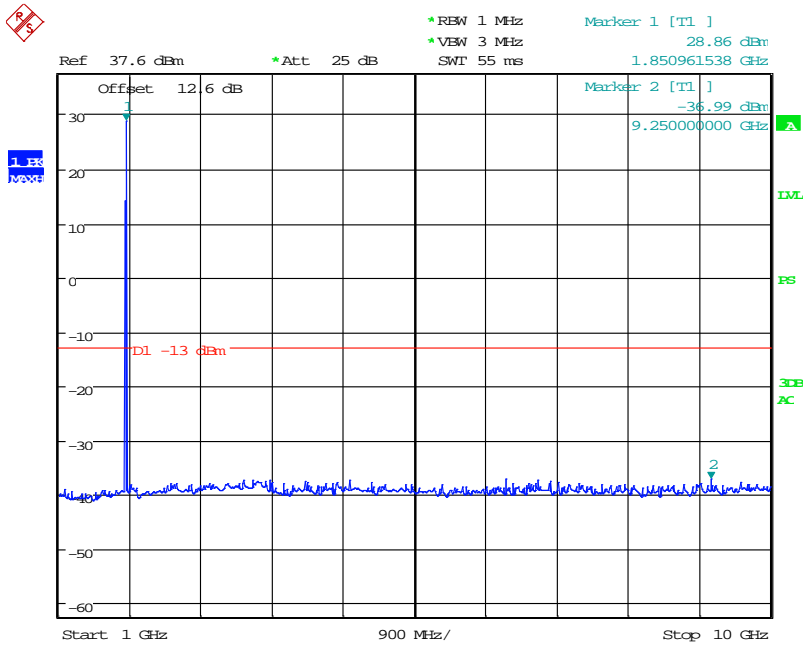

Date: 22.DEC.2015 19:21:44

Note: The strong emission shown is the carrier signal.

QPSK, Low channel, 1850.2 MHz, 10GHz to 20GHz

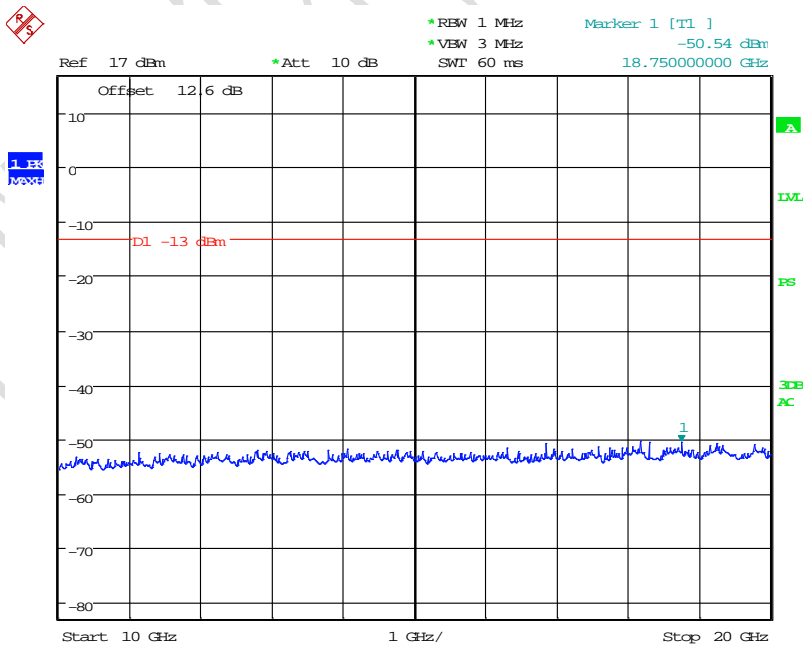

Date: 22.DEC.2015 19:22:19

FCC Parts 2, 22, 24 RSS-Gen, 132, 133
Equipment: WP8548

REPORT NO.: B15W00164-FCC-RF

QPSK, Middle channel, 1880.0 MHz, 30MHz to 1GHz

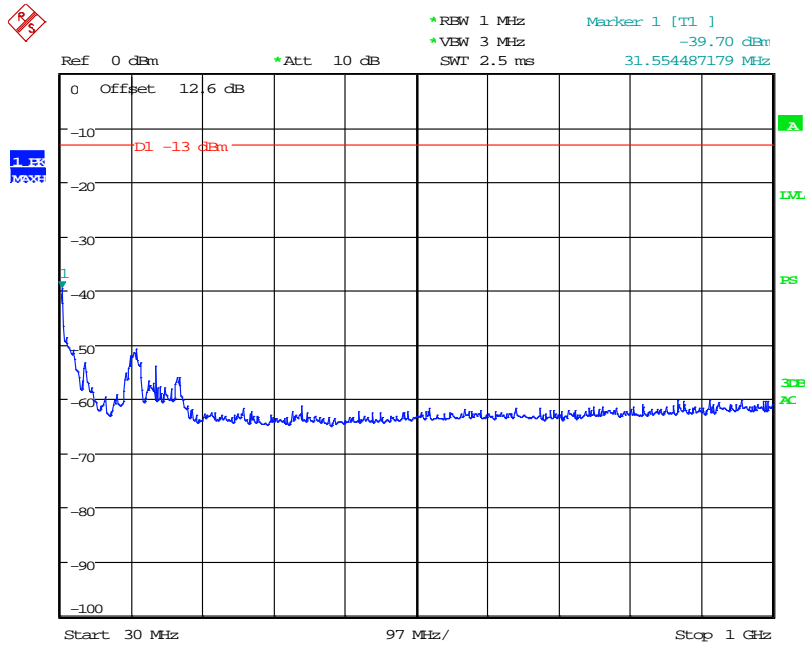

Date: 22.DEC.2015 17:16:15

QPSK, Middle channel, 1880.0 MHz, 1GHz to 10GHz

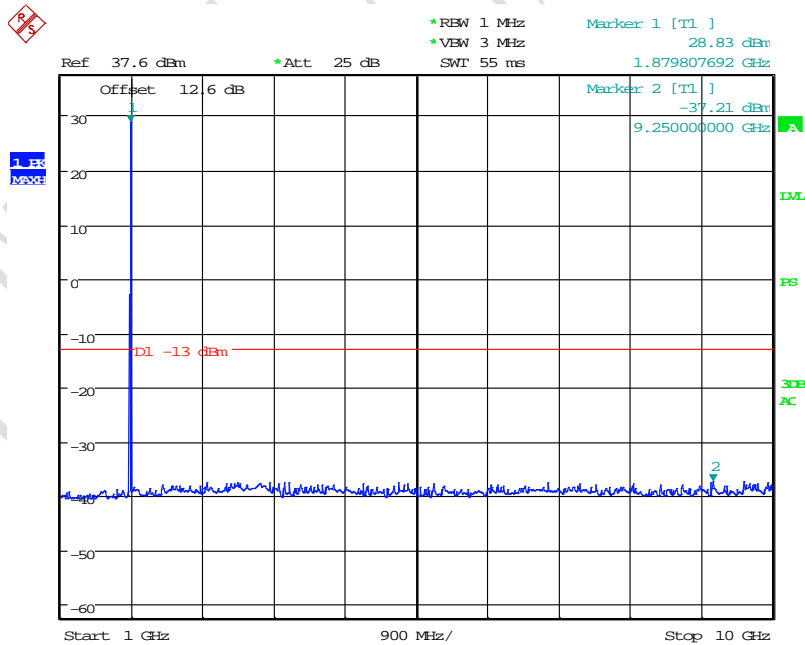

Date: 22.DEC.2015 19:21:03

Note: The strong emission shown is the carrier signal.

FCC Parts 2, 22, 24 RSS-Gen, 132, 133
Equipment: WP8548

REPORT NO.: B15W00164-FCC-RF

QPSK, Middle channel, 1880.0 MHz, 10GHz to 20GHz

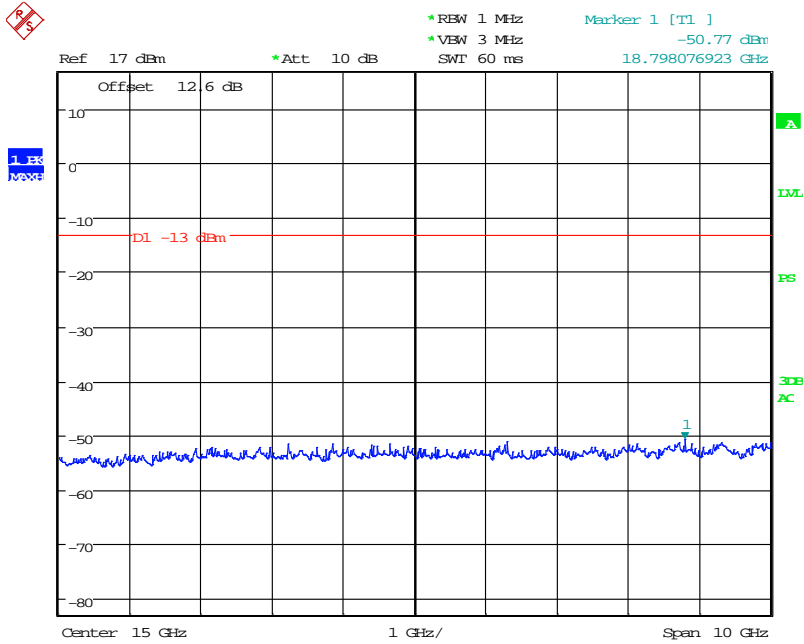

Date: 22.DEC.2015 19:22:41

QPSK, High channel, 1909.8 MHz, 30MHz to 1GHz

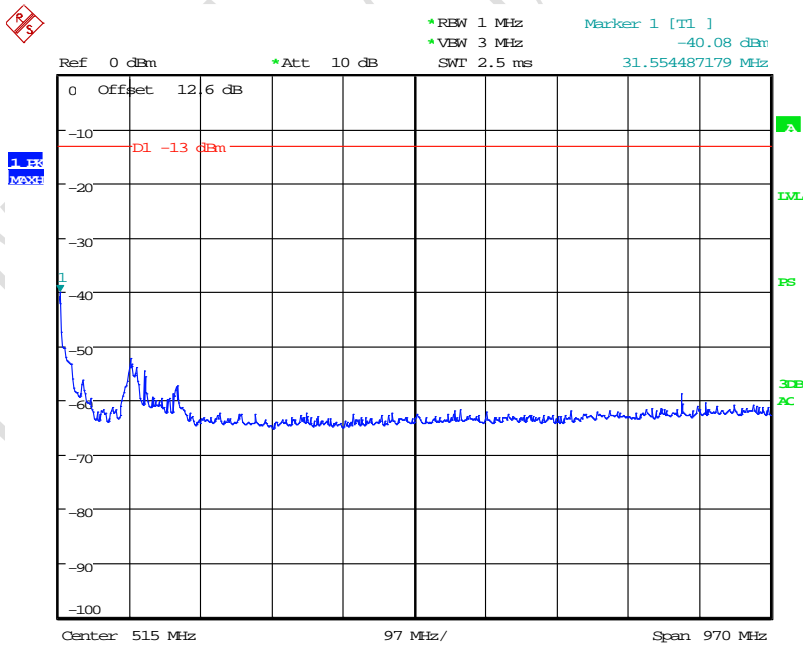

Date: 22.DEC.2015 17:17:14

FCC Parts 2, 22, 24 RSS-Gen, 132, 133
Equipment: WP8548

REPORT NO.: B15W00164-FCC-RF

QPSK, High channel, 1909.8 MHz, 1GHz to 10GHz

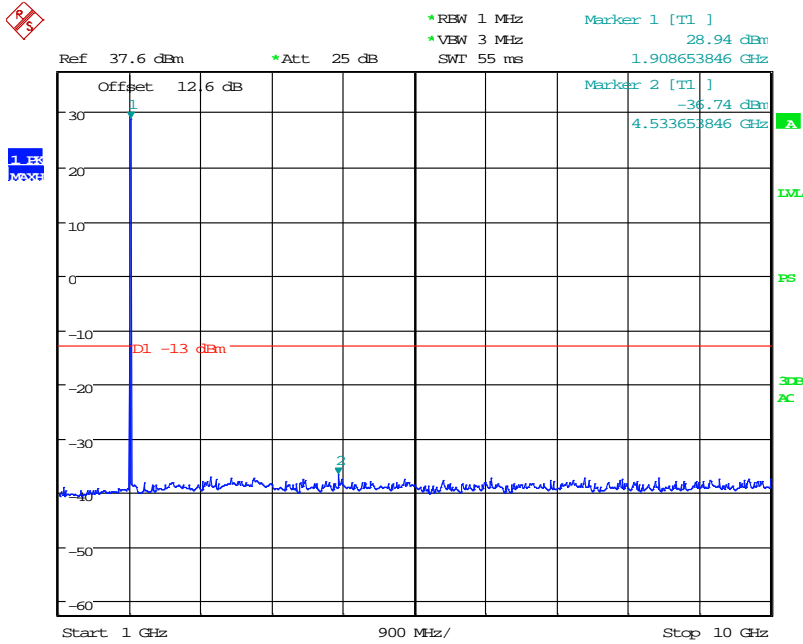

Date: 22.DEC.2015 19:20:32

Note: The strong emission shown is the carrier signal

QPSK, High channel, 1909.8 MHz, 10GHz to 20GHz

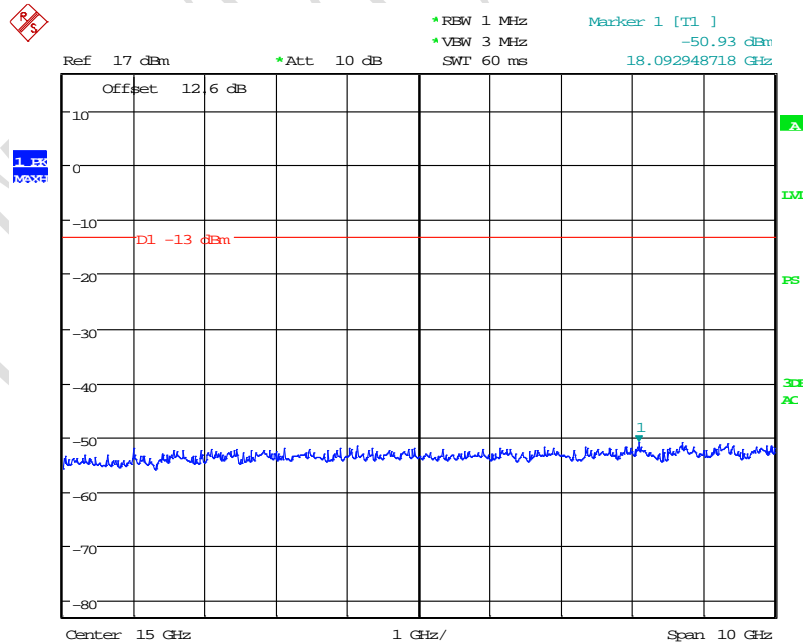

Date: 22.DEC.2015 19:22:59

4.6.4 WCDMA Band V Conducted Spurious Emission Results

QPSK, Low channel, 826.4 MHz, 30MHz to 1GHz

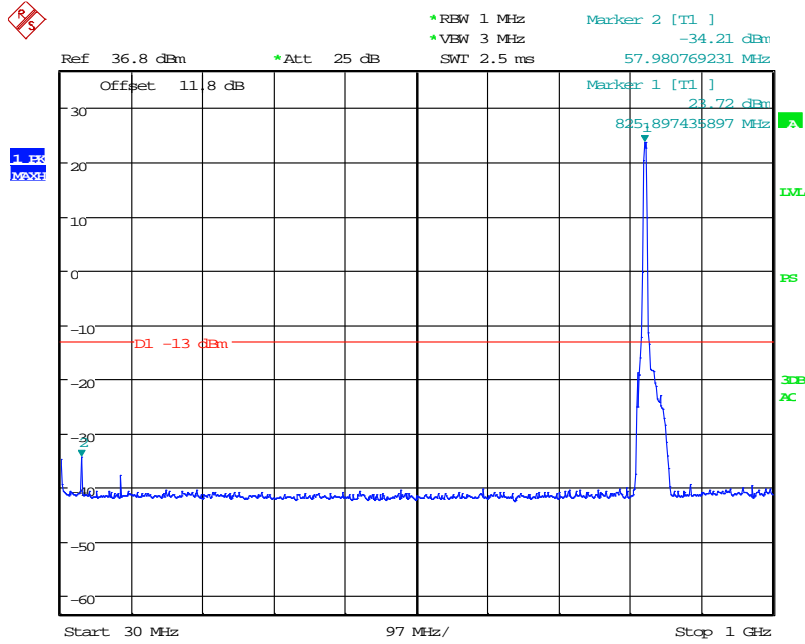

Date: 22.DEC.2015 19:42:14

Note: The strong emission shown in each case is the carrier signal.

FCC Parts 2, 22, 24 RSS-Gen, 132, 133
Equipment: WP8548

REPORT NO.: B15W00164-FCC-RF

QPSK, Low channel, 826.4 MHz, 1GHz to 10GHz

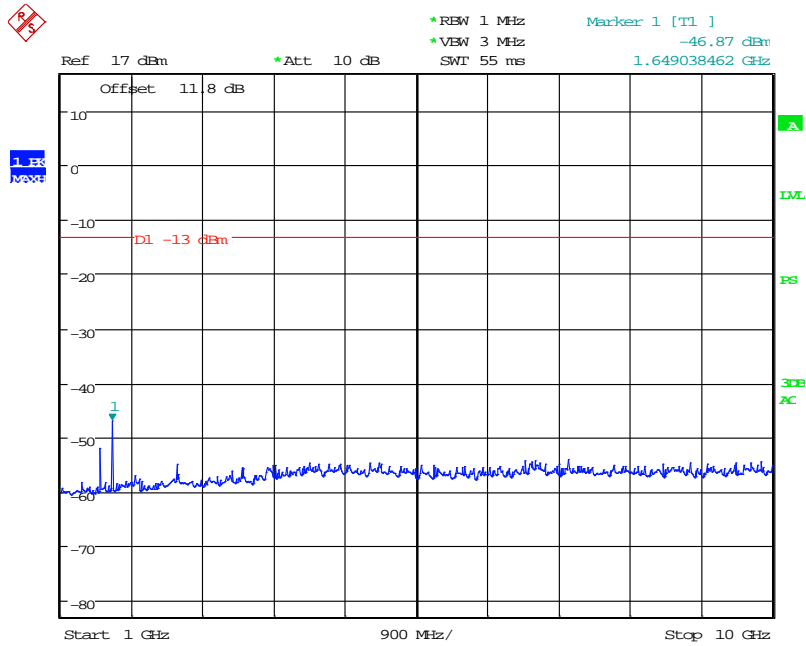

Date: 22.DEC.2015 19:44:28

QPSK, Low channel, 826.4 MHz, 10GHz to 20GHz

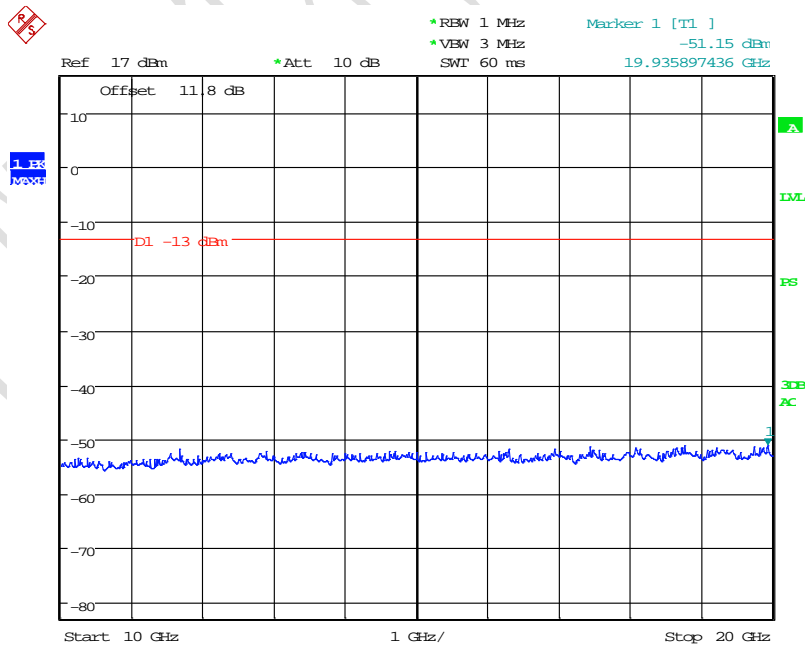

Date: 22.DEC.2015 19:45:27

FCC Parts 2, 22, 24 RSS-Gen, 132, 133
Equipment: WP8548

REPORT NO.: B15W00164-FCC-RF

QPSK, Middle channel, 836.4 MHz, 30MHz to 1GHz

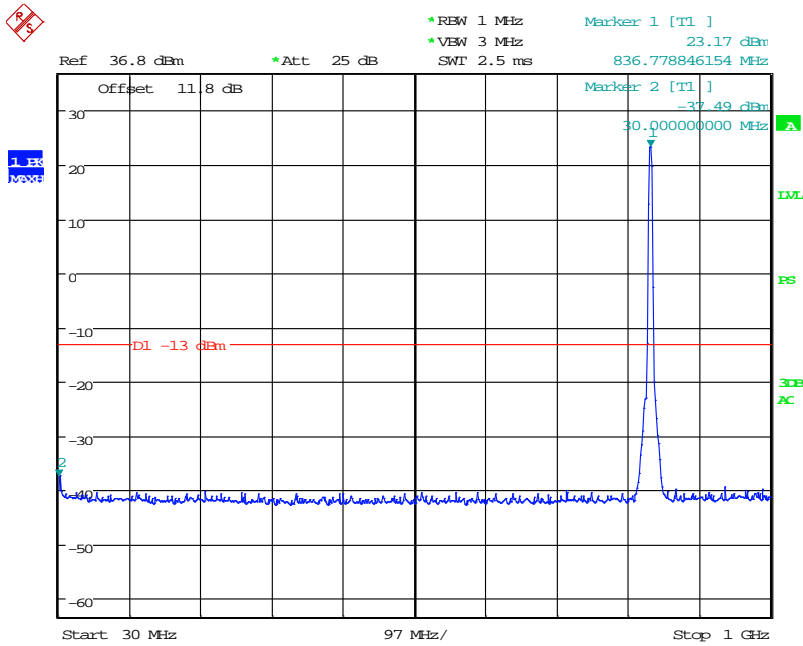

Date: 22.DEC.2015 19:42:52

Note: The strong emission shown in each case is the carrier signal.

QPSK, Middle channel, 836.4 MHz, 1GHz to 10GHz

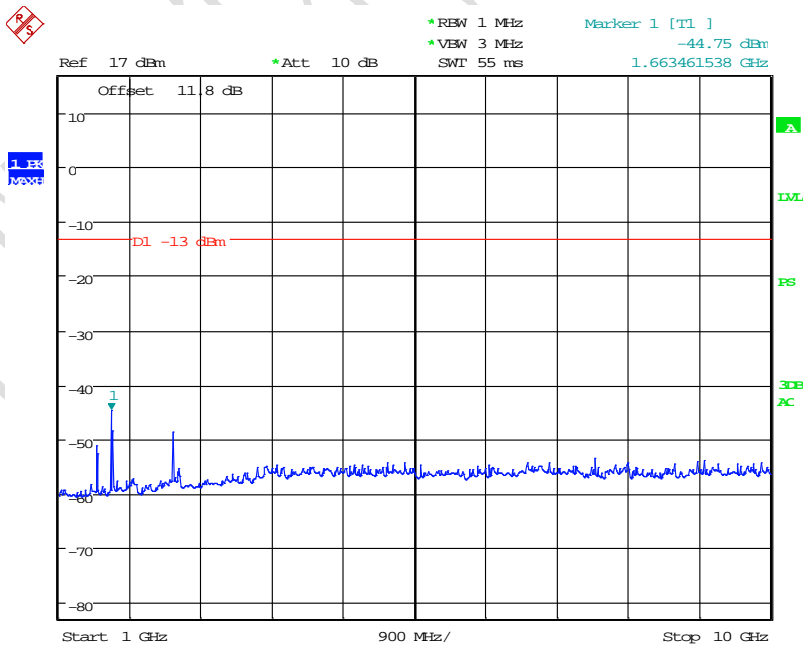

Date: 22.DEC.2015 19:44:07

FCC Parts 2, 22, 24 RSS-Gen, 132, 133
Equipment: WP8548

REPORT NO.: B15W00164-FCC-RF

QPSK, Middle channel, 836.4 MHz, 10GHz to 20GHz

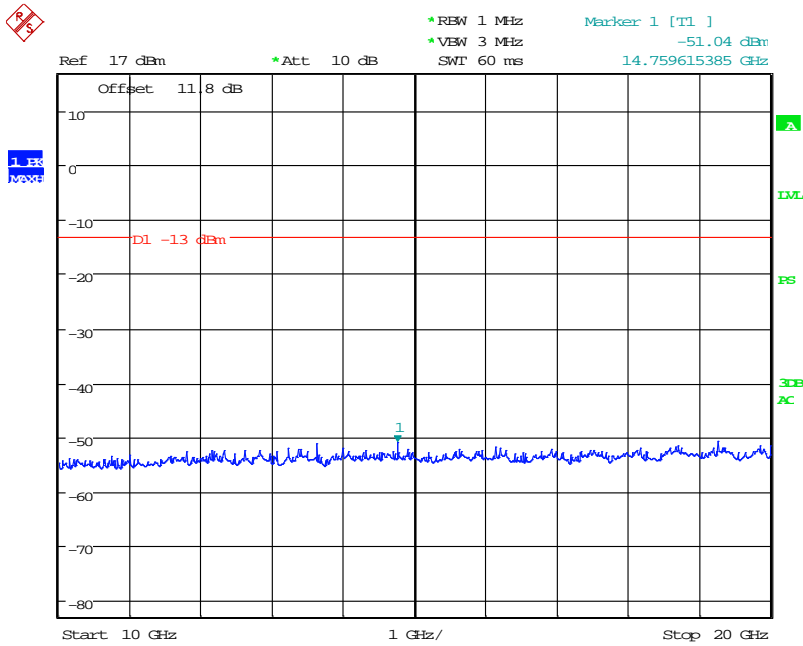

Date: 22.DEC.2015 19:46:04

QPSK, High Channel, 846.6 MHz, 30MHz to 1GHz

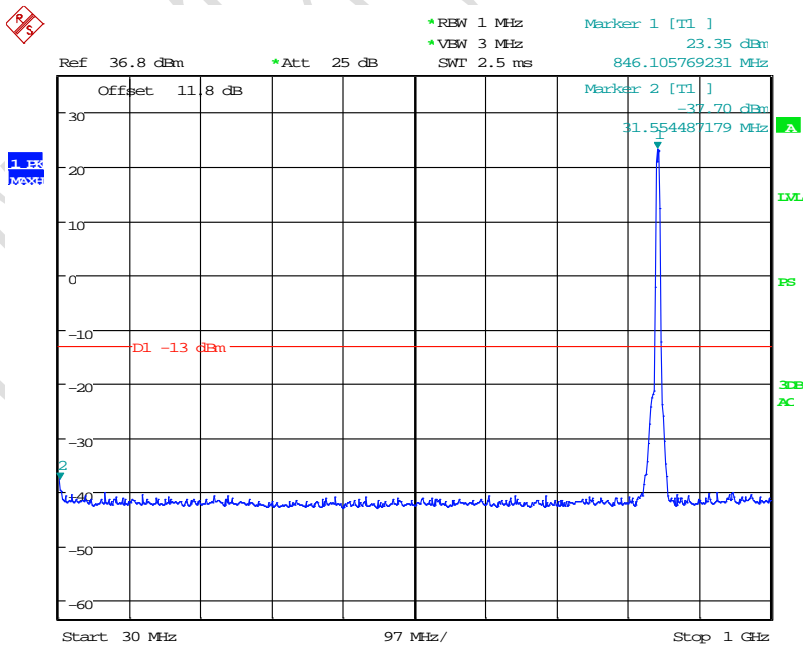

Date: 22.DEC.2015 19:43:16

Note: The strong emission shown in each case is the carrier signal.

FCC Parts 2, 22, 24 RSS-Gen, 132, 133
Equipment: WP8548

REPORT NO.: B15W00164-FCC-RF

QPSK, High Channel, 846.6 MHz, 1GHz to 10GHz

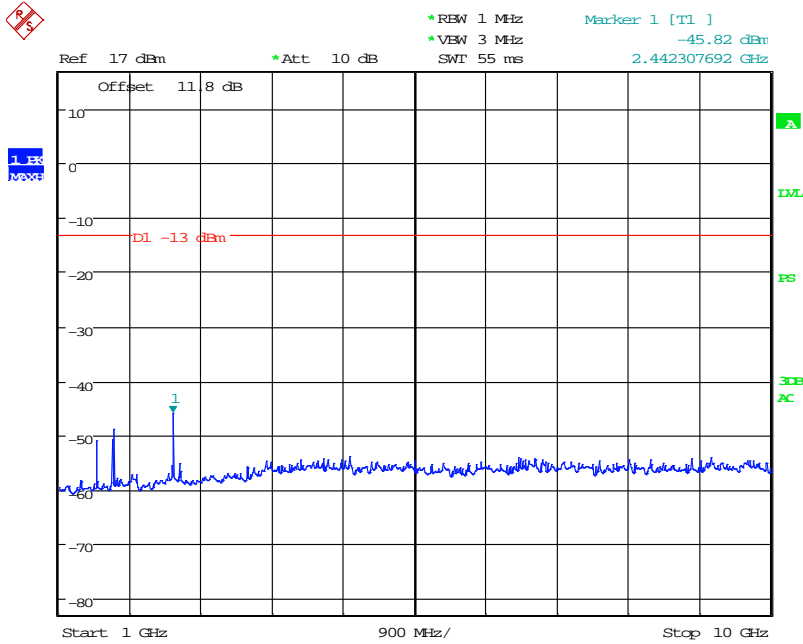

Date: 22.DEC.2015 19:43:46

QPSK, High Channel, 846.6 MHz, 10GHz to 20GHz

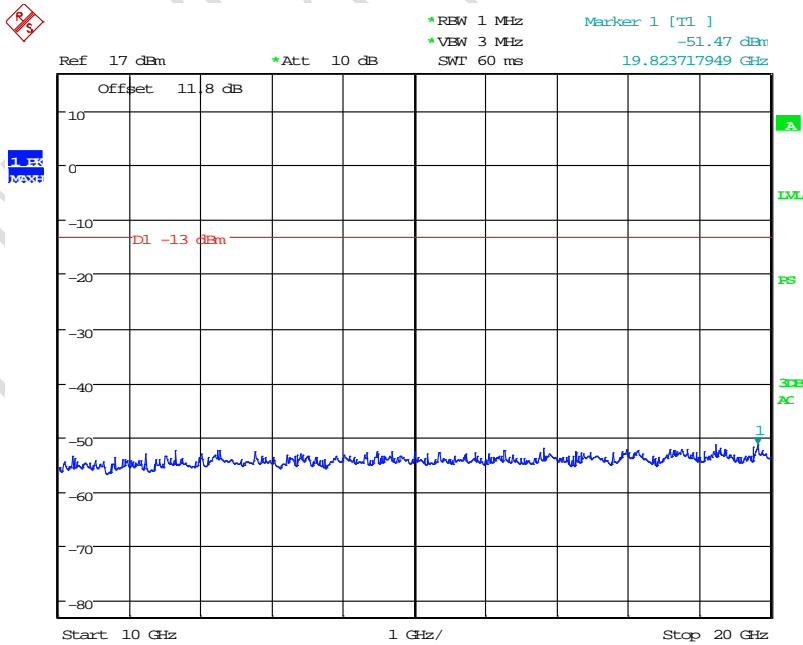

Date: 22.DEC.2015 19:46:27

4.7 Band Edge

Specifications:	FCC Part 2.1051, 24.238, 2.1053, 22.917
Date of Tests	2015-12-22-2016-1-12
DUT Serial Number	S2/3: 359377060005203
Test conditions:	Ambient Temperature: 15°C-35°C Relative Humidity: 30%-60% Air pressure: 86-106kPa
Operation Mode	TX on, channel 128, 251 and 512, 810 for GSM/GPRS/EGPRS mode, channel 4132, 4233 and 9262, 9538 for WCDMA/HSUPA/HSDPA mode.
Test Results:	Pass

Limit Level Construction:

According to Part 24.238 (a), i.e., Out of band emissions. The power of any emission outside of the authorized operating frequency ranges must be attenuated below the transmitting power (P) by a factor of at least $43 + 10 \log(P)$ dB, so the limit level is:
 $P(\text{dBm}) - (43 + 10 \log(P)) \text{ dB} = -13\text{dBm}$

Limits for Radiated spurious emissions

Frequency range	Limit Level
Band edge	-13dBm

Test Setup:

During the test, the EUT was controlled via the Wireless Communications Test Set to ensure max power transmission and proper modulation and measured by spectrum analyzer.

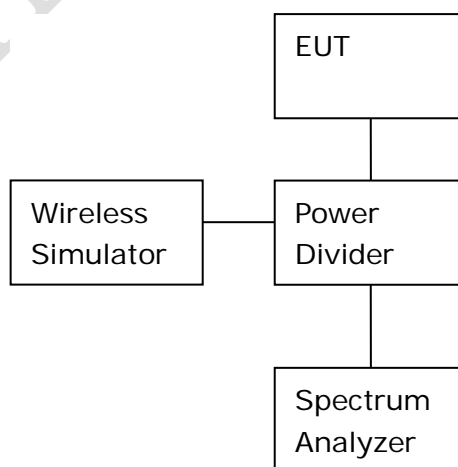

Test Method

- 1) The EUT was coupled to the EMI test receiver analyzer mode and the base station simulator through a power divider. The lost of the cables the test system is calibrated to correct the readings.
- 2) The spectrum analyzer was set to Maxpeak Detector function and Maximum hold mode.
- 3) The resolution bandwidth of the spectrum analyzer was a little greater than 1% of the 26dB emission bandwidth.

Note: --

Test Results:

Graphical results :

4.7.1 GSM850 Band Edge Results

GSMK; Cellular low channel, below 824 MHz

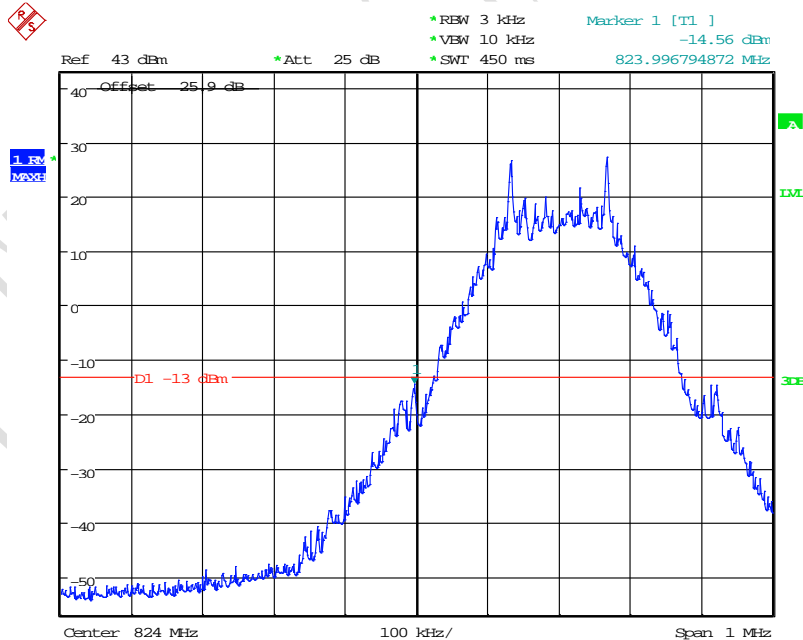

Date: 7.JAN.2016 18:04:39

FCC Parts 2, 22, 24 RSS-Gen, 132, 133
Equipment: WP8548

REPORT NO.: B15W00164-FCC-RF

GMSK; Cellular high channel, above 849 MHz

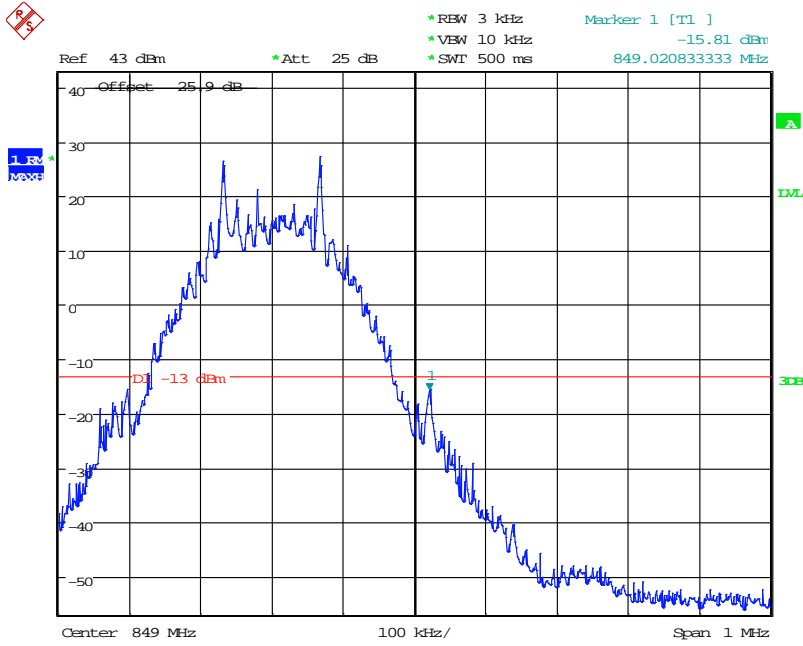

Date: 7.JAN.2016 18:11:24

8PSK; Cellular low channel, below 824 MHz

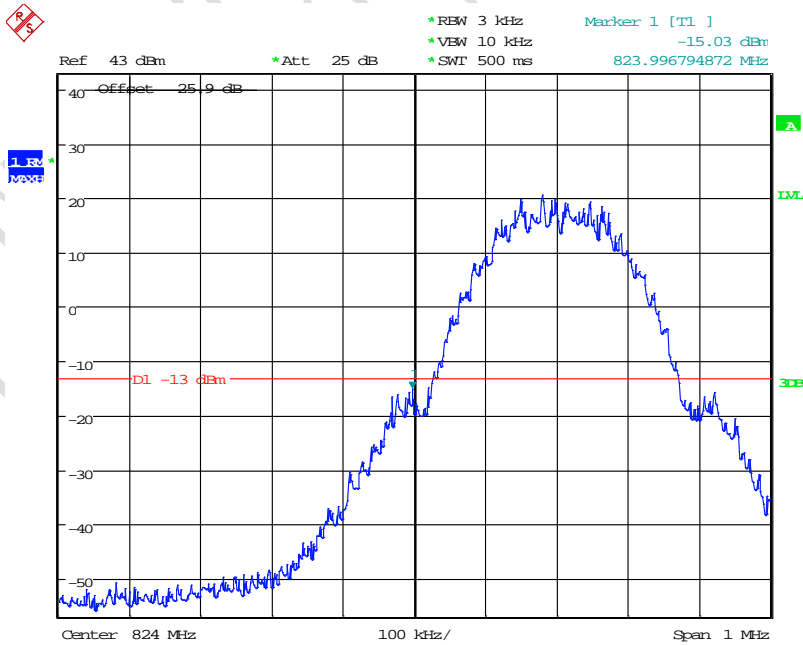

Date: 7.JAN.2016 18:08:36

FCC Parts 2, 22, 24 RSS-Gen, 132, 133
Equipment: WP8548

REPORT NO.: B15W00164-FCC-RF

8PSK; Cellular high channel, above 849 MHz

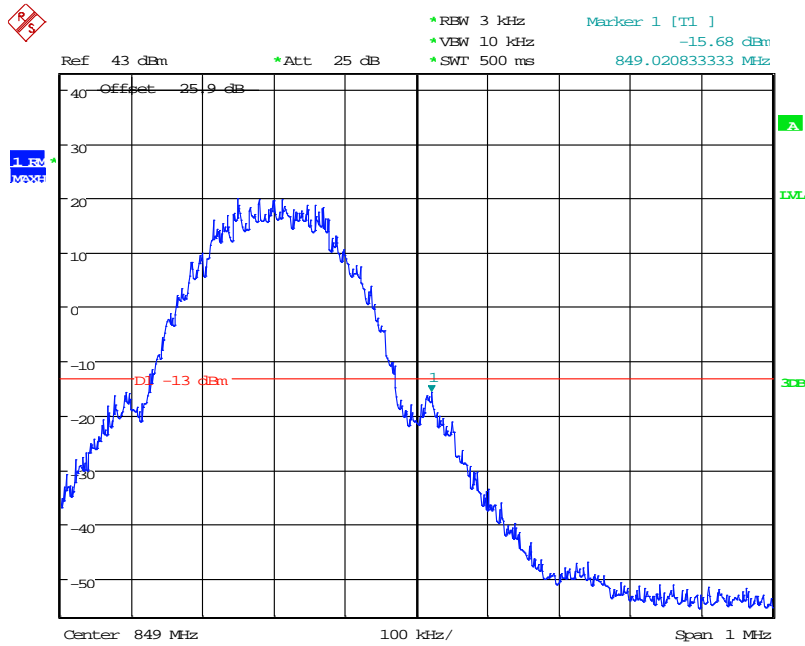

Date: 7.JAN.2016 18:10:00

4.7.2 GSM1900 Band Edge Results

GMSK; PCS low channel, below 1850 MHz

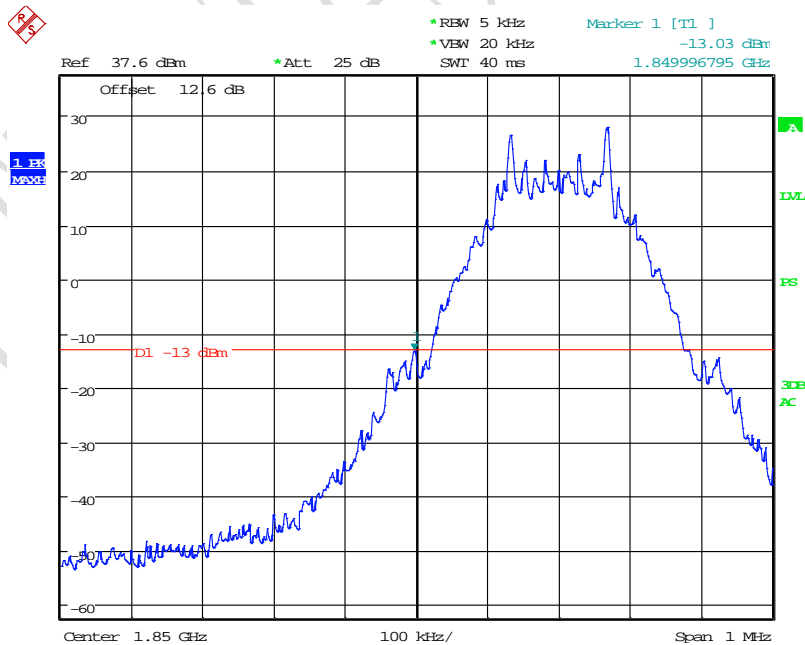

Date: 23.DEC.2015 10:28:55

GMSK; PCS high channel, above 1910 MHz

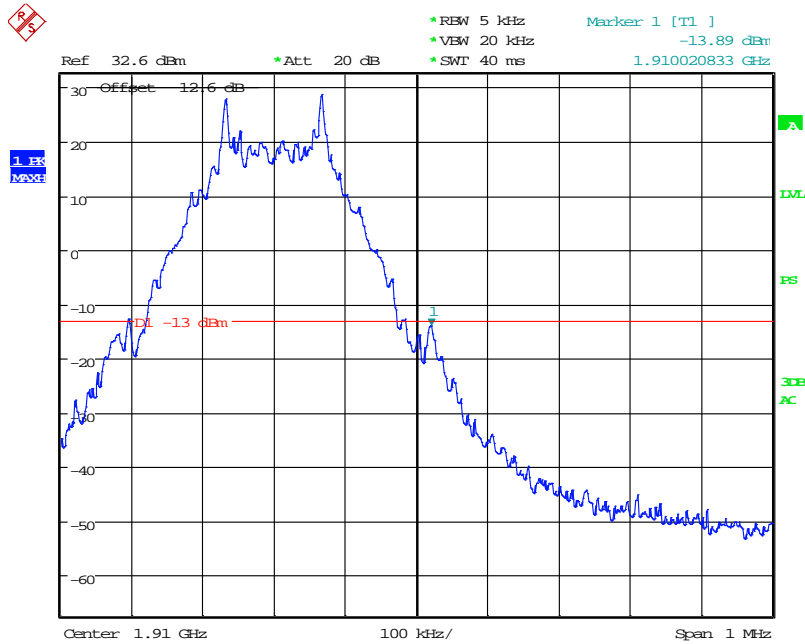

Date: 22.DEC.2015 20:18:15

8PSK; PCS low channel, below 1850 MHz

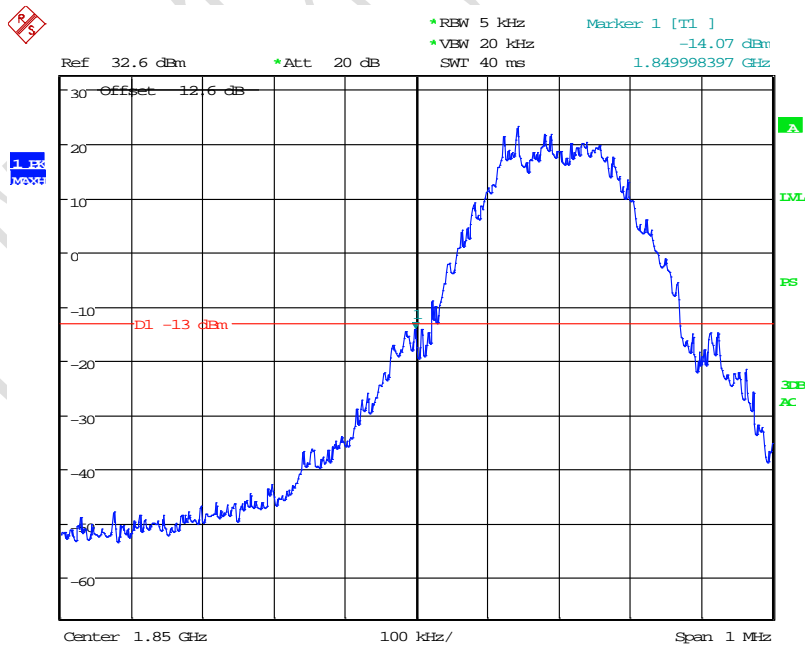

Date: 22.DEC.2015 20:15:04

FCC Parts 2, 22, 24 RSS-Gen, 132, 133
Equipment: WP8548

REPORT NO.: B15W00164-FCC-RF

8PSK; PCS high channel, above 1910 MHz

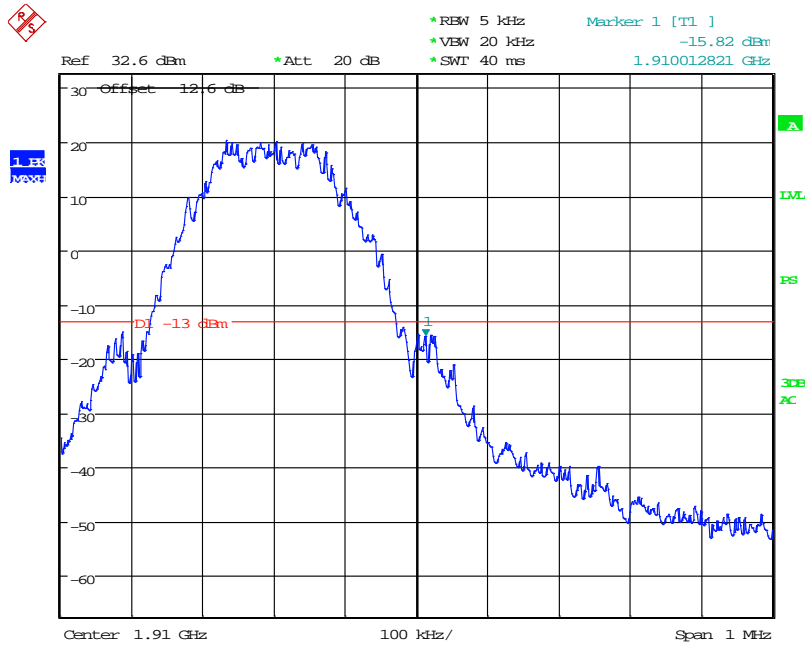

Date: 22.DEC.2015 20:19:01

4.7.3 WCDMA B5 Band Edge Results

QPSK; Cellular low channel, below 824 MHz

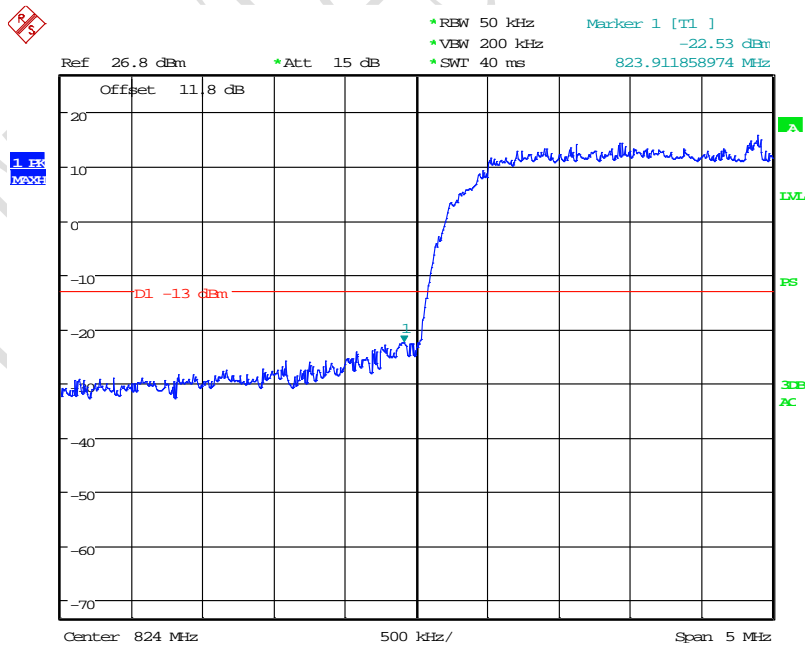

Date: 22.DEC.2015 20:27:41

FCC Parts 2, 22, 24 RSS-Gen, 132, 133
Equipment: WP8548

REPORT NO.: B15W00164-FCC-RF

QPSK; Cellular high channel, above 849 MHz

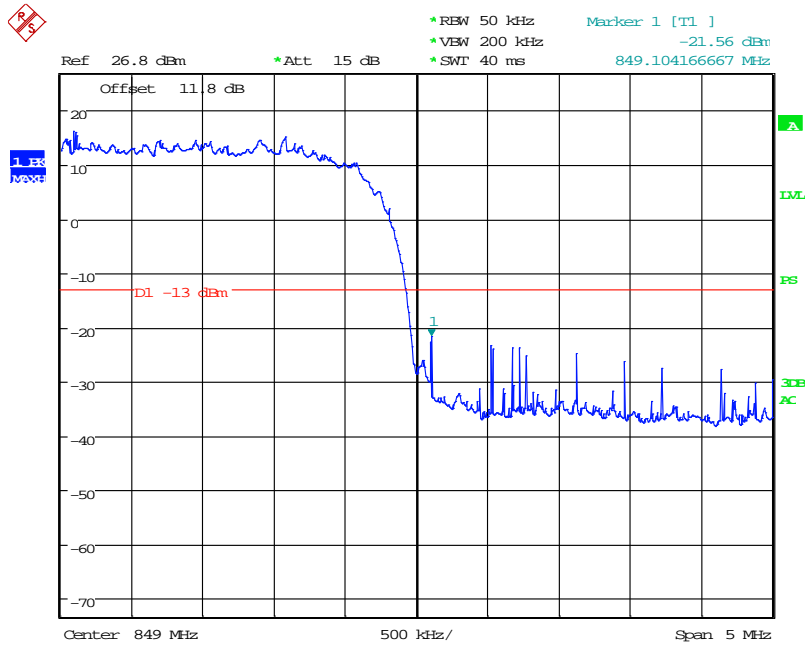

Date: 22.DEC.2015 20:28:17

4.7.4 WCDMA B2 Band Edge Results

QPSK; PCS low channel, below 1850 MHz

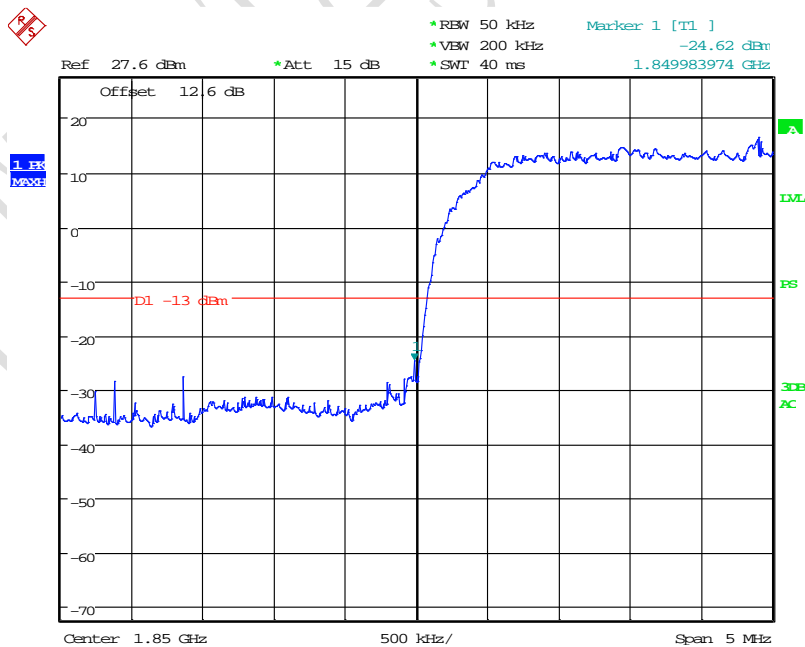

Date: 22.DEC.2015 20:23:57

QPSK; PCS high channel, above 1910 MHz

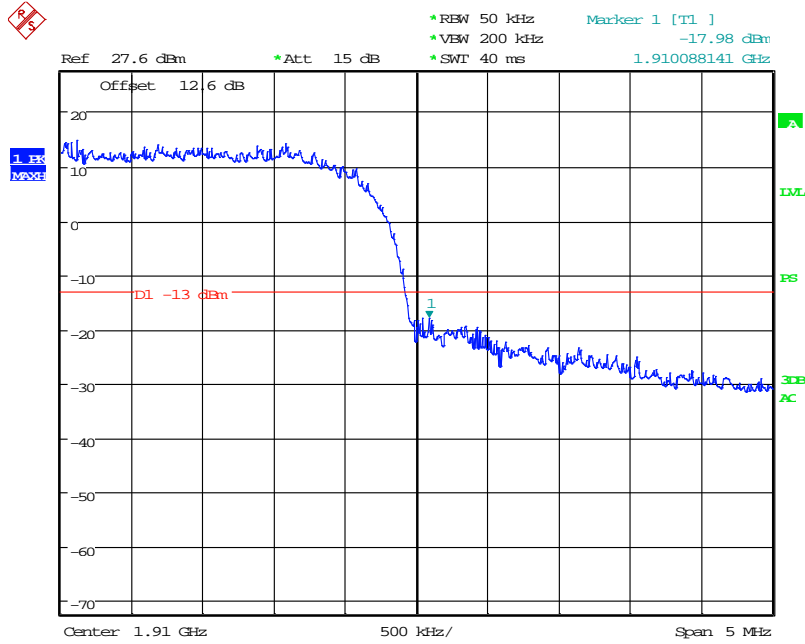

Date: 22.DEC.2015 20:23:23

CITEL TEST

Annex A External Photos

See the document "WP8548- External Photos".

Annex B Internal Photos

See the document "WP8548-Internal Photos".

ANNEX C Deviations from Prescribed Test Methods

No deviation from Prescribed Test Methods.

————— **The End of this Report** —————