

- 1 Unattended POS
- 2 Data Cable

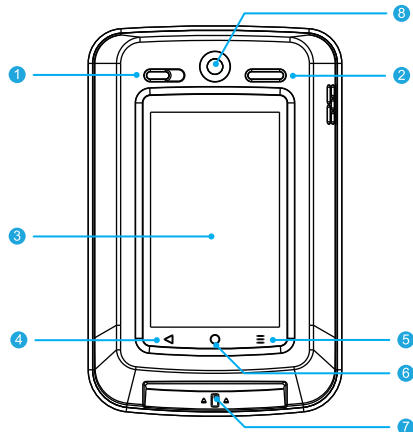

- 1 Power Indicator
- 2 4 LED Indicators
- 3 4.0" Capacitive Touch Screen
- 4 Return Button
- 5 Menu Button
- 6 Home Button
- 7 IC Card Reader
- 8 Camera

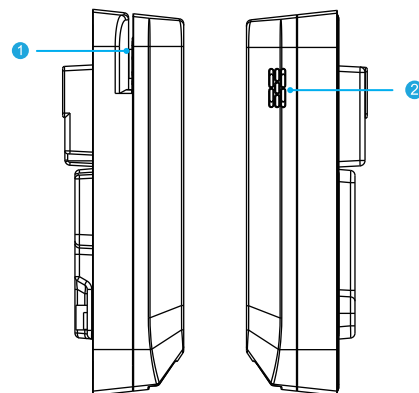

- 1 Magnetic Card Reader
- 2 Speaker

WIZARPOS User Manual UPT

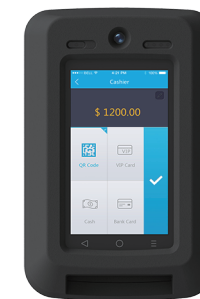

www.wizarpos.com

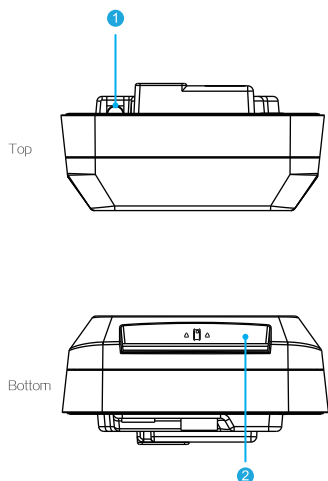

- 1 12-24V DC Jack
- 2 IC Card Reader

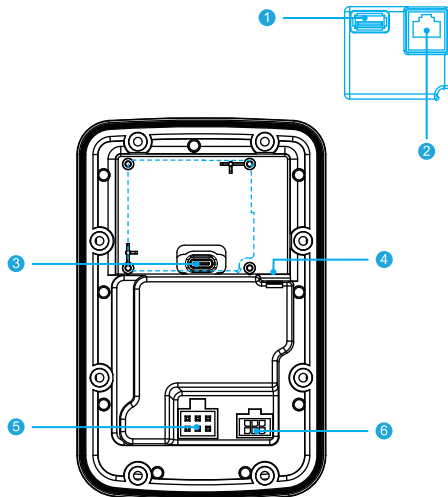

- 1 USB Type A (optional)
- 2 Ethernet (optional)
- 3 Type-C
- 4 12-24V DC Jack
- 5 MDB Master / RS232
- 6 MDB Slave / RS232

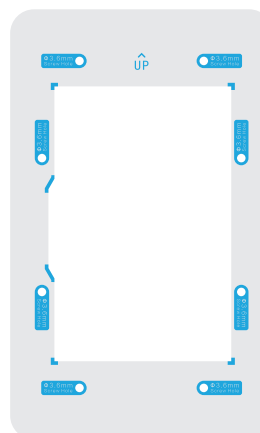

- 1 Punch template sticker

Thank you for using the product of WizarPOS!

Intelligent + Security



Certification in progress ...

1 Before use

- a) Please check if the configuration is consistent with the requirements;
- b) Please check whether the accessories are complete, including data cables and punch templates;

2 Power on and off

- a) This product supports 12~24V DC or MDB power supply;
- b) After the product is powered on, it will automatically turn on and is always running;
- c) When the product needs to be restarted, please cut off the power first and then power on again;

3 System setup

Click the "setup" icon on the desktop to setup the system.
You can set up the POS as needed.

4 Payment operation

Please follow the instructions of your payment App provider.

5 Bank card operation

- a) Please insert the IC card face up into the IC card reader.
- b) Swipe the magnetic stripe card with magnetic stripe facing to screen, you can bi-directionally swipe the card.
- c) Tap the contactless card close to the contactless quickly area to read the card.

Installation Guide

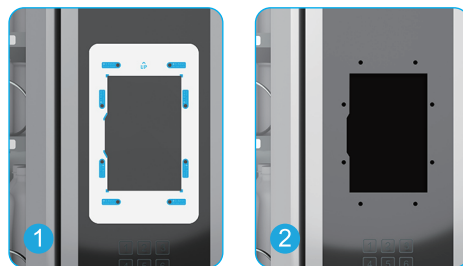

Attach the template with mounting holes to the surface of the vending machine and mark the holes.

Punch holes according to the marks.

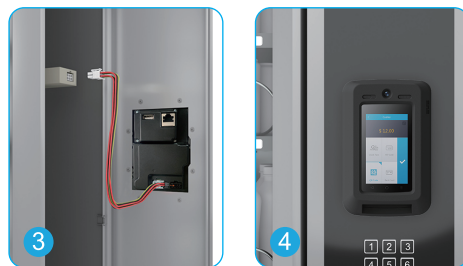

Fix the Q3V with screws and connect the MDB cable to the control board of the vending machine.

Power on and run after installation.

Specification	Detailed Description
Software Platform	Secure Android, Based on Android 7.1
Processor	Qualcomm + Secure Chip
Memory	1GB RAM, 8GB Flash or 2GB RAM ,16GB Flash
Display	4" multi-touch color LCD panel (480 x 800 mm)
Scanner	1D & 2D barcode scanning
Security Certification	PCI PTS 5.x
Contactless Card	ISO14443 Type A & B, Mifare, Contactless EMV Level 1, Mastercard Paypass, Paywave, expresspay and D-PAS.
IC Card	ISO7816, EMV Level 1 & Level 2 (optional)
MSR	ISO7811, Track 1/2/3, Bi-direction
Communication	GSM, WCDMA, FDD-LTE, TDD-LTE, Wi-Fi, BT4.0
Audio	Built-in microphone, speaker
USB	USB Type-C OTG, USB 2.0 HS compliant
Power	24V DC in / MDB power supply
Dimensions	157x 102 x 38 mm (61.8 x 40 x 15 inches)
Weight	400 g (0.88 lb)

All features and specifications are subject to change without notice.
Contact wizarPOS website for more details.
www.wizarpos.com

Environment

- Operating Temperature
0°C-45°C (32°F to 113°F)
- Operating Humidity
10%-93% No condensation
- Storage Temperature
-20°C-60°C (-4°F to 140°F)
- Storage Humidity
10%-93% No condensation

Attention

- ◆ Do NOT refit the POS, that is illegal to privately refit financial POS and the warranty is also invalid.
- ◆ User shall bear all the risks of installation and usage of third party Apps.
- ◆ The system will become slow due to too many APPs installed.
- ◆ Please use dry cloth to clean the POS, Do NOT use chemical.
- ◆ Do NOT use sharp and hard objects to touch the screen.
- ◆ Do NOT throw the POS, as common household garbage.
Please support recycle according to local environment rules.

Product warranty policy

WizarPOS provide after-sales service according to relative laws.
Please read the following warranty terms.

1. Warranty period: one year for POS.
2. In warranty period, wizarPOS provide free repair/replace service, if the product has non artificial product failures.
3. Welcome to contact WizarPOS or the its authorized distributors for supports.
4. Please show product warranty card with true information.

Warranty limitation clause

Situations due to following reasons are not covered under warranty policies. A charge service will be applied.

1. The POS is maintained/repared by unauthorized party without WizarPOS permission.
2. The OS of POS is unauthorized changed by user.
3. The trouble is caused by the third party APP which is installed by user.
4. Damage due to improper use which like falling, squeeze, hit, soaking, burning, ..
5. No warranty card, or cannot provide true information in card.
6. Expiry of guarantee period.
7. Other conditions which is forbidden by laws.

List of harmful substances in the product and logo of environment-friendly use period.

Part	Harmful substances					
	Pb	Hg	Cd	Cr(VI)	PBB	PBDE
LCD and TP Module	○	○	○	○	○	○
Housing and keypad	○	○	○	○	○	○
PCBA and components	×	○	○	○	○	○
Accessories	×	○	○	○	○	○

This table is made according to requirement of SJ/T 11364.
○ means the harmful substance concentration in the parts is under the limits in GB/T 26572.
× means the harmful substance concentration of one or more homogeneous materials in the parts is exceeded the limits in GB/T 26572.

NOTE: Parts which marked × are compliant to China RoHS Regulation and EU RoHS Directive.



This is environment-friendly use period logo of the product. This logo means that in this period the product will not leak harmful substances in normal usage.

Trouble	Trouble shooting
Cannot connect the mobile network	<ul style="list-style-type: none"> ◆ Check whether the function of "data" is open. ◆ Check whether the APN is correct. ◆ Check whether the data service of SIM is active.
No response	◆ Restart the APP or operation system.
Operation very slow	◆ Please stop active APPs which are not necessary.

Repair date	Repair content

Welcome to contact WizarPOS, or the local distributors for quickly support.
For more information, please log on to the company's official website
<http://www.wizarpos.com>



V1.0, Jun 2022

FCC Warning

This device complies with part 15 of the FCC rules. Operation is subject to the following two conditions: (1) this device may not cause harmful interference, and (2) this device must accept any interference received, including interference that may cause undesired operation.

Changes or modifications not expressly approved by the party responsible for compliance could void the user's authority to operate the equipment.

NOTE: This equipment has been tested and found to comply with the limits for a Class B digital device, pursuant to part 15 of the FCC Rules. These limits are designed to provide reasonable protection against harmful interference in a residential installation. This equipment generates uses and can radiate radio frequency energy and, if not installed and used in accordance with the instructions, may cause harmful interference to radio communications. However, there is no guarantee that interference will not occur in a particular installation. If this equipment does cause harmful interference to radio or television reception, which can be determined by turning the equipment off and on, the user is encouraged to try to correct the interference by one or more of the following measures:

- Reorient or relocate the receiving antenna.
- Increase the separation between the equipment and receiver.
- Connect the equipment into an outlet on a circuit different from that to which the receiver is connected.
- Consult the dealer or an experienced radio/TV technician for help.

Radiation Exposure Statement

This equipment complies with FCC radiation exposure limits set forth for an uncontrolled environment. This equipment should be installed and operated with minimum distance 20cm between the radiator and your body.