

- 1 Q2 Terminal
- 2 5V 2A Adapter
- 3 DC Cable
- 4 7.2V Lithium Battery

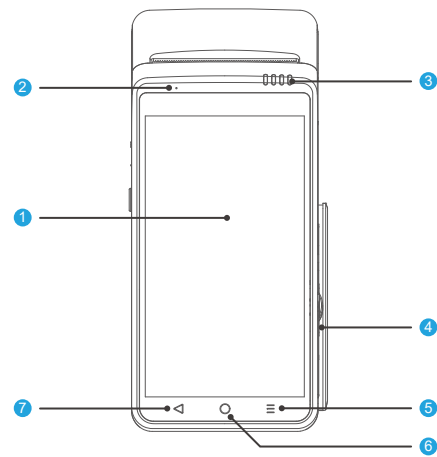

- 1 5.5" Capacitive Touch Screen
- 2 MIC
- 3 4 Indicators
- 4 Magnetic Card Reader
- 5 Menu Button
- 6 Home Button
- 7 Return Button

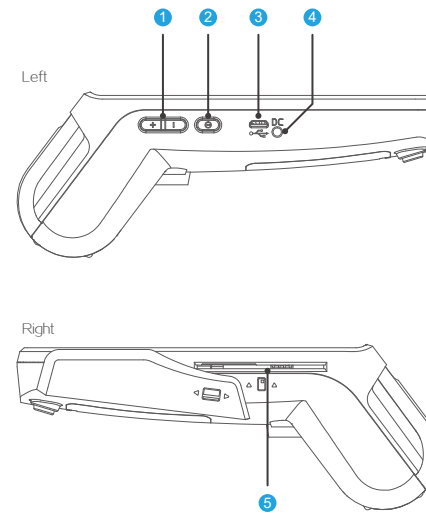

- 1 Volume Keys
- 2 Power Key
- 3 Micro USB Port
- 4 DC Port
- 5 IC Card Reader

Q2 Smart POS

User Manual



www.wizarpos.com

Top

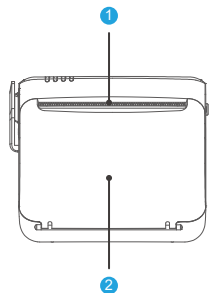

Bottom



- 1 58mm Thermal Printer
- 2 Contactless Card Reader

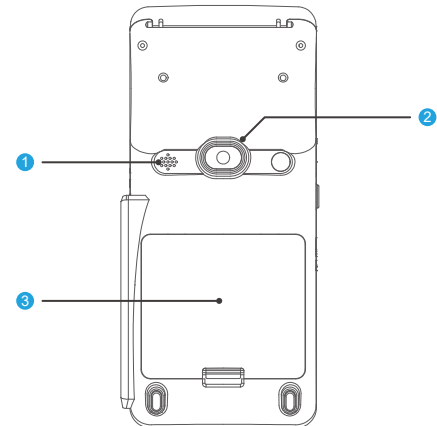

- 1 Speaker
- 2 Camera
- 3 Battery Compartment Cover

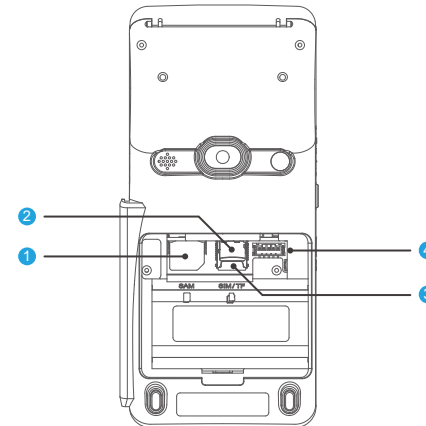

- 1 SAM/SIM card slot
- 2 TF Card Slot
- 3 Micro SIM Card Slot
- 4 Battery Connector

Thank you for using the product of WizarPOS !

Intelligent + Security



Certification in progress ...

1 Before use

- a) Please insert the battery first, and fix the battery cover.
- b) Please charge if the battery has not enough power.
- c) Load the paper roll, and close the printer cover.

2 Power on and off

- a) Press "power" key for 3 seconds, you can power on the POS.
- b) After secure booting, it will display desktop, you can operate the POS.
- c) You can turn on/off the LCD by quickly press the "Power" key.
- d) When the POS is power on, press "power" key for 3 seconds, it will display the power off menu, follow the menu to power off the POS.

3 System setup

- a) Pull down the status bar at the top of desktop, it will display the notification interface.
- b) Click the menu icon in upper right corner of the screen, it will display the function switch interface.
- c) Click the "setup" icon, it will display the setup interface. Please setup the POS if needed.

4 Payment operation

Please follow the instructions of your payment APP provider.

5 Bank card operation

- a) Please insert the chip card into the smart card slot with the chip end facing up.
- b) Swipe the magnetic stripe card with magnetic stripe facing to screen, you can bi-directional swipe the card.
- c) Tap the contactless card close to the card reader area quickly.

Specification	Detailed Description
Software Platform	Secure Android 6.x
Processor	Qualcomm Snapdragon CPU
Memory	1GB RAM, 8GB Flash, Optional 2GB RAM, 16GB Flash
Display	5.5" color LCD with touch panel (720 × 1280)
Printer	58mm High speed Thermal Printer
Scanner	barcode and 2D barcode scanner
Security Certification	PCI PTS 5.0
Contactless Card	ISO14443 Type A & B, Mifare, Contactless EMV Level 1, Mastercard Paypass, Visa Paywave
IC Card	ISO7816, EMV Level 1 & Level 2
MSR	ISO7811, Track 1/2/3, Bi-direction
Slots	1SIM/1SAM slot, 1Micro SIM slot, TF card × 1
Communication	GSM, CDMA2000, WCDMA, FDD-LTE, TDD-LTE,Wi-Fi
Audio	Built-in microphone, speaker
USB	Micro USB OTG
Battery	7.2V, 2600mAh
Charging	5V 2A adapter, supports USB charging
Dimension	188 × 85 × 69 mm
Weight	415g (No printing paper)

All features and specifications are subject to change without notice. Contact wizarPOS website for more details.

www.wizarpos.com

Environment

- Operating temperature
-5°C~40°C (+23°F to 104°F)
- Operating humidity
5%-95% No condensation
- Storage temperature
-20°C~60°C (-4°F to 140°F)
- Storage Humidity
10%~93% No condensation

Attention

- ◆ Do **NOT** refit the POS, that is illegal to privately refit financial POS.
- ◆ User shall bear the risks of installation and usage of third party APPs.
- ◆ The system will become slow if too many APPs installed.
- ◆ Please use dry and clean cloth to clean the POS, Do **NOT** use chemical.
- ◆ Do **NOT** expose the POS under heavy sunlight for long time.
- ◆ Do **NOT** use sharp and hard objects to touch the screen.
- ◆ Do **NOT** throw the POS, charger or battery as common household garbage. Please support recycle according to local environment rules.
- ◆ Please use the original battery and charger, otherwise that may cause product damage or personal injury.
- ◆ Do **NOT** put the battery into fire, otherwise it will cause explosion.
- ◆ The battery is forbidden to immerse, the battery can not be used again after entering the water.
- ◆ Do **NOT** short circuit battery, otherwise that will cause personal injury or battery permanent damaged.
- ◆ If battery is deformed or in abnormal heat, stop using it and replace it with new battery.
- ◆ Replacing with a wrong model battery may cause an explosion.

Trouble	Trouble shooting
Cannot connect the mobile network	<ul style="list-style-type: none"> ◆ Check whether the function of "data" is open. ◆ Check whether the APN is correct. ◆ Check whether the data service of SIM is activated.
Paper jam	<ul style="list-style-type: none"> ◆ Reload the paper roll, or check if there is crease on paper roll. ◆ Check if the cover of printer is closed. ◆ Check whether the slot is blocked by the receipt of last transaction . ◆ Check if the print roller is missing.
Display unstable	<ul style="list-style-type: none"> ◆ The display may be interfered by instability voltage when charging, please reconnect the plug.
No response	<ul style="list-style-type: none"> ◆ Restart the APP or operation system.
Operation very slow	<ul style="list-style-type: none"> ◆ Please exit APPs which are not necessary.

Product warranty policy

WizarPOS provide after-sales service according to relative laws. Please read the following warranty terms.

1. Warranty period: one year for POS and charger, and 6 months for battery cell.
2. In warranty period, wizarPOS provide free repair/replace service, if the product has non artificial product failures.
3. It's recommended to contact your local distributor firstly for supports.
4. Please show product warranty card with true information.

Warranty limitation clause

Situations due to following reasons are not covered under warranty policies. While we can provide charge service.

1. Without our permission, the POS is maintenance by user.
2. The OS of POS is changed by user without permission from WizarPOS.
3. The trouble is caused by the third party APP which is installed by user.
4. Damage due to improper use which like falling, squeeze, hit, soaking, burning...
5. No warranty card, or cannot provide true information in card.
6. Expiry of guarantee period.
7. Caused by other actions which are forbidden by related laws.

List of harmful substances in the product and logo of environment-friendly use period.

Part	Harmful substances					
	Pb	Hg	Cd	Cr(VI)	PBB	PBDE
LCD and TP Module	○	○	○	○	○	○
Housing and keypad	○	○	○	○	○	○
PCBA and components	×	○	○	○	○	○
Accessories	×	○	○	○	○	○

This table is made according to requirement of SJ/T 11364.
 ○ means the harmful substance concentration in the parts is under the limits in GB/T 26572.
 × means the harmful substance concentration of one or more homogeneous materials in the parts is exceeded the limits in GB/T 26572.
 NOTE: Parts which marked × are compliant to China RoHS Regulation and EU RoHS Directive.



This is environment-friendly use period logo of the product. This logo means that in this period the product will not leak harmful substances in normal usage.

Repair date	Repair content

After-Sale Service Hotline: 400-608-2601

For more information, please log on to the company's official website <http://www.wizarpos.com>

wizarPOS
400-608-2601

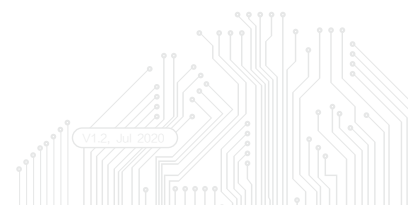

FCC Statement

This equipment has been tested and found to comply with the limits for a Class B digital device, pursuant to part 15 of the FCC Rules. These limits are designed to provide reasonable protection against harmful interference in a residential installation. This equipment generates, uses and can radiate radio frequency energy and, if not installed and used in accordance with the instructions, may cause harmful interference to radio communications. However, there is no guarantee that interference will not occur in a particular installation. If this equipment does cause harmful interference to radio or television reception, which can be determined by turning the equipment off and on, the user is encouraged to try to correct the interference by one or more of the following measures:

- Reorient or relocate the receiving antenna.
- Increase the separation between the equipment and receiver.
- Connect the equipment into an outlet on a circuit different from that to which the receiver is connected.
- Consult the dealer or an experienced radio/TV technician for help.

Caution: Any changes or modifications to this device not explicitly approved by manufacturer could void your authority to operate this equipment.

This device complies with part 15 of the FCC Rules. Operation is subject to the following two conditions: (1) This device may not cause harmful interference, and (2) this device must accept any interference received, including interference that may cause undesired operation.

Specific Absorption Rate (SAR) information:

This Smart POS meets the government's requirements for exposure to radio waves. The guidelines are based on standards that were developed by independent scientific organizations through periodic and thorough evaluation of scientific studies. The standards include a substantial safety margin designed to assure the safety of all persons regardless of age or health. FCC RF Exposure Information and Statement the SAR limit of USA (FCC) is 1.6 W/kg averaged over one gram of tissue. Device types: Smart POS has also been tested against this SAR limit. This device was tested for typical body-worn operations with the back of the phone kept 10mm from the body. To maintain compliance with FCC RF exposure requirements, use accessories that maintain an 10mm separation distance between the user's body and the back of the phone. The use of belt clips, holsters and similar accessories should not contain metallic components in its assembly. The use of accessories that do not satisfy these requirements may not comply with FCC RF exposure requirements, and should be avoided.