

Test Report

FCC ID:2AG8N-FEX

Date of issue: Mar. 05, 2018

Report Number:	MTi180305E010
Sample Description:	String Light Speaker
Model(s):	VSS60014BT-FEX, VSS60014BT, E-BS-17247-A
Applicant:	China Etech Groups Ltd
Address:	Room 3A15-3A18, Floor4, BlockC, Bao Yuan HuaFeng Headquarter, economy building, Xixiang Road, Xixiang Street, Baoan district, Shenzhen
Date of Test:	Feb. 07, 2018 to Mar. 05, 2018

Shenzhen Microtest Co., Ltd.
<http://www.mtitest.com>

This test report is valid for the tested samples only. It cannot be reproduced except in full without prior written consent of Shenzhen Microtest Co., Ltd.

Tel:(86-755)88850135

Fax: (86-755) 88850136

Web: <http://www.mtitest.com>

E-mail: mti@51mti.com

Address: No.102A & 302A, East Block, Hengfang Industrial Park, Xingye Road, Xixiang, Bao'an District, Shenzhen, Guangdong, China

Revision History

Revised edition	Issue date	Descriptions
Rev.1	Mar. 05, 2018	1st edition

Table of Contents

1	GENERAL INFORMATION	6
1.1	DESCRIPTION OF EUT	6
1.2	OPERATION CHANNEL LIST	6
1.3	TEST CHANNEL LIST	7
1.4	ANCILLARY EQUIPMENT LIST	7
1.5	DESCRIPTION OF SUPPORT UNITS	7
2	SUMMARY OF TEST RESULTS	8
3	TEST FACILITIES AND ACCREDITATIONS	9
3.1	TEST LABORATORY	9
3.2	ENVIRONMENTAL CONDITIONS	9
3.3	MEASUREMENT UNCERTAINTY	9
3.4	TEST SOFTWARE	9
4	EQUIPMENT LIST	10
5	TEST RESULT	11
5.1	ANTENNA REQUIREMENT	11
5.1.1	<i>Standard requirement</i>	11
5.1.2	<i>EUT Antenna</i>	11
5.2	PEAK OUTPUT POWER	12
5.2.1	<i>Limit</i>	12
5.2.2	<i>Test setup</i>	12
5.2.3	<i>Test procedure</i>	12
5.2.4	<i>EUT operation condition</i>	12
5.2.5	<i>Test results</i>	12
5.3	CONDUCTED EMISSION	16
5.3.1	<i>Limits</i>	16
5.3.2	<i>Test setup</i>	16
5.3.3	<i>Test procedure</i>	17
5.3.4	<i>Test results</i>	17
5.4	RADIATED SPURIOUS EMISSION	20
5.4.1	<i>Limits</i>	20
5.4.2	<i>Test setup</i>	21
5.4.3	<i>Test procedure</i>	22
5.4.4	<i>Test results</i>	23
5.4.4.1	<i>Radiation emission</i>	23
5.4.4.2	<i>Band edge - radiated</i>	28
5.5	20dB OCCUPIED CHANNEL BANDWIDTH	29
5.5.1	<i>Limit</i>	29
5.5.2	<i>Test setup</i>	29
5.5.3	<i>Test procedure</i>	29
5.5.4	<i>EUT Operation Conditions</i>	29
5.5.5	<i>Test results</i>	29
5.6	BAND EDGE - CONDUCTED	34
5.6.1	<i>Limit</i>	34
5.6.2	<i>Test setup</i>	34
5.6.3	<i>Test procedure</i>	34
5.6.4	<i>EUT operation conditions</i>	34
5.6.5	<i>Test results</i>	34
5.7	CARRIER FREQUENCY SEPARATION	41
5.7.1	<i>Limit</i>	41
5.7.2	<i>Test setup</i>	41

5.7.3	Test procedure.....	41
5.7.4	EUT operation conditions.....	41
5.7.5	Test results.....	41
5.8	DWELL TIME.....	45
5.8.1	Limit	45
5.8.2	Test setup	45
5.8.3	Test procedure.....	45
5.8.4	EUT operation conditions.....	45
5.8.5	Test results.....	45
PHOTOGRAPHS OF THE TEST SETUP.....		49

TEST REPORT

Applicant's name: China Etech Groups Ltd
Address: Room 3A15-3A18, Floor4, BlockC, Bao Yuan HuaFeng Headquarter, economy building, Xixiang Road, Xixiang Street, Baoan district, Shenzhen

Manufacture's Name: Dongguan China Etech Groups Ltd
Address: 2F, Building B, NO.77, Shachong Road, Shatou Community, Changan Town, Dongguan, Guangdong.

Product name: String Light Speaker

Trademark: Vivitar

Model name: VSS60014BT-FEX, VSS60014BT, E-BS-17247-A

Standards: FCC Part 15.247

Test Procedure: ANSI C63.10-2013
DA 00-705

This device described above has been tested by Shenzhen Microtest Co., Ltd and the test results show that the equipment under test (EUT) is in compliance with the FCC requirements. And it is applicable only to the tested sample identified in the report.

Tested by:

Amy Lu

Amy Lu

Mar. 05, 2018

Reviewed by:

Blue Zheng

Blue Zheng

Mar. 05, 2018

Approved by:

Smith Chen

Smith Chen

Mar. 05, 2018

1 General Information

1.1 Description of EUT

Product name	String Light Speaker
Model name	VSS60014BT-FEX
Serial Model	VSS60014BT, E-BS-17247-A
Operation Frequency	TX 2402-2480MHz RX 2402-2480MHz
Number Of Channel	79
Modulation Type:	GFSK, $\pi/4$ -DQPSK
Bit Rate of Transmitter:	1 Mbps, 2 Mbps
Max. Output Power:	-5.497dBm
Antenna Type:	PCB antenna (Antenna Gain -0.68dBi)
Supply Voltage:	DC 5V from adapter AC 120V/60Hz
Model Difference:	Only the models is named differently

1.2 Operation channel list

Channel	Frequency (MHz)	Channel	Frequency (MHz)	Channel	Frequency (MHz)
00	2402	27	2429	54	2456
01	2403	28	2430	55	2457
02	2404	29	2431	56	2458
03	2405	30	2432	57	2459
04	2406	31	2433	58	2460
05	2407	32	2434	59	2461
06	2408	33	2435	60	2462
07	2409	34	2436	61	2463
08	2410	35	2437	62	2464
09	2411	36	2438	63	2465
10	2412	37	2439	64	2466
11	2413	38	2440	65	2467
12	2414	39	2441	66	2468
13	2415	40	2442	67	2469
14	2416	41	2443	68	2470
15	2417	42	2444	69	2471
16	2418	43	2445	70	2472
17	2419	44	2446	71	2473
18	2420	45	2447	72	2474
19	2421	46	2448	73	2475

20	2422	47	2449	74	2476
21	2423	48	2450	75	2477
22	2424	49	2451	76	2478
23	2425	50	2452	77	2479
24	2426	51	2453	78	2480
25	2427	52	2454	--	--
26	2428	53	2455	--	--

1.3 Test channel list

Channel	Channel	Frequency (MHz)
Low	00	2402
Middle	39	2441
High	79	2480

1.4 Ancillary equipment list

Equipment	Model	S/N	Manufacturer	Certificate type
/	/	/	/	/

1.5 Description of Support Units

The EUT has been tested as an independent unit together with other necessary accessories or support units. The following support units or accessories were used to form a representative test configuration during the tests.

Item	Equipment	Brand	Model/Type No.	Series No.	Note
E-1	String Light Speaker	Vivitar	VSS60014BT-FEX	N/A	EUT
E-1	Adapter	Huawei	N/A	N/A	

Note:

(1)The support equipment was authorized by Declaration of Confirmation.

(2)For detachable type I/O cable should be specified the length in cm in 『Length』 column.

2 Summary of Test Results

Test procedures according to the technical standards:

No.	Standard Section	Test Item	Result	Remark
1	15.203/15.247(c)	Antenna requirement	Pass	
2	15.247(b)(1)	Peak output power	Pass	
3	15.207	Conducted emission	Pass	
4	15.247(d)	Band edge	Pass	
5	15.205/15.209	Spurious emission	Pass	
6	15.247(a)(1)	20dB occupied bandwidth	Pass	
7	15.247(a)(1)	Carrier Frequencies Separation	Pass	
8	15.247(a)(1)	Hopping channel number	Pass	
9	15.247(a)(1)	Dwell time	Pass	

3 Test Facilities and Accreditations

3.1 Test laboratory

Test Laboratory	Shenzhen Microtest Co., Ltd
Location	No.102A & 302A, East Block, Hengfang Industrial Park, Xingye Road, Xixiang, Bao'an District, Shenzhen, Guangdong, China
FCC Registration No.:	448573

3.2 Environmental conditions

Temperature:	20°C~30°C
Humidity	30%~70%
Atmospheric pressure	98kPa~101kPa

3.3 Measurement uncertainty

The reported uncertainty of measurement $y \pm U$ where expanded uncertainty U is based on a standard uncertainty multiplied by a coverage factor of $k=2$ providing a level of confidence of approximately 95 %

No.	Item	Uncertainty
1	Conducted Emission Test	$\pm 1.38\text{dB}$
2	RF power, conducted	$\pm 0.16\text{dB}$
3	Spurious emissions, conducted	$\pm 0.21\text{dB}$
4	All emissions, radiated(<1G)	$\pm 4.68\text{dB}$
5	All emissions, radiated(>1G)	$\pm 4.89\text{dB}$
6	Temperature	$\pm 0.5^\circ\text{C}$
7	Humidity	$\pm 2\%$

3.4 Test software

Software Name	Manufacturer	Model	Version
RF Test System	Farad	LZ-RF	Lz_Rf 3A3

4 Equipment list

Equipment No.	Equipment Name	Manufacturer	Model	Serial No.	Calibration date	Due date
MTI-E001	Spectrum Analyzer	Agilent	E4407B	MY41441082	2017/09/18	2018/09/17
MTI-E002	CMU 200 universal radio communication tester	Rohde&schwarz	CMU 200	114587	2017/09/18	2018/09/17
MTI-E004	EMI Test Receiver	Rohde&schwarz	ESPI	1000314	2017/09/18	2018/09/17
MTI-E006	Broadband antenna	schwarabeck	VULB9163	872	2017/09/18	2018/09/17
MTI-E007	Horn antenna	schwarabeck	BBHA9120D	1201	2017/09/18	2018/09/17
MTI-E014	amplifier	America	8447D	3113A06150	2017/09/18	2018/09/17
MTI-E015	Conduction Immunity Signal Generator	Schloder	CDG6000	126A1343/2015	2017/09/18	2018/09/17
MTI-E016	Coupled decoupling network	Schloder	CDA M2/M3	A2210332/2015	2017/09/18	2018/09/17
MTI-E032	Comprehensive test instrument	Rohde&schwarz	CMW500	124192	2017/04/13	2018/04/12
MTI-E034	amplifier	Agilent	8449B	3008A02400	2017/08/22	2018/08/21
MTI-E040	Spectrum analyzer	Agilent	N9020A	MY49100060	2018/03/04	2019/03/04
MTI-E041	Signal generator	Agilent	N5182A	MY49060455	2018/02/22	2019/02/22
MTI-E042	Analog signal generator	Agilent	E4421B	GB40051240	2018/02/22	2019/02/22
MTI-E043	Power probe	Dare Instruments	RPR3006W	16I00054SN016	2018/02/28	2019/02/28
MTI-E047	10dB attenuator	Mini-Circuits	UNAT-10+	15542	2017/05/23	2018/05/23
MTI-E049	spectrum analyzer	Rohde&schwarz	FSP-38	100019	2017/09/18	2018/09/17
MTI-E050	PSG Signal generator	Agilent	E8257D	MY46520873	2017/04/24	2018/04/23
MTI-E051	Active Loop Antenna 9kHz - 30MHz	Schwarzbeek	FMZB 1519 B	00044	2018//2/26	2019/02/25
MTI-E052	18-40GHz amplifier	Chengdu step Micro Technology	ZLNA-18-40G-21	1608001	2017/09/18	2018/09/17
MTI-E053	15-40G Antenna	Schwarzbeek	BBHA9170	BBHA9170582	2017/09/18	2018/09/17

Note: the calibration interval of the above test instruments is 12 months and the calibrations are traceable to international system unit (SI).

5 Test Result

5.1 Antenna requirement

5.1.1 Standard requirement

15.203 requirement: For intentional device, according to 15.203: an intentional radiator shall be designed to ensure that no antenna other than that furnished by the responsible party shall be used with the device

5.1.2 EUT Antenna

The EUT antenna is integrated antenna. It comply with the standard requirement. In case of replacement of broken antenna the same antenna type must be used.

5.2 Peak output power

5.2.1 Limit

FCC Part15 Subpart C			
Section	Test Item	Limit	Frequency Range (MHz)
15.247(b)(3)	Peak output power	Hopping Channels>75 Power<1W(30dBm)	2400-2483.5

5.2.2 Test setup



5.2.3 Test procedure

- (1) The EUT was directly connected to the spectrum analyzer and antenna output port as show in the block diagram above.
- (2) Spectrum Setting:
RBW=1MHz, VBW=3MHz, Detector=Peak (If 20dB BW ≤1 MHz)
RBW=3MHz, VBW=10MHz, Detector=Peak (If 20dB BW > 1 MHz)
- (3) The EUT was set to continuously transmitting in the max power during the test.

5.2.4 EUT operation condition

The EUT tested system was configured as the statements of 2.4 Unless otherwise a special operating condition is specified in the follows during the testing.

5.2.5 Test results

Test data

EUT :	String Light Speaker	Model Name :	VSS60014BT-FEX
Temperature :	25 °C	Relative Humidity :	60%
Pressure :	1012 hPa	Test Voltage :	DC 5V from adapter AC 120V/60Hz

GFSK

Test Channel	Frequency (MHz)	Maximum Conducted Output Power(PK)	Limit (dBm)
CH00	2402	-8.058	30
CH39	2441	-6.763	30
CH78	2480	-6.977	30

$\pi/4$ -DQPSK

Test Channel	Frequency (MHz)	Maximum Conducted Output Power(PK)	Limit (dBm)
CH00	2402	-6.870	20.96
CH39	2441	-5.497	20.96
CH78	2480	-5.722	20.96

GFSK:

2402MHz

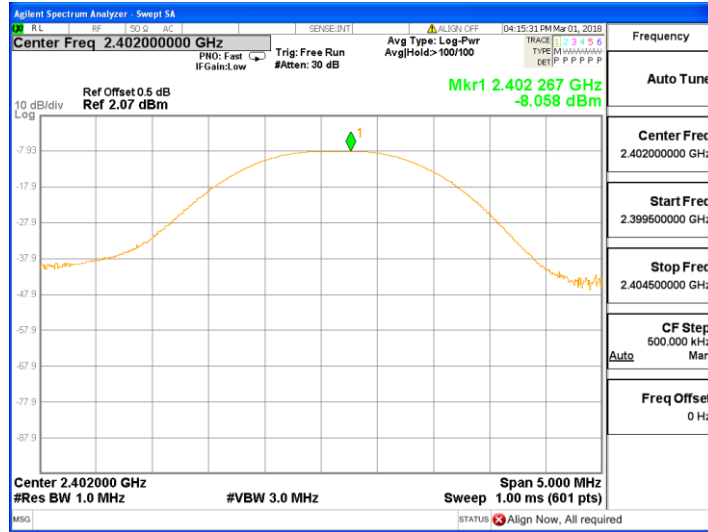

2441MHz

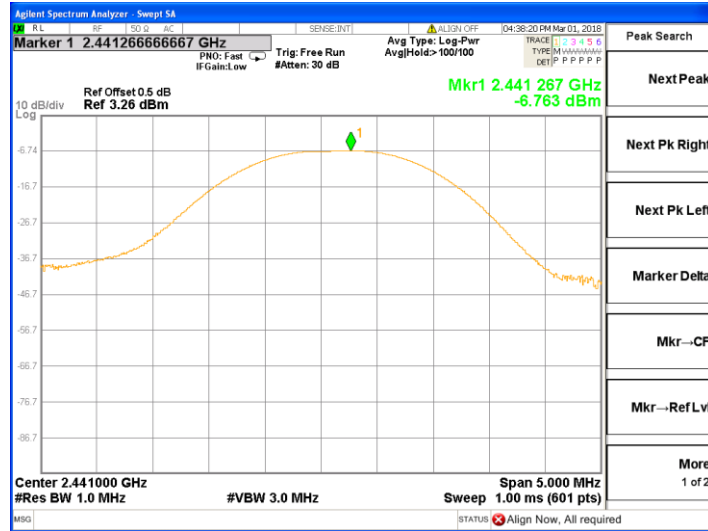

2480MHz

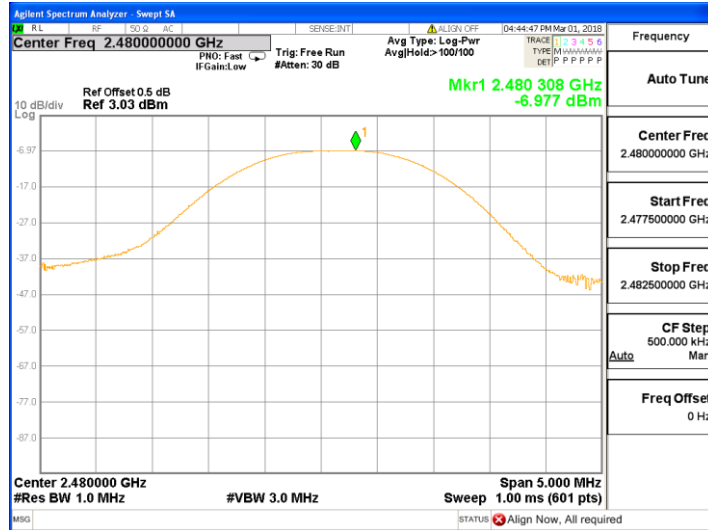

$\pi/4$ -DQPSK

2402MHz

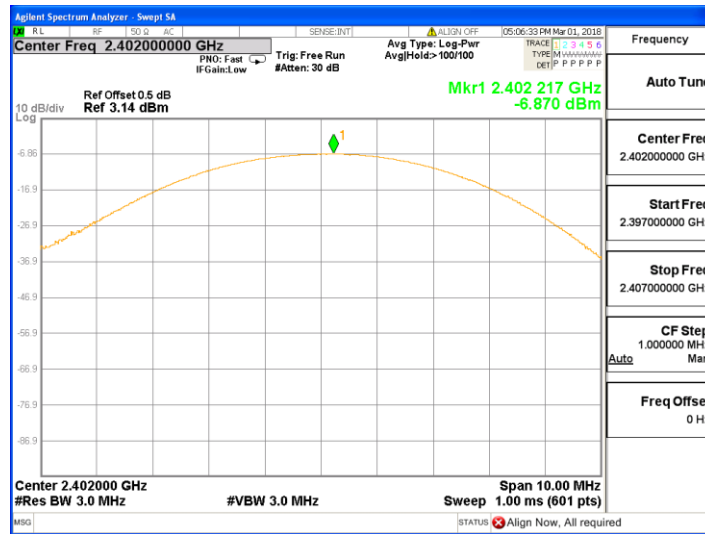

2441MHz

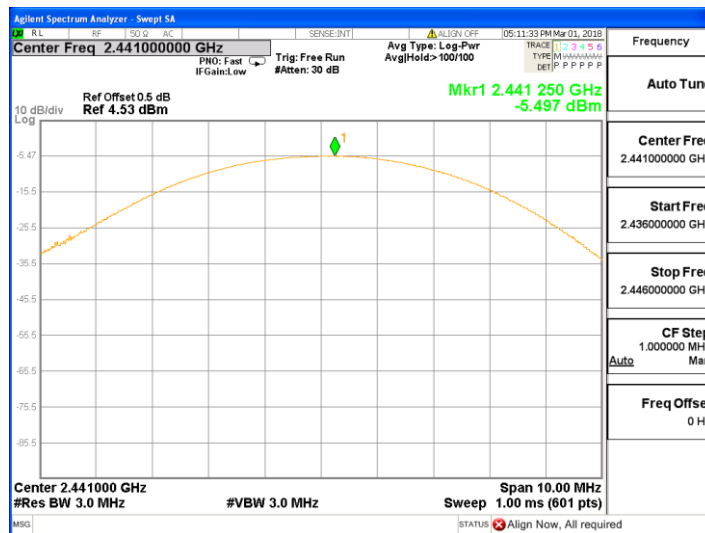

2480MHz

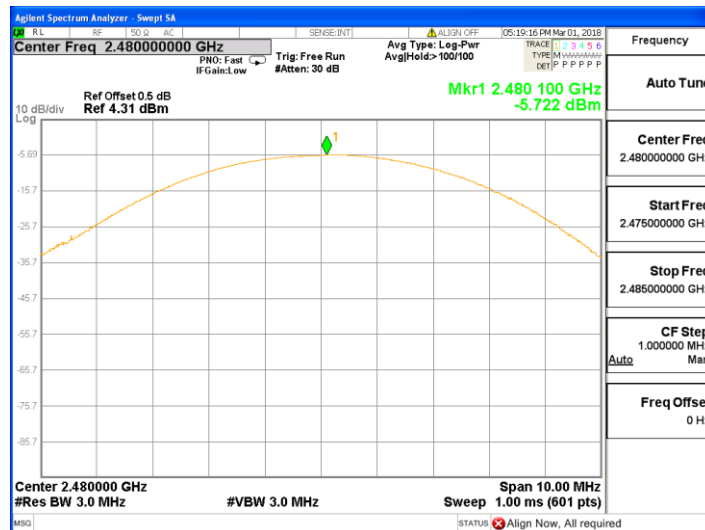

5.3 Conducted emission

5.3.1 Limits

FREQUENCY (MHz)	Class B (dBuV)	
	Quasi-peak	Average
0.15 -0.5	66 - 56 *	56 - 46 *
0.50 -5.0	56.00	46.00
5.0 -30.0	60.00	50.00

Note

(1)The tighter limit applies at the band edges.

(2)The limit of " * " marked band means the limitation decreases linearly with the logarithm of the frequency in the range.

5.3.2 Test setup

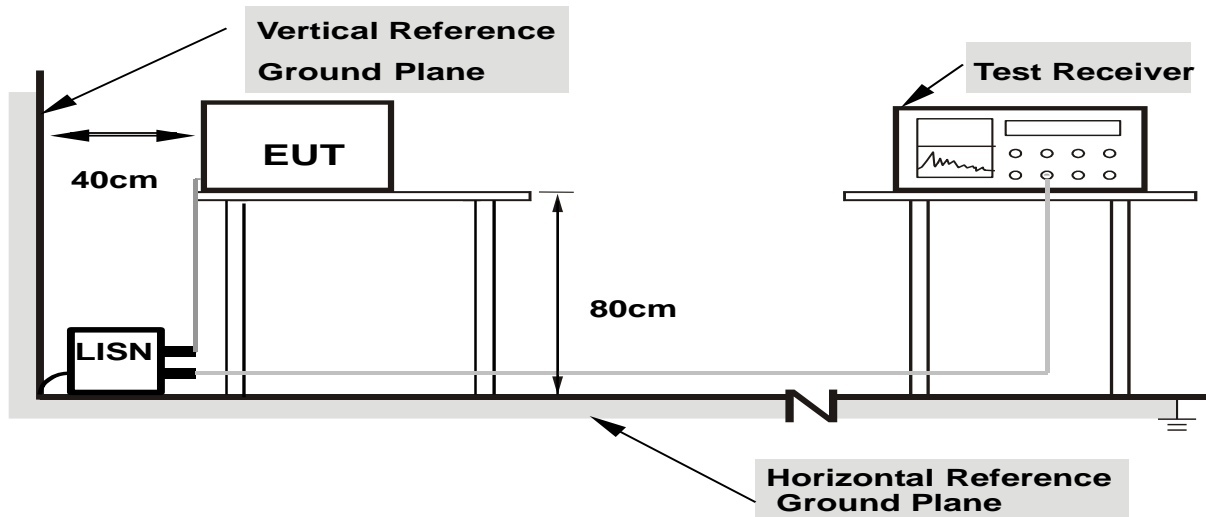

Note: 1.Support units were connected to second LISN.

2.Both of LISNs (AMN) are 80 cm from EUT and at least 80 from other units and other metal planes

5.3.3 Test procedure

a. EUT Operating Conditions

The EUT was configured for testing in a typical fashion (as a customer would normally use it). The EUT has been programmed to continuously transmit during test. This operating condition was tested and used to collect the included data.

b. The following table is the setting of the receiver

Receiver Parameters	Setting
Attenuation	10 dB
Start Frequency	0.15 MHz
Stop Frequency	30 MHz
IF Bandwidth	9 kHz

- c. The EUT was placed 0.8 meters from the horizontal ground plane with EUT being connected to the power mains through a line impedance stabilization network (LISN). All other support equipments powered from additional LISN(s). The LISN provide 50 Ohm/ 50uH of coupling impedance for the measuring instrument.
- d. Interconnecting cables that hang closer than 40 cm to the ground plane shall be folded back and forth in the center forming a bundle 30 to 40 cm long.
- e. I/O cables that are not connected to a peripheral shall be bundled in the center. The end of the cable may be terminated, if required, using the correct terminating impedance. The overall length shall not exceed 1 m.
- f. LISN at least 80 cm from nearest part of EUT chassis.

For the actual test configuration, please refer to the related Item –EUT Test Photos.

5.3.4 Test results

Test data

EUT :	String Light Speaker	Model Name. :	VSS60014BT-FEX
Temperature :	26 °C	Relative Humidity :	54%
Pressure :	1010hPa	Phase :	L
Test Voltage :	DC 5V from adapter AC 120V/60Hz AC 120V/60Hz	Test Mode :	TX Mode

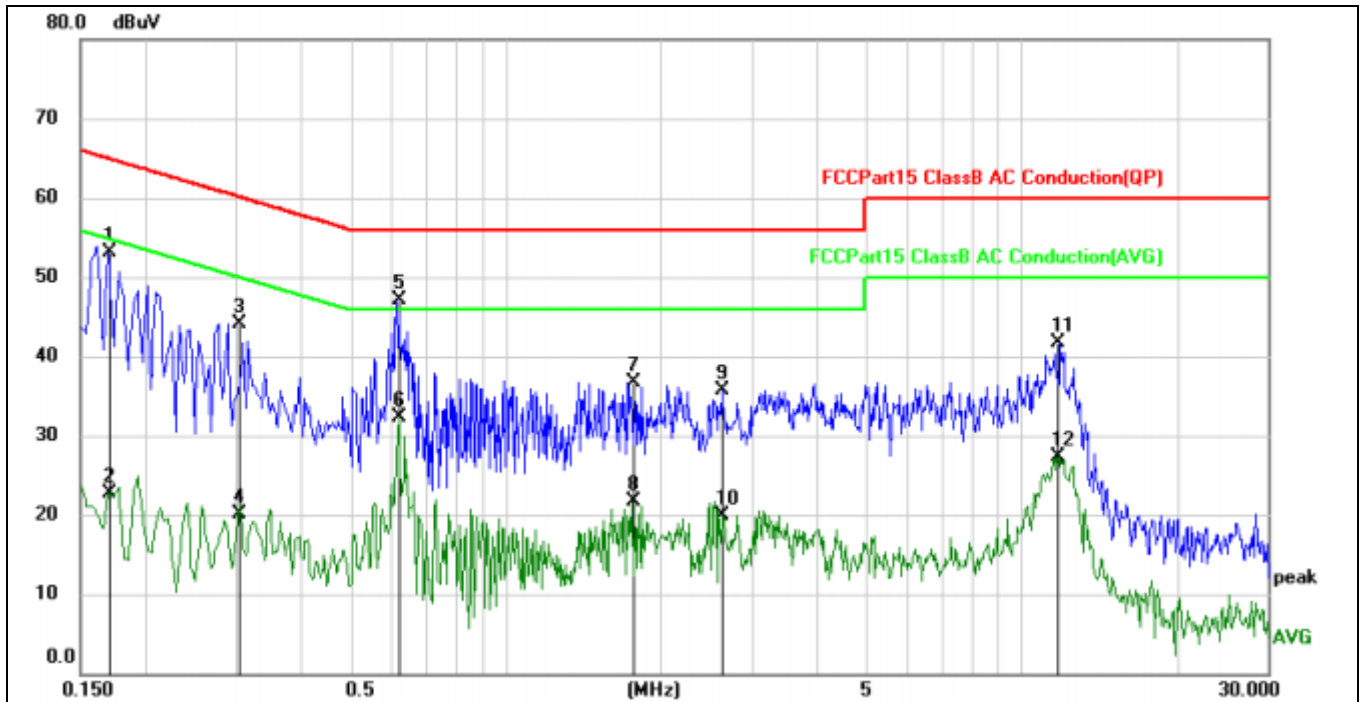

No.	Mk.	Freq. MHz	Reading Level dBuV	Correct Factor dB	Measure- ment dBuV	Limit dBuV	Over dB	Detector	Comment
1		0.1700	51.57	1.57	53.14	64.96	-11.82	QP	
2		0.1700	21.08	1.57	22.65	54.96	-32.31	AVG	
3		0.3035	42.60	1.57	44.17	60.15	-15.98	QP	
4		0.3035	18.49	1.57	20.06	50.15	-30.09	AVG	
5	*	0.6220	45.49	1.57	47.06	56.00	-8.94	QP	
6		0.6220	30.71	1.57	32.28	46.00	-13.72	AVG	
7		1.7660	35.11	1.59	36.70	56.00	-19.30	QP	
8		1.7660	20.12	1.59	21.71	46.00	-24.29	AVG	
9		2.6260	34.51	1.18	35.69	56.00	-20.31	QP	
10		2.6260	18.75	1.18	19.93	46.00	-26.07	AVG	
11		11.7100	41.34	0.36	41.70	60.00	-18.30	QP	
12		11.7100	26.99	0.36	27.35	50.00	-22.65	AVG	

EUT :	String Light Speaker	Model Name. :	VSS60014BT-FEX
Temperature :	26 °C	Relative Humidity :	54%
Pressure :	1010hPa	Phase :	N
Test Voltage :	DC 5V from adapter AC 120V/60Hz AC 120V/60Hz	Test Mode :	TX Mode

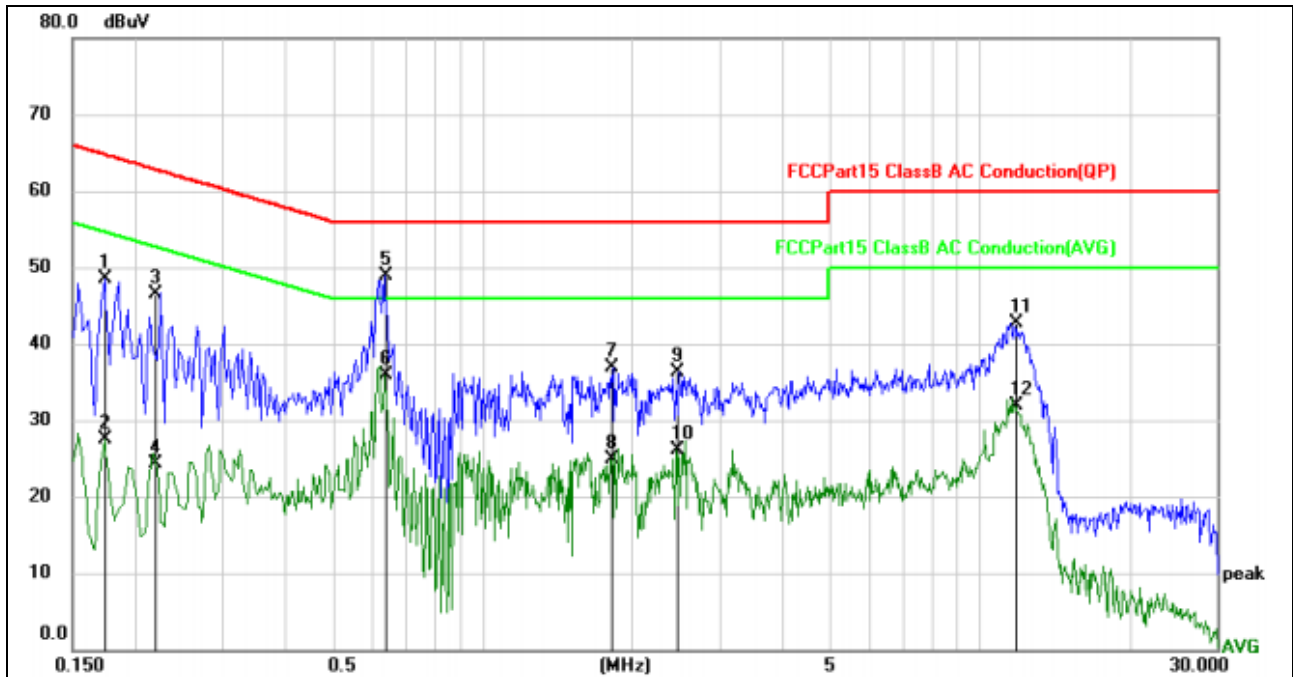

No.	Mk.	Freq. MHz	Reading Level dBuV	Correct Factor dB	Measure- ment dBuV	Limit dBuV	Over dB	Detector	Comment
1		0.1740	46.88	1.57	48.45	64.77	-16.32	QP	
2		0.1740	25.86	1.57	27.43	54.77	-27.34	AVG	
3		0.2208	45.03	1.57	46.60	62.79	-16.19	QP	
4		0.2208	22.70	1.57	24.27	52.79	-28.52	AVG	
5	*	0.6380	47.37	1.57	48.94	56.00	-7.06	QP	
6		0.6380	34.25	1.57	35.82	46.00	-10.18	AVG	
7		1.8100	35.40	1.59	36.99	56.00	-19.01	QP	
8		1.8100	23.38	1.59	24.97	46.00	-21.03	AVG	
9		2.4539	35.02	1.27	36.29	56.00	-19.71	QP	
10		2.4539	24.82	1.27	26.09	46.00	-19.91	AVG	
11		11.7540	42.40	0.36	42.76	60.00	-17.24	QP	
12		11.7540	31.62	0.36	31.98	50.00	-18.02	AVG	

5.4 Radiated spurious emission

5.4.1 Limits

Frequency (MHz)	Field Strength (micovolts/meter)	Measurement Distance (meters)
0.009~0.490	2400/F(KHz)	300
0.490~1.705	24000/F(KHz)	30
1.705~30.0	30	30
30~88	100	3
88~216	150	3
216~960	200	3
Above 960	500	3

Spectrum Parameter	Setting
Attenuation	Auto
Start Frequency	1000 MHz
Stop Frequency	10th carrier harmonic
RB / VB (emission in restricted band)	1 MHz / 1 MHz for Peak, 1 MHz / 10Hz for Average

Receiver Parameter	Setting
Attenuation	Auto
Start ~ Stop Frequency	9kHz~150kHz / RB 200Hz for QP
Start ~ Stop Frequency	150kHz~30MHz / RB 9kHz for QP
Start ~ Stop Frequency	30MHz~1000MHz / RB 120kHz for QP

5.4.2 Test setup

Radiated emission test-up frequency below 30MHz

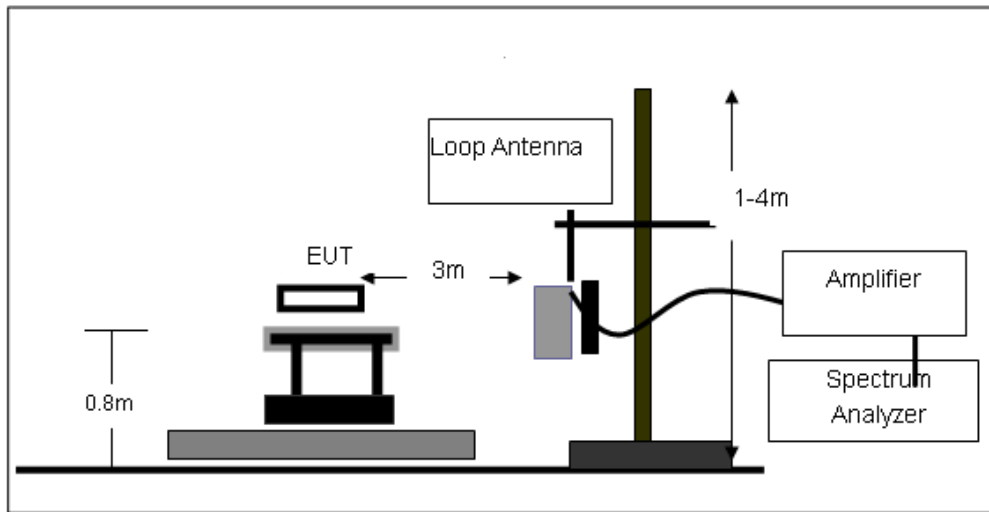

Radiated emission test-up frequency 30MHz~1GHz

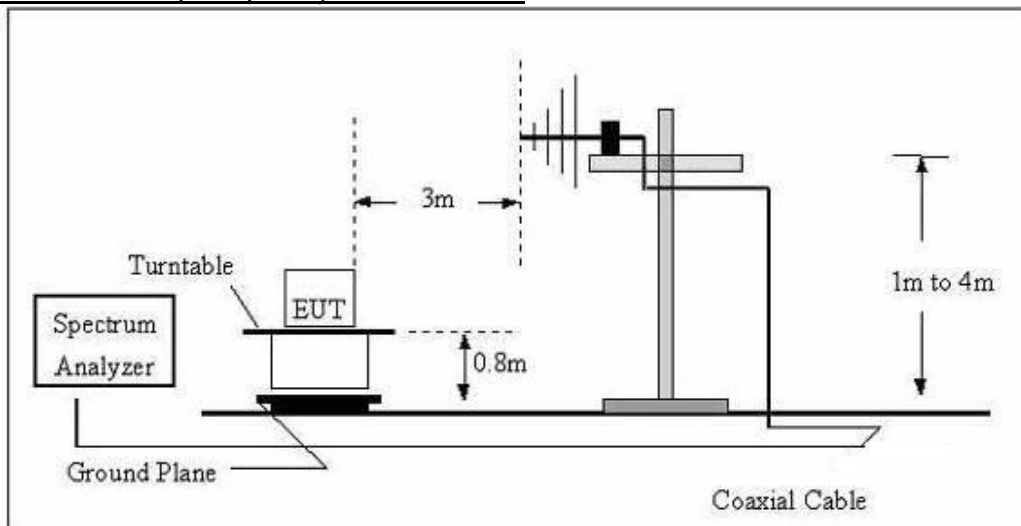

Radiated emission test-up frequency above 1GHz

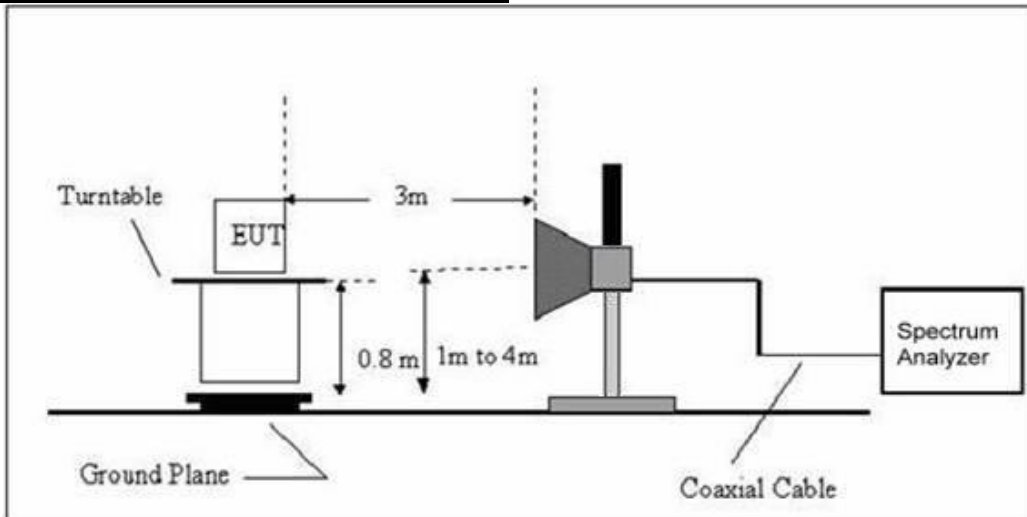

5.4.3 Test procedure

- a. EUT operating conditions. The EUT tested system was configured as the statements of 2.4 Unless otherwise a special operating condition is specified in the follows during the testing.
- b. The measuring distance of at 3 m shall be used for measurements at frequency up to 1GHz. For frequencies above 1GHz, any suitable measuring distance may be used.
- c. The EUT was placed on the top of a rotating table 0.8 meters above the ground at a 3 meter open area test site. The table was rotated 360 degrees to determine the position of the highest radiation.
- d. The height of the equipment or of the substitution antenna shall be 0.8 m; the height of the test antenna shall vary between 1 m to 4 m. Both horizontal and vertical polarizations of the antenna are set to make the measurement.
- e. The initial step in collecting conducted emission data is a spectrum analyzer peak detector mode pre-scanning the measurement frequency range. Significant peaks are then marked and then Quasi Peak detector mode re-measured.
- f. If the Peak Mode measured value compliance with and lower than Quasi Peak Mode Limit, the EUT shall be deemed to meet QP Limits and then no additional QP Mode measurement performed.
- g. For the actual test configuration, please refer to the related Item –EUT Test photos.

Note: Both horizontal and vertical antenna polarities were tested and performed pretest to three orthogonal axis. The worst case emissions were reported

5.4.4 Test results

5.4.4.1 Radiation emission

Below 30MHz

EUT:	String Light Speaker	Model Name:	VSS60014BT-FEX
Temperature:	20 °C	Relative Humidity:	48%
Pressure:	1010 hPa	Test Voltage:	DC 5V from adapter AC 120V/60Hz AC 120V/60Hz
Test Mode:	TX	Polarization :	--

Freq.	Reading	Limit	Margin	State
(MHz)	(dBuV/m)	(dBuV/m)	(dB)	P/F
--	--	--	--	Pass
--	--	--	--	Pass

Note:

The amplitude of spurious emissions which are attenuated by more than 20dB below the permissible value has no need to be reported.

Distance extrapolation factor = $40 \log(\text{specific distance}/\text{test distance})$ (dB);

Limit line = specific limits(dBuV) + distance extrapolation factor.

Between 30MHz – 1GHz

EUT :	String Light Speaker	Model Name. :	VSS60014BT-FEX
Temperature :	26 °C	Relative Humidity :	54%
Pressure :	1010hPa	Phase :	H
Test Voltage :	DC 5V from adapter AC 120V/60Hz AC 120V/60Hz	Test Mode :	TX Mode

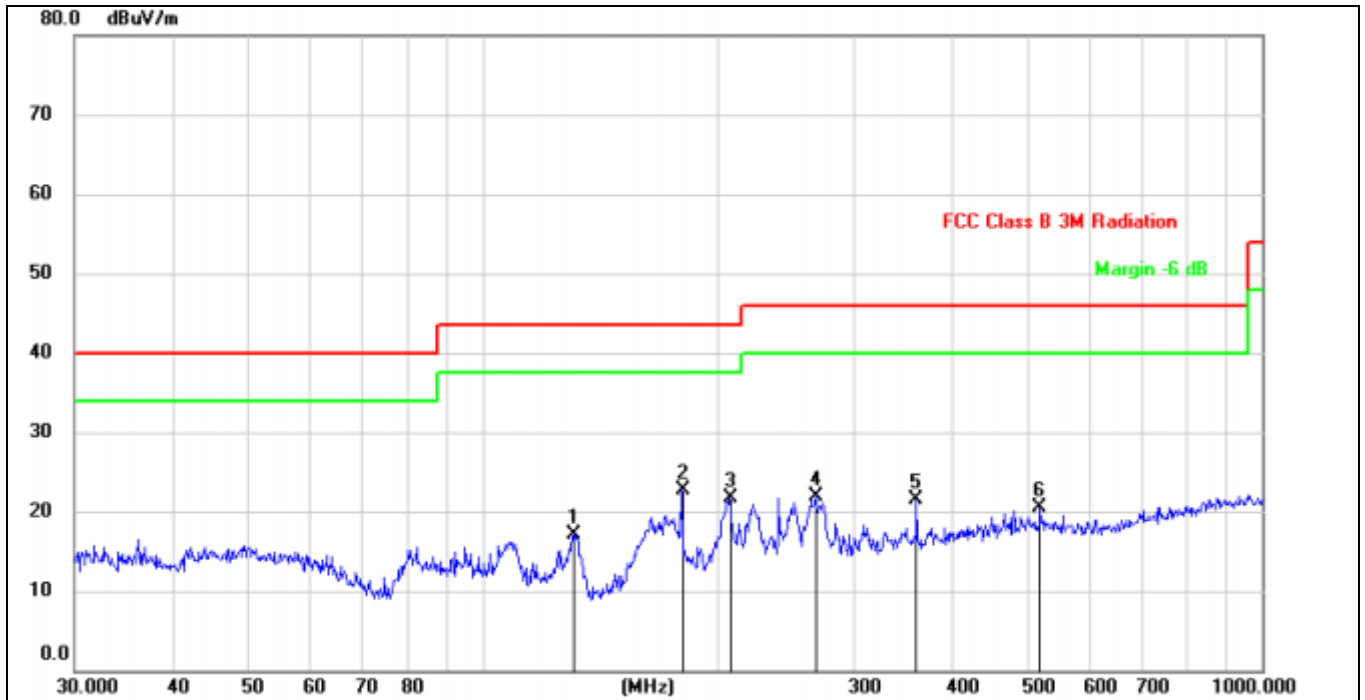

No.	Mk.	Freq.	Reading Level	Correct Factor	Measurement	Limit	Over	Antenna Height	Table Degree	
		MHz	dBuV	dBuV/m	dBuV/m	dBuV/m	dB	cm	degree	Comment
1		131.2965	32.23	-15.03	17.20	43.50	-26.30	QP		
2	*	180.0165	38.22	-15.42	22.80	43.50	-20.70	QP		
3		207.1226	34.28	-12.58	21.70	43.50	-21.80	QP		
4		267.5455	32.88	-10.88	22.00	46.00	-24.00	QP		
5		360.4476	30.59	-9.09	21.50	46.00	-24.50	QP		
6		519.0648	27.97	-7.47	20.50	46.00	-25.50	QP		

EUT :	String Light Speaker	Model Name. :	VSS60014BT-FEX
Temperature :	26 °C	Relative Humidity :	54%
Pressure :	1010hPa	Phase :	V
Test Voltage :	DC 5V from adapter AC 120V/60Hz AC 120V/60Hz	Test Mode :	TX Mode

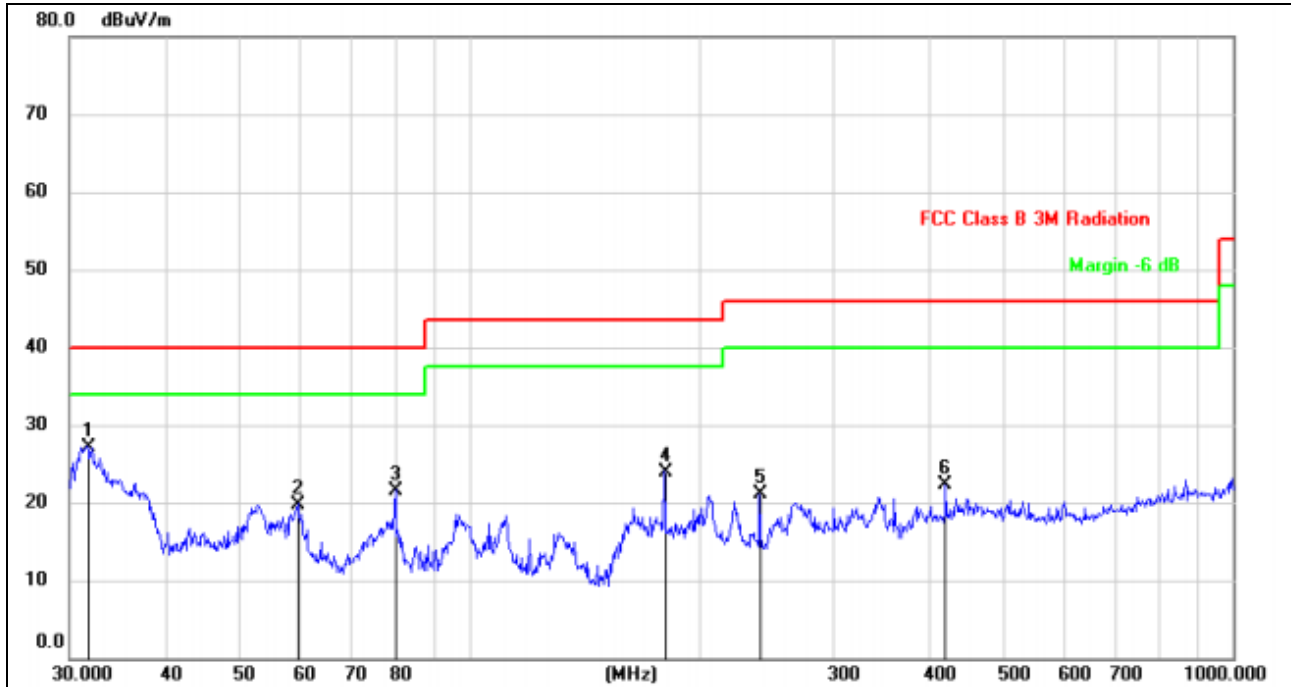

No.	Mk.	Freq.	Reading Level	Correct Factor	Measurement	Limit	Over	Antenna Height	Table Degree
		MHz	dBuV	dBuV/m	dBuV/m	dBuV/m	dB	cm	degree
1	*	31.6202	38.80	-11.60	27.20	40.00	-12.80	QP	
2		59.6493	31.18	-11.38	19.80	40.00	-20.20	QP	
3		80.0806	36.45	-14.85	21.60	40.00	-18.40	QP	
4		180.0165	36.42	-12.42	24.00	43.50	-19.50	QP	
5		239.9874	32.70	-11.60	21.10	46.00	-24.90	QP	
6		420.5803	30.51	-8.21	22.30	46.00	-23.70	QP	

1G-25GHz

GFSK

Normal Voltage

Polar (H/V)	Frequency	Meter Reading	Factor	Emission Level	Limits	Margin	Detector Type
	(MHz)	(dBuV)	(dB)	(dBuV/m)	(dBuV/m)	(dB)	
Low Channel (2402 MHz)							
Vertical	4137.250	53.15	-5.04	48.11	74	-25.89	Peak
Horizontal	4008.000	51.05	-2.67	48.38	74	-25.62	Peak
Vertical	6663.500	51.88	-5.54	46.34	74	-27.66	Peak
Horizontal	6675.250	50.50	-3.90	46.60	74	-27.40	Peak
Vertical	7262.750	51.98	-4.51	47.47	74	-26.53	Peak
Vertical	9977.000	51.31	-0.26	51.05	74	-22.95	Peak
Vertical	11351.750	51.18	0.37	51.55	74	-22.45	Peak
Horizontal	8038.250	49.25	-1.87	47.38	74	-26.62	Peak
Horizontal	8872.500	49.79	-1.15	48.64	74	-25.36	Peak
Horizontal	10846.500	49.21	2.30	51.51	74	-22.49	Peak
Mid Channel (2441 MHz)							
Vertical	3752.88	53.77	-5.57	48.20	74.00	-25.8	Peak
Horizontal	3991.52	50.77	-2.78	47.99	74.00	-26.01	Peak
Vertical	6418.13	51.48	-6.35	45.13	74.00	-28.87	Peak
Horizontal	6618.11	50.59	-4.20	46.39	74.00	-27.61	Peak
Vertical	7453.26	51.33	-4.73	46.60	74.00	-27.4	Peak
Vertical	9891.89	49.47	-0.62	48.85	74.00	-25.15	Peak
Vertical	10568.70	51.29	-0.24	51.05	74.00	-22.95	Peak
Horizontal	7219.62	49.78	-3.08	46.70	74.00	-27.3	Peak
Horizontal	9631.64	49.58	0.34	49.92	74.00	-24.08	Peak
Horizontal	11382.73	49.05	2.10	51.15	74.00	-22.85	Peak
High Channel (2480 MHz)							
Vertical	3749.500	53.37	-5.12	48.25	74.00	-25.75	Peak
Horizontal	3984.500	50.93	-2.68	48.25	74.00	-25.75	Peak
Vertical	6416.750	51.57	-6.18	45.39	74.00	-28.61	Peak
Horizontal	6616.500	50.51	-4.09	46.42	74.00	-27.58	Peak
Vertical	7450.750	51.27	-4.32	46.95	74.00	-27.05	Peak
Vertical	9883.000	49.64	-0.46	49.18	74.00	-24.82	Peak
Vertical	10564.500	50.84	0.22	51.06	74.00	-22.94	Peak
Horizontal	7215.750	49.77	-2.82	46.95	74.00	-27.05	Peak
Horizontal	9624.500	49.52	0.74	50.26	74.00	-23.74	Peak
Horizontal	11375.250	48.79	2.45	51.24	74.00	-22.76	Peak

Note1 : Absolute Level = Reading Level+ Factor, Margin= Absolute Level- Limit, Factor = Antenna Factor + Cable Loss – Pre-amplifier.

Note2 :The peak value is less than the AV value, AV value is not required Factor added by measurement software automatically.

π /4-DQPSK

Normal Voltage

Polar (H/V)	Frequency	Meter Reading	Factor	Emission Level	Limits	Margin	Detector Type
	(MHz)	(dBuV)	(dB)	(dBuV/m)	(dBuV/m)	(dB)	
Low Channel (2402 MHz)							
Vertical	3726.000	53.27	-5.20	48.07	74.00	-25.93	Peak
Horizontal	4219.500	50.80	-3.86	46.94	74.00	29.66	Peak
Vertical	5758.750	60.06	-8.31	51.75	74.00	-22.25	Peak
Horizontal	6334.500	50.41	-4.85	45.56	74.00	-28.44	Peak
Vertical	7979.500	50.48	-3.68	46.80	74.00	-27.20	Peak
Vertical	9859.500	50.29	-0.52	49.77	74.00	-24.23	Peak
Vertical	11528.000	51.13	0.37	51.50	74.00	-22.50	Peak
Horizontal	7815.000	48.88	-2.18	46.70	74.00	-27.30	Peak
Horizontal	10059.250	47.77	1.93	49.70	74.00	-24.30	Peak
Horizontal	11704.250	48.26	2.47	50.73	74.00	-23.27	Peak
Mid Channel (2441 MHz)							
Vertical	3729.000	52.94	-5.29	47.65	74	-26.35	Peak
Horizontal	4225.000	50.63	-4.06	46.57	74	-27.43	Peak
Vertical	5760.000	59.92	-8.40	51.52	74	-22.48	Peak
Horizontal	6343.000	50.35	-5.01	45.34	74	-28.66	Peak
Vertical	7985.000	50.37	-3.84	46.53	74	-27.47	Peak
Vertical	9863.000	50.4	-0.80	49.60	74	-24.4	Peak
Vertical	11536.00	51.34	0.02	51.36	74	-22.64	Peak
Horizontal	7816.000	48.78	-2.26	46.52	74	-27.48	Peak
Horizontal	10063.00	47.63	1.72	49.35	74	-24.65	Peak
Horizontal	11708.00	48.16	2.36	50.52	74	-23.48	Peak
High Channel (2480 MHz)							
Vertical	3749.500	53.37	-5.12	48.25	74.00	-25.75	Peak
Horizontal	3984.500	50.93	-2.68	48.25	74.00	-25.75	Peak
Vertical	6416.750	51.57	-6.18	45.39	74.00	-28.61	Peak
Horizontal	6616.500	50.51	-4.09	46.42	74.00	-27.58	Peak
Vertical	7450.750	51.27	-4.32	46.95	74.00	-27.05	Peak
Vertical	9883.000	49.64	-0.46	49.18	74.00	-24.82	Peak
Vertical	10564.500	50.84	0.22	51.06	74.00	-22.94	Peak
Horizontal	7215.750	49.77	-2.82	46.95	74.00	-27.05	Peak
Horizontal	9624.500	49.52	0.74	50.26	74.00	-23.74	Peak
Horizontal	11375.250	48.79	2.45	51.24	74.00	-22.76	Peak

Note1 : Absolute Level = Reading Level+ Factor, Margin= Absolute Level- Limit, Factor = Antenna Factor + Cable Loss – Pre-amplifier.

Note2 :The peak value is less than the AV value, AV value is not required Factor added by measurement software automatically.

5.4.4.2 Band edge - radiated

Frequency (MHz)	Meter Reading (dBμV)	Factor (dB)	Emission Level (dBμV/m)	Limits (dBμV/m)	Margin (dB)	Detector Type	Comment
GFSK							
2390	56.65	-9.65	47	74.00	-27	peak	Vertical
2390	55.05	-8.62	46.43	74.00	-27.57	peak	Horizontal
2400	56.58	-10.31	46.27	74.00	-27.73	peak	Vertical
2400	53.29	-9.43	43.86	74.00	-30.14	peak	Horizontal
2483.5	59.41	-8.66	50.75	74.00	-23.25	peak	Vertical
2483.5	58.79	-9.73	49.06	74.00	-24.94	peak	Horizontal
π/4-DQPSK							
2390	57.40	-10.33	47.07	74.00	-26.93	peak	Vertical
2390	54.26	-9.45	44.81	74.00	-29.19	peak	Horizontal
2400	55.80	-10.31	45.49	74.00	-28.51	peak	Vertical
2400	58.80	-9.43	49.37	74.00	-24.63	peak	Horizontal
2483.5	53.95	-9.73	44.22	74.00	-29.78	peak	Vertical
2483.5	53.98	-8.66	45.32	74.00	-28.68	peak	Horizontal

Note1 : Absolute Level = Reading Level+ Factor, Margin= Absolute Level- Limit, Factor = Antenna Factor + Cable Loss – Pre-amplifier.

Note2 :The peak value is less than the AV value, AV value is not required Factor added by measurement software automatically.

5.5 20dB occupied channel bandwidth

5.5.1 Limit

FCC Part15 (15.247) , Subpart C			
Section	Test Item	Limit	Frequency Range (MHz)
15.247a(1)	20dB bandwidth	/	2400-2483.5

5.5.2 Test setup



5.5.3 Test procedure

- (1) The EUT was directly connected to the spectrum analyzer and antenna output port as show in the block diagram above.
- (2) Spectrum Setting:
Bandwidth: RBW=30 kHz, VBW=100 kHz, detector= Peak

5.5.4 EUT Operation Conditions

The EUT tested system was configured as the statements of 2.1 Unless otherwise a special operating condition is specified in the follows during the testing.

5.5.5 Test results

Test data

GFSK mode:

EUT :	String Light Speaker	Model Name :	VSS60014BT-FEX
Temperature :	25 °C	Relative Humidity :	60%
Pressure :	1012 hPa	Test Voltage :	DC 5V from adapter AC 120V/60Hz

Channel	Frequency (MHz)	20dB Bandwidth (MHz)	Limit (kHz)	Result
Low	2402	0.8806	/	Pass
Middle	2441	0.8783	/	Pass
High	2480	0.8795	/	Pass

π /4-DQPSK mode:

EUT :	String Light Speaker	Model Name :	VSS60014BT-FEX
Temperature :	25 °C	Relative Humidity :	60%
Pressure :	1012 hPa	Test Voltage :	DC 5V from adapter AC 120V/60Hz

Channel	Frequency (MHz)	20dB Bandwidth (MHz)	Limit (kHz)	Result
Low	2402	1.254	/	Pass
Middle	2441	1.255	/	Pass
High	2480	1.259	/	Pass

Test plots

GFSK mode

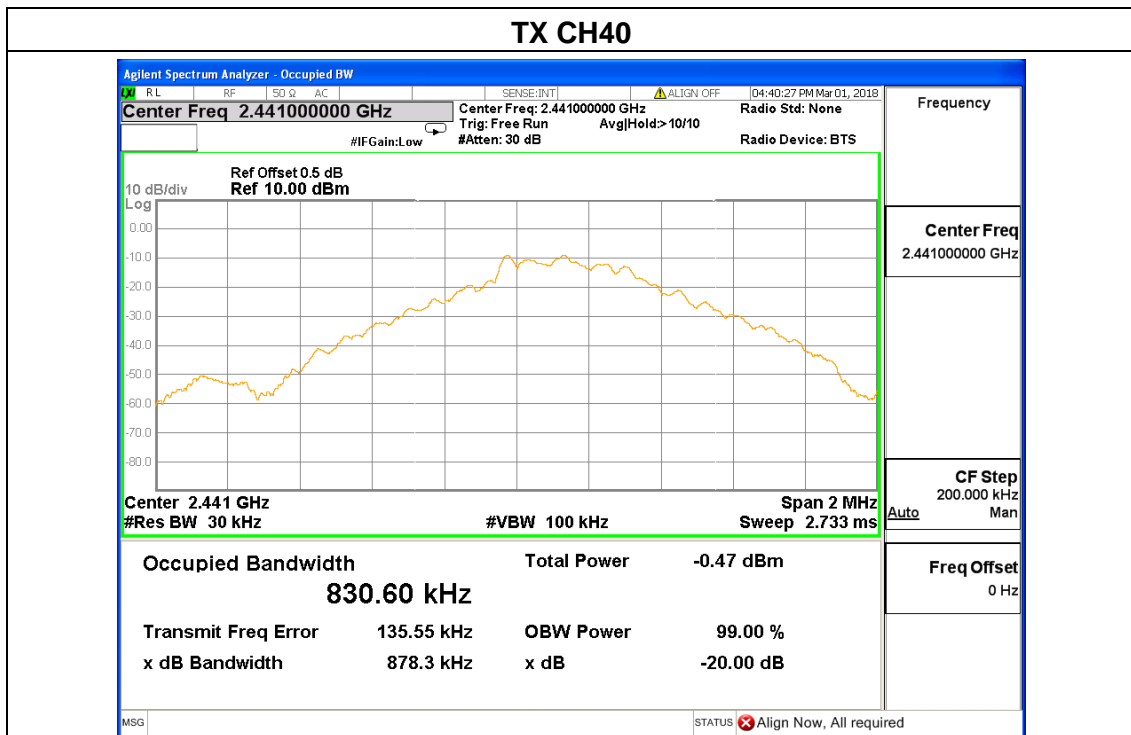
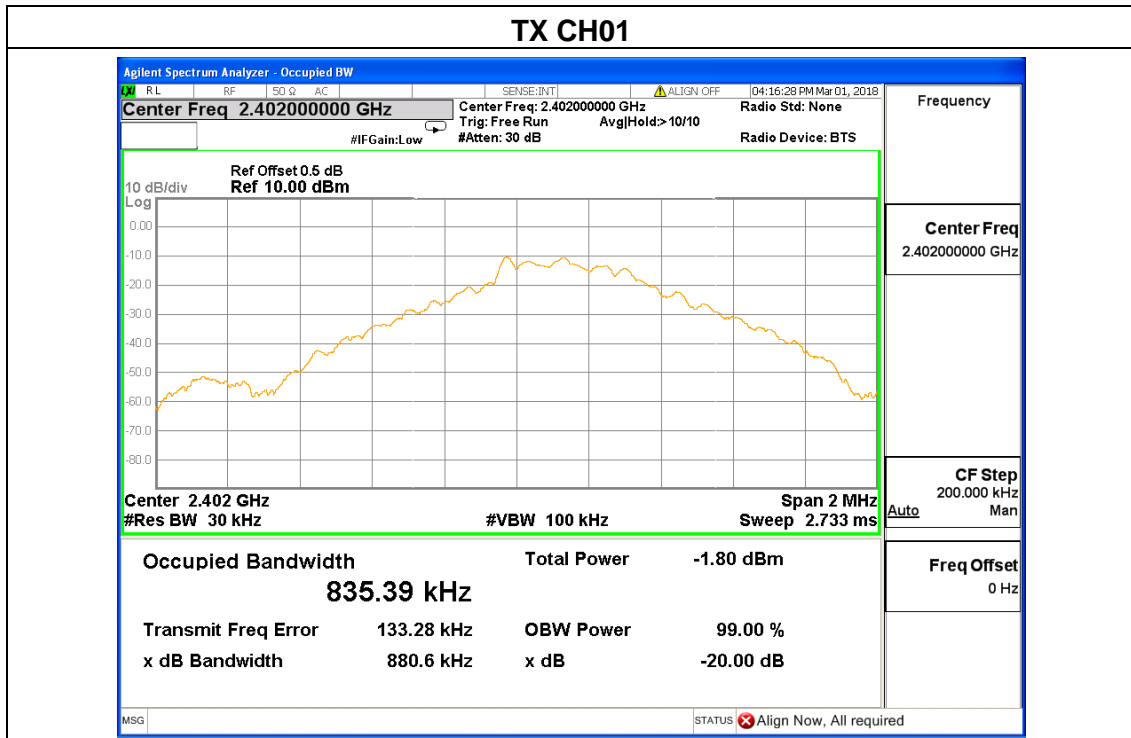

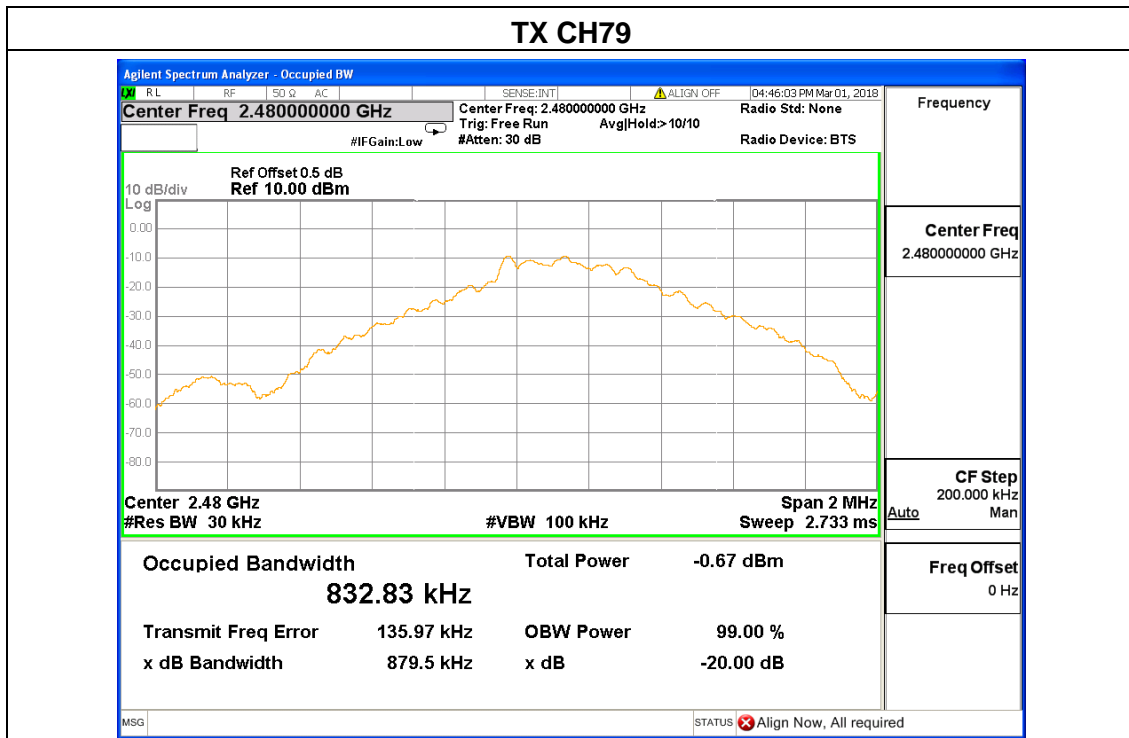

π /4-DQPSK mode

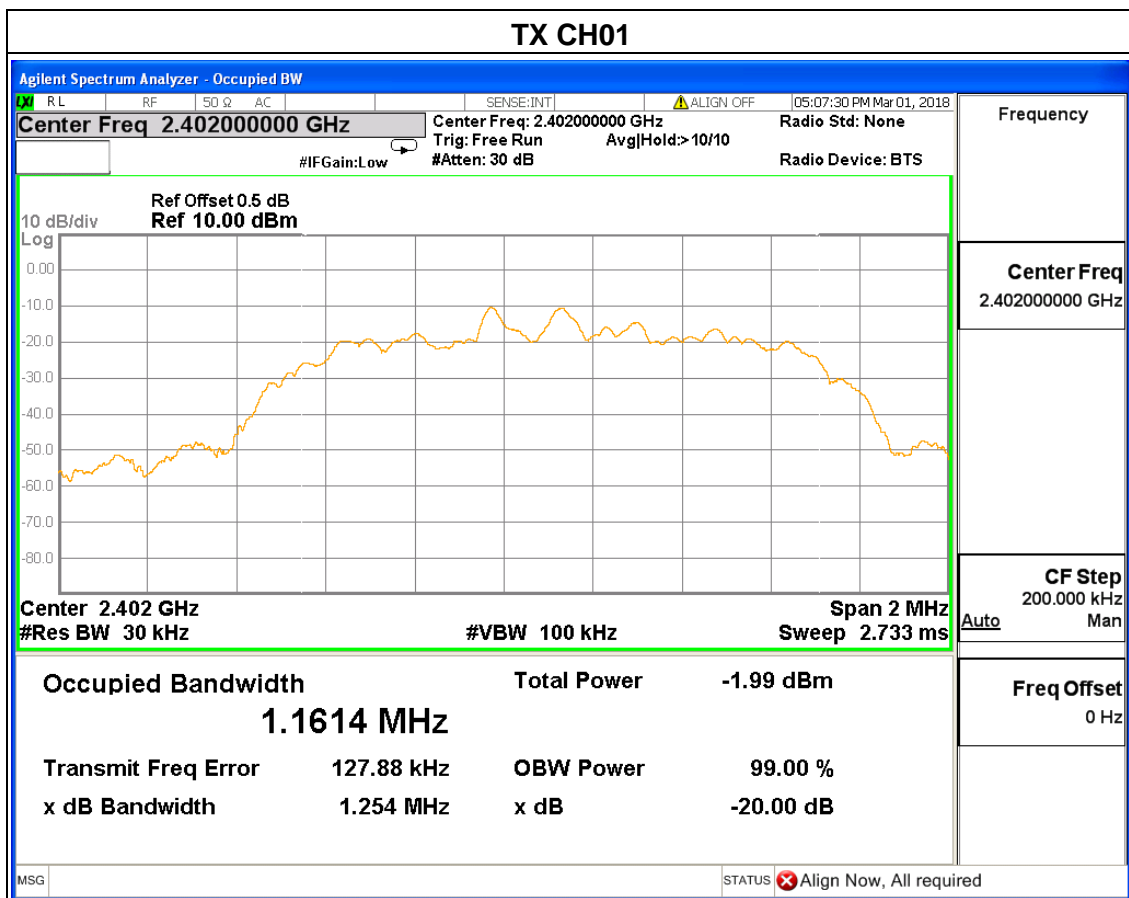

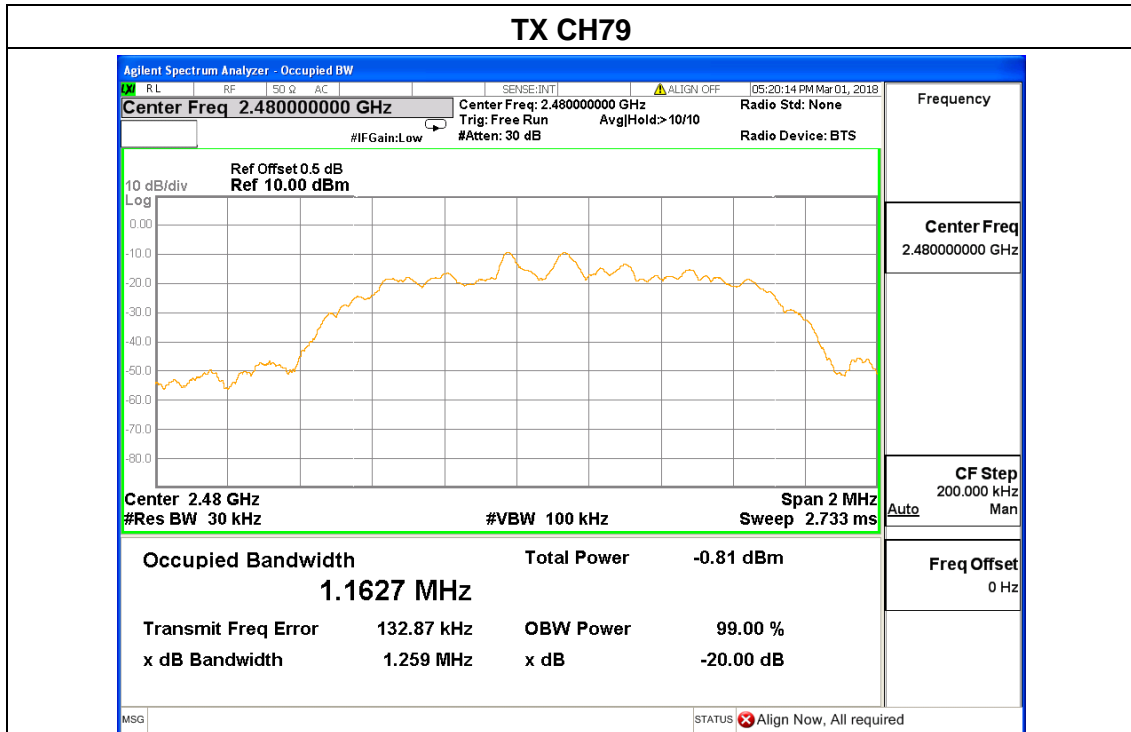
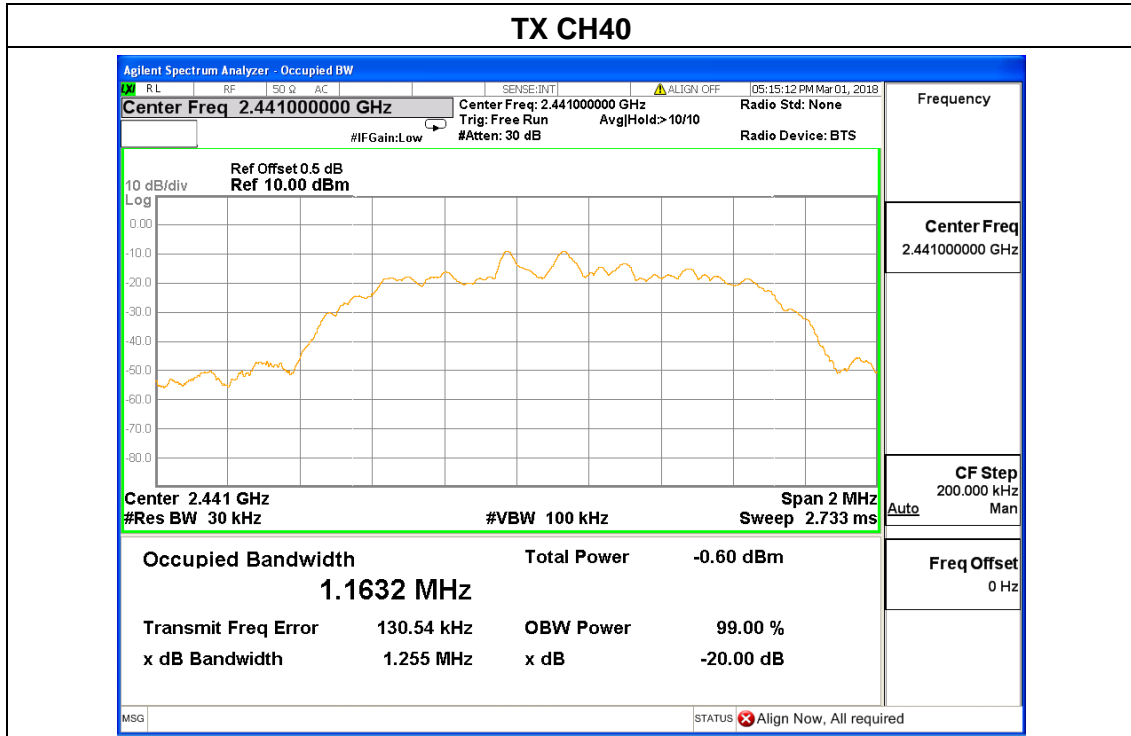

5.6 Band edge - Conducted

5.6.1 Limit

In any 100 kHz bandwidth outside the frequency band in which the spread spectrum or digitally modulated intentional radiator is operating, the radio frequency power that is produced by the intentional radiator shall be at least 20 dB below that in the 100 kHz bandwidth within the band that contains the highest level of the desired power, based on either an RF conducted or a radiated measurement, provided the transmitter demonstrates compliance with the peak conducted power limits. If the transmitter complies with the conducted power limits based on the use of RMS averaging over a time interval, as permitted under paragraph (b)(3) of this section, the attenuation required under this paragraph shall be 30 dB instead of 20 dB. Attenuation below the general limits specified in §15.209(a) is not required. In addition, radiated emissions which fall in the restricted bands, as defined in §15.205(a), must also comply with the radiated emission limits specified in §15.209(a) (see §15.205(c)).

5.6.2 Test setup



5.6.3 Test procedure

- a) Check the calibration of the measuring instrument using either an internal calibrator or a known signal from an external generator.
- b) Position the EUT without connection to measurement instrument. Turn on the EUT and connect its antenna terminal to measurement instrument via a low loss cable. Then set it to any one measured frequency within its operating range, and make sure the instrument is operated in its linear range.
- c) Set RBW to 100 kHz and VBW of spectrum analyzer to 300 kHz with a convenient frequency span including 100 kHz bandwidth from band edge.
- d) Measure the highest amplitude appearing on spectral display and set it as a reference level. Plot the graph with marking the highest point and edge frequency.
- e) Repeat above procedures until all measured frequencies were complete.

5.6.4 EUT operation conditions

The EUT tested system was configured as the statements of 2.4 Unless otherwise a special operating condition is specified in the follows during the testing.

5.6.5 Test results

Test data

EUT :	String Light Speakerr	Model Name :	VSS60014BT-FEX
Temperature :	25 °C	Relative Humidity :	60%
Pressure :	1012 hPa	Test Voltage :	DC 5V from USB Port

Frequency Band	Delta Peak to band emission (dBc)	> Limit (dBc)	Result
GFSK mode			
Left-band	42.28	20	Pass
Right-band	45.06	20	Pass
$\pi/4$ -DQPSK mode			
Left-band	42.32	20	Pass
Right-band	46.03	20	Pass

Test plots

GFSK: Band Edge, Left Side

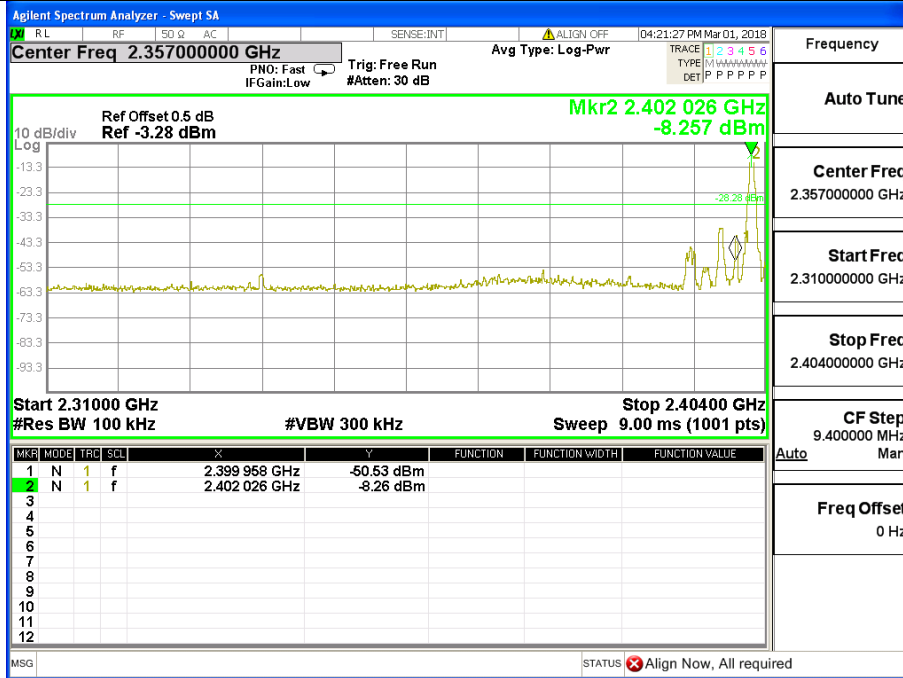

GFSK: Band Edge, Right Side

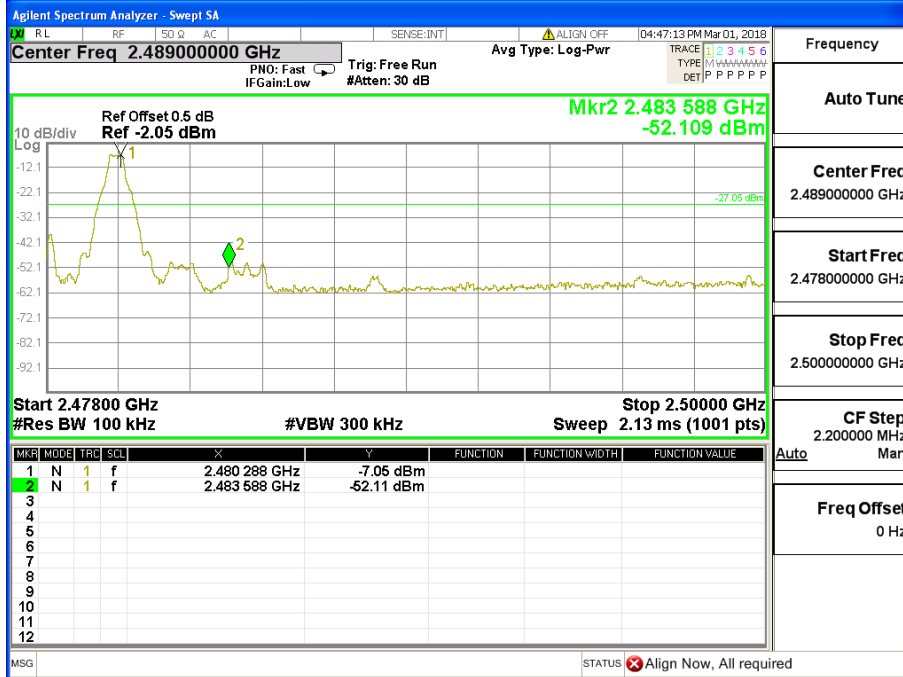

π /4-DQPSK: Band Edge, Left Side

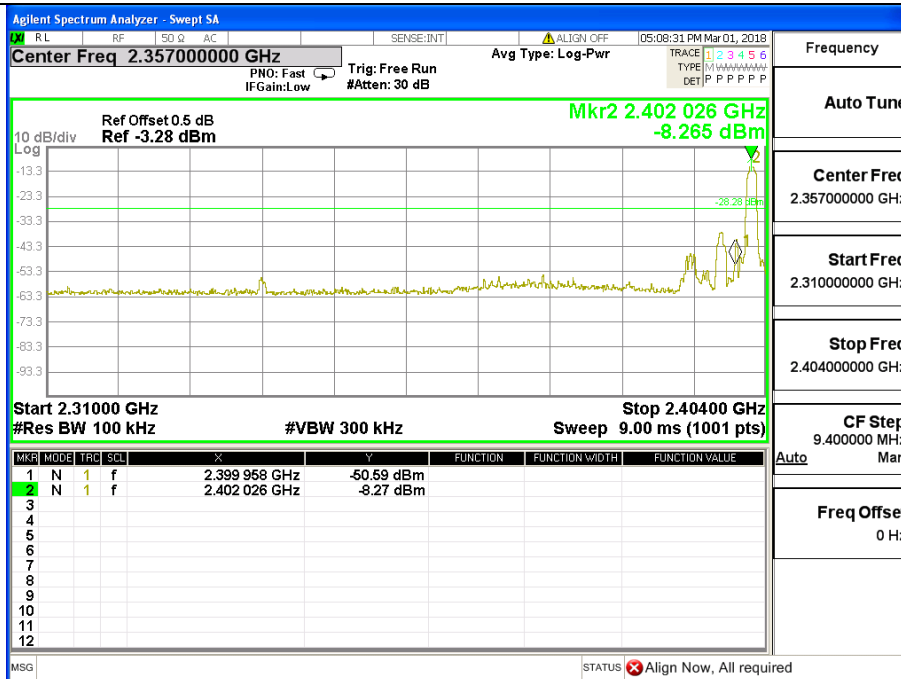

π /4-DQPSK: Band Edge, Right Side

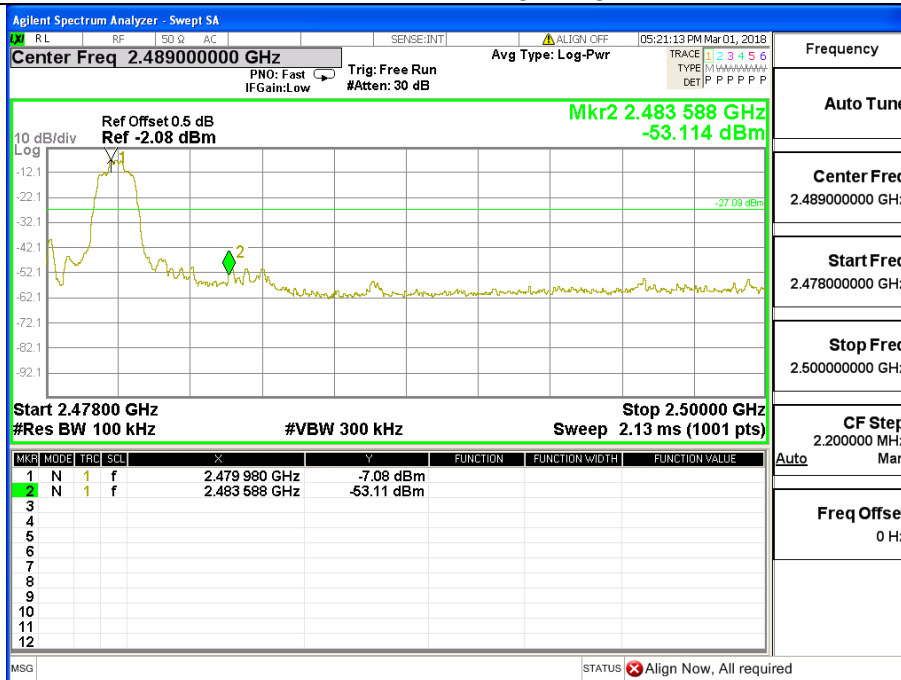

Hopping Mode

Frequency Band	Delta Peak to band emission (dBc)	> Limit (dBc)	Result
GFSK mode			
Left-band	28.74	20	Pass
Right-band	46.72	20	Pass
$\pi/4$ -DQPSK mode			
Left-band	31.53	20	Pass
Right-band	44.76	20	Pass

GFSK: Band Edge, Left Side

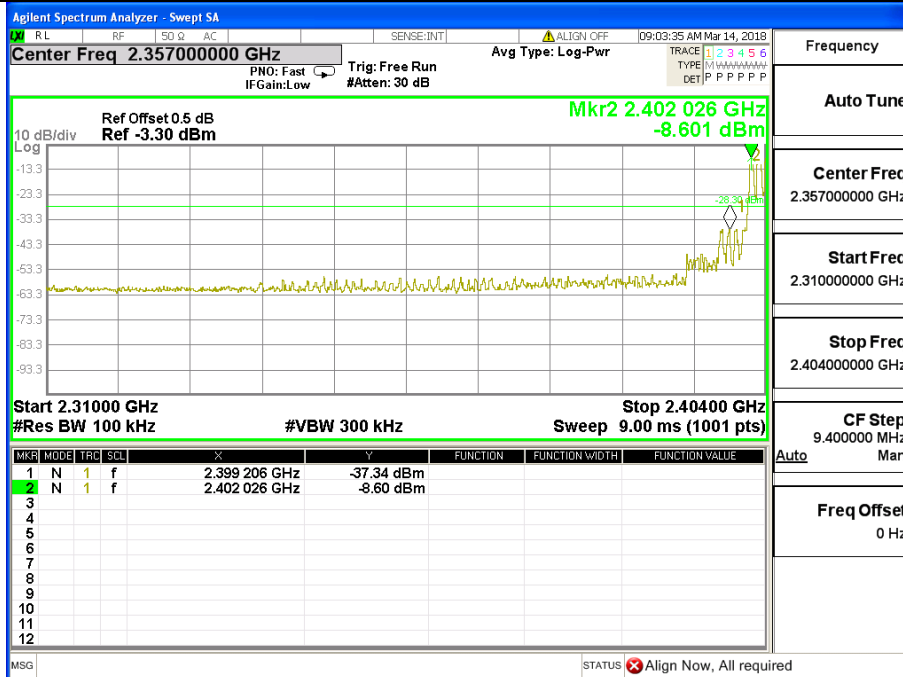

GFSK: Band Edge, Right Side

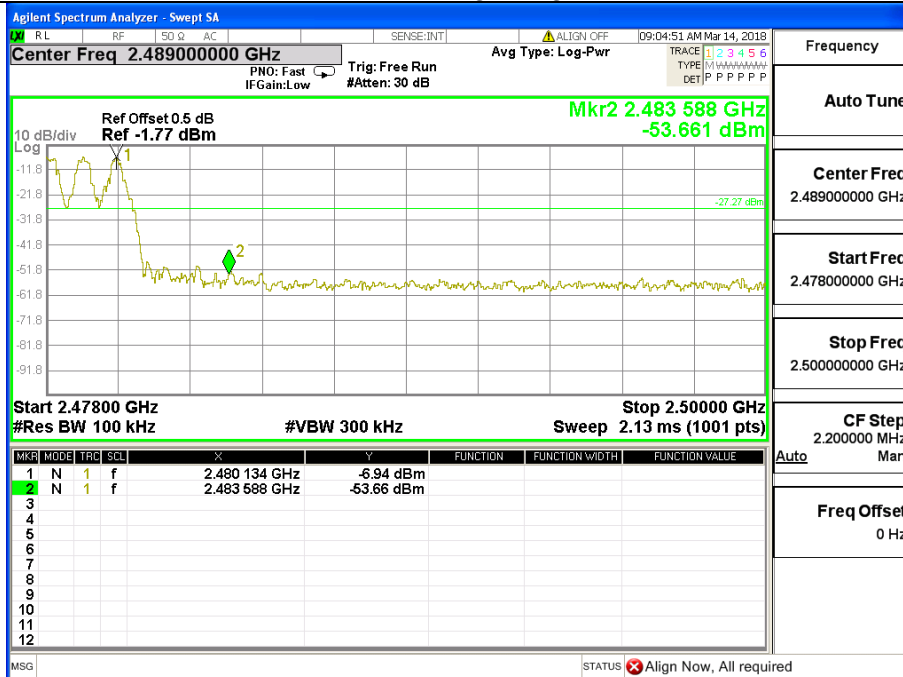

$\pi/4$ -DQPSK: Band Edge, Left Side

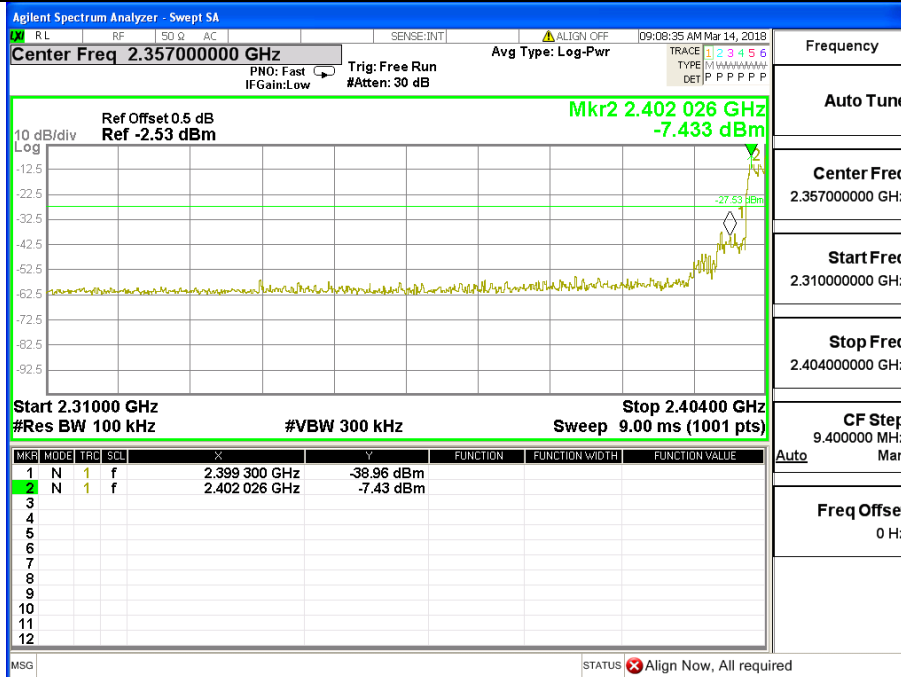

$\pi/4$ -DQPSK: Band Edge, Right Side

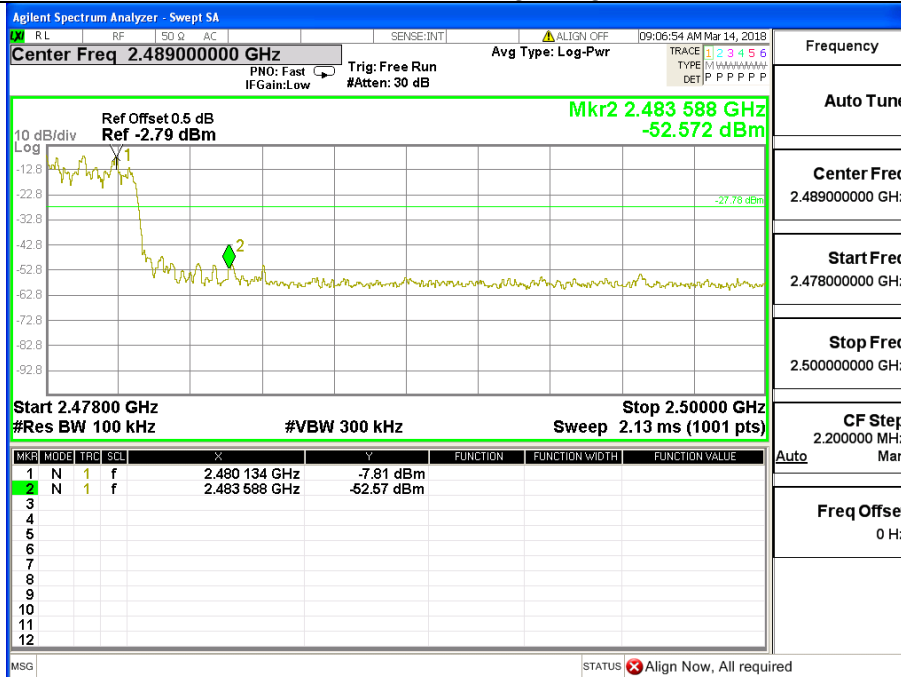

5.7 Carrier frequency separation

5.7.1 Limit

FCC Part15 (15.247) , Subpart C			
Section	Test Item	Limit	Frequency Range (MHz)
15.247(a)(1)	Channel Separation	>25KHz or >two-thirds of the 20 dB bandwidth (Which is greater)	2400-2483.5

5.7.2 Test setup



5.7.3 Test procedure

- (1) The EUT was directly connected to the spectrum analyzer and antenna output port as show in the block diagram above.
- (2) Spectrum Setting:
RBW=100 kHz, VBW=300 kHz, detector= Peak, Sweep Time =auto.
- (3) The EUT was set to the Hopping Mode for Channel Separation Test and continuously transmitting for the Test.

5.7.4 EUT operation conditions

The EUT tested system was configured as the statements of 2.1 Unless otherwise a special operating condition is specified in the follows during the testing.

5.7.5 Test results

Test data

EUT :	String Light Speakerr	Model Name :	VSS60014BT-FEX
Temperature :	25 °C	Relative Humidity :	60%
Pressure :	1012 hPa	Test Voltage :	DC 5V from USB Port
Test Mode :	GFSK Mode /CH00, CH39		

Mode	Channel	Frequency (MHz)	Test Result (KHz)	Limit (kHz)	Result
GFSK	Middle	2441	995	668	Pass
$\pi/4$ -DQPSK	Middle	2441	1064	668	Pass

Test plots

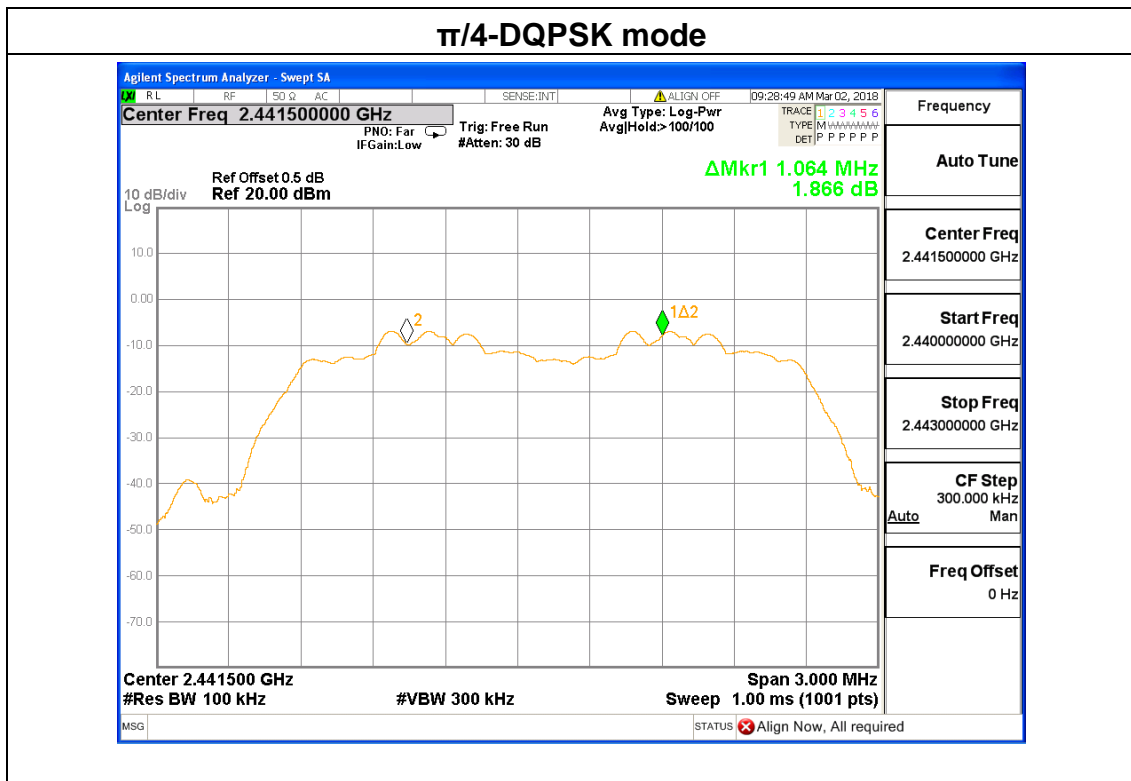
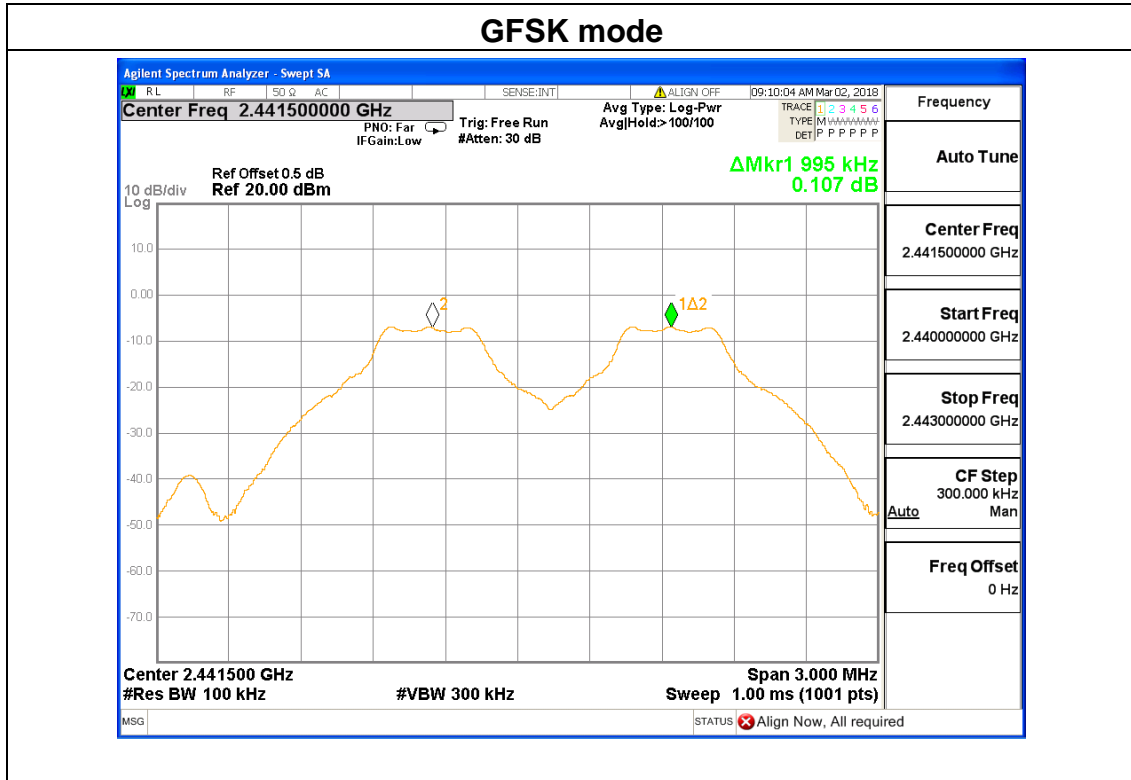

HOPPING CHANNEL

Mode	Quantity of Hopping Channel	Limit	Results
GFSK, $\pi/4$ -DQPSK	79	>15	Pass

Test plots

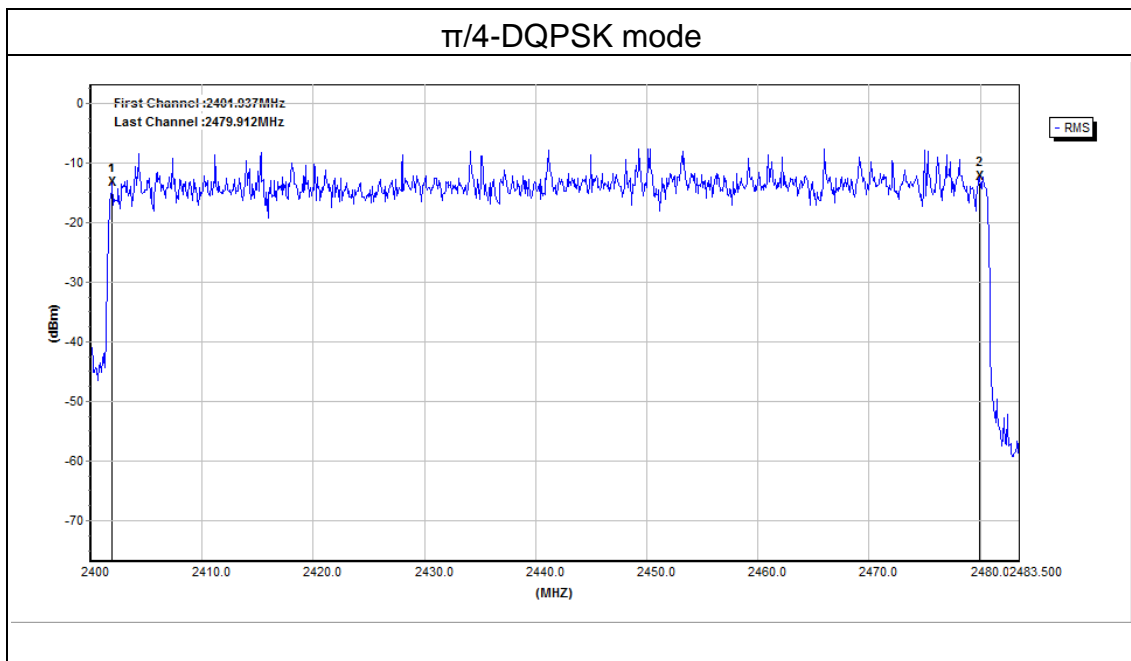
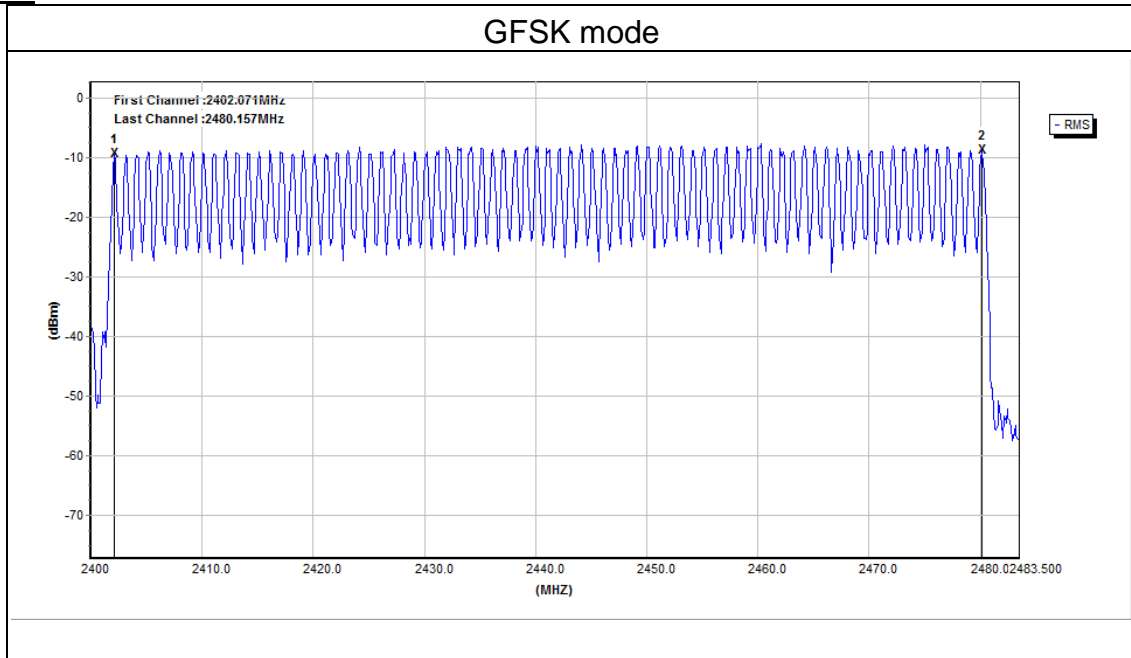

5.8 Dwell time

5.8.1 Limit

FCC Part15 (15.247) , Subpart C			
Section	Test Item	Limit	Frequency Range (MHz)
15.247(a)(a)	Dwell time	0.4 sec	2400-2483.5

5.8.2 Test setup

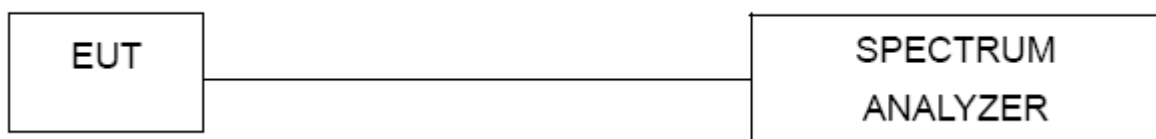

5.8.3 Test procedure

- (1) The EUT was directly connected to the spectrum analyzer and antenna output port as show in the block diagram above.
- (2) Spectrum Setting: RBW=1MHz, VBW=1MHz, Span=0Hz, Detector=Peak
- (3) Use video trigger with the trigger level set to enable triggering only on full pulses.
- (4) Sweep Time is more than once pulse time.
- (5) Set the center frequency on any frequency would be measure and set the frequency span to zero span.
- (6) Measure the maximum time duration of one single pulse.
- (7) Set the EUT for packet transmitting.
- (8) Measure the maximum time duration of one single pulse.
- (9) The EUT was set to the Hopping Mode for Dwell Time Test

5.8.4 EUT operation conditions

The EUT tested system was configured as the statements of 2.4 Unless otherwise a special operating condition is specified in the follows during the testing.

5.8.5 Test results

Test data

EUT :	String Light Speakerr	Model Name :	VSS60014BT-FEX
Temperature :	25 °C	Relative Humidity :	60%
Pressure :	1012 hPa	Test Voltage :	DC 5V from USB Port
Test Mode :	GFSK, $\pi/4$ -DQPSK,/ CH00, CH39		

Mode	Data Packet	Frequency (MHz)	Pulse Duration (ms)	Dwell Time (ms)	Limit(s)	Conclusion
GFSK	DH1	2441	0.38	121.60	<0.4	Pass
	DH3	2441	1.64	262.40	<0.4	Pass
	DH5	2441	2.90	309.33	<0.4	Pass
$\pi/4$ DQPSK	2DH1	2441	0.40	128.00	<0.4	Pass
	2DH3	2441	1.65	264.00	<0.4	Pass
	2DH5	2441	2.90	309.33	<0.4	Pass

Note1: A period time = 0.4 (s) * 79 = 31.6(s)

Note2:

DH1 time slot = Pulse Duration * (1600/(2*79)) * A period time

DH3 time slot = Pulse Duration * (1600/(4*79)) * A period time

DH5 time slot = Pulse Duration * (1600/(6*79)) * A period time

Note3: For GFSK, $\pi/4$ -DQPSK and $\pi/4$ -DQPSK: The test period: T= 0.4 Second/Channel x 79 Channel = 31.6 s

Test plots

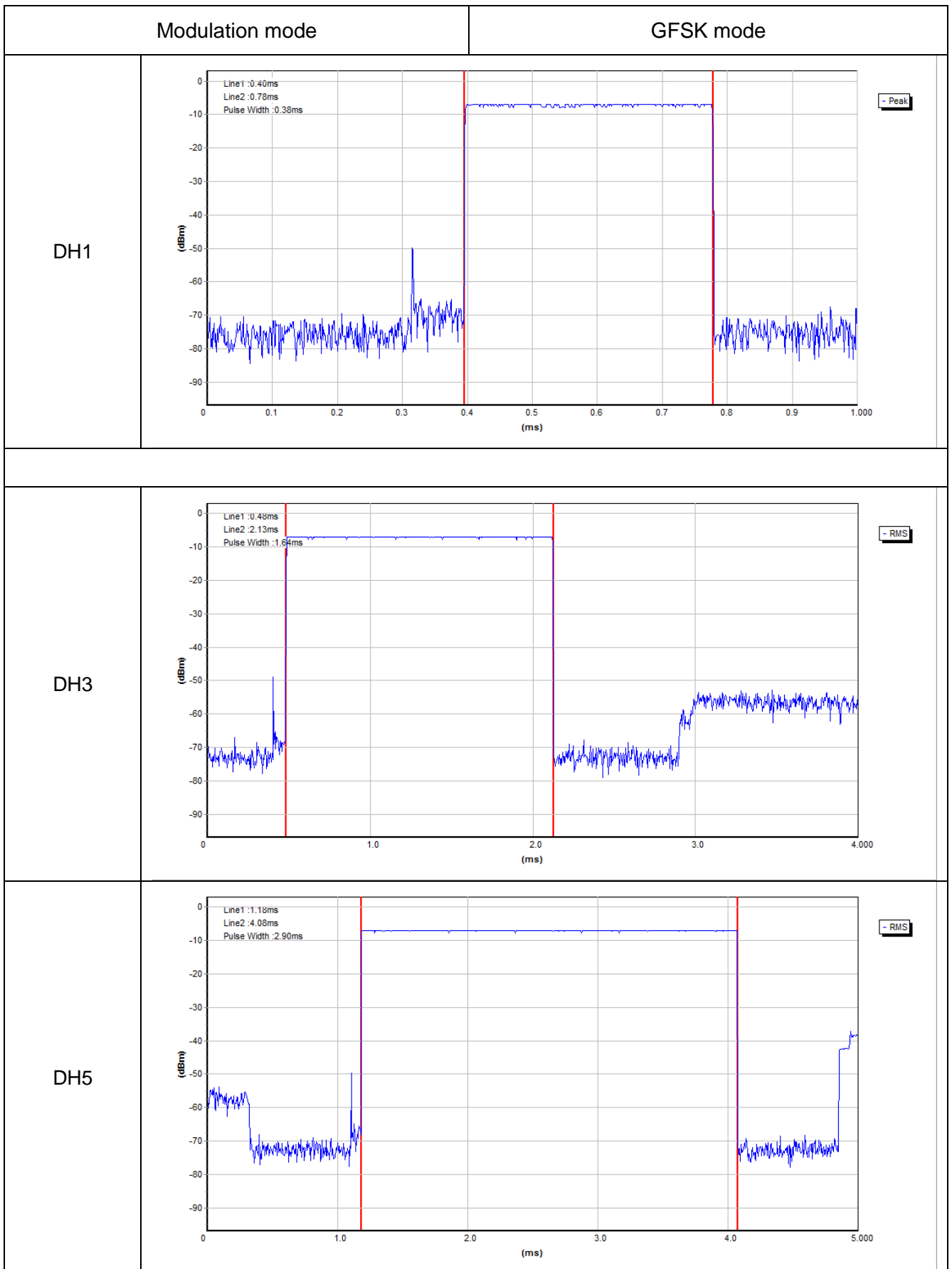

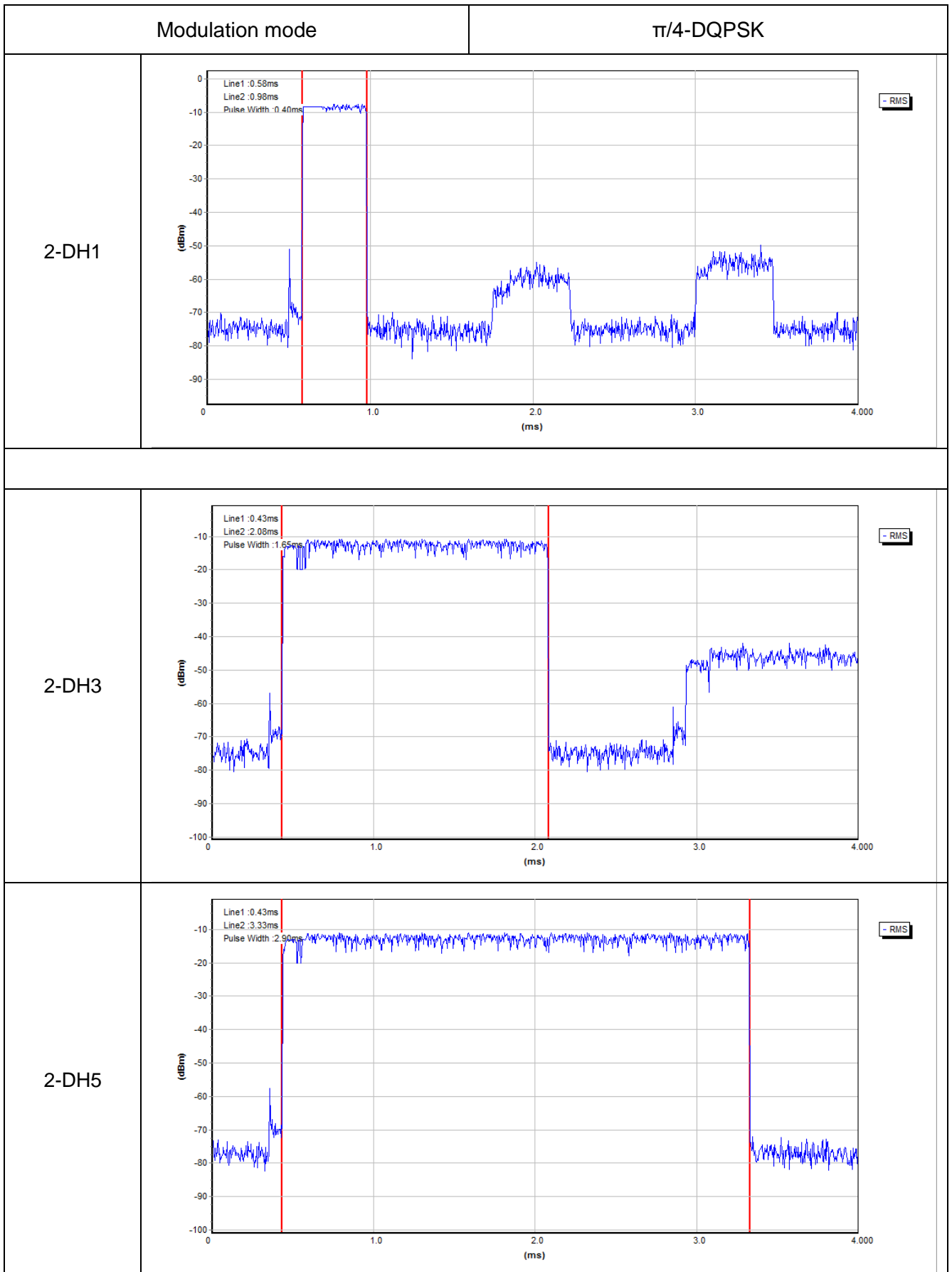

PHOTOGRAPHS OF THE TEST SETUP

Radiated emission – below 1GHz

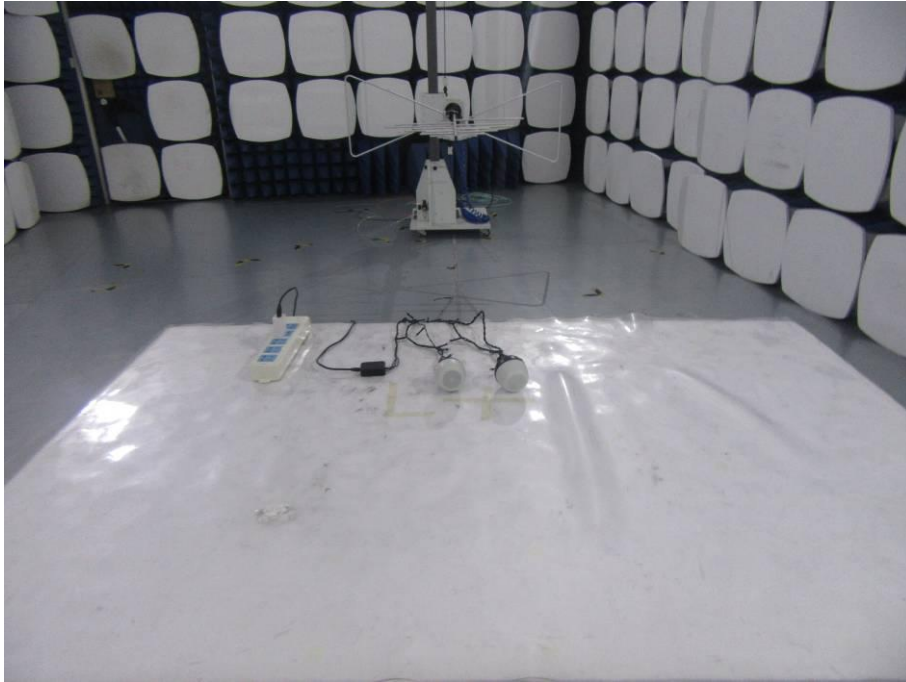

Radiated emission – above 1GHz

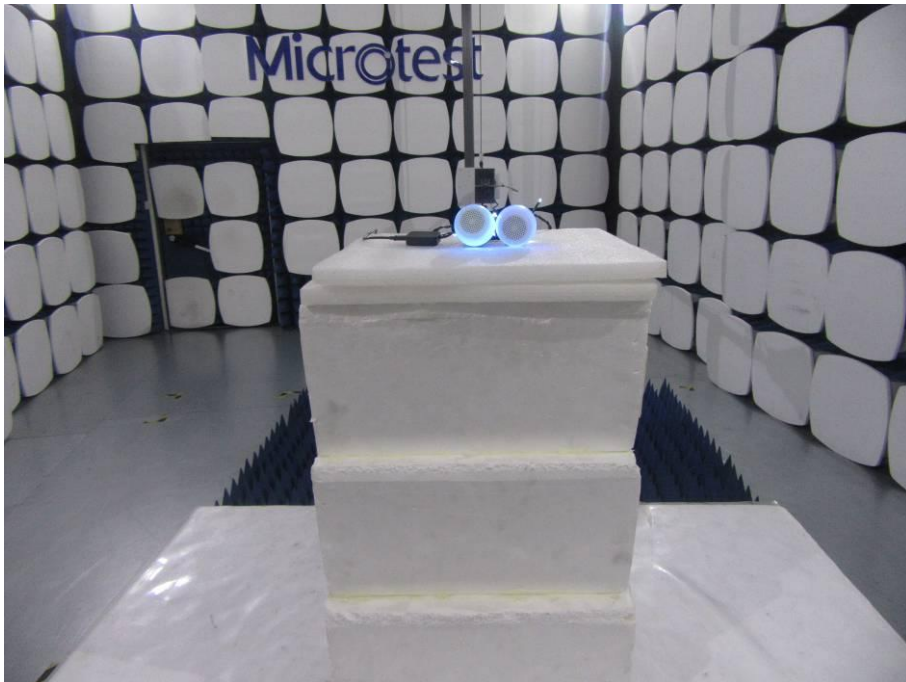

Conducted emission



---END OF REPORT---