

# Test Report

FCC ID: 2AG8N-17386

Date of issue: Sept. 21, 2018

Report Number:	MTi180920E121
Sample Description:	Q8 WIRELESS CHARGING PAD
Model(s):	QC0015, QC0015-CCK, QC0015-IV6, QC0015-GYS, E-QI-17386-A
Applicant:	China Etech Groups Ltd
Address:	Room 3A15, Floor4 ,Block C, Bao Yuan HuaFeng Headquater, Economy Building, Xixiang Road, Baoan District, Shenzhen
Date of Test:	Sept. 14, 2018 - Sept. 21, 2018

Shenzhen Microtest Co., Ltd.  
<http://www.mtitest.com>

## Table of Contents

<b>1</b>	<b>GENERAL INFORMATION</b>	<b>4</b>
1.1	FEATURE OF EQUIPMENT UNDER TEST (EUT)	4
1.2	TEST MODE	4
1.3	EUT TEST SETUP	4
1.4	ANCILLARY EQUIPMENT	4
1.5	MEASUREMENT UNCERTAINTY	5
<b>2</b>	<b>SUMMARY OF TEST RESULT</b>	<b>6</b>
<b>3</b>	<b>TEST FACILITIES AND ACCREDITATIONS</b>	<b>7</b>
3.1	TEST LABORATORY	7
3.2	ENVIRONMENTAL CONDITIONS	7
3.3	MEASUREMENT UNCERTAINTY	7
3.4	TEST SOFTWARE	7
<b>4</b>	<b>LIST OF TEST EQUIPMENT</b>	<b>8</b>
<b>5</b>	<b>TEST RESULTS</b>	<b>9</b>
5.1	CONDUCTED EMISSION	9
5.1.1	<i>Limits</i>	9
5.1.2	<i>Test Procedures</i>	9
5.1.3	<i>Test Setup</i>	9
5.1.4	<i>Test Result</i>	9
5.2	RADIATED EMISSION	14
5.2.1	<i>Limits</i>	14
5.2.2	<i>Test Procedures</i>	14
5.2.3	<i>Test Setup</i>	15
5.2.4	<i>Test Result</i>	16
	<b>PHOTOGRAPHS OF THE TEST SETUP</b>	<b>19</b>
	<b>PHOTOGRAPHS OF THE EUT</b>	<b>21</b>

## Test Result Certification

Applicant's name: China Etech Groups Ltd

Address: Room 3A15, Floor4 ,Block C, Bao Yuan HuaFeng Headquater, Economy Building, Xixiang Road, Baoan District, Shenzhen

Manufacture's name: China Etech Groups Ltd

Address: Room 3A15, Floor4 ,Block C, Bao Yuan HuaFeng Headquater, Economy Building, Xixiang Road, Baoan District, Shenzhen

Product name: Q8 WIRELESS CHARGING PAD

Trademark: N/A

Model name: QC0015, QC0015-CCK, QC0015-IV6, QC0015-GYS, E-QI-17386-A

Standards: FCC Part 18

Test Procedure: ANSI C63.4-2014  
FCC/OST MP-5:1986

*This device described above has been tested by Shenzhen Microtest Co., Ltd. and the test results show that the equipment under test (EUT) is in compliance with the FCC requirements. And it is applicable only to the tested sample identified in the report.*

Tested by:

Leo Su

Leo Su

Sept. 21, 2018

Reviewed by:

Blue Zheng

Blue Zheng

Sept. 21, 2018

Approved by:

Smith Chen

Smith Chen

Sept. 21, 2018

## 1 GENERAL INFORMATION

### 1.1 Feature of equipment under test (EUT)

Product name:	Q8 WIRELESS CHARGING PAD
Brand name:	N/A
Model name:	QC0015
Series model:	QC0015-CCK, QC0015-IV6, QC0015-GYS, E-QI-17386-A
Deference in serial model:	All the model are the same circuit and RF module, except the model No..
Operation frequency:	115 – 205 kHz
Operational mode:	Wireless charging
Modulation type:	Load modulation
Antenna type:	Coil Antenna
Power source:	DC 5V form adapter
Adapter information:	N/A

### 1.2 Test mode

To investigate the maximum EMI emission characteristics generates from EUT, the test system was pre-scanning tested base on the consideration of following EUT operation mode or test configuration mode which possible have effect on EMI emission level. Each of these EUT operation mode(s) or test configuration mode(s) mentioned above was evaluated respectively.

Test mode	Description
Mode 1	Charger mode

Note: The test modes were carried out for all operation modes. The final test mode of the EUT was the worst test mode for EMI, and its test data was showed.

### 1.3 EUT test setup

See photographs of the test setup in the report for the actual setup and connections between EUT and support equipment.

### 1.4 Ancillary equipment

Equipment	Model	S/N	Manufacturer
Adapter	QC5800-EU	/	Shenzhen Kosun Industrial Co.,Ltd
Mobile phone	S8	/	SAMSUNG

### 1.5 Measurement Uncertainty

Measurement Uncertainty for a Level of Confidence of 95 %,  $U=2xUc(y)$

Conducted emission(150kHz~30MHz)	$\pm 2.5$ dB
Radiated emission(30MHz~1GHz)	$\pm 4.2$ dB
Radiated emission (above 1GHz)	$\pm 4.3$ dB
Temperature	$\pm 1$ degree
Humidity	$\pm 5$ %

## 2 SUMMARY OF TEST RESULT

Item	Description of Test	Result
FCC Part 18		
1	Conducted emission	Pass
2	Radiated emission	Pass
N/A: Not applicable		

### 3 TEST FACILITIES AND ACCREDITATIONS

#### 3.1 Test laboratory

Test Laboratory	Shenzhen Microtest Co., Ltd
Location	No.102A & 302A, East Block, Hengfang Industrial Park, Xingye Road, Xixiang, Bao'an District, Shenzhen, Guangdong, China
FCC Registration No.:	448573

#### 3.2 Environmental conditions

Temperature:	20°C~30°C
Humidity	30%~70%
Atmospheric pressure	98kPa~101kPa

#### 3.3 Measurement uncertainty

Measurement Uncertainty for a Level of Confidence of 95 %,  $U=2xUc(y)$

RF frequency	$1 \times 10^{-7}$
RF power, conducted	$\pm 1$ dB
Conducted emission(150kHz~30MHz)	$\pm 2.5$ dB
Radiated emission(30MHz~1GHz)	$\pm 4.2$ dB
Radiated emission (above 1GHz)	$\pm 4.3$ dB
Temperature	$\pm 1$ degree
Humidity	$\pm 5$ %

#### 3.4 Test software

Software Name	Manufacturer	Model	Version
RF Test System	Farad	LZ-RF	Lz_Rf 3A3

#### 4 LIST OF TEST EQUIPMENT

Equipment No.	Equipment Name	Manufacturer	Model	Serial No.	Calibration date	Due date
MTI-E001	Spectrum Analyzer	Agilent	E4407B	MY41441082	2017/10/18	2018/10/17
MTI-E002	CMU 200 universal radio communication tester	Rohde&schwarz	CMU 200	114587	2017/10/18	2018/10/17
MTI-E004	EMI Test Receiver	Rohde&schwarz	ESPI	1000314	2017/10/18	2018/10/17
MTI-E006	Broadband antenna	schwarzbeck	VULB9163	872	2017/10/18	2018/10/17
MTI-E007	Horn antenna	schwarzbeck	BBHA9120D	1201	2017/10/18	2018/10/17
MTI-E014	amplifier	America	8447D	3113A06150	2017/10/18	2018/10/17
MTI-E015	Conduction Immunity Signal Generator	Schloder	CDG6000	126A1343/2015	2017/10/18	2018/10/17
MTI-E016	Coupled decoupling network	Schloder	CDA M2/M3	A2210332/2015	2017/10/18	2018/10/17
MTI-E032	Comprehensive test instrument	Rohde&schwarz	CMW500	124192	2018/04/13	2019/04/12
MTI-E034	amplifier	Agilent	8449B	3008A02400	2017/10/22	2018/10/21
MTI-E037	Artificial power network	Schwarzbeck	NSLK8127	#841	2017/09/26	2018/09/25
MTI-E040	Spectrum analyzer	Agilent	N9020A	MY49100060	2018/03/05	2019/03/04
MTI-E041	Signal generator	Agilent	N5182A	MY49060455	2018/02/23	2019/02/22
MTI-E042	Analog signal generator	Agilent	E4421B	GB40051240	2018/02/23	2019/02/22
MTI-E043	Power probe	Dare Instruments	RPR3006W	16I00054SN016	2018/02/28	2019/02/28
MTI-E047	10dB attenuator	Mini-Circuits	UNAT-10+	15542	2018/05/23	2019/05/23
MTI-E049	spectrum analyzer	Rohde&schwarz	FSP-38	100019	2017/10/18	2018/10/17
MTI-E050	PSG Signal generator	Agilent	E8257D	MY46520873	2018/04/24	2019/04/23
MTI-E051	Active Loop Antenna 9kHz - 30MHz	Schwarzbeck	FMZB 1519 B	00044	2018/2/26	2019/02/25
MTI-E052	18-40GHz amplifier	Chengdu step Micro Technology	ZLNA-18-40G-21	1608001	2017/10/18	2018/10/17
MTI-E053	15-40G Antenna	Schwarzbeck	BBHA9170	BBHA9170582	2017/10/18	2018/10/17
MTI-E058	Artificial power network	Schwarzbeck	NSLK8127	#841	2017/12/05	2018/12/04

Note: the calibration interval of the above test instruments is 12 months and the calibrations are traceable to international system unit (SI).



## 5 TEST RESULTS

### 5.1 Conducted emission

#### 5.1.1 Limits

For the following equipment, when designed to be connected to the public utility (AC) power line the radio frequency voltage that is conducted back onto the AC power line on any frequency or frequencies shall not exceed the limits in the following tables. Compliance with the provisions of this paragraph shall be based on the measurement of the radio frequency voltage between each power line and ground at the power terminal using a 50  $\mu$ H/50 ohms line impedance stabilization network (LISN).

Frequency (MHz)	Conducted limit (dB $\mu$ V)	
	Quasi-peak	Average
0.15 -0.5	66 - 56 *	56 - 46 *
0.5 -5	56	46
5 -30	60	50

Note: the limit of " \* " marked band means the limitation decreases linearly with the logarithm of the frequency in the range.

#### 5.1.2 Test Procedures

The EUT was placed 0.8 meters from the horizontal ground plane with EUT being connected to the power mains through a line impedance stabilization network (LISN). All other support equipment powered from additional LISN(s). The LISN provide 50 Ohm/ 50uH of coupling impedance for the measuring instrument.

Interconnecting cables that hang closer than 40 cm to the ground plane shall be folded back and forth in the center forming a bundle 30 to 40 cm long.

I/O cables that are not connected to a peripheral shall be bundled in the center. The end of the cable may be terminated, if required, using the correct terminating impedance. The overall length shall not exceed 1 m.

LISN is at least 80 cm from nearest part of EUT chassis.

For the actual test configuration, please refer to the related Item – photographs of the test setup.

#### 5.1.3 Test Setup

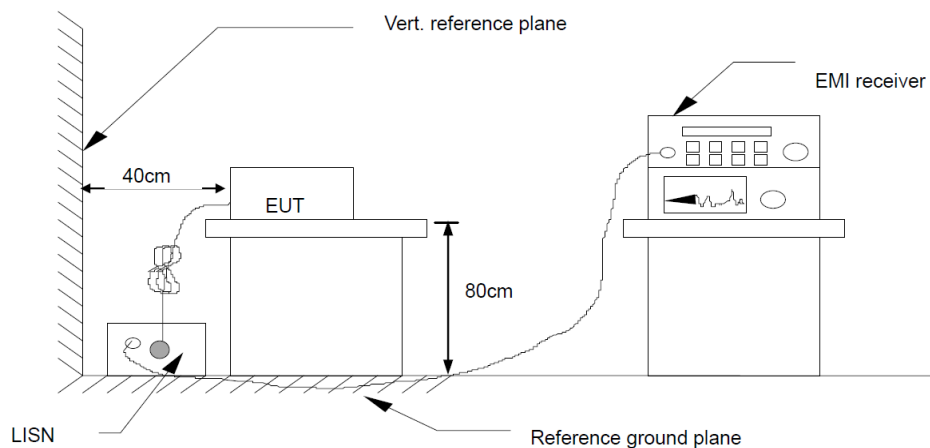

#### 5.1.4 Test Result

Temperature:	27°C	Relative Humidity:	65%
Pressure:	101kPa	Phase:	L
Test voltage:	DC 5V form AC 120V/60Hz	Test mode:	Mode 1

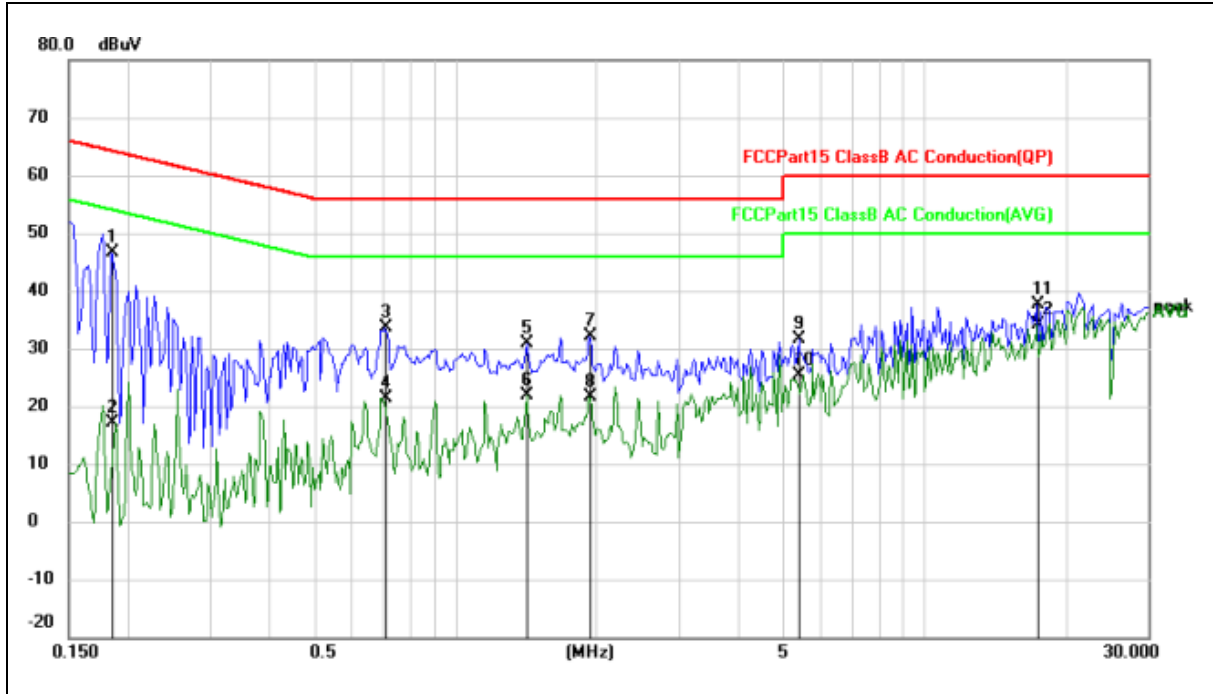

No.	Mk.	Freq. MHz	Reading Level dBuV	Correct Factor dB	Measure- ment dBuV	Limit dB	Over dB	Detector	Comment
1		0.1852	45.14	1.57	46.71	64.25	-17.54	QP	
2		0.1852	15.60	1.57	17.17	54.25	-37.08	AVG	
3		0.7086	31.98	1.57	33.55	56.00	-22.45	QP	
4		0.7086	19.80	1.57	21.37	46.00	-24.63	AVG	
5		1.4194	29.31	1.58	30.89	56.00	-25.11	QP	
6		1.4194	20.22	1.58	21.80	46.00	-24.20	AVG	
7		1.9352	30.49	1.59	32.08	56.00	-23.92	QP	
8		1.9352	20.12	1.59	21.71	46.00	-24.29	AVG	
9		5.4141	31.35	0.34	31.69	60.00	-28.31	QP	
10		5.4141	25.07	0.34	25.41	50.00	-24.59	AVG	
11		17.4180	37.31	0.30	37.61	60.00	-22.39	QP	
12	*	17.4180	33.90	0.30	34.20	50.00	-15.80	AVG	

Temperature:	27°C	Relative Humidity:	65%
Pressure:	101kPa	Phase:	N
Test voltage:	DC 5V form AC 120V/60Hz	Test mode:	Mode 1

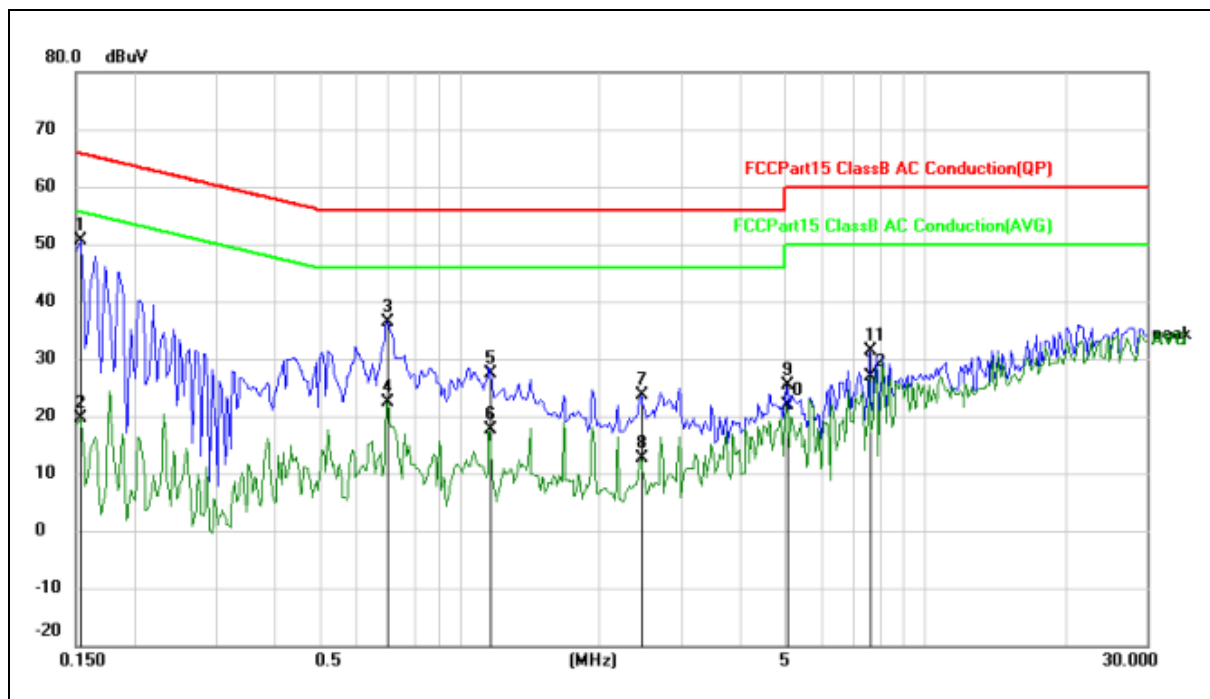

No.	Mk.	Freq. MHz	Reading Level dBuV	Correct Factor dB	Measure- ment dBuV	Limit dBuV	Over dB	Detector	Comment
1	*	0.1539	49.17	1.58	50.75	65.79	-15.04	QP	
2		0.1539	18.03	1.58	19.61	55.79	-36.18	AVG	
3		0.7007	34.81	1.57	36.38	56.00	-19.62	QP	
4		0.7007	20.82	1.57	22.39	46.00	-23.61	AVG	
5		1.1657	25.90	1.58	27.48	56.00	-28.52	QP	
6		1.1657	15.95	1.58	17.53	46.00	-28.47	AVG	
7		2.4547	22.41	1.27	23.68	56.00	-32.32	QP	
8		2.4547	11.33	1.27	12.60	46.00	-33.40	AVG	
9		5.0313	24.96	0.33	25.29	60.00	-34.71	QP	
10		5.0313	21.67	0.33	22.00	50.00	-28.00	AVG	
11		7.6094	30.91	0.38	31.29	60.00	-28.71	QP	
12		7.6094	26.48	0.38	26.86	50.00	-23.14	AVG	

Temperature:	27°C	Relative Humidity:	65%
Pressure:	101kPa	Phase:	L
Test voltage:	DC 5V form AC 240V/60Hz	Test mode:	Mode 1

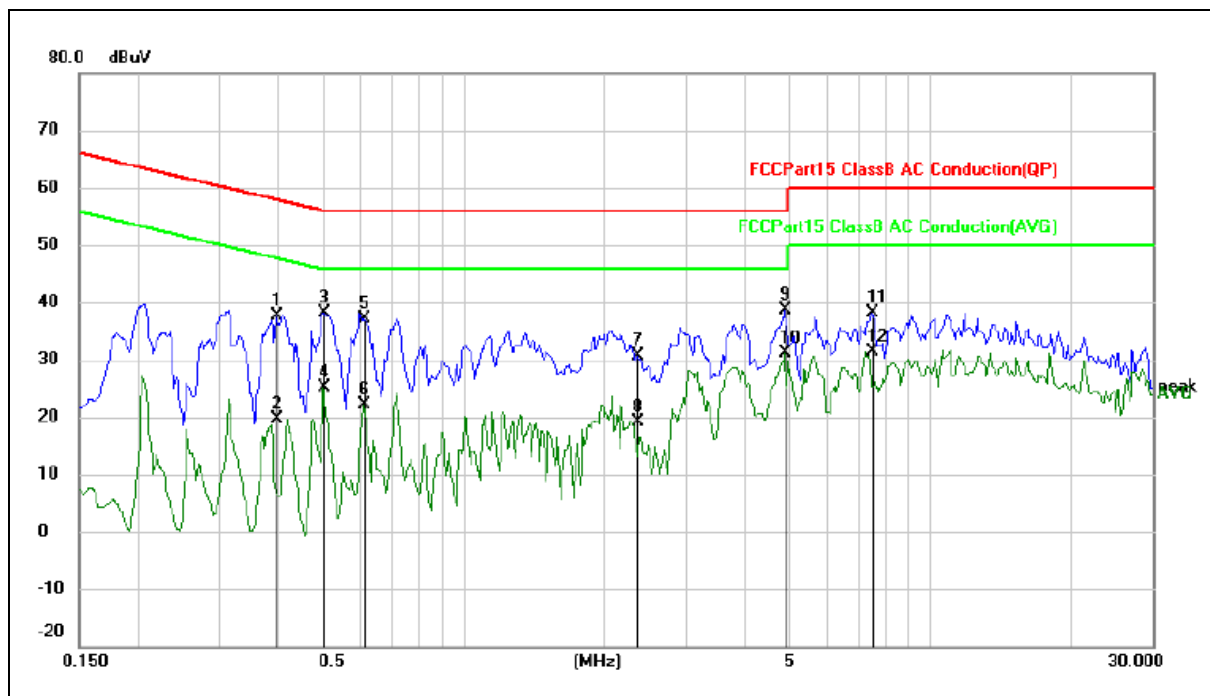

No.	Mk.	Freq. MHz	Reading Level dBuV	Correct Factor dB	Measure- ment dBuV	Limit dBuV	Over dB	Detector	Comment
1		0.3961	35.96	1.57	37.53	57.93	-20.40	QP	
2		0.3961	17.98	1.57	19.55	47.93	-28.38	AVG	
3		0.5016	36.48	1.57	38.05	56.00	-17.95	QP	
4		0.5016	23.55	1.57	25.12	46.00	-20.88	AVG	
5		0.6109	35.55	1.57	37.12	56.00	-18.88	QP	
6		0.6109	20.51	1.57	22.08	46.00	-23.92	AVG	
7		2.3609	29.27	1.34	30.61	56.00	-25.39	QP	
8		2.3609	17.74	1.34	19.08	46.00	-26.92	AVG	
9		4.8867	38.27	0.39	38.66	56.00	-17.34	peak	
10	*	4.8867	30.71	0.39	31.10	46.00	-14.90	AVG	
11		7.5195	37.74	0.38	38.12	60.00	-21.88	QP	
12		7.5195	30.98	0.38	31.36	50.00	-18.64	AVG	

Temperature:	27°C	Relative Humidity:	65%
Pressure:	101kPa	Phase:	N
Test voltage:	DC 5V form AC 240V/60Hz	Test mode:	Mode 1

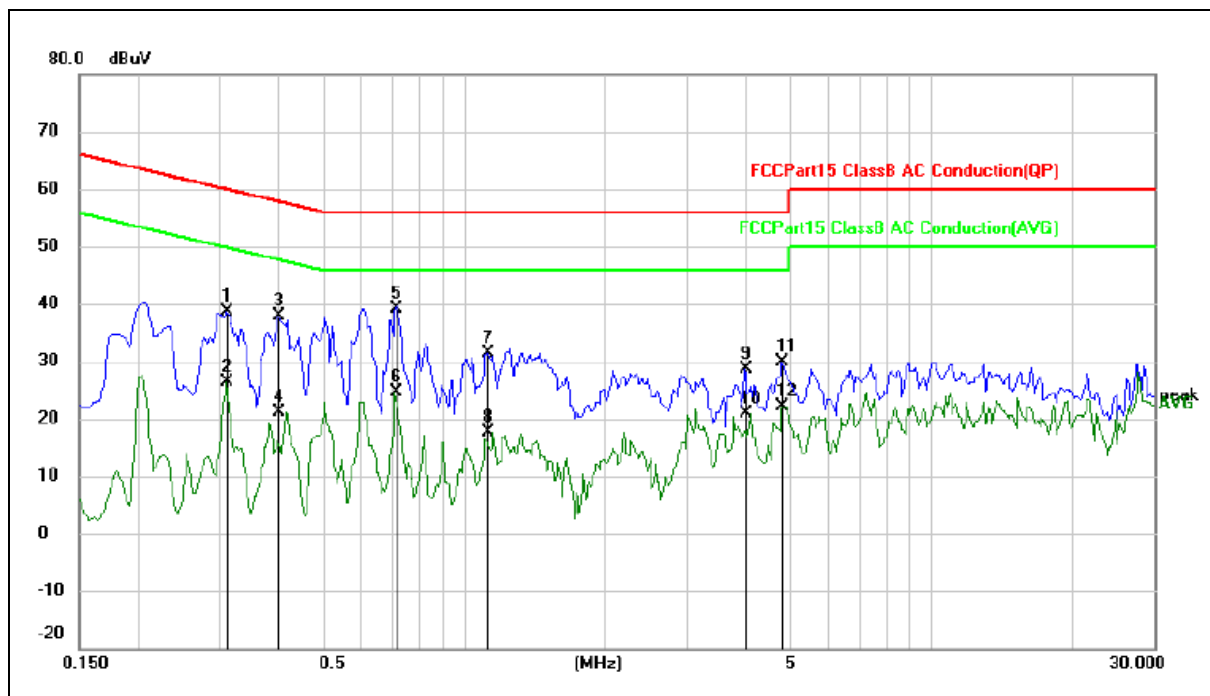

No.	Mk.	Freq. MHz	Reading Level dBuV	Correct Factor dB	Measure- ment dBuV	Limit dBuV	Over dB	Detector	Comment
1		0.3102	37.03	1.57	38.60	59.97	-21.37	QP	
2		0.3102	24.79	1.57	26.36	49.97	-23.61	AVG	
3		0.4000	36.26	1.57	37.83	57.85	-20.02	QP	
4		0.4000	19.54	1.57	21.11	47.85	-26.74	AVG	
5	*	0.7122	37.64	1.57	39.21	56.00	-16.79	QP	
6		0.7122	23.09	1.57	24.66	46.00	-21.34	AVG	
7		1.1266	29.73	1.58	31.31	56.00	-24.69	QP	
8		1.1266	16.03	1.58	17.61	46.00	-28.39	AVG	
9		4.0038	27.62	0.89	28.51	56.00	-27.49	QP	
10		4.0038	19.97	0.89	20.86	46.00	-25.14	AVG	
11		4.7852	29.34	0.45	29.79	56.00	-26.21	QP	
12		4.7852	21.57	0.45	22.02	46.00	-23.98	AVG	

5.2 Radiated emission

5.2.1 Limits

Frequency range (9kHz – 30MHz)

Except as provided elsewhere in this Subpart 18.305 (b), the field strength levels of emissions which lie outside the bands specified in §18.301, unless otherwise indicated, shall not exceed the following table:

Frequency (MHz)	Field Strengths Limit (at 3m) dB $\mu$ V/m	Detector
0.009-30	103.5	Peak

Remark:

- (1) Emission level dB $\mu$ V/m for 0.009~30MHz = 20log (15) + 40log (300/3) dB $\mu$ V/m;
- (2) Calculated according FCC 18.305.
- (3) The smaller limit shall apply at the cross point between two frequency bands.
- (4) Distance is the distance in meters between the measuring instrument, antenna and the closest point of any part of the device or system.

Frequency range (30MHz – 1GHz)

Frequency (MHz)	Class B device (at 3m) dB $\mu$ V/m	Detector
30-88	40	QP
88-216	43.5	QP
216-1000	46	QP

5.2.2 Test Procedures

The radiated emission tests were performed in the 3 meters. The EUT was placed on the top of a rotating table 0.8 meters above the ground. The table was rotated 360 degrees to determine the position of the highest radiation. The height of the test antenna shall vary between 1m to 4m. Both horizontal and vertical polarizations of the antenna are set to make the measurement. If the peak mode measured value compliance with and lower than quasi peak mode limit, the EUT shall be deemed to meet QP limits and then no additional QP mode measurement performed. If the peak mode measured value compliance with and lower than average mode limit, the EUT shall be deemed to meet average limits and then no additional average mode measurement performed. For the actual test configuration, please refer to the related item – EUT test photos.

### 5.2.3 Test Setup

#### Radiated emission test-up frequency below 30MHz

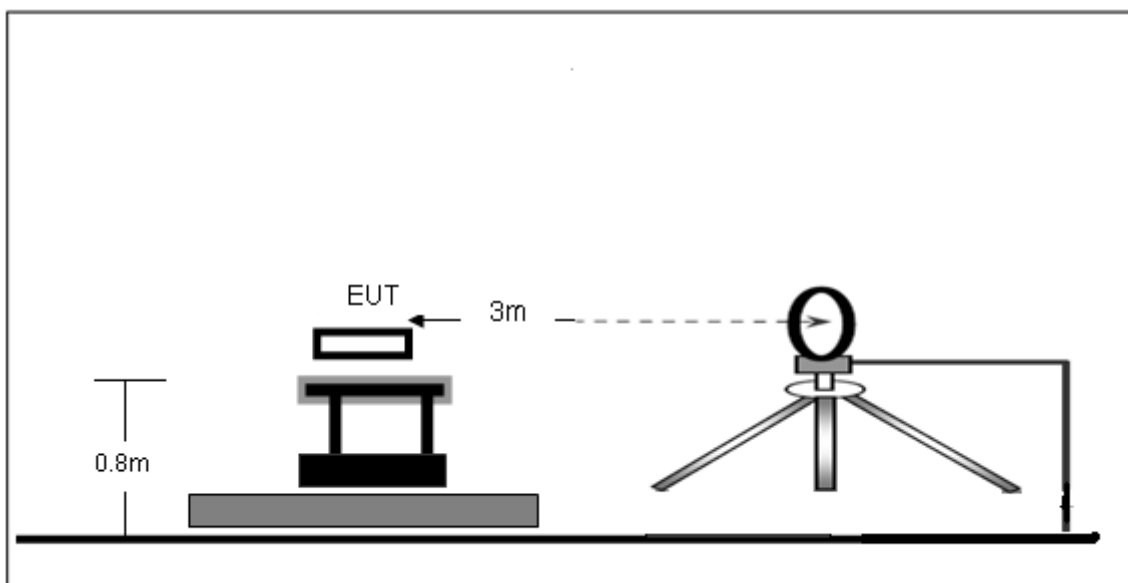

#### Radiated emission test-up frequency 30MHz~1GHz

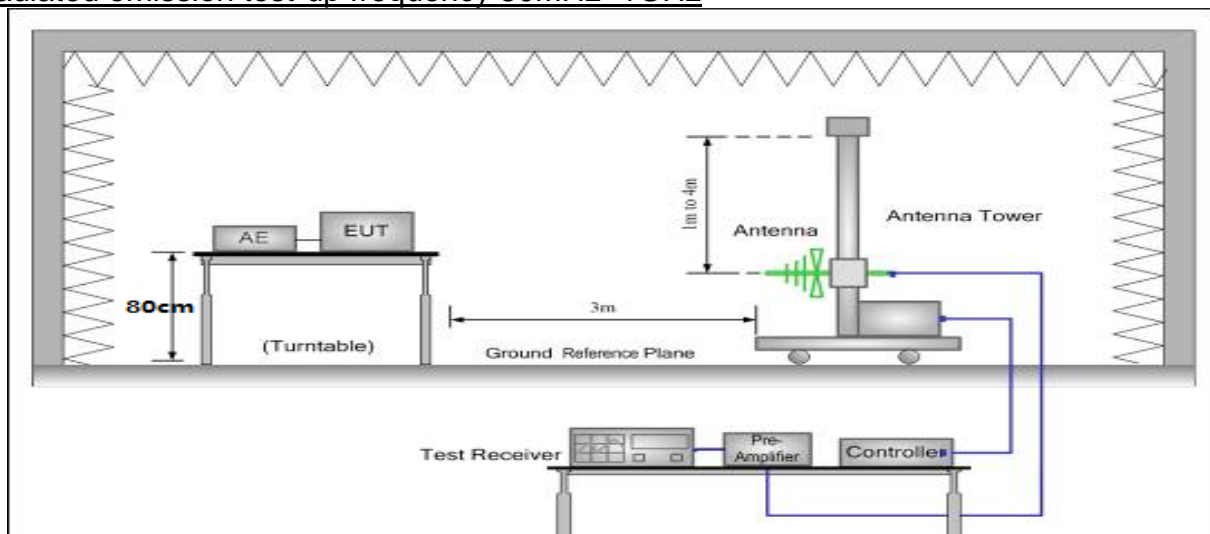

5.2.4 Test Result

Frequency range (9kHz – 30MHz)

Temperature:	23℃	Relative Humidity:	59%
Pressure:	101kPa	Polarization:	Horizontal
Test voltage:	DC 5V form AC 120V/60Hz	Test mode:	Mode 1

Frequency	Reading Level	Cable Loss	Antenna Factor	Emission Level	Limits	Margin	Detector	Comment
(MHz)	(dBμV)	(dB)	dB/m	(dBμV/m)	(dBμV/m)	(dB)	Type	
0.015	57.33	0.30	20.57	78.20	103.5	-25.30	Pk	Horizontal
0.094	55.33	0.30	20.61	76.24	103.5	-27.26	Pk	Horizontal
0.115	69.96	0.30	20.77	91.03	103.5	-12.47	Pk	Horizontal
1.534	42.11	0.30	20.81	63.22	103.5	-40.28	Pk	Horizontal
9.245	35.56	0.30	20.89	56.75	103.5	-46.75	Pk	Horizontal
14.263	36.56	0.30	20.92	57.78	103.5	-45.72	Pk	Horizontal



Frequency range (30MHz – 1GHz)

Temperature:	23°C	Relative Humidity:	59%
Pressure:	101kPa	Polarization:	Horizontal
Test voltage:	DC 5V form AC 120V/60Hz	Test mode:	Mode 1

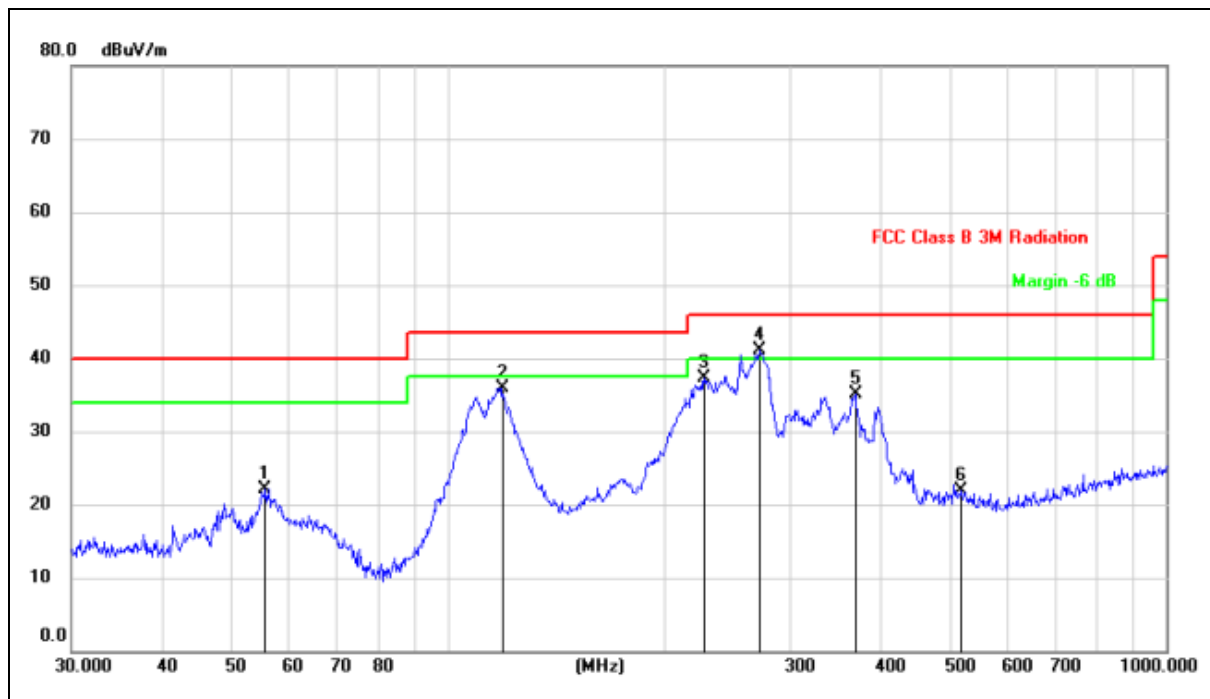

No.	Mk.	Freq.	Reading Level	Correct Factor	Measurement	Limit	Over	Antenna Height	Table Degree	
		MHz	dBuV	dBuV/m	dBuV/m	dBuV/m	dB	cm	degree	Comment
1		55.8047	32.59	-10.54	22.05	40.00	-17.95	QP		
2		119.0180	48.89	-12.90	35.99	43.50	-7.51	QP		
3		227.6906	48.00	-10.78	37.22	46.00	-8.78	QP		
4	*	271.3246	50.47	-9.42	41.05	46.00	-4.95	QP		
5		369.4047	42.24	-7.18	35.06	46.00	-10.94	QP		
6		519.0649	26.99	-5.13	21.86	46.00	-24.14	QP		

Temperature:	23°C	Relative Humidity:	59%
Pressure:	101kPa	Polarization:	Vertical
Test voltage:	DC 5V form AC 120V/60Hz	Test mode:	Mode 1

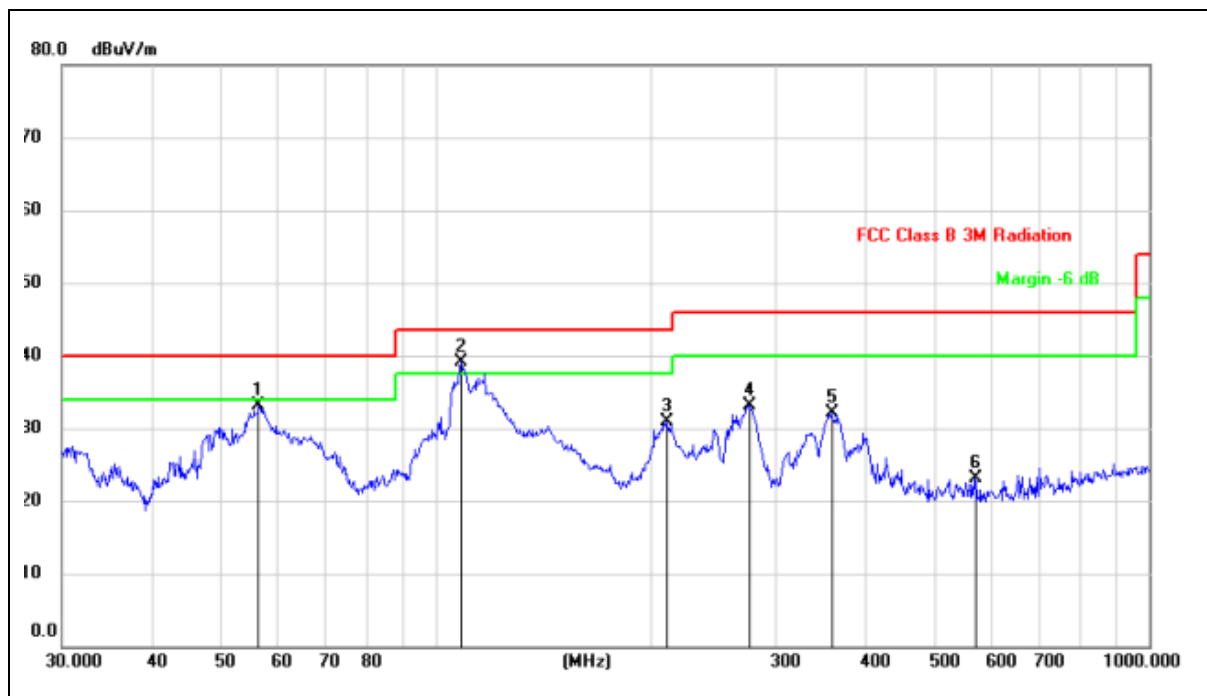

No.	Mk.	Freq. MHz	Reading Level dBuV	Correct Factor dBuV/m	Measure- ment dBuV/m	Limit dBuV/m	Over dB	Antenna Height cm	Table Degree degree	Comment
1		56.5929	43.83	-10.65	33.18	40.00	-6.82	QP		
2	*	108.6470	50.64	-11.45	39.19	43.50	-4.31	QP		
3		210.7860	41.34	-10.36	30.98	43.50	-12.52	QP		
4		274.1939	41.52	-8.34	33.18	46.00	-12.82	QP		
5		359.1860	39.55	-7.40	32.15	46.00	-13.85	QP		
6		568.6127	27.99	-4.88	23.11	46.00	-22.89	QP		

## Photographs of the Test Setup

Radiated emission

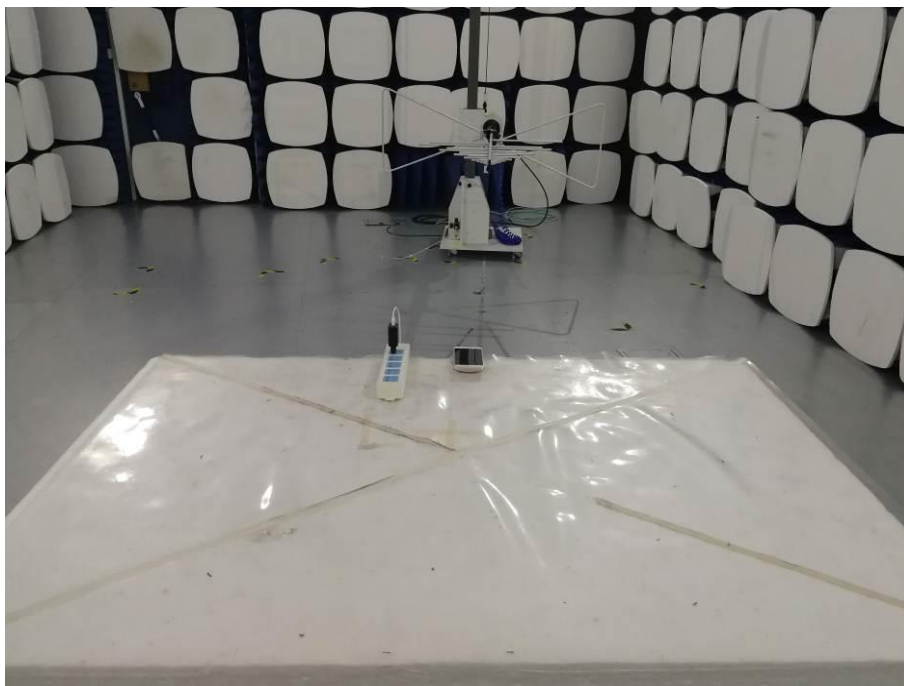
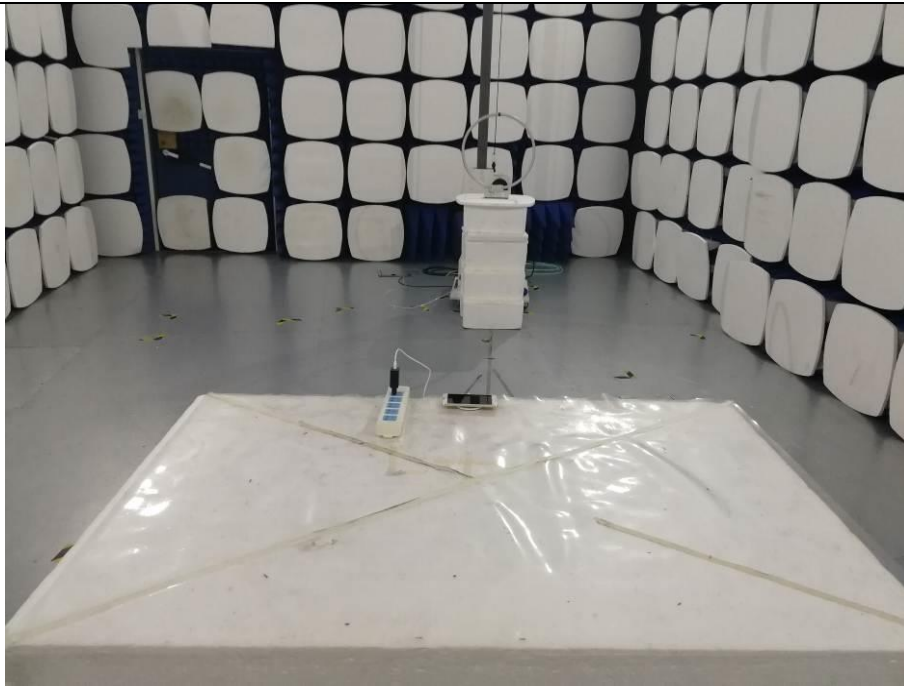

Conducted emission



## **Photographs of the EUT**

See the APPENDIX 1: EUT PHOTO in the report NO.: MTi180920E121-1

**----END OF REPORT----**