

# FCC Radio Test Report

## FCC ID: 2AG7C-MINI15S

This report concerns: Original Grant

**Project No.** : 2009H027  
**Equipment** : IP CAMERA  
**Brand Name** : N/A  
**Test Model** : Mini 15S  
**Series Model** : Mini 15T  
**Applicant** : Hangzhou Meari Technology Co., Ltd.  
**Address** : Room 604-605, Building 1, No.768 Jianghong Road, Changhe street, Binjiang District, Hangzhou, Zhejiang, China  
**Manufacturer** : Hangzhou Meari Technology Co., Ltd.  
**Address** : Room 604-605, Building 1, No.768 Jianghong Road, Changhe street, Binjiang District, Hangzhou, Zhejiang, China  
**Factory** : Hangzhou Meari Technology Co., Ltd.  
**Address** : No. 91 Chutian Road, Xixing Street, Binjiang District, Hangzhou, Zhejiang, China  
**Date of Receipt** : Sep. 15, 2020  
**Date of Test** : Oct. 09, 2020~Oct. 13, 2020  
**Issued Date** : Oct. 22, 2020  
**Report Version** : R00  
**Test Sample** : Engineering Sample No.: SH2020091128, SH2020091126-1, SH2020091129-2, SH2020091129-1  
**Standard(s)** : FCC Part15, Subpart C (15.247)  
ANSI C63.10-2013  
KDB 558074 D01 15.247 Meas Guidance v05r02

The above equipment has been tested and found compliance with the requirement of the relative standards by BTL Inc.

*Allen Wei*

Prepared by : Allen Wei

*Ryan Wang*

Approved by : Ryan Wang



Certificate # 5123.03

Add: No. 29, Jintang Road, Tangzhen Industry Park, Pudong New Area, Shanghai 201210, China

TEL: +86-021-61765666

Web: www.newbtl.com

**Declaration**

**BTL** represents to the client that testing is done in accordance with standard procedures as applicable and that test instruments used has been calibrated with standards traceable to international standard(s) and/or national standard(s).

**BTL's** reports apply only to the specific samples tested under conditions. It is manufacture's responsibility to ensure that additional production units of this model are manufactured with the identical electrical and mechanical components. **BTL** shall have no liability for any declarations, inferences or generalizations drawn by the client or others from **BTL** issued reports.

The report must not be used by the client to claim product certification, approval, or endorsement by NVLAP, NIST, A2LA, or any agency of the U.S. Government.

This report is the confidential property of the client. As a mutual protection to the clients, the public and ourselves, the test report shall not be reproduced, except in full, without our written approval.

**BTL's** laboratory quality assurance procedures are in compliance with the **ISO/IEC 17025** requirements, and accredited by the conformity assessment authorities listed in this test report.

**BTL** is not responsible for the sampling stage, so the results only apply to the sample as received.

The information, data and test plan are provided by manufacturer which may affect the validity of results, so it is manufacturer's responsibility to ensure that the apparatus meets the essential requirements of applied standards and in all the possible configurations as representative of its intended use.

**Limitation**

For the use of the authority's logo is limited unless the Test Standard(s)/Scope(s)/Item(s) mentioned in this test report is (are) included in the conformity assessment authorities acceptance respective.

Please note that the measurement uncertainty is provided for informational purpose only and are not use in determining the Pass/Fail results.

<b>Table of Contents</b>	<b>Page</b>
<b>REPORT ISSUED HISTORY</b>	<b>6</b>
<b>1 . SUMMARY OF TEST RESULTS</b>	<b>7</b>
1.1 TEST FACILITY	7
1.2 MEASUREMENT UNCERTAINTY	8
1.3 TEST ENVIRONMENT CONDITIONS	8
<b>2 . GENERAL INFORMATION</b>	<b>9</b>
2.1 GENERAL DESCRIPTION OF EUT	9
2.2 DESCRIPTION OF TEST MODES	10
2.3 PARAMETERS OF TEST SOFTWARE	12
2.4 DUTY CYCLE	13
2.5 BLOCK DIAGRAM SHOWING THE CONFIGURATION OF SYSTEM TESTED	14
2.6 SUPPORT UNITS	14
<b>3 . AC POWER LINE CONDUCTED EMISSIONS TEST</b>	<b>15</b>
3.1 LIMIT	15
3.2 TEST PROCEDURE	15
3.3 DEVIATION FROM TEST STANDARD	15
3.4 TEST SETUP	16
3.5 EUT OPERATION CONDITIONS	16
3.6 TEST RESULTS	16
<b>4 . RADIATED EMISSIONS TEST</b>	<b>17</b>
4.1 LIMIT	17
4.2 TEST PROCEDURE	18
4.3 DEVIATION FROM TEST STANDARD	18
4.4 TEST SETUP	19
4.5 EUT OPERATION CONDITIONS	20
4.6 TEST RESULTS - 9 KHZ TO 30 MHZ	20
4.7 TEST RESULTS - 30 MHZ TO 1000 MHZ	20
4.8 TEST RESULTS - ABOVE 1000 MHZ	20
<b>5 . BANDWIDTH TEST</b>	<b>21</b>
5.1 LIMIT	21
5.2 TEST PROCEDURE	21
5.3 DEVIATION FROM STANDARD	21
5.4 TEST SETUP	21

<b>Table of Contents</b>	<b>Page</b>
5.5 EUT OPERATION CONDITIONS	21
5.6 TEST RESULTS	21
<b>6 . MAXIMUM OUTPUT POWER TEST</b>	<b>22</b>
6.1 LIMIT	22
6.2 TEST PROCEDURE	22
6.3 DEVIATION FROM STANDARD	22
6.4 TEST SETUP	22
6.5 EUT OPERATION CONDITIONS	22
6.6 TEST RESULTS	22
<b>7 . CONDUCTED SPURIOUS EMISSIONS</b>	<b>23</b>
7.1 LIMIT	23
7.2 TEST PROCEDURE	23
7.3 DEVIATION FROM STANDARD	23
7.4 TEST SETUP	23
7.5 EUT OPERATION CONDITIONS	23
7.6 TEST RESULTS	23
<b>8 . POWER SPECTRAL DENSITY TEST</b>	<b>24</b>
8.1 LIMIT	24
8.2 TEST PROCEDURE	24
8.3 DEVIATION FROM STANDARD	24
8.4 TEST SETUP	24
8.5 EUT OPERATION CONDITIONS	24
8.6 TEST RESULTS	24
<b>9 . MEASUREMENT INSTRUMENTS LIST</b>	<b>25</b>
<b>10 . EUT TEST PHOTO</b>	<b>27</b>
<b>APPENDIX A - AC POWER LINE CONDUCTED EMISSIONS</b>	<b>30</b>
<b>APPENDIX B - RADIATED EMISSION - 9 KHZ TO 30 MHZ</b>	<b>33</b>
<b>APPENDIX C - RADIATED EMISSION - 30 MHZ TO 1000 MHZ</b>	<b>34</b>
<b>APPENDIX D - RADIATED EMISSION- ABOVE 1000 MHZ</b>	<b>37</b>
<b>APPENDIX E - BANDWIDTH</b>	<b>86</b>
<b>APPENDIX F - MAXIMUM OUTPUT POWER</b>	<b>91</b>
<b>APPENDIX G - CONDUCTED SPURIOUS EMISSIONS</b>	<b>93</b>

**Table of Contents****Page****APPENDIX H - POWER SPECTRAL DENSITY****98**

**REPORT ISSUED HISTORY**

Report Version	Description	Issued Date
R00	Original Issue.	Oct. 22, 2020

## 1. SUMMARY OF TEST RESULTS

Test procedures according to the technical standard(s):

FCC Part15, Subpart C (15.247)				
Standard(s) Section	Test Item	Test Result	Judgment	Remark
15.207	AC Power Line Conducted Emissions	APPENDIX A	PASS	-----
15.247(d) 15.205(a) 15.209(a)	Radiated Emissions	APPENDIX B APPENDIX C APPENDIX D	PASS	-----
15.247(a)(2)	Bandwidth	APPENDIX E	PASS	-----
15.247(b)(3)	Maximum Output Power	APPENDIX F	PASS	-----
15.247(d)	Conducted Spurious Emissions	APPENDIX G	PASS	-----
15.247(e)	Power Spectral Density	APPENDIX H	PASS	-----
15.203	Antenna Requirement	-----	PASS	Note(2)

Note:

- (1) "N/A" denotes test is not applicable in this test report.
- (2) The device what use a permanently attached antenna were considered sufficient to comply with the provisions of 15.203.

### 1.1 TEST FACILITY

The test facilities used to collect the test data in this report is at the location of No. 29, Jintang Road, Tangzhen Industry Park, Pudong New Area, Shanghai 201210,China  
 BTL's Test Firm Registration Number for FCC: 476765  
 BTL's Designation Number for FCC: CN1241

## 1.2 MEASUREMENT UNCERTAINTY

ISO/IEC 17025 requires that an estimate of the measurement uncertainties associated with the emissions test results be included in the report. The measurement uncertainties given below are based on a 95% confidence level (based on a coverage factor (k=2))

The BTL measurement uncertainty as below table:

### A. Radiated emissions test:

Test Site	Method	Measurement Frequency Range	Ant. H / V	U, (dB)
SH-CB01	CISPR	9 KHz~30 MHz	V	3.79
		9 KHz~30 MHz	H	3.57
		30 MHz~200 MHz	V	4.04
		30 MHz~200 MHz	H	3.76
		200 MHz~1,000 MHz	V	4.24
		200 MHz~1,000 MHz	H	3.84
		1 GHz~18 GHz	V	4.46
		1 GHz~18 GHz	H	4.40
		18 GHz~40 GHz	V	3.95
		18 GHz~40 GHz	H	3.95

Note: Unless specifically mentioned, the uncertainty of measurement has not been taken into account to declare the compliance or non-compliance to the specification.

## 1.3 TEST ENVIRONMENT CONDITIONS

Test Item	Temperature	Humidity	Test Voltage	Tested By
AC Power Line Conducted Emissions	22°C	48%	AC 120V/60Hz	Forest
Radiated Emissions-9K-30MHz	24°C	58%	AC 120V/60Hz	Forest
Radiated Emissions-30 MHz to 1GHz	24°C	58%	AC 120V/60Hz	Forest
Radiated Emissions-Above 1000 MHz	24°C	58%	AC 120V/60Hz	Forest
Bandwidth	22°C	48%	AC 120V/60Hz	Forest
Maximum output power & e.i.r.p.	22°C	48%	AC 120V/60Hz	Forest
Conducted Spurious Emissions	22°C	48%	AC 120V/60Hz	Forest
Power Spectral Density	22°C	48%	AC 120V/60Hz	Forest



## 2. GENERAL INFORMATION

### 2.1 GENERAL DESCRIPTION OF EUT

Equipment	IP CAMERA
Brand Name	N/A
Test Model	Mini 15S
Series Model	Mini 15T
Model Difference(s)	Only differs in model name.
Software Version	Smart life
Hardware Version	PCB-MINI15S-H1MB_F37_REV1_0
Power Source	DC voltage supplied from AC/DC adapter. 1#Brand/Model: TPA-46B050100UU 2#Brand/Model: GTA92-0501000US
Power Rating	1# I/P: 100V-240V ~ 50Hz/60Hz 0.2A O/P: 5.0V === 1000mA. 2# I/P: 100V-240V ~ 50Hz/60Hz 0.3A O/P: USB-A 5.0V === 1.0A. 5.0W
Operation Frequency	2412 MHz ~ 2462 MHz
Modulation Type	IEEE 802.11b: DSSS IEEE 802.11g: OFDM IEEE 802.11n: OFDM
Bit Rate of Transmitter	IEEE 802.11b: 11/5.5/2/1 Mbps IEEE 802.11g: 54/48/36/24/18/12/9/6 Mbps IEEE 802.11n: up to 150 Mbps
Maximum Output Power Non-Beamforming	IEEE 802.11b: 17.82 dBm (0.0605 W) IEEE 802.11g: 17.97 dBm (0.0627 W) IEEE 802.11n (HT20): 17.82 dBm (0.0605 W) IEEE 802.11n (HT40): 17.80 dBm (0.0603 W)

Note:

- For a more detailed features description, please refer to the manufacturer's specifications or the user's manual.
- Channel List:

CH01 - CH11 for IEEE 802.11b, IEEE 802.11g, IEEE 802.11n (HT20) CH03 - CH09 for IEEE 802.11n (HT40)							
Channel	Frequency (MHz)	Channel	Frequency (MHz)	Channel	Frequency (MHz)	Channel	Frequency (MHz)
01	2412	04	2427	07	2442	10	2457
02	2417	05	2432	08	2447	11	2462
03	2422	06	2437	09	2452		

### 3. Antenna Specification:

Ant.	Brand	Model Name	Antenna Type	Connector	Gain (dBi)	Note
1	N/A	N/A	FPC	N/A	3	N/A

## 2.2 DESCRIPTION OF TEST MODES

The test system was pre-tested based on the consideration of all possible combinations of EUT operation mode.

Pretest Mode	Description
Mode 1	TX B Mode Channel 01/06/11
Mode 2	TX G Mode Channel 01/06/11
Mode 3	TX N-20 MHz Mode Channel 01/06/11
Mode 4	TX N-40 MHz Mode Channel 03/06/09
Mode 5	TX G Mode Channel 06

Following mode(s) as (were) found to be the worst case(s) and selected for the final test.

<b>AC power line conducted emissions test</b>	
Final Test Mode:	Description
Mode 5	TX G Mode Channel 06

<b>Radiated emissions test - Below 1GHz</b>	
Final Test Mode:	Description
Mode 5	TX G Mode Channel 06

<b>Radiated emissions test- Above 1GHz</b>	
Final Test Mode:	Description
Mode 1	TX B Mode Channel 01/06/11
Mode 2	TX G Mode Channel 01/06/11
Mode 3	TX N-20 MHz Mode Channel 01/06/11
Mode 4	TX N-40 MHz Mode Channel 03/06/09

<b>Conducted test</b>	
Final Test Mode:	Description
Mode 1	TX B Mode Channel 01/06/11
Mode 2	TX G Mode Channel 01/06/11
Mode 3	TX N-20 MHz Mode Channel 01/06/11
Mode 4	TX N-40 MHz Mode Channel 03/06/09

**NOTE:**

- (1) The measurements are performed at the high, middle, low available channels.
- (2) 802.11b mode: CCK (1 Mbps)  
802.11g mode: OFDM (6 Mbps)  
802.11n HT20 mode : BPSK (6.5 Mbps)  
802.11n HT40 mode : BPSK (13.5 Mbps)  
For radiated emission tests, the highest output powers were set for final test.
- (3) For radiated emission below 1 GHz test, the IEEE 802.11g Channel 06 is found to be the worst case and recorded.

**2.3 PARAMETERS OF TEST SOFTWARE**

Test Software	MPTool 1.0.0.9		
Frequency (MHz)	2412	2437	2462
IEEE 802.11b	45	46	47
IEEE 802.11g	59	59	60
IEEE 802.11n (HT20)	58	59	61
Frequency (MHz)	2422	2437	2452
IEEE 802.11n (HT40)	57	54	59

## 2.4 DUTY CYCLE

If duty cycle is  $\geq 98\%$ , duty factor is not required.  
 If duty cycle is  $< 98\%$ , duty factor shall be considered.  
 The output power = measured power + duty factor.

**IEEE 802.11b**

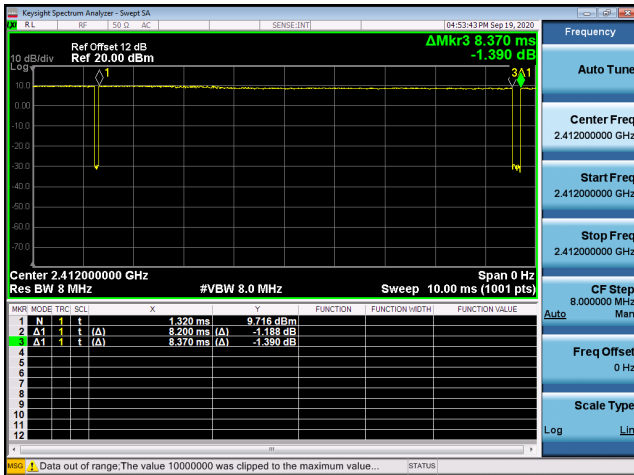

Duty cycle =  $8.200 \text{ ms} / 8.370 \text{ ms} = 97.97\%$   
 Duty Factor =  $10 \log(1/\text{Duty cycle}) = 0.09$

**IEEE 802.11g**

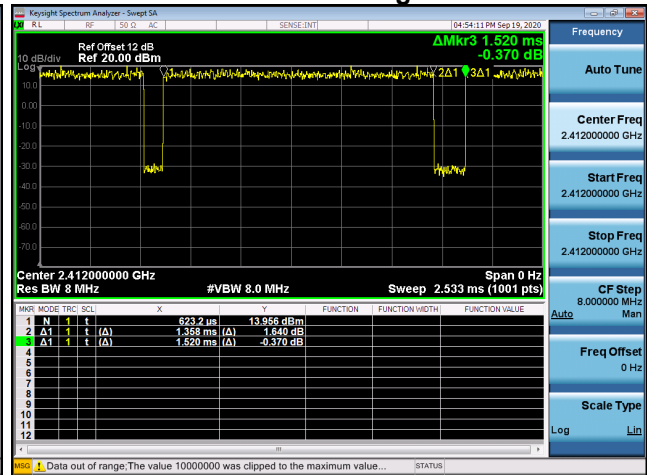

Duty cycle =  $1.358 \text{ ms} / 1.520 \text{ ms} = 89.34\%$   
 Duty Factor =  $10 \log(1/\text{Duty cycle}) = 0.49$

**IEEE 802.11n (HT20)**

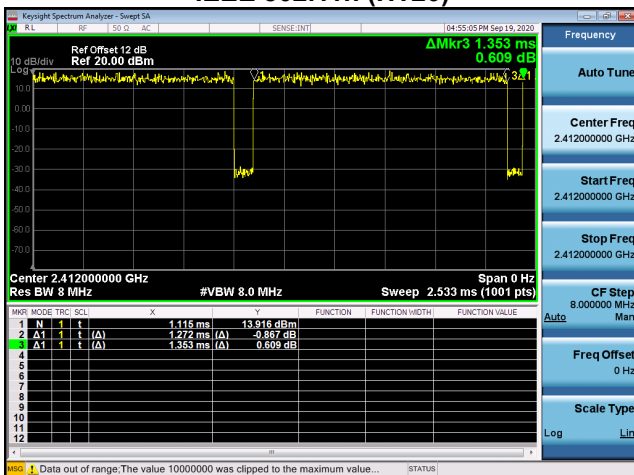

Duty cycle =  $1.272 \text{ ms} / 1.353 \text{ ms} = 94.01\%$   
 Duty Factor =  $10 \log(1/\text{Duty cycle}) = 0.27$

**IEEE 802.11n (HT40)**

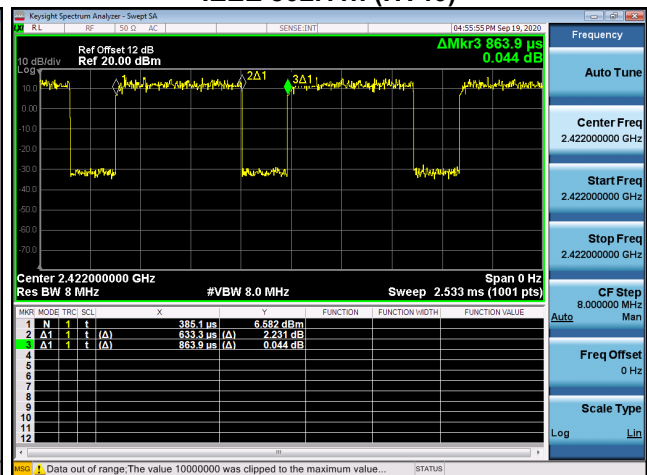

Duty cycle =  $0.633 \text{ ms} / 0.863 \text{ ms} = 73.35\%$   
 Duty Factor =  $10 \log(1/\text{Duty cycle}) = 1.35$

**NOTE:**

For IEEE 802.11g and IEEE 802.11n (HT20):

For radiated emissions frequency above 1 GHz, the resolution bandwidth of test receiver/spectrum analyzer is 1 MHz and the video bandwidth is 1 kHz (Duty cycle  $< 98\%$ ).

For IEEE 802.11n (HT40):

For radiated emissions frequency above 1 GHz, the resolution bandwidth of test receiver/spectrum analyzer is 1 MHz and the video bandwidth is 2 kHz (Duty cycle  $< 98\%$ ).

## 2.5 BLOCK DIAGRAM SHOWING THE CONFIGURATION OF SYSTEM TESTED

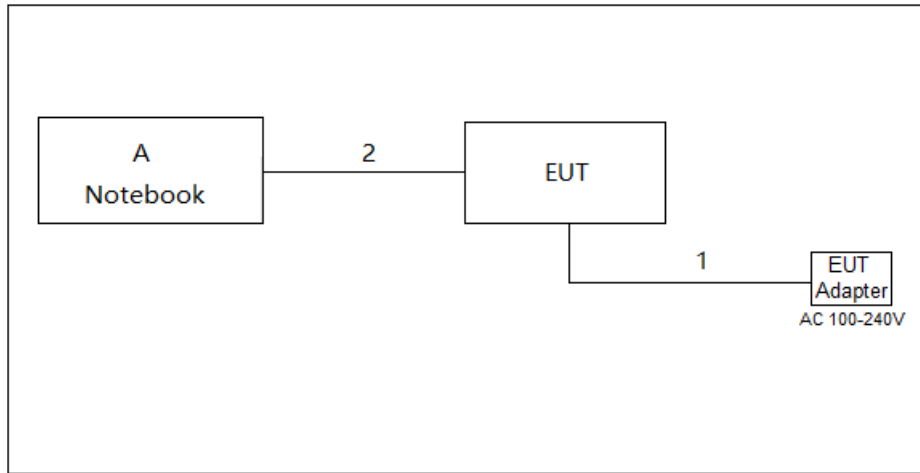

## 2.6 SUPPORT UNITS

Item	Equipment	Brand	Model No.	Series No.
A	Notebook	Dell	N/A	N/A

Item	Cable Type	Shielded Type	Ferrite Core	Length
1	DC Cable	NO	NO	1.5m
2	USB	NO	NO	0.5m

### 3. AC POWER LINE CONDUCTED EMISSIONS TEST

#### 3.1 LIMIT

Frequency of Emission (MHz)	Limit (dB $\mu$ V)	
	Quasi-peak	Average
0.15 - 0.50	66 to 56*	56 to 46*
0.50 - 5.0	56	46
5.0 - 30.0	60	50

**NOTE:**

- (1) The tighter limit applies at the band edges.
- (2) The limit of "\*" marked band means the limitation decreases linearly with the logarithm of the frequency in the range.

The following table is the setting of the receiver

Receiver Parameters	Setting
Attenuation	10 dB
Start Frequency	0.15 MHz
Stop Frequency	30 MHz
IF Bandwidth	9 kHz

#### 3.2 TEST PROCEDURE

- a. The EUT was placed 0.8 meters from the horizontal ground plane with EUT being connected to the power mains through a line impedance stabilization network (LISN). All other support equipment powered from additional LISN(s). The LISN provide 50 Ohm/ 50uH of coupling impedance for the measuring instrument.
- b. Interconnecting cables that hang closer than 40 cm to the ground plane shall be folded back and forth in the center forming a bundle 30 to 40 cm long.
- c. I/O cables that are not connected to a peripheral shall be bundled in the center. The end of the cable may be terminated, if required, using the correct terminating impedance. The overall length shall not exceed 1 m.
- d. LISN at least 80 cm from nearest part of EUT chassis.
- e. For the actual test configuration, please refer to the related Item -EUT Test Photos.

#### 3.3 DEVIATION FROM TEST STANDARD

No deviation

### 3.4 TEST SETUP

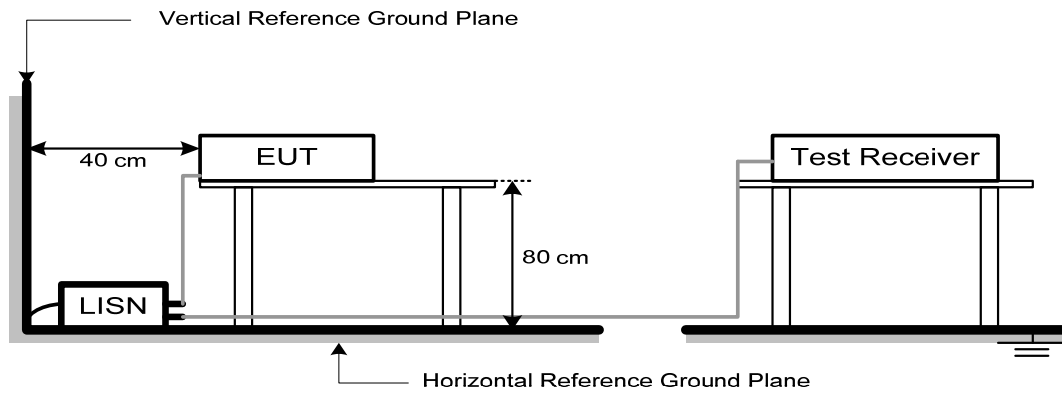

### 3.5 EUT OPERATION CONDITIONS

EUT was programmed to be in continuously transmitting mode.

### 3.6 TEST RESULTS

Please refer to the APPENDIX A.



## 4. RADIATED EMISSIONS TEST

### 4.1 LIMIT

In case the emission fall within the restricted band specified on 15.205(a), then the 15.209(a) limit in the table below has to be followed.

#### LIMITS OF RADIATED EMISSION MEASUREMENT (9 kHz-1000 MHz)

Frequency (MHz)	Field Strength (microvolts/meter)	Measurement Distance (meters)
0.009-0.490	2400/F(kHz)	300
0.490-1.705	24000/F(kHz)	30
1.705-30.0	30	30
30-88	100	3
88-216	150	3
216-960	200	3
Above 960	500	3

#### LIMITS OF RADIATED EMISSION MEASUREMENT (Above 1000 MHz)

Frequency (MHz)	(dBuV/m at 3 m)	
	Peak	Average
Above 1000	74	54

#### NOTE:

- (1) The limit for radiated test was performed according to FCC PART 15C.
- (2) The tighter limit applies at the band edges.
- (3) Emission level (dBuV/m)=20log Emission level (uV/m).
- (4) The test result calculated as following:  
 Measurement Value = Reading Level + Correct Factor  
 Correct Factor = Antenna Factor + Cable Loss - Amplifier Gain(if use)  
 Margin Level = Measurement Value - Limit Value

Spectrum Parameter	Setting
Attenuation	Auto
Start Frequency	1000 MHz
Stop Frequency	10th carrier harmonic
RBW / VBW (Emission in restricted band)	1 MHz / 3 MHz for Peak, 1 MHz / 1/T for Average

Receiver Parameter	Setting
Attenuation	Auto
Start ~ Stop Frequency	9 kHz~90 kHz for PK/AVG detector
Start ~ Stop Frequency	90 kHz~110 kHz for QP detector
Start ~ Stop Frequency	110 kHz~490 kHz for PK/AVG detector
Start ~ Stop Frequency	490 kHz~30 MHz for QP detector
Start ~ Stop Frequency	30 MHz~1000 MHz for QP detector

## 4.2 TEST PROCEDURE

- a. The measuring distance of 3 m shall be used for measurements. The EUT was placed on the top of a rotating table 0.8 meter above the ground at a 3 meter semi-anechoic chamber. The table was rotated 360 degrees to determine the position of the highest radiation.(below 1 GHz)
- b. The measuring distance of 3 m shall be used for measurements. The EUT was placed on the top of a rotating table 1.5 meter above the ground at a 3 meter semi-anechoic chamber. The table was rotated 360 degrees to determine the position of the highest radiation.(above 1 GHz)
- c. The height of the equipment or of the substitution antenna shall be 0.8m or 1.5m; the height of the test antenna shall vary between 1 m to 4 m. Both horizontal and vertical polarizations of the antenna are set to make the measurement.
- d. For each suspected emission, the EUT was arranged to its worst case and then the antenna was tuned to heights find the maximum reading (used Bore sight function).
- e. The receiver system was set to peak and average detect function and specified bandwidth with maximum hold mode when the test frequency is above 1 GHz.
- f. The initial step in collecting radiated emission data is a receiver peak detector mode pre-scanning the measurement frequency range. Significant peaks are then marked and then Quasi Peak detector mode re-measured.
- g. All readings are Peak unless otherwise stated QP in column of Note. Peak denotes that the Peak reading compliance with the QP Limits and then QP Mode measurement didn't perform.  
(below 1 GHz)
- h. All readings are Peak Mode value unless otherwise stated AVG in column of Note. If the Peak Mode Measured value compliance with the Peak Limits and lower than AVG Limits, the EUT shall be deemed to meet both Peak & AVG Limits and then only Peak Mode was measured, but AVG Mode didn't perform. (above 1 GHz)
- i. For the actual test configuration, please refer to the related Item -EUT Test Photos.

## 4.3 DEVIATION FROM TEST STANDARD

No deviation

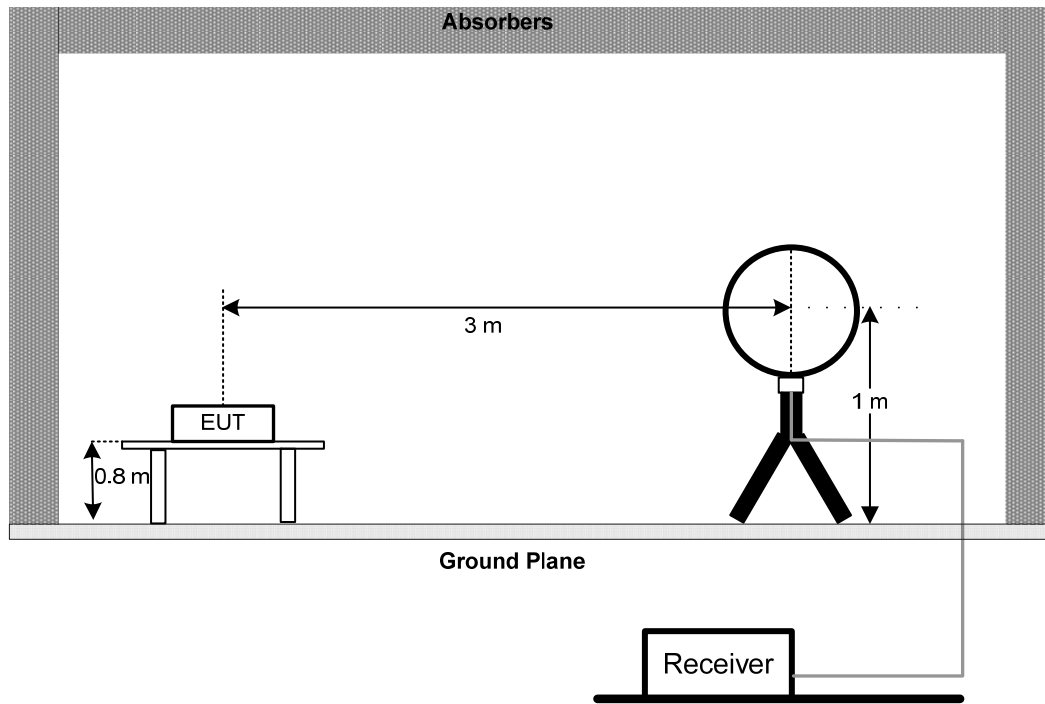
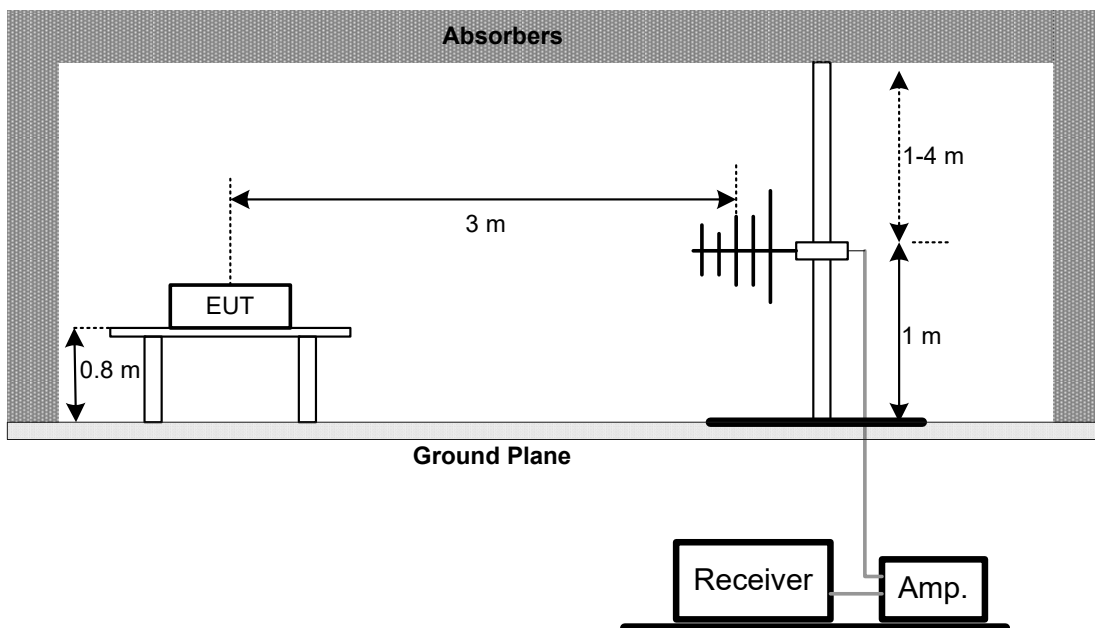
**4.4 TEST SETUP****9 kHz-30 MHz****30 MHz to 1 GHz**

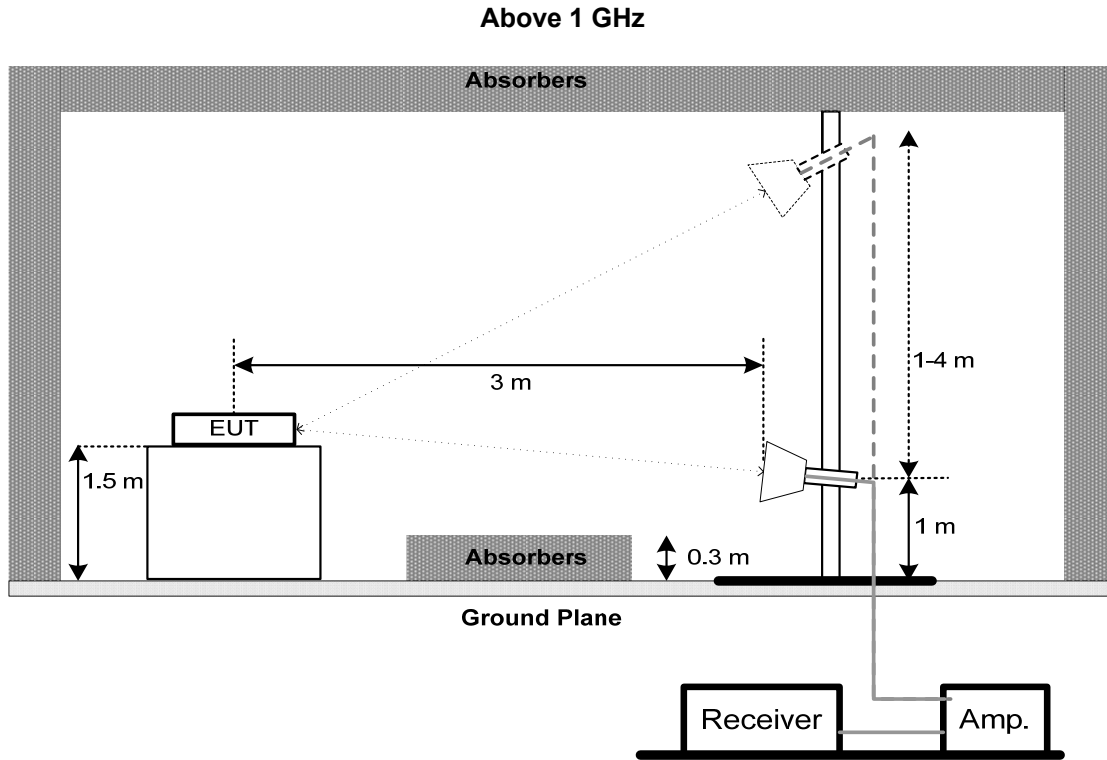

#### 4.5 EUT OPERATION CONDITIONS

The EUT was programmed to be in continuously transmitting mode.

#### 4.6 TEST RESULTS - 9 KHZ TO 30 MHZ

Please refer to the APPENDIX B

Remark:

- (1) Distance extrapolation factor =  $40 \log (\text{specific distance} / \text{test distance})$  (dB).
- (2) Limit line = specific limits (dBuV) + distance extrapolation factor.

#### 4.7 TEST RESULTS - 30 MHZ TO 1000 MHZ

Please refer to the APPENDIX C.

#### 4.8 TEST RESULTS - ABOVE 1000 MHZ

Please refer to the APPENDIX D.

Remark:

- (1) No limit: This is fundamental signal, the judgment is not applicable.  
For fundamental signal judgment was referred to Peak output test.

## 5. BANDWIDTH TEST

### 5.1 LIMIT

FCC Part15, Subpart C (15.247)		
Section	Test Item	Limit
15.247(a)(2)	6 dB Bandwidth	Minimum 500 kHz
	99% Emission Bandwidth	-

### 5.2 TEST PROCEDURE

- a. The EUT was directly connected to the spectrum analyzer and antenna output port as show in the block diagram below.
- b. Spectrum Setting:
  - For 6 dB Bandwidth : RBW= 100 kHz, VBW=300 kHz, Sweep time = auto.
  - For 99% Emission Bandwidth B/G/N-20 Mode: RBW= 300 KHz, VBW=1 MHz, Sweep time = 2.5 ms.
  - For 99% Emission Bandwidth N-40 Mode: RBW= 1 MHz, VBW=3 MHz, Sweep time = 2.5 ms.
- c. The bandwidth was performed in accordance with method 11.8.1 of ANSI C63.10-2013.

### 5.3 DEVIATION FROM STANDARD

No deviation.

### 5.4 TEST SETUP



### 5.5 EUT OPERATION CONDITIONS

The EUT was programmed to be in continuously transmitting mode.

### 5.6 TEST RESULTS

Please refer to the APPENDIX E.

## 6. MAXIMUM OUTPUT POWER TEST

### 6.1 LIMIT

FCC Part15, Subpart C (15.247)		
Section	Test Item	Limit
15.247(b)(3)	Maximum Output Power	1 Watt or 30dBm

### 6.2 TEST PROCEDURE

- The EUT was directly connected to the power meter and antenna output port as show in the block diagram below.
- The maximum conducted output power was performed in accordance with method 11.9.1.3 (for peak power) or 11.9.2.3.1 (for AVG power) of ANSI C63.10-2013.

### 6.3 DEVIATION FROM STANDARD

No deviation.

### 6.4 TEST SETUP



### 6.5 EUT OPERATION CONDITIONS

The EUT was programmed to be in continuously transmitting mode.

### 6.6 TEST RESULTS

Please refer to the APPENDIX F.

## 7. CONDUCTED SPURIOUS EMISSIONS

### 7.1 LIMIT

In any 100 kHz bandwidth outside the frequency band in which the spread spectrum or digitally modulated intentional radiator is operating, the radio frequency power that is produced by the intentional radiator shall be at least 20 dB below that in the 100 kHz bandwidth within the band that contains the highest level of the desired power, based on either an RF conducted or a radiated measurement, provided the transmitter demonstrates compliance with the peak Output Power limits. If the transmitter complies with the Output Power limits based on the use of RMS averaging over a time interval, as permitted under paragraph (b)(3) of this section, the attenuation required under this paragraph shall be 30 dB instead of 20 dB. Attenuation below the general limits specified in Section 15.209(a) is not required.

### 7.2 TEST PROCEDURE

- a. The EUT was directly connected to the spectrum analyzer and antenna output port as show in the block diagram below.
- b. Spectrum Setting: RBW= 100 kHz, VBW=300 kHz, Sweep time = Auto.

### 7.3 DEVIATION FROM STANDARD

No deviation.

### 7.4 TEST SETUP

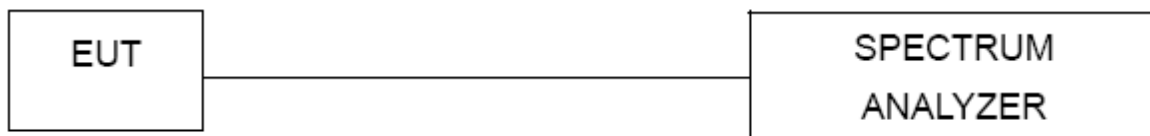

### 7.5 EUT OPERATION CONDITIONS

The EUT was programmed to be in continuously transmitting mode.

### 7.6 TEST RESULTS

Please refer to the APPENDIX G.

## 8. POWER SPECTRAL DENSITY TEST

### 8.1 LIMIT

FCC Part15, Subpart C (15.247)		
Section	Test Item	Limit
15.247(e)	Power Spectral Density	8 dBm (in any 3 kHz)

### 8.2 TEST PROCEDURE

- The EUT was directly connected to the spectrum analyzer and antenna output port as show in the block diagram below.
- Spectrum Setting: RBW=3 kHz, VBW=10 kHz, Sweep time = Auto.
- The Power Spectral Density was performed in accordance with method 11.10.2 of ANSI C63.10-2013.

### 8.3 DEVIATION FROM STANDARD

No deviation.

### 8.4 TEST SETUP



### 8.5 EUT OPERATION CONDITIONS

The EUT was programmed to be in continuously transmitting mode.

### 8.6 TEST RESULTS

Please refer to the APPENDIX H.



## 9. MEASUREMENT INSTRUMENTS LIST

AC Power Line Conducted Emissions					
Item	Kind of Equipment	Manufacturer	Type No.	Serial No.	Calibrated until
1	Line Impedance Stabilisation Network	Schwarzbeck	NNLK 8121	8121-822	Mar. 21, 2021
2	TWO-LINE V-NETWORK	R&S	ENV216	101340	Aug. 23, 2021
3	Test Cable	emci	EMCRG400-BM-NM-10000	170628	Jul. 15, 2021
4	EMI Test Receiver	R&S	ESCI	100082	Mar. 21, 2021
5	50Ω Terminator	SHX	TF2-1G-A	17051602	Mar. 21, 2021
6	50Ω coaxial switch	Anritsu	MP59B	6201750902	Mar. 21, 2021
7	Measurement Software	Farad	EZ-EMC Ver.NB-03A1-01	N/A	N/A

Radiated Emissions - 30 MHz to 1 GHz					
Item	Kind of Equipment	Manufacturer	Type No.	Serial No.	Calibrated until
1	TRILOG Broadband Antenna	Schwarzbeck	VULB 9168	719	Apr. 02, 2021
2	Pre-Amplifier	emci	EMC9135	980400	Mar. 21, 2021
3	MXE EMI Receiver	Keysight	N9038A	MY57150106	Mar. 21, 2021
4	Test Cable	emci	EMC104-SM-SM-7000	170330	Apr. 13, 2021
5	Test Cable	emci	EMC104-SM-SM-1000	170331	Apr. 13, 2021
6	Test Cable	emci	EMC104-SM-NM-3500	170621	Apr. 13, 2021
7	Measurement Software	Farad	EZ-EMC Ver.NB-03A1-01	N/A	N/A

Radiated Emissions - Above 1 GHz					
Item	Kind of Equipment	Manufacturer	Type No.	Serial No.	Calibrated until
1	Double-Ridged Waveguide Horn Antenna	ETS-Lindgren	9120D	00206960	Apr. 02, 2021
2	Pre-Amplifier	emci	EMC012645SE	980421	May. 11, 2021
3	EXA Spectrum Analyzer	Keysight	N9010A	MY56480545	Mar. 21, 2021
4	Test Cable	emci	EMC104-SM-SM-7000	170330	Apr. 13, 2021
5	Test Cable	emci	EMC104-SM-SM-1000	170331	Apr. 13, 2021
6	Test Cable	emci	EMC104-SM-NM-3500	170621	Apr. 13, 2021
7	Measurement Software	Farad	EZ-EMC Ver.NB-03A1-01	N/A	N/A
8	MXE EMI Receiver	Keysight	N9038A	MY57150106	May. 06, 2021
9	Double-Ridged Waveguide Horn Antenna	ETS-Lindgren	3116C	00203919	Jul. 20, 2021
10	Pre-Amplifier	emci	EMC184045SE	980409	Mar. 21, 2021
11	EXA Spectrum Analyzer	Keysight	N9010A	MY56480579	Mar. 21, 2021
12	Test Cable	emci	EMC102-KM-KM-800	170654	Apr. 13, 2021
13	Test Cable	emci	Super Reliable-40G-SS11-7000	W0030860001	Apr. 13, 2021
14	Measurement Software	Farad	EZ-EMC Ver.NB-03A1-01	N/A	N/A

Bandwidth					
Item	Kind of Equipment	Manufacturer	Type No.	Serial No.	Calibrated until
1	Spectrum Analyzer	R&S	FSP40	100626	May. 06, 2021

Maximum Output Power					
Item	Kind of Equipment	Manufacturer	Type No.	Serial No.	Calibrated until
1	Peak Power Analyze	Keysight	8990B	MY51000507	Mar. 21, 2021
2	Wideband Power Sensor	Keysight	N9123A	MY58310003	Mar. 21, 2021

Antenna Conducted Spurious Emissions					
Item	Kind of Equipment	Manufacturer	Type No.	Serial No.	Calibrated until
1	Spectrum Analyzer	R&S	FSP40	100626	May. 06, 2021

Power Spectral Density					
Item	Kind of Equipment	Manufacturer	Type No.	Serial No.	Calibrated until
1	Spectrum Analyzer	R&S	FSP40	100626	May. 06, 2021

Remark: "N/A" denotes no model name, serial no. or calibration specified.

All calibration period of equipment list is one year.

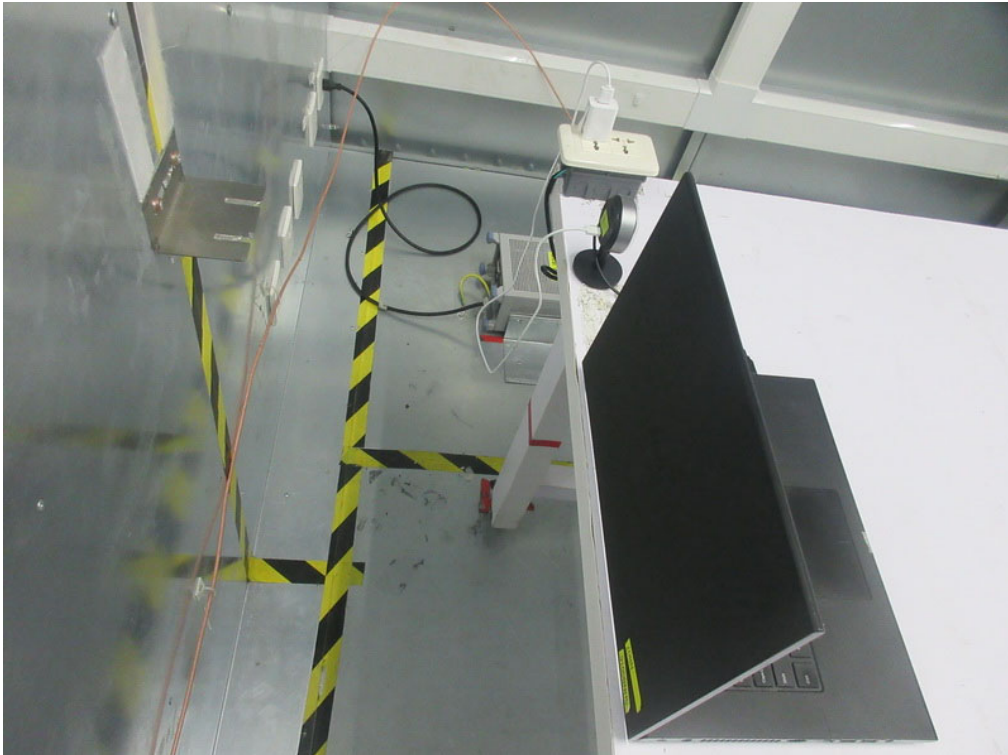
**10. EUT TEST PHOTO****Conducted Emissions Test Photos**

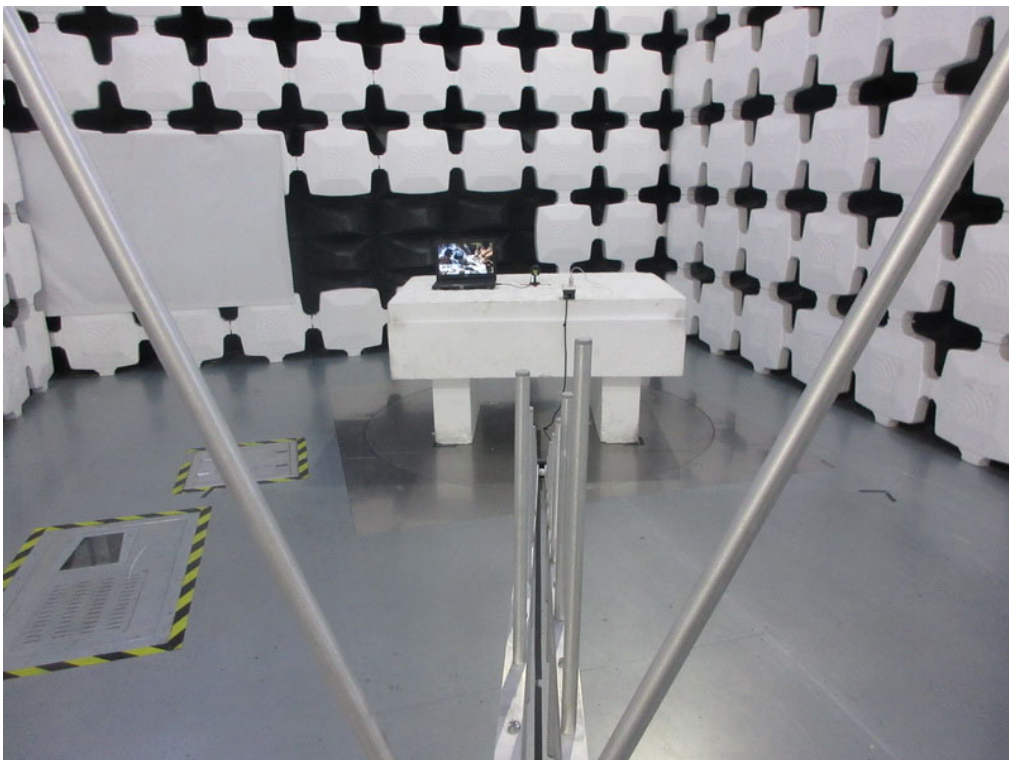
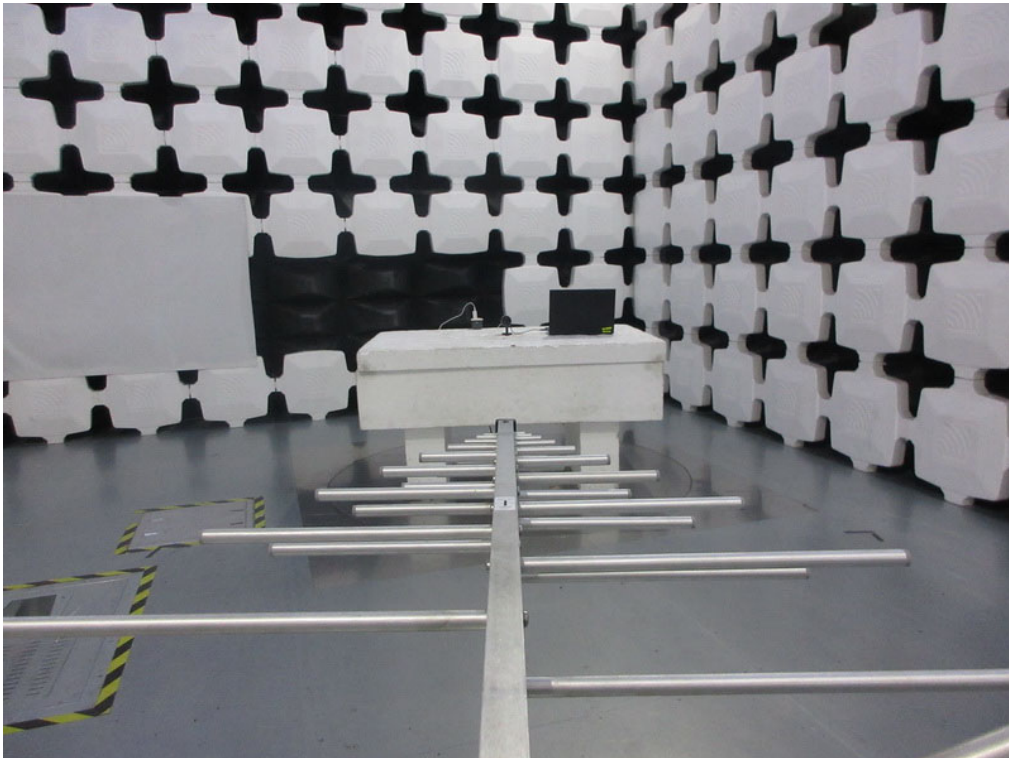
**Radiated Emissions Test Photos****30 MHz to 1 GHz**

**Radiated Emissions Test Photos**  
**Above 1 GHz**

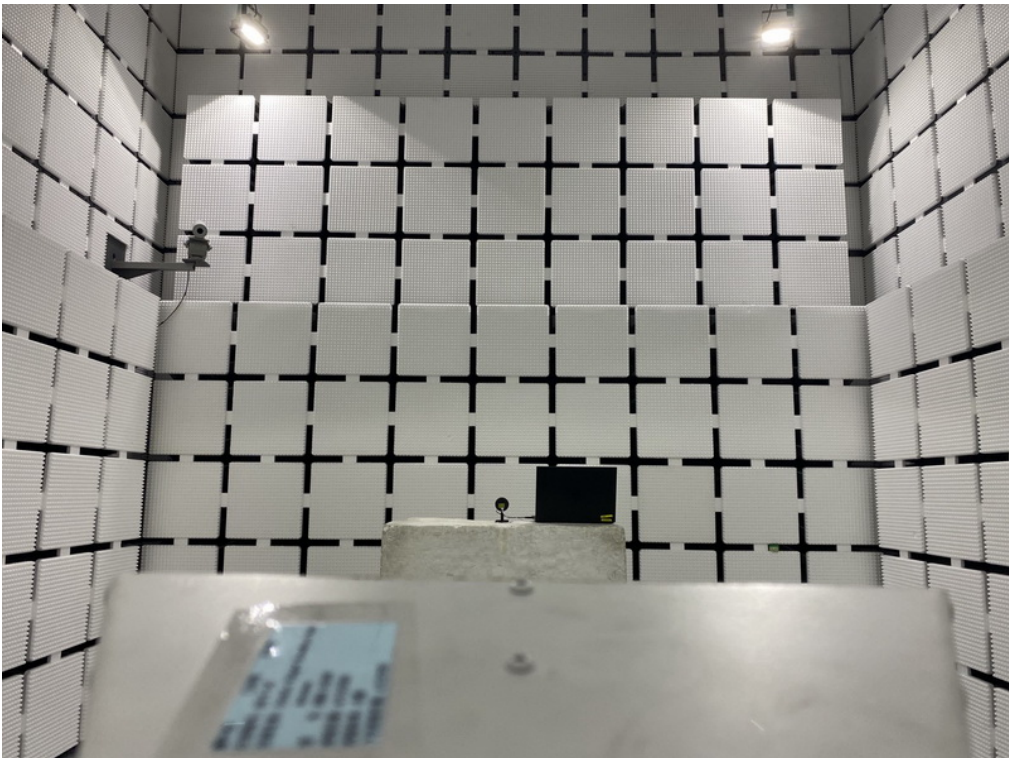
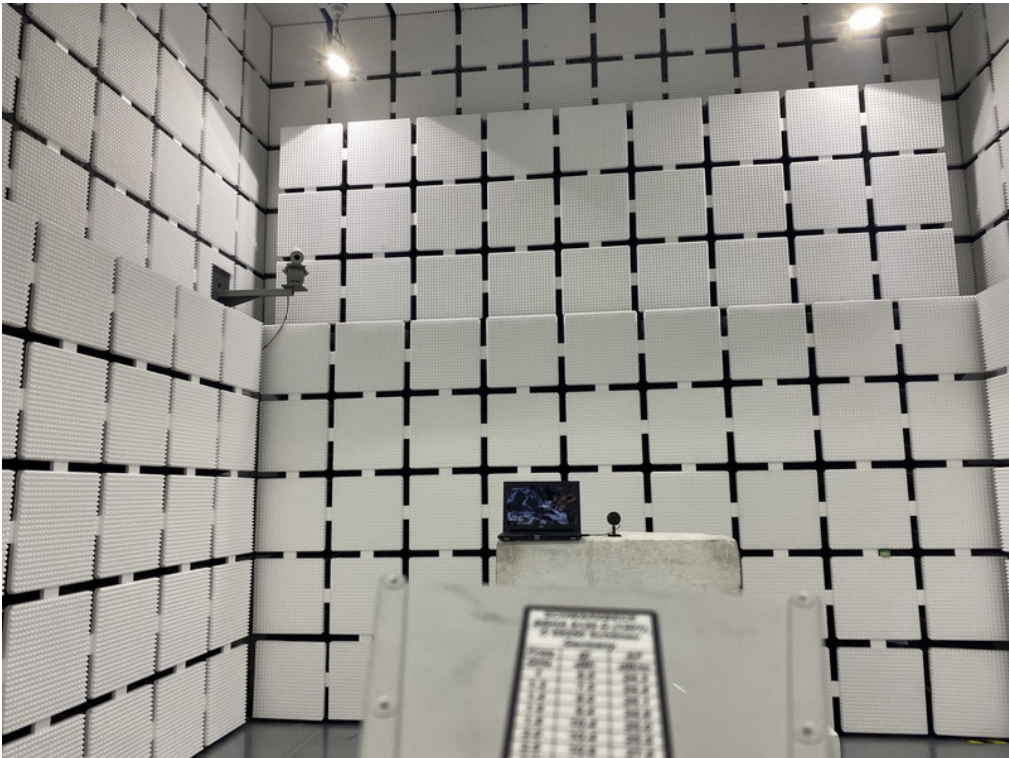

## **APPENDIX A - AC POWER LINE CONDUCTED EMISSIONS**

Test Mode: TX G Mode Channel 06

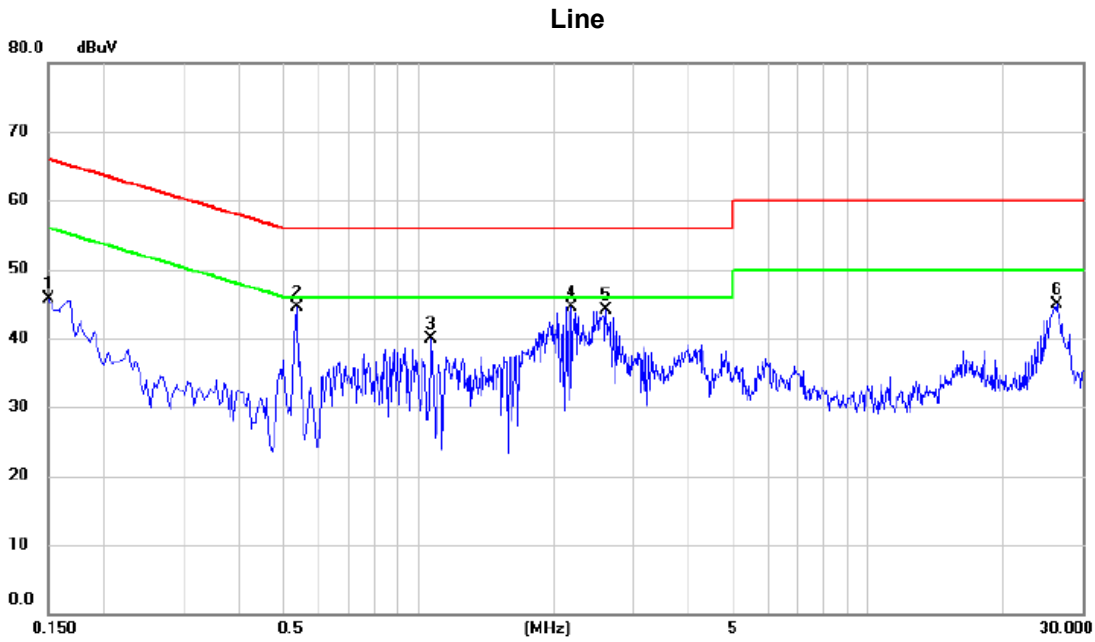

No.	Mk.	Freq. MHz	Reading Level dBuV	Correct Factor dB	Measure- ment dBuV	Limit dBuV	Margin dB	Detector	Comment
1		0.1500	36.03	9.71	45.74	66.00	-20.26	peak	
2		0.5370	34.74	9.80	44.54	56.00	-11.46	peak	
3		1.0680	30.03	9.84	39.87	56.00	-16.13	peak	
4	*	2.1840	34.64	9.91	44.55	56.00	-11.45	peak	
5		2.6204	34.11	9.93	44.04	56.00	-11.96	peak	
6		26.3850	34.27	10.70	44.97	60.00	-15.03	peak	

**REMARKS:**

- (1) Measurement Value = Reading Level + Correct Factor.
- (2) Margin Level = Measurement Value - Limit Value.

Test Mode: TX G Mode Channel 06

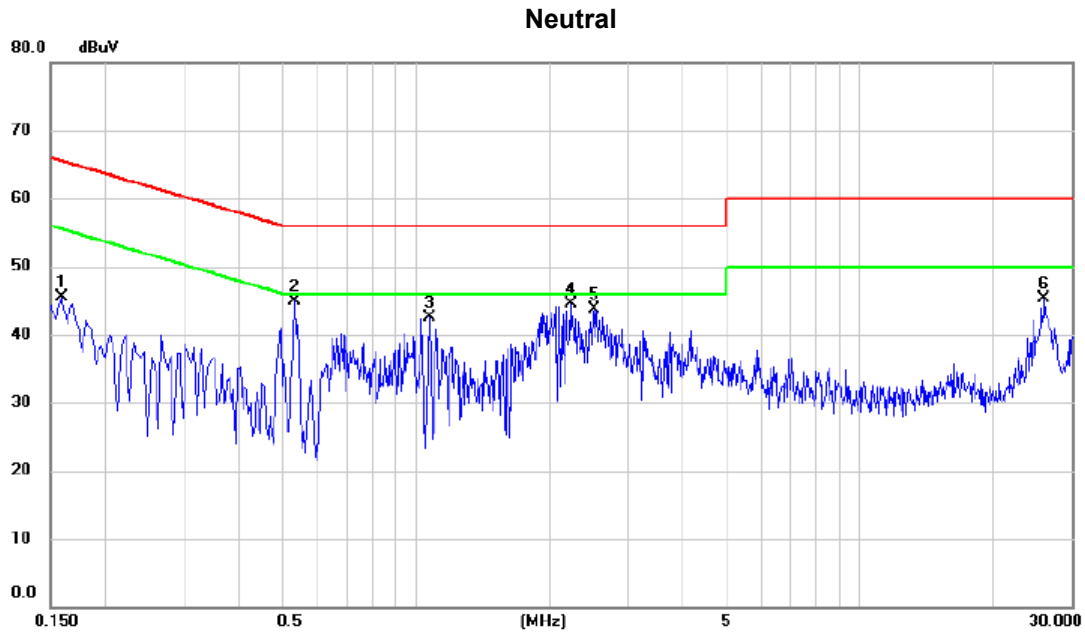

No.	Mk.	Freq. MHz	Reading Level dBuV	Correct Factor dB	Measure- ment dBuV	Limit dBuV	Margin dB	Detector	Comment
1		0.1590	35.83	9.69	45.52	65.52	-20.00	peak	
2	*	0.5325	35.19	9.78	44.97	56.00	-11.03	peak	
3		1.0725	32.59	9.82	42.41	56.00	-13.59	peak	
4		2.2335	34.62	9.90	44.52	56.00	-11.48	peak	
5		2.5260	33.78	9.91	43.69	56.00	-12.31	peak	
6		26.0250	34.54	10.80	45.34	60.00	-14.66	peak	

**REMARKS:**

- (1) Measurement Value = Reading Level + Correct Factor.
- (2) Margin Level = Measurement Value - Limit Value.



## **APPENDIX B - RADIATED EMISSION - 9 KHZ TO 30 MHZ**

Note: The measured value have enough margin over 20dB than the limit, therefore they are not reported.

**APPENDIX C - RADIATED EMISSION - 30 MHZ TO 1000 MHZ**

Test Mode: TX G Mode Channel 06

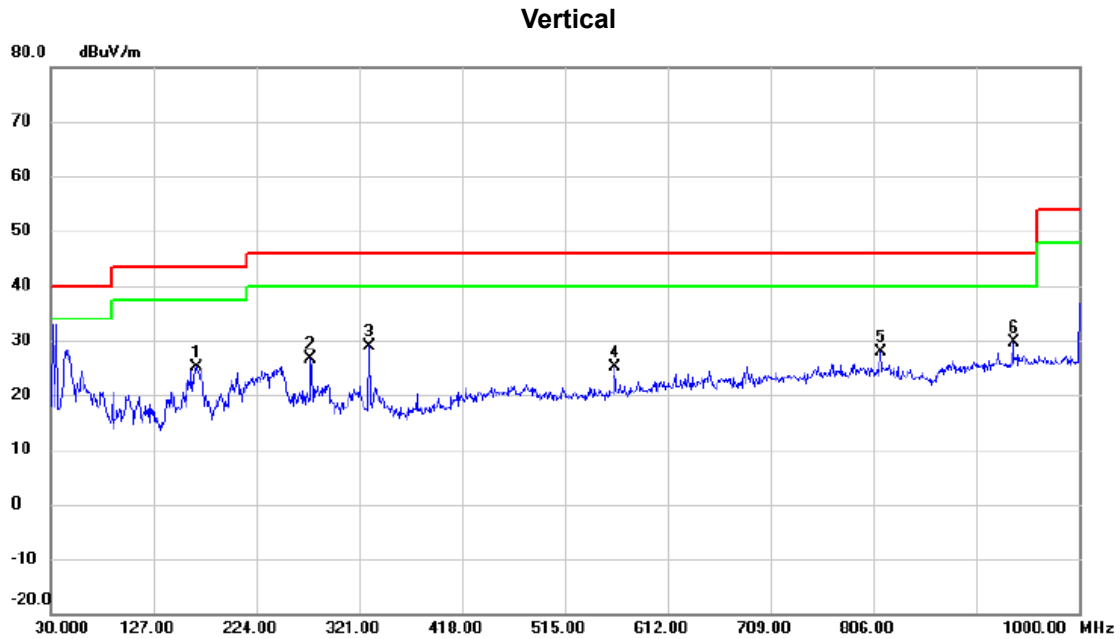

No.	Mk.	Freq. MHz	Reading Level dBuV	Correct Factor dB	Measure- ment dBuV/m	Limit dBuV/m	Margin dB	Detector	Comment
1		167.7400	42.41	-17.21	25.20	43.50	-18.30	peak	
2		275.4100	44.20	-17.53	26.67	46.00	-19.33	peak	
3		330.7000	45.19	-16.19	29.00	46.00	-17.00	peak	
4		562.5300	37.21	-11.96	25.25	46.00	-20.75	peak	
5		812.7900	36.39	-8.47	27.92	46.00	-18.08	peak	
6	*	937.9200	36.95	-7.33	29.62	46.00	-16.38	peak	

**REMARKS:**

- (1) Measurement Value = Reading Level + Correct Factor.
- (2) Margin Level = Measurement Value - Limit Value.

Test Mode: TX G Mode Channel 06

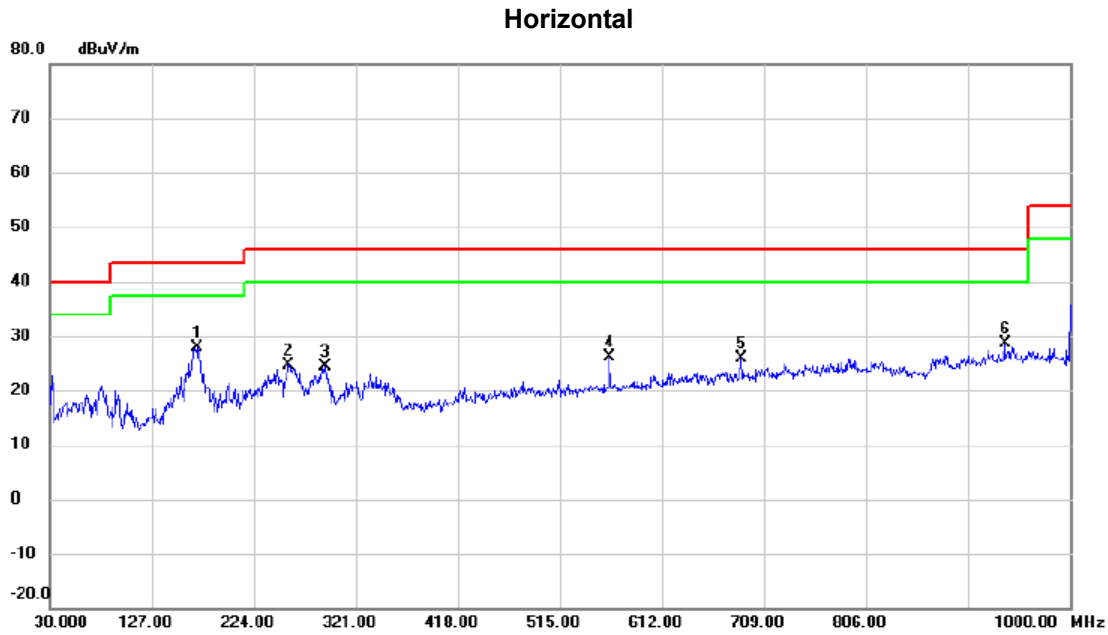

No.	Mk.	Freq. MHz	Reading Level dBuV	Correct Factor dB	Measure- ment dBuV/m	Limit dBuV/m	Margin dB	Detector	Comment
1	*	169.6800	45.25	-17.28	27.97	43.50	-15.53	peak	
2		256.9800	43.04	-18.35	24.69	46.00	-21.31	peak	
3		291.9000	41.60	-17.10	24.50	46.00	-21.50	peak	
4		562.5300	38.06	-11.96	26.10	46.00	-19.90	peak	
5		687.6600	35.90	-10.05	25.85	46.00	-20.15	peak	
6		937.9200	36.06	-7.33	28.73	46.00	-17.27	peak	

**REMARKS:**

- (1) Measurement Value = Reading Level + Correct Factor.
- (2) Margin Level = Measurement Value - Limit Value.

**APPENDIX D - RADIATED EMISSION- ABOVE 1000 MHZ**

Test Mode: TX B Mode 2412 MHz

Vertical

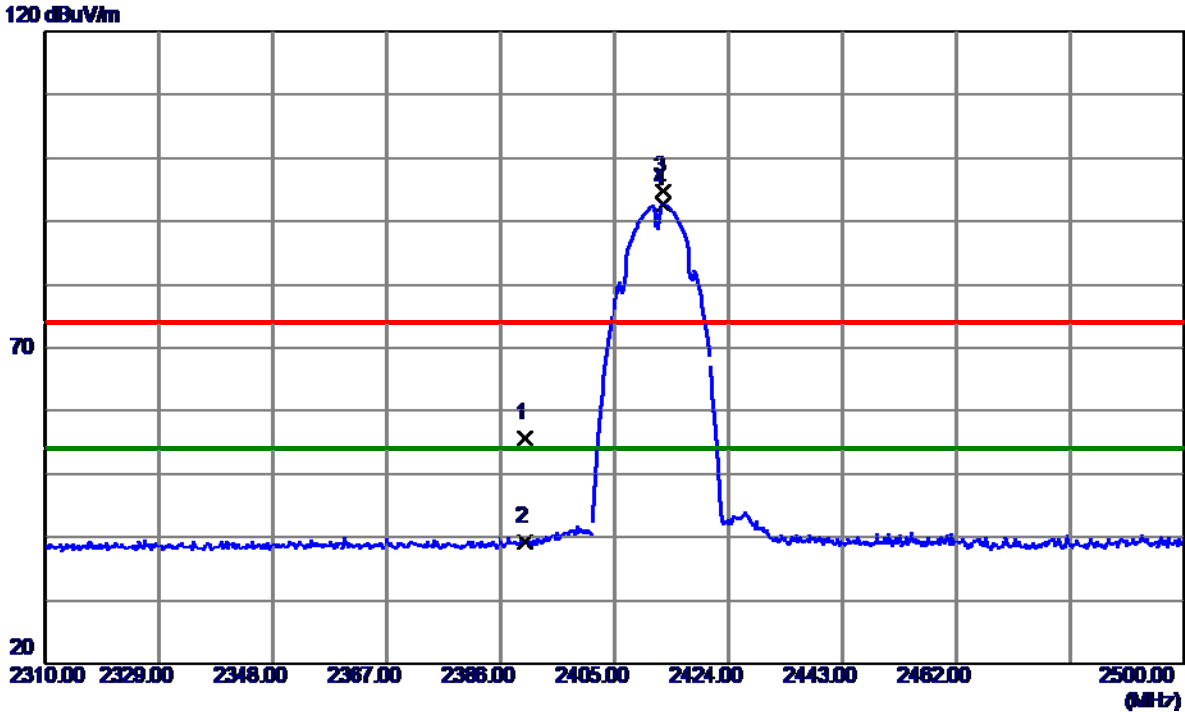

No.	Freq. MHz	Reading Level dBuV/m	Correct Factor dB	Measure ment dBuV/m	Limit dBuV/m	Margin dB	Detector	Comment
1	2390.0000	23.79	31.74	55.53	74.00	-18.47	Peak	
2	2390.0000	7.45	31.74	39.19	54.00	-14.81	AVG	
3	2412.9800	63.17	31.72	94.89	74.00	20.89	Peak	No limit
4 *	2412.9800	60.98	31.72	92.70	54.00	38.70	AVG	No limit

REMARKS:

- (1) Measurement Value = Reading Level + Correct Factor.
- (2) Margin Level = Measurement Value - Limit Value.

Test Mode: TX B Mode 2412 MHz

### Vertical

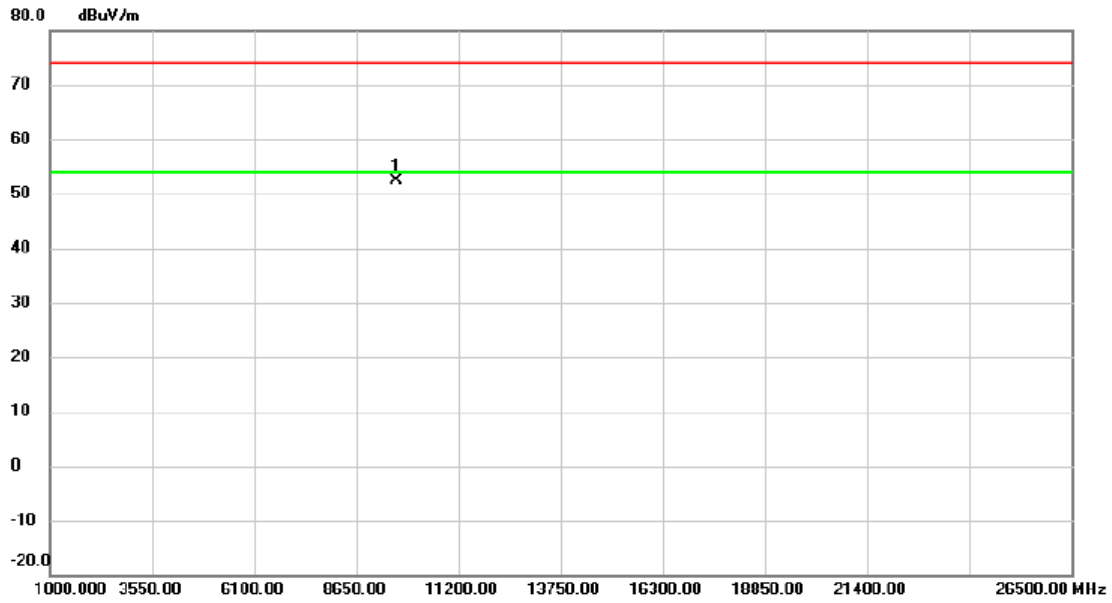

No.	Mk.	Freq. MHz	Reading Level dBuV	Correct Factor dB	Measure- ment dBuV/m	Limit dBuV/m	Margin dB	Detector	Comment
1	*	9648.288	51.90	0.60	52.50	74.00	-21.50	peak	

**REMARKS:**

- (1) Measurement Value = Reading Level + Correct Factor.
- (2) Margin Level = Measurement Value - Limit Value.

Test Mode: TX B Mode 2412 MHz

### Horizontal

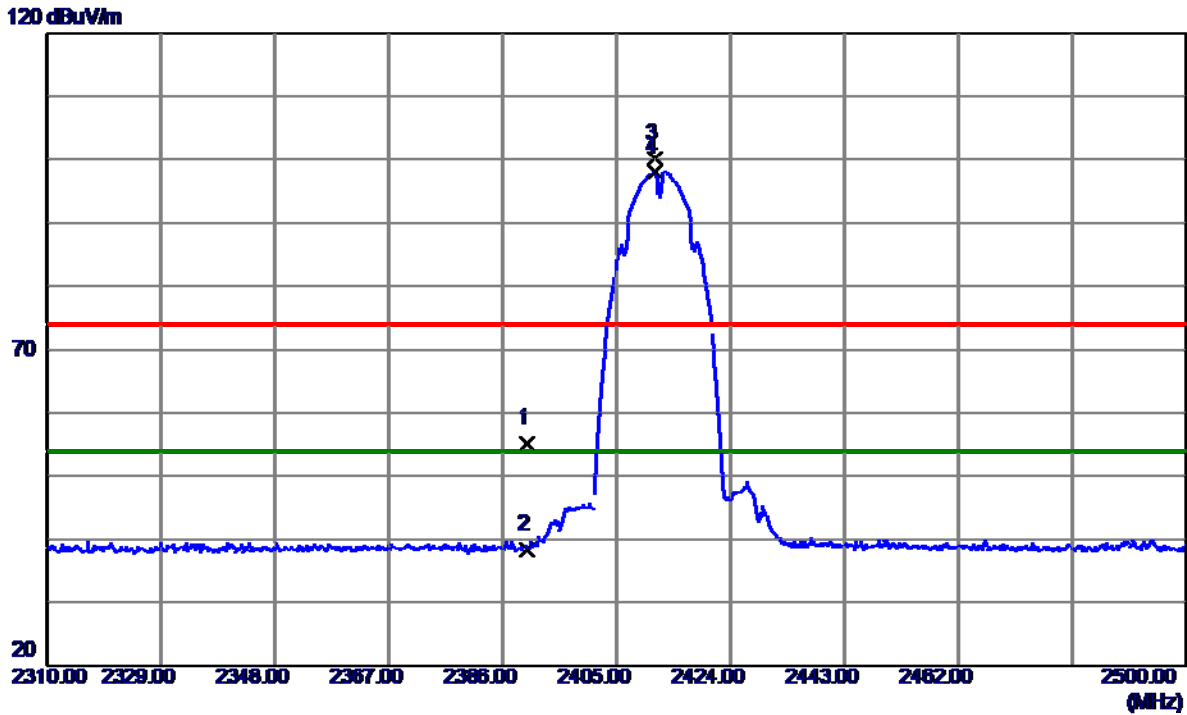

No.	Freq. MHz	Reading Level dBuV/m	Correct Factor dB	Measure ment dBuV/m	Limit dBuV/m	Margin dB	Detector	Comment
1	2390.0000	23.54	31.74	55.28	74.00	-18.72	Peak	
2	2390.0000	6.67	31.74	38.41	54.00	-15.59	AVG	
3	2411.2700	68.51	31.72	100.23	74.00	26.23	Peak	No limit
4 *	2411.2700	66.34	31.72	98.06	54.00	44.06	AVG	No limit

**REMARKS:**

(1) Measurement Value = Reading Level + Correct Factor.

(2) Margin Level = Measurement Value - Limit Value.



Test Mode: TX B Mode 2412 MHz

### Horizontal

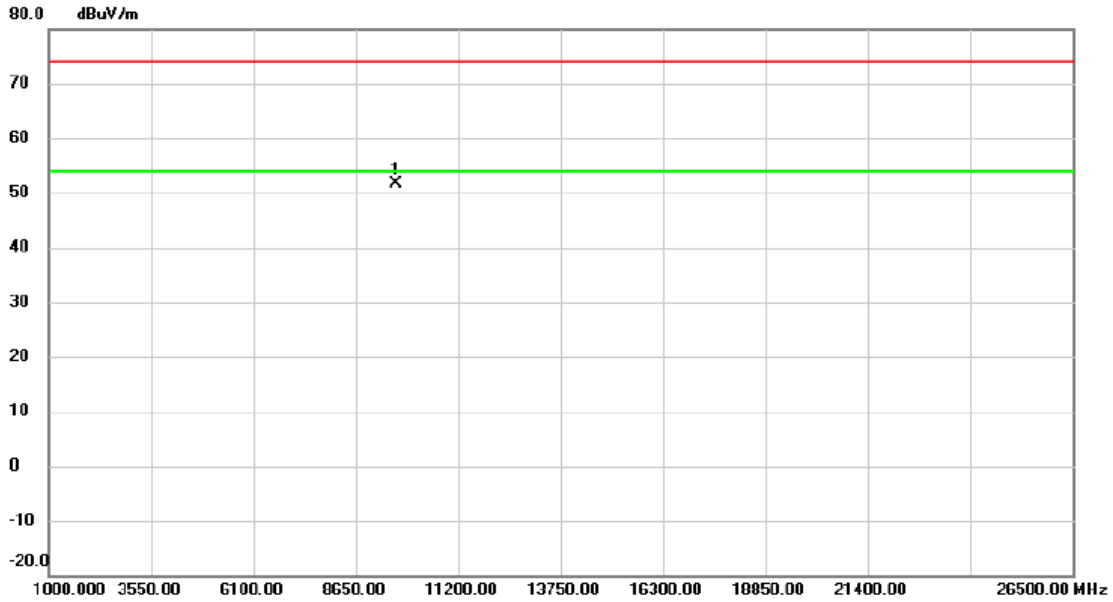

No.	Mk.	Freq.	Reading Level	Correct Factor	Measurement	Limit	Margin	Detector	Comment
		MHz	dBuV	dB	dBuV/m	dBuV/m	dB		
1	*	9648.048	51.01	0.60	51.61	74.00	-22.39	peak	

**REMARKS:**

- (1) Measurement Value = Reading Level + Correct Factor.
- (2) Margin Level = Measurement Value - Limit Value.

Test Mode: TX B Mode 2437 MHz

Vertical

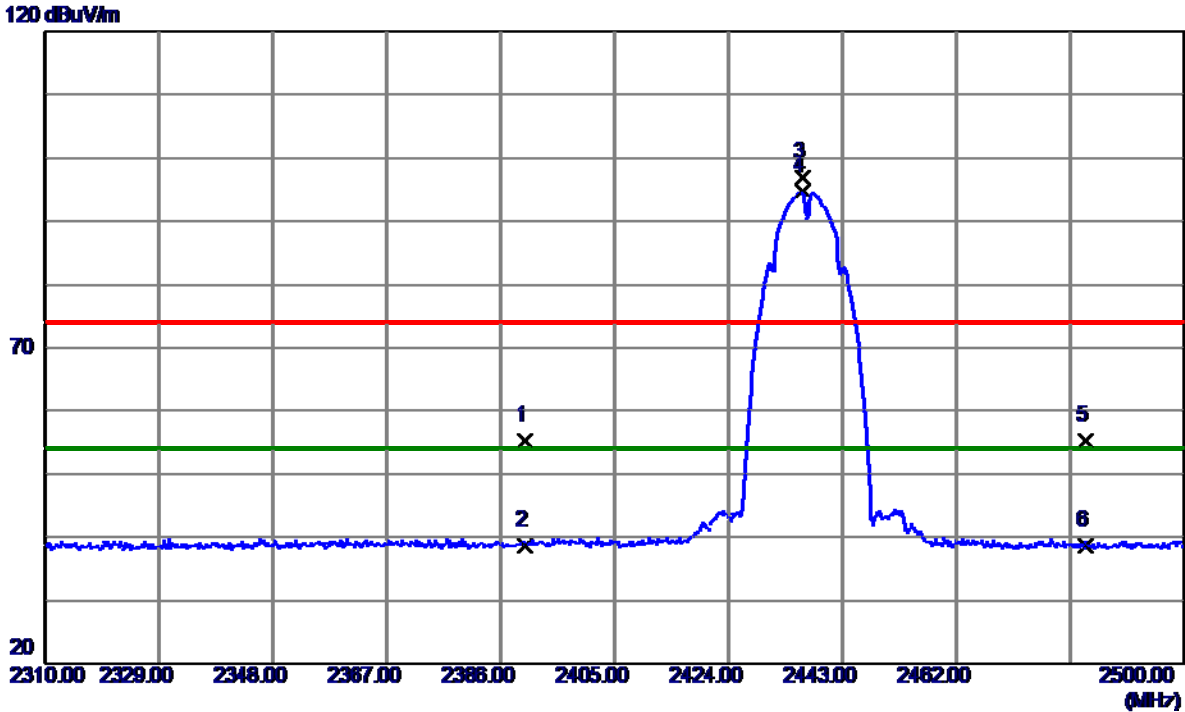

No.	Freq. MHz	Reading Level dBuV/m	Correct Factor dB	Measure ment dBuV/m	Limit dBuV/m	Margin dB	Detector	Comment
1	2390.0000	23.53	31.74	55.27	74.00	-18.73	Peak	
2	2390.0000	6.94	31.74	38.68	54.00	-15.32	AVG	
3	2436.2549	65.31	31.72	97.03	74.00	23.03	Peak	No limit
4 *	2436.2549	63.00	31.72	94.72	54.00	40.72	AVG	No limit
5	2483.5000	23.52	31.71	55.23	74.00	-18.77	Peak	
6	2483.5000	6.95	31.71	38.66	54.00	-15.34	AVG	

REMARKS:

- (1) Measurement Value = Reading Level + Correct Factor.
- (2) Margin Level = Measurement Value - Limit Value.

Test Mode: TX B Mode 2437 MHz

### Vertical

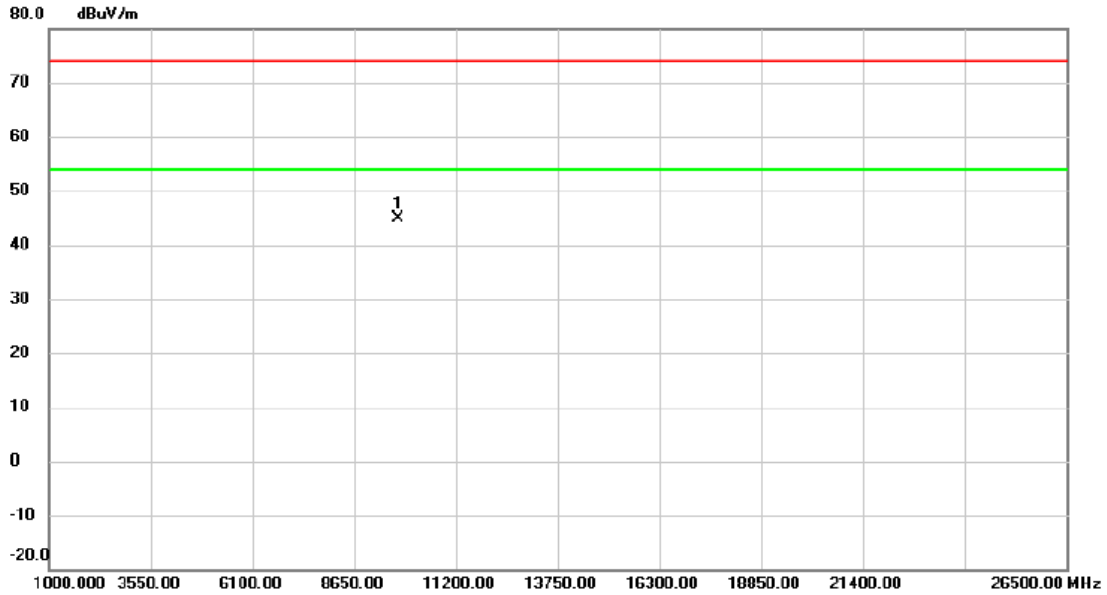

No.	Mk.	Freq. MHz	Reading Level dBuV	Correct Factor dB	Measure- ment dBuV/m	Limit dBuV/m	Margin dB	Detector	Comment
1	*	9748.055	43.77	0.99	44.76	74.00	-29.24	peak	

**REMARKS:**

- (1) Measurement Value = Reading Level + Correct Factor.
- (2) Margin Level = Measurement Value - Limit Value.

Test Mode: TX B Mode 2437 MHz

### Horizontal

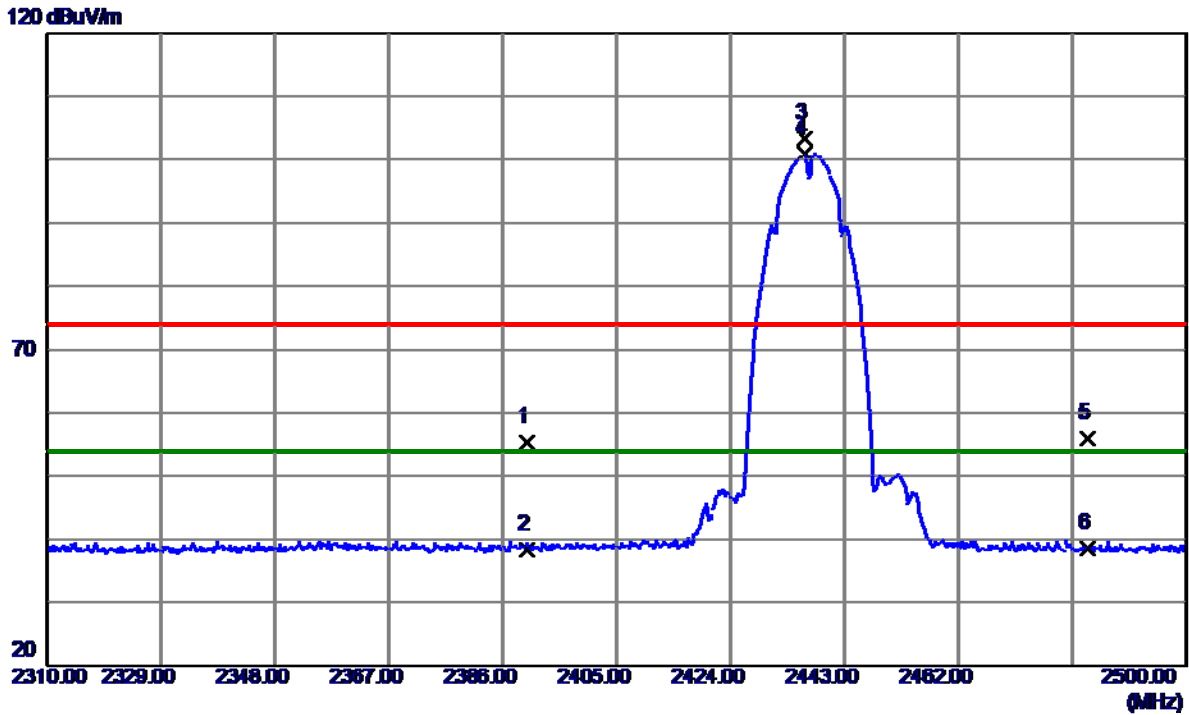

No.	Freq. MHz	Reading Level dBuV/m	Correct Factor dB	Measure ment dBuV/m	Limit dBuV/m	Margin dB	Detector	Comment
1	2390.0000	23.57	31.74	55.31	74.00	-18.69	Peak	
2	2390.0000	6.62	31.74	38.36	54.00	-15.64	AVG	
3	2436.3500	71.65	31.72	103.37	74.00	29.37	Peak	No limit
4 *	2436.3500	69.30	31.72	101.02	54.00	47.02	AVG	No limit
5	2483.5000	24.22	31.71	55.93	74.00	-18.07	Peak	
6	2483.5000	6.90	31.71	38.61	54.00	-15.39	AVG	

**REMARKS:**

(1) Measurement Value = Reading Level + Correct Factor.

(2) Margin Level = Measurement Value - Limit Value.

Test Mode: TX B Mode 2437 MHz

### Horizontal

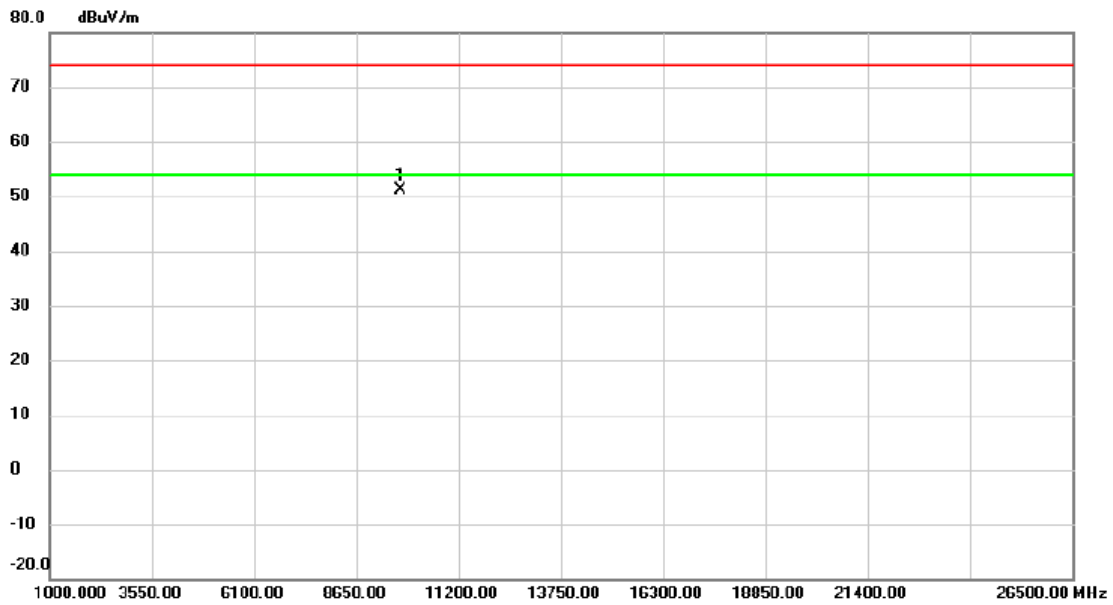

No.	Mk.	Freq. MHz	Reading Level dBuV	Correct Factor dB	Measure- ment dBuV/m	Limit dBuV/m	Margin dB	Detector	Comment
1	*	9748.205	50.26	0.99	51.25	74.00	-22.75	peak	

**REMARKS:**

- (1) Measurement Value = Reading Level + Correct Factor.
- (2) Margin Level = Measurement Value - Limit Value.

Test Mode: TX B Mode 2462 MHz

**Vertical**

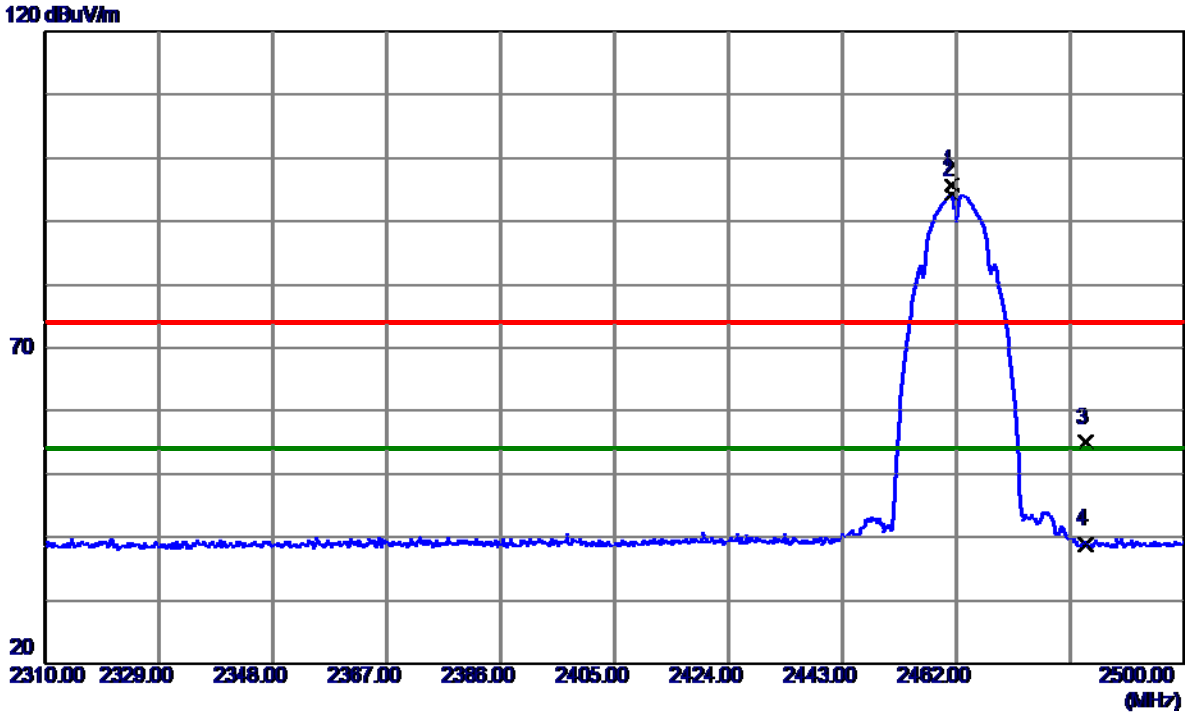

No.	Freq. MHz	Reading Level dBuV/m	Correct Factor dB	Measure ment dBuV/m	Limit dBuV/m	Margin dB	Detector	Comment
1	2461.2400	64.10	31.71	95.81	74.00	21.81	Peak	No limit
2 *	2461.2400	62.51	31.71	94.22	54.00	40.22	AVG	No limit
3	2483.5000	23.19	31.71	54.90	74.00	-19.10	Peak	
4	2483.5000	7.00	31.71	38.71	54.00	-15.29	AVG	

**REMARKS:**

- (1) Measurement Value = Reading Level + Correct Factor.
- (2) Margin Level = Measurement Value - Limit Value.

Test Mode: TX B Mode 2462 MHz

**Vertical**

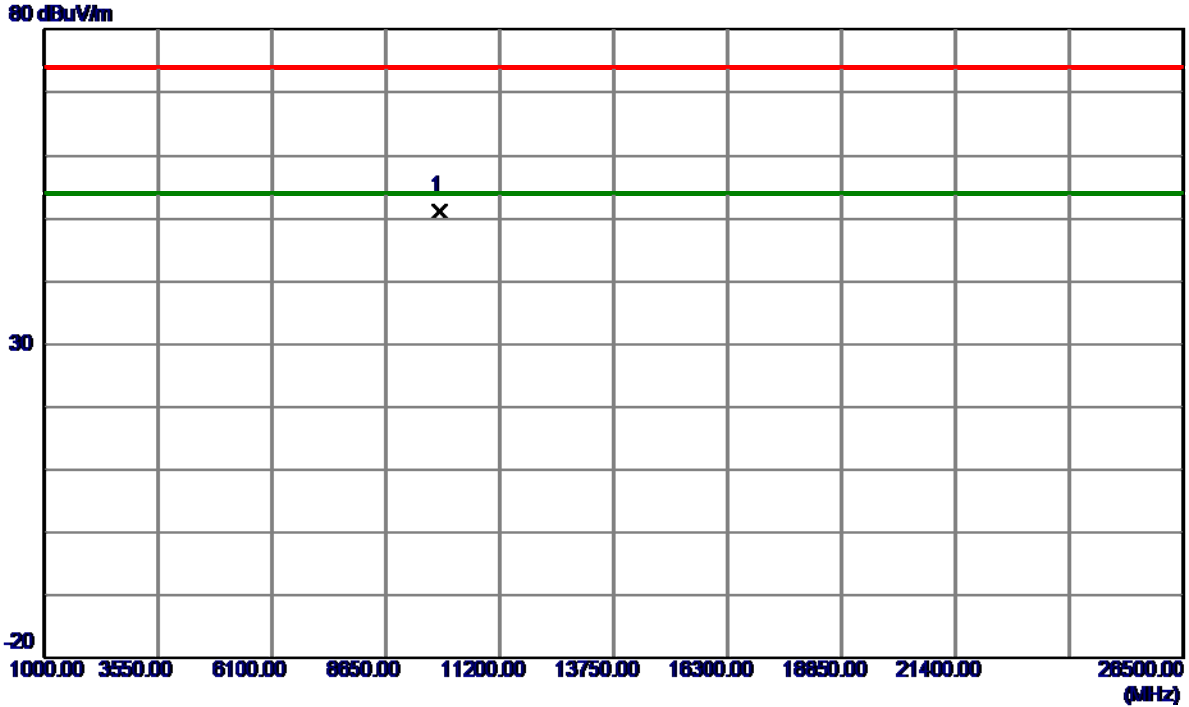

No.	Freq. MHz	Reading Level dBuV/m	Correct Factor dB	Measure ment dBuV/m	Limit dBuV/m	Margin dB	Detector	Comment
1 *	9847.8700	50.09	1.17	51.26	74.00	-22.74	Peak	

REMARKS:  
 (1) Measurement Value = Reading Level + Correct Factor.  
 (2) Margin Level = Measurement Value - Limit Value.

Test Mode: TX B Mode 2462 MHz

### Horizontal

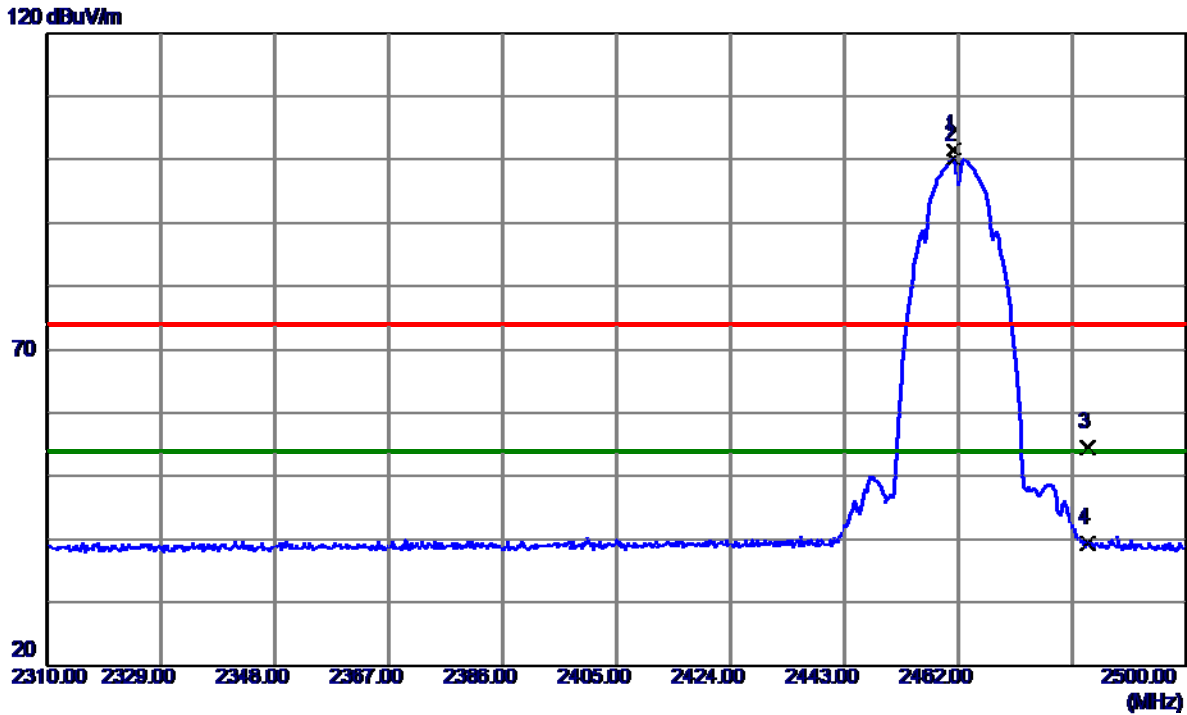

No.	Freq. MHz	Reading Level dBuV/m	Correct Factor dB	Measure ment dBuV/m	Limit dBuV/m	Margin dB	Detector	Comment
1	2461.2400	69.90	31.71	101.61	74.00	27.61	Peak	No limit
2 *	2461.2400	68.36	31.71	100.07	54.00	46.07	AVG	No limit
3	2483.5000	22.87	31.71	54.58	74.00	-19.42	Peak	
4	2483.5000	7.70	31.71	39.41	54.00	-14.59	AVG	

**REMARKS:**

- (1) Measurement Value = Reading Level + Correct Factor.
- (2) Margin Level = Measurement Value - Limit Value.



Test Mode: TX B Mode 2462 MHz

### Horizontal

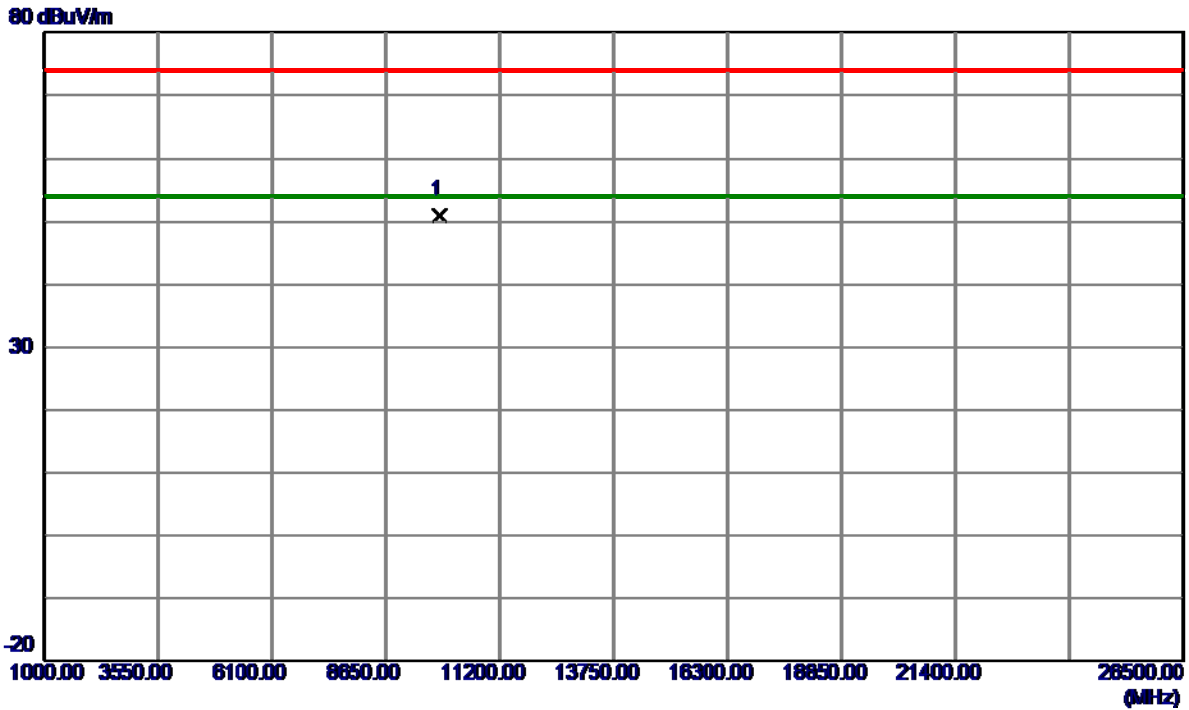

No.	Freq. MHz	Reading Level dBuV/m	Correct Factor dB	Measure ment dBuV/m	Limit dBuV/m	Margin dB	Detector	Comment
1 *	9848.3050	49.79	1.17	50.96	74.00	-23.04	Peak	

REMARKS:

- (1) Measurement Value = Reading Level + Correct Factor.
- (2) Margin Level = Measurement Value - Limit Value.

Test Mode: TX G Mode 2412 MHz

Vertical

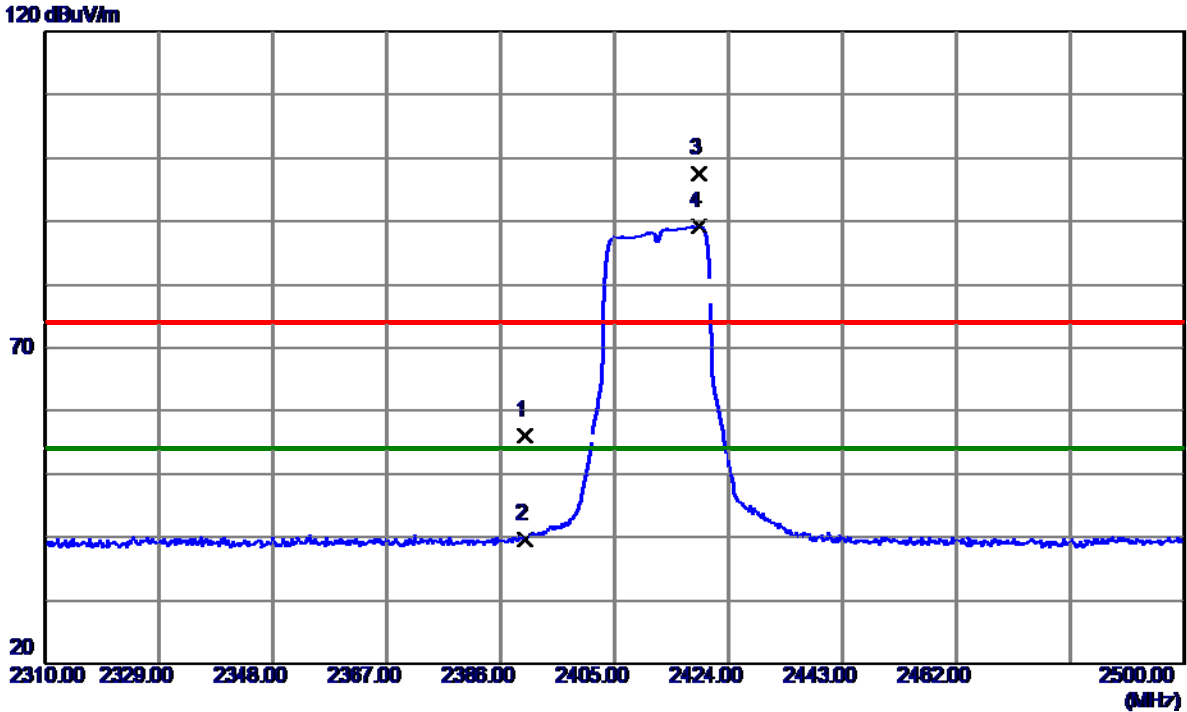

No.	Freq. MHz	Reading Level dBuV/m	Correct Factor dB	Measure ment dBuV/m	Limit dBuV/m	Margin dB	Detector	Comment
1	2390.0000	24.21	31.74	55.95	74.00	-18.05	Peak	
2	2390.0000	7.94	31.74	39.68	54.00	-14.32	AVG	
3	2418.8700	65.85	31.72	97.57	74.00	23.57	Peak	No limit
4 *	2418.8700	57.50	31.72	89.22	54.00	35.22	AVG	No limit

REMARKS:

- (1) Measurement Value = Reading Level + Correct Factor.
- (2) Margin Level = Measurement Value - Limit Value.

Test Mode: TX G Mode 2412 MHz

### Vertical

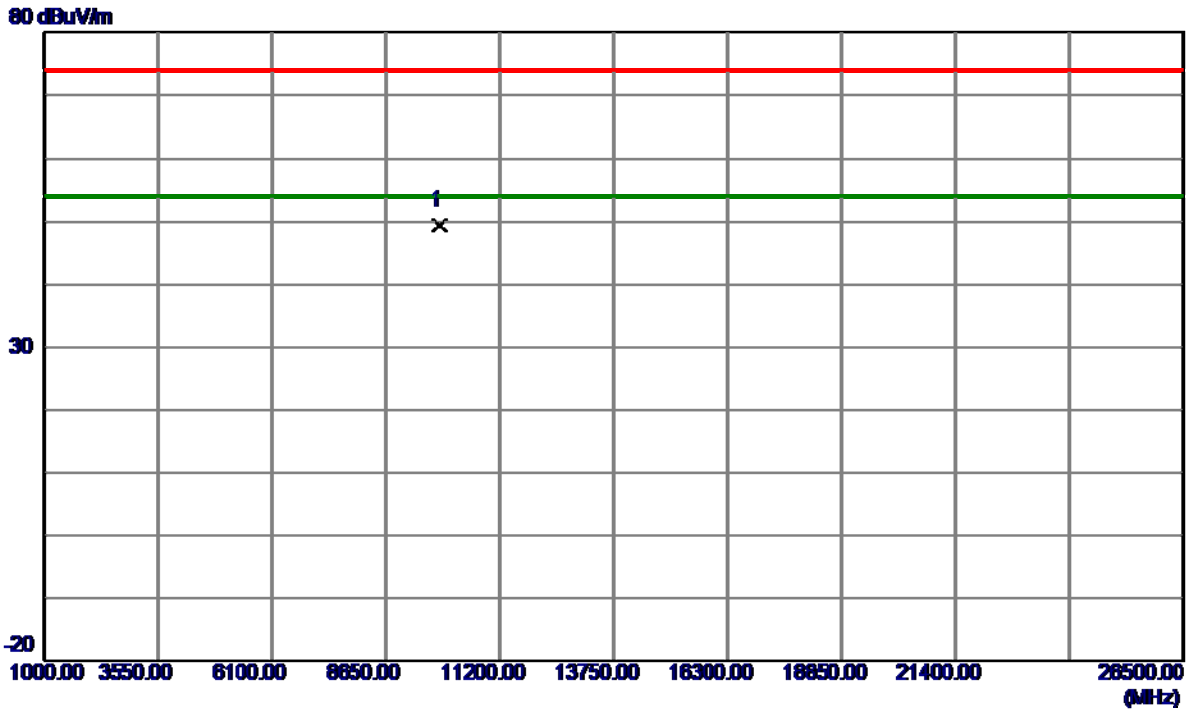

No.	Freq. MHz	Reading Level dBuV/m	Correct Factor dB	Measure ment dBuV/m	Limit dBuV/m	Margin dB	Detector	Comment
1 *	9849.7430	48.23	1.17	49.40	74.00	-24.60	Peak	

**REMARKS:**

- (1) Measurement Value = Reading Level + Correct Factor.
- (2) Margin Level = Measurement Value - Limit Value.

Test Mode: TX G Mode 2412 MHz

### Horizontal

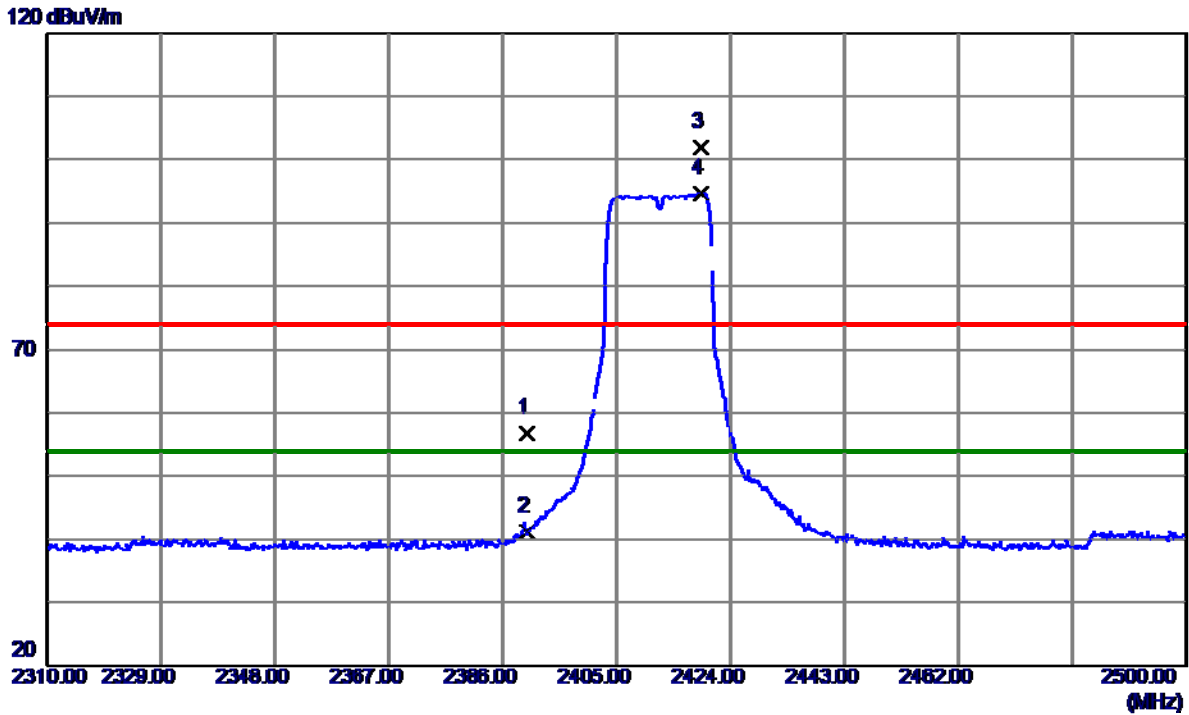

No.	Freq. MHz	Reading Level dBuV/m	Correct Factor dB	Measure ment dBuV/m	Limit dBuV/m	Margin dB	Detector	Comment
1	2390.0000	25.11	31.74	56.85	74.00	-17.15	Peak	
2	2390.0000	9.51	31.74	41.25	54.00	-12.75	AVG	
3	2418.8700	70.19	31.72	101.91	74.00	27.91	Peak	No limit
4 *	2418.8700	62.91	31.72	94.63	54.00	40.63	AVG	No limit

**REMARKS:**

(1) Measurement Value = Reading Level + Correct Factor.

(2) Margin Level = Measurement Value - Limit Value.

Test Mode: TX G Mode 2412 MHz

### Horizontal

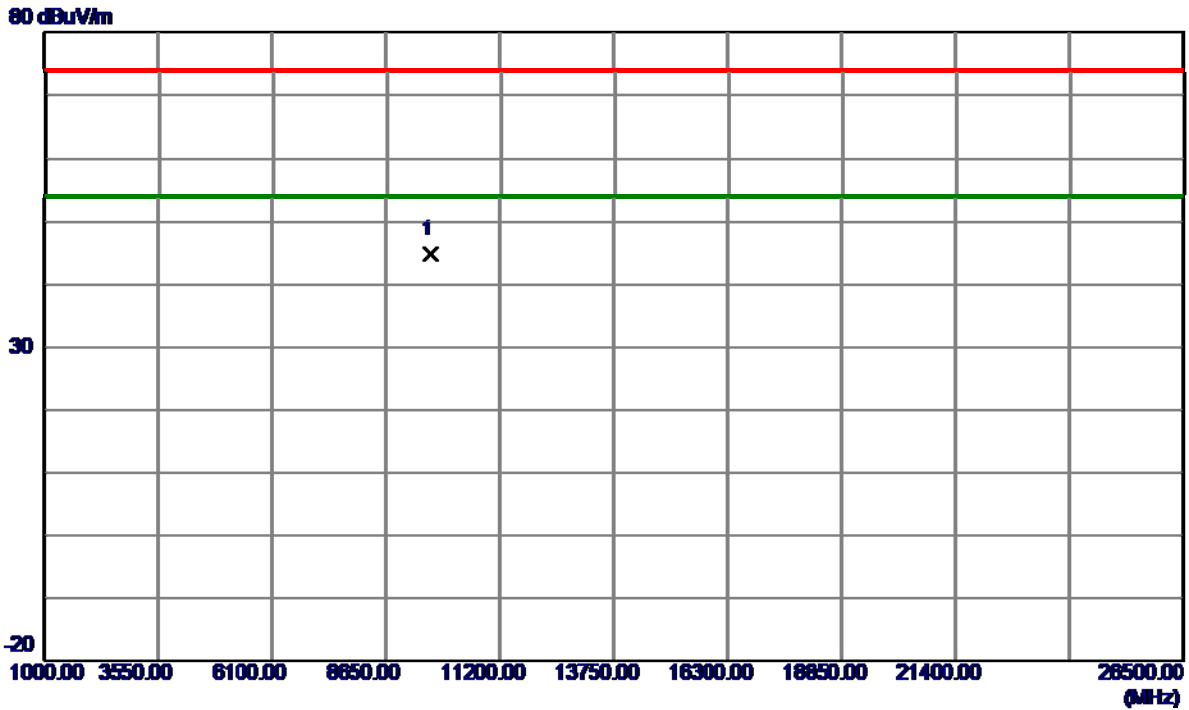

No.	Freq. MHz	Reading Level dBuV/m	Correct Factor dB	Measure ment dBuV/m	Limit dBuV/m	Margin dB	Detector	Comment
1 *	9648.1600	44.20	0.60	44.80	74.00	-29.20	Peak	

REMARKS:

- (1) Measurement Value = Reading Level + Correct Factor.
- (2) Margin Level = Measurement Value - Limit Value.

Test Mode: TX G Mode 2437 MHz

Vertical

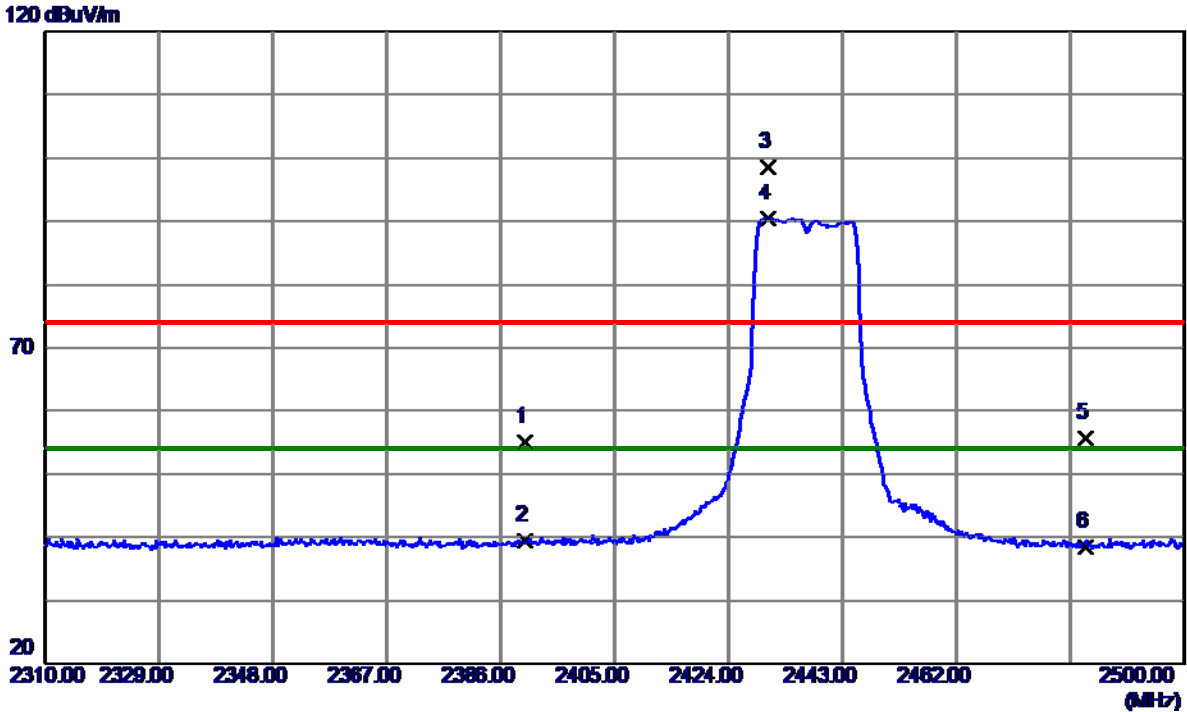

No.	Freq. MHz	Reading Level dBuV/m	Correct Factor dB	Measurement dBuV/m	Limit dBuV/m	Margin dB	Detector	Comment
1	2390.0000	23.31	31.74	55.05	74.00	-18.95	Peak	
2	2390.0000	7.71	31.74	39.45	54.00	-14.55	AVG	
3	2430.4600	66.84	31.72	98.56	74.00	24.56	Peak	No limit
4 *	2430.4600	58.76	31.72	90.48	54.00	36.48	AVG	No limit
5	2483.5000	23.87	31.71	55.58	74.00	-18.42	Peak	
6	2483.5000	6.73	31.71	38.44	54.00	-15.56	AVG	

REMARKS:

- (1) Measurement Value = Reading Level + Correct Factor.
- (2) Margin Level = Measurement Value - Limit Value.

Test Mode: TX G Mode 2437 MHz

**Vertical**

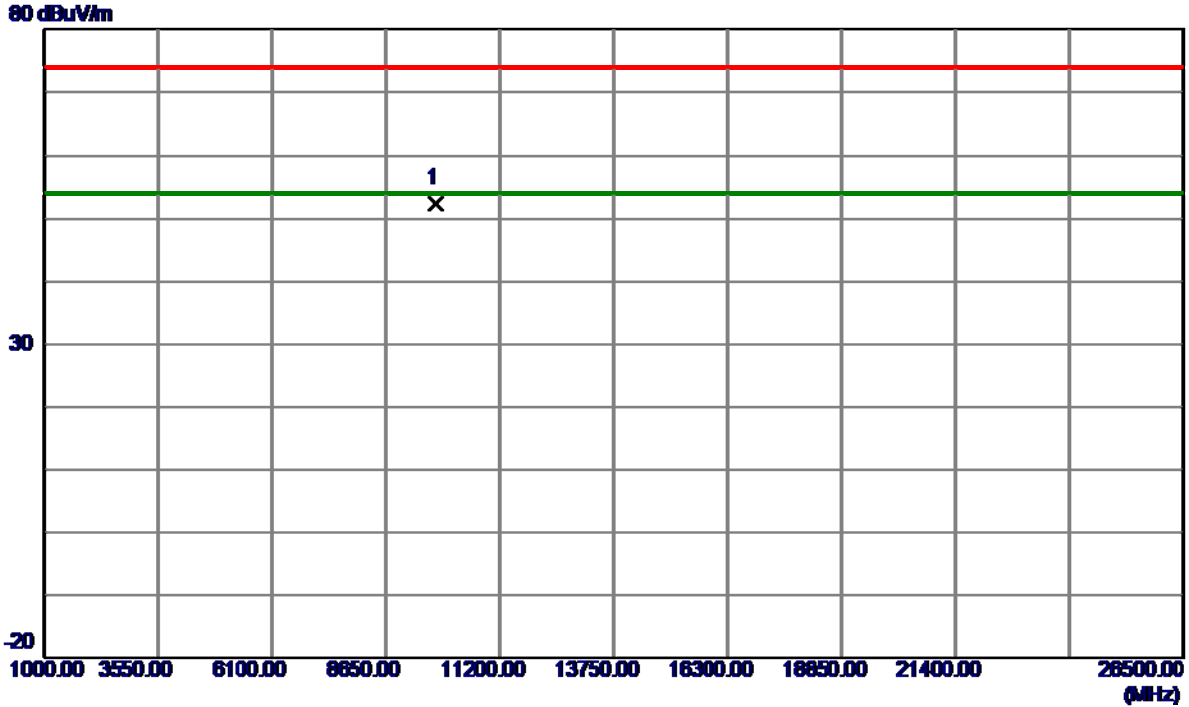

No.	Freq. MHz	Reading Level dBuV/m	Correct Factor dB	Measure ment dBuV/m	Limit dBuV/m	Margin dB	Detector	Comment
1 *	9748.0130	51.40	0.99	52.39	74.00	-21.61	Peak	

**REMARKS:**

- (1) Measurement Value = Reading Level + Correct Factor.
- (2) Margin Level = Measurement Value - Limit Value.

Test Mode: TX G Mode 2437 MHz

### Horizontal

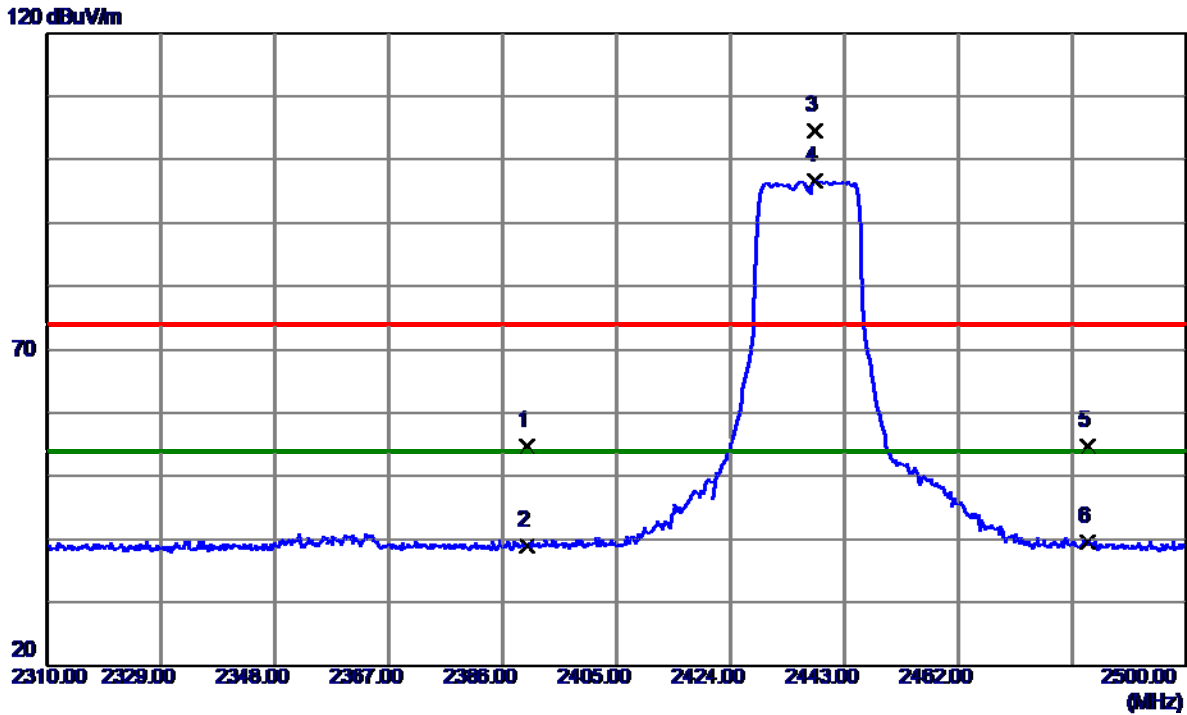

No.	Freq. MHz	Reading Level dBuV/m	Correct Factor dB	Measure ment dBuV/m	Limit dBuV/m	Margin dB	Detector	Comment
1	2390.0000	23.15	31.74	54.89	74.00	-19.11	Peak	
2	2390.0000	7.27	31.74	39.01	54.00	-14.99	AVG	
3	2437.8700	72.95	31.72	104.67	74.00	30.67	Peak	No limit
4 *	2437.8700	64.90	31.72	96.62	54.00	42.62	AVG	No limit
5	2483.5000	23.03	31.71	54.74	74.00	-19.26	Peak	
6	2483.5000	7.86	31.71	39.57	54.00	-14.43	AVG	

**REMARKS:**

- (1) Measurement Value = Reading Level + Correct Factor.
- (2) Margin Level = Measurement Value - Limit Value.



Test Mode: TX G Mode 2437 MHz

### Horizontal

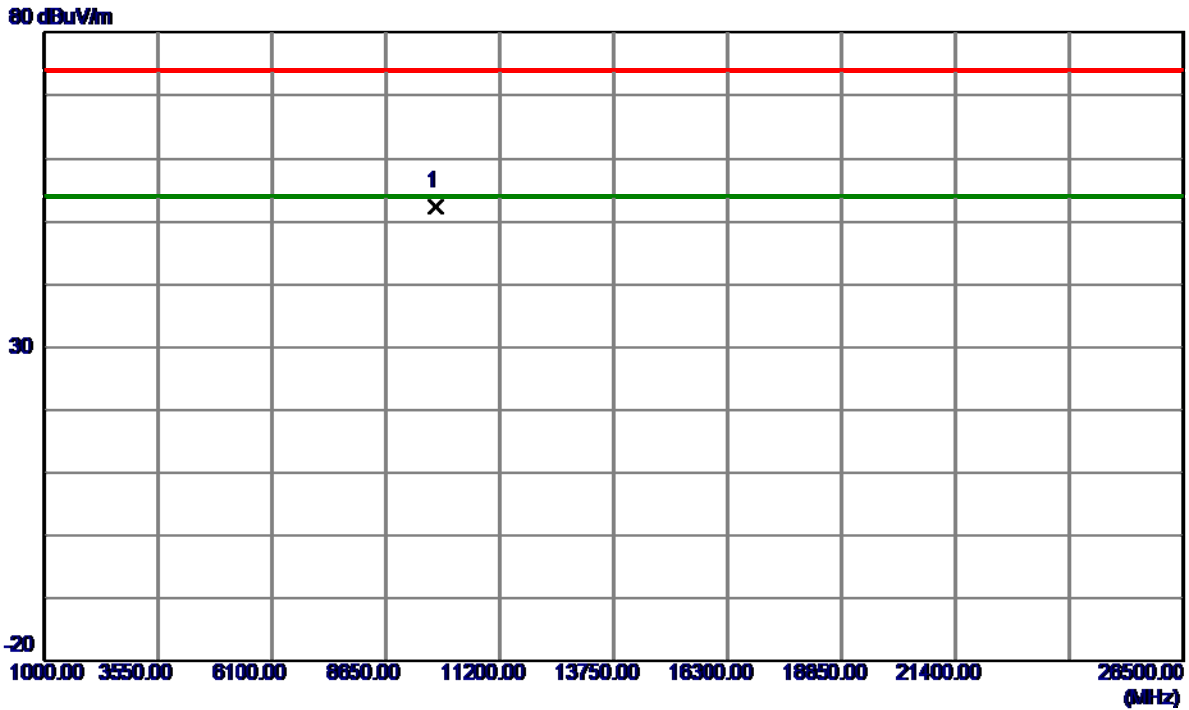

No.	Freq. MHz	Reading Level dBuV/m	Correct Factor dB	Measure ment dBuV/m	Limit dBuV/m	Margin dB	Detector	Comment
1 *	9747.9600	51.42	0.99	52.41	74.00	-21.59	Peak	

REMARKS:

- (1) Measurement Value = Reading Level + Correct Factor.
- (2) Margin Level = Measurement Value - Limit Value.

Test Mode: TX G Mode 2462 MHz

Vertical

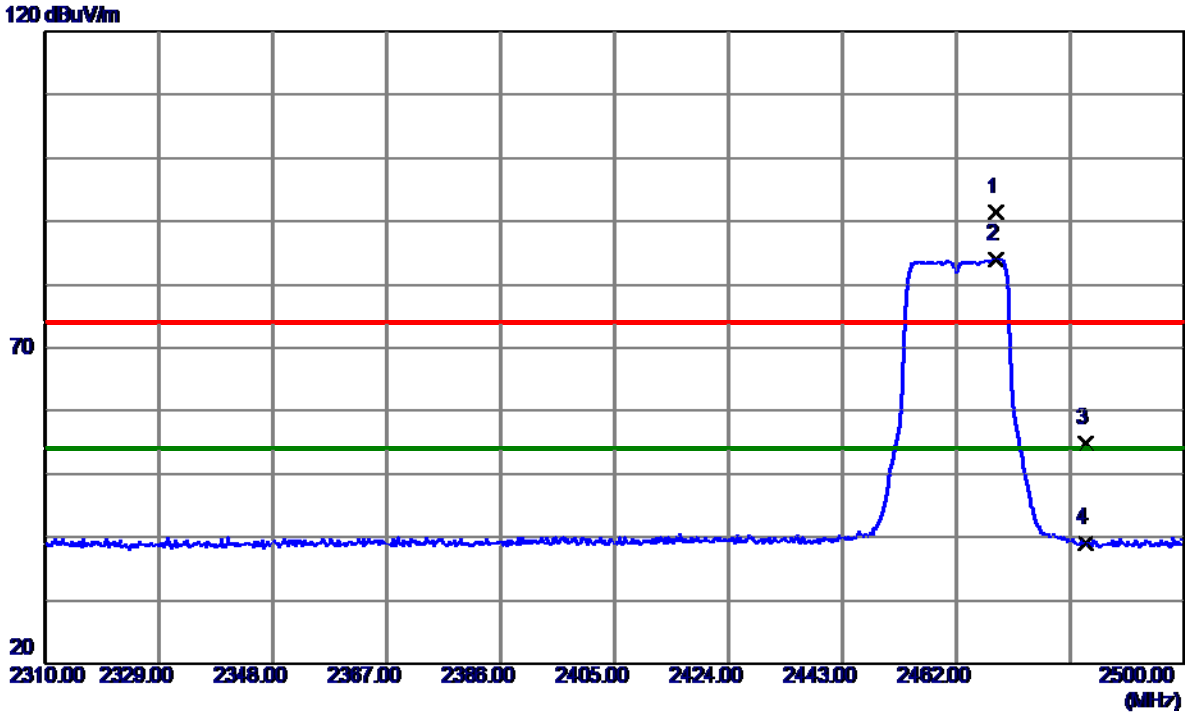

No.	Freq. MHz	Reading Level dBuV/m	Correct Factor dB	Measure ment dBuV/m	Limit dBuV/m	Margin dB	Detector	Comment
1	2468.4600	59.73	31.71	91.44	74.00	17.44	Peak	No limit
2 *	2468.4600	52.33	31.71	84.04	54.00	30.04	AVG	No limit
3	2483.5000	23.16	31.71	54.87	74.00	-19.13	Peak	
4	2483.5000	7.35	31.71	39.06	54.00	-14.94	AVG	

REMARKS:

- (1) Measurement Value = Reading Level + Correct Factor.
- (2) Margin Level = Measurement Value - Limit Value.

Test Mode: TX G Mode 2462 MHz

### Vertical

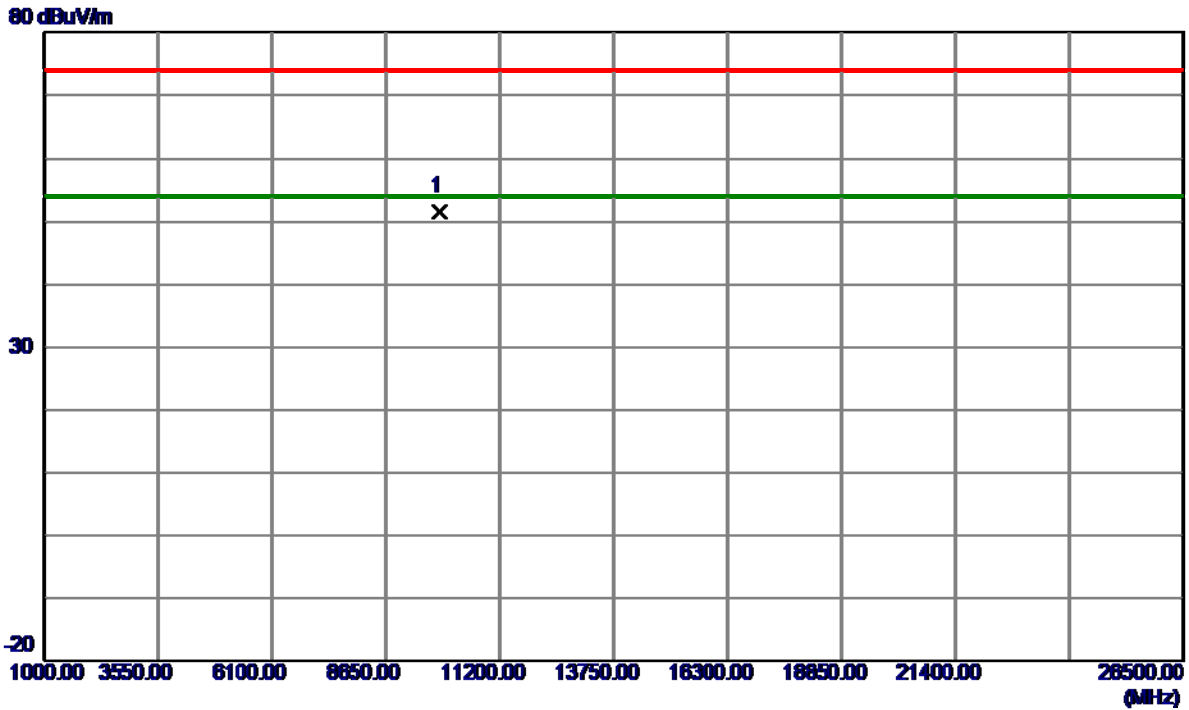

No.	Freq. MHz	Reading Level dBuV/m	Correct Factor dB	Measure ment dBuV/m	Limit dBuV/m	Margin dB	Detector	Comment
1 *	9848.0800	50.47	1.17	51.64	74.00	-22.36	Peak	

**REMARKS:**

- (1) Measurement Value = Reading Level + Correct Factor.
- (2) Margin Level = Measurement Value - Limit Value.

Test Mode: TX G Mode 2462 MHz

### Horizontal

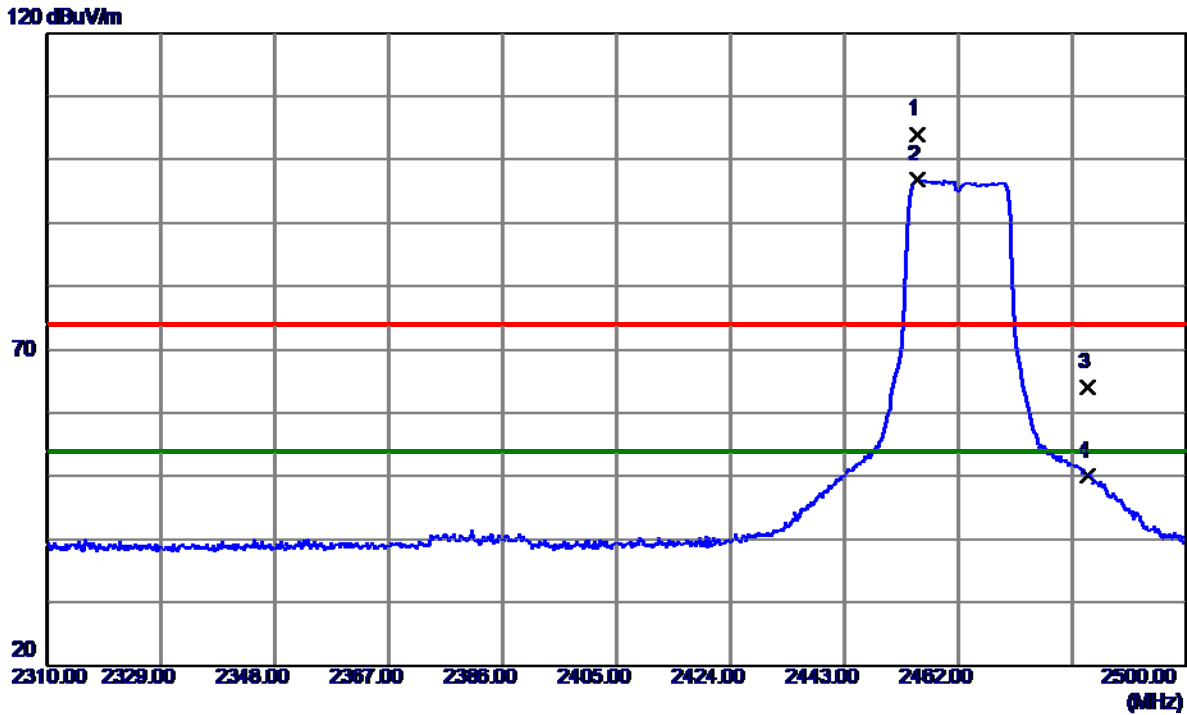

No.	Freq. MHz	Reading Level dBuV/m	Correct Factor dB	Measure ment dBuV/m	Limit dBuV/m	Margin dB	Detector	Comment
1	2454.9700	72.26	31.71	103.97	74.00	29.97	Peak	No limit
2 *	2454.9700	65.03	31.71	96.74	54.00	42.74	AVG	No limit
3	2483.5000	32.37	31.71	64.08	74.00	-9.92	Peak	
4	2483.5000	18.33	31.71	50.04	54.00	-3.96	AVG	

**REMARKS:**

- (1) Measurement Value = Reading Level + Correct Factor.
- (2) Margin Level = Measurement Value - Limit Value.

Test Mode: TX G Mode 2462 MHz

### Horizontal

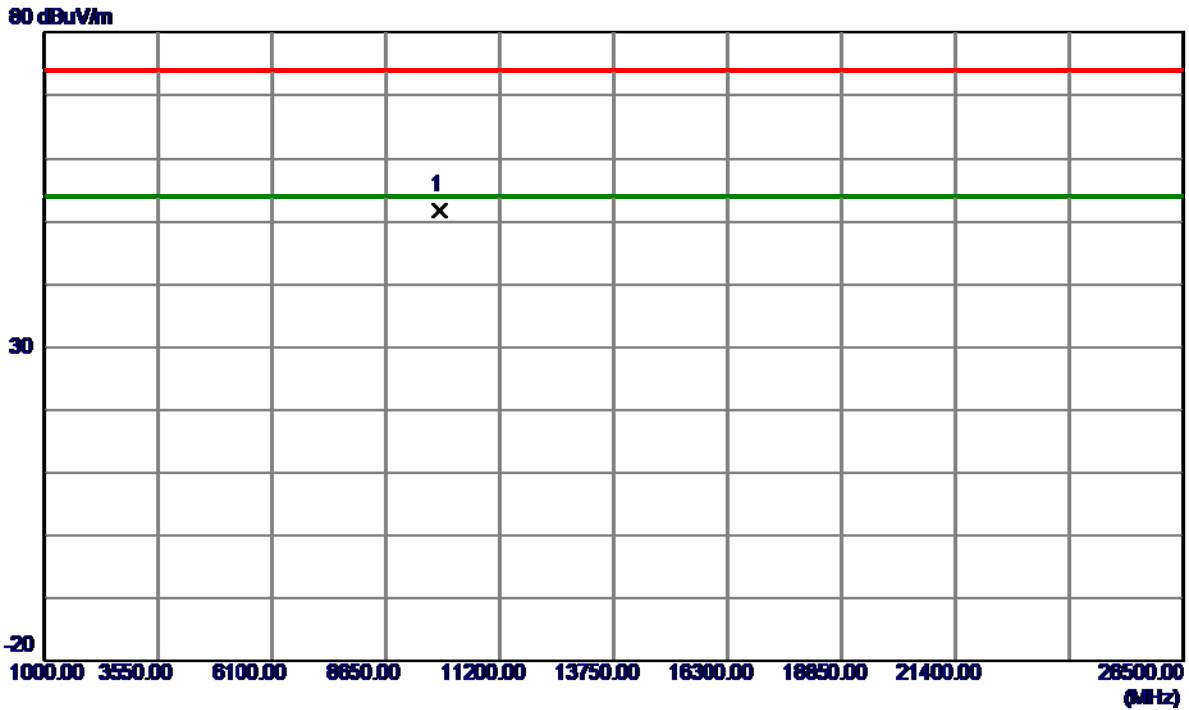

No.	Freq. MHz	Reading Level dBuV/m	Correct Factor dB	Measure ment dBuV/m	Limit dBuV/m	Margin dB	Detector	Comment
1 *	9848.1000	50.61	1.17	51.78	74.00	-22.22	Peak	

**REMARKS:**

- (1) Measurement Value = Reading Level + Correct Factor.
- (2) Margin Level = Measurement Value - Limit Value.

Test Mode: TX N-20M Mode 2412 MHz

Vertical

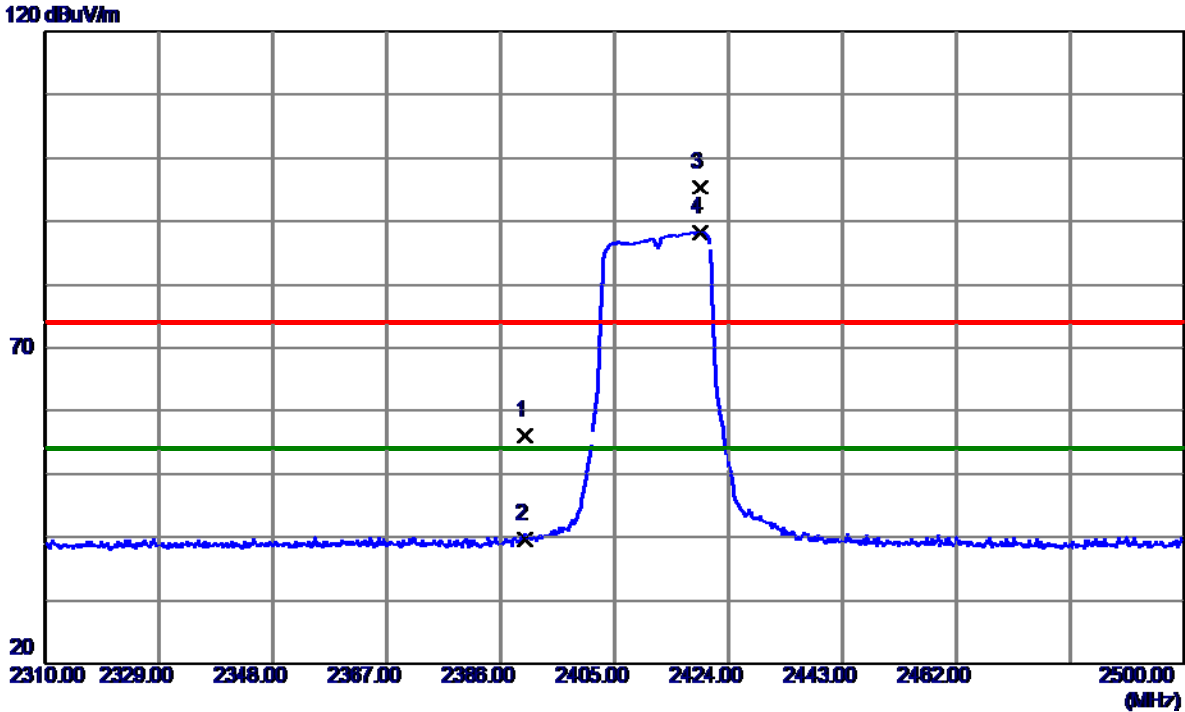

No.	Freq. MHz	Reading Level dBuV/m	Correct Factor dB	Measure ment dBuV/m	Limit dBuV/m	Margin dB	Detector	Comment
1	2390.0000	24.34	31.74	56.08	74.00	-17.92	Peak	
2	2390.0000	7.84	31.74	39.58	54.00	-14.42	AVG	
3	2419.1550	63.75	31.72	95.47	74.00	21.47	Peak	No limit
4 *	2419.1550	56.55	31.72	88.27	54.00	34.27	AVG	No limit

REMARKS:

- (1) Measurement Value = Reading Level + Correct Factor.
- (2) Margin Level = Measurement Value - Limit Value.

Test Mode: TX N-20M Mode 2412 MHz

### Vertical

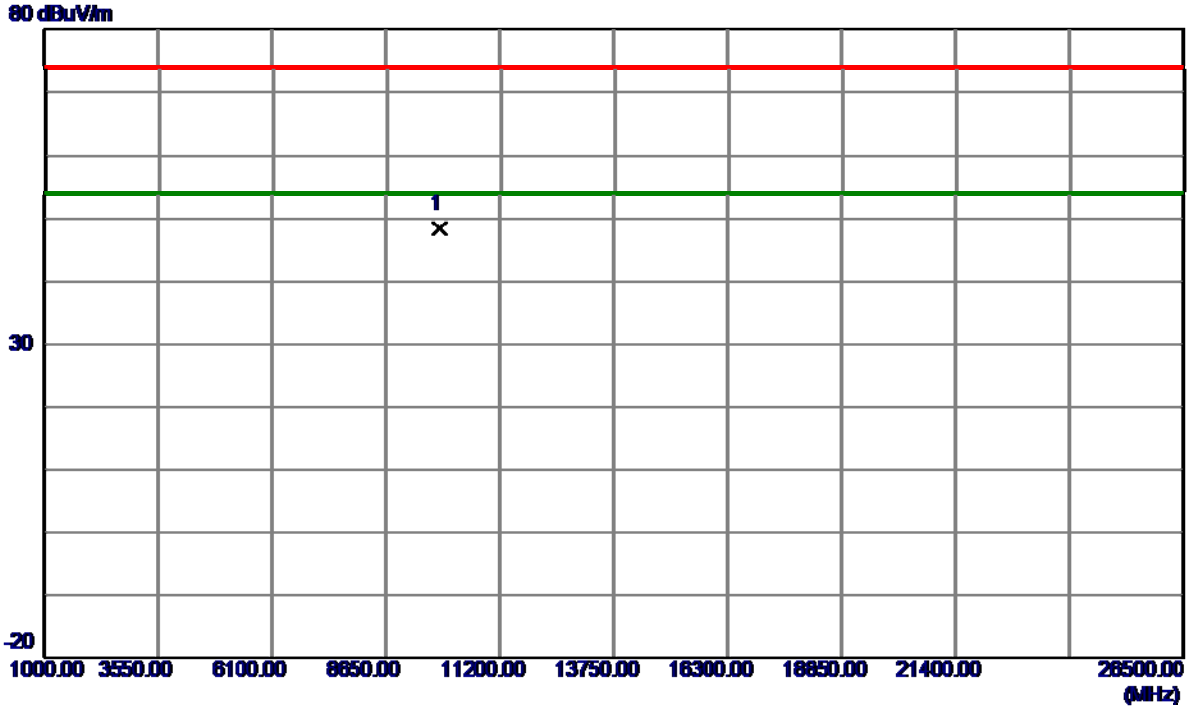

No.	Freq. MHz	Reading Level dBuV/m	Correct Factor dB	Measure ment dBuV/m	Limit dBuV/m	Margin dB	Detector	Comment
1 *	9848.9269	47.30	1.17	48.47	74.00	-25.53	Peak	

**REMARKS:**

- (1) Measurement Value = Reading Level + Correct Factor.
- (2) Margin Level = Measurement Value - Limit Value.

Test Mode: TX N-20M Mode 2412 MHz

### Horizontal

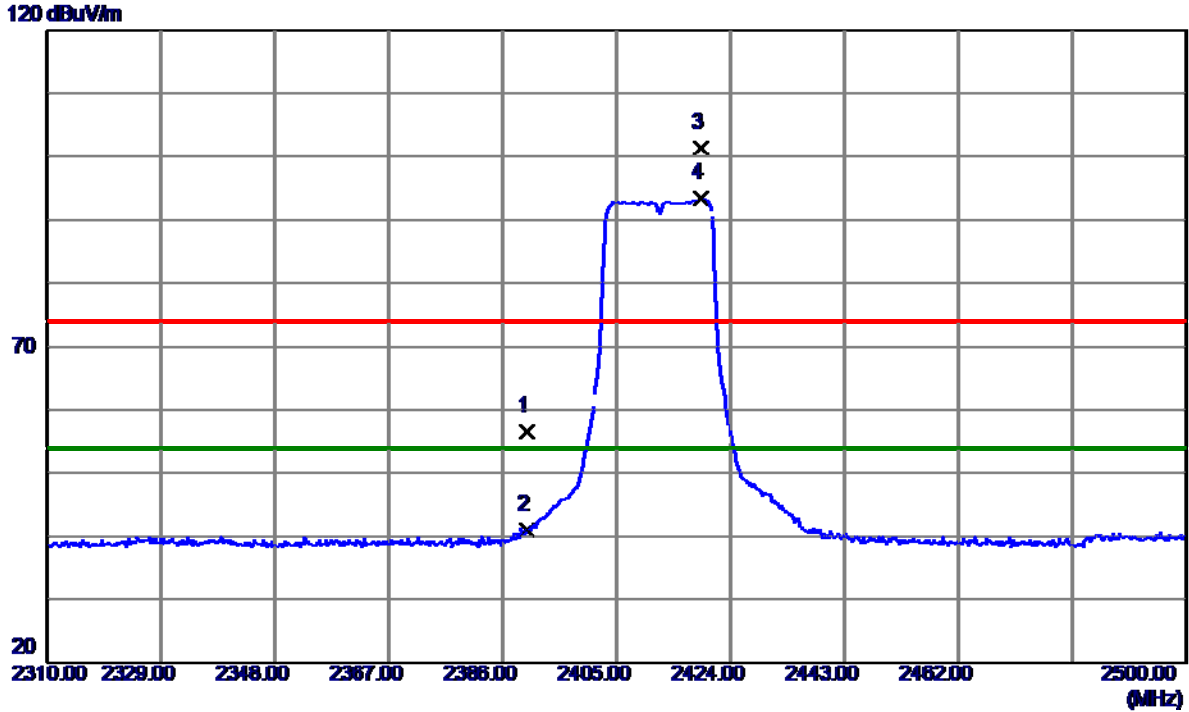

No.	Freq. MHz	Reading Level dBuV/m	Correct Factor dB	Measure ment dBuV/m	Limit dBuV/m	Margin dB	Detector	Comment
1	2390.0000	24.85	31.74	56.59	74.00	-17.41	Peak	
2	2390.0000	9.23	31.74	40.97	54.00	-13.03	AVG	
3	2418.9650	69.59	31.72	101.31	74.00	27.31	Peak	No limit
4 *	2418.9650	61.64	31.72	93.36	54.00	39.36	AVG	No limit

**REMARKS:**

(1) Measurement Value = Reading Level + Correct Factor.

(2) Margin Level = Measurement Value - Limit Value.



Test Mode: TX N-20M Mode 2412 MHz

### Horizontal

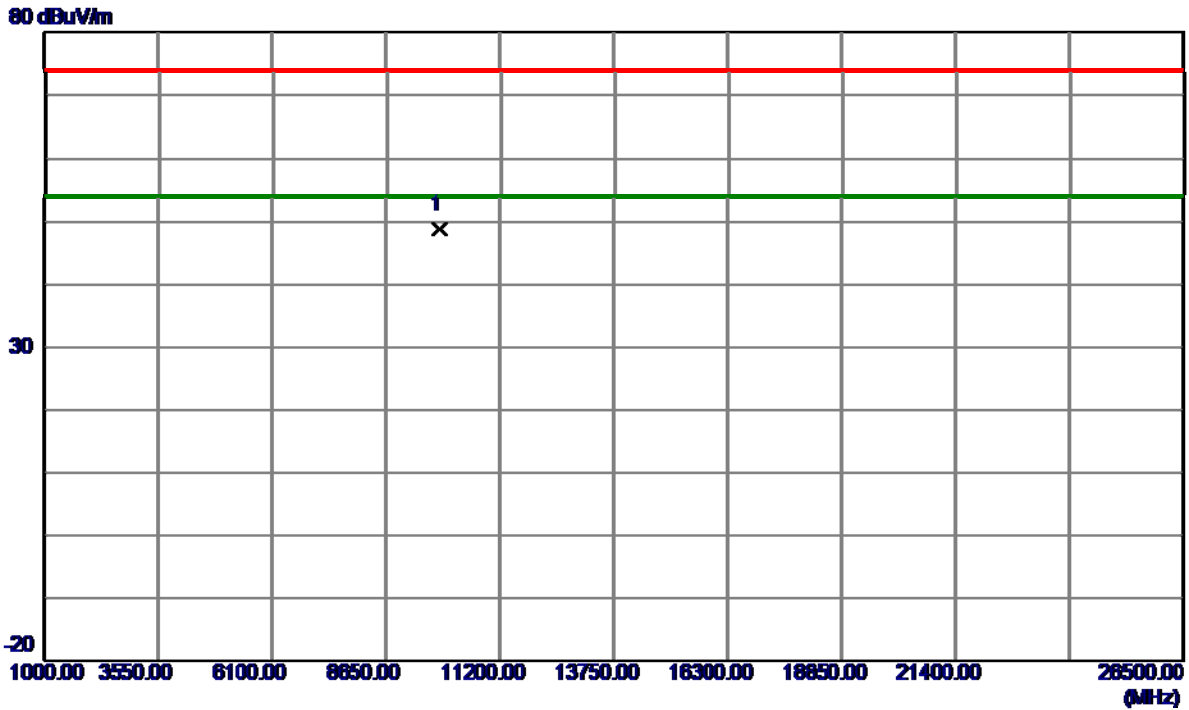

No.	Freq. MHz	Reading Level dBuV/m	Correct Factor dB	Measure ment dBuV/m	Limit dBuV/m	Margin dB	Detector	Comment
1 *	9848.8550	47.71	1.17	48.88	74.00	-25.12	Peak	

REMARKS:

- (1) Measurement Value = Reading Level + Correct Factor.
- (2) Margin Level = Measurement Value - Limit Value.

Test Mode: TX N-20M Mode 2437 MHz

Vertical

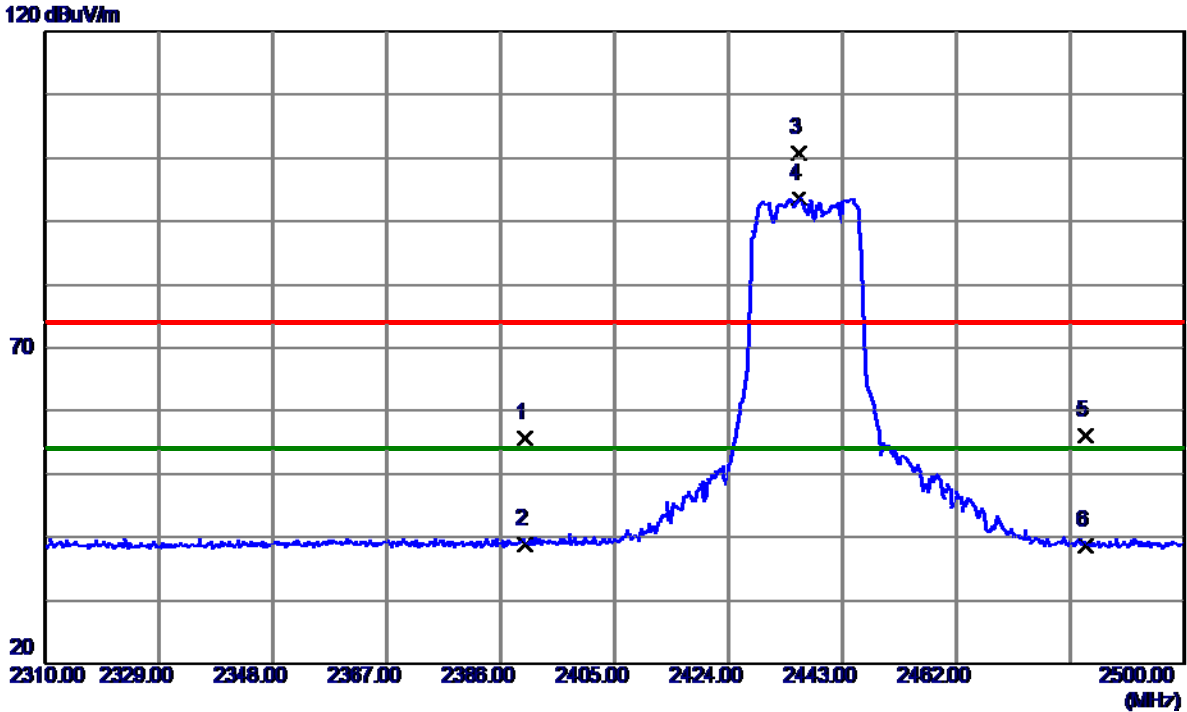

No.	Freq. MHz	Reading Level dBuV/m	Correct Factor dB	Measurement dBuV/m	Limit dBuV/m	Margin dB	Detector	Comment
1	2390.0000	23.91	31.74	55.65	74.00	-18.35	Peak	
2	2390.0000	7.02	31.74	38.76	54.00	-15.24	AVG	
3	2435.6850	69.08	31.72	100.80	74.00	26.80	Peak	No limit
4 *	2435.6850	61.86	31.72	93.58	54.00	39.58	AVG	No limit
5	2483.5000	24.30	31.71	56.01	74.00	-17.99	Peak	
6	2483.5000	6.91	31.71	38.62	54.00	-15.38	AVG	

REMARKS:

- (1) Measurement Value = Reading Level + Correct Factor.
- (2) Margin Level = Measurement Value - Limit Value.

Test Mode: TX N-20M Mode 2437 MHz

### Vertical

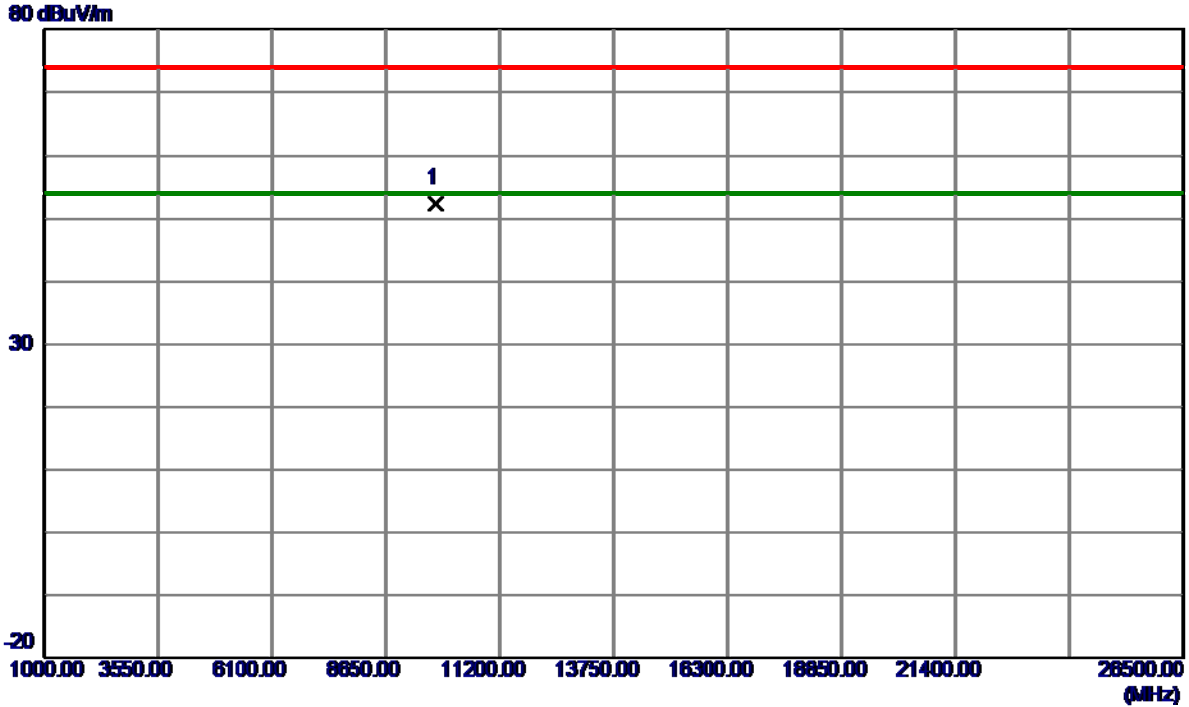

No.	Freq. MHz	Reading Level dBuV/m	Correct Factor dB	Measure ment dBuV/m	Limit dBuV/m	Margin dB	Detector	Comment
1 *	9748.0100	51.46	0.99	52.45	74.00	-21.55	Peak	

**REMARKS:**

- (1) Measurement Value = Reading Level + Correct Factor.
- (2) Margin Level = Measurement Value - Limit Value.

Test Mode: TX N-20M Mode 2437 MHz

### Horizontal

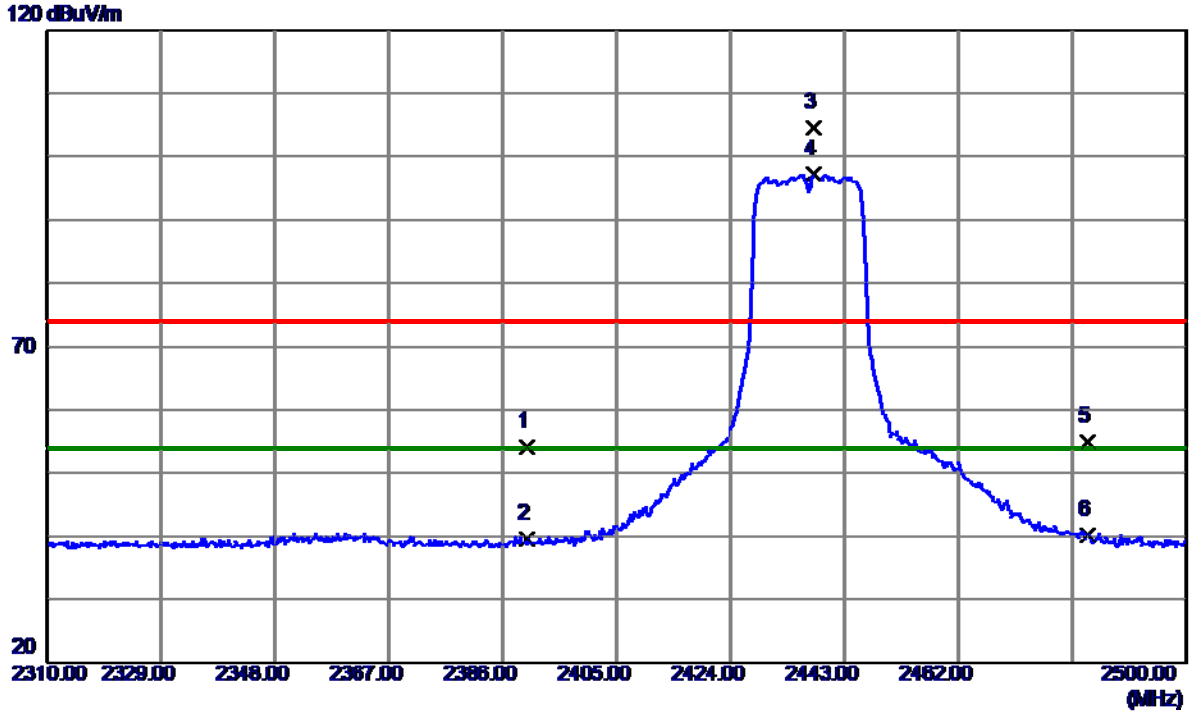

No.	Freq. MHz	Reading Level dBuV/m	Correct Factor dB	Measure ment dBuV/m	Limit dBuV/m	Margin dB	Detector	Comment
1	2390.0000	22.54	31.74	54.28	74.00	-19.72	Peak	
2	2390.0000	7.80	31.74	39.54	54.00	-14.46	AVG	
3	2437.7750	72.88	31.72	104.60	74.00	30.60	Peak	No limit
4 *	2437.7750	65.40	31.72	97.12	54.00	43.12	AVG	No limit
5	2483.5000	23.24	31.71	54.95	74.00	-19.05	Peak	
6	2483.5000	8.56	31.71	40.27	54.00	-13.73	AVG	

**REMARKS:**

- (1) Measurement Value = Reading Level + Correct Factor.
- (2) Margin Level = Measurement Value - Limit Value.

Test Mode: TX N-20M Mode 2437 MHz

### Horizontal

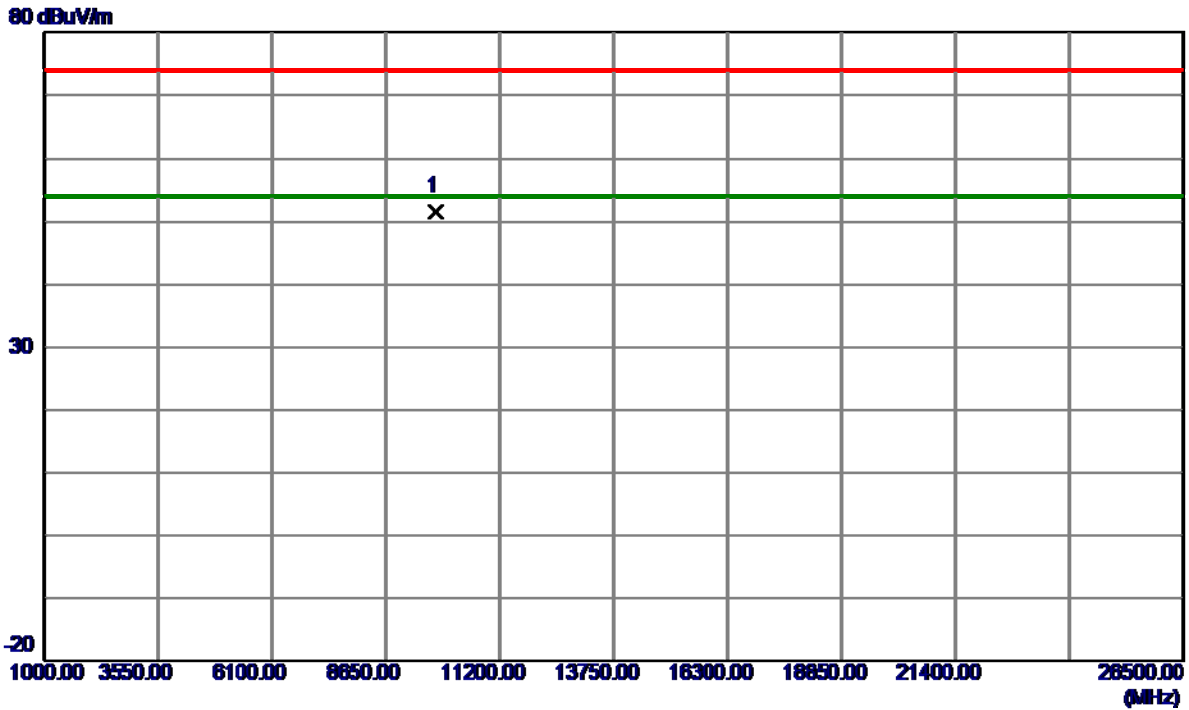

No.	Freq. MHz	Reading Level dBuV/m	Correct Factor dB	Measure ment dBuV/m	Limit dBuV/m	Margin dB	Detector	Comment
1 *	9748.2000	50.56	0.99	51.55	74.00	-22.45	Peak	

**REMARKS:**

- (1) Measurement Value = Reading Level + Correct Factor.
- (2) Margin Level = Measurement Value - Limit Value.

Test Mode: TX N-20M Mode 2462 MHz

Vertical

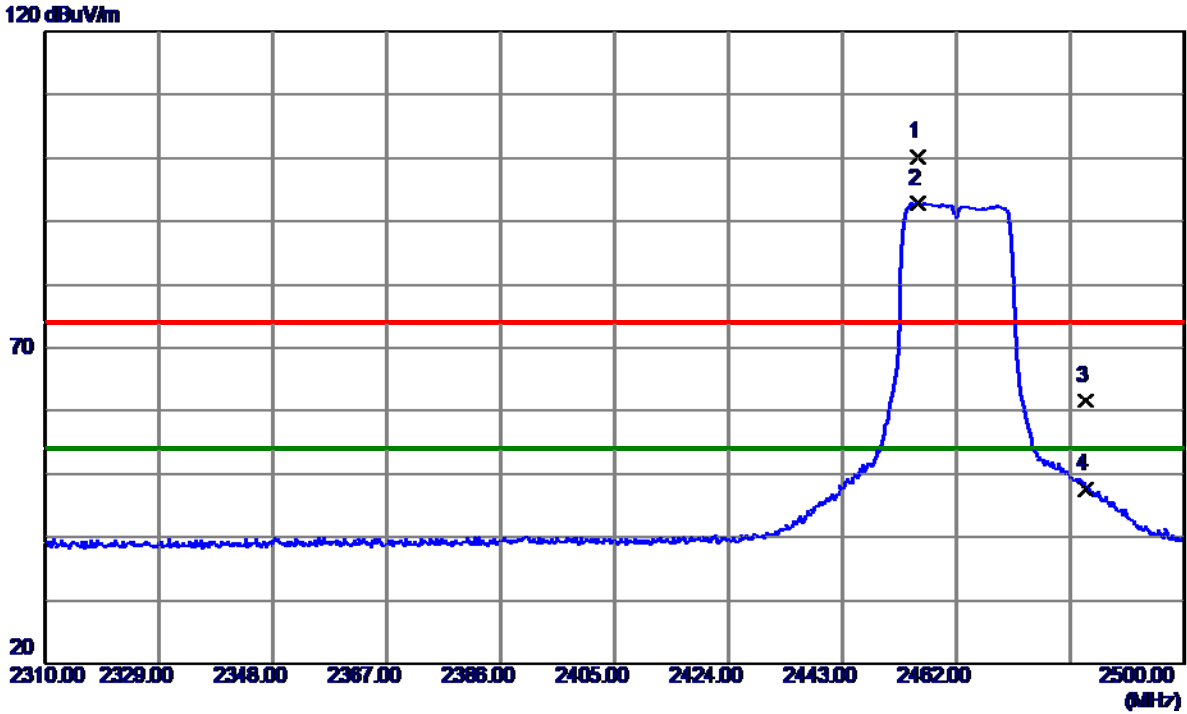

No.	Freq. MHz	Reading Level dBuV/m	Correct Factor dB	Measure ment dBuV/m	Limit dBuV/m	Margin dB	Detector	Comment
1	2455.4450	68.42	31.71	100.13	74.00	26.13	Peak	No limit
2 *	2455.4450	61.10	31.71	92.81	54.00	38.81	AVG	No limit
3	2483.5000	29.82	31.71	61.53	74.00	-12.47	Peak	
4	2483.5000	15.84	31.71	47.55	54.00	-6.45	AVG	

REMARKS:

- (1) Measurement Value = Reading Level + Correct Factor.
- (2) Margin Level = Measurement Value - Limit Value.

Test Mode: TX N-20M Mode 2462 MHz

### Vertical

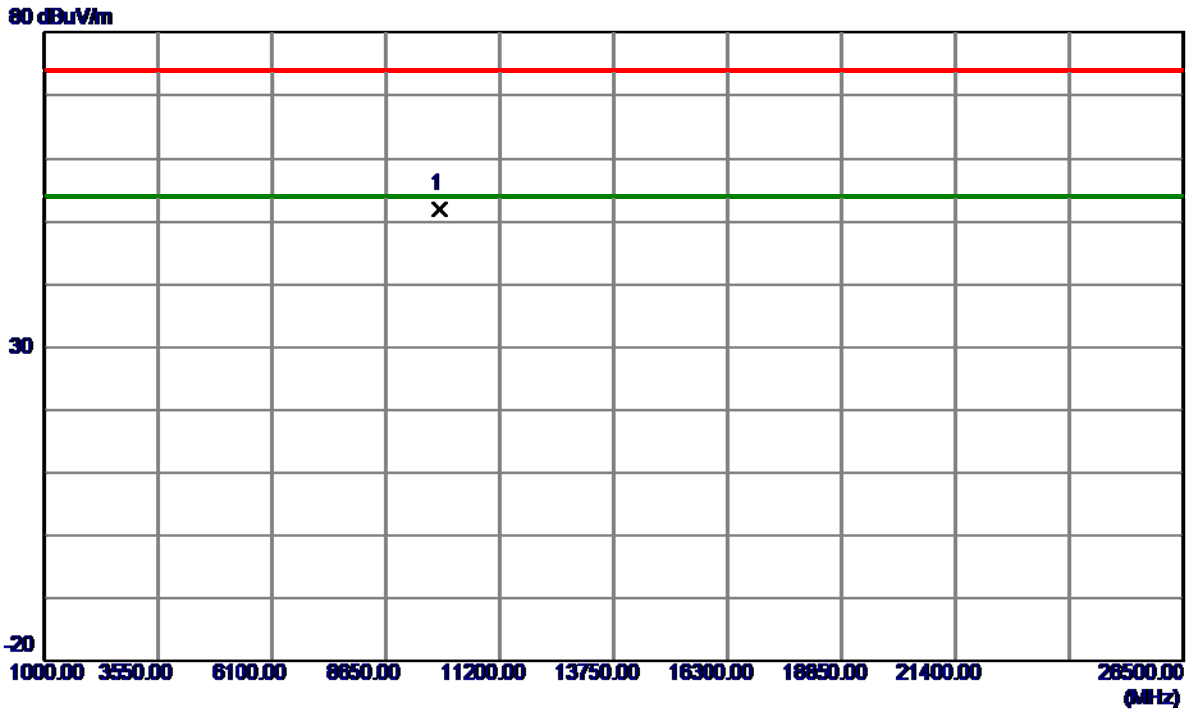

No.	Freq. MHz	Reading Level dBuV/m	Correct Factor dB	Measure ment dBuV/m	Limit dBuV/m	Margin dB	Detector	Comment
1 *	9848.1800	50.88	1.17	52.05	74.00	-21.95	Peak	

**REMARKS:**

- (1) Measurement Value = Reading Level + Correct Factor.
- (2) Margin Level = Measurement Value - Limit Value.

Test Mode: TX N-20M Mode 2462 MHz

### Horizontal

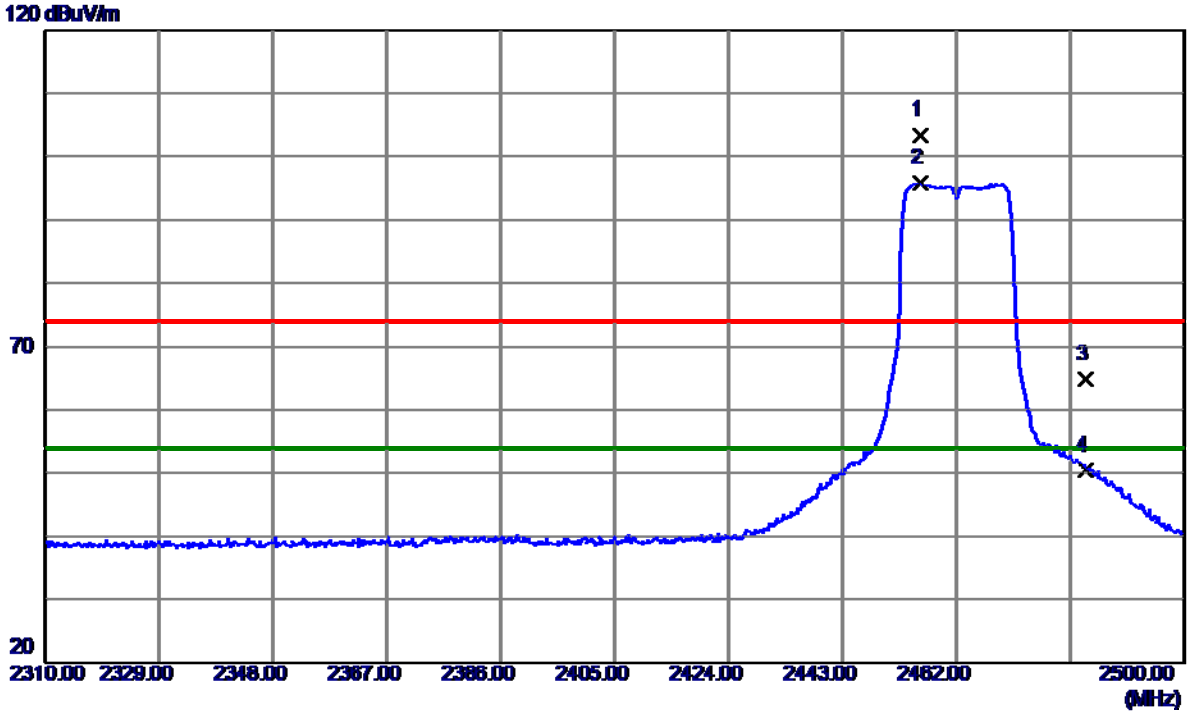

No.	Freq. MHz	Reading Level dBuV/m	Correct Factor dB	Measure ment dBuV/m	Limit dBuV/m	Margin dB	Detector	Comment
1	2455.8250	71.64	31.71	103.35	74.00	29.35	Peak	No limit
2 *	2455.8250	64.11	31.71	95.82	54.00	41.82	AVG	No limit
3	2483.5000	33.06	31.71	64.77	74.00	-9.23	Peak	
4	2483.5000	18.64	31.71	50.35	54.00	-3.65	AVG	

**REMARKS:**

(1) Measurement Value = Reading Level + Correct Factor.

(2) Margin Level = Measurement Value - Limit Value.



Test Mode: TX N-20M Mode 2462 MHz

### Horizontal

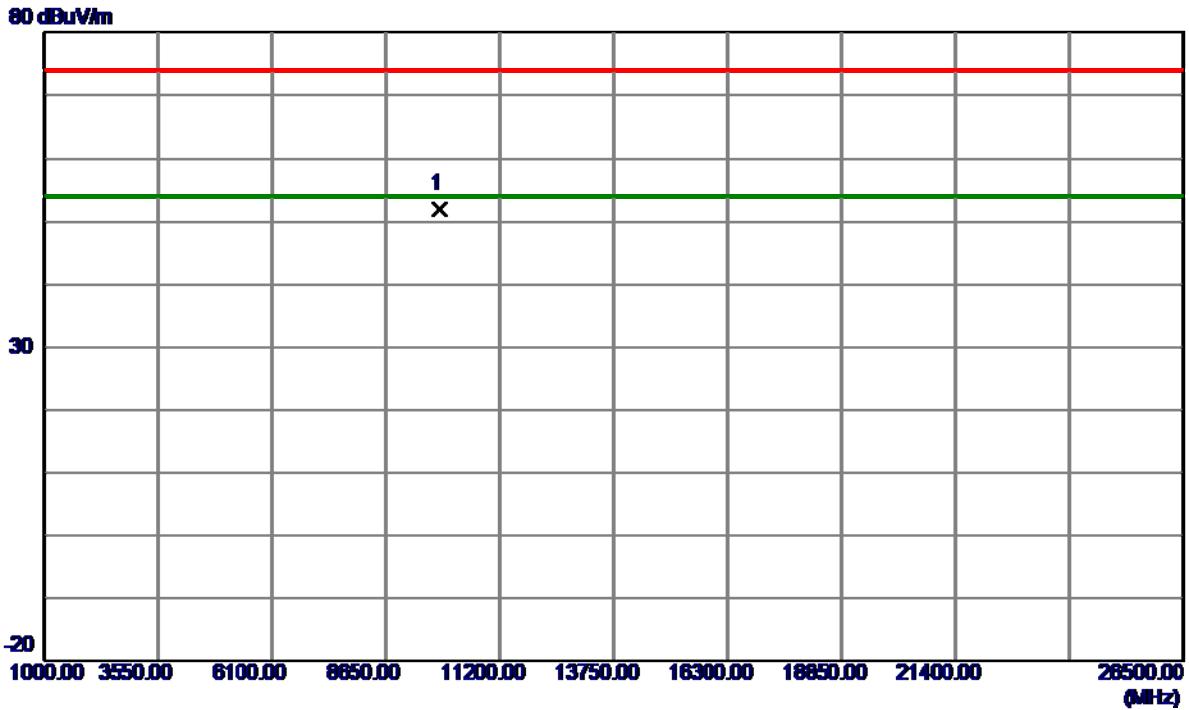

No.	Freq. MHz	Reading Level dBuV/m	Correct Factor dB	Measure ment dBuV/m	Limit dBuV/m	Margin dB	Detector	Comment
1 *	9848.2720	50.84	1.17	52.01	74.00	-21.99	Peak	

REMARKS:

- (1) Measurement Value = Reading Level + Correct Factor.
- (2) Margin Level = Measurement Value - Limit Value.

Test Mode: TX N-40M Mode 2422MHz

Vertical

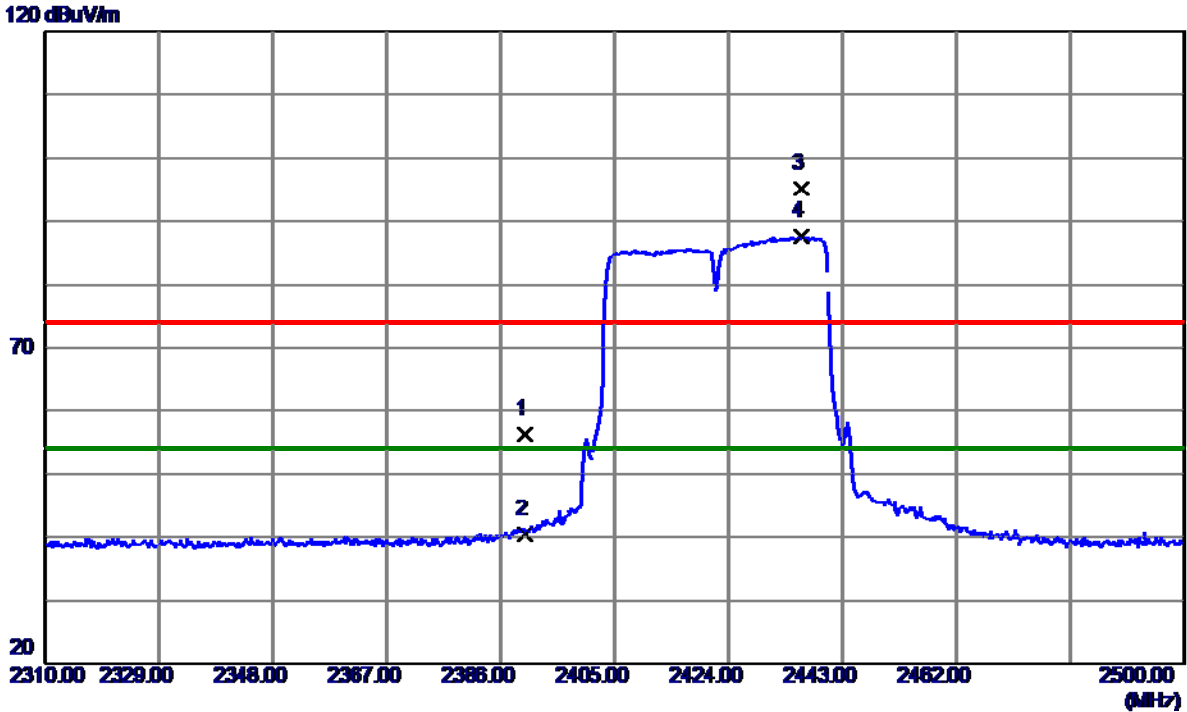

No.	Freq. MHz	Reading Level dBuV/m	Correct Factor dB	Measure ment dBuV/m	Limit dBuV/m	Margin dB	Detector	Comment
1	2390.0000	24.40	31.74	56.14	74.00	-17.86	Peak	
2	2390.0000	8.72	31.74	40.46	54.00	-13.54	AVG	
3	2436.0650	63.51	31.72	95.23	74.00	21.23	Peak	No limit
4 *	2436.0650	55.79	31.72	87.51	54.00	33.51	AVG	No limit

REMARKS:

- (1) Measurement Value = Reading Level + Correct Factor.
- (2) Margin Level = Measurement Value - Limit Value.

Test Mode: TX N-40M Mode 2422MHz

### Vertical

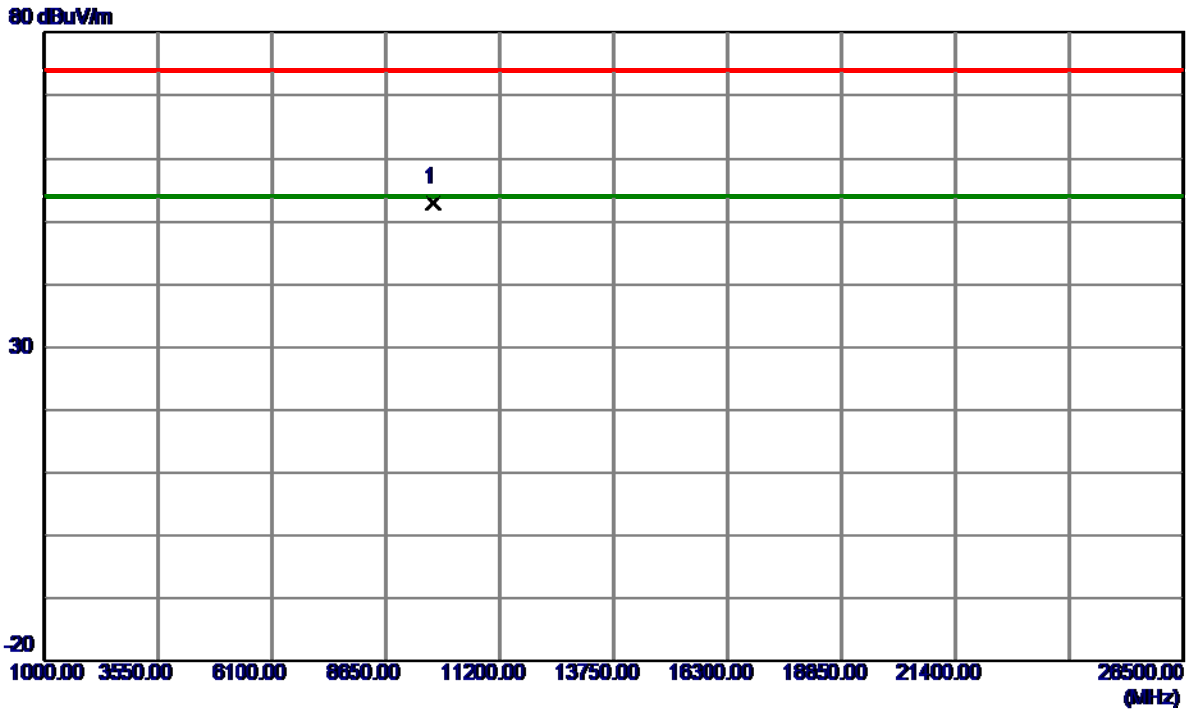

No.	Freq. MHz	Reading Level dBuV/m	Correct Factor dB	Measure ment dBuV/m	Limit dBuV/m	Margin dB	Detector	Comment
1 *	9687.8650	52.26	0.75	53.01	74.00	-20.99	Peak	

**REMARKS:**

- (1) Measurement Value = Reading Level + Correct Factor.
- (2) Margin Level = Measurement Value - Limit Value.

Test Mode: TX N-40M Mode 2422MHz

### Horizontal

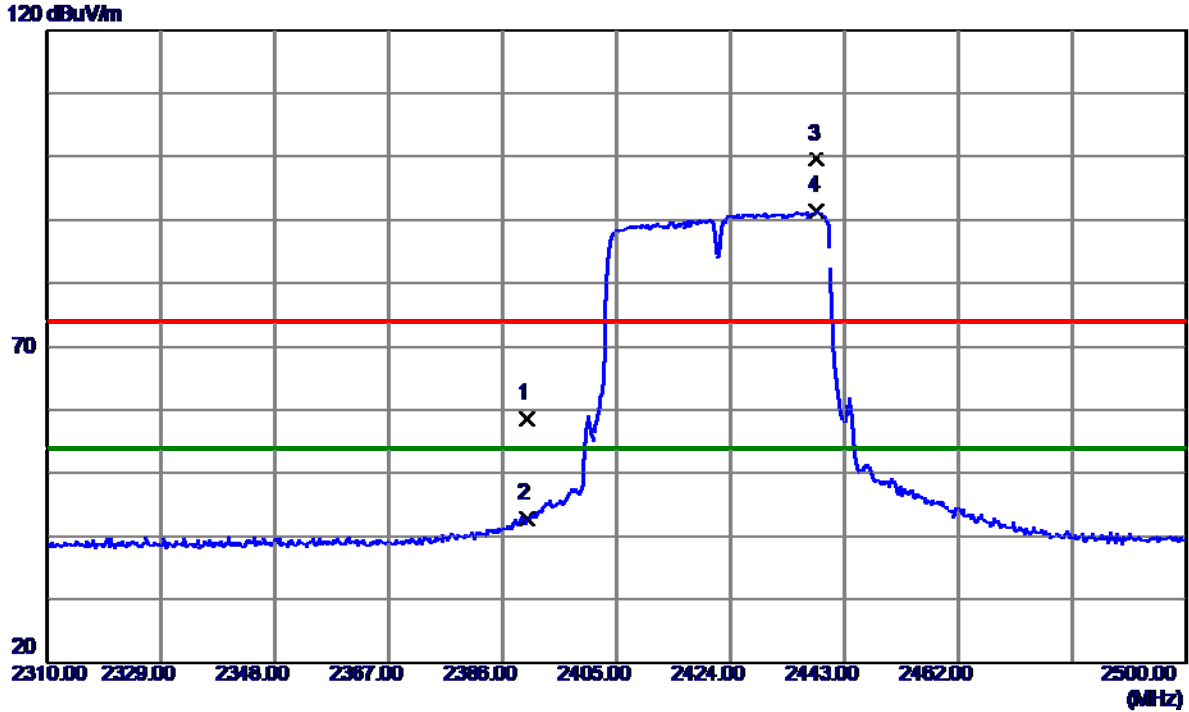

No.	Freq. MHz	Reading Level dBuV/m	Correct Factor dB	Measure ment dBuV/m	Limit dBuV/m	Margin dB	Detector	Comment
1	2390.0000	26.80	31.74	58.54	74.00	-15.46	Peak	
2	2390.0000	11.07	31.74	42.81	54.00	-11.19	AVG	
3	2438.2500	67.88	31.72	99.60	74.00	25.60	Peak	No limit
4 *	2438.2500	59.59	31.72	91.31	54.00	37.31	AVG	No limit

**REMARKS:**

(1) Measurement Value = Reading Level + Correct Factor.

(2) Margin Level = Measurement Value - Limit Value.

Test Mode: TX N-40M Mode 2422MHz

### Horizontal

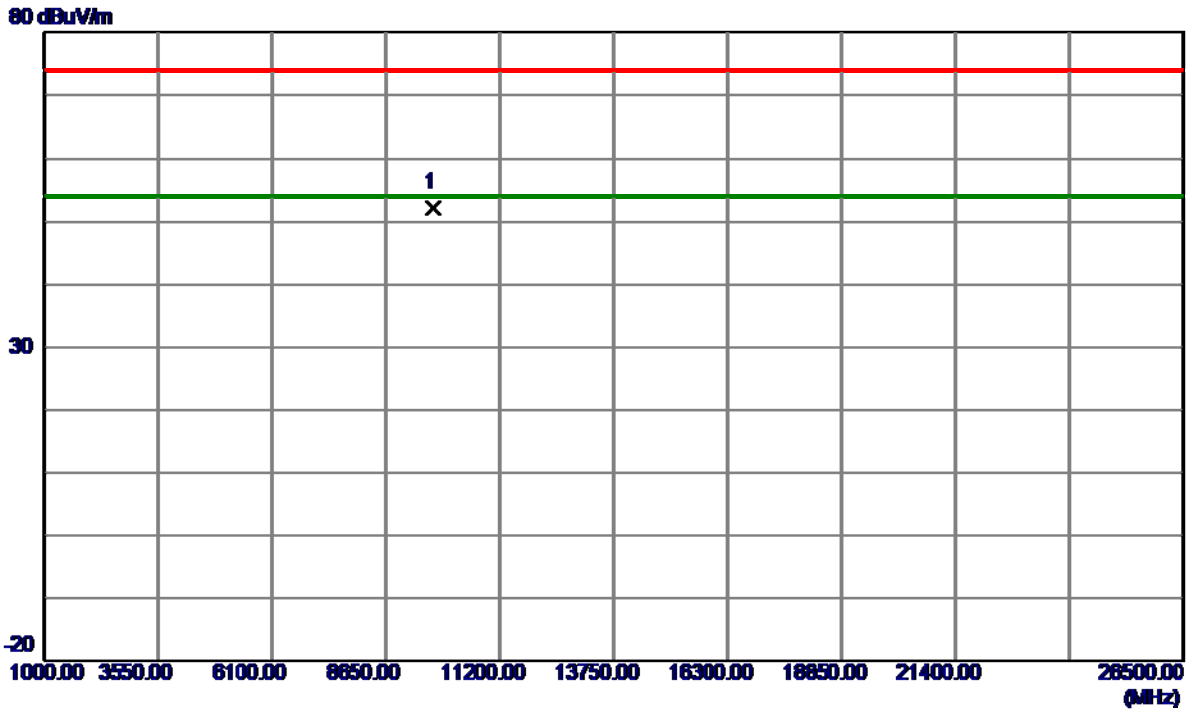

No.	Freq. MHz	Reading Level dBuV/m	Correct Factor dB	Measure ment dBuV/m	Limit dBuV/m	Margin dB	Detector	Comment
1 *	9688.1849	51.51	0.75	52.26	74.00	-21.74	Peak	

REMARKS:

- (1) Measurement Value = Reading Level + Correct Factor.
- (2) Margin Level = Measurement Value - Limit Value.

Test Mode: TX N-40M Mode 2437 MHz

Vertical

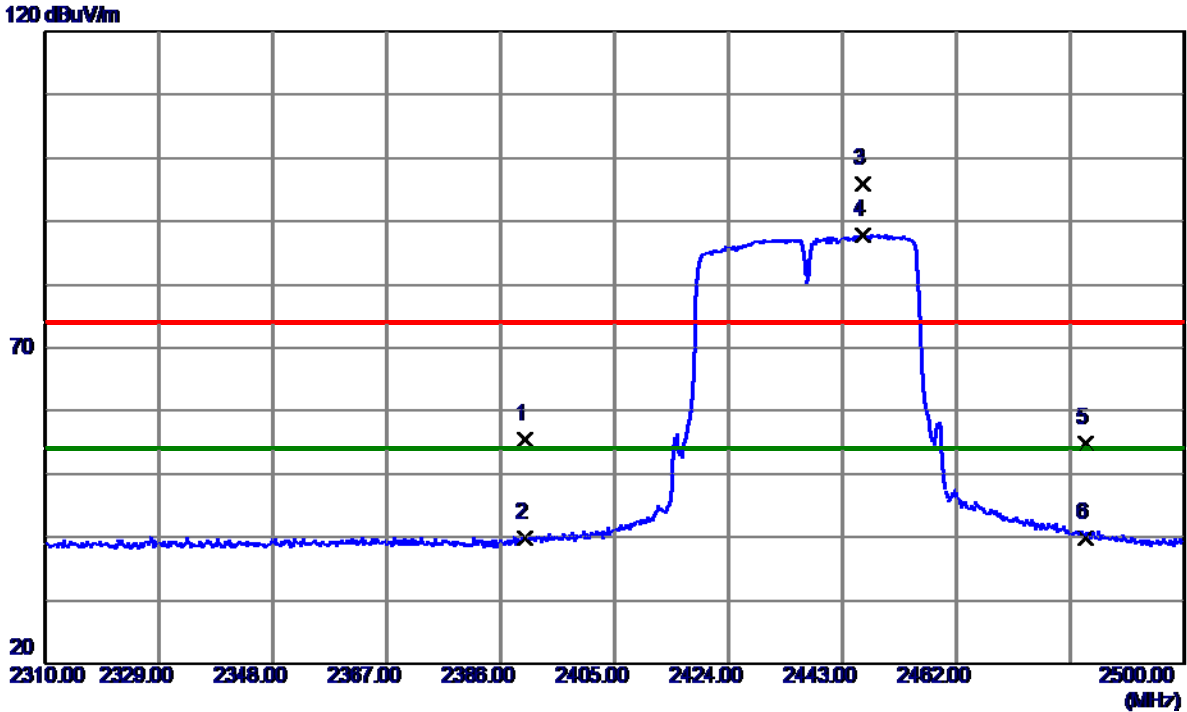

No.	Freq. MHz	Reading Level dBuV/m	Correct Factor dB	Measure ment dBuV/m	Limit dBuV/m	Margin dB	Detector	Comment
1	2390.0000	23.74	31.74	55.48	74.00	-18.52	Peak	
2	2390.0000	8.11	31.74	39.85	54.00	-14.15	AVG	
3	2446.4200	64.27	31.72	95.99	74.00	21.99	Peak	No limit
4 *	2446.4200	56.16	31.72	87.88	54.00	33.88	AVG	No limit
5	2483.5000	23.15	31.71	54.86	74.00	-19.14	Peak	
6	2483.5000	8.16	31.71	39.87	54.00	-14.13	AVG	

REMARKS:

- (1) Measurement Value = Reading Level + Correct Factor.
- (2) Margin Level = Measurement Value - Limit Value.

Test Mode: TX N-40M Mode 2437 MHz

### Vertical

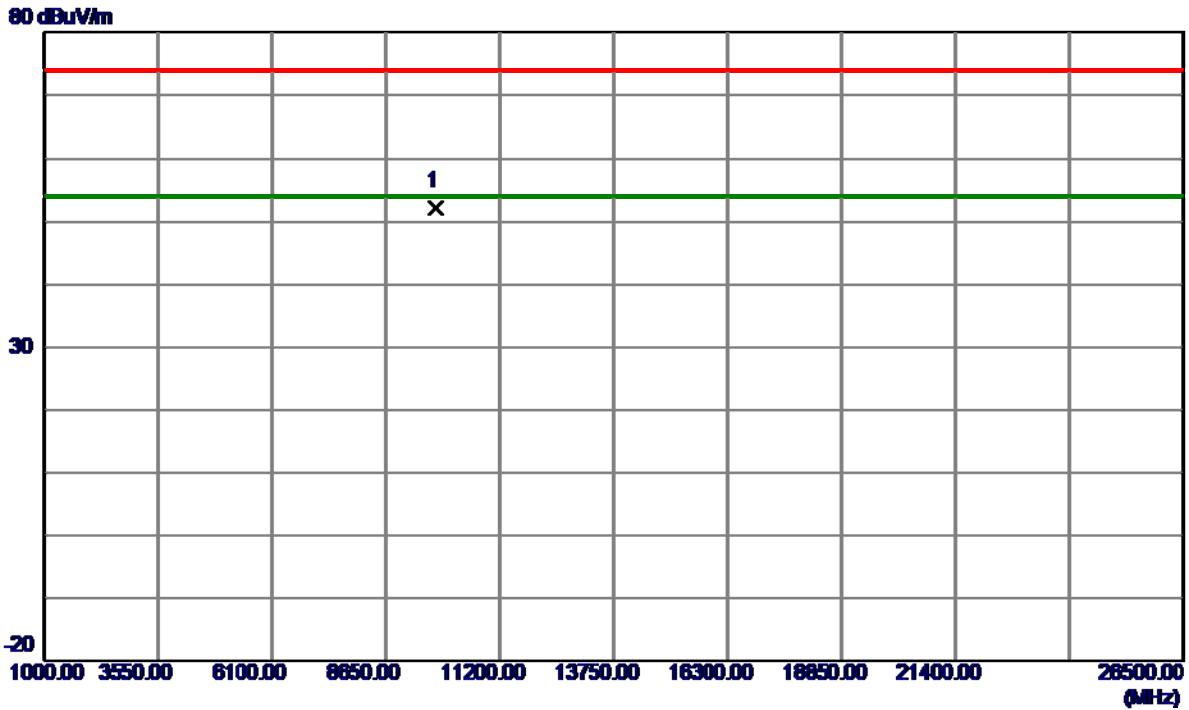

No.	Freq. MHz	Reading Level dBuV/m	Correct Factor dB	Measure ment dBuV/m	Limit dBuV/m	Margin dB	Detector	Comment
1 *	9747.9050	51.31	0.99	52.30	74.00	-21.70	Peak	

**REMARKS:**

- (1) Measurement Value = Reading Level + Correct Factor.
- (2) Margin Level = Measurement Value - Limit Value.

Test Mode: TX N-40M Mode 2437 MHz

### Horizontal

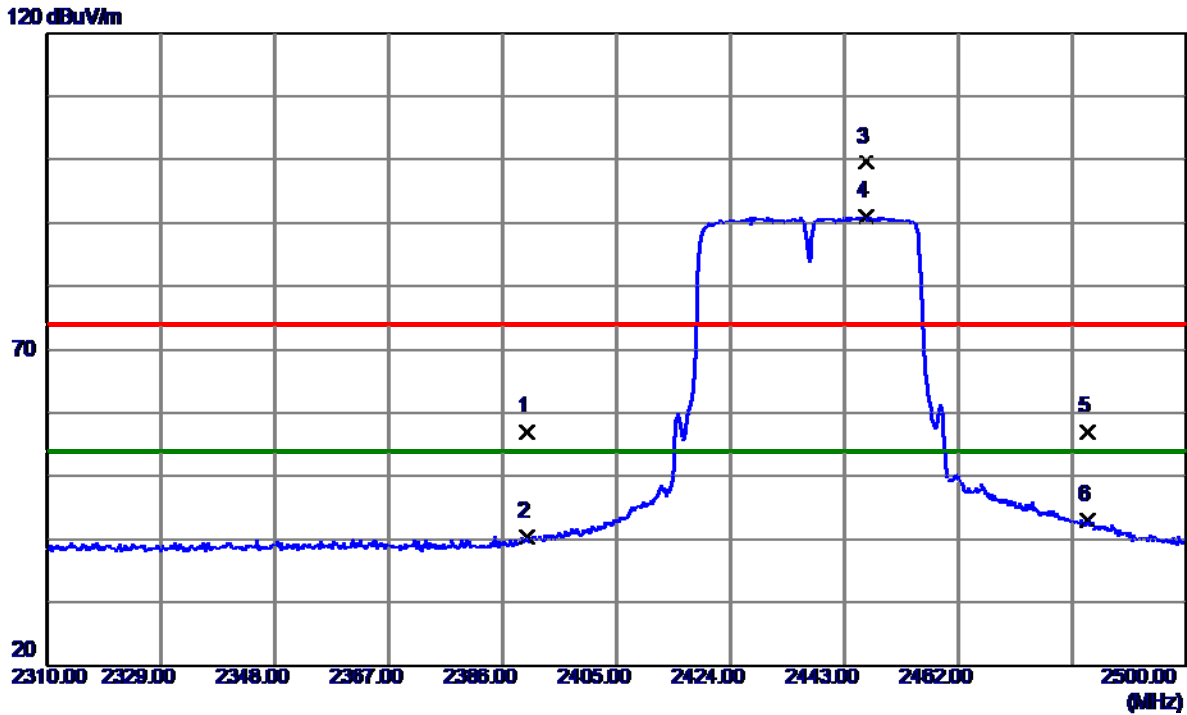

No.	Freq. MHz	Reading Level dBuV/m	Correct Factor dB	Measure ment dBuV/m	Limit dBuV/m	Margin dB	Detector	Comment
1	2390.0000	25.24	31.74	56.98	74.00	-17.02	Peak	
2	2390.0000	8.72	31.74	40.46	54.00	-13.54	AVG	
3	2446.5149	67.96	31.72	99.68	74.00	25.68	Peak	No limit
4 *	2446.5149	59.23	31.72	90.95	54.00	36.95	AVG	No limit
5	2483.5000	25.25	31.71	56.96	74.00	-17.04	Peak	
6	2483.5000	11.21	31.71	42.92	54.00	-11.08	AVG	

**REMARKS:**

- (1) Measurement Value = Reading Level + Correct Factor.
- (2) Margin Level = Measurement Value - Limit Value.



Test Mode: TX N-40M Mode 2437 MHz

### Horizontal

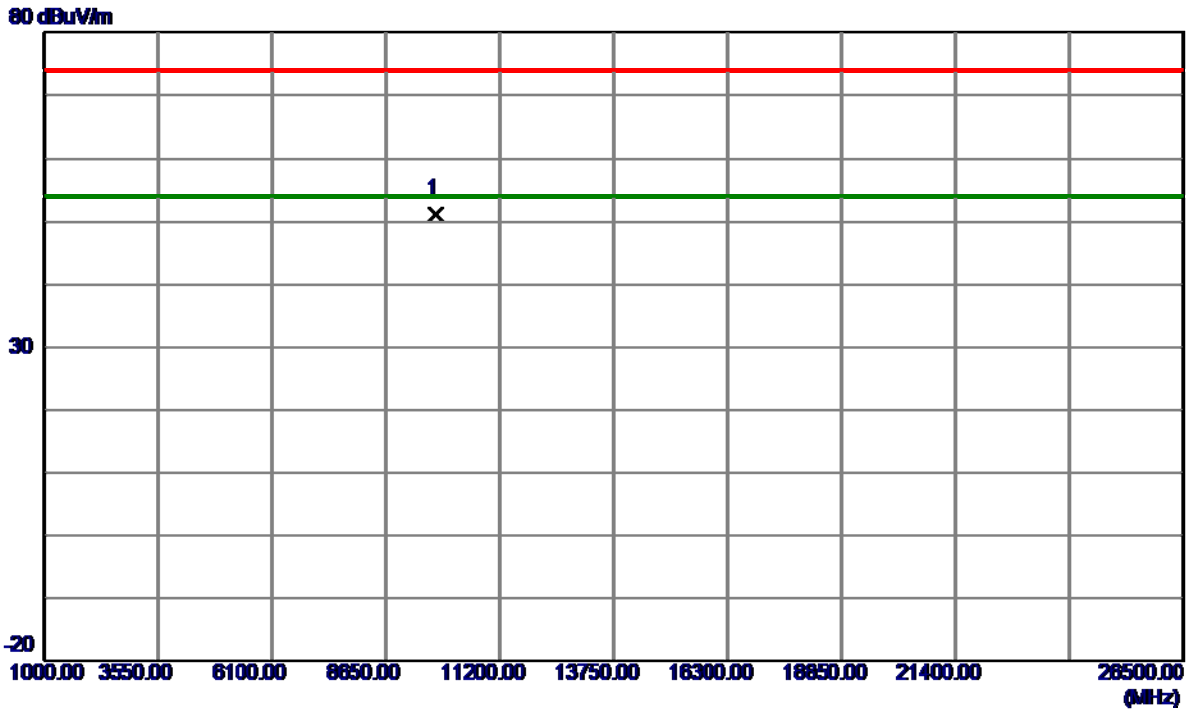

No.	Freq. MHz	Reading Level dBuV/m	Correct Factor dB	Measure ment dBuV/m	Limit dBuV/m	Margin dB	Detector	Comment
1 *	9748.4029	50.30	0.99	51.29	74.00	-22.71	Peak	

**REMARKS:**

- (1) Measurement Value = Reading Level + Correct Factor.
- (2) Margin Level = Measurement Value - Limit Value.

Test Mode: TX N-40M Mode 2452 MHz

Vertical

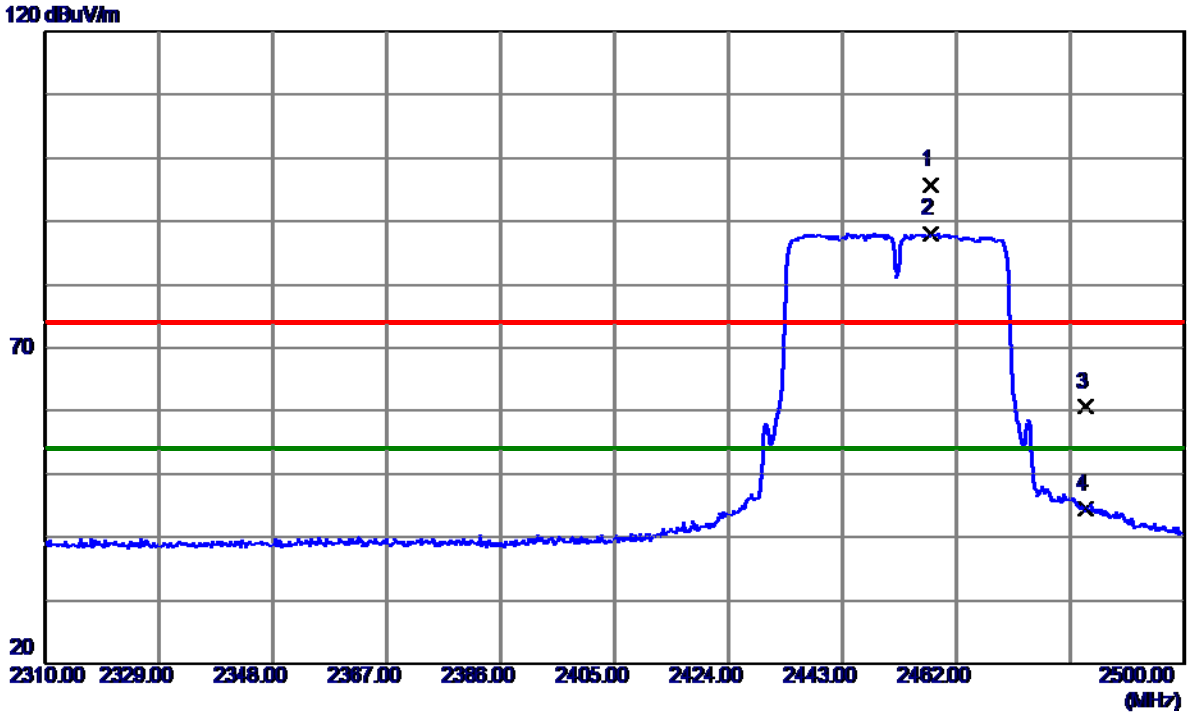

No.	Freq. MHz	Reading Level dBuV/m	Correct Factor dB	Measure ment dBuV/m	Limit dBuV/m	Margin dB	Detector	Comment
1	2457.6299	64.06	31.71	95.77	74.00	21.77	Peak	No limit
2 *	2457.6299	56.31	31.71	88.02	54.00	34.02	AVG	No limit
3	2483.5000	28.88	31.71	60.59	74.00	-13.41	Peak	
4	2483.5000	12.65	31.71	44.36	54.00	-9.64	AVG	

REMARKS:

- (1) Measurement Value = Reading Level + Correct Factor.
- (2) Margin Level = Measurement Value - Limit Value.

Test Mode: TX N-40M Mode 2452 MHz

### Vertical

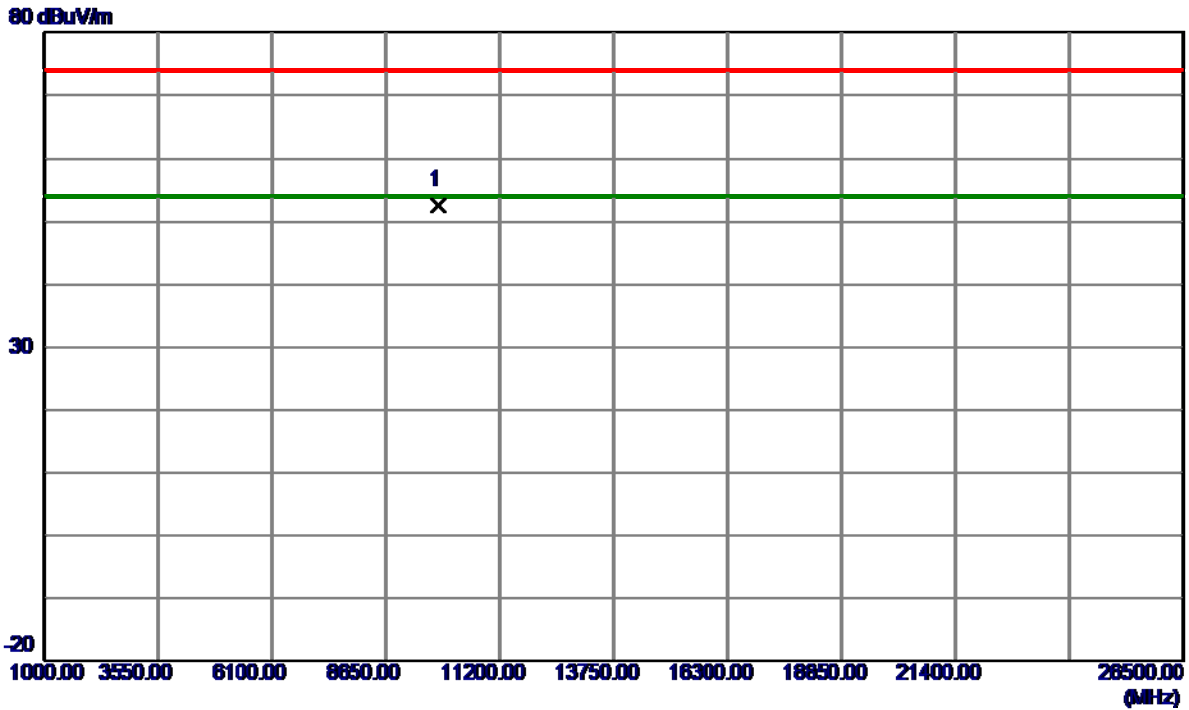

No.	Freq. MHz	Reading Level dBuV/m	Correct Factor dB	Measure ment dBuV/m	Limit dBuV/m	Margin dB	Detector	Comment
1 *	9808.0950	51.39	1.19	52.58	74.00	-21.42	Peak	

**REMARKS:**

- (1) Measurement Value = Reading Level + Correct Factor.
- (2) Margin Level = Measurement Value - Limit Value.

Test Mode: TX N-40M Mode 2452 MHz

### Horizontal

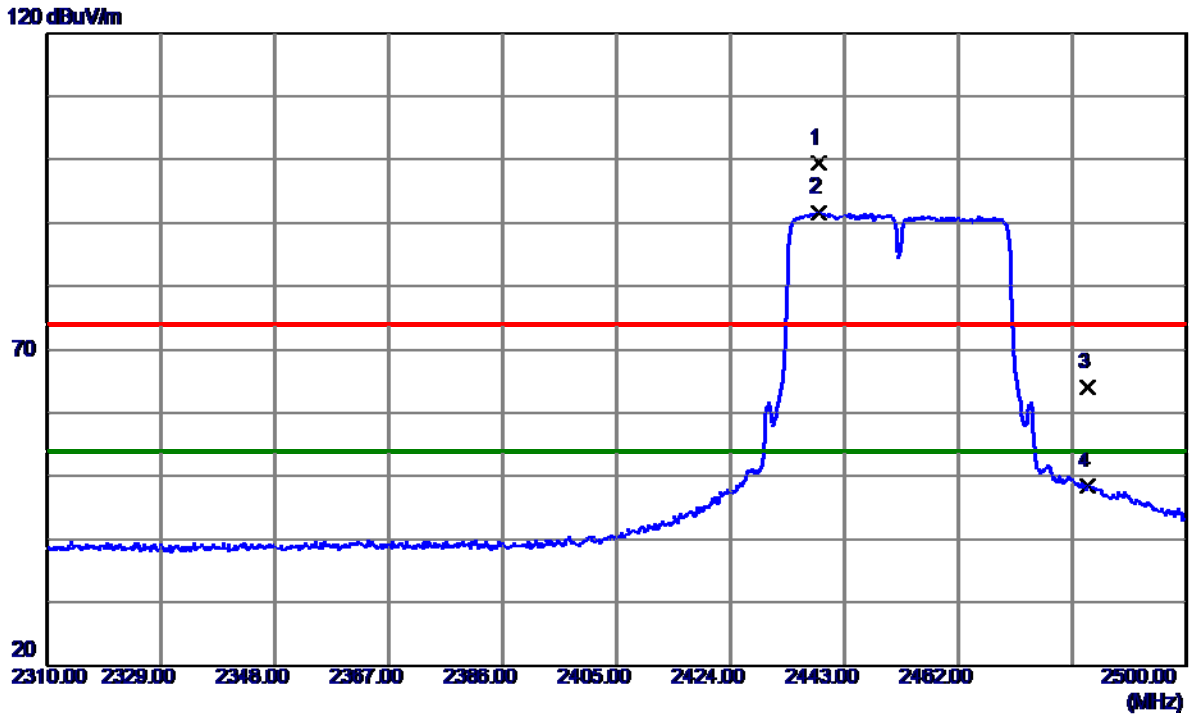

No.	Freq. MHz	Reading Level dBuV/m	Correct Factor dB	Measure ment dBuV/m	Limit dBuV/m	Margin dB	Detector	Comment
1	2438.6299	67.64	31.72	99.36	74.00	25.36	Peak	No limit
2 *	2438.6299	59.93	31.72	91.65	54.00	37.65	AVG	No limit
3	2483.5000	32.29	31.71	64.00	74.00	-10.00	Peak	
4	2483.5000	16.65	31.71	48.36	54.00	-5.64	AVG	

**REMARKS:**

- (1) Measurement Value = Reading Level + Correct Factor.
- (2) Margin Level = Measurement Value - Limit Value.

Test Mode: TX N-40M Mode 2452 MHz

### Horizontal

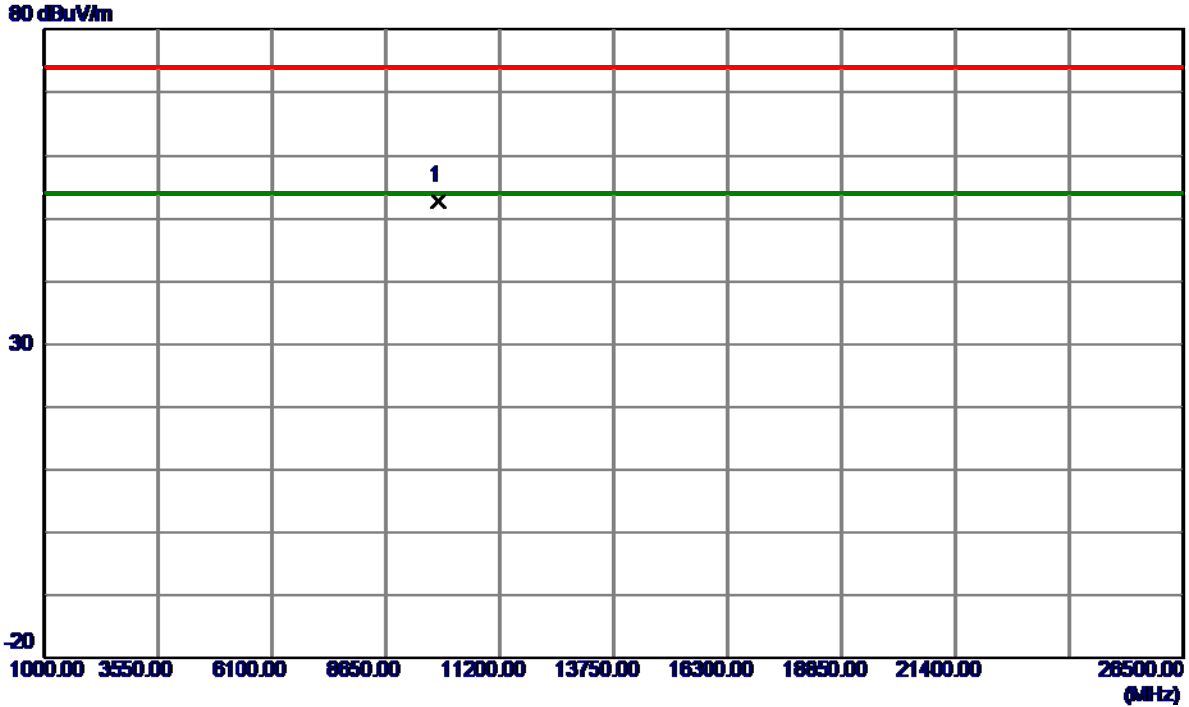

No.	Freq. MHz	Reading Level dBuV/m	Correct Factor dB	Measure ment dBuV/m	Limit dBuV/m	Margin dB	Detector	Comment
1 *	9808.1030	51.53	1.19	52.72	74.00	-21.28	Peak	

REMARKS:

- (1) Measurement Value = Reading Level + Correct Factor.
- (2) Margin Level = Measurement Value - Limit Value.

## APPENDIX E - BANDWIDTH

Test Mode	TX B Mode
-----------	-----------

Channel	Frequency (MHz)	6 dB Bandwidth (MHz)	6 dB Bandwidth Min. Limit (kHz)	Result
01	2412	8.59	500	Complies
06	2437	8.55	500	Complies
11	2462	9.04	500	Complies

CH01

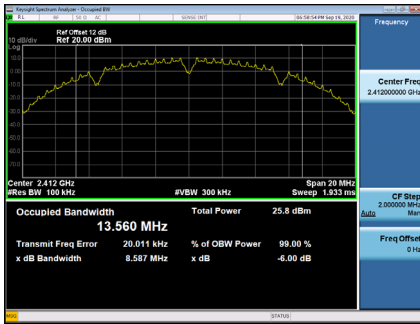

CH06

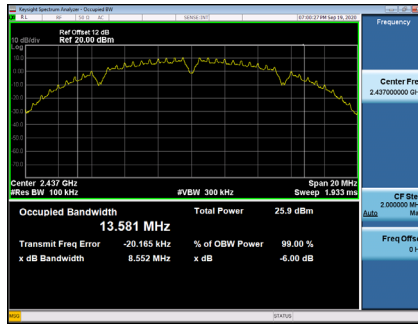

CH11

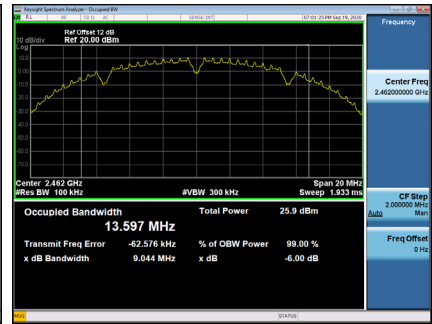

Channel	Frequency (MHz)	99 % Emission Bandwidth (MHz)	Result
01	2412	13.599	Complies
06	2437	13.609	Complies
11	2462	13.610	Complies

CH01

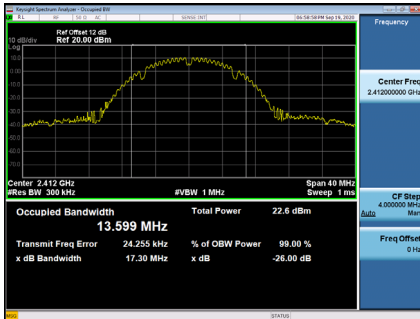

CH06

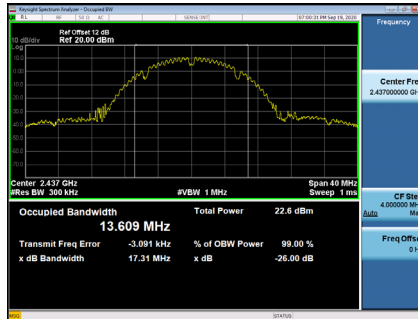

CH11

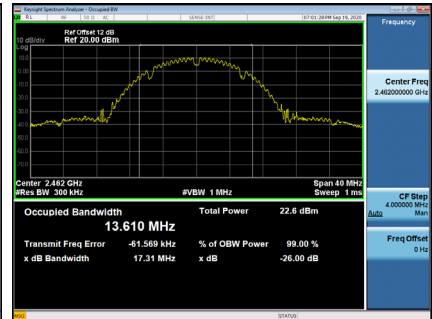

Test Mode	TX G Mode
-----------	-----------

Channel	Frequency (MHz)	6 dB Bandwidth (MHz)	6 dB Bandwidth Min. Limit (kHz)	Result
01	2412	16.40	500	Complies
06	2437	16.38	500	Complies
11	2462	16.38	500	Complies

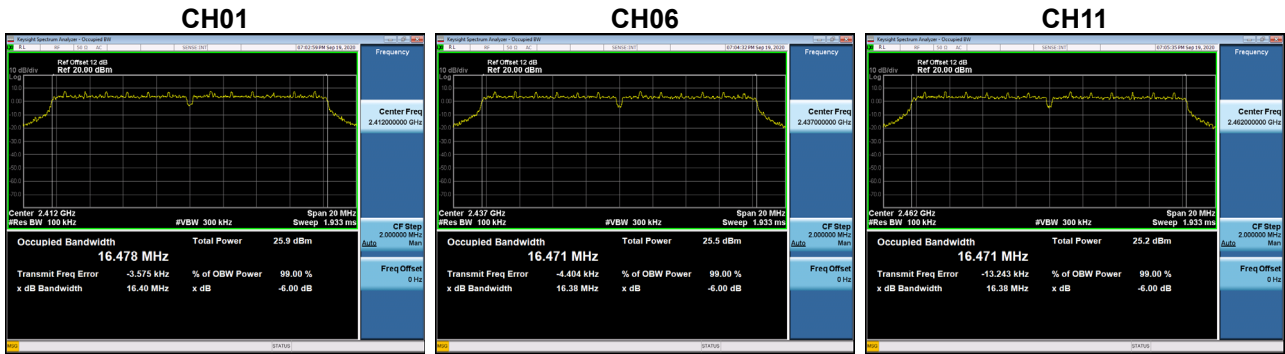

Channel	Frequency (MHz)	99 % Emission Bandwidth (MHz)	Result
01	2412	17.026	Complies
06	2437	16.975	Complies
11	2462	16.925	Complies

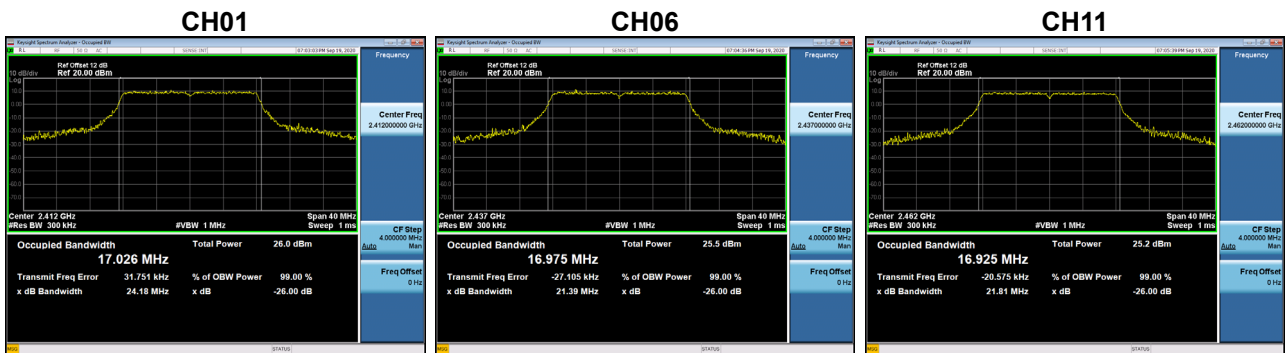



Test Mode	TX N-20M Mode
-----------	---------------

Channel	Frequency (MHz)	6 dB Bandwidth (MHz)	6 dB Bandwidth Min. Limit (kHz)	Result
01	2412	17.57	500	Complies
06	2437	17.57	500	Complies
11	2462	17.57	500	Complies

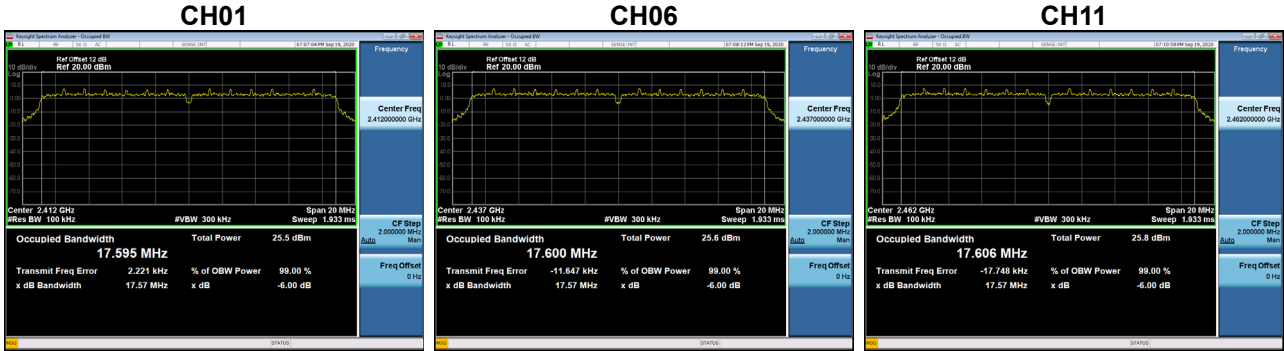

Channel	Frequency (MHz)	99 % Emission Bandwidth (MHz)	Result
01	2412	18.029	Complies
06	2437	18.031	Complies
11	2462	18.036	Complies

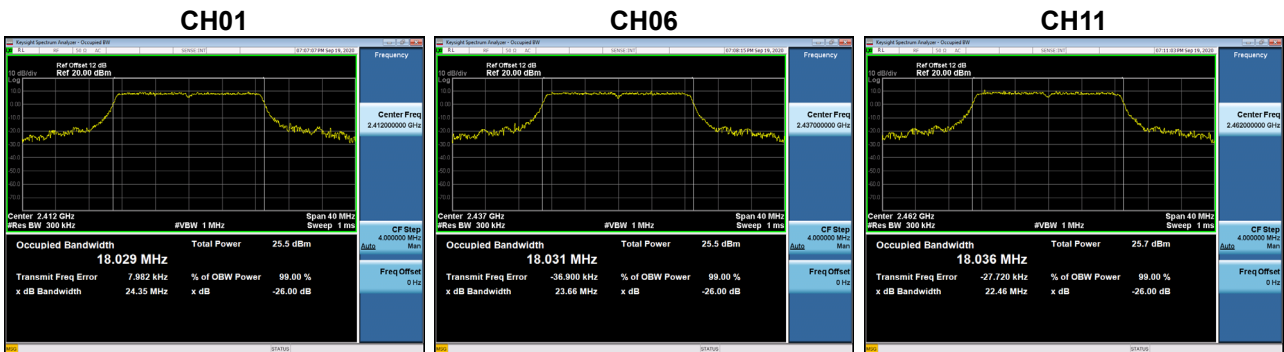

Test Mode	TX N-40M Mode
-----------	---------------

Channel	Frequency (MHz)	6 dB Bandwidth (MHz)	6 dB Bandwidth Min. Limit (kHz)	Result
03	2422	35.89	500	Complies
06	2437	36.06	500	Complies
09	2452	35.55	500	Complies

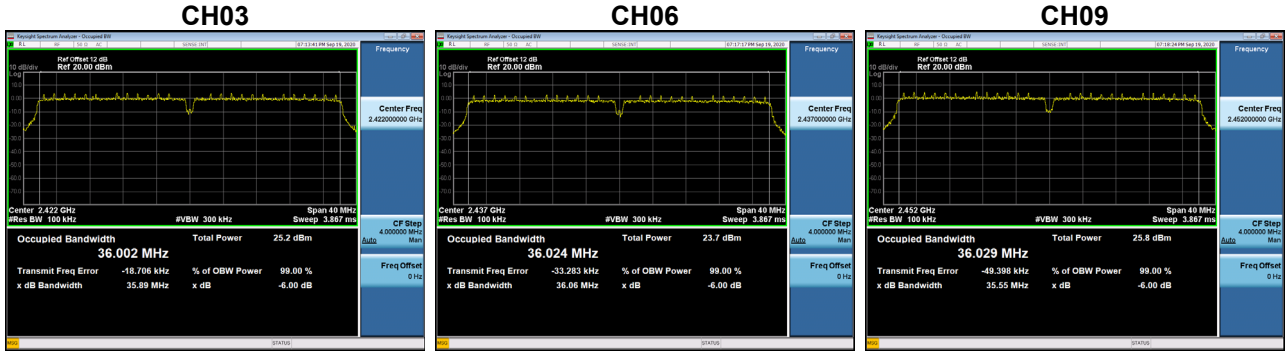

Channel	Frequency (MHz)	99 % Emission Bandwidth (MHz)	Result
03	2422	36.877	Complies
06	2437	36.793	Complies
09	2452	36.969	Complies

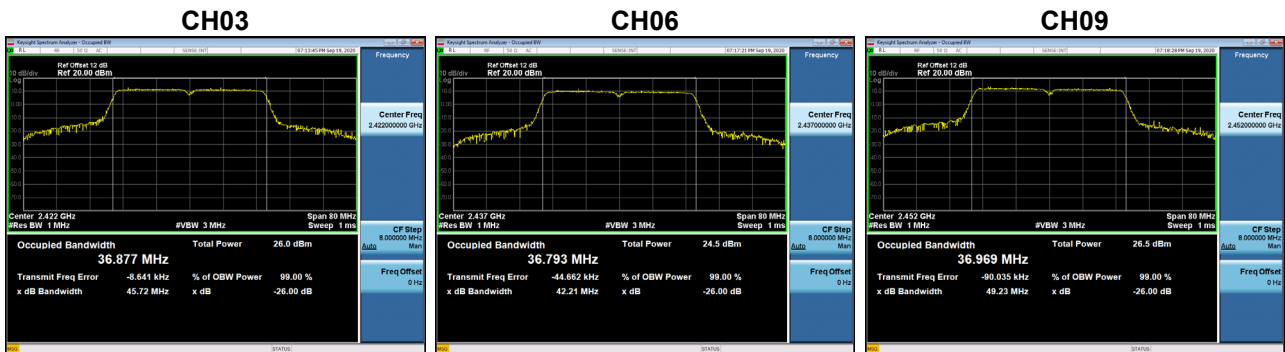

## **APPENDIX F - MAXIMUM OUTPUT POWER**

Test Mode	TX B Mode
-----------	-----------

Channel	Frequency (MHz)	Avg Output Power (dBm)	Duty Factor	Output Power + Duty Factor (dBm)	Max. Limit (dBm)	Max. Limit (W)	Result
01	2412	17.61	0.09	17.70	30.00	1.0000	Complies
06	2437	17.73	0.09	17.82	30.00	1.0000	Complies
11	2462	17.46	0.09	17.55	30.00	1.0000	Complies

Test Mode	TX G Mode
-----------	-----------

Channel	Frequency (MHz)	Avg Output Power (dBm)	Duty Factor	Output Power + Duty Factor (dBm)	Max. Limit (dBm)	Max. Limit (W)	Result
01	2412	17.43	0.49	17.92	30.00	1.0000	Complies
06	2437	17.48	0.49	17.97	30.00	1.0000	Complies
11	2462	17.48	0.49	17.97	30.00	1.0000	Complies

Test Mode	TX N-20M Mode
-----------	---------------

Channel	Frequency (MHz)	Avg Output Power (dBm)	Duty Factor	Output Power + Duty Factor (dBm)	Max. Limit (dBm)	Max. Limit (W)	Result
01	2412	17.55	0.27	17.82	30.00	1.0000	Complies
06	2437	17.43	0.27	17.70	30.00	1.0000	Complies
11	2462	17.49	0.27	17.76	30.00	1.0000	Complies

Test Mode	TX N-40M Mode
-----------	---------------

Channel	Frequency (MHz)	Avg Output Power (dBm)	Duty Factor	Output Power + Duty Factor (dBm)	Max. Limit (dBm)	Max. Limit (W)	Result
03	2422	16.27	1.35	17.62	30.00	1.0000	Complies
06	2437	15.32	1.35	16.67	30.00	1.0000	Complies
09	2452	16.53	1.35	17.80	30.00	1.0000	Complies

## **APPENDIX G - CONDUCTED SPURIOUS EMISSIONS**

Test Mode TX B Mode

### Bandedge-CH01



### Bandedge-CH11

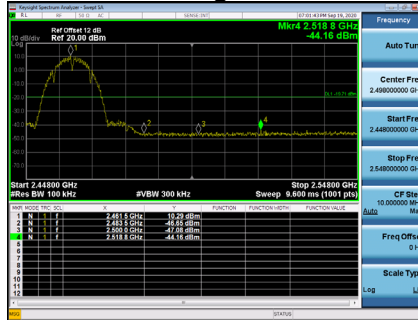

### CH01 – 10th Harmonic of the fundamental frequency

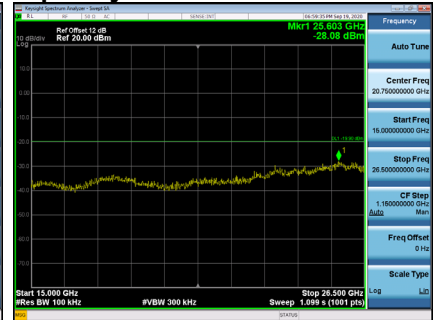
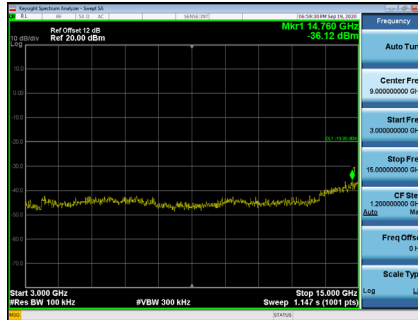
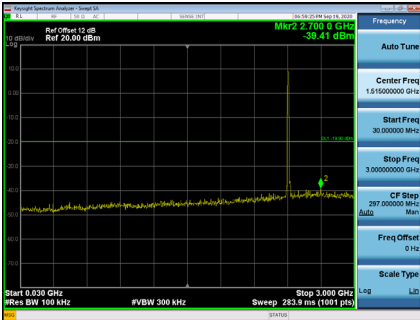

### CH06 – 10th Harmonic of the fundamental frequency

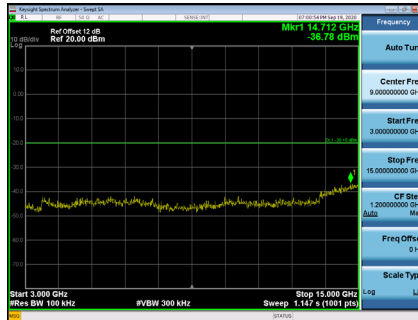
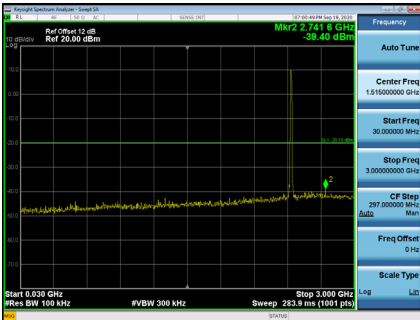

### CH11 – 10th Harmonic of the fundamental frequency

