



FCC Test Report

FCC ID: 2AG78ST88A

Product Name:	Mobile Phone
Trademark:	N/A
Model Name:	ST88A 215, QS150, 105, Tech Motion, Titanium, 225
Prepared For:	Beijing Sogou Technology Development Co.,Ltd.
Address:	19F, West Wing of Tower D, Tsinghua TongFang Hi-tech Plaza, No 1 Wangzhuang Road, Haidian District, Beijing, China
Prepared By:	Shenzhen BCTC Technology Co., Ltd.
Address:	No.101, Yousong Road, Longhua New District, Shenzhen, China
Test Date:	Jan. 8 –Jan. 15, 2016
Date of Report:	Jan. 15, 2016
Report No.:	BCTC-160100338E-2



VERIFICATION OF COMPLIANCE

Applicant's name : **Golden Unions Limited**
Address : UNIT 1010, MIRAMAR TOWER, 132 NATHAN ROAD,
 TSIMSHATSUI, KL, HongKong

Manufacture's Name..... : **Golden Unions Limited**
Address : UNIT 1010, MIRAMAR TOWER, 132 NATHAN ROAD,
 TSIMSHATSUI, KL, HongKong

Product description

Product name : **Mobile Phone**
Trademark: **N/A**
Model Name: **ST88A**
215, QS150, 105, Tech Motion, Titanium, 225
 FCC CFR Title 47 Part 2: 2014

Test procedure : FCC CFR Title 47 Part22 Subpart H: 2014
 FCC CFR Title 47 Part24 Subpart E: 2014

This device described above has been tested by BCTC, and the test results show that the equipment under test (EUT) is in compliance with the requirements. And it is applicable only to the tested sample identified in the report.

This report shall not be reproduced except in full, without the written approval of BCTC, this document may be altered or revised by BCTC, personal only, and shall be noted in the revision of the document.

Test Result : **Pass**

Testing Engineer : Eric Yang
 (Eric Yang)

Technical Manager : Sophie Lu
 (Sophia Lee)

Authorized Signatory : Carson Zhang
 (Carson. Zhang)





TABLE OF CONTENTS

	Page
Test Report Declaration	
1. TEST SUMMARY	4
2. GENERAL PRODUCT INFORMATION	5
2.1. Product Function	5
2.2. Description of Device (EUT)	5
2.3. Difference between Model Numbers	6
2.4. Test Supporting System	6
2.5. Independent Operation Modes	6
3. TEST SITES	7
3.1. Test Facilities	7
3.2. List of Test and Measurement Instruments	8
4. TEST SET-UP AND OPERATION MODES	9
4.1. Principle of Configuration Selection.....	9
4.2. Block Diagram of Test Set-up.....	9
4.3. Test Operation Mode and Test Software	9
4.4. Special Accessories and Auxiliary Equipment	9
4.5. Countermeasures to Achieve EMC Compliance	9
4.6. Test Environment:	9
5. EMISSION TEST RESULTS	10
5.1. Conducted RF Output Power	10
5.2. Peak to Average Ratio	11
5.3. -26dB and 99% Occupied Bandwidth.....	13
5.4. Frequency Stability	16
5.5. Conducted Spurious Emissions	18
5.6. Conducted Out of Band Emissions.....	25
5.7. Transmitter Radiated Power (EIRP/ERP)	28
5.8. Radiated Out of Band Emissions	32
5.9. CONDUCTED EMISSION MEASUREMENT	36
6. PHOTOGRAPHS OF TEST SET-UP	40
7. PHOTOGRAPHS OF THE EUT	42



1. TEST SUMMARY

Test Items	Test Requirement	Result
RF Exposure (SAR)	Part 1.1307 Part 2.1093	Passed* (Please refer to SAR Report)
Conducted RF Output Power	2.1046	PASS
Peak to Average Ratio	2.1055,22.355 24.235,27.54	PASS
99% & -26 dB Occupied Bandwidth	2.1049, 22.917 24.238,	PASS
Frequency Stability	2.1055, 22.355 24.235,	PASS
Conducted Out of Band Emissions	2.1051,2.1057 22.917, 24.238	PASS
Band Edge	2.1051,2.1057 22.917, 24.238	PASS
Transmitter Radiated Power (EIPR/ERP)	22.913, 24.232	PASS
Radiated Out of Band Emissions	2.1053,2.1057 22.917, 24.238	PASS



2. GENERAL PRODUCT INFORMATION

2.1. Product Function

Refer to Technical Construction Form and User Manual.

2.2. Description of Device (EUT)

Product Name:	Mobile Phone
Model No.:	ST88A 215, QS150, 105, Tech Motion, Titanium, 225
Operation Frequency:	GSM 850MHz: Tx: 824.20 - 848.80MHz (at intervals of 200kHz); Rx: 869.20 - 893.80MHz (at intervals of 200kHz) GSM 1900MHz: Tx: 1850.20 - 1909.80MHz (at intervals of 200kHz); Rx: 1930.20 - 1989.80MHz (at intervals of 200kHz) BT:2402~2480MHz
Modulation technology:	GSM/GPRS Mode with GMSK BT:GFSK
BT Version	2.0
Antenna Type:	Integral Antenna
Antenna gain:	1.5dBi(GSM850/1900) 1.0 dBi(BT)
Power supply:	DC 5V from adapter Rechargeable lithium-ion battery 3.8V
GPRS Class:	12
Adapter	Model: ST88A I/P:100-240V 50/60Hz 0.35A O/P: DC 5.5V/0.5A Max
Connecting I/O Port(s)	Please refer to the User's Manual
hardware version	--
Software version	--
Serial number	--



2.3. Difference between Model Numbers

The product are different for mode names, outlook color, screen size and panel material.

2.4. Test Supporting System

None.

2.5. Independent Operation Modes

During all testing, EUT is in link mode with base station emulator at maximum power level. The spurious emission measurements were carried out in semi-anechoic chamber with 3-meter test range, and EUT is rotated on three test planes to find out the worst emission.

Test modes		
Band	Radiated	Conducted
GSM 850	<ul style="list-style-type: none"> ■ GSM link ■ GPRS 8 link 	<ul style="list-style-type: none"> ■ GSM link ■ GPRS 8 link
PCS 1900	<ul style="list-style-type: none"> ■ GSM link 	<ul style="list-style-type: none"> ■ GSM link

Note: The maximum power levels are GSM mode for GMSK link.

The conducted average power tables are as follows:

Conducted Average Power (dBm)						
Band	GSM850			PCS1900		
Channel	128	190	251	512	661	810
Frequency (MHz)	824.20	836.60	848.80	1850.20	1880.00	1909.80
GSM SIM1	32.15	32.59	32.94	30.86	30.64	30.77
GSM SIM2	32.06	32.31	32.78	30.27	30.35	30.24

Note: The worst mode was in SIM1, all test data in SIM1 mode in this report.



3. TEST SITES

3.1. Test Facilities

Shenzhen BCTC Technology Co., Ltd.

Add.:No.101,Yousong Road,Longhua New District, Shenzhen,China

FCC Registration No.:187086

3.1.1. Measurement Uncertainty

The reported uncertainty of measurement $y \pm U$, where expanded uncertainty U is based on a standard uncertainty multiplied by a coverage factor of $k=2$, providing a level of confidence of approximately **95** %.

No.	Item	Uncertainty
1	Conducted Emission Test	$\pm 1.38\text{dB}$
2	RF power,conducted	$\pm 0.16\text{dB}$
3	Spurious emissions,conducted	$\pm 0.21\text{dB}$
4	All emissions,radiated(<1G)	$\pm 4.68\text{dB}$
5	All emissions,radiated(>1G)	$\pm 4.89\text{dB}$
6	Temperature	$\pm 0.5^{\circ}\text{C}$
7	Humidity	$\pm 2\%$



3.2. List of Test and Measurement Instruments

3.2.1. For conducted emission at the mains terminals test

Equipment	Manufacturer	Model No.	Serial No.	Last Cal.	Next Cal.
Test Receiver	R&S	ESCI	101160	2015.06.07	2016.06.06
LISN	SCHWARZBECK	ENV216	101313	2015.08.25	2016.08.24
LISN	EMCO	3816/2	00042990	2015.08.25	2016.08.24
50Ω Coaxial Switch	Anritsu	MP59B	6200264417	2015.06.07	2016.06.06
RF cables	R&S	R204	R20X	2015.07.06	2015.07.05

3.2.2. For radiated emission test

Equipment	Manufacturer	Model No.	Serial No.	Last Cal.	Next Cal.
Test Receiver	R&S	ESPI	101318	2015.06.07	2016.06.06
System Simulator	Agilent	E5515C	GB43130252	2015.06.07	2016.06.06
Power Splitter	Weinschel	1506A	NW534	2015.06.07	2016.06.06
Bilog Antenna	TESEQ	CBL6111D	31216	2015.07.06	2016.07.05
Bilog Antenna	TESEQ	CBL6111D	31217	2015.06.07	2017.06.06
Loop antenna	ARA	PLA-1030/B	1029	2015.06.07	2016.06.06
Spectrum Analyzer	Agilent	E4411B	MY4511235	2015.07.06	2016.07.05
Signal Amplifier	SONOMA	313	187022	2015.07.06	2016.07.05
Signal Amplifier	Agilent	8449B	3008A00213	2015.07.06	2016.07.05
RF Cable	R&S	R203	R20X	2015.07.06	2016.07.05
MULTI-DEVICE Controller	ETS-LINDGREEN	31250	126821	N/A	N/A
Horn Antenna	EM	EM-AH-10180	2011071402	2015.07.06	2016.07.05
Horn Antenna	EM	EM-AH-10180	2011071401	2015.06.07	2017.06.06
Horn Antenna	Schwarzbeck	BBHA 9170	9170-181	2015.07.06	2016.07.05
Spectrum Analyzer	Agilent	8593E	3911A03928	2015.07.06	2016.07.05
Spectrum Analyzer	Agilent	E4407B	MY45108040	2015.07.06	2016.07.05
Signal Amplifier	DAZE	ZN3380B	11235	2015.08.25	2016.08.24
High Pass filter	KANGMAI	WHKX1.0/1.5G-10SS	40	2015.08.25	2016.08.24
Filter	COM-MW	ZBSF-C836.5-25-X	BCTC042	2015.08.25	2016.08.24
Filter	COM-MW	ZBSF-C1747.5-75-X2	BCTC045	2015.08.25	2016.08.24
Filter	COM-MW	ZBSF-C1880-60-X2	BCTC047	2015.08.25	2016.08.24
DC Power Supply	LongWei	PS-305D	010965682	2015.07.06	2016.07.05
Constant temperature and humidity box	GF	GTH-800-40-2P	MAA9906-012	2015.06.07	2016.06.06
Universal radio communication tester	R&S	CMU200	115295	2015.08.25	2016.08.24
Splitter	Agilent	11435B	1125162	2015.07.06	2016.07.05

4. TEST SET-UP AND OPERATION MODES

4.1. Principle of Configuration Selection

Emission: The equipment under test (EUT) was configured to measure its highest possible radiation level. The test modes were adapted accordingly in reference to the Operating Instructions.

4.2. Block Diagram of Test Set-up

System Diagram of Connections between EUT and Simulators

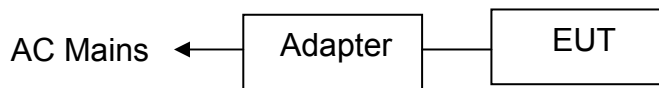

(EUT: Mobile Phone)

4.3. Test Operation Mode and Test Software

None.

4.4. Special Accessories and Auxiliary Equipment

None.

4.5. Countermeasures to Achieve EMC Compliance

None.

4.6. Test Environment:

Ambient conditions in the test laboratory:

Items	Actual
Temperature (°C)	21~23
Humidity (%RH)	50~65



5. EMISSION TEST RESULTS

5.1. Conducted RF Output Power

5.1.1. Limit

According to FCC section 2.1046(a) , FCC part22.913(a) and FCC part24.232(b) ,for transmitters other than single sideband, independent sideband and controlled carrier radiotelephone, power output shall be measured at the RF output terminals when the transmitter is adjusted in accordance with the tune-up procedure to give the values of current and voltage on the circuit elements specified in FCC section 2.1033(c)(8).

5.1.2. Test Setup

The EUT, which is powered by the adapter, is coupled to the Spectrum Analyzer (SA) and the System Simulator (SS) with Attenuators through the Power Splitter; the RF load attached to the EUT antenna terminal is 50Ohm; the path loss as the factor is calibrated to correct the reading. The EUT is commanded by the SS to operate at the maximum output power.

5.1.3. Test Result

Here the lowest, middle and highest channels are selected to perform testing to verify the conducted RF output power of the EUT.

Measurement data

The conducted power tables are as follows:

Average Conducted Power (dBm)						
Band	GSM850			PCS1900		
Frequency	824.20	836.60	848.80	1850.20	1880.00	1909.80
GSM (GMSK, 1 TX slot)	32.15	32.59	32.94	30.86	30.64	30.77
GPRS (GMSK, 1 TX slot)	31.25	31.43	31.37	30.43	30.82	30.78
GPRS (GMSK, 2 TX slot)	30.24	30.75	30.39	29.86	29.64	29.59
GPRS (GMSK, 3 TX slot)	28.29	28.80	28.63	28.53	28.60	28.54
GPRS (GMSK, 4 TX slot)	27.62	27.68	27.92	27.49	27.52	27.46
Limit	38.45			33.01		
Result	Pass					

Note: Measurement Uncertainty: ± 2.6 dB.



5.2. Peak to Average Ratio

5.2.1. Limit

According to FCC section 27.50(d)(5) , the peak to average ratio(PAR) of the transmission may not exceed 13dB.

5.2.2. Test Setup

See section 5.1.2 of this report.

5.2.3. Test Result

Measurement data as follows:

Band	PCS1900		
	Low	Middle	High
Frequency	1850.20	1880.00	1909.8
Peak-to average ratio(dB)/GSM	9.84	10.13	11.35

Note: Measurement Uncertainty: ± 0.2 dB.

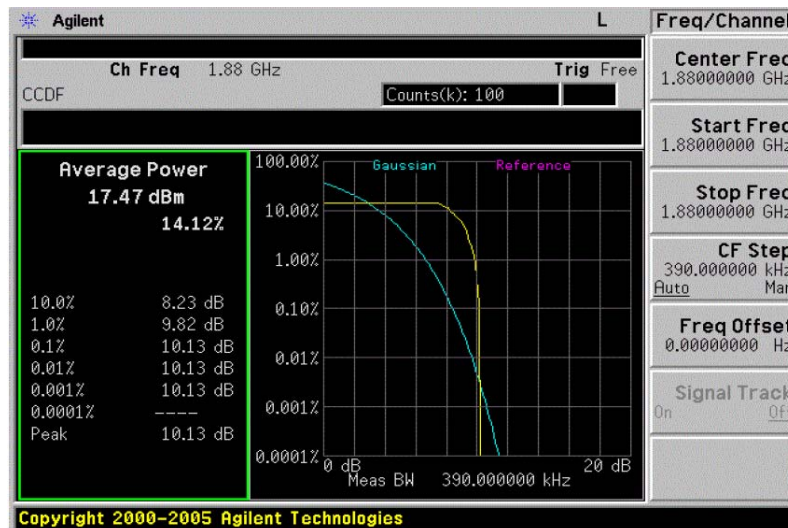
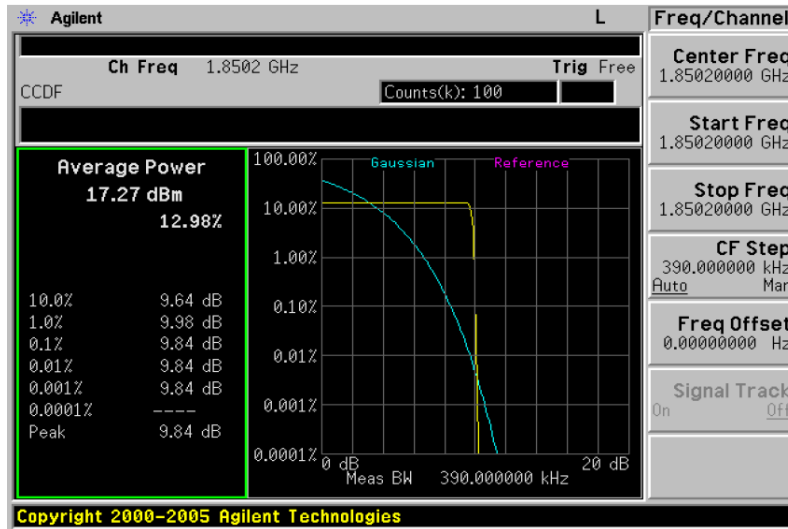



5.3. -26dB and 99% Occupied Bandwidth

5.3.1. Limit

According to FCC section 2.1049 and FCC part22.913(a) and FCC part24.232(b), the occupied bandwidth is the frequency bandwidth such that, below its lower and above its upper frequency limits, the mean powers radiated are each equal to 0.5 percent of the total mean power radiated by a given emission.

Occupied bandwidth is also known as the 99% emission bandwidth,

5.3.2. Test Setup

The EUT, which is powered by the adapter, is coupled to the Spectrum Analyzer (SA) and the System Simulator (SS) with Attenuators through the Power Splitter; the RF load attached to the EUT antenna terminal is 50Ohm; the path loss as the factor is calibrated to correct the reading. The EUT is commanded by the SS to operate at the maximum output power.

5.3.3. Test Result

Measurement Data

EUT Mode	Frequency (MHz)	99% Occupy bandwidth (kHz)	26dB Occupy bandwidth (kHz)
GSM 850 (GSM link)	824.20	243.409	316.784
	836.60	244.502	317.716
	848.80	242.695	319.363
PCS 1900 (GSM link)	1850.20	240.473	318.626
	1880.00	243.305	317.722
	1909.80	241.316	318.644

Note: Measurement Uncertainty: $\pm 20\text{Hz}$.



Test plot as follows:

GSM 850MHz Lowest channel

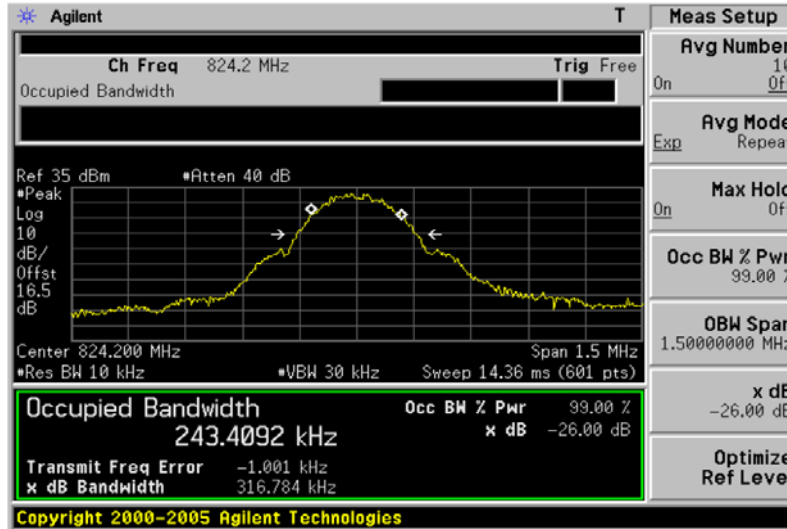

GSM 850MHz Middle channel

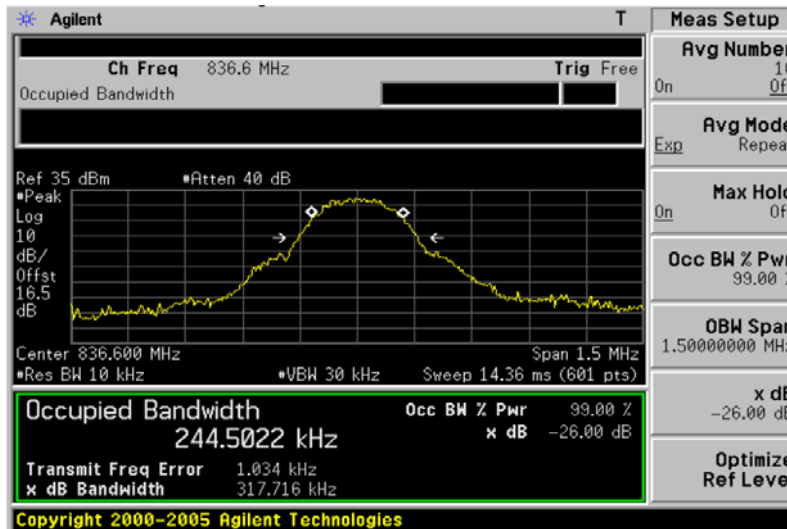

GSM 850MHz Highest channel:

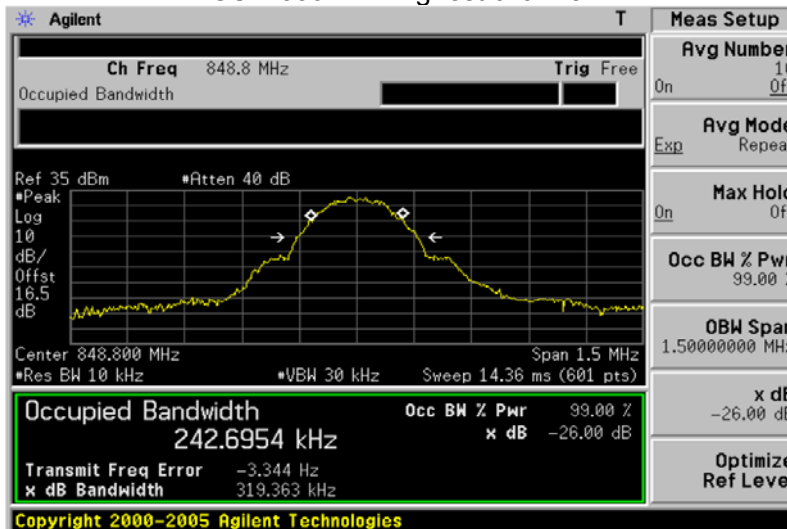



PCS 1900 (GSM link) Lowest channel

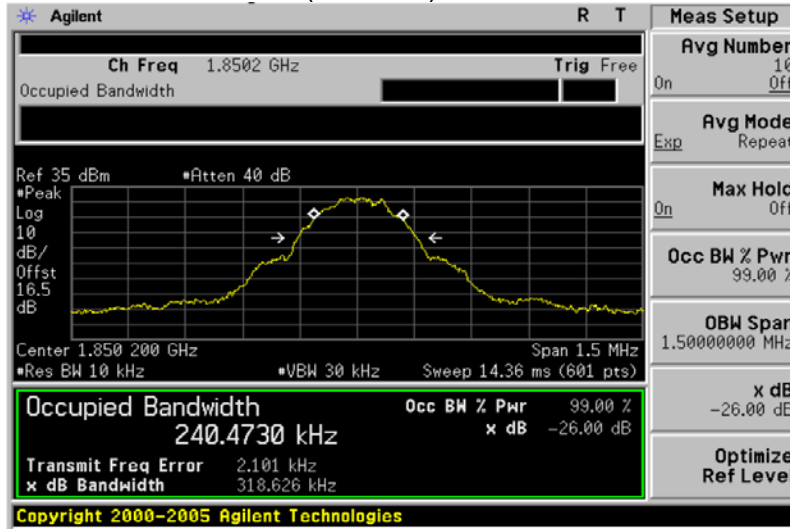

PCS 1900 (GSM link) Middle channel

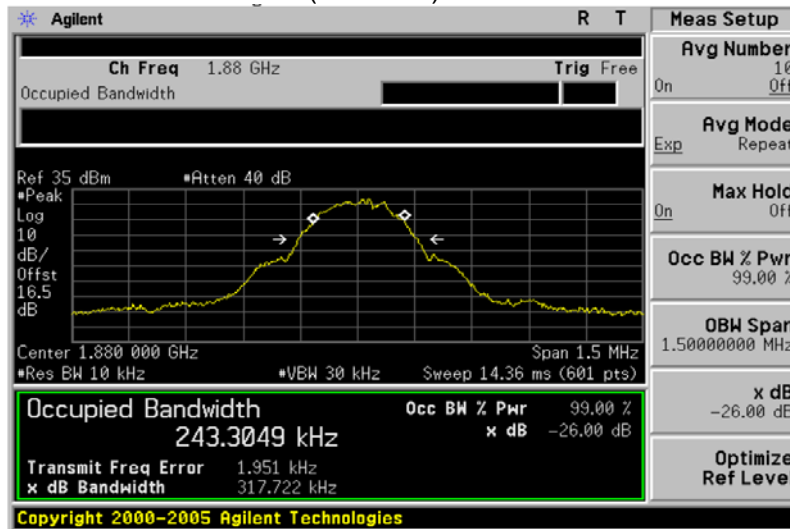

PCS 1900 (GSM link) Highest channel

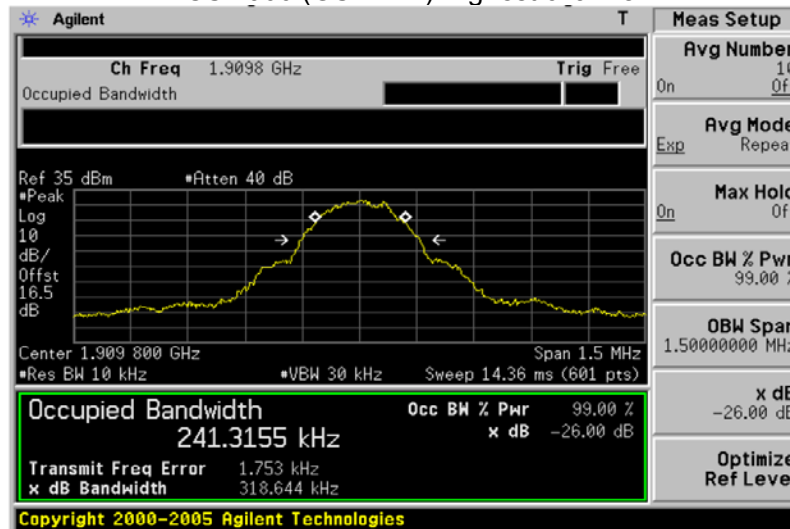

5.4. Frequency Stability

5.4.1. Limit

According to FCC section 22.355 and FCC section 24.235, the frequency stability shall be sufficient to ensure that the fundamental emission stays within the authorized frequency block. According to FCC section 2.1055, the test conditions are:

- (a) The temperature is varied from -30°C to $+50^{\circ}\text{C}$ at intervals of not more than 10°C .
- (b) For hand carried battery powered equipment, the primary supply voltage is reduced to the battery operating end point which shall be specified by the manufacture. The supply voltage shall be measured at the input to the cable normally provided with the equipment, or at the power supply terminals if cables are not normally provided.

5.4.2. Test Setup

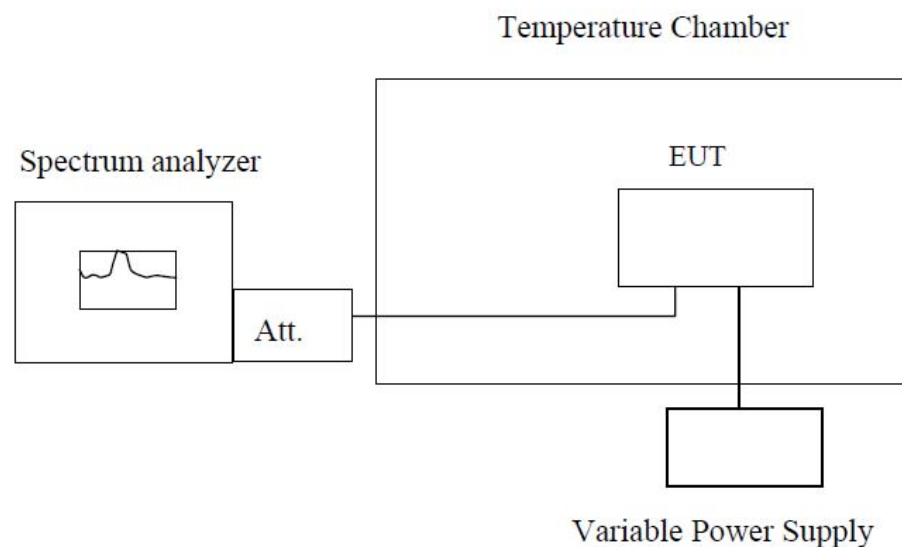

Note : Measurement setup for testing on Antenna connector

The EUT, which is powered by the DC Power Supply directly, is located in the Temperature Chamber.

The EUT is commanded by the System Simulator (SS) to operate at the maximum output power

5.4.3. Test Result

The nominal, highest and lowest extreme voltages are separately 3.8VDC, 4.2VDC and 3.6VDC which are specified by the applicant; the normal temperature here used is 25°C . The frequency deviation limit of 850MHz band is $\pm 2.5\text{ppm}$, and 1900MHz is $\pm 1\text{ppm}$



Normal

Test Conditions			Frequency Deviation			Result
Band	Power(Vdc)	Temperature(°C)	Frequency Error(Hz)	ppm	Limit	
GSM850 (GSM link) Middle channel=190 channel=836. 6MHz	3.7	-30	42	0.0502	±2.5	PASS
	3.7	-20	33	0.0394		
	3.7	-10	30	0.0359		
	3.7	0	38	0.0454		
	3.7	10	26	0.0311		
	3.7	20	22	0.0263		
	3.7	30	37	0.0442		
	3.7	40	45	0.0538		
	3.7	50	27	0.0323		
	4.25	25	25	0.0299		
	3.70	25	17	0.0203		
	3.40	25	33	0.0394		

Test Conditions			Frequency Deviation			Result
Band	Power(Vdc)	Temperature(°C)	Frequency Error(Hz)	ppm	Limit	
PCS1900 (GSM link) Middle channel=661 channel=188 0MHz	3.7	-30	89	0.0473	±1	PASS
	3.7	-20	53	0.0282		
	3.7	-10	64	0.0340		
	3.7	0	82	0.0436		
	3.7	10	37	0.0197		
	3.7	20	28	0.0149		
	3.7	30	37	0.0197		
	3.7	40	26	0.0138		
	3.7	50	68	0.0362		
	4.25	25	43	0.0229		
	3.70	25	24	0.0128		
	3.40	25	69	0.0367		

Note: Measurement Uncertainty: ±20Hz.

5.5. Conducted Spurious Emissions

5.5.1. Limit

According to FCC section 22.917(a) and FCC section 24.238(a), the power of any emission outside of the authorized operating frequency ranges must be attenuated below the transmitting power (P) by a factor of at least $43+10*\log(P)$ dB. This calculated to be -13dBm.

5.5.2. Test Setup

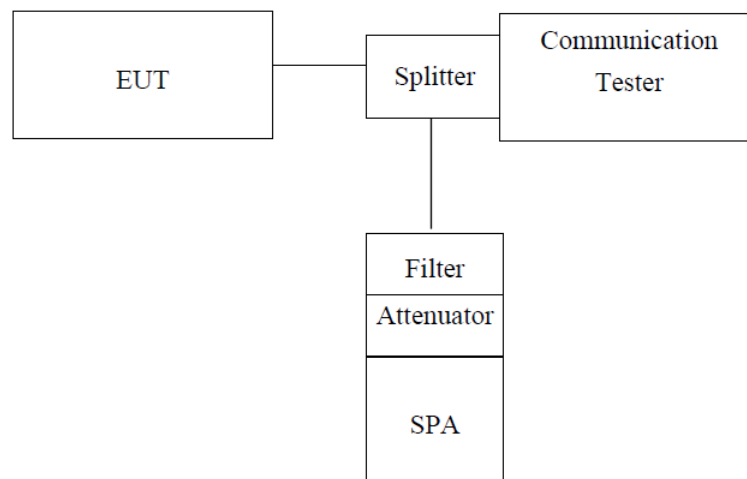

Note: Measurement setup for testing on Antenna connector

5.5.3. Measurement Procedure

The RF output of the transceiver was connected to a spectrum analyzer through appropriate attenuation. The resolution bandwidth of the spectrum analyzer was set at 1MHz, sufficient scans were taken to show the out of band Emissions if any up to 10th harmonic.

For the out of band: Set the RBW, VBW = 100KHz, Start=30MHz, Stop= 10th harmonic.

Limit = -13dBm

5.5.4. Test Result

The measurement frequency range is from 30MHz to the 10th harmonic of the fundamental frequency. The lowest, middle and highest channels are tested to verify the out of band emissions.

Test plot as follows:



GSM 850MHz Lowest channel

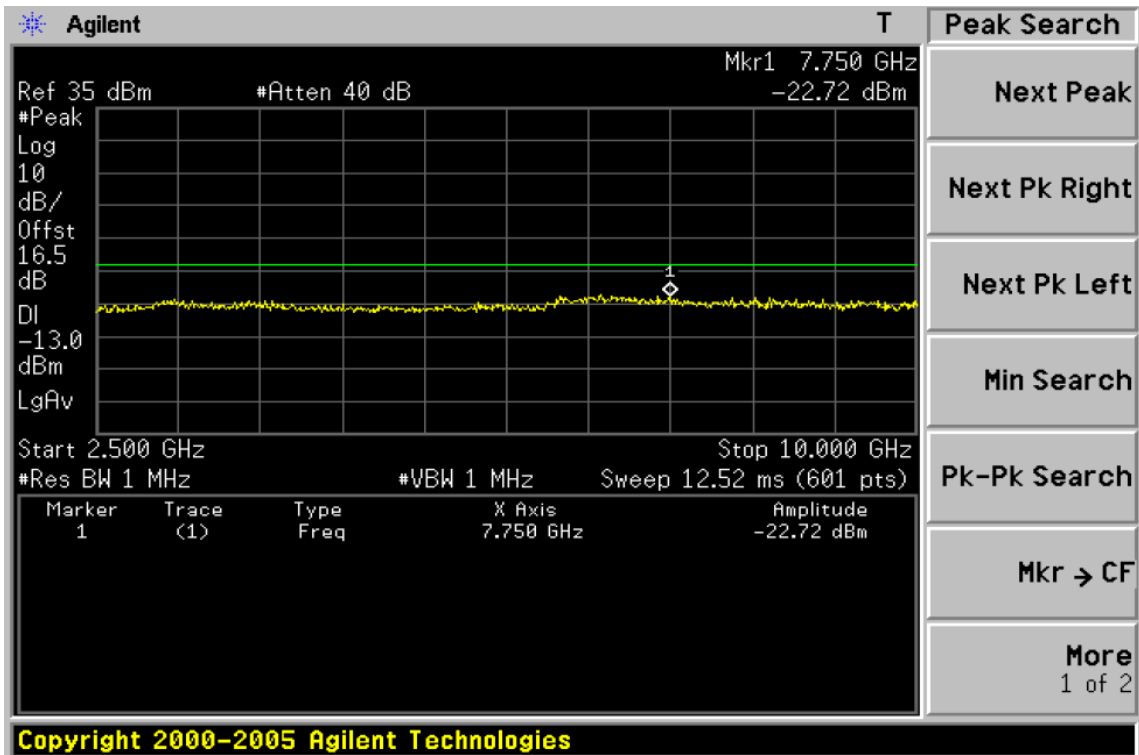
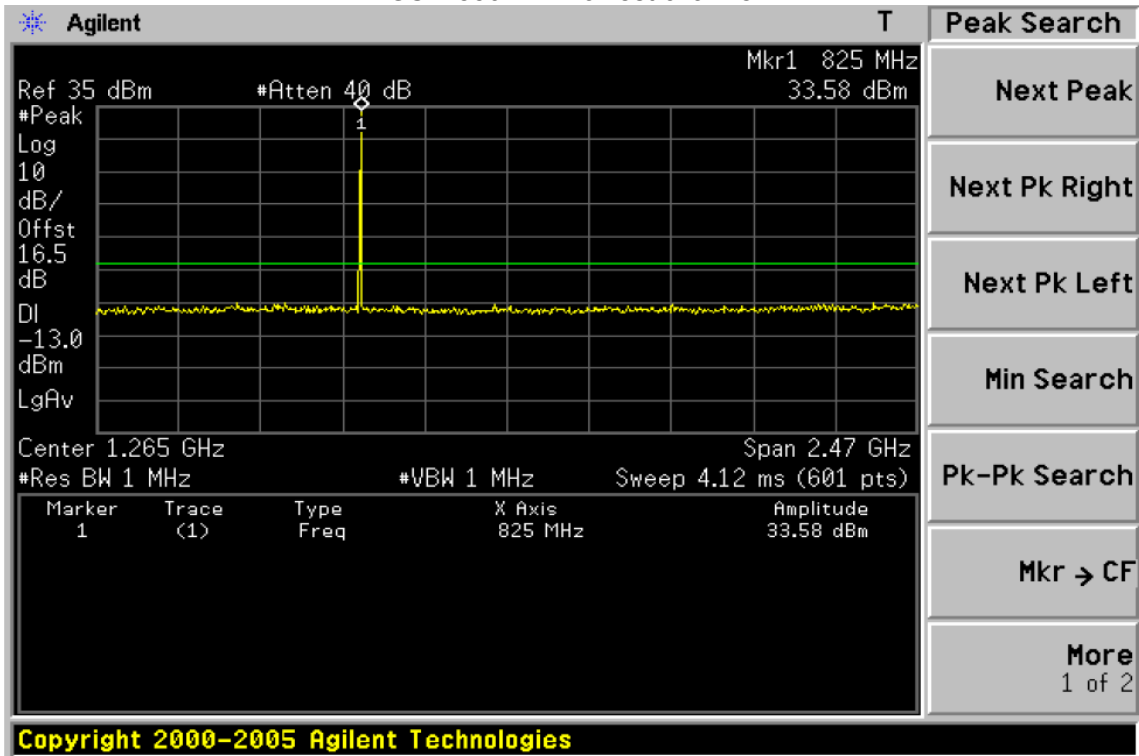



GSM 850MHz Middle channel

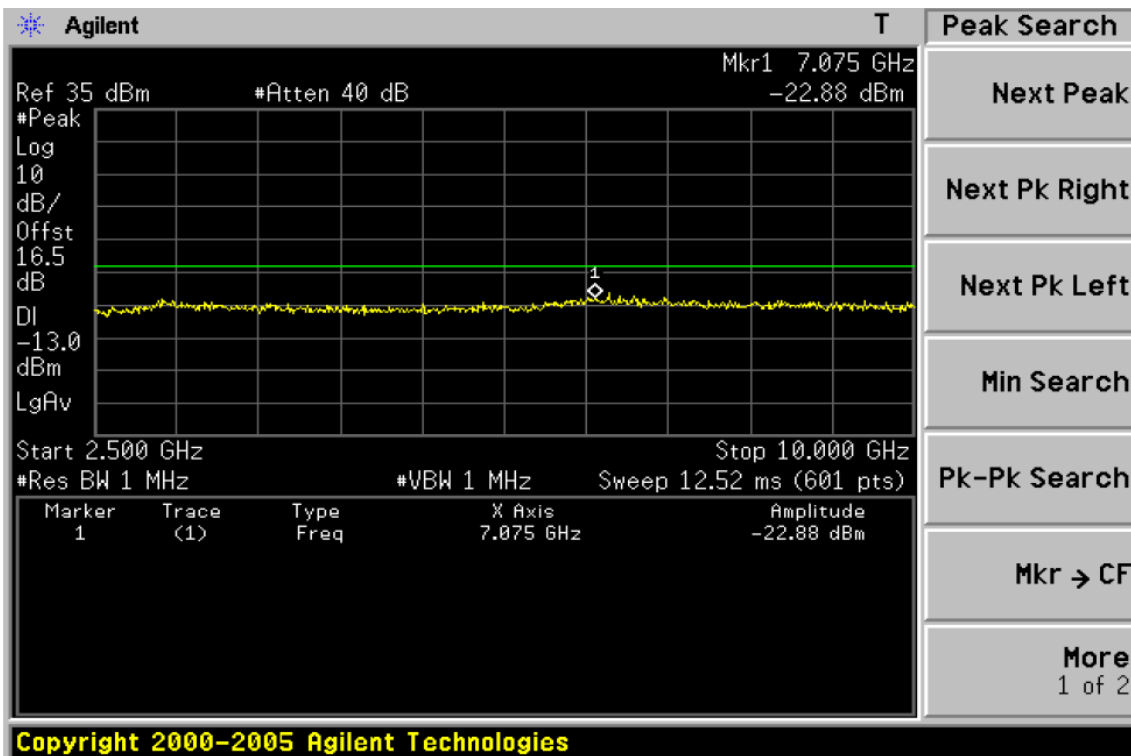
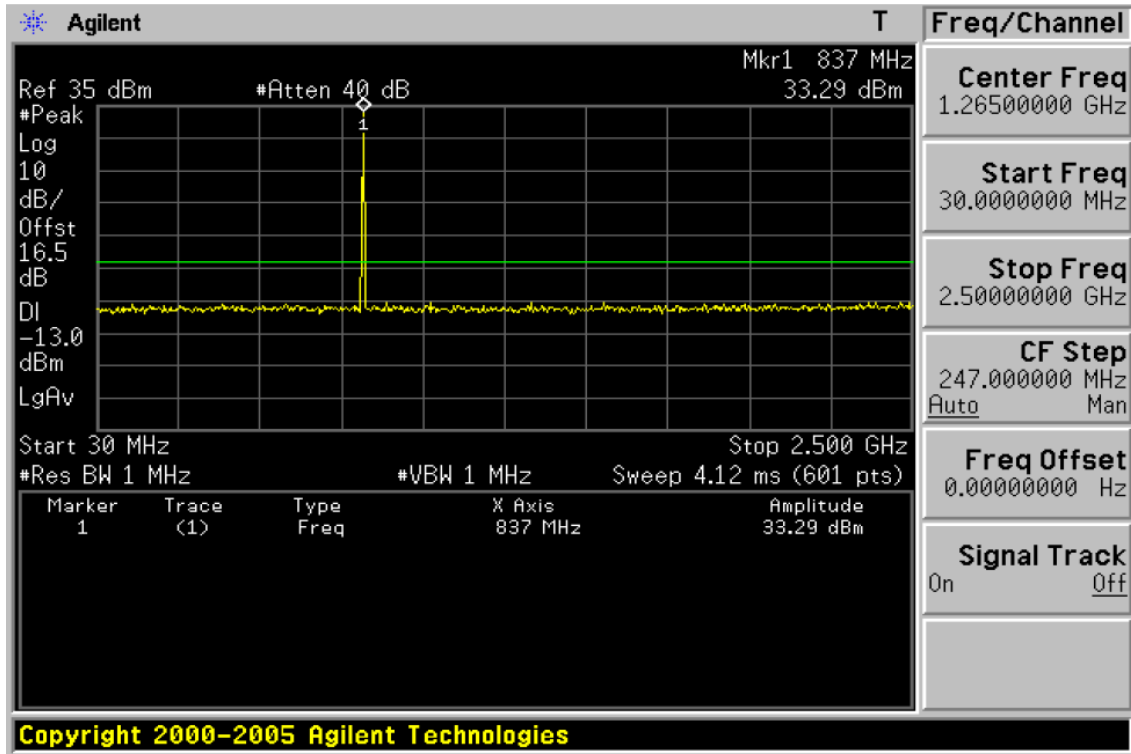



GSM 850MHz Highest channel

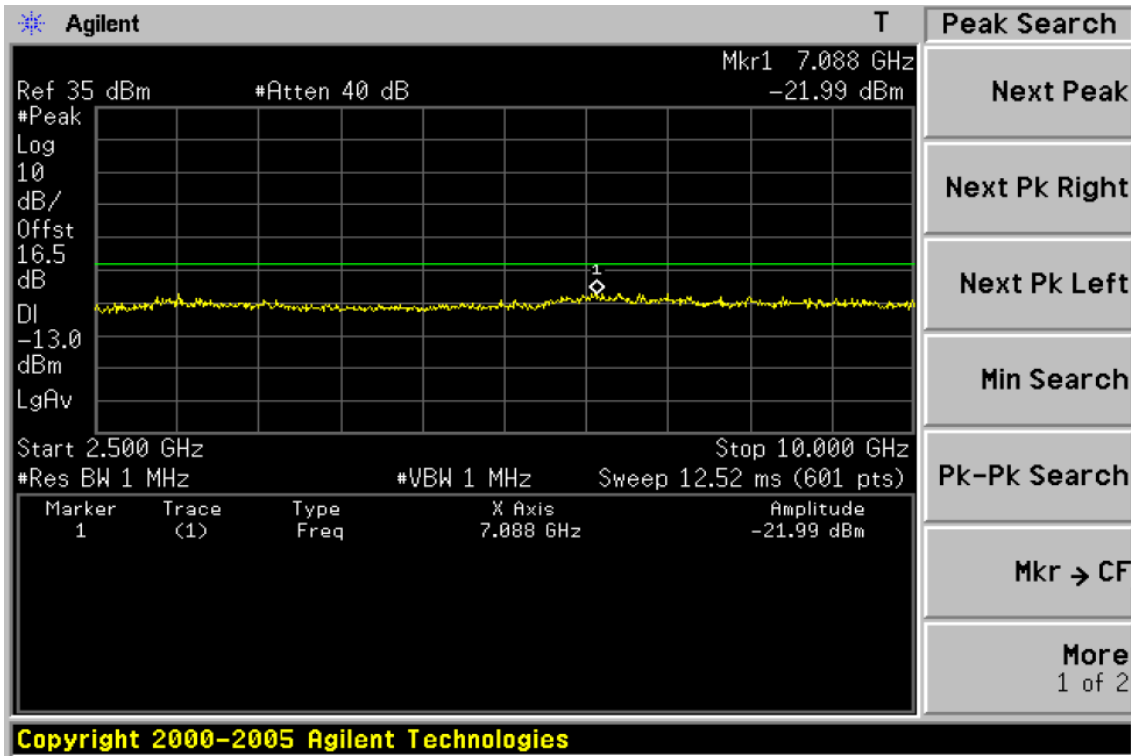
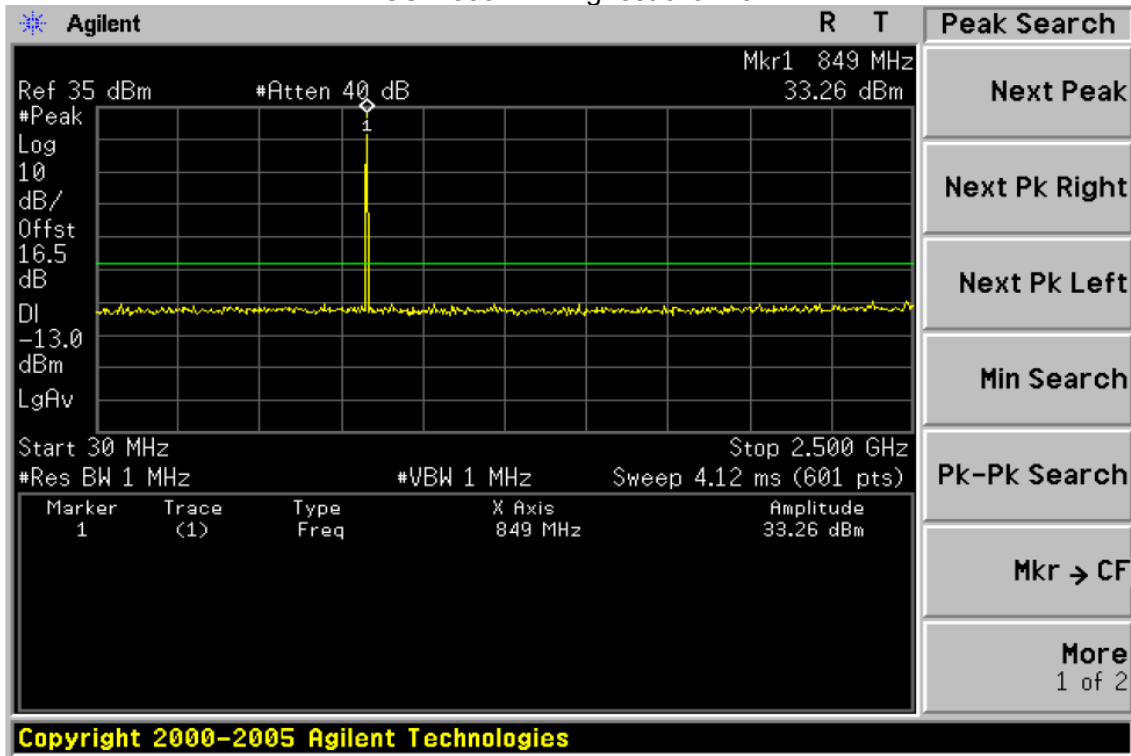



GSM 1900MHz Lowest channel

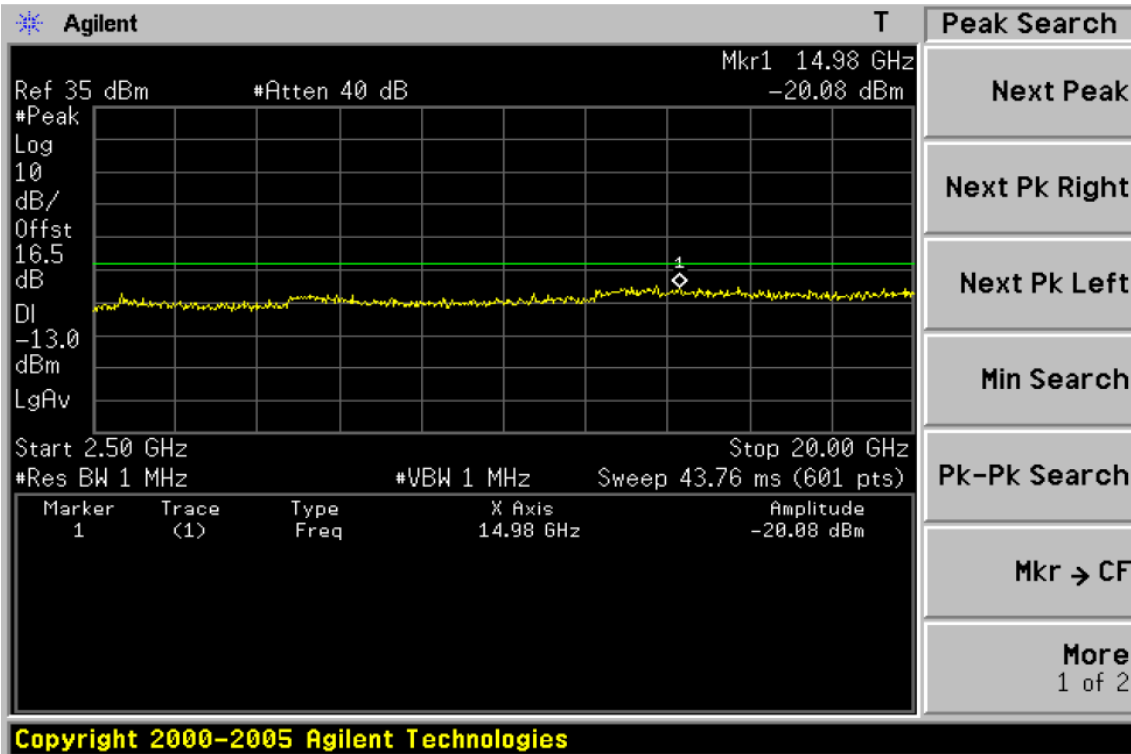
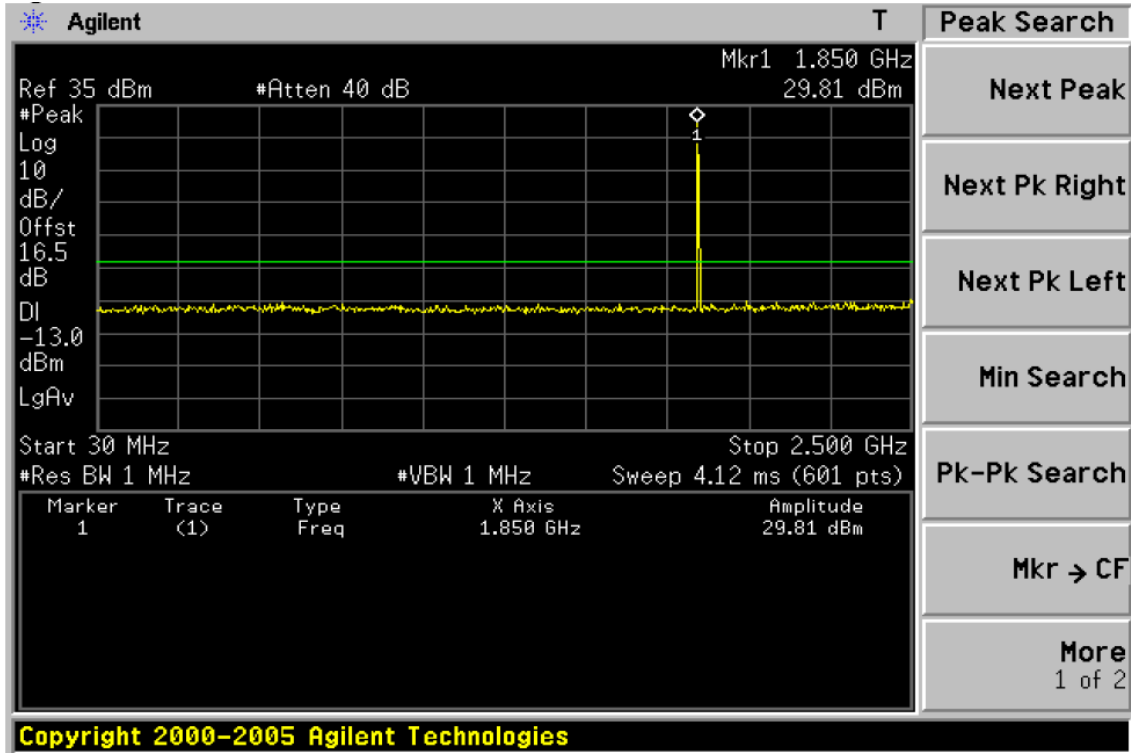



GSM 1900MHz Middle channel

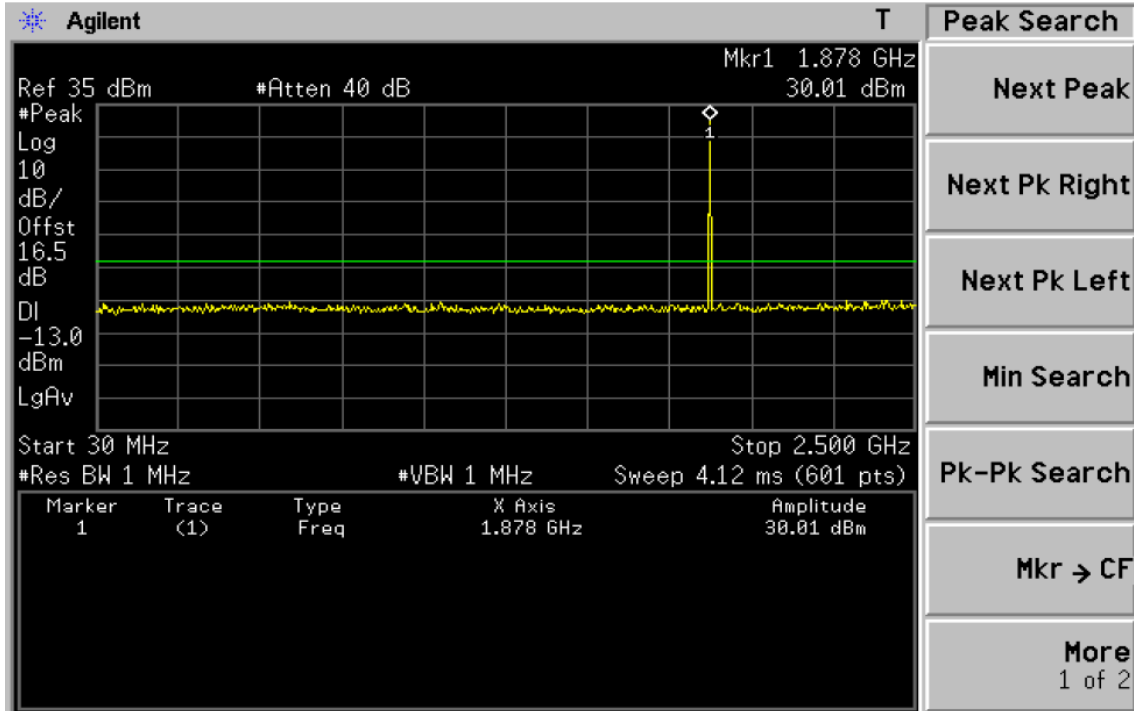

Copyright 2000-2005 Agilent Technologies

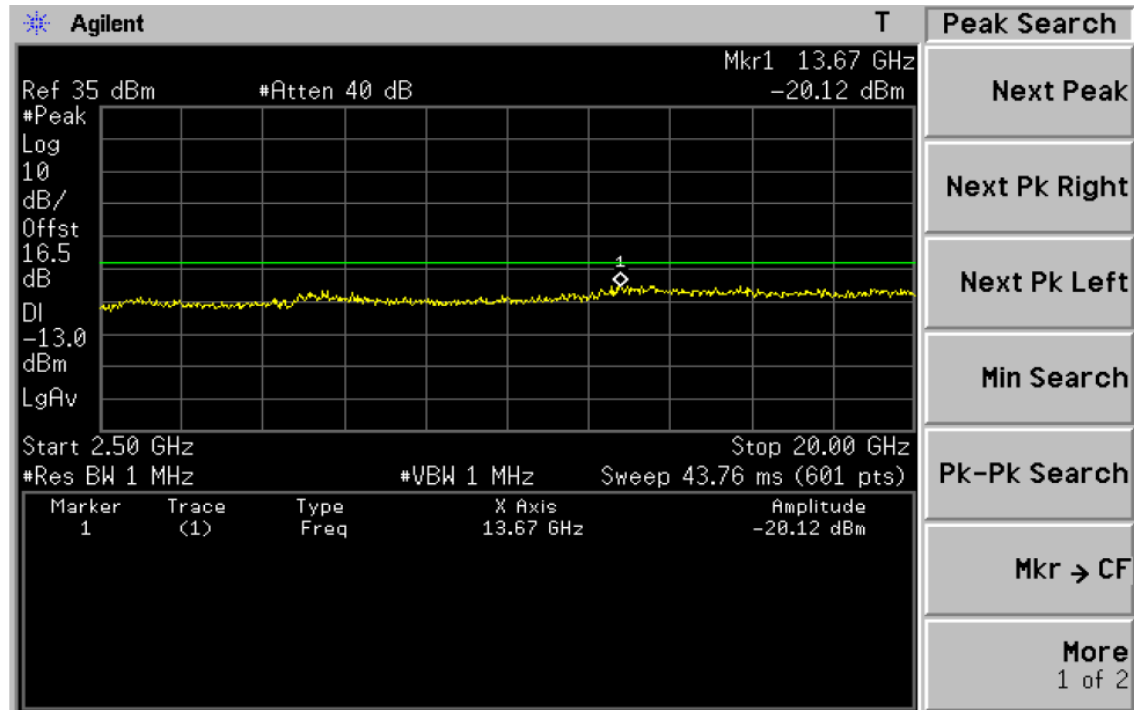

Copyright 2000-2005 Agilent Technologies



GSM 1900MHz Highest channel

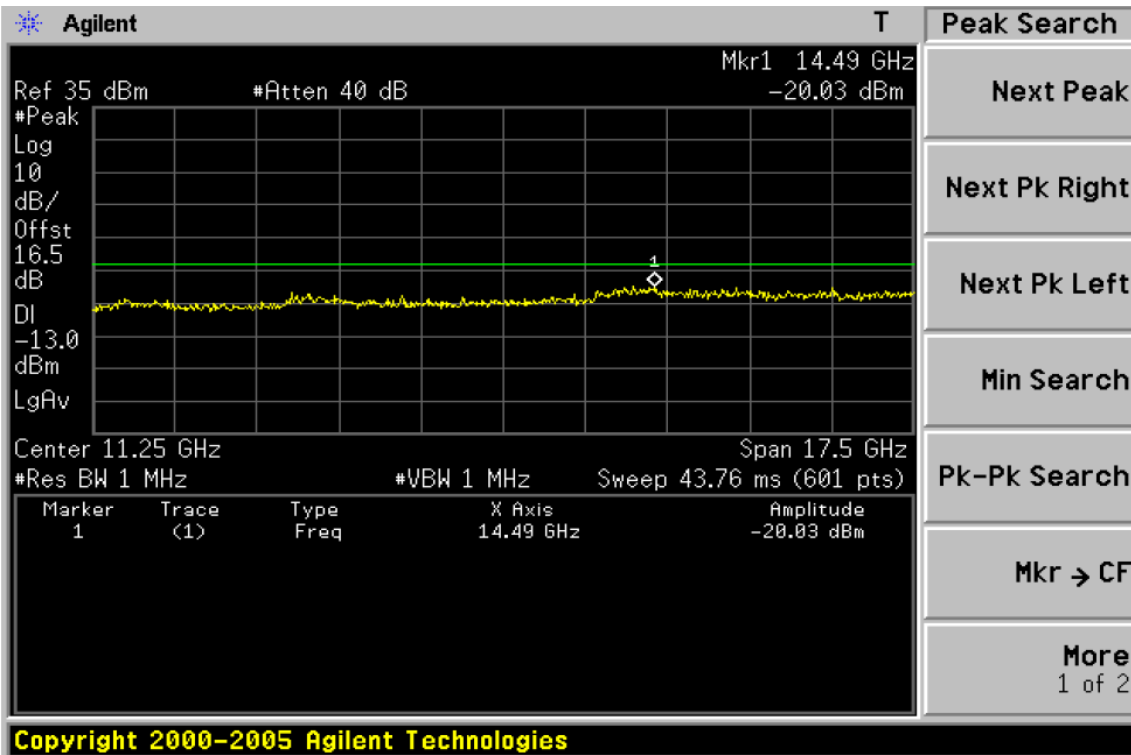
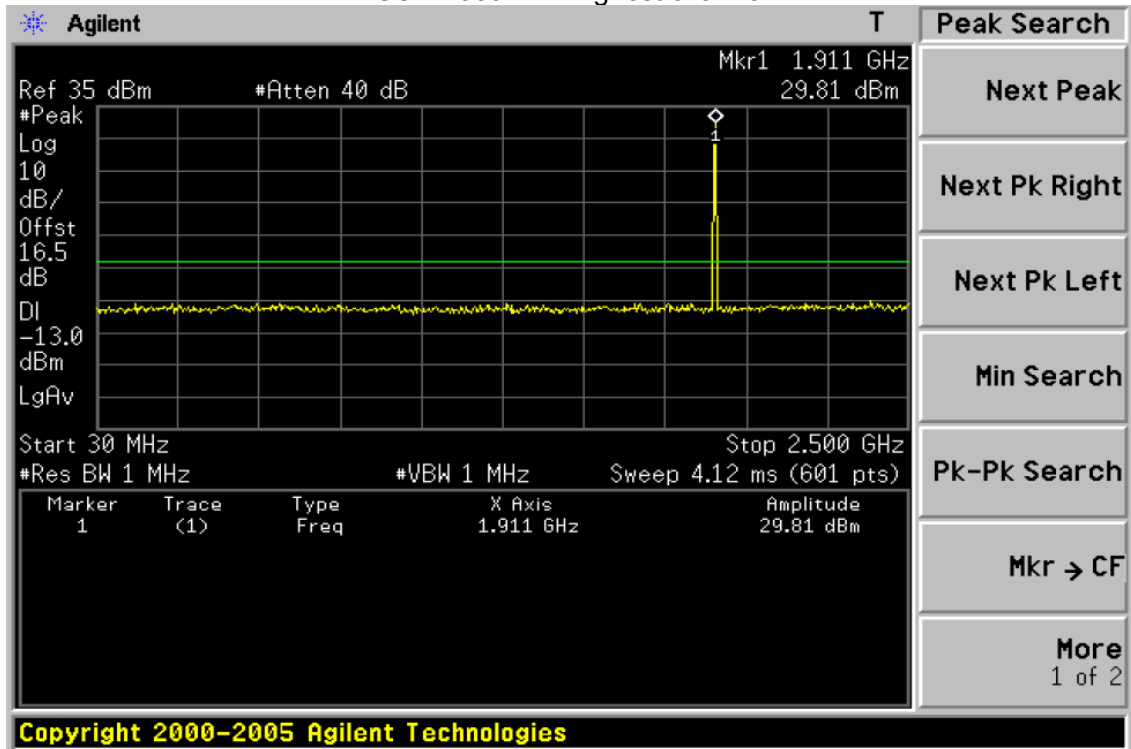

5.6. Conducted Out of Band Emissions

5.6.1. Limit

According to FCC section 22.917(b) and FCC section 24.238(b), 27.53(g)(h) in the 1MHz bands immediately outside and adjacent to the frequency block a resolution bandwidth of at least one percent of the emission bandwidth (26dB emission bandwidth) of the fundamental emission of the transmitter may be employed.

5.6.2. Test Setup

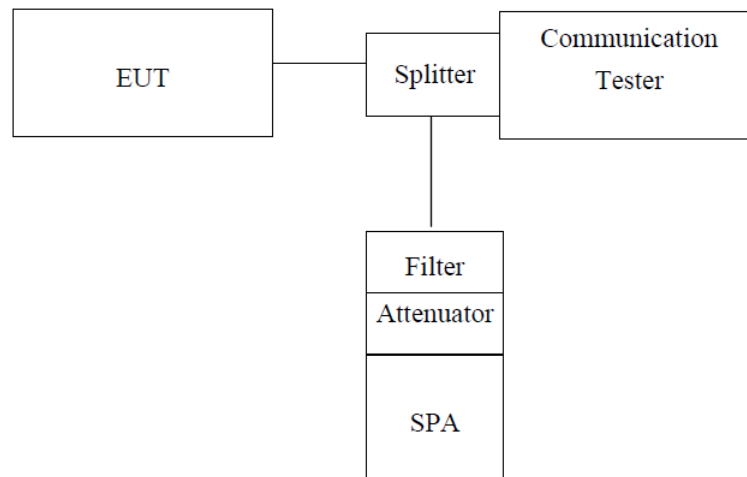

Note: Measurement setup for testing on Antenna connector

5.6.3. Measurement Procedure

The EUT, which is powered by the adapter, is coupled to the Spectrum Analyzer and the System Simulator with Attenuators through the Power Splitter; the RF load attached to the EUT antenna terminal is 50Ohm; the path loss as the factor is calibrated to correct the reading. The EUT is commanded by the System Simulator to operate at the maximum output power i.e. Power Control Level (PCL) = 5 and Power Class = 4. A call is established between the EUT and the System Simulator.

5.6.4. Test Result

The measurement frequency range is from 30MHz to the 10th harmonic of the fundamental frequency. The lowest, middle and highest channels are tested to verify the out of band emissions.

Test plot as follows:



GSM 850MHz Lowest channel

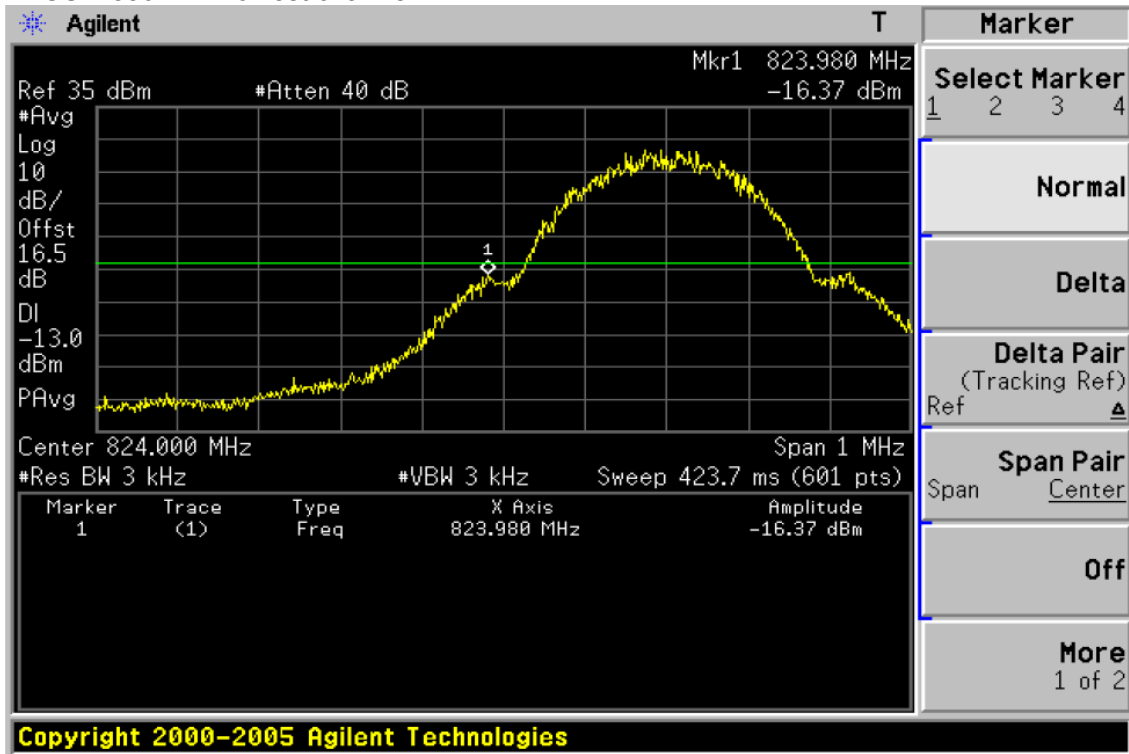

GSM 850MHz Highest channel

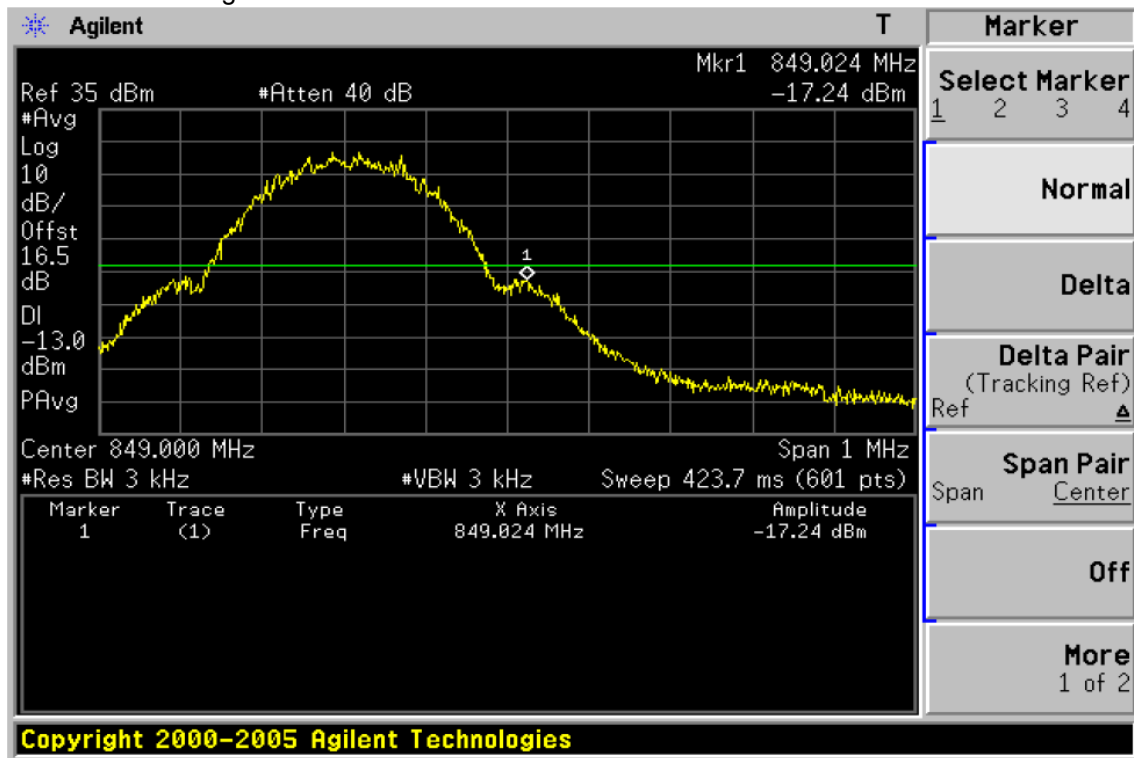



GSM 1900MHz Lowest channel

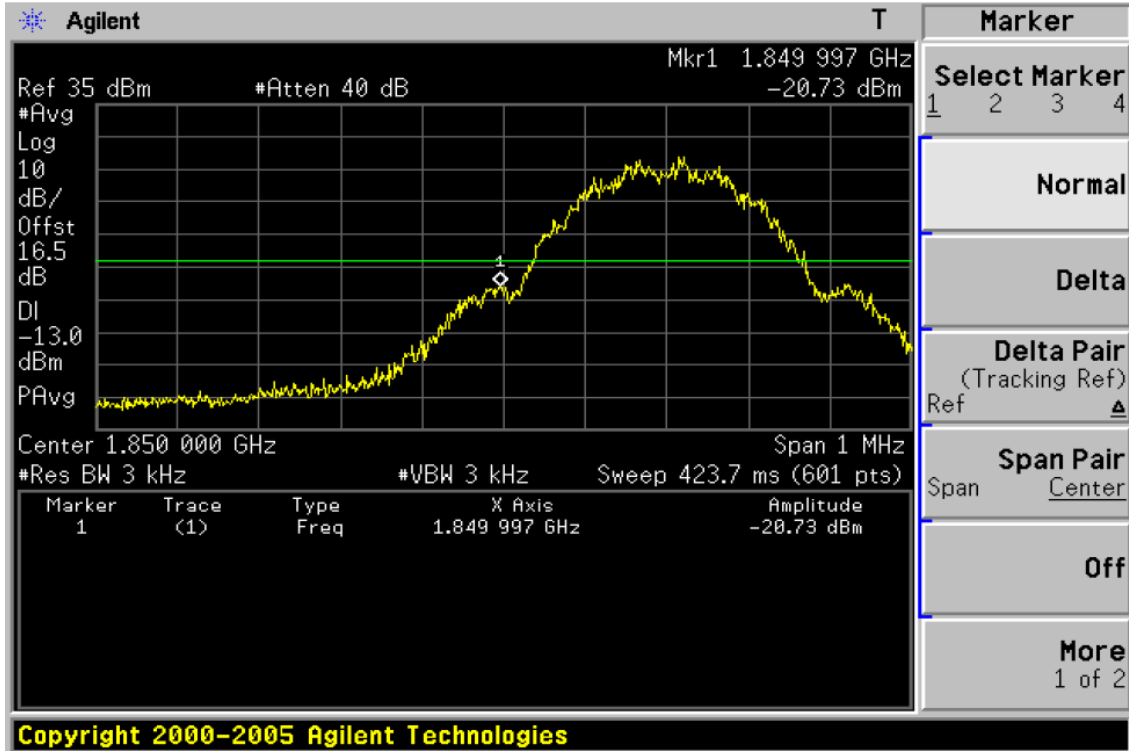

GSM 1900MHz Highest channel

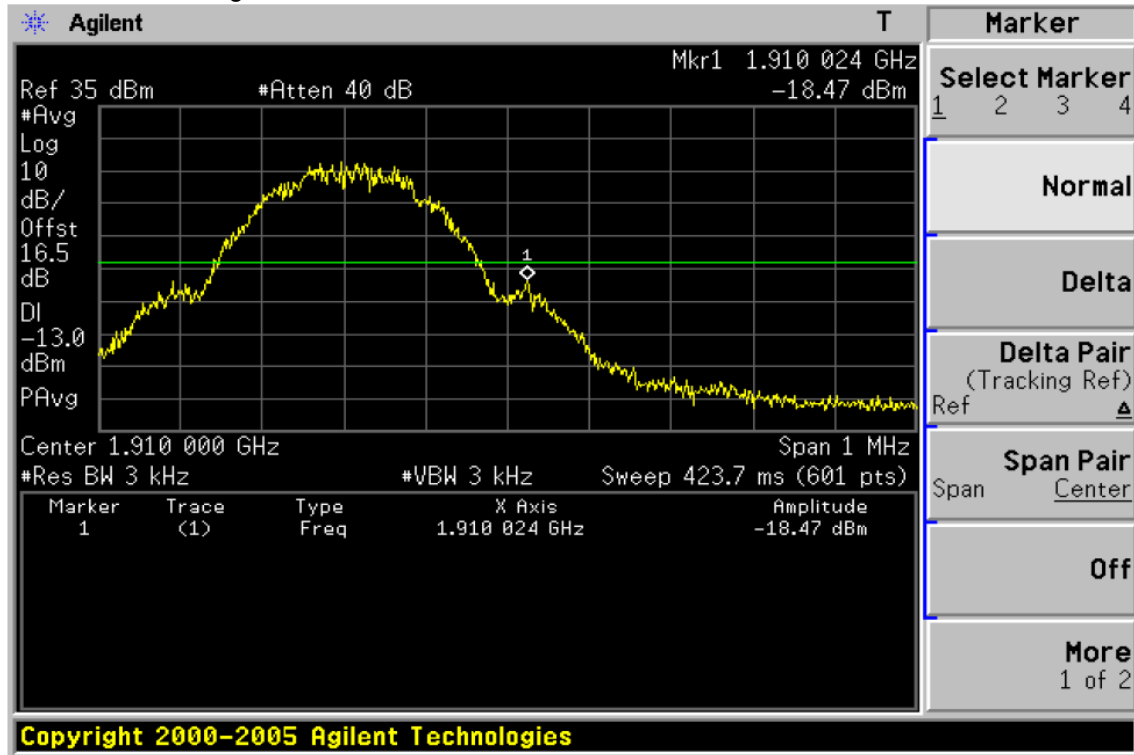

5.7. Transmitter Radiated Power (EIRP/ERP)

5.7.1. Limit

According to FCC section 22.913, the Effective Radiated Power (ERP) of mobile transmitters and auxiliary test transmitters must not exceed 7Watts, and FCC section 24.232, the broadband PCS mobile station is limited to 2 Watts e.i.r.p. peak power.

5.7.2. Test Setup

Below 1GHz

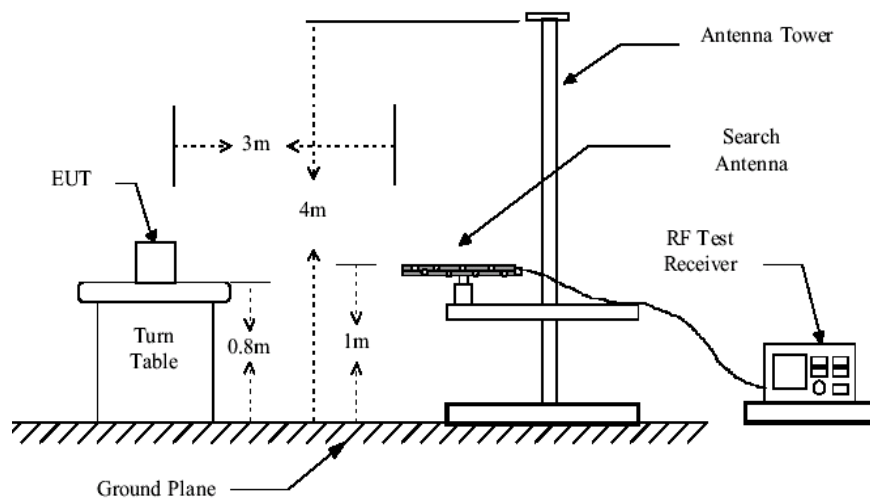

Above 1GHz

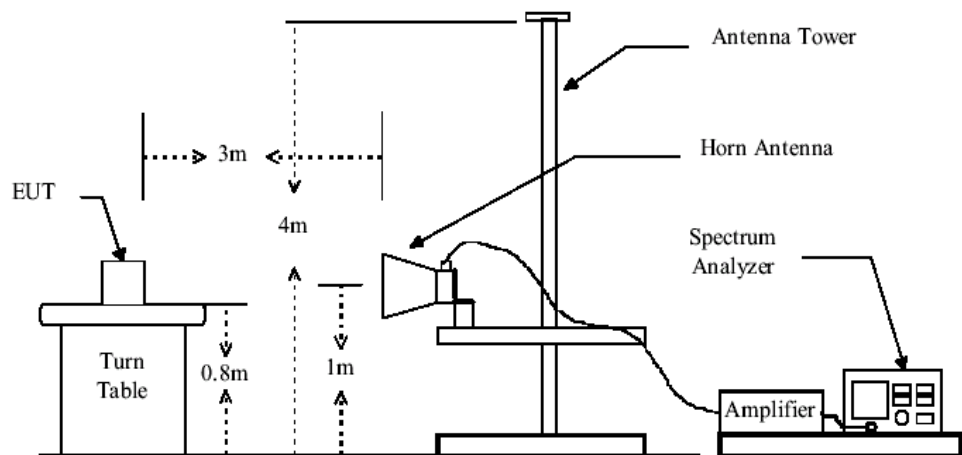

Substituted method:

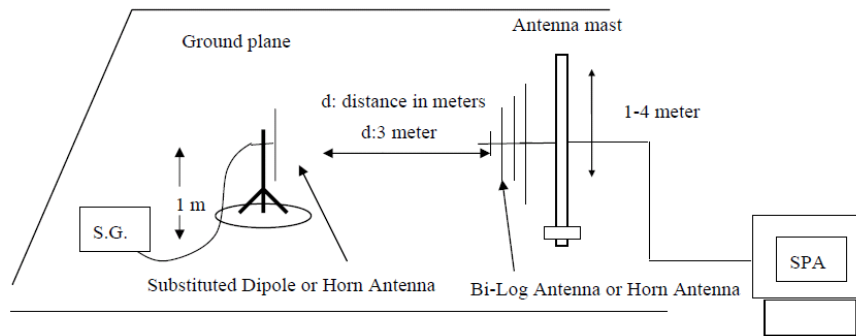

5.7.3. Measurement Procedure

The EUT was placed on a non-conductive turntable using a non-conductive support. The radiated emission at the fundamental frequency was measured at 3 m with a test antenna and EMI spectrum analyzer. All tests were conducted in a Full-Anechoic Chamber.

During the measurement, the EUT was in communication with the station. The highest emission was recorded with the rotation of the turntable and the lowering of the test antenna from 4m to 1m. The reading was recorded and the field strength (E in dBuV/m) was calculated.

ERP in frequency band 824.2 – 848.80.8MHz were measured using a substitution method. The EUT was replaced by a dipole antenna connected to the S.G. output was recorded and ERP was calculated as follows:

EIRP in frequency band 1850.2 – 1909.8MHz were measured using a substitution method. The EUT was replaced by a horn antenna connected to the S.G. output was recorded and EIRP was calculated as follows:

$$ERP = \text{S.G. output (dBm)} + \text{Antenna Gain (dBd)} - \text{Cable Loss (dB)}$$

$$EIRP = \text{S.G. output (dBm)} + \text{Antenna Gain (dBi)} - \text{Cable Loss (dB)}$$

Note: The EUT polarization means three polarizations, H means X polarization, E1 means Y polarization, E2 means Z polarization.

5.7.4. Test Result



EUT mode	Channel	EUT Pol.	Antenna Pol.	S.G. output (dBm)	Antenna Gain (dBd)	Cable Loss (dB)	ERP (dBm)	Limit (dBm)	Result
GSM850 (GSM link)	Lowest	H	V	29.15	3.68	1.65	31.18	38.45	Pass
			H	27.18	3.68	1.65	29.21		
		E1	V	23.08	3.68	1.65	25.11		
			H	27.13	3.68	1.65	29.16		
		E2	V	22.45	3.68	1.65	24.48		
			H	25.39	3.68	1.65	27.42		
	Middle	H	V	29.72	3.70	1.67	31.75	38.45	Pass
			H	27.58	3.70	1.67	29.61		
		E1	V	23.20	3.70	1.67	25.23		
			H	27.48	3.70	1.67	29.51		
		E2	V	23.76	3.70	1.67	25.79		
			H	26.54	3.70	1.67	28.57		
	Highest	H	V	30.38	3.70	1.71	32.37	38.45	Pass
			H	27.15	3.70	1.71	29.14		
		E1	V	23.15	3.70	1.71	25.14		
			H	26.59	3.70	1.71	28.58		
		E2	V	22.25	3.70	1.71	24.24		
			H	26.11	3.70	1.71	28.10		



EUT mode	Channel	EUT Pol.	Antenna Pol.	S.G. output (dBm)	Antenna Gain (dBi)	Cable Loss (dB)	ERP (dBm)	Limit (dBm)	Result
PCS1900 (GSM link)	Lowest	H	V	24.72	7.35	2.54	29.53	38.45	Pass
			H	22.78	7.35	2.54	27.59		
		E1	V	18.31	7.35	2.54	23.12		
			H	22.34	7.35	2.54	27.15		
		E2	V	17.71	7.35	2.54	22.52		
			H	20.84	7.35	2.54	25.65		
	Middle	H	V	25.65	7.51	2.62	30.54	38.45	Pass
			H	23.49	7.51	2.62	28.38		
		E1	V	19.85	7.51	2.62	24.74		
			H	24.59	7.51	2.62	29.48		
		E2	V	20.72	7.51	2.62	25.61		
			H	22.59	7.51	2.62	27.48		
	Highest	H	V	24.92	7.96	2.69	30.19	38.45	Pass
			H	21.86	7.96	2.69	27.13		
		E1	V	19.12	7.96	2.69	24.39		
			H	22.23	7.96	2.69	27.50		
		E2	V	17.00	7.96	2.69	22.27		
			H	24.69	7.96	2.69	29.96		

5.8. Radiated Out of Band Emissions

5.8.1. Limit

According to FCC section 22.917(a) and section 24.238(a), 27.53(g) the power of any emission outside of the authorized operating frequency ranges must be attenuated below the transmitting power

(P) by a factor of at least $43+10*\log(P)$ dB. This calculated to be -13dBm.

The spurious emission with frequency band 1900 according to FCC section 2.1057.

5.8.2. Test Setup

Below 1GHz

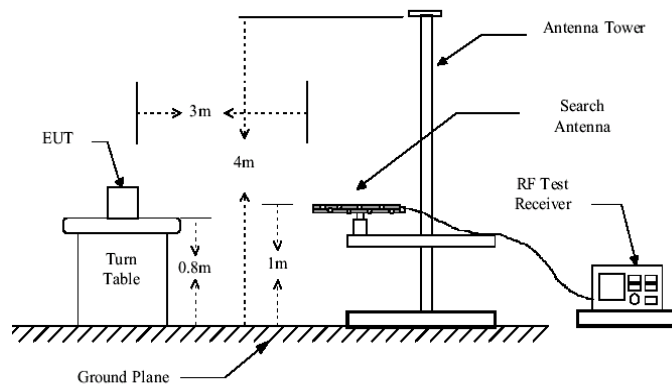

Above 1GHz

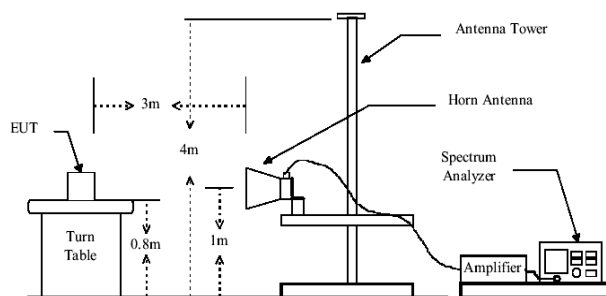

Substituted method:

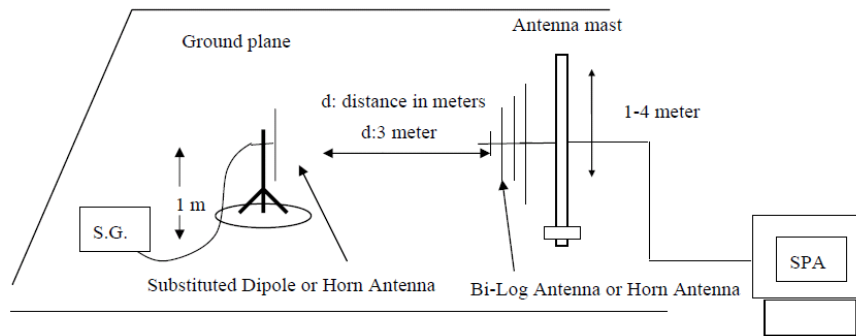

5.8.3. Measurement Procedure

The EUT was placed on a non-conductive, The measurement antenna was placed at a distance of 3 meters from the EUT. During the tests, the antenna height and the EUT azimuth were varied in order to identify the maximum level of emissions from the EUT. This maximization process was repeated with the EUT positioned in each of its three orthogonal orientations. all test in Full-Anechoic Chamber.

The frequency range up to tenth harmonic was investigated for each of three fundamental frequency (low, middle and high channels). Once spurious emission was identified, the power of the emission was determined using the substitution method.

The spurious emissions attenuation was calculated as the difference between radiated power at the fundamental frequency and the spurious emissions frequency.

$$EIRP = S.G. \text{ output (dBm)} + \text{Antenna Gain(dBi)} - \text{Cable Loss (dB)}$$

Note: Measurement Uncertainty: ±3.6 dB.



Band	Frequency (MHz)	Spurious Emission					Limit (dBm)	Result
		Polarization	S.G. output (dBm)	Antenna Gain (dBd)	Cable Loss (dB)	Level (dBm)		
GSM 850 Lowest	44.26	Vertical	-75.73	3.06	0.15	-72.82	-13	PASS
	1648.40	Vertical	-29.31	6.51	1.35	-24.15		
	2472.60	Vertical	-35.53	6.88	2.53	-31.18		
	3296.80	Vertical	-37.36	7.61	3.67	-33.42		
	4121.00	Vertical	-45.51	8.67	4.06	-40.90		
	4945.20	Vertical	-40.04	9.35	4.38	-35.07		
	99.86	Horizontal	-75.85	3.97	0.48	-72.36		
	2472.40	Horizontal	-34.06	6.88	1.35	-28.53		
	3296.80	Horizontal	-37.31	7.61	3.67	-33.37		
	4121.00	Horizontal	-45.95	8.67	4.06	-41.34		
	4945.20	Horizontal	-49.25	9.35	4.38	-44.28		
	5769.40	Horizontal	-43.47	9.94	4.87	-38.40		

Band	Frequency (MHz)	Spurious Emission					Limit (dBm)	Result
		Polarization	S.G. output (dBm)	Antenna Gain (dBd)	Cable Loss (dB)	Level (dBm)		
GSM 850 Middle	43.89	Vertical	-73.84	3.06	0.15	-70.93	-13	PASS
	1648.70	Vertical	-32.27	6.51	1.35	-27.11		
	2472.10	Vertical	-32.81	6.88	2.53	-28.46		
	3296.50	Vertical	-40.31	7.61	3.67	-36.37		
	4121.30	Vertical	-47.88	8.67	4.06	-43.27		
	4945.70	Vertical	-43.38	9.35	4.38	-38.41		
	99.59	Horizontal	-75.75	3.97	0.48	-72.26		
	2472.10	Horizontal	-29.59	6.88	1.35	-24.06		
	3296.20	Horizontal	-32.26	7.61	3.67	-28.32		
	4121.70	Horizontal	-48.56	8.67	4.06	-43.95		
	4945.00	Horizontal	-49.98	9.35	4.38	-45.01		
	5769.60	Horizontal	-39.96	9.94	4.87	-34.89		

Band	Frequency (MHz)	Spurious Emission					Limit (dBm)	Result
		Polarization	S.G. output (dBm)	Antenna Gain (dBd)	Cable Loss (dB)	Level (dBm)		
GSM 850 Highest	44.21	Vertical	-74.93	3.06	0.15	-72.02	-13	PASS
	1648.30	Vertical	-31.16	6.51	1.35	-26.00		
	2472.10	Vertical	-33.08	6.88	2.53	-28.73		
	3296.50	Vertical	-36.22	7.61	3.67	-32.28		
	4121.40	Vertical	-41.56	8.67	4.06	-36.95		
	4945.20	Vertical	-46.99	9.35	4.38	-42.02		
	100.27	Horizontal	-75.55	3.97	0.48	-72.06		
	2472.90	Horizontal	-29.98	6.88	1.35	-24.45		
	3296.30	Horizontal	-32.87	7.61	3.67	-28.93		
	4121.20	Horizontal	-38.60	8.67	4.06	-33.99		
	4945.70	Horizontal	-47.23	9.35	4.38	-42.26		
	5769.60	Horizontal	-53.49	9.94	4.87	-48.42		



Band	Frequency (MHz)	Spurious Emission					Limit (dBm)	Result
		Polarization	S.G. output (dBm)	Antenna Gain (dBi)	Cable Loss (dB)	Level (dBm)		
PCS1900 Lowest	62.26	Vertical	-75.96	2.42	0.29	-73.83	-13	PASS
	3700.40	Vertical	-46.35	7.76	3.75	-42.34		
	5550.60	Vertical	-47.47	9.84	4.94	-42.57		
	7400.80	Vertical	-39.88	10.21	5.32	-34.99		
	9251.00	Vertical	-43.27	11.36	6.02	-37.93		
	11101.20	Vertical	-44.81	14.52	6.68	-36.97		
	364.15	Horizontal	-76.60	5.38	0.74	-71.96		
	3700.40	Horizontal	-48.56	7.76	3.75	-44.55		
	5550.60	Horizontal	-47.84	9.84	4.94	-42.94		
	7400.80	Horizontal	-42.49	10.21	5.32	-37.60		
	9251.00	Horizontal	-47.73	11.36	6.02	-42.39		
11101.20	Horizontal	-47.51	14.52	6.68	-39.67			

Band	Frequency (MHz)	Spurious Emission					Limit (dBm)	Result
		Polarization	S.G. output (dBm)	Antenna Gain (dBi)	Cable Loss (dB)	Level (dBm)		
PCS1900 Middle	63.15	Vertical	-73.58	2.42	0.29	-71.45	-13	PASS
	3760.00	Vertical	-47.68	7.76	3.75	-43.67		
	5640.00	Vertical	-47.28	9.84	4.94	-42.38		
	7520.00	Vertical	-42.88	10.21	5.32	-37.99		
	9400.00	Vertical	-42.27	11.36	6.02	-36.93		
	11280.00	Vertical	-46.25	14.52	6.68	-38.41		
	363.97	Horizontal	-77.10	5.38	0.74	-72.46		
	3760.00	Horizontal	-46.10	7.76	3.75	-42.09		
	5640.00	Horizontal	-46.84	9.84	4.94	-41.94		
	7520.00	Horizontal	-39.48	10.21	5.32	-34.59		
	9400.00	Horizontal	-43.37	11.36	6.02	-38.03		
11280.00	Horizontal	-45.26	14.52	6.68	-37.42			

Band	Frequency (MHz)	Spurious Emission					Limit (dBm)	Result
		Polarization	S.G. output (dBm)	Antenna Gain (dBi)	Cable Loss (dB)	Level (dBm)		
PCS1900 Highest	63.06	Vertical	-74.13	2.42	0.29	-72.00	-13	PASS
	3819.60	Vertical	-47.30	7.79	3.53	-43.04		
	5729.40	Vertical	-41.74	9.88	5.02	-36.88		
	7639.20	Vertical	-37.91	10.25	5.54	-33.20		
	9549.00	Vertical	-44.80	11.38	6.16	-39.58		
	11458.80	Vertical	-47.25	14.56	6.72	-39.41		
	362.98	Horizontal	-76.16	5.38	0.74	-71.52		
	3819.60	Horizontal	-45.66	7.79	3.53	-41.40		
	5729.40	Horizontal	-41.64	9.88	5.02	-36.78		
	7639.20	Horizontal	-37.29	10.25	5.54	-32.58		
	9549.00	Horizontal	-42.89	11.38	6.16	-37.67		
11458.80	Horizontal	-44.80	14.56	6.72	-36.96			



5.9. CONDUCTED EMISSION MEASUREMENT

5.9.1. POWER LINE CONDUCTED EMISSION LIMITS (Frequency Range 150KHz-30MHz)

FREQUENCY (MHz)	Class A (dBuV)		Class B (dBuV)		Standard
	Quasi-peak	Average	Quas -peak	Average	
0.15 -0.5	79.00	66.00	66 - 56 *	56 - 46 *	CISPR
0.50 -5.0	73.00	60.00	56.00	46.00	CISPR
5.0 -30.0	73.00	60.00	60.00	50.00	CISPR

0.15 -0.5	79.00	66.00	66 - 56 *	56 - 46 *	FCC
0.50 -5.0	73.00	60.00	56.00	46.00	FCC
5.0 -30.0	73.00	60.00	60.00	50.00	FCC

Note:

- (1) The tighter limit applies at the band edges.
- (2) The limit of " * " marked band means the limitation decreases linearly with the logarithm of the frequency in the range.

The following table is the setting of the receiver

Receiver Parameters	Setting
Attenuation	10 dB
Start Frequency	0.15 MHz
Stop Frequency	30 MHz
IF Bandwidth	9 kHz

5.9.2. TEST PROCEDURE

The EUT was placed 0.8 meters from the horizontal ground plane with EUT being connected to the power mains through a line impedance stabilization network (LISN). All other support equipments powered from additional LISN(s). The LISN provide 50 Ohm/ 50uH of coupling impedance for the measuring instrument.

Interconnecting cables that hang closer than 40 cm to the ground plane shall be folded back and forth in the center forming a bundle 30 to 40 cm long.

I/O cables that are not connected to a peripheral shall be bundled in the center. The end of the cable may be terminated, if required, using the correct terminating impedance. The overall length shall not exceed 1 m.

LISN at least 80 cm from nearest part of EUT chassis.

For the actual test configuration, please refer to the related Item –EUT Test Photos.

5.9.3. DEVIATION FROM TEST STANDARD

No deviation

5.9.4. TEST SETUP

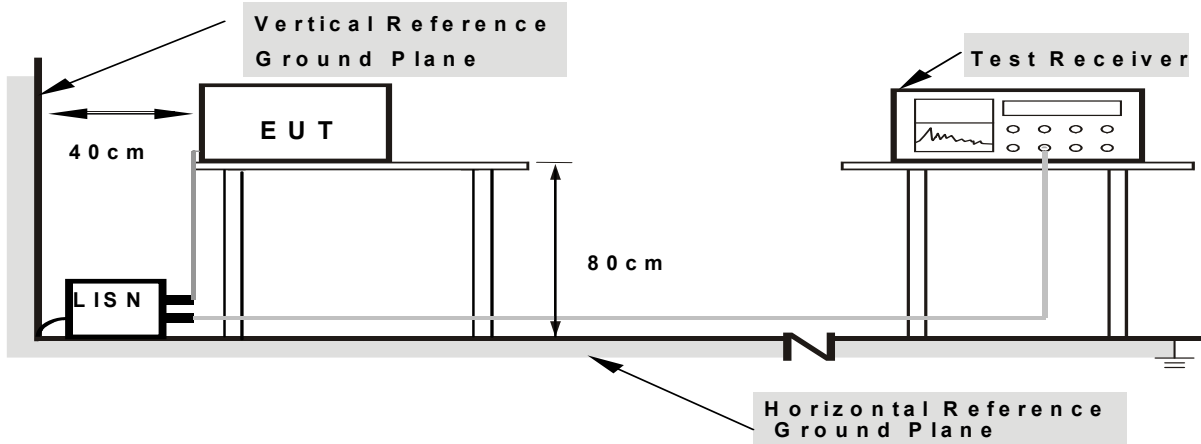

- Note: 1.Support units were connected to second LISN.
2.Both of LISNs (AMN) are 80 cm from EUT and at least 80 cm from other units and other metal planes

5.9.5. EUT OPERATING CONDITIONS

The EUT was configured for testing in a typical fashion (as a customer would normally use it). The EUT has been programmed to continuously transmit during test. This operating condition was tested and used to collect the included data.

We pretest AC 120V and AC 240V, the worst voltage was AC 120V and the data recording in the report.



5.9.6. TEST RESULTS

EUT :	Mobile Phone	Model Name. :	ST88A
Temperature :	26°C	Relative Humidity :	54%
Pressure :	1010hPa	Phase :	L
Test Voltage :	AC120V/60Hz	Test Mode :	Link Mode

No.	Mk.	Freq.	Reading Level	Correct Factor	Measurement	Limit	Over	Detector	Comment
		MHz	dBuV	dB	dBuV	dBuV	dB		
1	*	0.1500	49.27	10.05	59.32	65.99	-6.67	QP	
2		0.1500	30.10	10.05	40.15	55.99	-15.84	AVG	
3		0.3700	38.49	10.10	48.59	58.50	-9.91	QP	
4		0.3700	22.22	10.10	32.32	48.50	-16.18	AVG	
5		1.1460	33.58	10.17	43.75	56.00	-12.25	QP	
6		1.1460	18.44	10.17	28.61	46.00	-17.39	AVG	
7		2.6420	33.67	10.19	43.86	56.00	-12.14	QP	
8		2.6420	16.96	10.19	27.15	46.00	-18.85	AVG	
9		4.3780	33.22	10.16	43.38	56.00	-12.62	QP	
10		4.3780	17.17	10.16	27.33	46.00	-18.67	AVG	
11		9.9100	29.90	10.12	40.02	60.00	-19.98	QP	
12		9.9100	13.24	10.12	23.36	50.00	-26.64	AVG	

Remark:

1. All readings are Quasi-Peak and Average values.
2. Factor = Insertion Loss + Cable Loss.

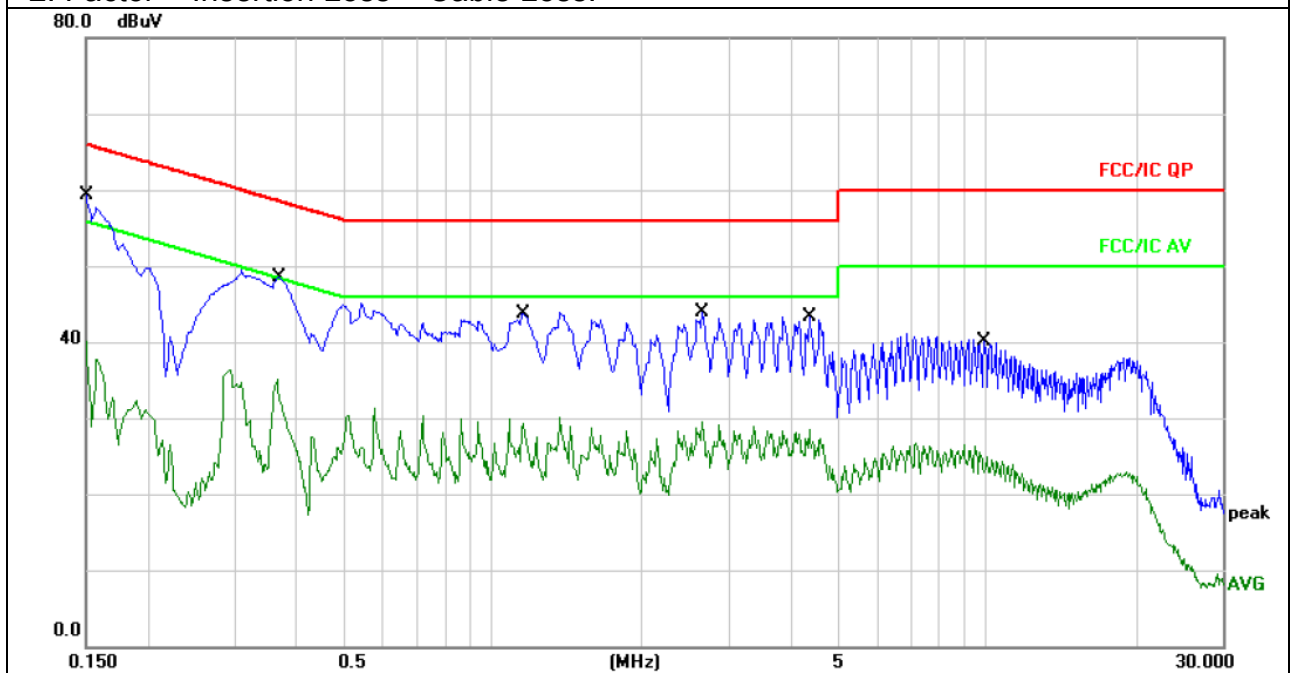



EUT :	Mobile Phone	Model Name. :	ST88A
Temperature :	26°C	Relative Humidity :	54%
Pressure :	1010hPa	Phase :	N
Test Voltage :	AC120V/60Hz	Test Mode :	Link Mode

No.	Mk.	Freq.	Reading Level	Correct Factor	Measurement	Limit	Over	Detector	Comment
		MHz	dBuV	dB	dBuV	dBuV	dB		
1	*	0.1500	46.86	10.05	56.91	65.99	-9.08	QP	
2		0.1500	34.43	10.05	44.48	55.99	-11.51	AVG	
3		0.3100	37.94	10.09	48.03	59.97	-11.94	QP	
4		0.3100	20.60	10.09	30.69	49.97	-19.28	AVG	
5		0.7260	32.38	10.14	42.52	56.00	-13.48	QP	
6		0.7260	12.54	10.14	22.68	46.00	-23.32	AVG	
7		2.1340	32.81	10.18	42.99	56.00	-13.01	QP	
8		2.1340	16.42	10.18	26.60	46.00	-19.40	AVG	
9		4.3820	34.78	10.16	44.94	56.00	-11.06	QP	
10		4.3820	19.08	10.16	29.24	46.00	-16.76	AVG	
11		9.9100	30.82	10.12	40.94	60.00	-19.06	QP	
12		9.9100	15.38	10.12	25.50	50.00	-24.50	AVG	

Remark:

1. All readings are Quasi-Peak and Average values.
2. Factor = Insertion Loss + Cable Loss.

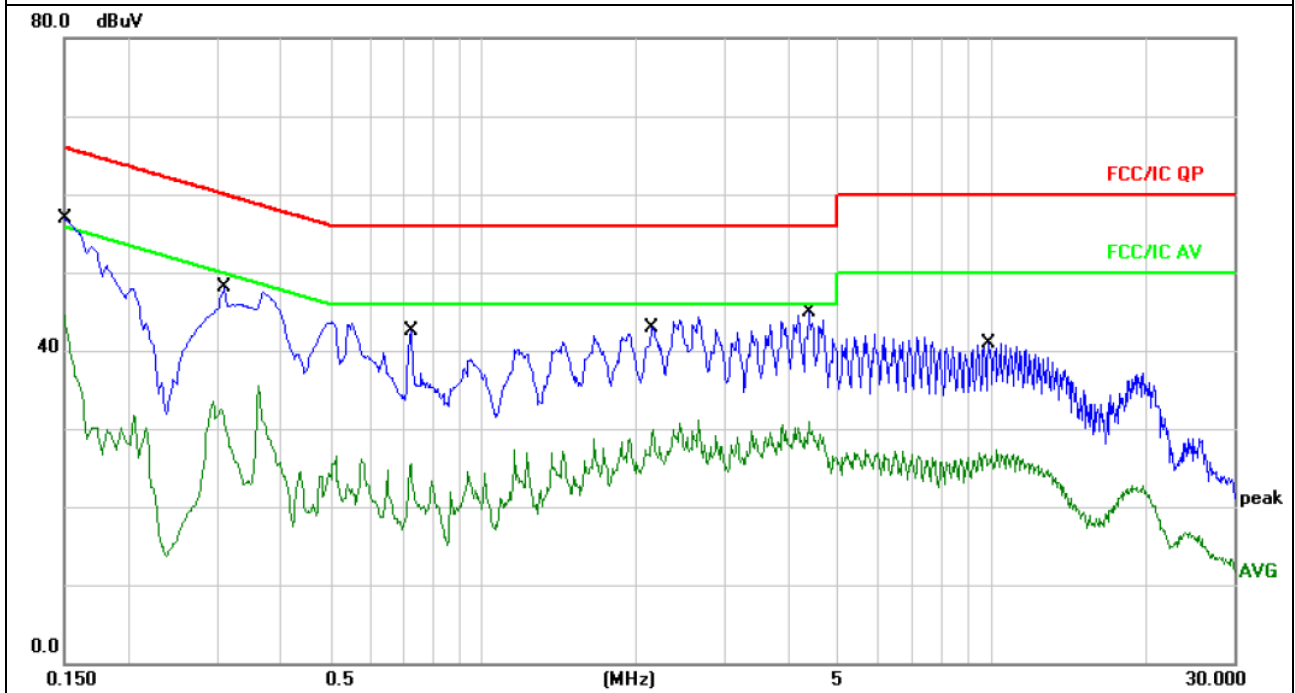

6. PHOTOGRAPHS OF TEST SET-UP

RE

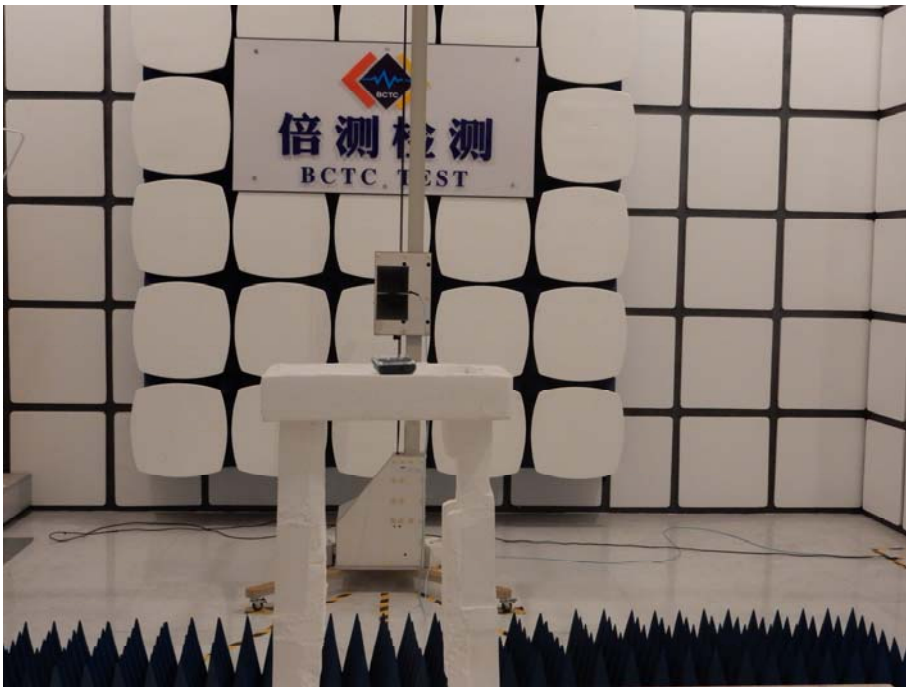
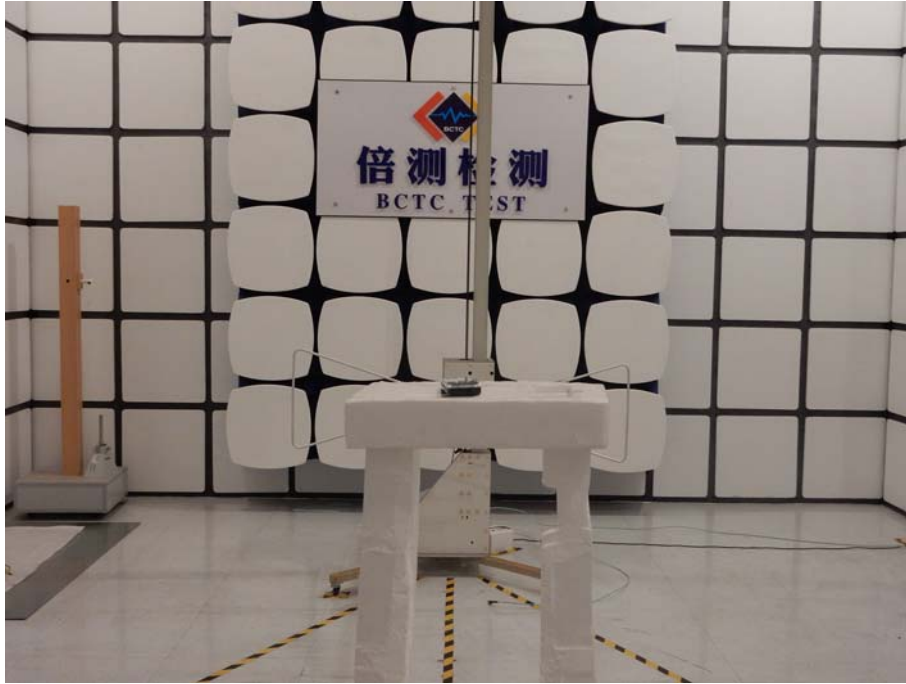

CE



7. PHOTOGRAPHS OF THE EUT





