

FCC Test Report

(For 5.18 ~ 5.24GHz, 5.745 ~ 5.825GHz)

Report No.: RF170508C09-1

FCC ID: 2AG6R-AN700APOAC

Test Model: AN-700-AP-O-AC

Received Date: May 08, 2017

Test Date: May 27 ~ Jun. 02, 2017

Issued Date: Jun. 23, 2017

Applicant: Araknis Networks

Address: 1800 Continental Blvd. Ste 200, Charlotte, North Carolina, United States
28273

Issued By: Bureau Veritas Consumer Products Services (H.K.) Ltd., Taoyuan Branch

Lab Address: No. 47-2, 14th Ling, Chia Pau Vil., Lin Kou Dist., New Taipei City, Taiwan,
R.O.C.

Test Location: No. 19, Hwa Ya 2nd Rd., Wen Hwa Vil., Kwei Shan Dist., Taoyuan City
33383, TAIWAN (R.O.C.)



This report is for your exclusive use. Any copying or replication of this report to or for any other person or entity, or use of our name or trademark, is permitted only with our prior written permission. This report sets forth our findings solely with respect to the test samples identified herein. The results set forth in this report are not indicative or representative of the quality or characteristics of the lot from which a test sample was taken or any similar or identical product unless specifically and expressly noted. Our report includes all of the tests requested by you and the results thereof based upon the information that you provided to us. You have 60 days from date of issuance of this report to notify us of any material error or omission caused by our negligence, provided, however, that such notice shall be in writing and shall specifically address the issue you wish to raise. A failure to raise such issue within the prescribed time shall constitute your unqualified acceptance of the completeness of this report, the tests conducted and the correctness of the report contents. Unless specific mention, the uncertainty of measurement has been explicitly taken into account to declare the compliance or non-compliance to the specification. The report must not be used by the client to claim product certification, approval, or endorsement by TAF or any government agencies.

Table of Contents

Release Control Record	4
1 Certificate of Conformity	5
2 Summary of Test Results	6
2.1 Measurement Uncertainty.....	6
2.2 Modification Record.....	6
3 General Information	7
3.1 General Description of EUT.....	7
3.2 Description of Test Modes.....	9
3.2.1 Test Mode Applicability and Tested Channel Detail.....	10
3.3 Duty Cycle of Test Signal.....	12
3.4 Description of Support Units.....	13
3.4.1 Configuration of System under Test.....	13
3.5 General Description of Applied Standard.....	14
4 Test Types and Results	15
4.1 Radiated Emission and Bandedge Measurement.....	15
4.1.1 Limits of Radiated Emission and Bandedge Measurement.....	15
4.1.2 Test Instruments.....	16
4.1.3 Test Procedure.....	17
4.1.4 Deviation from Test Standard.....	17
4.1.5 Test Setup.....	18
4.1.6 EUT Operating Conditions.....	19
4.1.7 Test Results.....	20
4.2 Conducted Emission Measurement.....	39
4.2.1 Limits of Conducted Emission Measurement.....	39
4.2.2 Test Instruments.....	39
4.2.3 Test Procedure.....	40
4.2.4 Deviation from Test Standard.....	40
4.2.5 Test Setup.....	40
4.2.6 EUT Operating Conditions.....	40
4.2.7 Test Results.....	41
4.3 Transmit Power Measurement.....	43
4.3.1 Limits of Transmit Power Measurement.....	43
4.3.2 Test Setup.....	43
4.3.3 Test Instruments.....	43
4.3.4 Test Procedure.....	44
4.3.5 Deviation from Test Standard.....	44
4.3.6 EUT Operating Conditions.....	44
4.3.7 Test Result.....	45
4.4 Occupied Bandwidth Measurement.....	49
4.4.1 Test Setup.....	49
4.4.2 Test Instruments.....	49
4.4.3 Test Procedure.....	49
4.4.4 Test Results.....	50
4.5 Peak Power Spectral Density Measurement.....	52
4.5.1 Limits of Peak Power Spectral Density Measurement.....	52
4.5.2 Test Setup.....	52
4.5.3 Test Instruments.....	52
4.5.4 Test Procedure.....	53
4.5.5 Deviation from Test Standard.....	53
4.5.6 EUT Operating Condition.....	53
4.5.7 Test Results.....	54
4.6 Frequency Stability.....	61
4.6.1 Limits of Frequency Stability Measurement.....	61

4.6.2	Test Setup.....	61
4.6.3	Test Instruments	61
4.6.4	Test Procedure	61
4.6.5	Deviation from Test Standard	61
4.6.6	EUT Operating Condition	61
4.6.7	Test Results	62
4.7	6dB Bandwidth Measurement.....	63
4.7.1	Limits of 6dB Bandwidth Measurement.....	63
4.7.2	Test Setup.....	63
4.7.3	Test Instruments	63
4.7.4	Test Procedure	63
4.7.5	Deviation from Test Standard	63
4.7.6	EUT Operating Condition	63
4.7.7	Test Results	64
5	Pictures of Test Arrangements.....	66
	Annex A- Radiated Out of Band Emission (OOBE) Measurement (For U-NII-3 band).....	67
	Appendix – Information on the Testing Laboratories	70

Release Control Record

Issue No.	Description	Date Issued
RF170508C09-1	Original release.	Jun. 23, 2017

1 Certificate of Conformity

Product: Araknis Networks Dual-Band Wireless-AC 1750 Outdoor Access Point

Brand: Araknis Networks

Test Model: AN-700-AP-O-AC

Sample Status: Engineering sample

Applicant: Araknis Networks

Test Date: May 27 ~ Jun. 02, 2017

Standard: 47 CFR FCC Part 15, Subpart E (Section 15.407)
ANSI C63.10:2013

The above equipment has been tested by **Bureau Veritas Consumer Products Services (H.K.) Ltd., Taoyuan Branch**, and found compliance with the requirement of the above standards. The test record, data evaluation & Equipment Under Test (EUT) configurations represented herein are true and accurate accounts of the measurements of the sample's EMC characteristics under the Conditions specified in this report.

Prepared by :  , **Date:** Jun. 23, 2017
Pettie Chen / Senior Specialist

Approved by :  , **Date:** Jun. 23, 2017
Ken Liu / Senior Manager

2 Summary of Test Results

47 CFR FCC Part 15, Subpart E (Section 15.407)			
FCC Clause	Test Item	Result	Remarks
15.407(b)(6)	AC Power Conducted Emissions	Pass	Meet the requirement of limit. Minimum passing margin is -7.53dB at 0.47060MHz.
15.407(b) (1/2/3/4(i/ii)/6)	Radiated Emissions & Band Edge Measurement*	Pass	Meet the requirement of limit. Minimum passing margin is -1.8dB at 5650.00MHz.
15.407(a)(1/2/3)	Max Average Transmit Power	Pass	Meet the requirement of limit.
15.407(a)(1/2/3)	Peak Power Spectral Density	Pass	Meet the requirement of limit.
15.407(e)	6dB bandwidth	Pass	Meet the requirement of limit. (U-NII-3 Band only)
15.407(g)	Frequency Stability	Pass	Meet the requirement of limit.
15.203	Antenna Requirement	Pass	Antenna connector is IPEX not a standard connector.

*For U-NII-3 band compliance with rule part 15.407(b)(i), the OOB test plots were recorded in Annex A.

2.1 Measurement Uncertainty

Where relevant, the following measurement uncertainty levels have been estimated for tests performed on the EUT as specified in CISPR 16-4-2:

Measurement	Frequency	Expanded Uncertainty (k=2) (\pm)
Conducted Emissions at mains ports	150kHz ~ 30MHz	2.94 dB
Radiated Emissions up to 1 GHz	30MHz ~ 200MHz	3.86 dB
	200MHz ~ 1000MHz	3.87 dB
Radiated Emissions above 1 GHz	1GHz ~ 18GHz	2.29 dB
	18GHz ~ 40GHz	2.29 dB

2.2 Modification Record

There were no modifications required for compliance.

3 General Information

3.1 General Description of EUT

Product	Araknis Networks Dual-Band Wireless-AC 1750 Outdoor Access Point
Brand	Araknis Networks
Test Model	AN-700-AP-O-AC
Status of EUT	Engineering sample
Power Supply Rating	54Vdc (PoE)
Modulation Type	256QAM, 64QAM, 16QAM, QPSK, BPSK
Modulation Technology	OFDM
Transfer Rate	802.11a: 54.0/ 48.0/ 36.0/ 24.0/ 18.0/ 12.0/ 9.0/ 6.0Mbps 802.11n: up to 450.0Mbps 802.11ac: up to 1300.0Mbps
Operating Frequency	5180 ~ 5240MHz & 5745 ~ 5825MHz
Number of Channel	5180 ~ 5240MHz: 4 for 802.11a, 802.11n (HT20), 802.11ac (VHT20) 2 for 802.11n (HT40), 802.11ac (VHT40) 1 for 802.11ac (VHT80) 5745 ~ 5825MHz: 5 for 802.11a, 802.11n (HT20), 802.11ac (VHT20) 2 for 802.11n (HT40), 802.11ac (VHT40) 1 for 802.11ac (VHT80)
Output Power	5180 ~ 5240MHz: 33.596mW 5745 ~ 5825MHz: 680.720mW
Antenna Type	Refer to Note
Antenna Connector	Refer to Note
Accessory Device	NA
Data Cable Supplied	NA

Note:

- The EUT incorporates a MIMO function. Physically, the EUT provides 3 completed transmitters and 3 receivers.

Modulation Mode	TX Function
802.11a	3TX
802.11n (HT20)	3TX
802.11n (HT40)	3TX
802.11ac (VHT20)	3TX
802.11ac (VHT40)	3TX
802.11ac (VHT80)	3TX

*The modulation and bandwidth are similar for 802.11n mode for 20MHz/40MHz and 802.11ac mode for 20MHz/40MHz, therefore investigated worst case to representative mode in test report. (Final test mode refer section 3.2.1)

2. The EUT consumes power from the following PoE. (Support unit only)

Brand	EnGenius
Model	EAP5006GP
Input Power	100-240Vac~10.8A, 50-60Hz
Output Power	54Vdc, 0.6A
Power Line	0.5m non-shielded power cable without core

3. The EUT with follow antennas gain is listed as table below.

Ant. Type	Dipole							
Connector	IPEX							
Frequency (MHz)	2400		2450		2500			
Ant. 1	3.54		3.34		2.99			
Ant. 2	4.96		5.02		4.90			
Ant. 3	3.55		3.01		3.17			
Frequency (MHz)	5150	5250	5350	5450	5550	5650	5750	5850
Ant. 4	4.54	5.28	5.57	5.51	4.56	4.44	4.48	4.85
Ant. 5	5.46	5.65	6.12	5.57	5.83	5.13	5.02	5.82
Ant. 6	4.98	5.70	6.26	5.98	4.27	4.20	4.46	4.38

4. 2.4GHz, 5GHz technology can transmit at same time.

5. The EUT will install at outdoor area, the highest antenna gain as below, for more detail information please refer to antenna specification and user manual

Antenna Model	Antenna gain	Antenna install degree
EWS660AP	5.7dBi	

Due to device will installation position by user, thus consider the highest antenna gain are chosen from antenna specification exhibits from 0 to 360 degrees for U-NII-1 band

6. Spurious emission of the simultaneous operation (2.4GHz and 5GHz) has been evaluated and no non-compliance was found.

7. The above EUT information is declared by manufacturer and for more detailed features description, please refer to the manufacturer's specifications or user's manual.

3.2 Description of Test Modes

FOR 5180 ~ 5240MHz

4 channels are provided for 802.11a, 802.11n (HT20), 802.11ac (VHT20):

Channel	Frequency	Channel	Frequency
36	5180 MHz	44	5220 MHz
40	5200 MHz	48	5240 MHz

2 channels are provided for 802.11n (HT40), 802.11ac (40MHz):

Channel	Frequency	Channel	Frequency
38	5190 MHz	46	5230 MHz

1 channel is provided for 802.11ac (VHT80):

Channel	Frequency
42	5210MHz

FOR 5745 ~ 5825MHz:

5 channels are provided for 802.11a, 802.11n (HT20), 802.11ac (VHT20):

Channel	Frequency	Channel	Frequency
149	5745MHz	161	5805MHz
153	5765MHz	165	5825MHz
157	5785MHz		

2 channels are provided for 802.11n (HT40), 802.11ac (VHT40):

Channel	Frequency	Channel	Frequency
151	5755MHz	159	5795MHz

1 channel is provided for 802.11ac (VHT80):

Channel	Frequency
155	5775MHz

3.2.1 Test Mode Applicability and Tested Channel Detail

EUT CONFIGURE MODE	APPLICABLE TO				DESCRIPTION
	RE≥1G	RE<1G	PLC	APCM	
-	√	√	√	√	-

Where **RE≥1G**: Radiated Emission above 1GHz **RE<1G**: Radiated Emission below 1GHz
PLC: Power Line Conducted Emission **APCM**: Antenna Port Conducted Measurement

Note: The EUT had been pre-tested on the positioned of each 3 axis. The worst case was found when positioned on **Z-plane**.

Radiated Emission Test (Above 1GHz):

- Pre-Scan has been conducted to determine the worst-case mode from all possible combinations between available modulations, data rates and antenna ports (if EUT with antenna diversity architecture).
- Following channel(s) was (were) selected for the final test as listed below.

EUT CONFIGURE MODE	MODE	FREQ. BAND (MHz)	AVAILABLE CHANNEL	TESTED CHANNEL	MODULATION TECHNOLOGY	MODULATION TYPE	DATA RATE (Mbps)
-	802.11a	5180-5240	36 to 48	36, 40, 48	OFDM	BPSK	6.0
-	802.11n (HT20)		36 to 48	36, 40, 48	OFDM	BPSK	6.5
-	802.11n (HT40)		38 to 46	38, 46	OFDM	BPSK	13.5
-	802.11ac (VHT80)		42	42	OFDM	BPSK	97.5
-	802.11a	5745-5825	149 to 165	149, 157, 165	OFDM	BPSK	6.0
-	802.11n (HT20)		149 to 165	149, 157, 165	OFDM	BPSK	6.5
-	802.11n (HT40)		151 to 159	151, 159	OFDM	BPSK	13.5
-	802.11ac (VHT80)		155	155	OFDM	BPSK	97.5

Radiated Emission Test (Below 1GHz):

- Pre-Scan has been conducted to determine the worst-case mode from all possible combinations between available modulations, data rates and antenna ports (if EUT with antenna diversity architecture).
- Following channel(s) was (were) selected for the final test as listed below.

EUT CONFIGURE MODE	MODE	FREQ. BAND (MHz)	AVAILABLE CHANNEL	TESTED CHANNEL	MODULATION TECHNOLOGY	MODULATION TYPE	DATA RATE (Mbps)
-	802.11a	5180-5320 5745-5825	36 to 64 149 to 165	157	OFDM	BPSK	6.0

Power Line Conducted Emission Test:

- Pre-Scan has been conducted to determine the worst-case mode from all possible combinations between available modulations, data rates and antenna ports (if EUT with antenna diversity architecture).
- Following channel(s) was (were) selected for the final test as listed below.

EUT CONFIGURE MODE	MODE	FREQ. BAND (MHz)	AVAILABLE CHANNEL	TESTED CHANNEL	MODULATION TECHNOLOGY	MODULATION TYPE	DATA RATE (Mbps)
-	802.11a	5180-5320 5745-5825	36 to 64 149 to 165	157	OFDM	BPSK	6.0

Antenna Port Conducted Measurement:

- This item includes all test value of each mode, but only includes spectrum plot of worst value of each mode.
- Pre-Scan has been conducted to determine the worst-case mode from all possible combinations between available modulations, data rates and antenna ports (if EUT with antenna diversity architecture).
- Following channel(s) was (were) selected for the final test as listed below.

EUT CONFIGURE MODE	MODE	FREQ. BAND (MHz)	AVAILABLE CHANNEL	TESTED CHANNEL	MODULATION TECHNOLOGY	MODULATION TYPE	DATA RATE (Mbps)
-	802.11a	5180-5240	36 to 48	36, 40, 48	OFDM	BPSK	6.0
-	802.11n (HT20)		36 to 48	36, 40, 48	OFDM	BPSK	6.5
-	802.11n (HT40)		38 to 46	38, 46	OFDM	BPSK	13.5
-	802.11ac (VHT80)		42	42	OFDM	BPSK	97.5
-	802.11a	5745-5825	149 to 165	149, 157, 165	OFDM	BPSK	6.0
-	802.11n (HT20)		149 to 165	149, 157, 165	OFDM	BPSK	6.5
-	802.11n (HT40)		151 to 159	151, 159	OFDM	BPSK	13.5
-	802.11ac (VHT80)		155	155	OFDM	BPSK	97.5

Test Condition:

APPLICABLE TO	ENVIRONMENTAL CONDITIONS	INPUT POWER	TESTED BY
RE \geq 1G	19deg. C, 64%RH	120Vac, 60Hz	Jones Chang
RE $<$ 1G	25deg. C, 66%RH	120Vac, 60Hz	James Yang
PLC	25deg. C, 67%RH	120Vac, 60Hz	Jones Chang
APCM	25deg. C, 60%RH	120Vac, 60Hz	Ted Chang

3.3 Duty Cycle of Test Signal

Duty cycle of test signal is $\geq 98\%$, duty factor is not required.

Duty cycle of test signal is $< 98\%$, duty factor is required

802.11a: Duty cycle = $2.015/2.105 = 0.957$, Duty factor = $10 * \log(1/0.957) = 0.19$

802.11n (HT20): Duty cycle = $1.875/2.017 = 0.930$, Duty factor = $10 * \log(1/0.930) = 0.32$

802.11n (HT40): Duty cycle = $0.922/0.991 = 0.930$, Duty factor = $10 * \log(1/0.930) = 0.31$

802.11ac (VHT80): Duty cycle = $4.14/4.21 = 0.983$

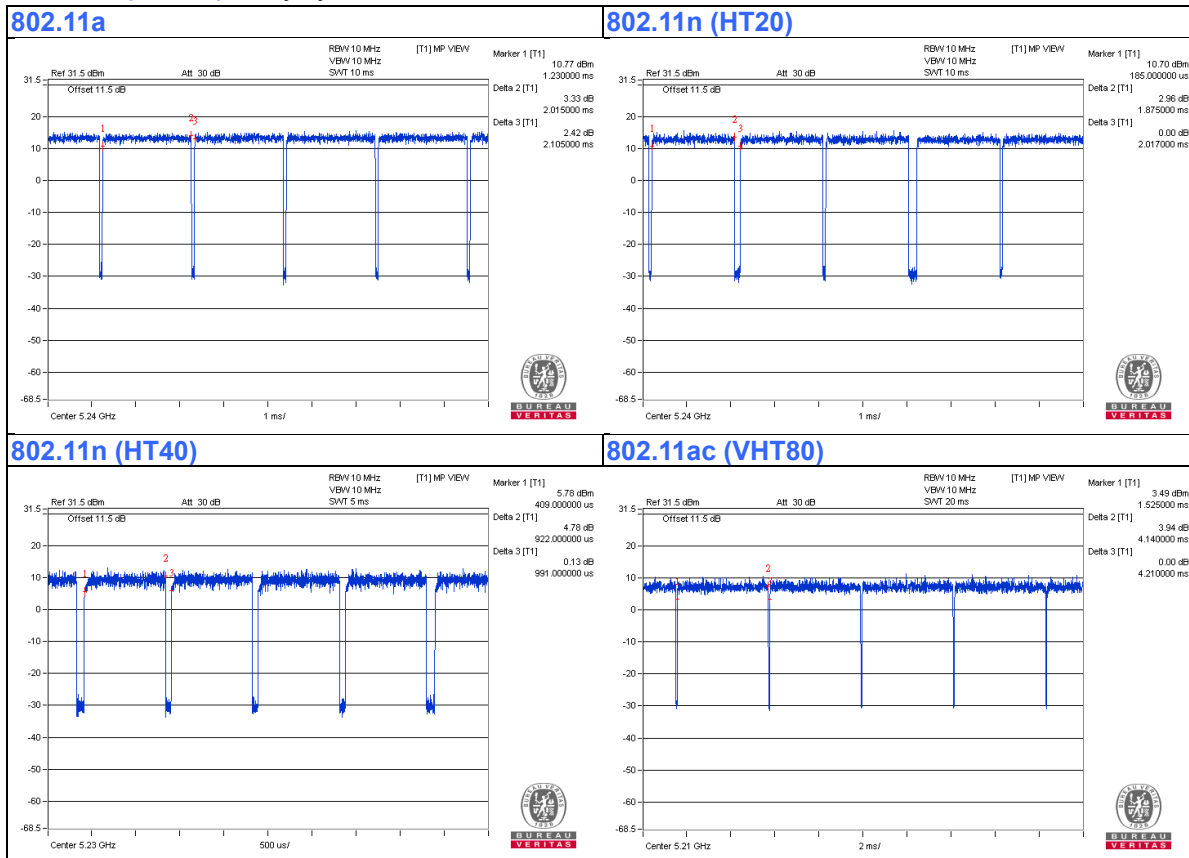

3.4 Description of Support Units

The EUT has been tested as an independent unit together with other necessary accessories or support units. The following support units or accessories were used to form a representative test configuration during the tests.

ID	Product	Brand	Model No.	Serial No.	FCC ID	Remarks
A.	Notebook	DELL	E5410	1HC2XM1	FCC DoC Approved	-
B.	Load	N/A	N/A	N/A	N/A	-
C.	PoE	EnGenius	EAP5006GP	N/A	N/A	Provided by manufacturer

Note:

1. All power cords of the above support units are non-shielded (1.8m).
2. Item A acted as communication partner to transfer data.

ID	Descriptions	Qty.	Length (m)	Shielding (Yes/No)	Cores (Qty.)	Remarks
1.	RJ45 Cable	1	1.8	N	0	Cat5e
2.	RJ45 Cable	1	10	N	0	Cat5e
3.	RJ45 Cable	1	1.8	N	0	Cat5e

3.4.1 Configuration of System under Test

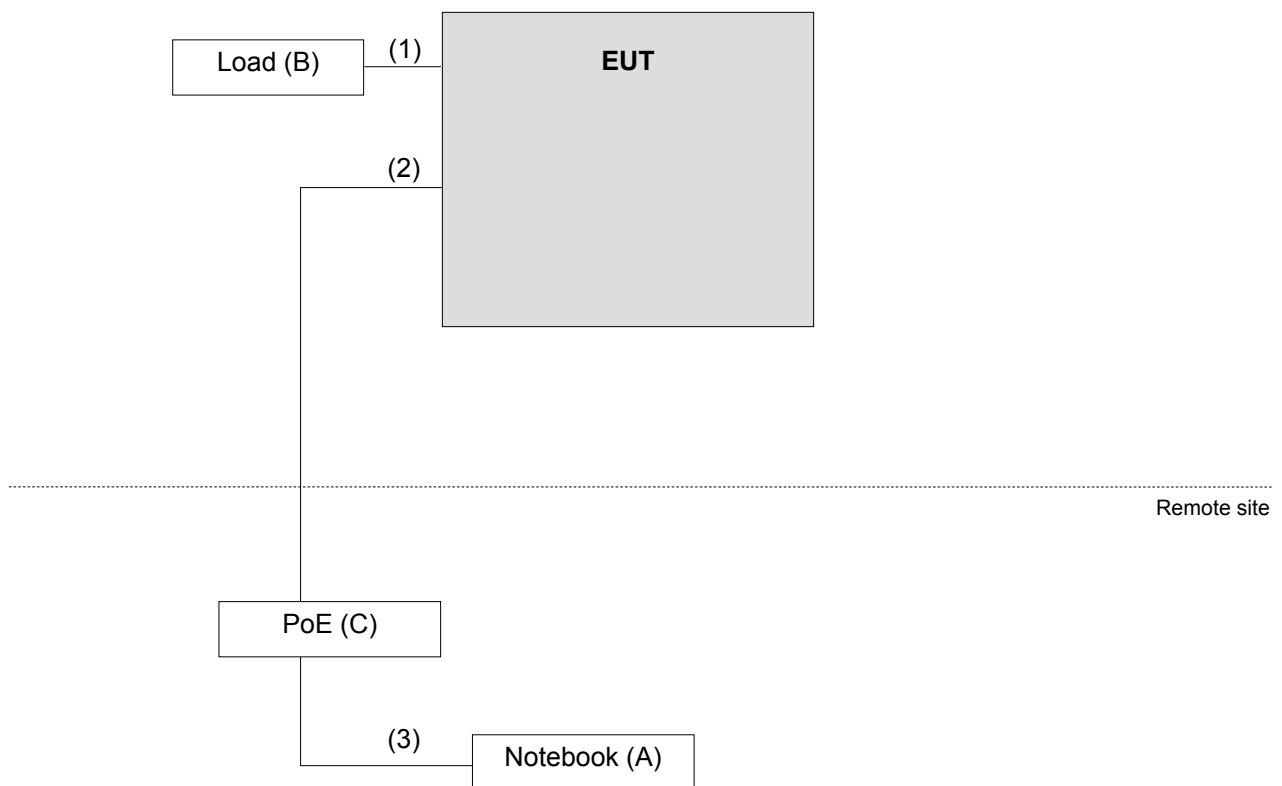

3.5 General Description of Applied Standard

The EUT is a RF Product. According to the specifications of the manufacturer, it must comply with the requirements of the following standards:

FCC Part 15, Subpart E (15.407)

KDB 789033 D02 General UNII Test Procedure New Rules v01r04

KDB 662911 D01 Multiple Transmitter Output v02r01

ANSI C63.10-2013

All test items have been performed and recorded as per the above standards.

NOTE: The EUT has been verified to comply with the requirements of FCC Part 15, Subpart B, Class B (DoC). The test report has been issued separately.

4 Test Types and Results

4.1 Radiated Emission and Bandedge Measurement

4.1.1 Limits of Radiated Emission and Bandedge Measurement

Radiated emissions which fall in the restricted bands must comply with the radiated emission limits specified as below table.

Frequencies (MHz)	Field Strength (microvolts/meter)	Measurement Distance (meters)
0.009 ~ 0.490	2400/F(kHz)	300
0.490 ~ 1.705	24000/F(kHz)	30
1.705 ~ 30.0	30	30
30 ~ 88	100	3
88 ~ 216	150	3
216 ~ 960	200	3
Above 960	500	3

NOTE:

1. The lower limit shall apply at the transition frequencies.
2. Emission level (dBuV/m) = 20 log Emission level (uV/m).
3. For frequencies above 1000MHz, the field strength limits are based on average detector, however, the peak field strength of any emission shall not exceed the maximum permitted average limits, specified above by more than 20dB under any Condition of modulation.

Limits of Unwanted Emission Out of the Restricted Bands

Applicable To		Limit	
789033 D02 General UNII Test Procedure New Rules v01r04		Field Strength at 3m	
		PK:74 (dBµV/m)	AV:54 (dBµV/m)
Frequency Band	Applicable To	EIRP Limit	Equivalent Field Strength at 3m
5150~5250 MHz	15.407(b)(1)	PK:-27 (dBm/MHz)	PK:68.2(dBµV/m)
5250~5350 MHz	15.407(b)(2)		
5470~5725 MHz	15.407(b)(3)		
5725~5850 MHz	<input checked="" type="checkbox"/> 15.407(b)(4)(i)	PK:-27 (dBm/MHz) ^{*1} PK:10 (dBm/MHz) ^{*2} PK:15.6 (dBm/MHz) ^{*3} PK:27 (dBm/MHz) ^{*4}	PK: 68.2(dBµV/m) ^{*1} PK:105.2 (dBµV/m) ^{*2} PK: 110.8(dBµV/m) ^{*3} PK:122.2 (dBµV/m) ^{*4}
	<input type="checkbox"/> 15.407(b)(4)(ii)	Emission limits in section 15.247(d)	
^{*1} beyond 75 MHz or more above of the band edge.		^{*2} below the band edge increasing linearly to 10 dBm/MHz at 25 MHz above.	
^{*3} below the band edge increasing linearly to a level of 15.6 dBm/MHz at 5 MHz above.		^{*4} from 5 MHz above or below the band edge increasing linearly to a level of 27 dBm/MHz at the band edge.	

NOTE: The following formula is used to convert the equipment isotropic radiated power (eirp) to field strength:

$$E = \frac{1000000 \sqrt{30P}}{3} \mu\text{V/m, where } P \text{ is the eirp (Watts).}$$

4.1.2 Test Instruments

Description & Manufacturer	Model No.	Serial No.	Cal. Date	Cal. Due
Test Receiver ROHDE & SCHWARZ	ESIB7	100187	May 02, 2017	May 01, 2018
Spectrum Analyzer ROHDE & SCHWARZ	FSP40	100041	Nov. 16, 2016	Nov. 15, 2017
BILOG Antenna SCHWARZBECK	VULB9168	9168-171	Dec. 28, 2016	Dec. 27, 2017
HORN Antenna SCHWARZBECK	9120D	209	Dec. 27, 2016	Dec. 26, 2017
HORN Antenna SCHWARZBECK	BBHA 9170	BBHA9170241	Dec. 14, 2016	Dec. 13, 2017
Loop Antenna	EM-6879	269	Aug. 11, 2016	Aug. 10, 2017
Preamplifier Agilent	8447D	2944A10738	Aug. 22, 2016	Aug. 21, 2017
Preamplifier Agilent	8449B	3008A01922	Sep. 18, 2016	Sep. 17, 2017
RF signal cable HUBER+SUHNER	SUCOFLEX 104	Cable-CH3-03 (214378)	Aug. 22, 2016	Aug. 21, 2017
RF signal cable HUBER+SUHNER	SUCOFLEX 106	Cable-CH3-03 (309224+12738)	Aug. 22, 2016	Aug. 21, 2017
Software BV ADT	ADT_Radiated_ V7.6.15.9.4	NA	NA	NA
Antenna Tower inn-co GmbH	MA 4000	013303	NA	NA
Antenna Tower Controller BV ADT	AT100	AT93021702	NA	NA
Turn Table BV ADT	TT100	TT93021702	NA	NA
Turn Table Controller BV ADT	SC100	SC93021702	NA	NA
High Speed Peak Power Meter	ML2495A	0824012	Aug. 11, 2016	Aug. 10, 2017
Power Sensor	MA2411B	0738171	Aug. 11, 2016	Aug. 10, 2017
26GHz ~ 40GHz Amplifier	EM26400	815221	Oct. 17, 2016	Oct. 16, 2017

- Note: 1. The calibration interval of the above test instruments is 12 months and the calibrations are traceable to NML/ROC and NIST/USA.
 2. The test was performed in HwaYa Chamber 3.
 3. The horn antenna and preamplifier (model: 8449B) are used only for the measurement of emission frequency above 1GHz if tested.
 4. The FCC Site Registration No. is 988962.
 5. The IC Site Registration No. is IC 7450F-3.

4.1.3 Test Procedure

For Radiated emission below 30MHz

- a. The EUT was placed on the top of a rotating table 0.8 meters above the ground at a 3 meter chamber room. The table was rotated 360 degrees to determine the position of the highest radiation.
- b. The EUT was set 3 meters away from the interference-receiving antenna, which was mounted on the top of a variable-height antenna tower.
- c. Both X and Y axes of the antenna are set to make the measurement.
- d. For each suspected emission, the EUT was arranged to its worst case and the rotatable table was turned from 0 degrees to 360 degrees to find the maximum reading.
- e. The test-receiver system was set to Quasi-Peak Detect Function and Specified Bandwidth with Maximum Hold Mode.

NOTE:

1. The resolution bandwidth and video bandwidth of test receiver/spectrum analyzer is 9kHz at frequency below 30MHz.

For Radiated emission above 30MHz

- a. The EUT was placed on the top of a rotating table 0.8 meters (for 30MHz ~ 1GHz) / 1.5 meters (for above 1GHz) above the ground at 3 meter chamber room for test. The table was rotated 360 degrees to determine the position of the highest radiation.
- b. The EUT was set 3 meters away from the interference-receiving antenna, which was mounted on the top of a variable-height antenna tower.
- c. The height of antenna is varied from one meter to four meters above the ground to determine the maximum value of the field strength. Both horizontal and vertical polarizations of the antenna are set to make the measurement.
- d. For each suspected emission, the EUT was arranged to its worst case and then the antenna was tuned to heights from 1 meter to 4 meters and the rotatable table was turned from 0 degrees to 360 degrees to find the maximum reading.
- e. The test-receiver system was set to quasi-peak detect function and specified bandwidth with maximum hold mode when the test frequency is below 1 GHz.
- f. The test-receiver system was set to peak and average detect function and specified bandwidth with maximum hold mode when the test frequency is above 1 GHz. If the peak reading value also meets average limit, measurement with the average detector is unnecessary.

Note:

1. The resolution bandwidth and video bandwidth of test receiver/spectrum analyzer is 120kHz for Quasi-peak detection (QP) at frequency below 1GHz.
2. The resolution bandwidth of test receiver/spectrum analyzer is 1 MHz and the video bandwidth is 3 MHz for Peak detection (PK) at frequency above 1GHz.
3. The resolution bandwidth of test receiver/spectrum analyzer is 1MHz and the video bandwidth is $\geq 1/T$ (Duty cycle < 98%) or 10Hz (Duty cycle $\geq 98\%$) for Average detection (AV) at frequency above 1GHz.
4. All modes of operation were investigated and the worst-case emissions are reported.

4.1.4 Deviation from Test Standard

No deviation.

4.1.5 Test Setup

For Radiated emission below 30MHz

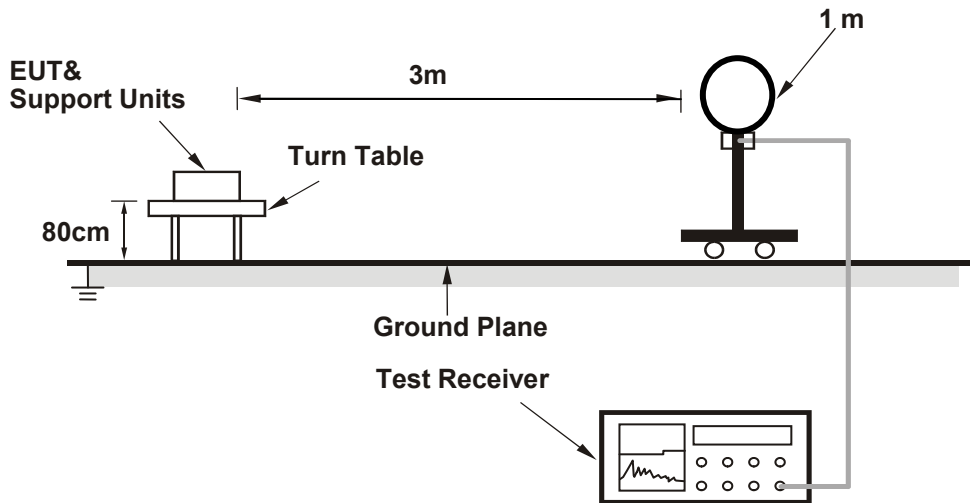

For Radiated emission 30MHz to 1GHz

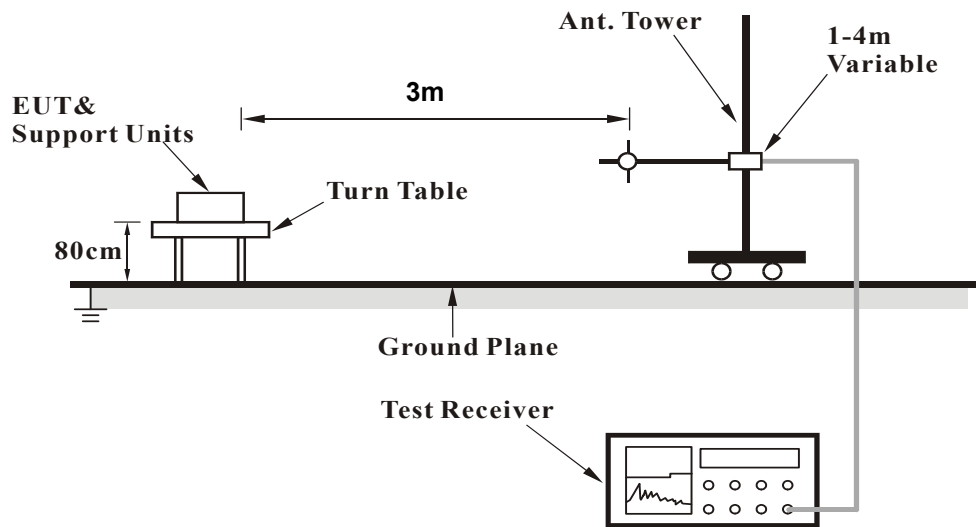

For Radiated emission above 1GHz

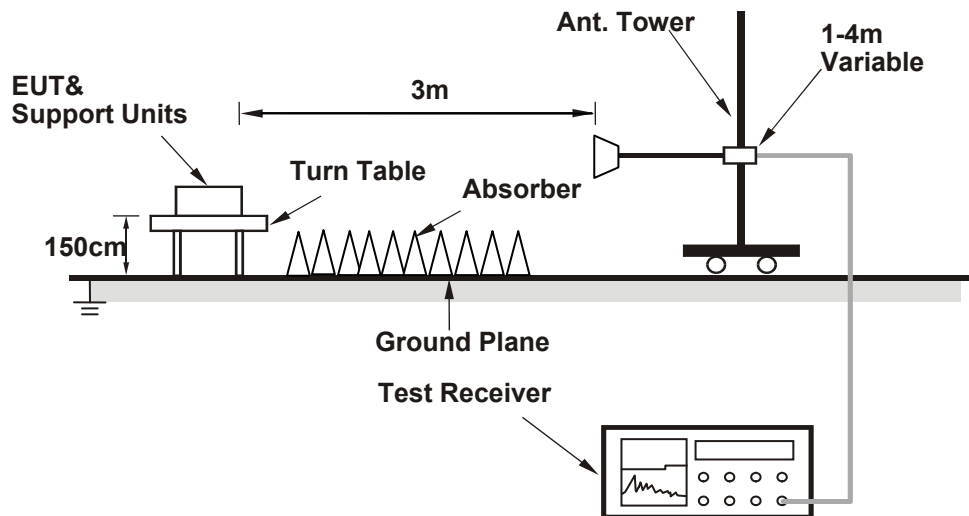

For the actual test configuration, please refer to the attached file (Test Setup Photo).

4.1.6 EUT Operating Conditions

- a. Placed the EUT on the testing table.
- b. Prepared notebook to act as a communication partner and placed it outside of testing area.
- c. The communication partner connected with EUT via a RJ45 cable and ran a test program (provided by manufacturer) to enable EUT under transmission condition continuously at specific channel frequency.
- d. The communication partner sent data to EUT by command "PING".

4.1.7 Test Results

ABOVE 1GHz DATA :

802.11a

CHANNEL	TX Channel 36	DETECTOR FUNCTION	Peak (PK)
FREQUENCY RANGE	1GHz ~ 40GHz		Average (AV)

ANTENNA POLARITY & TEST DISTANCE: HORIZONTAL AT 3 M								
NO.	FREQ. (MHz)	EMISSION LEVEL (dBuV/m)	LIMIT (dBuV/m)	MARGIN (dB)	ANTENNA HEIGHT (m)	TABLE ANGLE (Degree)	RAW VALUE (dBuV)	CORRECTION FACTOR (dB/m)
1	5150.00	56.6 PK	74.0	-17.4	1.67 H	351	55.80	0.80
2	5150.00	42.7 AV	54.0	-11.3	1.67 H	351	41.90	0.80
3	*5180.00	109.0 PK			1.64 H	333	70.30	38.70
4	*5180.00	98.1 AV			1.64 H	333	59.40	38.70
5	#10360.00	56.6 PK	74.0	-17.4	1.82 H	289	43.90	12.70
6	#10360.00	43.1 AV	54.0	-10.9	1.82 H	289	30.40	12.70
ANTENNA POLARITY & TEST DISTANCE: VERTICAL AT 3 M								
NO.	FREQ. (MHz)	EMISSION LEVEL (dBuV/m)	LIMIT (dBuV/m)	MARGIN (dB)	ANTENNA HEIGHT (m)	TABLE ANGLE (Degree)	RAW VALUE (dBuV)	CORRECTION FACTOR (dB/m)
1	5150.00	55.1 PK	74.0	-18.9	1.50 V	349	54.30	0.80
2	5150.00	41.8 AV	54.0	-12.2	1.50 V	349	41.00	0.80
3	*5180.00	106.5 PK			1.42 V	5	67.80	38.70
4	*5180.00	96.3 AV			1.42 V	5	57.60	38.70
5	#10360.00	56.3 PK	74.0	-17.7	2.21 V	312	43.60	12.70
6	#10360.00	42.9 AV	54.0	-11.1	2.21 V	312	30.20	12.70

REMARKS:

1. Emission Level(dBuV/m) = Raw Value(dBuV) + Correction Factor(dB/m)
2. Correction Factor(dB/m) = Antenna Factor(dB/m) + Cable Factor(dB)
3. The other emission levels were very low against the limit.
4. Margin value = Emission Level – Limit value
5. " * ": Fundamental frequency.
6. " # ": The radiated frequency is out of the restricted band.

CHANNEL	TX Channel 40	DETECTOR FUNCTION	Peak (PK)
FREQUENCY RANGE	1GHz ~ 40GHz		Average (AV)

ANTENNA POLARITY & TEST DISTANCE: HORIZONTAL AT 3 M

NO.	FREQ. (MHz)	EMISSION LEVEL (dBuV/m)	LIMIT (dBuV/m)	MARGIN (dB)	ANTENNA HEIGHT (m)	TABLE ANGLE (Degree)	RAW VALUE (dBuV)	CORRECTION FACTOR (dB/m)
1	*5200.00	108.7 PK			1.65 H	341	70.00	38.70
2	*5200.00	97.9 AV			1.65 H	341	59.20	38.70
3	#10400.00	56.8 PK	74.0	-17.2	2.18 H	339	44.10	12.70
4	#10400.00	43.3 AV	54.0	-10.7	2.18 H	339	30.60	12.70

ANTENNA POLARITY & TEST DISTANCE: VERTICAL AT 3 M

NO.	FREQ. (MHz)	EMISSION LEVEL (dBuV/m)	LIMIT (dBuV/m)	MARGIN (dB)	ANTENNA HEIGHT (m)	TABLE ANGLE (Degree)	RAW VALUE (dBuV)	CORRECTION FACTOR (dB/m)
1	*5200.00	107.3 PK			1.25 V	179	68.60	38.70
2	*5200.00	97.0 AV			1.25 V	179	58.30	38.70
3	#10400.00	56.8 PK	74.0	-17.2	2.18 V	347	44.10	12.70
4	#10400.00	43.2 AV	54.0	-10.8	2.18 V	347	30.50	12.70

REMARKS:

1. Emission Level(dBuV/m) = Raw Value(dBuV) + Correction Factor(dB/m)
2. Correction Factor(dB/m) = Antenna Factor(dB/m) + Cable Factor(dB)
3. The other emission levels were very low against the limit.
4. Margin value = Emission Level – Limit value
5. " * ": Fundamental frequency.
6. " # ": The radiated frequency is out of the restricted band.

CHANNEL	TX Channel 48	DETECTOR FUNCTION	Peak (PK)
FREQUENCY RANGE	1GHz ~ 40GHz		Average (AV)

ANTENNA POLARITY & TEST DISTANCE: HORIZONTAL AT 3 M

NO.	FREQ. (MHz)	EMISSION LEVEL (dBuV/m)	LIMIT (dBuV/m)	MARGIN (dB)	ANTENNA HEIGHT (m)	TABLE ANGLE (Degree)	RAW VALUE (dBuV)	CORRECTION FACTOR (dB/m)
1	*5240.00	107.8 PK			2.00 H	354	69.00	38.80
2	*5240.00	96.8 AV			2.00 H	354	58.00	38.80
3	5350.00	56.9 PK	74.0	-17.1	2.03 H	332	55.80	1.10
4	5350.00	43.6 AV	54.0	-10.4	2.03 H	332	42.50	1.10
5	#10480.00	57.2 PK	74.0	-16.8	1.35 H	250	43.70	13.50
6	#10480.00	43.9 AV	54.0	-10.1	1.35 H	250	30.40	13.50

ANTENNA POLARITY & TEST DISTANCE: VERTICAL AT 3 M

NO.	FREQ. (MHz)	EMISSION LEVEL (dBuV/m)	LIMIT (dBuV/m)	MARGIN (dB)	ANTENNA HEIGHT (m)	TABLE ANGLE (Degree)	RAW VALUE (dBuV)	CORRECTION FACTOR (dB/m)
1	*5240.00	108.2 PK			1.24 V	2	69.40	38.80
2	*5240.00	97.5 AV			1.24 V	2	58.70	38.80
3	5350.00	55.8 PK	74.0	-18.2	1.24 V	83	54.70	1.10
4	5350.00	42.4 AV	54.0	-11.6	1.24 V	83	41.30	1.10
5	#10480.00	57.4 PK	74.0	-16.6	1.19 V	184	43.90	13.50
6	#10480.00	43.8 AV	54.0	-10.2	1.19 V	184	30.30	13.50

REMARKS:

1. Emission Level(dBuV/m) = Raw Value(dBuV) + Correction Factor(dB/m)
2. Correction Factor(dB/m) = Antenna Factor(dB/m) + Cable Factor(dB)
3. The other emission levels were very low against the limit.
4. Margin value = Emission Level – Limit value
5. " * ": Fundamental frequency.
6. " # ": The radiated frequency is out of the restricted band.

CHANNEL	TX Channel 149	DETECTOR FUNCTION	Peak (PK)
FREQUENCY RANGE	1GHz ~ 40GHz		Average (AV)

ANTENNA POLARITY & TEST DISTANCE: HORIZONTAL AT 3 M

NO.	FREQ. (MHz)	EMISSION LEVEL (dBuV/m)	LIMIT (dBuV/m)	MARGIN (dB)	ANTENNA HEIGHT (m)	TABLE ANGLE (Degree)	RAW VALUE (dBuV)	CORRECTION FACTOR (dB/m)
1	*5745.00	123.4 PK			2.20 H	0	83.50	39.90
2	*5745.00	112.7 AV			2.20 H	0	72.80	39.90
3	11490.00	62.4 PK	74.0	-11.6	1.31 H	356	47.90	14.50
4	11490.00	48.6 AV	54.0	-5.4	1.31 H	356	34.10	14.50
5	#5621.60	59.6 PK	68.2	-8.6	2.20 H	0	57.90	1.70
6	#5952.80	57.5 PK	68.2	-10.7	2.20 H	0	54.90	2.60

ANTENNA POLARITY & TEST DISTANCE: VERTICAL AT 3 M

NO.	FREQ. (MHz)	EMISSION LEVEL (dBuV/m)	LIMIT (dBuV/m)	MARGIN (dB)	ANTENNA HEIGHT (m)	TABLE ANGLE (Degree)	RAW VALUE (dBuV)	CORRECTION FACTOR (dB/m)
1	*5745.00	119.0 PK			1.95 V	321	79.10	39.90
2	*5745.00	108.8 AV			1.95 V	321	68.90	39.90
3	11490.00	62.7 PK	74.0	-11.3	2.76 V	360	48.20	14.50
4	11490.00	49.2 AV	54.0	-4.8	2.76 V	360	34.70	14.50
5	#5646.40	57.9 PK	68.2	-10.3	1.95 V	321	56.20	1.70
6	#5985.60	56.9 PK	68.2	-11.3	1.95 V	321	54.10	2.80

REMARKS:

1. Emission Level(dBuV/m) = Raw Value(dBuV) + Correction Factor(dB/m)
2. Correction Factor(dB/m) = Antenna Factor(dB/m) + Cable Factor(dB)
3. The other emission levels were very low against the limit.
4. Margin value = Emission Level – Limit value
5. " * ": Fundamental frequency.
6. " # ": The radiated frequency is out of the restricted band.

CHANNEL	TX Channel 157	DETECTOR FUNCTION	Peak (PK)
FREQUENCY RANGE	1GHz ~ 40GHz		Average (AV)

ANTENNA POLARITY & TEST DISTANCE: HORIZONTAL AT 3 M

NO.	FREQ. (MHz)	EMISSION LEVEL (dBuV/m)	LIMIT (dBuV/m)	MARGIN (dB)	ANTENNA HEIGHT (m)	TABLE ANGLE (Degree)	RAW VALUE (dBuV)	CORRECTION FACTOR (dB/m)
1	*5785.00	124.3 PK			2.55 H	342	84.20	40.10
2	*5785.00	113.7 AV			2.55 H	342	73.60	40.10
3	11570.00	63.5 PK	74.0	-10.5	1.30 H	329	49.20	14.30
4	11570.00	49.8 AV	54.0	-4.2	1.30 H	329	35.50	14.30
5	#5625.60	59.7 PK	68.2	-8.5	2.55 H	342	58.00	1.70
6	#5984.00	59.3 PK	68.2	-8.9	2.55 H	342	56.50	2.80

ANTENNA POLARITY & TEST DISTANCE: VERTICAL AT 3 M

NO.	FREQ. (MHz)	EMISSION LEVEL (dBuV/m)	LIMIT (dBuV/m)	MARGIN (dB)	ANTENNA HEIGHT (m)	TABLE ANGLE (Degree)	RAW VALUE (dBuV)	CORRECTION FACTOR (dB/m)
1	*5785.00	119.6 PK			2.33 V	358	79.50	40.10
2	*5785.00	108.8 AV			2.33 V	358	68.70	40.10
3	11570.00	63.2 PK	74.0	-10.8	1.19 V	358	48.90	14.30
4	11570.00	49.3 AV	54.0	-4.7	1.19 V	358	35.00	14.30
5	#5619.20	56.6 PK	68.2	-11.6	2.33 V	358	54.90	1.70
6	#5970.40	56.6 PK	68.2	-11.6	2.33 V	358	53.90	2.70

REMARKS:

1. Emission Level(dBuV/m) = Raw Value(dBuV) + Correction Factor(dB/m)
2. Correction Factor(dB/m) = Antenna Factor(dB/m) + Cable Factor(dB)
3. The other emission levels were very low against the limit.
4. Margin value = Emission Level – Limit value
5. " * ": Fundamental frequency.
6. " # ": The radiated frequency is out of the restricted band.

CHANNEL	TX Channel 165	DETECTOR FUNCTION	Peak (PK)
FREQUENCY RANGE	1GHz ~ 40GHz		Average (AV)

ANTENNA POLARITY & TEST DISTANCE: HORIZONTAL AT 3 M

NO.	FREQ. (MHz)	EMISSION LEVEL (dBuV/m)	LIMIT (dBuV/m)	MARGIN (dB)	ANTENNA HEIGHT (m)	TABLE ANGLE (Degree)	RAW VALUE (dBuV)	CORRECTION FACTOR (dB/m)
1	*5825.00	123.0 PK			2.25 H	328	82.80	40.20
2	*5825.00	112.3 AV			2.25 H	328	72.10	40.20
3	11650.00	63.3 PK	74.0	-10.7	2.33 H	360	48.90	14.40
4	11650.00	49.1 AV	54.0	-4.9	2.33 H	360	34.70	14.40
5	#5641.60	60.6 PK	68.2	-7.6	2.25 H	328	58.90	1.70
6	#5977.60	58.2 PK	68.2	-10.0	2.25 H	328	55.40	2.80

ANTENNA POLARITY & TEST DISTANCE: VERTICAL AT 3 M

NO.	FREQ. (MHz)	EMISSION LEVEL (dBuV/m)	LIMIT (dBuV/m)	MARGIN (dB)	ANTENNA HEIGHT (m)	TABLE ANGLE (Degree)	RAW VALUE (dBuV)	CORRECTION FACTOR (dB/m)
1	*5825.00	119.7 PK			2.27 V	326	79.50	40.20
2	*5825.00	109.4 AV			2.27 V	326	69.20	40.20
3	11650.00	64.2 PK	74.0	-9.8	3.17 V	179	49.80	14.40
4	11650.00	50.3 AV	54.0	-3.7	3.17 V	179	35.90	14.40
5	#5609.60	57.5 PK	68.2	-10.7	2.27 V	326	55.80	1.70
6	#5983.20	57.1 PK	68.2	-11.1	2.27 V	326	54.30	2.80

REMARKS:

1. Emission Level(dBuV/m) = Raw Value(dBuV) + Correction Factor(dB/m)
2. Correction Factor(dB/m) = Antenna Factor(dB/m) + Cable Factor(dB)
3. The other emission levels were very low against the limit.
4. Margin value = Emission Level – Limit value
5. " * ": Fundamental frequency.
6. " # ": The radiated frequency is out of the restricted band.

802.11n (HT20)

CHANNEL	TX Channel 36	DETECTOR FUNCTION	Peak (PK)
FREQUENCY RANGE	1GHz ~ 40GHz		Average (AV)

ANTENNA POLARITY & TEST DISTANCE: HORIZONTAL AT 3 M

NO.	FREQ. (MHz)	EMISSION LEVEL (dBuV/m)	LIMIT (dBuV/m)	MARGIN (dB)	ANTENNA HEIGHT (m)	TABLE ANGLE (Degree)	RAW VALUE (dBuV)	CORRECTION FACTOR (dB/m)
1	5150.00	54.7 PK	74.0	-19.3	1.73 H	350	53.90	0.80
2	5150.00	41.9 AV	54.0	-12.1	1.73 H	350	41.10	0.80
3	*5180.00	106.0 PK			1.67 H	351	67.30	38.70
4	*5180.00	95.4 AV			1.67 H	351	56.70	38.70
5	#10360.00	56.8 PK	74.0	-17.2	1.82 H	36	44.10	12.70
6	#10360.00	42.8 AV	54.0	-11.2	1.82 H	36	30.10	12.70

ANTENNA POLARITY & TEST DISTANCE: VERTICAL AT 3 M

NO.	FREQ. (MHz)	EMISSION LEVEL (dBuV/m)	LIMIT (dBuV/m)	MARGIN (dB)	ANTENNA HEIGHT (m)	TABLE ANGLE (Degree)	RAW VALUE (dBuV)	CORRECTION FACTOR (dB/m)
1	5150.00	55.2 PK	74.0	-18.8	1.33 V	317	54.40	0.80
2	5150.00	41.6 AV	54.0	-12.4	1.33 V	317	40.80	0.80
3	*5180.00	106.0 PK			1.29 V	147	67.30	38.70
4	*5180.00	95.6 AV			1.29 V	147	56.90	38.70
5	#10360.00	56.6 PK	74.0	-17.4	1.53 V	143	43.90	12.70
6	#10360.00	43.5 AV	54.0	-10.5	1.53 V	143	30.80	12.70

REMARKS:

1. Emission Level(dBuV/m) = Raw Value(dBuV) + Correction Factor(dB/m)
2. Correction Factor(dB/m) = Antenna Factor(dB/m) + Cable Factor(dB)
3. The other emission levels were very low against the limit.
4. Margin value = Emission Level – Limit value
5. " * ": Fundamental frequency.
6. " # ": The radiated frequency is out of the restricted band.

CHANNEL	TX Channel 40	DETECTOR FUNCTION	Peak (PK)
FREQUENCY RANGE	1GHz ~ 40GHz		Average (AV)

ANTENNA POLARITY & TEST DISTANCE: HORIZONTAL AT 3 M

NO.	FREQ. (MHz)	EMISSION LEVEL (dBuV/m)	LIMIT (dBuV/m)	MARGIN (dB)	ANTENNA HEIGHT (m)	TABLE ANGLE (Degree)	RAW VALUE (dBuV)	CORRECTION FACTOR (dB/m)
1	*5200.00	108.0 PK			1.67 H	336	69.30	38.70
2	*5200.00	97.1 AV			1.67 H	336	58.40	38.70
3	#10400.00	57.1 PK	74.0	-16.9	1.86 H	351	44.40	12.70
4	#10400.00	43.5 AV	54.0	-10.5	1.86 H	351	30.80	12.70

ANTENNA POLARITY & TEST DISTANCE: VERTICAL AT 3 M

NO.	FREQ. (MHz)	EMISSION LEVEL (dBuV/m)	LIMIT (dBuV/m)	MARGIN (dB)	ANTENNA HEIGHT (m)	TABLE ANGLE (Degree)	RAW VALUE (dBuV)	CORRECTION FACTOR (dB/m)
1	*5200.00	105.6 PK			1.44 V	165	66.90	38.70
2	*5200.00	95.4 AV			1.44 V	165	56.70	38.70
3	#10400.00	57.2 PK	74.0	-16.8	1.31 V	253	44.50	12.70
4	#10400.00	43.2 AV	54.0	-10.8	1.31 V	253	30.50	12.70

REMARKS:

1. Emission Level(dBuV/m) = Raw Value(dBuV) + Correction Factor(dB/m)
2. Correction Factor(dB/m) = Antenna Factor(dB/m) + Cable Factor(dB)
3. The other emission levels were very low against the limit.
4. Margin value = Emission Level – Limit value
5. " * ": Fundamental frequency.
6. " # ": The radiated frequency is out of the restricted band.

CHANNEL	TX Channel 48	DETECTOR FUNCTION	Peak (PK)
FREQUENCY RANGE	1GHz ~ 40GHz		Average (AV)

ANTENNA POLARITY & TEST DISTANCE: HORIZONTAL AT 3 M

NO.	FREQ. (MHz)	EMISSION LEVEL (dBuV/m)	LIMIT (dBuV/m)	MARGIN (dB)	ANTENNA HEIGHT (m)	TABLE ANGLE (Degree)	RAW VALUE (dBuV)	CORRECTION FACTOR (dB/m)
1	*5240.00	108.5 PK			1.80 H	337	69.70	38.80
2	*5240.00	97.3 AV			1.80 H	337	58.50	38.80
3	5350.00	55.9 PK	74.0	-18.1	1.66 H	348	54.80	1.10
4	5350.00	43.3 AV	54.0	-10.7	1.66 H	348	42.20	1.10
5	#10480.00	57.6 PK	74.0	-16.4	1.63 H	162	44.10	13.50
6	#10480.00	43.8 AV	54.0	-10.2	1.63 H	162	30.30	13.50

ANTENNA POLARITY & TEST DISTANCE: VERTICAL AT 3 M

NO.	FREQ. (MHz)	EMISSION LEVEL (dBuV/m)	LIMIT (dBuV/m)	MARGIN (dB)	ANTENNA HEIGHT (m)	TABLE ANGLE (Degree)	RAW VALUE (dBuV)	CORRECTION FACTOR (dB/m)
1	*5240.00	105.9 PK			1.41 V	170	67.10	38.80
2	*5240.00	95.6 AV			1.41 V	170	56.80	38.80
3	5350.00	55.7 PK	74.0	-18.3	1.12 V	184	54.60	1.10
4	5350.00	42.1 AV	54.0	-11.9	1.12 V	184	41.00	1.10
5	#10480.00	57.2 PK	74.0	-16.8	1.49 V	261	43.70	13.50
6	#10480.00	44.0 AV	54.0	-10.0	1.49 V	261	30.50	13.50

REMARKS:

1. Emission Level(dBuV/m) = Raw Value(dBuV) + Correction Factor(dB/m)
2. Correction Factor(dB/m) = Antenna Factor(dB/m) + Cable Factor(dB)
3. The other emission levels were very low against the limit.
4. Margin value = Emission Level – Limit value
5. " * ": Fundamental frequency.
6. " # ": The radiated frequency is out of the restricted band.

CHANNEL	TX Channel 149	DETECTOR FUNCTION	Peak (PK)
FREQUENCY RANGE	1GHz ~ 40GHz		Average (AV)

ANTENNA POLARITY & TEST DISTANCE: HORIZONTAL AT 3 M

NO.	FREQ. (MHz)	EMISSION LEVEL (dBuV/m)	LIMIT (dBuV/m)	MARGIN (dB)	ANTENNA HEIGHT (m)	TABLE ANGLE (Degree)	RAW VALUE (dBuV)	CORRECTION FACTOR (dB/m)
1	*5745.00	122.8 PK			2.17 H	335	82.90	39.90
2	*5745.00	112.2 AV			2.17 H	335	72.30	39.90
3	11490.00	62.2 PK	74.0	-11.8	1.14 H	180	47.70	14.50
4	11490.00	48.7 AV	54.0	-5.3	1.14 H	180	34.20	14.50
5	#5620.80	62.8 PK	68.2	-5.4	2.17 H	335	61.10	1.70
6	#5983.20	61.9 PK	68.2	-6.3	2.17 H	335	59.10	2.80

ANTENNA POLARITY & TEST DISTANCE: VERTICAL AT 3 M

NO.	FREQ. (MHz)	EMISSION LEVEL (dBuV/m)	LIMIT (dBuV/m)	MARGIN (dB)	ANTENNA HEIGHT (m)	TABLE ANGLE (Degree)	RAW VALUE (dBuV)	CORRECTION FACTOR (dB/m)
1	*5745.00	119.3 PK			2.00 V	319	79.40	39.90
2	*5745.00	108.4 AV			2.00 V	319	68.50	39.90
3	11490.00	61.8 PK	74.0	-12.2	2.78 V	360	47.30	14.50
4	11490.00	48.5 AV	54.0	-5.5	2.78 V	360	34.00	14.50
5	#5625.60	57.3 PK	68.2	-10.9	2.00 V	319	55.60	1.70
6	#5994.40	57.2 PK	68.2	-11.0	2.00 V	319	54.40	2.80

REMARKS:

1. Emission Level(dBuV/m) = Raw Value(dBuV) + Correction Factor(dB/m)
2. Correction Factor(dB/m) = Antenna Factor(dB/m) + Cable Factor(dB)
3. The other emission levels were very low against the limit.
4. Margin value = Emission Level – Limit value
5. " * ": Fundamental frequency.
6. " # ": The radiated frequency is out of the restricted band.

CHANNEL	TX Channel 157	DETECTOR FUNCTION	Peak (PK)
FREQUENCY RANGE	1GHz ~ 40GHz		Average (AV)

ANTENNA POLARITY & TEST DISTANCE: HORIZONTAL AT 3 M

NO.	FREQ. (MHz)	EMISSION LEVEL (dBuV/m)	LIMIT (dBuV/m)	MARGIN (dB)	ANTENNA HEIGHT (m)	TABLE ANGLE (Degree)	RAW VALUE (dBuV)	CORRECTION FACTOR (dB/m)
1	*5785.00	124.0 PK			2.56 H	337	83.90	40.10
2	*5785.00	113.5 AV			2.56 H	337	73.40	40.10
3	11570.00	62.7 PK	74.0	-11.3	1.33 H	329	48.40	14.30
4	11570.00	49.4 AV	54.0	-4.6	1.33 H	329	35.10	14.30
5	#5635.20	63.0 PK	68.2	-5.2	2.56 H	337	61.30	1.70
6	#5981.60	62.5 PK	68.2	-5.7	2.56 H	337	59.70	2.80

ANTENNA POLARITY & TEST DISTANCE: VERTICAL AT 3 M

NO.	FREQ. (MHz)	EMISSION LEVEL (dBuV/m)	LIMIT (dBuV/m)	MARGIN (dB)	ANTENNA HEIGHT (m)	TABLE ANGLE (Degree)	RAW VALUE (dBuV)	CORRECTION FACTOR (dB/m)
1	*5785.00	119.0 PK			2.38 V	360	78.90	40.10
2	*5785.00	108.6 AV			2.38 V	360	68.50	40.10
3	11570.00	62.9 PK	74.0	-11.1	2.89 V	360	48.60	14.30
4	11570.00	48.8 AV	54.0	-5.2	2.89 V	360	34.50	14.30
5	#5640.00	57.0 PK	68.2	-11.2	2.38 V	360	55.30	1.70
6	#5958.40	56.9 PK	68.2	-11.3	2.38 V	360	54.30	2.60

REMARKS:

1. Emission Level(dBuV/m) = Raw Value(dBuV) + Correction Factor(dB/m)
2. Correction Factor(dB/m) = Antenna Factor(dB/m) + Cable Factor(dB)
3. The other emission levels were very low against the limit.
4. Margin value = Emission Level – Limit value
5. " * ": Fundamental frequency.
6. " # ": The radiated frequency is out of the restricted band.

CHANNEL	TX Channel 165	DETECTOR FUNCTION	Peak (PK)
FREQUENCY RANGE	1GHz ~ 40GHz		Average (AV)

ANTENNA POLARITY & TEST DISTANCE: HORIZONTAL AT 3 M

NO.	FREQ. (MHz)	EMISSION LEVEL (dBuV/m)	LIMIT (dBuV/m)	MARGIN (dB)	ANTENNA HEIGHT (m)	TABLE ANGLE (Degree)	RAW VALUE (dBuV)	CORRECTION FACTOR (dB/m)
1	*5825.00	123.3 PK			2.25 H	335	83.10	40.20
2	*5825.00	112.6 AV			2.25 H	335	72.40	40.20
3	11650.00	61.9 PK	74.0	-12.1	2.33 H	359	47.50	14.40
4	11650.00	48.7 AV	54.0	-5.3	2.33 H	359	34.30	14.40
5	#5624.00	63.1 PK	68.2	-5.1	2.25 H	335	61.40	1.70
6	#5993.60	62.1 PK	68.2	-6.1	2.25 H	335	59.30	2.80

ANTENNA POLARITY & TEST DISTANCE: VERTICAL AT 3 M

NO.	FREQ. (MHz)	EMISSION LEVEL (dBuV/m)	LIMIT (dBuV/m)	MARGIN (dB)	ANTENNA HEIGHT (m)	TABLE ANGLE (Degree)	RAW VALUE (dBuV)	CORRECTION FACTOR (dB/m)
1	*5825.00	119.2 PK			2.45 V	345	79.00	40.20
2	*5825.00	109.1 AV			2.45 V	345	68.90	40.20
3	11650.00	64.2 PK	74.0	-9.8	3.34 V	168	49.80	14.40
4	11650.00	49.9 AV	54.0	-4.1	3.34 V	168	35.50	14.40
5	#5616.80	57.1 PK	68.2	-11.1	2.45 V	345	55.40	1.70
6	#5975.20	57.2 PK	68.2	-11.0	2.45 V	345	54.40	2.80

REMARKS:

1. Emission Level(dBuV/m) = Raw Value(dBuV) + Correction Factor(dB/m)
2. Correction Factor(dB/m) = Antenna Factor(dB/m) + Cable Factor(dB)
3. The other emission levels were very low against the limit.
4. Margin value = Emission Level – Limit value
5. " * ": Fundamental frequency.
6. " # ": The radiated frequency is out of the restricted band.

802.11n (HT40)

CHANNEL	TX Channel 38	DETECTOR FUNCTION	Peak (PK)
FREQUENCY RANGE	1GHz ~ 40GHz		Average (AV)

ANTENNA POLARITY & TEST DISTANCE: HORIZONTAL AT 3 M								
NO.	FREQ. (MHz)	EMISSION LEVEL (dBuV/m)	LIMIT (dBuV/m)	MARGIN (dB)	ANTENNA HEIGHT (m)	TABLE ANGLE (Degree)	RAW VALUE (dBuV)	CORRECTION FACTOR (dB/m)
1	5150.00	57.3 PK	74.0	-16.7	1.90 H	343	56.50	0.80
2	5150.00	44.4 AV	54.0	-9.6	1.90 H	343	43.60	0.80
3	*5190.00	105.0 PK			1.66 H	343	66.30	38.70
4	*5190.00	94.0 AV			1.66 H	343	55.30	38.70
5	#10380.00	57.5 PK	74.0	-16.5	1.83 H	326	44.70	12.80
6	#10380.00	44.0 AV	54.0	-10.0	1.83 H	326	31.20	12.80

ANTENNA POLARITY & TEST DISTANCE: VERTICAL AT 3 M								
NO.	FREQ. (MHz)	EMISSION LEVEL (dBuV/m)	LIMIT (dBuV/m)	MARGIN (dB)	ANTENNA HEIGHT (m)	TABLE ANGLE (Degree)	RAW VALUE (dBuV)	CORRECTION FACTOR (dB/m)
1	5150.00	58.7 PK	74.0	-15.3	1.20 V	172	57.90	0.80
2	5150.00	44.9 AV	54.0	-9.1	1.20 V	172	44.10	0.80
3	*5190.00	104.0 PK			1.28 V	180	65.30	38.70
4	*5190.00	93.8 AV			1.28 V	180	55.10	38.70
5	#10380.00	57.4 PK	74.0	-16.6	1.43 V	200	44.60	12.80
6	#10380.00	43.9 AV	54.0	-10.1	1.43 V	200	31.10	12.80

REMARKS:

1. Emission Level(dBuV/m) = Raw Value(dBuV) + Correction Factor(dB/m)
2. Correction Factor(dB/m) = Antenna Factor(dB/m) + Cable Factor(dB)
3. The other emission levels were very low against the limit.
4. Margin value = Emission Level – Limit value
5. " * ": Fundamental frequency.
6. " # ": The radiated frequency is out of the restricted band.

CHANNEL	TX Channel 46	DETECTOR FUNCTION	Peak (PK)
FREQUENCY RANGE	1GHz ~ 40GHz		Average (AV)

ANTENNA POLARITY & TEST DISTANCE: HORIZONTAL AT 3 M

NO.	FREQ. (MHz)	EMISSION LEVEL (dBuV/m)	LIMIT (dBuV/m)	MARGIN (dB)	ANTENNA HEIGHT (m)	TABLE ANGLE (Degree)	RAW VALUE (dBuV)	CORRECTION FACTOR (dB/m)
1	*5230.00	104.6 PK			1.62 H	341	65.80	38.80
2	*5230.00	93.7 AV			1.62 H	341	54.90	38.80
3	5350.00	57.2 PK	74.0	-16.8	1.90 H	342	56.10	1.10
4	5350.00	43.2 AV	54.0	-10.8	1.90 H	342	42.10	1.10
5	#10460.00	57.1 PK	74.0	-16.9	1.43 H	338	43.80	13.30
6	#10460.00	43.6 AV	54.0	-10.4	1.43 H	338	30.30	13.30

ANTENNA POLARITY & TEST DISTANCE: VERTICAL AT 3 M

NO.	FREQ. (MHz)	EMISSION LEVEL (dBuV/m)	LIMIT (dBuV/m)	MARGIN (dB)	ANTENNA HEIGHT (m)	TABLE ANGLE (Degree)	RAW VALUE (dBuV)	CORRECTION FACTOR (dB/m)
1	*5230.00	103.0 PK			1.37 V	150	64.20	38.80
2	*5230.00	93.1 AV			1.37 V	150	54.30	38.80
3	5350.00	54.9 PK	74.0	-19.1	1.44 V	161	53.80	1.10
4	5350.00	42.5 AV	54.0	-11.5	1.44 V	161	41.40	1.10
5	#10460.00	56.9 PK	74.0	-17.1	1.39 V	195	43.60	13.30
6	#10460.00	43.8 AV	54.0	-10.2	1.39 V	195	30.50	13.30

REMARKS:

1. Emission Level(dBuV/m) = Raw Value(dBuV) + Correction Factor(dB/m)
2. Correction Factor(dB/m) = Antenna Factor(dB/m) + Cable Factor(dB)
3. The other emission levels were very low against the limit.
4. Margin value = Emission Level – Limit value
5. " * ": Fundamental frequency.
6. " # ": The radiated frequency is out of the restricted band.

CHANNEL	TX Channel 151	DETECTOR FUNCTION	Peak (PK)
FREQUENCY RANGE	1GHz ~ 40GHz		Average (AV)

ANTENNA POLARITY & TEST DISTANCE: HORIZONTAL AT 3 M

NO.	FREQ. (MHz)	EMISSION LEVEL (dBuV/m)	LIMIT (dBuV/m)	MARGIN (dB)	ANTENNA HEIGHT (m)	TABLE ANGLE (Degree)	RAW VALUE (dBuV)	CORRECTION FACTOR (dB/m)
1	*5755.00	119.9 PK			2.16 H	3	80.00	39.90
2	*5755.00	109.7 AV			2.16 H	3	69.80	39.90
3	11510.00	62.4 PK	74.0	-11.6	1.20 H	180	47.90	14.50
4	11510.00	47.9 AV	54.0	-6.1	1.20 H	180	33.40	14.50
5	#5647.20	64.2 PK	68.2	-4.0	2.16 H	3	62.50	1.70
6	#5972.80	57.2 PK	68.2	-11.0	2.16 H	3	54.50	2.70

ANTENNA POLARITY & TEST DISTANCE: VERTICAL AT 3 M

NO.	FREQ. (MHz)	EMISSION LEVEL (dBuV/m)	LIMIT (dBuV/m)	MARGIN (dB)	ANTENNA HEIGHT (m)	TABLE ANGLE (Degree)	RAW VALUE (dBuV)	CORRECTION FACTOR (dB/m)
1	*5755.00	116.2 PK			2.22 V	349	76.30	39.90
2	*5755.00	106.0 AV			2.22 V	349	66.10	39.90
3	11510.00	60.5 PK	74.0	-13.5	2.59 V	360	46.00	14.50
4	11510.00	47.3 AV	54.0	-6.7	2.59 V	360	32.80	14.50
5	#5649.60	59.4 PK	68.2	-8.8	2.22 V	349	57.70	1.70
6	#5978.40	57.0 PK	68.2	-11.2	2.22 V	349	54.20	2.80

REMARKS:

1. Emission Level(dBuV/m) = Raw Value(dBuV) + Correction Factor(dB/m)
2. Correction Factor(dB/m) = Antenna Factor(dB/m) + Cable Factor(dB)
3. The other emission levels were very low against the limit.
4. Margin value = Emission Level – Limit value
5. " * ": Fundamental frequency.
6. " # ": The radiated frequency is out of the restricted band.

CHANNEL	TX Channel 159	DETECTOR FUNCTION	Peak (PK)
FREQUENCY RANGE	1GHz ~ 40GHz		Average (AV)

ANTENNA POLARITY & TEST DISTANCE: HORIZONTAL AT 3 M

NO.	FREQ. (MHz)	EMISSION LEVEL (dBuV/m)	LIMIT (dBuV/m)	MARGIN (dB)	ANTENNA HEIGHT (m)	TABLE ANGLE (Degree)	RAW VALUE (dBuV)	CORRECTION FACTOR (dB/m)
1	*5795.00	121.3 PK			2.10 H	0	81.20	40.10
2	*5795.00	111.0 AV			2.10 H	0	70.90	40.10
3	11590.00	61.4 PK	74.0	-12.6	2.18 H	358	47.10	14.30
4	11590.00	47.8 AV	54.0	-6.2	2.18 H	358	33.50	14.30
5	#5617.60	63.5 PK	68.2	-4.7	2.10 H	0	61.80	1.70
6	#5983.20	62.8 PK	68.2	-5.4	2.10 H	0	60.00	2.80

ANTENNA POLARITY & TEST DISTANCE: VERTICAL AT 3 M

NO.	FREQ. (MHz)	EMISSION LEVEL (dBuV/m)	LIMIT (dBuV/m)	MARGIN (dB)	ANTENNA HEIGHT (m)	TABLE ANGLE (Degree)	RAW VALUE (dBuV)	CORRECTION FACTOR (dB/m)
1	*5795.00	116.7 PK			2.22 V	345	76.60	40.10
2	*5795.00	106.1 AV			2.22 V	345	66.00	40.10
3	11590.00	61.2 PK	74.0	-12.8	1.13 V	359	46.90	14.30
4	11590.00	48.1 AV	54.0	-5.9	1.13 V	359	33.80	14.30
5	#5623.20	57.5 PK	68.2	-10.7	2.22 V	345	55.80	1.70
6	#5992.80	56.8 PK	68.2	-11.4	2.22 V	345	54.00	2.80

REMARKS:

1. Emission Level(dBuV/m) = Raw Value(dBuV) + Correction Factor(dB/m)
2. Correction Factor(dB/m) = Antenna Factor(dB/m) + Cable Factor(dB)
3. The other emission levels were very low against the limit.
4. Margin value = Emission Level – Limit value
5. " * ": Fundamental frequency.
6. " # ": The radiated frequency is out of the restricted band.

802.11ac (VHT80)

CHANNEL	TX Channel 42	DETECTOR FUNCTION	Peak (PK)
FREQUENCY RANGE	1GHz ~ 40GHz		Average (AV)

ANTENNA POLARITY & TEST DISTANCE: HORIZONTAL AT 3 M								
NO.	FREQ. (MHz)	EMISSION LEVEL (dBuV/m)	LIMIT (dBuV/m)	MARGIN (dB)	ANTENNA HEIGHT (m)	TABLE ANGLE (Degree)	RAW VALUE (dBuV)	CORRECTION FACTOR (dB/m)
1	5150.00	60.9 PK	74.0	-13.1	2.21 H	353	60.10	0.80
2	5150.00	47.0 AV	54.0	-7.0	2.21 H	353	46.20	0.80
3	*5210.00	102.4 PK			1.71 H	345	63.70	38.70
4	*5210.00	91.7 AV			1.71 H	345	53.00	38.70
5	#10420.00	56.5 PK	74.0	-17.5	1.59 H	318	43.60	12.90
6	#10420.00	43.6 AV	54.0	-10.4	1.59 H	318	30.70	12.90

ANTENNA POLARITY & TEST DISTANCE: VERTICAL AT 3 M								
NO.	FREQ. (MHz)	EMISSION LEVEL (dBuV/m)	LIMIT (dBuV/m)	MARGIN (dB)	ANTENNA HEIGHT (m)	TABLE ANGLE (Degree)	RAW VALUE (dBuV)	CORRECTION FACTOR (dB/m)
1	5150.00	61.8 PK	74.0	-12.2	1.51 V	0	61.00	0.80
2	5150.00	46.6 AV	54.0	-7.4	1.51 V	0	45.80	0.80
3	*5210.00	100.5 PK			1.26 V	148	61.80	38.70
4	*5210.00	90.4 AV			1.26 V	148	51.70	38.70
5	#10420.00	57.7 PK	74.0	-16.3	1.33 V	124	44.80	12.90
6	#10420.00	44.1 AV	54.0	-9.9	1.33 V	124	31.20	12.90

REMARKS:

1. Emission Level(dBuV/m) = Raw Value(dBuV) + Correction Factor(dB/m)
2. Correction Factor(dB/m) = Antenna Factor(dB/m) + Cable Factor(dB)
3. The other emission levels were very low against the limit.
4. Margin value = Emission Level – Limit value
5. " * ": Fundamental frequency.
6. " # ": The radiated frequency is out of the restricted band.

CHANNEL	TX Channel 155	DETECTOR FUNCTION	Peak (PK)
FREQUENCY RANGE	1GHz ~ 40GHz		Average (AV)

ANTENNA POLARITY & TEST DISTANCE: HORIZONTAL AT 3 M

NO.	FREQ. (MHz)	EMISSION LEVEL (dBuV/m)	LIMIT (dBuV/m)	MARGIN (dB)	ANTENNA HEIGHT (m)	TABLE ANGLE (Degree)	RAW VALUE (dBuV)	CORRECTION FACTOR (dB/m)
1	#5650.00	66.4 PK	68.2	-1.8	2.10 H	11	64.70	1.70
2	#5925.00	64.6 PK	68.2	-3.6	1.95 H	360	62.00	2.60
3	*5775.00	113.9 PK			1.98 H	0	73.90	40.00
4	*5775.00	105.7 AV			1.98 H	0	65.70	40.00
5	11550.00	60.6 PK	74.0	-13.4	1.27 H	330	46.10	14.50
6	11550.00	47.5 AV	54.0	-6.5	1.27 H	330	33.00	14.50
7	#5640.00	65.6 PK	68.2	-2.6	1.98 H	0	63.90	1.70
8	#5927.20	61.7 PK	68.2	-6.5	1.98 H	0	59.10	2.60

ANTENNA POLARITY & TEST DISTANCE: VERTICAL AT 3 M

NO.	FREQ. (MHz)	EMISSION LEVEL (dBuV/m)	LIMIT (dBuV/m)	MARGIN (dB)	ANTENNA HEIGHT (m)	TABLE ANGLE (Degree)	RAW VALUE (dBuV)	CORRECTION FACTOR (dB/m)
1	#5650.00	64.8 PK	68.2	-3.4	1.81 V	360	63.10	1.70
2	#5925.00	60.9 PK	68.2	-7.3	2.22 V	326	58.30	2.60
3	*5775.00	111.5 PK			1.85 V	320	71.50	40.00
4	*5775.00	101.2 AV			1.85 V	320	61.20	40.00
5	11550.00	59.2 PK	74.0	-14.8	1.41 V	321	44.70	14.50
6	11550.00	46.1 AV	54.0	-7.9	1.41 V	321	31.60	14.50
7	#5649.60	63.6 PK	68.2	-4.6	1.85 V	320	61.90	1.70
8	#5945.60	56.7 PK	68.2	-11.5	1.85 V	320	54.10	2.60

REMARKS:

1. Emission Level(dBuV/m) = Raw Value(dBuV) + Correction Factor(dB/m)
2. Correction Factor(dB/m) = Antenna Factor(dB/m) + Cable Factor(dB)
3. The other emission levels were very low against the limit.
4. Margin value = Emission Level – Limit value
5. " * ": Fundamental frequency.
6. " # ": The radiated frequency is out of the restricted band.

Below 1GHz Worst-Case Data: 802.11a

CHANNEL	TX Channel 157	DETECTOR FUNCTION	Quasi-Peak (QP)
FREQUENCY RANGE	9kHz ~ 1GHz		

ANTENNA POLARITY & TEST DISTANCE: HORIZONTAL AT 3 M

NO.	FREQ. (MHz)	EMISSION LEVEL (dBuV/m)	LIMIT (dBuV/m)	MARGIN (dB)	ANTENNA HEIGHT (m)	TABLE ANGLE (Degree)	RAW VALUE (dBuV)	CORRECTION FACTOR (dB/m)
1	39.62	26.6 QP	40.0	-13.4	2.00 H	80	41.80	-15.20
2	152.39	31.1 QP	43.5	-12.4	2.00 H	97	44.90	-13.80
3	245.72	37.9 QP	46.0	-8.1	1.01 H	121	52.00	-14.10
4	624.85	32.1 QP	46.0	-13.9	1.51 H	145	36.90	-4.80
5	829.00	37.2 QP	46.0	-8.8	1.51 H	294	38.20	-1.00
6	900.94	36.9 QP	46.0	-9.1	1.51 H	105	36.70	0.20

ANTENNA POLARITY & TEST DISTANCE: VERTICAL AT 3 M

NO.	FREQ. (MHz)	EMISSION LEVEL (dBuV/m)	LIMIT (dBuV/m)	MARGIN (dB)	ANTENNA HEIGHT (m)	TABLE ANGLE (Degree)	RAW VALUE (dBuV)	CORRECTION FACTOR (dB/m)
1	39.93	34.8 QP	40.0	-5.2	1.00 V	293	50.00	-15.20
2	148.50	32.9 QP	43.5	-10.6	1.00 V	178	46.70	-13.80
3	237.94	39.3 QP	46.0	-6.7	1.99 V	151	54.00	-14.70
4	599.58	31.1 QP	46.0	-14.9	1.00 V	42	36.50	-5.40
5	836.78	37.8 QP	46.0	-8.2	1.49 V	11	38.70	-0.90
6	900.94	39.0 QP	46.0	-7.0	1.99 V	4	38.80	0.20

REMARKS:

1. Emission Level(dBuV/m) = Raw Value(dBuV) + Correction Factor(dB/m)
2. Correction Factor(dB/m) = Antenna Factor(dB/m) + Cable Factor(dB)
3. The other emission levels were very low against the limit.
4. Margin value = Emission Level – Limit value

4.2 Conducted Emission Measurement

4.2.1 Limits of Conducted Emission Measurement

Frequency (MHz)	Conducted Limit (dBuV)	
	Quasi-peak	Average
0.15 - 0.5	66 - 56	56 - 46
0.50 - 5.0	56	46
5.0 - 30.0	60	50

Note: 1. The lower limit shall apply at the transition frequencies.

2. The limit decreases in line with the logarithm of the frequency in the range of 0.15 to 0.50MHz.

4.2.2 Test Instruments

Description & Manufacturer	Model No.	Serial No.	Cal. Date	Cal. Due
Test Receiver ROHDE & SCHWARZ	ESCI	100613	Nov. 21, 2016	Nov. 20, 2017
RF signal cable (with 10dB PAD) Woken	5D-FB	Cable-cond1-01	Dec. 22, 2016	Dec. 21, 2017
LISN ROHDE & SCHWARZ (EUT)	ESH3-Z5	835239/001	Mar. 10, 2017	Mar. 09, 2018
LISN ROHDE & SCHWARZ (Peripheral)	ESH3-Z5	100311	Jul. 28, 2016	Jul. 27, 2017
Software ADT	BV ADT_Cond_ V7.3.7.3	NA	NA	NA

Note: 1. The calibration interval of the above test instruments is 12 months and the calibrations are traceable to NML/ROC and NIST/USA.

2. The test was performed in HwaYa Shielded Room 1.

3. The VCCI Site Registration No. is C-2040.

4.2.3 Test Procedure

- The EUT was placed 0.4 meters from the conducting wall of the shielded room with EUT being connected to the power mains through a line impedance stabilization network (LISN). Other support units were connected to the power mains through another LISN. The two LISNs provide 50 ohm/ 50uH of coupling impedance for the measuring instrument.
- Both lines of the power mains connected to the EUT were checked for maximum conducted interference.
- The frequency range from 150kHz to 30MHz was searched. Emission levels under (Limit - 20dB) was not recorded.

NOTE: The resolution bandwidth and video bandwidth of test receiver is 9kHz for quasi-peak detection (QP) and average detection (AV) at frequency 0.15MHz-30MHz.

4.2.4 Deviation from Test Standard

No deviation.

4.2.5 Test Setup

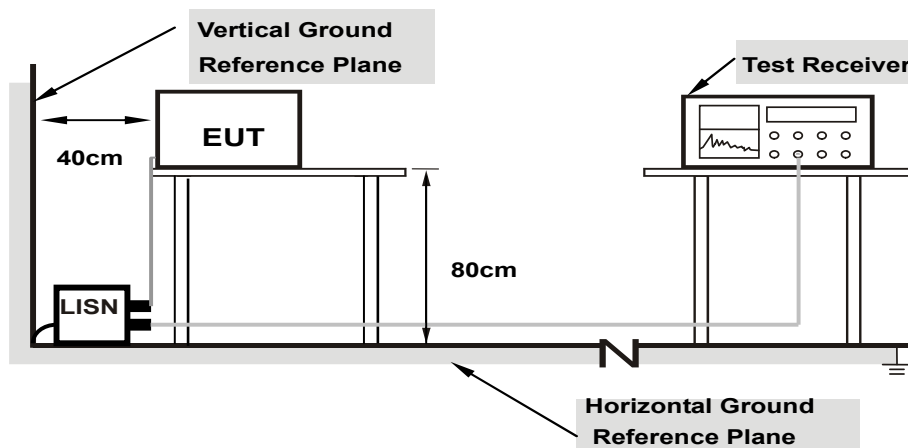

- Note:**
- Support units were connected to second LISN.
 - Both of LISNs (AMN) are 80 cm from EUT and at least 80 from other units and other metal planes

For the actual test configuration, please refer to the attached file (Test Setup Photo).

4.2.6 EUT Operating Conditions

Same as 4.1.6.

4.2.7 Test Results

Phase	Line (L)	Detector Function	Quasi-Peak (QP) / Average (AV)
-------	----------	-------------------	--------------------------------

No	Freq. [MHz]	Corr. Factor (dB)	Reading Value [dB (uV)]		Emission Level [dB (uV)]		Limit [dB (uV)]		Margin (dB)	
			Q.P.	AV.	Q.P.	AV.	Q.P.	AV.	Q.P.	AV.
	1	0.16600	10.41	35.88	21.51	46.29	31.92	65.16	55.16	-18.87
2	0.20523	10.43	30.36	16.43	40.79	26.86	63.40	53.40	-22.61	-26.54
3	0.47060	10.50	33.40	28.47	43.90	38.97	56.50	46.50	-12.60	-7.53
4	0.97800	10.46	22.38	19.00	32.84	29.46	56.00	46.00	-23.16	-16.54
5	1.59793	10.50	23.22	19.89	33.72	30.39	56.00	46.00	-22.28	-15.61
6	13.30600	11.07	17.42	12.51	28.49	23.58	60.00	50.00	-31.51	-26.42

REMARKS:

1. Q.P. and AV. are abbreviations of quasi-peak and average individually.
2. The emission levels of other frequencies were very low against the limit.
3. Margin value = Emission level - Limit value
4. Correction factor = Insertion loss + Cable loss
5. Emission Level = Correction Factor + Reading Value.

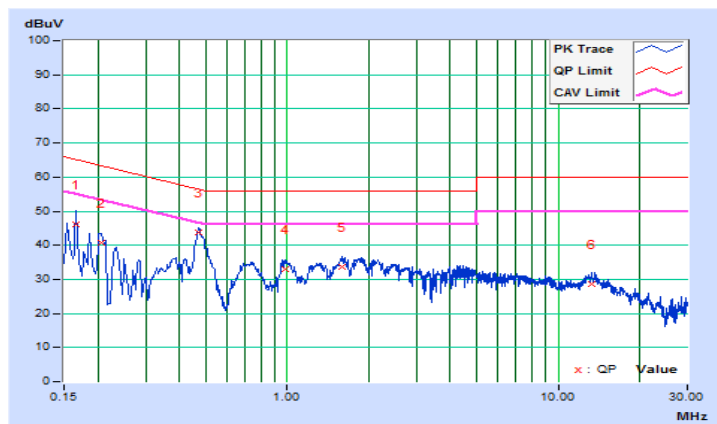

Phase	Neutral (N)	Detector Function	Quasi-Peak (QP) / Average (AV)
-------	-------------	-------------------	--------------------------------

No	Freq. [MHz]	Corr. Factor (dB)	Reading Value		Emission Level		Limit		Margin	
			[dB (uV)]		[dB (uV)]		[dB (uV)]		(dB)	
			Q.P.	AV.	Q.P.	AV.	Q.P.	AV.	Q.P.	AV.
1	0.17384	10.18	35.31	20.94	45.49	31.12	64.77	54.77	-19.28	-23.65
2	0.21400	10.20	29.16	14.77	39.36	24.97	63.05	53.05	-23.69	-28.08
3	0.46444	10.23	31.96	27.22	42.19	37.45	56.61	46.61	-14.42	-9.16
4	1.01034	10.24	20.60	17.63	30.84	27.87	56.00	46.00	-25.16	-18.13
5	3.09400	10.37	17.32	11.76	27.69	22.13	56.00	46.00	-28.31	-23.87
6	14.08600	10.80	15.25	10.29	26.05	21.09	60.00	50.00	-33.95	-28.91

REMARKS:

1. Q.P. and AV. are abbreviations of quasi-peak and average individually.
2. The emission levels of other frequencies were very low against the limit.
3. Margin value = Emission level - Limit value
4. Correction factor = Insertion loss + Cable loss
5. Emission Level = Correction Factor + Reading Value.

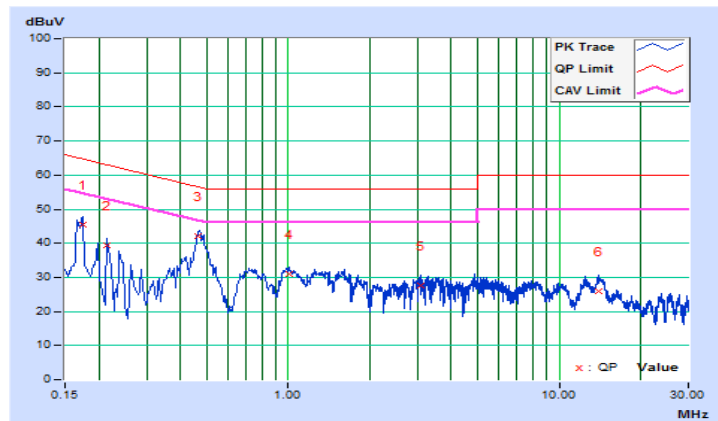

4.3 Transmit Power Measurement

4.3.1 Limits of Transmit Power Measurement

Operation Band	EUT Category		LIMIT
U-NII-1	√	Outdoor Access Point	1 Watt (30 dBm) (Max. e.i.r.p ≤ 125mW(21 dBm) at any elevation angle above 30 degrees as measured from the horizon)
	---	Fixed point-to-point Access Point	1 Watt (30 dBm)
	---	Indoor Access Point	1 Watt (30 dBm)
	---	Mobile and Portable client device	250mW (24 dBm)
U-NII-2A	---		250mW (24 dBm) or 11 dBm+10 log B*
U-NII-2C	---		250mW (24 dBm) or 11 dBm+10 log B*
U-NII-3	√		1 Watt (30 dBm)

*B is the 26 dB emission bandwidth in megahertz

Per KDB 662911 Method of conducted output power measurement on IEEE 802.11 devices,

Array Gain = 0 dB (i.e., no array gain) for $N_{ANT} \leq 4$;

Array Gain = 0 dB (i.e., no array gain) for channel widths ≥ 40 MHz for any N_{ANT} ;

Array Gain = $5 \log(N_{ANT}/N_{SS})$ dB or 3 dB, whichever is less for 20-MHz channel widths with $N_{ANT} \geq 5$.

For power measurements on all other devices: Array Gain = $10 \log(N_{ANT}/N_{SS})$ dB.

4.3.2 Test Setup

For Power Output Measurement

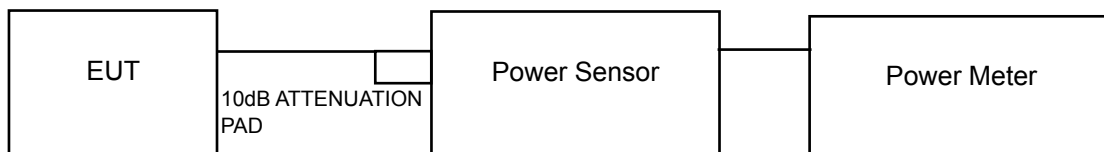

For 26dB Bandwidth

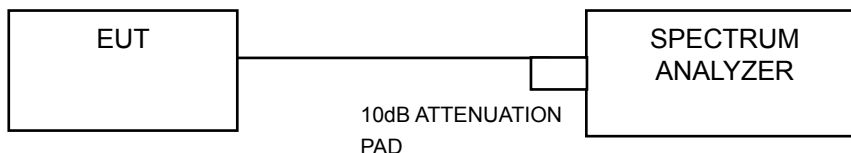

4.3.3 Test Instruments

Refer to section 4.1.2 to get information of above instrument.

4.3.4 Test Procedure

FOR AVERAGE POWER MEASUREMENT

For 802.11a, 802.11n (HT20), 802.11n (HT40)

Method PM is used to perform output power measurement, trigger and gating function of wide band power meter is enabled to measure max output power of TX on burst. Duty factor is not added to measured value.

For 802.11ac (VHT80)

- 1) Set span to encompass the entire 26 dB EBW (or, alternatively, the entire 99% occupied bandwidth) of the signal.
- 2) Set sweep trigger to "free run".
- 3) Set RBW = 1 MHz
- 4) Set VBW \geq 3 MHz
- 5) Number of points in sweep \geq 2 Span / RBW.
- 6) Sweep time \leq (number of points in sweep) * T
- 7) Using emission bandwidth to determine the frequency span for integration the channel bandwidth.
- 8) Detector = RMS.
- 9) Trace mode = max hold.
- 10) Allow max hold to run for at least 60 seconds, or longer as needed to allow the trace to stabilize.

FOR 26dB BANDWIDTH

- 1) Set RBW = approximately 1% of the emission bandwidth.
- 2) Set the VBW > RBW.
- 3) Detector = Peak.
- 4) Trace mode = max hold.
- 5) Measure the maximum width of the emission that is 26 dB down from the peak of the emission. Compare this with the RBW setting of the analyzer. Readjust RBW and repeat measurement as needed until the RBW/EBW ratio is approximately 1%.

4.3.5 Deviation from Test Standard

No deviation.

4.3.6 EUT Operating Conditions

The software provided by client to enable the EUT under transmission Condition continuously at lowest, middle and highest channel frequencies individually.

4.3.7 Test Result

POWER OUTPUT:

For U-NII-1 Band (Outdoor Access Point Mode)

802.11a

Chan.	Freq. (MHz)	Conducted Power (dBm)			Total Power (mW)	Total Power (dBm)	Gain (dBi)	EIRP (dBm)	EIRP limit (dBm)	Pass / Fail
		Chain 0	Chain 1	Chain 2						
36	5180	10.32	11.01	9.54	32.378	15.10	5.7	20.80	21.00	Pass
40	5200	10.15	10.88	9.20	30.915	14.90	5.7	20.60	21.00	Pass
48	5240	10.69	11.34	9.17	33.596	15.26	5.7	20.96	21.00	Pass

Note:

Gain = 5.7dBi,

EIRP = conducted power +(5.7dBi) + array gain = (0 dB (i.e., no array gain) for $N_{ANT} \leq 4$).

802.11n (HT20)

Chan.	Freq. (MHz)	Conducted Power (dBm)			Total Power (mW)	Total Power (dBm)	Gain (dBi)	EIRP (dBm)	EIRP limit (dBm)	Pass / Fail
		Chain 0	Chain 1	Chain 2						
36	5180	10.52	10.88	8.97	31.407	14.97	5.7	20.67	21.00	Pass
40	5200	10.01	11.10	9.20	31.223	14.94	5.7	20.64	21.00	Pass
48	5240	10.03	11.15	9.30	31.612	15.00	5.7	20.70	21.00	Pass

Note:

Gain = 5.7dBi,

EIRP = conducted power +(5.7dBi) + array gain = (0 dB (i.e., no array gain) for $N_{ANT} \leq 4$).

802.11n (HT40)

Chan.	Freq. (MHz)	Conducted Power (dBm)			Total Power (mW)	Total Power (dBm)	Gain (dBi)	EIRP (dBm)	EIRP limit (dBm)	Pass / Fail
		Chain 0	Chain 1	Chain 2						
38	5190	10.20	10.99	9.42	31.781	15.02	5.7	20.72	21.00	Pass
46	5230	10.35	10.85	8.83	30.639	14.86	5.7	20.56	21.00	Pass

Note:

Gain = 5.7dBi,

EIRP = conducted power +(5.7dBi) + array gain = (0 dB (i.e., no array gain) for $N_{ANT} \leq 4$).

802.11ac (VHT80)

Chan.	Freq. (MHz)	Conducted Power (dBm)			Total Power (mW)	Total Power (dBm)	Gain (dBi)	EIRP (dBm)	EIRP limit (dBm)	Pass / Fail
		Chain 0	Chain 1	Chain 2						
42	5210	10.44	10.96	9.15	31.762	15.02	5.7	20.72	21.00	Pass

Note:

Gain = 5.7dBi,

EIRP = conducted power +(5.7dBi) + array gain = (0 dB (i.e., no array gain) for $N_{ANT} \leq 4$).

For U-NII-3 Band

802.11a

Channel	Frequency (MHz)	Maximum Conducted Power (dBm)			Maximum Conducted Power (mW)	Maximum Conducted Power (dBm)	Power Limit (dBm)	Pass / Fail
		Chain 0	Chain 1	Chain 2				
149	5745	23.67	23.45	23.14	660.181	28.20	30	Pass
157	5785	22.54	23.54	22.46	581.615	27.65	30	Pass
165	5825	23.09	23.66	23.11	640.622	28.07	30	Pass

802.11n (HT20)

Channel	Frequency (MHz)	Maximum Conducted Power (dBm)			Maximum Conducted Power (mW)	Maximum Conducted Power (dBm)	Power Limit (dBm)	Pass / Fail
		Chain 0	Chain 1	Chain 2				
149	5745	23.00	23.34	21.18	546.520	27.38	30	Pass
157	5785	23.47	23.26	22.41	608.348	27.84	30	Pass
165	5825	23.68	23.80	23.17	680.720	28.33	30	Pass

802.11n (HT40)

Channel	Frequency (MHz)	Maximum Conducted Power (dBm)			Maximum Conducted Power (mW)	Maximum Conducted Power (dBm)	Power Limit (dBm)	Pass / Fail
		Chain 0	Chain 1	Chain 2				
151	5755	23.18	22.70	21.09	522.708	27.18	30	Pass
159	5795	23.30	22.47	21.33	526.231	27.21	30	Pass

802.11ac (VHT80)

Channel	Frequency (MHz)	Maximum Conducted Power (dBm)			Maximum Conducted Power (mW)	Maximum Conducted Power (dBm)	Power Limit (dBm)	Pass / Fail
		Chain 0	Chain 1	Chain 2				
155	5775	20.63	20.31	18.71	297.312	24.73	30	Pass

26dB BANDWIDTH:

802.11a

Channel	Frequency (MHz)	26dBc Bandwidth (MHz)			Pass / Fail
		Chain 0	Chain 1	Chain 2	
36	5180	23.44	22.55	22.67	Pass
40	5200	23.18	22.29	21.97	Pass
48	5240	22.83	21.92	22.44	Pass

802.11n (HT20)

Channel	Frequency (MHz)	26dBc Bandwidth (MHz)			Pass / Fail
		Chain 0	Chain 1	Chain 2	
36	5180	23.57	23.42	23.69	Pass
40	5200	23.55	23.62	23.11	Pass
48	5240	23.27	23.67	23.40	Pass

802.11n (HT40)

Channel	Frequency (MHz)	26dBc Bandwidth (MHz)			Pass / Fail
		Chain 0	Chain 1	Chain 2	
38	5190	47.70	46.45	45.25	Pass
46	5230	47.02	46.36	45.68	Pass

802.11ac (VHT80)

Channel	Frequency (MHz)	26dBc Bandwidth (MHz)			Pass / Fail
		Chain 0	Chain 1	Chain 2	
42	5210	90.14	88.61	87.71	Pass

SPECTRUM PLOT OF WORST VALUE

802.11a

802.11n (HT20)

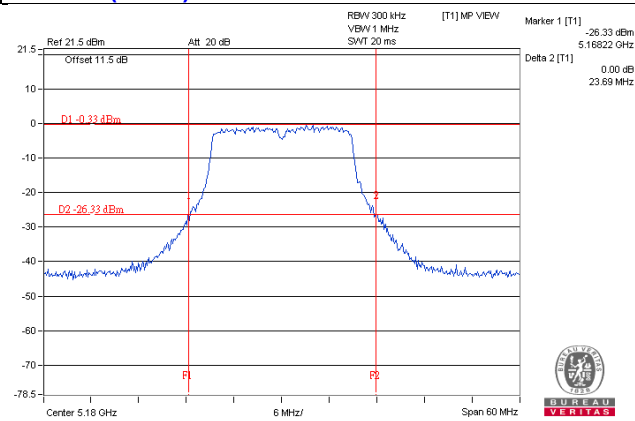
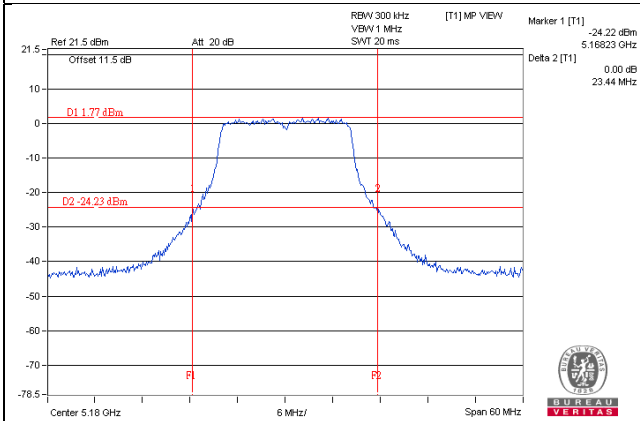

802.11n (HT40)

802.11ac (VHT80)

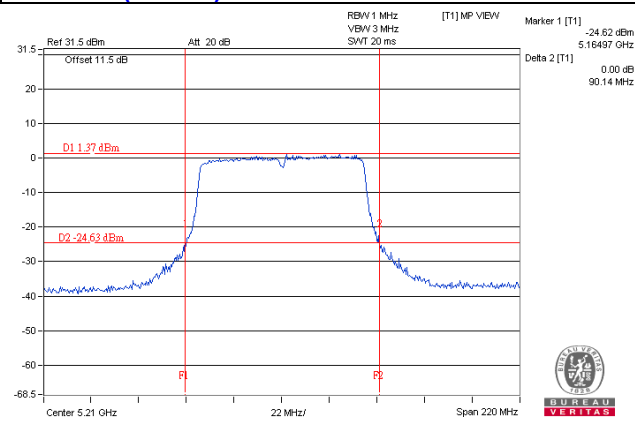
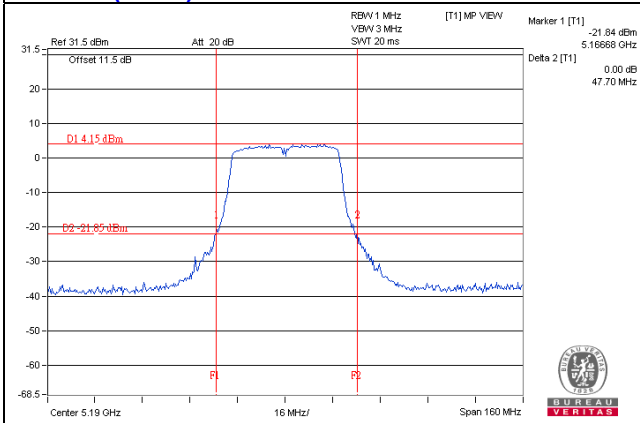

4.4 Occupied Bandwidth Measurement

4.4.1 Test Setup

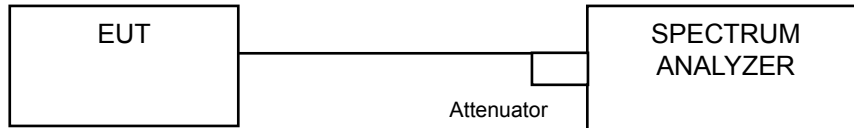

4.4.2 Test Instruments

Refer to section 4.1.2 to get information of above instrument.

4.4.3 Test Procedure

The transmitter output was connected to the spectrum analyzer through an attenuator. The bandwidth of the fundamental frequency was measured by spectrum analyzer with resolution bandwidth in the range of 1% to 5% of the anticipated emission bandwidth, and a video bandwidth at least 3x the resolution bandwidth and set the detector to SAMPLE. The width of a frequency band such that, below the lower and above the upper frequency limits, the mean powers emitted are each equal to a specified percentage 0.5 %of the total mean power of a given emission.

4.4.4 Test Results

802.11a

Channel	Frequency (MHz)	Occupied Bandwidth (MHz)		
		Chain 0	Chain 1	Chain 2
36	5180	16.80	16.80	16.80
40	5200	16.80	16.80	16.80
48	5240	16.80	16.80	16.80
149	5745	18.26	18.26	16.78
157	5785	18.60	18.84	16.80
165	5825	19.56	18.00	17.16

802.11n (HT20)

Channel	Frequency (MHz)	Occupied Bandwidth (MHz)		
		Chain 0	Chain 1	Chain 2
36	5180	18.00	17.88	17.88
40	5200	18.00	18.00	17.88
48	5240	18.00	18.00	17.88
149	5745	18.84	18.84	18.00
157	5785	19.32	18.96	18.00
165	5825	19.44	18.60	18.24

802.11n (HT40)

Channel	Frequency (MHz)	Occupied Bandwidth (MHz)		
		Chain 0	Chain 1	Chain 2
38	5190	36.72	36.84	36.96
46	5230	36.96	37.08	36.96
151	5755	37.32	37.44	37.08
159	5795	37.32	37.20	36.96

802.11ac (VHT80)

Channel	Frequency (MHz)	Occupied Bandwidth (MHz)		
		Chain 0	Chain 1	Chain 2
42	5210	76.08	76.08	76.08
155	5775	76.08	76.08	76.08

SPECTRUM PLOT OF WORST VALUE

802.11a

802.11n (HT20)

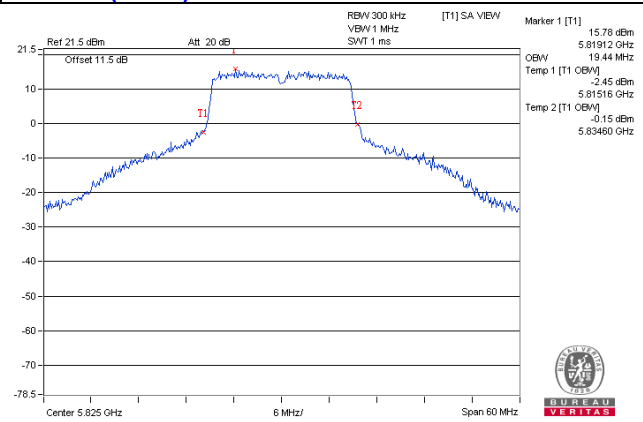
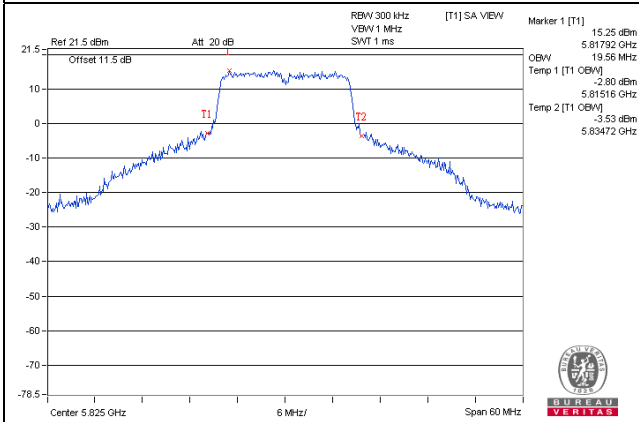

802.11n (HT40)

802.11a (VHT80)

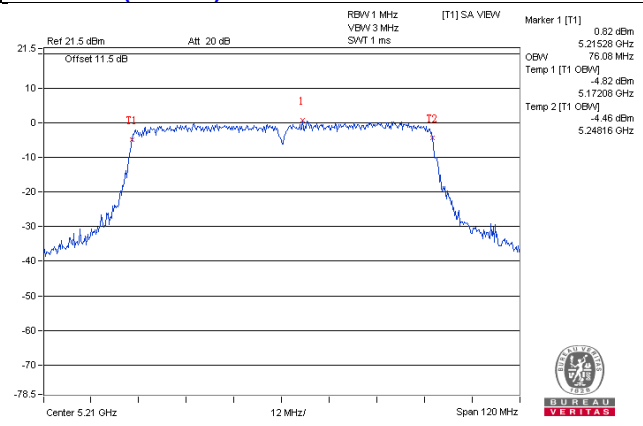
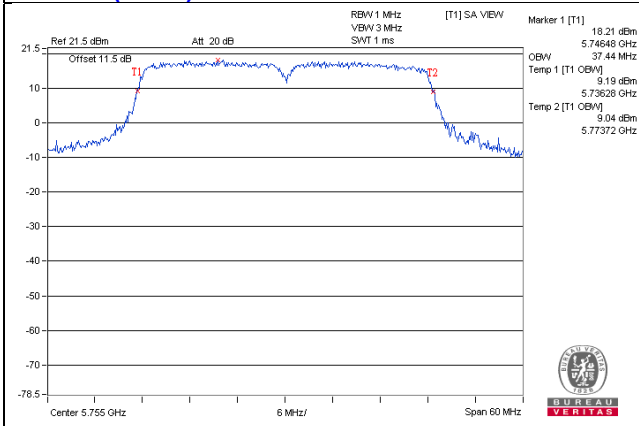

4.5 Peak Power Spectral Density Measurement

4.5.1 Limits of Peak Power Spectral Density Measurement

Operation Band	EUT Category		LIMIT
U-NII-1	√	Outdoor Access Point	17dBm/ MHz
	---	Fixed point-to-point Access Point	
	---	Indoor Access Point	
	---	Mobile and Portable client device	11dBm/ MHz
U-NII-2A	---		11dBm/ MHz
U-NII-2C	---		11dBm/ MHz
U-NII-3	√		30dBm/ 500kHz

4.5.2 Test Setup

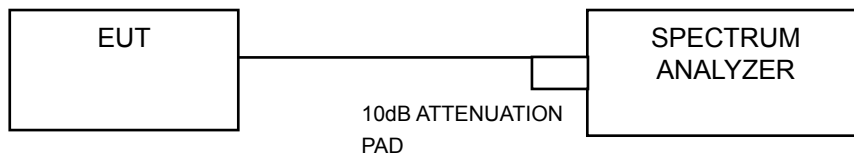

4.5.3 Test Instruments

Refer to section 4.1.2 to get information of above instrument.

4.5.4 Test Procedure

For U-NII-1 band:

Duty cycle of test signal is $\geq 98\%$

Using method SA-1

1. Set span to encompass the entire emission bandwidth (EBW) of the signal.
2. Set RBW = 30 kHz, Set VBW ≥ 1 MHz, Detector = RMS
3. Set Channel power measure = 1MHz
4. Sweep time = auto, trigger set to "free run".
5. Trace average at least 100 traces in power averaging mode.
6. Record the max value

Duty cycle of test signal is $< 98\%$

Using method SA-2

1. Set span to encompass the entire emission bandwidth (EBW) of the signal.
2. Set RBW = 30 kHz, Set VBW ≥ 1 MHz, Detector = RMS
3. Set Channel power measure = 1MHz
4. Sweep time = auto, trigger set to "free run".
5. Trace average at least 100 traces in power averaging mode.
6. Record the max value and add $10 \log(1/\text{duty cycle})$

For U-NII-3 band:

Duty cycle of test signal is $\geq 98\%$

1. Set span to encompass the entire emission bandwidth (EBW) of the signal.
2. Set RBW = 300 kHz, Set VBW ≥ 1 MHz, Detector = RMS
3. Use the peak marker function to determine the maximum power level in any 300 kHz band segment within the fundamental EBW.
4. Scale the observed power level to an equivalent value in 500 kHz by adjusting (reducing) the measured power by a bandwidth correction factor (BWCF) where $BWCF = 10 \log(500 \text{ kHz}/300 \text{ kHz})$
5. Sweep time = auto, trigger set to "free run".
6. Trace average at least 100 traces in power averaging mode.
7. Record the max value

Duty cycle of test signal is $< 98\%$

1. Set span to encompass the entire emission bandwidth (EBW) of the signal.
2. Set RBW = 300 kHz, Set VBW ≥ 1 MHz, Detector = RMS
3. Use the peak marker function to determine the maximum power level in any 300 kHz band segment within the fundamental EBW.
4. Scale the observed power level to an equivalent value in 500 kHz by adjusting (reducing) the measured power by a bandwidth correction factor (BWCF) where $BWCF = 10 \log(500 \text{ kHz}/300 \text{ kHz})$
5. Sweep time = auto, trigger set to "free run".
6. Trace average at least 100 traces in power averaging mode.
7. Record the max value and add $10 \log(1/\text{duty cycle})$

4.5.5 Deviation from Test Standard

No deviation.

4.5.6 EUT Operating Condition

Same as Item 4.3.6.

4.5.7 Test Results

For U-NII-1 Band (Outdoor Access Point Mode)

802.11a

Chan.	Frequency (MHz)	PSD (dBm/MHz)			Total PSD W/O Duty Factor (dBm/MHz)	Duty Factor	Total PSD With Duty Factor (dBm/MHz)	Maximum Limit (dBm/MHz)	Pass / Fail
		Chain 0	Chain 1	Chain 2					
36	5180	-2.96	-2.76	-4.31	1.48	0.19	1.67	12.68	Pass
40	5200	-3.17	-2.95	-5.02	1.15	0.19	1.34	12.68	Pass
48	5240	-2.88	-2.68	-5.03	1.36	0.19	1.55	12.68	Pass

Note:

- Method 1 of power density measurement of KDB 662911 is using for calculating total power density. Total power density is summing entire spectra across corresponding frequency bins on the various outputs by computer.
- For U-NII-1:** Directional gain = $10 \log[(10^{G1/20} + 10^{G2/20} + \dots + 10^{GN/20})^2/3] = 10.32\text{dBi} > 6\text{dBi}$, so the power density limit shall be reduced to $17 - (10.32 - 6) = 12.68\text{dBm}$.
- Refer to section 3.3 for duty cycle spectrum plot.

802.11n (HT20)

Chan.	Frequency (MHz)	PSD (dBm/MHz)			Total PSD W/O Duty Factor (dBm/MHz)	Duty Factor	Total PSD With Duty Factor (dBm/MHz)	Maximum Limit (dBm/MHz)	Pass / Fail
		Chain 0	Chain 1	Chain 2					
36	5180	-3.83	-3.84	-5.19	0.52	0.32	0.84	12.68	Pass
40	5200	-3.66	-3.42	-5.27	0.72	0.32	1.04	12.68	Pass
48	5240	-3.65	-3.14	-5.28	0.83	0.32	1.15	12.68	Pass

Note:

- Method 1 of power density measurement of KDB 662911 is using for calculating total power density. Total power density is summing entire spectra across corresponding frequency bins on the various outputs by computer.
- For U-NII-1:** Directional gain = $10 \log[(10^{G1/20} + 10^{G2/20} + \dots + 10^{GN/20})^2/3] = 10.32\text{dBi} > 6\text{dBi}$, so the power density limit shall be reduced to $17 - (10.32 - 6) = 12.68\text{dBm}$.
- Refer to section 3.3 for duty cycle spectrum plot.

802.11n (HT40)

Chan.	Frequency (MHz)	PSD (dBm/MHz)			Total PSD W/O Duty Factor (dBm/MHz)	Duty Factor	Total PSD With Duty Factor (dBm/MHz)	Maximum Limit (dBm/MHz)	Pass / Fail
		Chain 0	Chain 1	Chain 2					
38	5190	-6.63	-6.45	-8.32	-2.28	0.31	-1.97	12.68	Pass
46	5230	-6.86	-6.63	-8.74	-2.54	0.31	-2.23	12.68	Pass

Note:

- Method 1 of power density measurement of KDB 662911 is using for calculating total power density. Total power density is summing entire spectra across corresponding frequency bins on the various outputs by computer.
- For U-NII-1:** Directional gain = $10 \log[(10^{G1/20} + 10^{G2/20} + \dots + 10^{GN/20})^2/3] = 10.32\text{dBi} > 6\text{dBi}$, so the power density limit shall be reduced to $17 - (10.32 - 6) = 12.68\text{dBm}$.
- Refer to section 3.3 for duty cycle spectrum plot.

802.11ac (VHT80)

Chan.	Frequency (MHz)	PSD (dBm/MHz)			Total PSD (dBm/MHz)	Maximum Limit (dBm/MHz)	Pass / Fail
		Chain 0	Chain 1	Chain 2			
42	5210	-9.60	-9.40	-11.00	-5.17	12.68	Pass

Note:

- Method 1 of power density measurement of KDB 662911 is using for calculating total power density. Total power density is summing entire spectra across corresponding frequency bins on the various outputs by computer.
- For U-NII-1:** Directional gain = $10 \log[(10^{G1/20} + 10^{G2/20} + \dots + 10^{GN/20})^2/3] = 10.32\text{dBi} > 6\text{dBi}$, so the power density limit shall be reduced to $17 - (10.32 - 6) = 12.68\text{dBm}$.

SPECTRUM PLOT OF WORST VALUE

802.11a / CH 48 / Chain 1

802.11n (HT20) / CH 48 / Chain 1

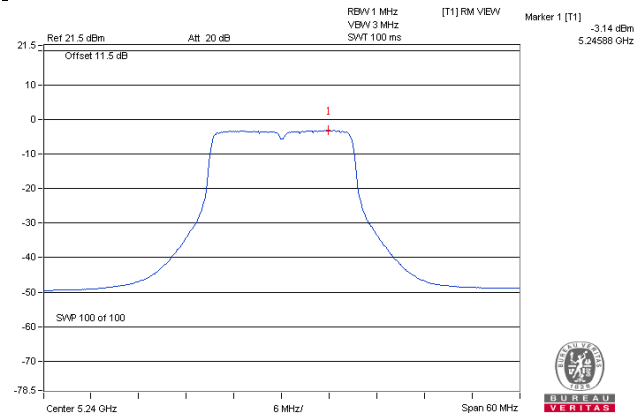
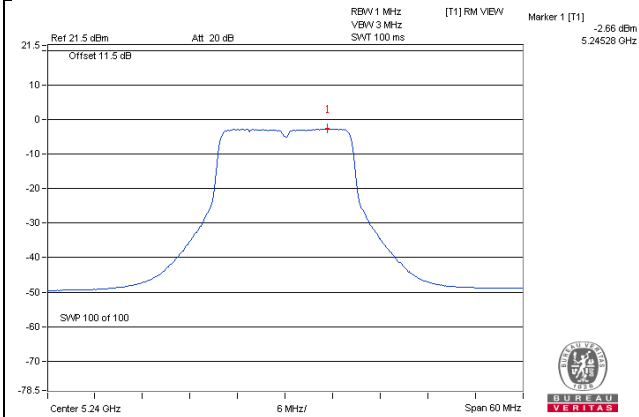

802.11n (HT40) / CH 38 / Chain 1

802.11ac (VHT80) / CH 42 / Chain 1

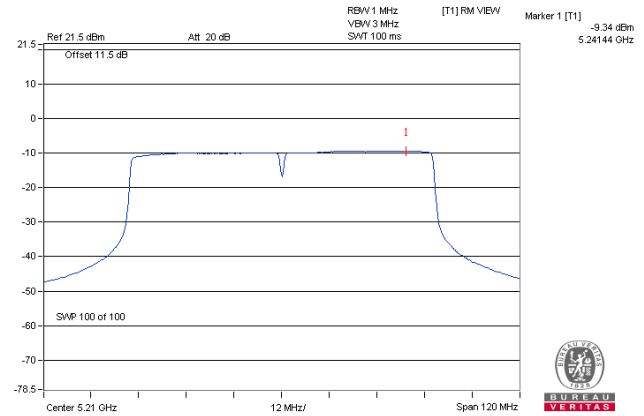
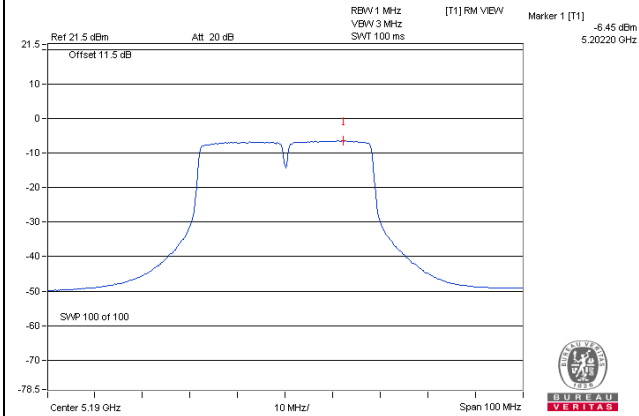

For U-NII-3 Band

802.11a

TX chain	Chan.	Freq. (MHz)	PSD W/O Duty Factor		10 log (N=3) dB	Duty Factor (dB)	Total PSD With Duty Factor (dBm/500kHz)	Limit (dBm/500kHz)	Pass / Fail
			(dBm/300kHz)	(dBm/500kHz)					
0	149	5745	2.93	5.15	4.77	0.19	10.11	25.53	Pass
	157	5785	3.07	5.29	4.77	0.19	10.25	25.53	Pass
	165	5825	3.12	5.34	4.77	0.19	10.30	25.53	Pass
1	149	5745	3.04	5.26	4.77	0.19	10.22	25.53	Pass
	157	5785	3.02	5.24	4.77	0.19	10.20	25.53	Pass
	165	5825	2.99	5.21	4.77	0.19	10.17	25.53	Pass
2	149	5745	0.48	2.70	4.77	0.19	7.66	25.53	Pass
	157	5785	1.40	3.62	4.77	0.19	8.58	25.53	Pass
	165	5825	2.12	4.34	4.77	0.19	9.30	25.53	Pass

Note:

- Method 1 of power density measurement of KDB 662911 is using for calculating total power density. Total power density is summing entire spectra across corresponding frequency bins on the various outputs by computer.
- For U-NII-3:** Directional gain = 5.70dBi + 10log(3) = 10.47dBi > 6dBi, so the power density limit shall be reduced to 30-(10.47-6) = 25.53dBm.
- Refer to section 3.3 for duty cycle spectrum plot.

802.11n (HT20)

TX chain	Chan.	Freq. (MHz)	PSD W/O Duty Factor		10 log (N=3) dB	Duty Factor (dB)	Total PSD With Duty Factor (dBm/500kHz)	Limit (dBm/500kHz)	Pass / Fail
			(dBm/300kHz)	(dBm/500kHz)					
0	149	5745	2.55	4.77	4.77	0.32	9.86	25.53	Pass
	157	5785	2.55	4.77	4.77	0.32	9.86	25.53	Pass
	165	5825	2.82	5.04	4.77	0.32	10.13	25.53	Pass
1	149	5745	2.73	4.95	4.77	0.32	10.04	25.53	Pass
	157	5785	2.81	5.03	4.77	0.32	10.12	25.53	Pass
	165	5825	2.27	4.49	4.77	0.32	9.58	25.53	Pass
2	149	5745	0.05	2.27	4.77	0.32	7.36	25.53	Pass
	157	5785	0.82	3.04	4.77	0.32	8.13	25.53	Pass
	165	5825	1.51	3.73	4.77	0.32	8.82	25.53	Pass

Note:

- Method 1 of power density measurement of KDB 662911 is using for calculating total power density. Total power density is summing entire spectra across corresponding frequency bins on the various outputs by computer.
- For U-NII-3:** Directional gain = $5.70\text{dBi} + 10\log(3) = 10.47\text{dBi} > 6\text{dBi}$, so the power density limit shall be reduced to $30 - (10.47 - 6) = 25.53\text{dBm}$.
- Refer to section 3.3 for duty cycle spectrum plot.

802.11n (HT40)

TX chain	Chan.	Freq. (MHz)	PSD W/O Duty Factor		10 log (N=3) dB	Duty Factor (dB)	Total PSD With Duty Factor (dBm/500kHz)	Limit (dBm/500kHz)	Pass / Fail
			(dBm/300kHz)	(dBm/500kHz)					
0	151	5755	-1.09	1.13	4.77	0.31	6.21	25.53	Pass
	159	5795	-1.24	0.98	4.77	0.31	6.06	25.53	Pass
1	151	5755	-1.18	1.04	4.77	0.31	6.12	25.53	Pass
	159	5795	-1.25	0.97	4.77	0.31	6.05	25.53	Pass
2	151	5755	-3.37	-1.15	4.77	0.31	3.93	25.53	Pass
	159	5795	-2.40	-0.18	4.77	0.31	4.90	25.53	Pass

Note:

- Method 1 of power density measurement of KDB 662911 is using for calculating total power density. Total power density is summing entire spectra across corresponding frequency bins on the various outputs by computer.
- For U-NII-3:** Directional gain = 5.70dBi + 10log(3) = 10.47dBi > 6dBi, so the power density limit shall be reduced to 30-(10.47-6) = 25.53dBm.
- Refer to section 3.3 for duty cycle spectrum plot.

802.11ac (VHT80)

TX chain	Chan.	Freq. (MHz)	PSD W/O Duty Factor		10 log (N=3) dB	Total PSD (dBm/500kHz)	Limit (dBm/500kHz)	Pass / Fail
			(dBm/300kHz)	(dBm/500kHz)				
0	155	5775	-6.70	-4.48	4.77	0.29	25.53	Pass
1	155	5775	-6.68	-4.46	4.77	0.31	25.53	Pass
2	155	5775	-8.71	-6.49	4.77	-1.72	25.53	Pass

Note:

- Method 1 of power density measurement of KDB 662911 is using for calculating total power density. Total power density is summing entire spectra across corresponding frequency bins on the various outputs by computer.
- For U-NII-3:** Directional gain = 5.70dBi + 10log(3) = 10.47dBi > 6dBi, so the power density limit shall be reduced to 30-(10.47-6) = 25.53dBm.

SPECTRUM PLOT OF WORST VALUE

802.11a

802.11n (HT20)

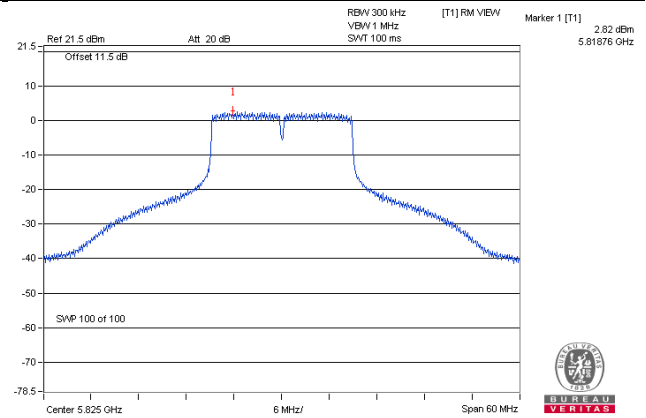
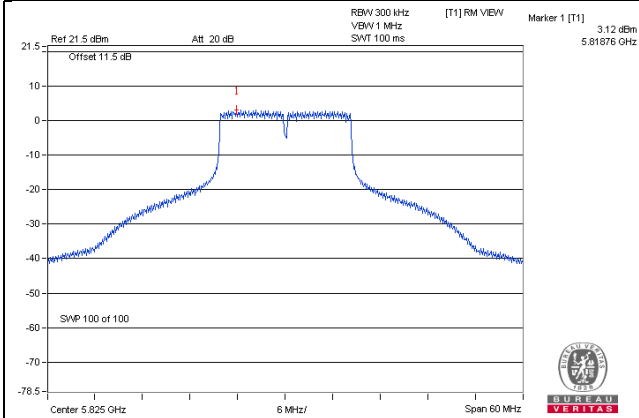

802.11n (HT40)

802.11ac (VHT80)

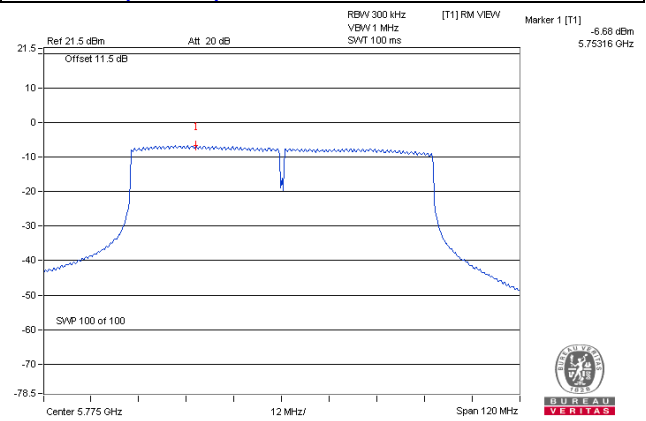
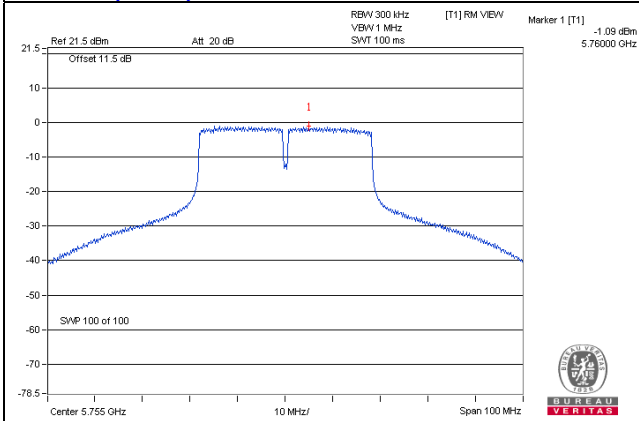

4.6 Frequency Stability

4.6.1 Limits of Frequency Stability Measurement

The frequency of the carrier signal shall be maintained within band of operation

4.6.2 Test Setup

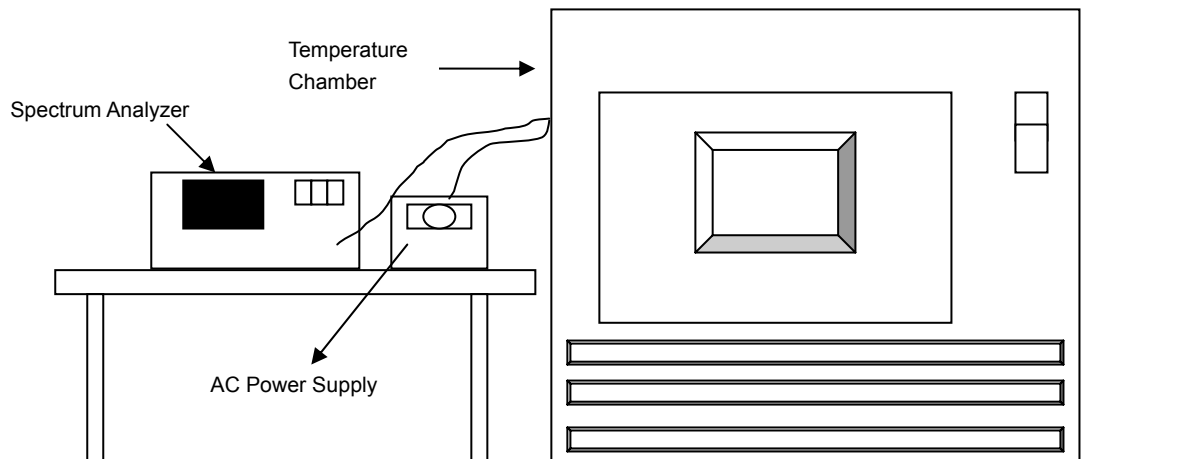

4.6.3 Test Instruments

Refer to section 4.1.2 to get information of above instrument.

4.6.4 Test Procedure

- The EUT was placed inside the environmental test chamber and powered by nominal AC voltage.
- Turn the EUT on and couple its output to a spectrum analyzer.
- Turn the EUT off and set the chamber to the highest temperature specified.
- Allow sufficient time (approximately 30 min) for the temperature of the chamber to stabilize, turn the EUT on and measure the operating frequency after 2, 5, and 10 minutes.
- Repeat step 2 and 3 with the temperature chamber set to the lowest temperature.
- The test chamber was allowed to stabilize at +20 degree C for a minimum of 30 minutes. The supply voltage was then adjusted on the EUT from 85% to 115% and the frequency record.

4.6.5 Deviation from Test Standard

No deviation.

4.6.6 EUT Operating Condition

Set the EUT transmit at un-modulation mode to test frequency stability.

4.6.7 Test Results

Frequency Stability Versus Temp.									
Operating Frequency: 5240MHz									
Temp. (°C)	Power Supply (Vac)	0 Minute		2 Minute		5 Minute		10 Minute	
		Measured Frequency (MHz)	Frequency Drift (%)	Measured Frequency (MHz)	Frequency Drift (%)	Measured Frequency (MHz)	Frequency Drift (%)	Measured Frequency (MHz)	Frequency Drift (%)
50	120	5240.0165	0.0003	5240.0154	0.0003	5240.0160	0.0003	5240.0155	0.0003
40	120	5240.0252	0.0005	5240.0228	0.0004	5240.0267	0.0005	5240.0238	0.0005
30	120	5239.9767	-0.0004	5239.9759	-0.0005	5239.9778	-0.0004	5239.9746	-0.0005
20	120	5239.9760	-0.0005	5239.9775	-0.0004	5239.9760	-0.0005	5239.9739	-0.0005
10	120	5240.0109	0.0002	5240.0123	0.0002	5240.0136	0.0003	5240.0127	0.0002
0	120	5239.9718	-0.0005	5239.9735	-0.0005	5239.9729	-0.0005	5239.9719	-0.0005
-10	120	5239.9971	-0.0001	5239.9959	-0.0001	5239.9958	-0.0001	5239.9974	-0.0001
-20	120	5240.0092	0.0002	5240.0089	0.0002	5240.0059	0.0001	5240.0082	0.0002
-30	120	5240.0169	0.0003	5240.0183	0.0004	5240.0192	0.0004	5240.0203	0.0004

Frequency Stability Versus Voltage									
Operating Frequency: 5240MHz									
Temp. (°C)	Power Supply (Vac)	0 Minute		2 Minute		5 Minute		10 Minute	
		Measured Frequency (MHz)	Frequency Drift (%)	Measured Frequency (MHz)	Frequency Drift (%)	Measured Frequency (MHz)	Frequency Drift (%)	Measured Frequency (MHz)	Frequency Drift (%)
20	138	5239.9751	-0.0005	5239.9765	-0.0005	5239.9767	-0.0004	5239.9747	-0.0005
	120	5239.9760	-0.0005	5239.9775	-0.0004	5239.9760	-0.0005	5239.9739	-0.0005
	102	5239.9755	-0.0005	5239.9775	-0.0004	5239.9761	-0.0005	5239.9731	-0.0005

4.7 6dB Bandwidth Measurement

4.7.1 Limits of 6dB Bandwidth Measurement

The minimum of 6dB Bandwidth Measurement is 0.5MHz.

4.7.2 Test Setup

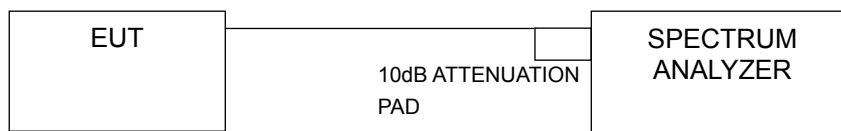

4.7.3 Test Instruments

Refer to section 4.1.2 to get information of above instrument.

4.7.4 Test Procedure

- a. Set resolution bandwidth (RBW) = 100kHz
- b. Set the video bandwidth (VBW) $\geq 3 \times$ RBW, Detector = Peak.
- c. Trace mode = max hold.
- d. Sweep = auto couple.
- e. Measure the maximum width of the emission that is constrained by the frequencies associated with the two amplitude points (upper and lower) that are attenuated by 6 dB relative to the maximum level measured in the fundamental emission

4.7.5 Deviation from Test Standard

No deviation.

4.7.6 EUT Operating Condition

The software provided by client to enable the EUT under transmission Condition continuously at lowest, middle and highest channel frequencies individually.

4.7.7 Test Results

802.11a

Channel	Frequency (MHz)	6dB Bandwidth (MHz)			Minimum Limit (MHz)	Pass / Fail
		Chain 0	Chain 1	Chain 2		
149	5745	16.39	16.40	16.42	0.5	Pass
157	5785	16.41	16.42	16.43	0.5	Pass
165	5825	16.39	16.41	16.43	0.5	Pass

802.11n (HT20)

Channel	Frequency (MHz)	6dB Bandwidth (MHz)			Minimum Limit (MHz)	Pass / Fail
		Chain 0	Chain 1	Chain 2		
149	5745	17.64	17.63	17.65	0.5	Pass
157	5785	17.63	17.63	17.65	0.5	Pass
165	5825	17.62	17.64	17.64	0.5	Pass

802.11n (HT40)

Channel	Frequency (MHz)	6dB Bandwidth (MHz)			Minimum Limit (MHz)	Pass / Fail
		Chain 0	Chain 1	Chain 2		
151	5755	36.46	35.87	36.43	0.5	Pass
159	5795	36.42	36.43	36.16	0.5	Pass

802.11ac (VHT80)

Channel	Frequency (MHz)	6dB Bandwidth (MHz)			Minimum Limit (MHz)	Pass / Fail
		Chain 0	Chain 1	Chain 2		
155	5775	76.48	76.53	76.38	0.5	Pass

SPECTRUM PLOT OF WORST VALUE

802.11a

802.11n (HT20)

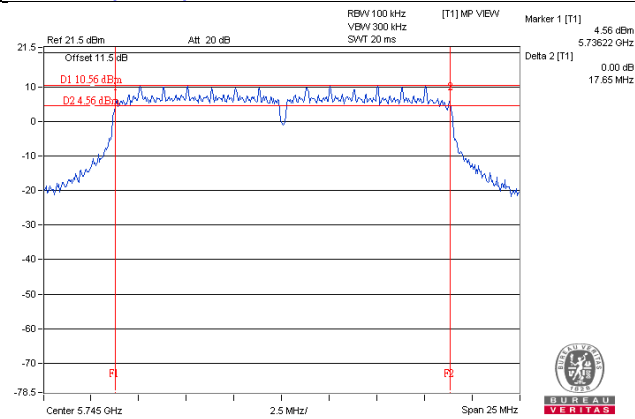
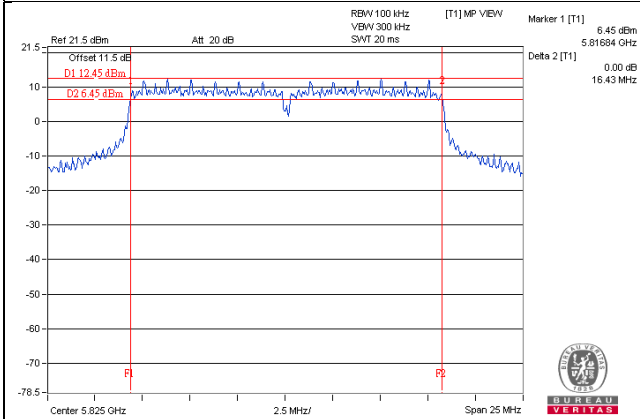

802.11n (HT40)

802.11ac (VHT80)

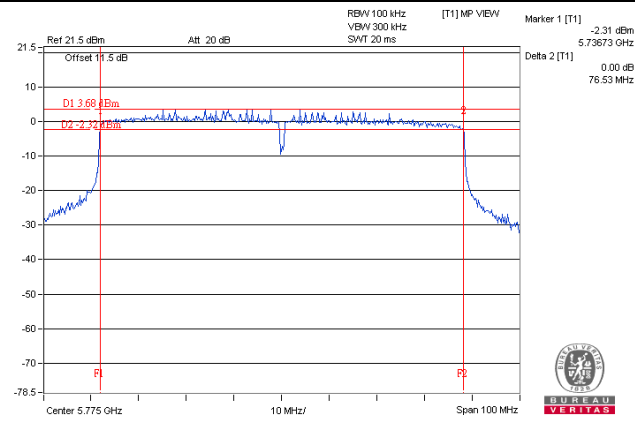
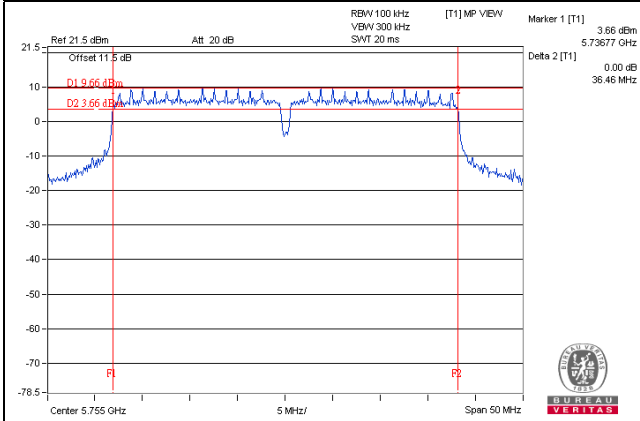

5 Pictures of Test Arrangements

Please refer to the attached file (Test Setup Photo).

Annex A- Radiated Out of Band Emission (OOBE) Measurement (For U-NII-3 band)

802.11a

CH149

Horizontal

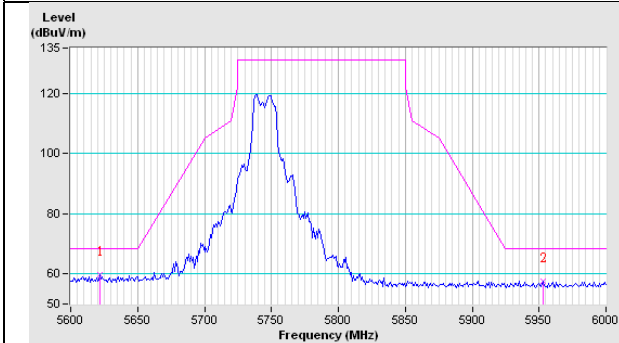

Vertical

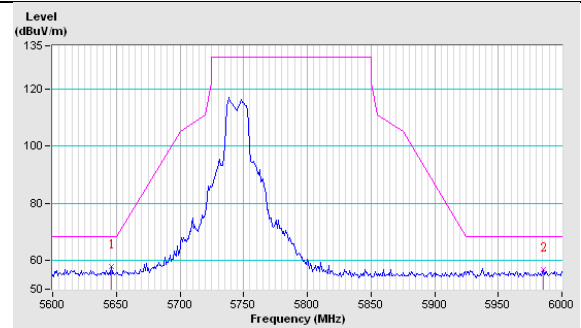

CH157

Horizontal

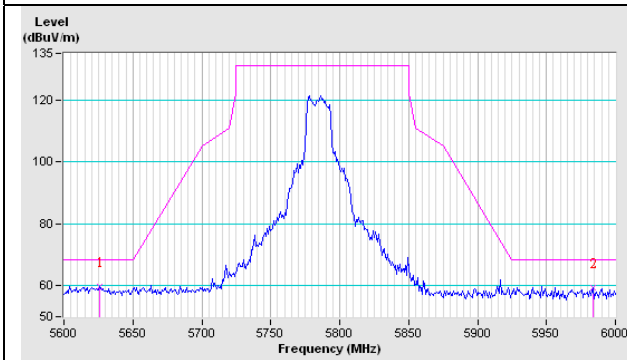

Vertical

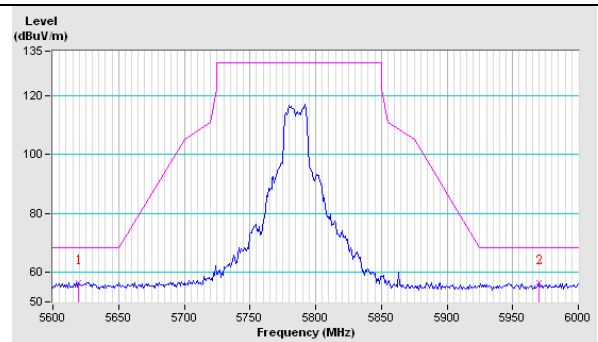

CH165

Horizontal

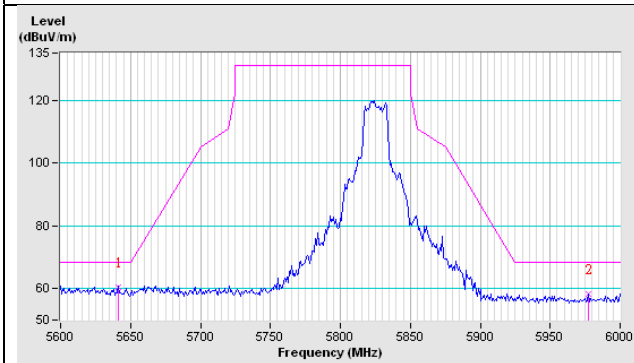

Vertical

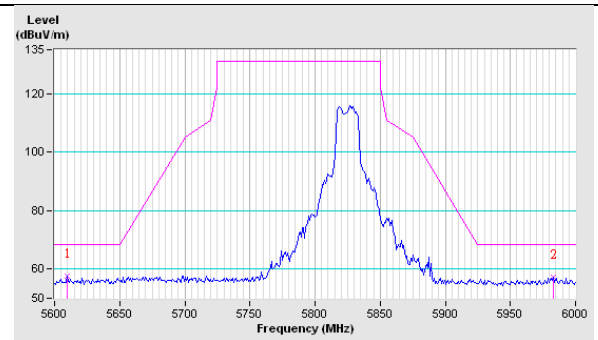

802.11n (HT20)

CH149

Horizontal

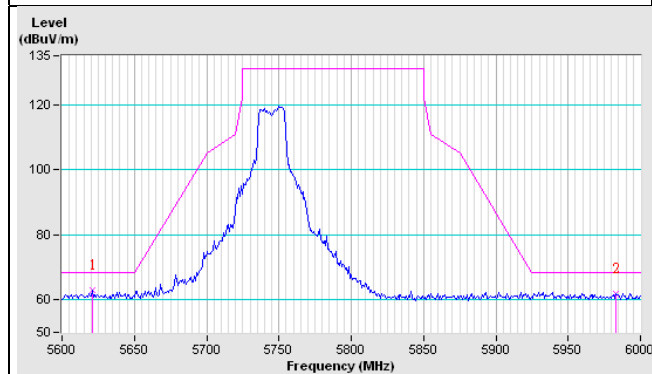

Vertical

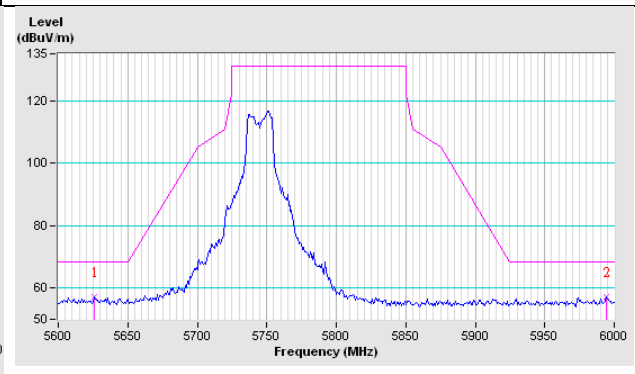

CH157

Horizontal

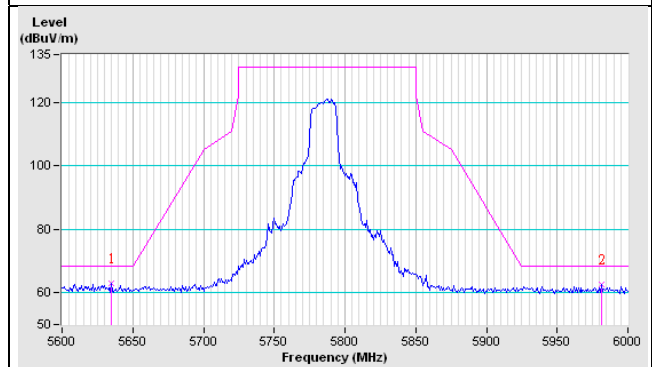

Vertical

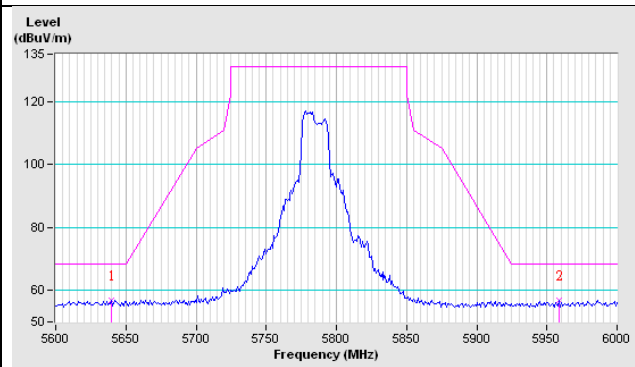

CH165

Horizontal

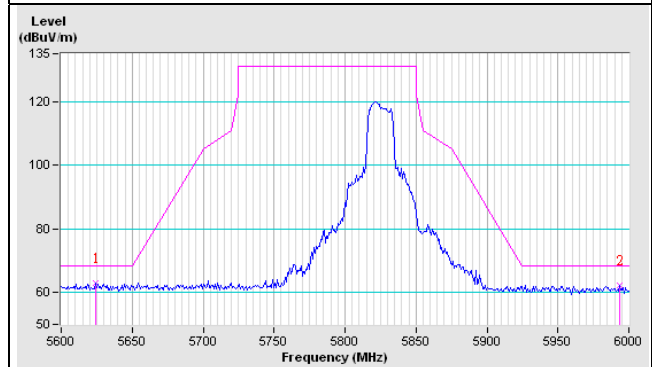

Vertical

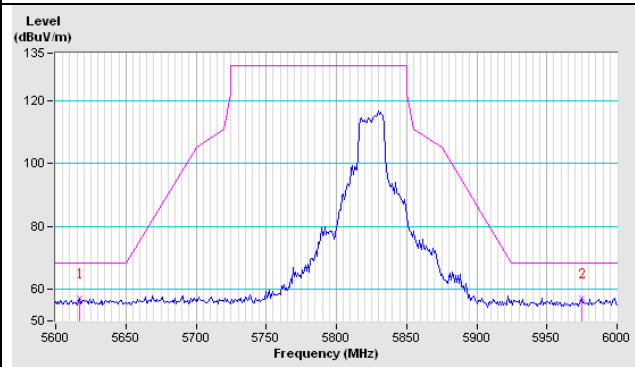

802.11n (HT40)

CH151

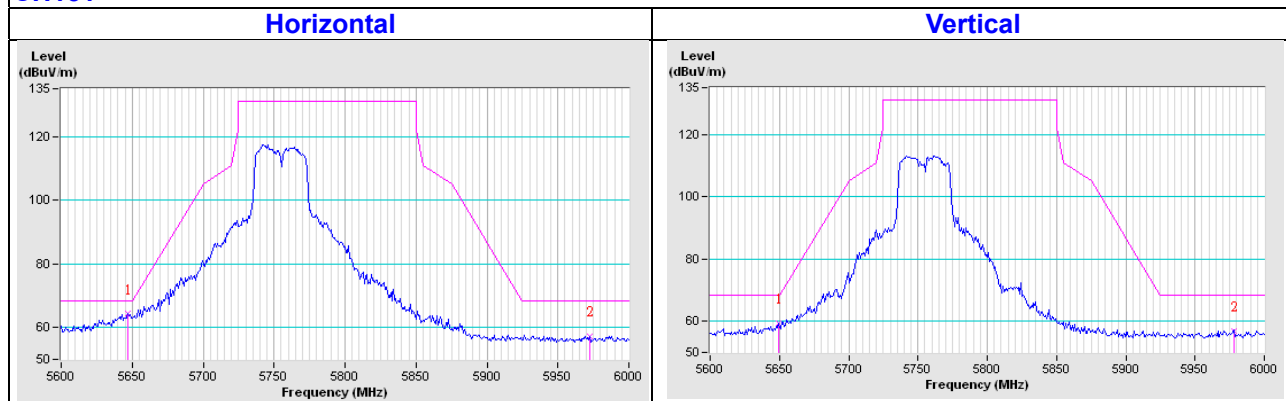

CH159

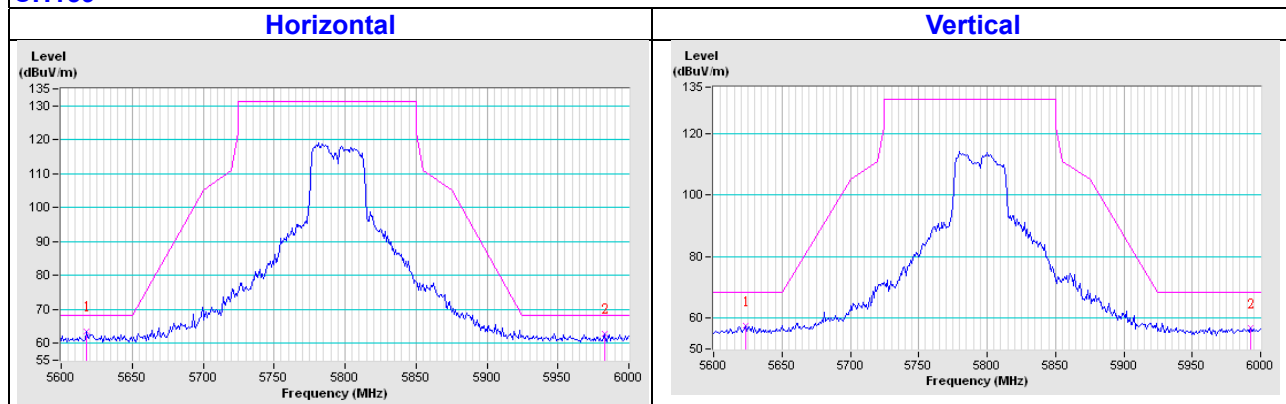

802.11ac (VHT80)

CH155

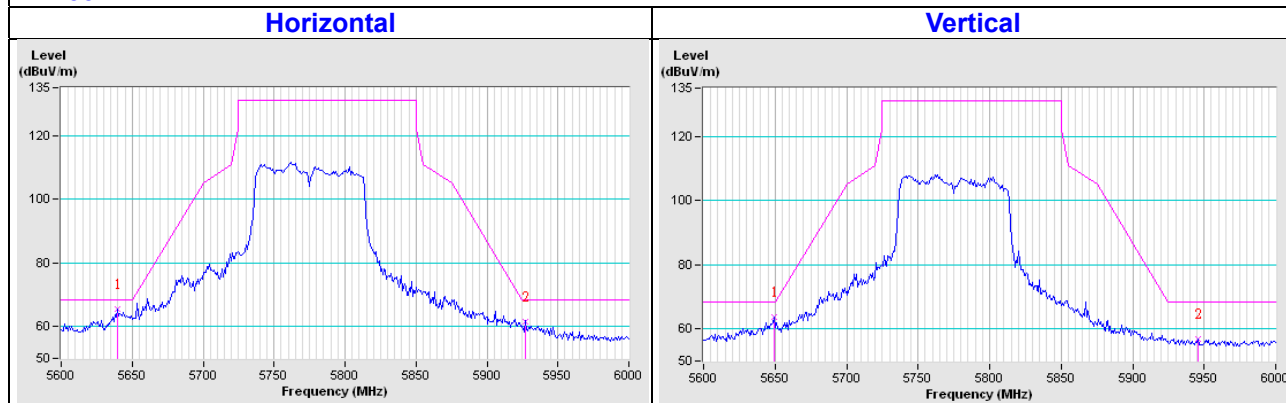

Appendix – Information on the Testing Laboratories

We, Bureau Veritas Consumer Products Services (H.K.) Ltd., Taoyuan Branch, were founded in 1988 to provide our best service in EMC, Radio, Telecom and Safety consultation. Our laboratories are accredited and approved according to ISO/IEC 17025.

If you have any comments, please feel free to contact us at the following:

Linko EMC/RF Lab

Tel: 886-2-26052180

Fax: 886-2-26051924

Hsin Chu EMC/RF/Telecom Lab

Tel: 886-3-5935343

Fax: 886-3-5935342

Hwa Ya EMC/RF/Safety Lab

Tel: 886-3-3183232

Fax: 886-3-3270892

Email: service.adt@tw.bureauveritas.com

Web Site: www.bureauveritas-adt.com

The address and road map of all our labs can be found in our web site also.

--- END ---