

FCC Test Report

Report No.: RF190627C01-1

FCC ID: 2AG6R-AN510APIWAC

Test Model: AN-510-AP-IW-AC

Received Date: Jun. 27, 2019

Test Date: Jul. 29 ~ Aug. 06, 2019

Issued Date: Aug. 19, 2019

Applicant: Araknis Networks

Address: 1800 Continental Blvd. Suite 300 Charlotte North Carolina United States

Issued By: Bureau Veritas Consumer Products Services (H.K.) Ltd., Taoyuan Branch

Lab Address: No. 47-2, 14th Ling, Chia Pau Vil., Lin Kou Dist., New Taipei City, Taiwan

Test Location: No. 19, Hwa Ya 2nd Rd., Wen Hwa Vil., Kwei Shan Dist., Taoyuan City
33383, Taiwan

**FCC Registration /
Designation Number:** 788550 / TW0003



This report is for your exclusive use. Any copying or replication of this report to or for any other person or entity, or use of our name or trademark, is permitted only with our prior written permission. This report sets forth our findings solely with respect to the test samples identified herein. The results set forth in this report are not indicative or representative of the quality or characteristics of the lot from which a test sample was taken or any similar or identical product specifically and expressly noted. Our report includes all of the tests requested by you and the results thereof based upon the information that you provided to us. You have 60 days from date of issuance of this report to notify us of any material error or omission caused by our negligence, provided, however, that such notice shall be in writing and shall specifically address the issue you wish to raise. A failure to raise such issue within the prescribed time shall constitute your unqualified acceptance of the completeness of this report, the tests conducted and the correctness of the report contents. Unless specific mention, the uncertainty of measurement has been explicitly taken into account to declare the compliance or non-compliance to the specification. The report must not be used by the client to claim product certification, approval, or endorsement by TAF or any government agencies.

Table of Contents

Release Control Record	4
1 Certificate of Conformity	5
2 Summary of Test Results	6
2.1 Measurement Uncertainty	6
2.2 Modification Record	6
3 General Information	7
3.1 General Description of EUT	7
3.2 Description of Test Modes	9
3.2.1 Test Mode Applicability and Tested Channel Detail	10
3.3 Duty Cycle of Test Signal	12
3.4 Description of Support Units	13
3.4.1 Configuration of System under Test	13
3.5 General Description of Applied Standards	14
4 Test Types and Results	15
4.1 Radiated Emission and Bandedge Measurement.....	15
4.1.1 Limits of Radiated Emission and Bandedge Measurement	15
4.1.2 Test Instruments	16
4.1.3 Test Procedures.....	17
4.1.4 Deviation from Test Standard	17
4.1.5 Test Setup.....	18
4.1.6 EUT Operating Conditions.....	19
4.1.7 Test Results	20
4.2 Conducted Emission Measurement	42
4.2.1 Limits of Conducted Emission Measurement	42
4.2.2 Test Instruments	42
4.2.3 Test Procedures.....	43
4.2.4 Deviation from Test Standard	43
4.2.5 Test Setup.....	43
4.2.6 EUT Operating Conditions.....	43
4.2.7 Test Results	44
4.3 Transmit Power Measurement	48
4.3.1 Limits of Transmit Power Measurement	48
4.3.2 Test Setup.....	48
4.3.3 Test Instruments	49
4.3.4 Test Procedure	49
4.3.5 Deviation from Test Standard	49
4.3.6 EUT Operating Conditions.....	49
4.3.7 Test Result.....	50
4.4 Occupied Bandwidth Measurement	52
4.4.1 Test Setup.....	52
4.4.2 Test Instruments	52
4.4.3 Test Procedure	52
4.4.4 Test Result.....	53
4.5 Peak Power Spectral Density Measurement	56
4.5.1 Limits of Peak Power Spectral Density Measurement	56
4.5.2 Test Setup.....	56
4.5.3 Test Instruments	56
4.5.4 Test Procedures.....	57
4.5.5 Deviation from Test Standard	57
4.5.6 EUT Operating Conditions.....	57
4.5.7 Test Results	58
4.6 Frequency Stability.....	63
4.6.1 Limits of Frequency Stability Measurement	63

4.6.2	Test Setup.....	63
4.6.3	Test Instruments	63
4.6.4	Test Procedure	63
4.6.5	Deviation from Test Standard	64
4.6.6	EUT Operating Condition	64
4.6.7	Test Results	64
4.7	6dB Bandwidth Measurement.....	65
4.7.1	Limits of 6dB Bandwidth Measurement.....	65
4.7.2	Test Setup.....	65
4.7.3	Test Instruments	65
4.7.4	Test Procedure	65
4.7.5	Deviation from Test Standard	65
4.7.6	EUT Operating Condition	65
4.7.7	Test Results	66
5	Pictures of Test Arrangements.....	68
	Annex A- Radiated Out of Band Emission (OOBE) Measurement (For U-NII-3 band).....	69
	Appendix – Information of the Testing Laboratories	72

Release Control Record

Issue No.	Description	Date Issued
RF190627C01-1	Original release.	Aug. 19, 2019

1 Certificate of Conformity

Product: Araknis Networks® 510-series Indoor Wall Mount Wireless Access Point

Brand: Araknis Networks

Test Model: AN-510-AP-IW-AC

Sample Status: Engineering sample

Applicant: Araknis Networks

Test Date: Jul. 29 ~ Aug. 06, 2019

Standards: 47 CFR FCC Part 15, Subpart E (Section 15.407)
ANSI C63.10:2013

The above equipment has been tested by **Bureau Veritas Consumer Products Services (H.K.) Ltd., Taoyuan Branch**, and found compliance with the requirement of the above standards. The test record, data evaluation & Equipment Under Test (EUT) configurations represented herein are true and accurate accounts of the measurements of the sample's RF characteristics under the conditions specified in this report.

Prepared by : Pettie Chen , **Date:** Aug. 19, 2019
Pettie Chen / Senior Specialist

Approved by : Bruce Chen , **Date:** Aug. 19, 2019
Bruce Chen / Senior Project Engineer

2 Summary of Test Results

47 CFR FCC Part 15, Subpart E (Section 15.407)			
FCC Clause	Test Item	Result	Remarks
15.407(b)(6)	AC Power Conducted Emissions	Pass	Meet the requirement of limit. Minimum passing margin is -4.33dB at 0.51312MHz.
15.407(b)(1/2/3/4(i/ii)/6)	Radiated Emissions & Band Edge Measurement	Pass	Meet the requirement of limit. Minimum passing margin is -0.2dB at 15600.00MHz.
15.407(a)(1/2/3)	Max Average Transmit Power	Pass	Meet the requirement of limit.
---	Occupied Bandwidth Measurement	Pass	Meet the requirement of limit.
15.407(a)(1/2/3)	Peak Power Spectral Density	Pass	Meet the requirement of limit. (U-NII-3 Band only)
15.407(e)	6dB bandwidth	Pass	Meet the requirement of limit.
15.407(g)	Frequency Stability	Pass	Meet the requirement of limit.
15.203	Antenna Requirement	Pass	Antenna connector is IPEX not a standard connector.

*For U-NII-3 band compliance with rule part 15.407(b)(4)(i), the OOB test plots were recorded in Annex A.
 Note: Determining compliance based on the results of the compliance measurement, not taking into account measurement instrumentation uncertainty.

2.1 Measurement Uncertainty

Where relevant, the following measurement uncertainty levels have been estimated for tests performed on the EUT as specified in CISPR 16-4-2:

Measurement	Frequency	Expanded Uncertainty (k=2) (±)
Conducted Emissions at mains ports	150kHz ~ 30MHz	2.94 dB
Radiated Emissions up to 1 GHz	9kHz ~ 30MHz	3.04 dB
	30MHz ~ 200MHz	3.86 dB
	200MHz ~ 1000MHz	3.87 dB
Radiated Emissions above 1 GHz	1GHz ~ 18GHz	2.29 dB
	18GHz ~ 40GHz	2.29 dB

2.2 Modification Record

There were no modifications required for compliance.

3 General Information

3.1 General Description of EUT

Product	Araknis Networks® 510-series Indoor Wall Mount Wireless Access Point
Brand	Araknis Networks
Test Model	AN-510-AP-IW-AC
Sample Status	Engineering sample
Power Supply Rating	48Vdc (adapter) 54Vdc (PoE)
Modulation Type	256QAM, 64QAM, 16QAM, QPSK, BPSK
Modulation Technology	OFDM
Transfer Rate	802.11a: 54/48/36/24/18/12/9/6Mbps 802.11n: up to 300Mbps 802.11ac: up to 867Mbps
Operating Frequency	5180~5240MHz, 5745~5825MHz
Number of Channel	5180~5240MHz: 802.11a, 802.11n (HT20), 802.11ac (VHT20): 4 802.11n (HT40), 802.11ac (VHT40): 2 802.11ac (VHT80): 1 5745~5825MHz: 802.11a, 802.11n (HT20), 802.11ac (VHT20): 5 802.11n (HT40), 802.11ac (VHT40): 2 802.11ac (VHT80): 1
Output Power	5180~5240MHz: CDD Mode: 195.535mW Beamforming Mode: 97.774mW 5745~5825MHz: CDD Mode: 321.706mW Beamforming Mode: 160.864mW
Antenna Type	Refer to Note
Antenna Connector	Refer to Note
Accessory Device	Adapter
Cable Supplied	NA

Note:

1. The EUT incorporates a MIMO function. Physically, the EUT provides 2 completed transmitters and 2 receivers.

Modulation Mode	CDD Mode	Beamforming Mode	TX function
802.11a	Support	Not Support	2TX
802.11n (HT20)	Support	Support	2TX
802.11n (HT40)	Support	Support	2TX
802.11ac (VHT20)	Support	Support	2TX
802.11ac (VHT40)	Support	Support	2TX
802.11ac (VHT80)	Support	Support	2TX

* The modulation and bandwidth are similar for 802.11n mode for 20MHz/40MHz and 802.11ac mode for 20MHz/40MHz, therefore investigated worst case to representative mode in test report. (Final test mode refer section 3.2.1)

* For 802.11n and 802.11ac, CDD mode and Beamforming mode are presented in power output test item. For other test items, CDD mode is the worst case for final tests after pretesting.

2. The EUT uses following adapter and PoE. (Support unit)

Adapter (Support unit)	
Brand	ENG Electric co., LTD.
Model	6A-501DB48
Input Power	100-240Vac~50-60Hz, 1.2A
Output Power	48Vdc / 1.05A
Power Line	1.5m AC cable with one core 1.75m DC cable without core

POE (Support unit)	
Brand	EnGenius
Model	EPA5006GAT
Input Power	100-240Vac~0.8A, 50-60Hz
Output Power	54Vdc / 0.6A PIN 4,5:54V PIN 7,8:RETURN

3. The following antennas were provided to the EUT.

Ant. No.	1	2	3	4
Frequency (MHz)	2400-2500		5150-5850	
Peak Gain (dBi)	3.38	4.26	5.30	5.62
Ant. Type	PIFA			
Connector	IPEX			

4. Spurious emission of the simultaneous operation has been evaluated and no non-compliance was found.

3.2 Description of Test Modes

5180~5240MHz:

4 channels are provided for 802.11a, 802.11n (HT20), 802.11ac (VHT20):

Channel	Frequency	Channel	Frequency
36	5180MHz	44	5220MHz
40	5200MHz	48	5240MHz

2 channels are provided for 802.11n (HT40), 802.11ac (VHT40):

Channel	Frequency	Channel	Frequency
38	5190MHz	46	5230MHz

1 channel is provided for 802.11ac (VHT80):

Channel	Frequency
42	5210MHz

5745~5825MHz:

5 channels are provided for 802.11a, 802.11n (HT20), 802.11ac (VHT20):

Channel	Frequency	Channel	Frequency
149	5745MHz	161	5805MHz
153	5765MHz	165	5825MHz
157	5785MHz		

2 channels are provided for 802.11n (HT40), 802.11ac (VHT40):

Channel	Frequency	Channel	Frequency
151	5755MHz	159	5795MHz

1 channel is provided for 802.11ac (VHT80):

Channel	Frequency
155	5775MHz

3.2.1 Test Mode Applicability and Tested Channel Detail

EUT Configure Mode	Applicable to				Description
	RE \geq 1G	RE<1G	PLC	APCM	
A	√	√	√	√	Power from adapter
B	-	√	√	-	Power from POE

Where RE \geq 1G: Radiated Emission above 1GHz & Bandedge Measurement
 RE<1G: Radiated Emission below 1GHz
 PLC: Power Line Conducted Emission
 APCM: Antenna Port Conducted Measurement

Note:

1. The EUT had been pre-tested on the positioned of each 3 axis. The worst case was found when positioned on Y-plane.
2. Radiated emission test (below 1GHz) and power line conducted emission test items chosen the worst maximum power

Radiated Emission Test (Above 1GHz):

- Pre-Scan has been conducted to determine the worst-case mode from all possible combinations between available modulations, data rates and antenna ports (if EUT with antenna diversity architecture).
- Following channel(s) was (were) selected for the final test as listed below.

EUT Configure Mode	Mode	Frequency Band (MHz)	Available Channel	Tested Channel	Modulation Technology	Data Rate (Mbps)	Remark
A	802.11a	5180-5240	36 to 48	36, 40, 48	OFDM	6.0	-
	802.11n (HT20)		36 to 48	36, 40, 48	OFDM	6.5	
	802.11n (HT40)		38 to 46	38, 46	OFDM	13.5	
	802.11ac (VHT80)		42	42	OFDM	29.3	
A	802.11a	5745-5825	149 to 165	149, 157, 165	OFDM	6.0	-
	802.11n (HT20)		149 to 165	149, 157, 165	OFDM	6.5	
	802.11n (HT40)		151 to 159	151, 159	OFDM	13.5	
	802.11ac (VHT80)		155	155	OFDM	29.3	

Radiated Emission Test (Below 1GHz):

- Pre-Scan has been conducted to determine the worst-case mode from all possible combinations between available modulations, data rates and antenna ports (if EUT with antenna diversity architecture).
- Following channel(s) was (were) selected for the final test as listed below.

EUT Configure Mode	Mode	Frequency Band (MHz)	Available Channel	Tested Channel	Modulation Technology	Data Rate (Mbps)	Remark
A, B	802.11n (HT20)	5745-5825	149 to 165	157	OFDM	6.5	-

Power Line Conducted Emission Test:

- Pre-Scan has been conducted to determine the worst-case mode from all possible combinations between available modulations, data rates and antenna ports (if EUT with antenna diversity architecture).
- Following channel(s) was (were) selected for the final test as listed below.

EUT Configure Mode	Mode	Frequency Band (MHz)	Available Channel	Tested Channel	Modulation Technology	Data Rate (Mbps)	Remark
A, B	802.11n (HT20)	5745-5825	149 to 165	157	OFDM	6.5	-

Antenna Port Conducted Measurement:

- This item includes all test value of each mode, but only includes spectrum plot of worst value of each mode.
- Pre-Scan has been conducted to determine the worst-case mode from all possible combinations between available modulations, data rates and antenna ports (if EUT with antenna diversity architecture).
- Following channel(s) was (were) selected for the final test as listed below.

EUT Configure Mode	Mode	Frequency Band (MHz)	Available Channel	Tested Channel	Modulation Technology	Data Rate (Mbps)	Remark
A	802.11a	5180-5240	36 to 48	36, 40, 48	OFDM	6.0	-
	802.11n (HT20)		36 to 48	36, 40, 48	OFDM	6.5	
	802.11n (HT40)		38 to 46	38, 46	OFDM	13.5	
	802.11ac (VHT80)		42	42	OFDM	29.3	
A	802.11a	5745-5825	149 to 165	149, 157, 165	OFDM	6.0	-
	802.11n (HT20)		149 to 165	149, 157, 165	OFDM	6.5	
	802.11n (HT40)		151 to 159	151, 159	OFDM	13.5	
	802.11ac (VHT80)		155	155	OFDM	29.3	

Test Condition:

Applicable to	Environmental Conditions	Input Power	Tested by
RE \geq 1G	23 deg. C, 67% RH	120Vac, 60Hz	Adair Peng
RE $<$ 1G	24 deg. C, 70% RH	120Vac, 60Hz 54Vdc	Willy Cheng
PLC	23 deg. C, 66% RH	120Vac, 60Hz 54Vdc	Willy Cheng
APCM	25 deg. C, 60% RH	120Vac, 60Hz	Ivan Tseng

3.3 Duty Cycle of Test Signal

Duty cycle of test signal is $\geq 98\%$, duty factor is not required.

Duty cycle of test signal is $< 98\%$, duty factor shall be considered.

802.11a: Duty cycle = $2.053/2.155 = 0.953$, Duty factor = $10 * \log(1/0.953) = 0.21$

802.11n (HT20): Duty cycle = $4.975/5.10 = 0.975$, Duty factor = $10 * \log(1/0.975) = 0.11$

802.11n (HT40): Duty cycle = $2.420/2.532 = 0.956$, Duty factor = $10 * \log(1/0.956) = 0.20$

802.11ac (VHT80): Duty cycle = $1.144/1.226 = 0.933$, Duty factor = $10 * \log(1/0.933) = 0.30$

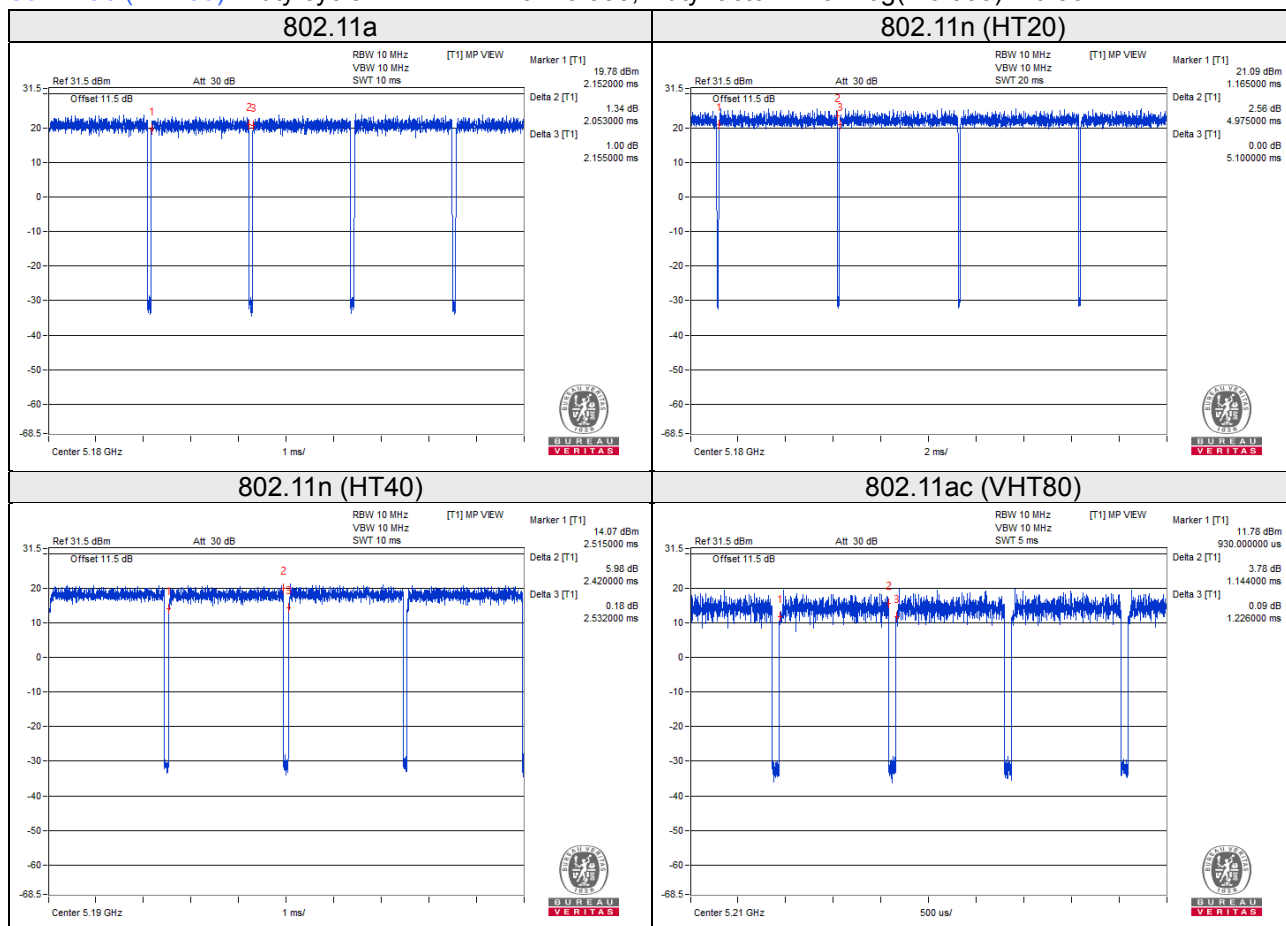

3.4 Description of Support Units

The EUT has been tested as an independent unit together with other necessary accessories or support units. The following support units or accessories were used to form a representative test configuration during the tests.

ID	Product	Brand	Model No.	Serial No.	FCC ID	Remarks
A.	Notebook	DELL	E5410	1HC2XM1	FCC DoC Approved	-
B.	Load	NA	NA	NA	NA	-
C.	Adapter	ENG Electric co., LTD.	6A-501DB48	NA	NA	Provided by client
D.	PoE	EnGenius	EPA5006GAT	NA	NA	Provided by client

Note:

1. All power cords of the above support units are non-shielded (1.8m).
2. Item A acted as a communication partner to transfer data.

ID	Descriptions	Qty.	Length (m)	Shielding (Yes/No)	Cores (Qty.)	Remarks
1.	RJ45, Cat5e	1	5.0	N	0	-
2.	RJ45, Cat5e	2	1.5	N	0	-
3.	RJ45, Cat5e	1	1.5	N	0	-

3.4.1 Configuration of System under Test

Test Mode A

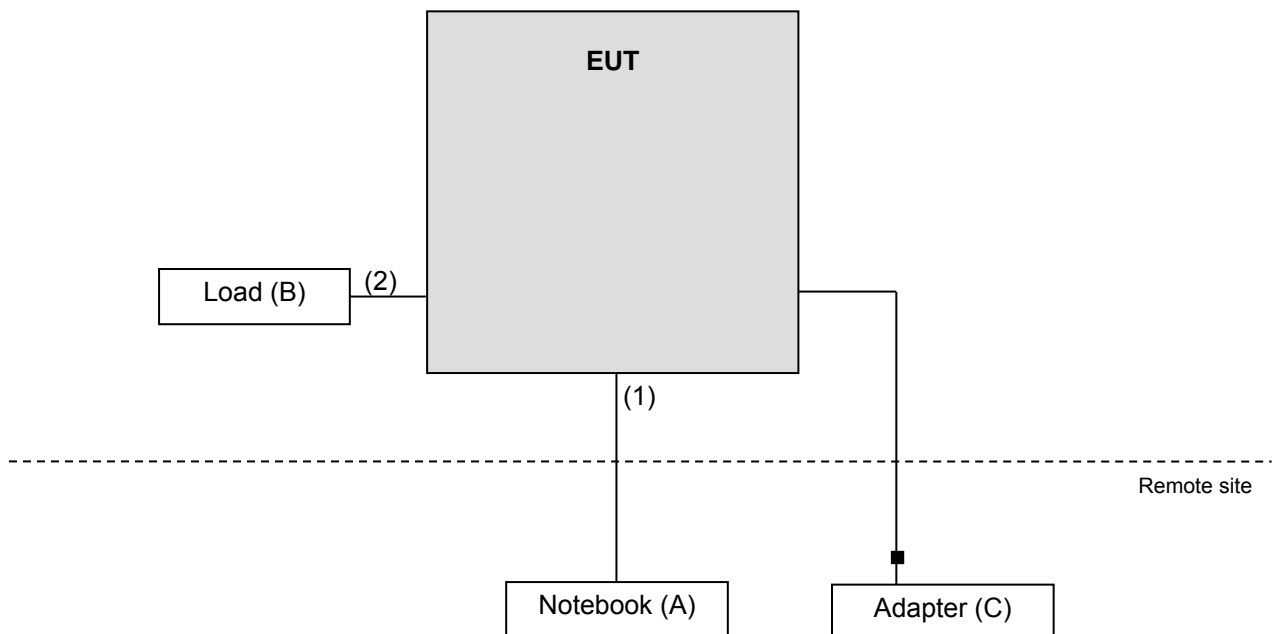

Test Mode B

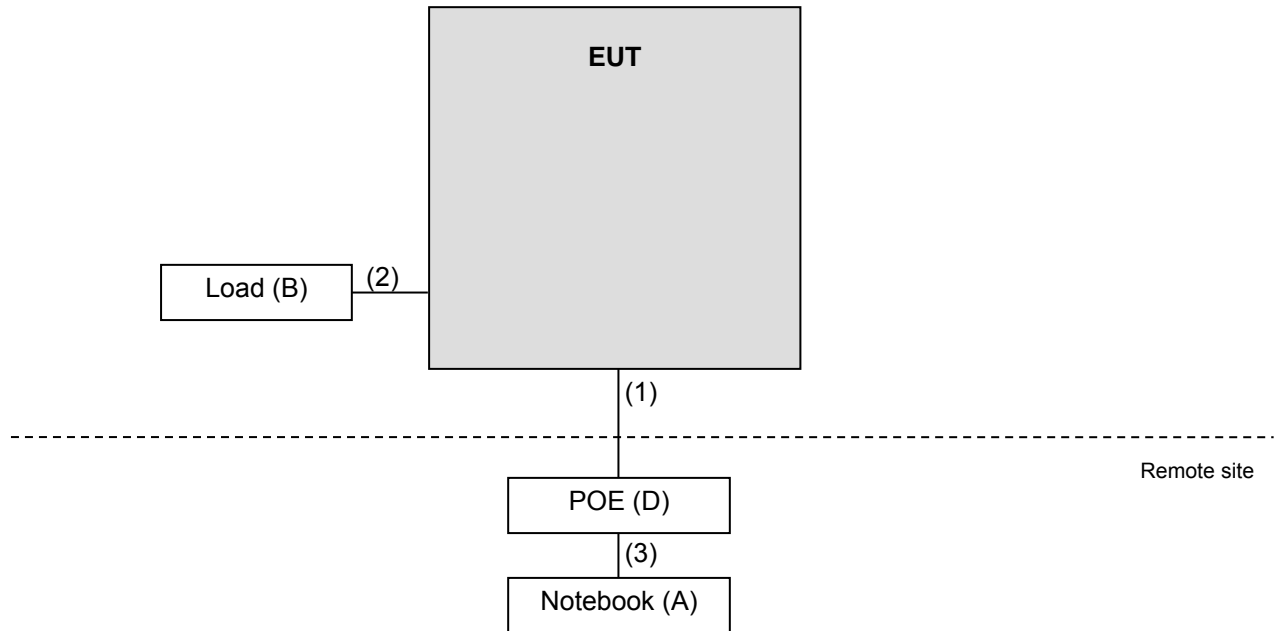

3.5 General Description of Applied Standards

The EUT is a RF Product. According to the specifications of the manufacturer, it must comply with the requirements of the following standards:

FCC Part 15, Subpart E (15.407)

KDB 789033 D02 General UNII Test Procedure New Rules v02r01

KDB 662911 D01 Multiple Transmitter Output v02r01

ANSI C63.10:2013

All test items have been performed and recorded as per the above standards.

4 Test Types and Results

4.1 Radiated Emission and Bandedge Measurement

4.1.1 Limits of Radiated Emission and Bandedge Measurement

Radiated emissions which fall in the restricted bands must comply with the radiated emission limits specified as below table.

Frequencies (MHz)	Field Strength (microvolts/meter)	Measurement Distance (meters)
0.009 ~ 0.490	2400/F(kHz)	300
0.490 ~ 1.705	24000/F(kHz)	30
1.705 ~ 30.0	30	30
30 ~ 88	100	3
88 ~ 216	150	3
216 ~ 960	200	3
Above 960	500	3

NOTE:

- The lower limit shall apply at the transition frequencies.
- Emission level (dBuV/m) = 20 log Emission level (uV/m).
- For frequencies above 1000MHz, the field strength limits are based on average detector, however, the peak field strength of any emission shall not exceed the maximum permitted average limits, specified above by more than 20dB under any condition of modulation.

Limits of unwanted emission out of the restricted bands

Applicable To		Limit	
789033 D02 General UNII Test Procedure New Rules v02r01		Field Strength at 3m	
		PK: 74 (dBµV/m)	AV: 54 (dBµV/m)
Frequency Band	Applicable To	EIRP Limit	Equivalent Field Strength at 3m
5150~5250 MHz	15.407(b)(1)	PK: -27 (dBm/MHz)	PK: 68.2(dBµV/m)
5250~5350 MHz	15.407(b)(2)		
5470~5725 MHz	15.407(b)(3)		
5725~5850 MHz	<input checked="" type="checkbox"/> 15.407(b)(4)(i)	PK: -27 (dBm/MHz) ^{*1} PK: 10 (dBm/MHz) ^{*2} PK: 15.6 (dBm/MHz) ^{*3} PK: 27 (dBm/MHz) ^{*4}	PK: 68.2 (dBµV/m) ^{*1} PK: 105.2 (dBµV/m) ^{*2} PK: 110.8 (dBµV/m) ^{*3} PK: 122.2 (dBµV/m) ^{*4}
	<input type="checkbox"/> 15.407(b)(4)(ii)	Emission limits in section 15.247(d)	
^{*1} beyond 75 MHz or more above of the band edge.		^{*2} below the band edge increasing linearly to 10 dBm/MHz at 25 MHz above.	
^{*3} below the band edge increasing linearly to a level of 15.6 dBm/MHz at 5 MHz above.		^{*4} from 5 MHz above or below the band edge increasing linearly to a level of 27 dBm/MHz at the band edge.	

Note: The following formula is used to convert the equipment isotropic radiated power (eirp) to field strength:

$$E = \frac{1000000 \sqrt{30 P}}{3} \mu\text{V/m, where P is the eirp (Watts).}$$

4.1.2 Test Instruments

Description & Manufacturer	Model No.	Serial No.	Cal. Date	Cal. Due
Test Receiver ROHDE & SCHWARZ	ESIB7	100187	May 30, 2019	May 29, 2020
Spectrum Analyzer ROHDE & SCHWARZ	FSP40	100269	Jun. 10, 2019	Jun. 09, 2020
BILOG Antenna SCHWARZBECK	VULB9168	9168-171	Nov. 22, 2018	Nov. 21, 2019
HORN Antenna SCHWARZBECK	9120D	209	Nov. 25, 2018	Nov. 24, 2019
HORN Antenna SCHWARZBECK	BBHA 9170	BBHA9170241	Nov. 25, 2018	Nov. 24, 2019
Preamplifier Agilent (Below 1GHz)	8447D	2944A10738	Aug. 21, 2018	Aug. 20, 2019
Preamplifier Agilent (Above 1GHz)	8449B	3008A02465	Mar. 27, 2019	Mar. 26, 2020
RF signal cable HUBER+SUHNER	SUCOFLEX 104	Cable-CH3-03 (223653/4)	Aug. 21, 2018	Aug. 20, 2019
RF signal cable HUBER+SUHNER& EMCI	SUCOFLEX 104&EMC104-SM-SM-8 000	Cable-CH3-03 (309224+170907)	Aug. 21, 2018	Aug. 20, 2019
RF signal cable WOKEN	8D-FB	Cable-CH3-01	Aug. 21, 2018	Aug. 20, 2019
Software BV ADT	ADT_Radiated_ V7.6.15.9.5	NA	NA	NA
Antenna Tower inn-co GmbH	MA 4000	013303	NA	NA
Antenna Tower Controller BV ADT	AT100	AT93021702	NA	NA
Turn Table BV ADT	TT100	TT93021702	NA	NA
Turn Table Controller BV ADT	SC100	SC93021702	NA	NA
Boresight Antenna Fixture	FBA-01	FBA-SIP01	NA	NA
Pre-amplifier (18GHz-40GHz) EMC	EMC184045B	980175	Nov. 14, 2018	Nov. 13, 2019
USB Wideband Power Sensor KEYSIGHT	U2021XA	MY55050005/MY5519 0004/MY55190007/MY 55210005	Jul. 15, 2019	Jul. 14, 2020

Note: 1. The calibration interval of the above test instruments is 12 months and the calibrations are traceable to NML/ROC and NIST/USA.
2. The test was performed in HwaYa Chamber 3.

4.1.3 Test Procedures

For Radiated emission below 30MHz

- a. The EUT was placed on the top of a rotating table 0.8 meters above the ground at a 3 meter chamber room. The table was rotated 360 degrees to determine the position of the highest radiation.
- b. The EUT was set 3 meters away from the interference-receiving antenna, which was mounted on the top of a variable-height antenna tower.
- c. Parallel, perpendicular, and ground-parallel orientations of the antenna are set to make the measurement.
- d. For each suspected emission, the EUT was arranged to its worst case and the rotatable table was turned from 0 degrees to 360 degrees to find the maximum reading.
- e. The test-receiver system was set to Quasi-Peak Detect Function and Specified Bandwidth with Maximum Hold Mode.

Note:

1. The resolution bandwidth and video bandwidth of test receiver/spectrum analyzer is 9kHz at frequency below 30MHz.

For Radiated emission above 30MHz

- a. The EUT was placed on the top of a rotating table 0.8 meters (for 30MHz ~ 1GHz) / 1.5 meters (for above 1GHz) above the ground at 3 meter chamber room for test. The table was rotated 360 degrees to determine the position of the highest radiation.
- b. The EUT was set 3 meters away from the interference-receiving antenna, which was mounted on the top of a variable-height antenna tower.
- c. The height of antenna is varied from one meter to four meters above the ground to determine the maximum value of the field strength. Both horizontal and vertical polarizations of the antenna are set to make the measurement.
- d. For each suspected emission, the EUT was arranged to its worst case and then the antenna was tuned to heights from 1 meter to 4 meters and the rotatable table was turned from 0 degrees to 360 degrees to find the maximum reading.
- e. The test-receiver system was set to quasi-peak detect function and specified bandwidth with maximum hold mode when the test frequency is below 1 GHz.
- f. The test-receiver system was set to peak and average detect function and specified bandwidth with maximum hold mode when the test frequency is above 1 GHz. If the peak reading value also meets average limit, measurement with the average detector is unnecessary.

Note:

1. The resolution bandwidth and video bandwidth of test receiver/spectrum analyzer is 120kHz for Quasi-peak detection (QP) at frequency below 1GHz.
2. The resolution bandwidth of test receiver/spectrum analyzer is 1 MHz and the video bandwidth is 3 MHz for Peak detection (PK) at frequency above 1GHz.
3. The resolution bandwidth of test receiver/spectrum analyzer is 1MHz and the video bandwidth is $\geq 1/T$ (Duty cycle < 98%) or 10Hz (Duty cycle $\geq 98\%$) for Average detection (AV) at frequency above 1GHz. (802.11a: RBW = 1MHz, VBW =1kHz; 802.11n (HT20): RBW = 1MHz, VBW =300Hz; 802.11n (HT40): RBW = 1MHz, VBW =1kHz; 802.11ac (VHT80): RBW = 1MHz, VBW =1kHz)
4. All modes of operation were investigated and the worst-case emissions are reported.

4.1.4 Deviation from Test Standard

No deviation.

4.1.5 Test Setup

For Radiated emission below 30MHz

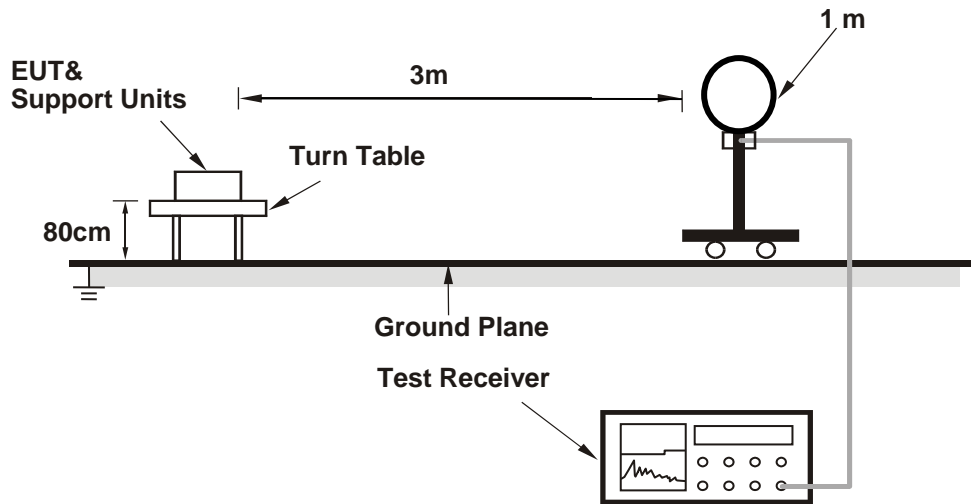

For Radiated emission 30MHz to 1GHz

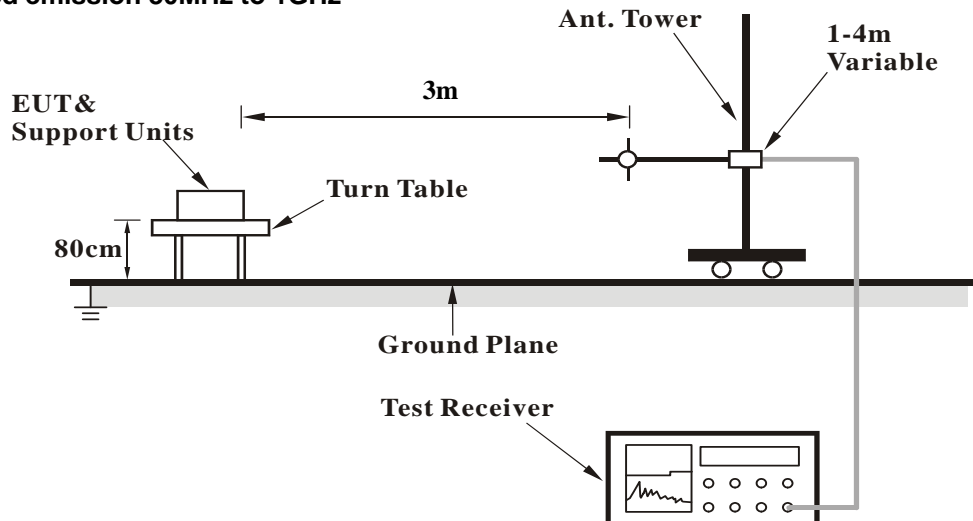

For Radiated emission above 1GHz

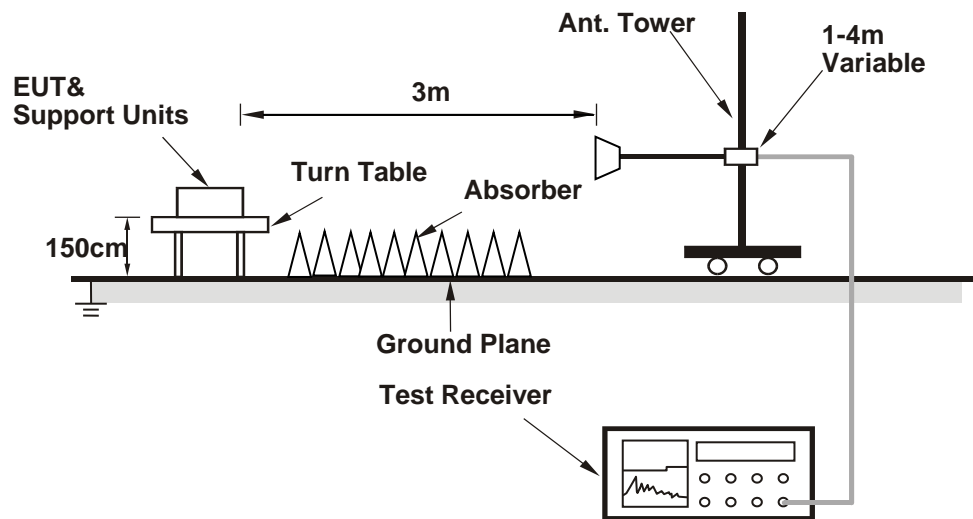

For the actual test configuration, please refer to the attached file (Test Setup Photo).

4.1.6 EUT Operating Conditions

- Placed the EUT on the testing table.
- Prepared a notebook to act as a communication partner and placed it outside of testing area.
- The communication partner connected with EUT via a RJ45 cable and ran a test program (provided by manufacturer) to enable EUT under transmission condition continuously at specific channel frequency.
- The communication partner sent data to EUT by command "PING".

4.1.7 Test Results

Above 1GHz data:

802.11a

CHANNEL	TX Channel 36	DETECTOR FUNCTION	Peak (PK)
FREQUENCY RANGE	1GHz ~ 40GHz		Average (AV)

ANTENNA POLARITY & TEST DISTANCE: HORIZONTAL AT 3 M								
NO.	FREQ. (MHz)	EMISSION LEVEL (dBuV/m)	LIMIT (dBuV/m)	MARGIN (dB)	ANTENNA HEIGHT (m)	TABLE ANGLE (Degree)	RAW VALUE (dBuV)	CORRECTION FACTOR (dB/m)
1	5150.00	65.3 PK	74.0	-8.7	2.23 H	290	60.9	4.4
2	5150.00	47.9 AV	54.0	-6.1	2.23 H	290	43.5	4.4
3	*5180.00	114.8 PK			2.23 H	298	75.3	39.5
4	*5180.00	104.0 AV			2.23 H	298	64.5	39.5
5	#10360.00	57.3 PK	68.2	-10.9	1.99 H	270	41.3	16.0
6	15540.00	70.1 PK	74.0	-3.9	1.88 H	199	53.3	16.8
7	15540.00	53.1 AV	54.0	-0.9	1.88 H	199	36.3	16.8
ANTENNA POLARITY & TEST DISTANCE: VERTICAL AT 3 M								
NO.	FREQ. (MHz)	EMISSION LEVEL (dBuV/m)	LIMIT (dBuV/m)	MARGIN (dB)	ANTENNA HEIGHT (m)	TABLE ANGLE (Degree)	RAW VALUE (dBuV)	CORRECTION FACTOR (dB/m)
1	5150.00	63.0 PK	74.0	-11.0	3.79 V	330	58.6	4.4
2	5150.00	46.1 AV	54.0	-7.9	3.79 V	330	41.7	4.4
3	*5180.00	113.7 PK			3.74 V	350	74.2	39.5
4	*5180.00	102.7 AV			3.74 V	350	63.2	39.5
5	#10360.00	57.0 PK	68.2	-11.2	1.62 V	333	41.0	16.0
6	15540.00	64.5 PK	74.0	-9.5	2.92 V	326	47.7	16.8
7	15540.00	50.1 AV	54.0	-3.9	2.92 V	326	33.3	16.8

Remarks:

1. Emission Level(dBuV/m) = Raw Value(dBuV) + Correction Factor(dB/m)
2. Correction Factor(dB/m) = Antenna Factor(dB/m) + Cable Factor(dB) – Pre-Amplifier Factor(dB)
3. The other emission levels were very low against the limit.
4. Margin value = Emission Level – Limit value
5. " * ": Fundamental frequency.
6. " # ": The radiated frequency is out of the restricted band.

CHANNEL	TX Channel 40	DETECTOR FUNCTION	Peak (PK)
FREQUENCY RANGE	1GHz ~ 40GHz		Average (AV)

ANTENNA POLARITY & TEST DISTANCE: HORIZONTAL AT 3 M								
NO.	FREQ. (MHz)	EMISSION LEVEL (dBuV/m)	LIMIT (dBuV/m)	MARGIN (dB)	ANTENNA HEIGHT (m)	TABLE ANGLE (Degree)	RAW VALUE (dBuV)	CORRECTION FACTOR (dB/m)
1	*5200.00	113.9 PK			2.21 H	293	74.4	39.5
2	*5200.00	103.7 AV			2.21 H	293	64.2	39.5
3	#10400.00	57.7 PK	68.2	-10.5	2.19 H	265	41.5	16.2
4	15600.00	71.4 PK	74.0	-2.6	2.40 H	246	54.2	17.2
5	15600.00	53.8 AV	54.0	-0.2	2.40 H	246	36.6	17.2

ANTENNA POLARITY & TEST DISTANCE: VERTICAL AT 3 M								
NO.	FREQ. (MHz)	EMISSION LEVEL (dBuV/m)	LIMIT (dBuV/m)	MARGIN (dB)	ANTENNA HEIGHT (m)	TABLE ANGLE (Degree)	RAW VALUE (dBuV)	CORRECTION FACTOR (dB/m)
1	*5200.00	112.6 PK			3.77 V	315	73.1	39.5
2	*5200.00	102.7 AV			3.77 V	315	63.2	39.5
3	#10400.00	57.9 PK	68.2	-10.3	1.77 V	350	41.7	16.2
4	15600.00	65.2 PK	74.0	-8.8	2.97 V	328	48.0	17.2
5	15600.00	50.1 AV	54.0	-3.9	2.97 V	328	32.9	17.2

Remarks:

1. Emission Level(dBuV/m) = Raw Value(dBuV) + Correction Factor(dB/m)
2. Correction Factor(dB/m) = Antenna Factor(dB/m) + Cable Factor(dB) – Pre-Amplifier Factor(dB)
3. The other emission levels were very low against the limit.
4. Margin value = Emission Level – Limit value
5. " * ": Fundamental frequency.
6. " # ": The radiated frequency is out of the restricted band.

CHANNEL	TX Channel 48	DETECTOR FUNCTION	Peak (PK)
FREQUENCY RANGE	1GHz ~ 40GHz		Average (AV)

ANTENNA POLARITY & TEST DISTANCE: HORIZONTAL AT 3 M								
NO.	FREQ. (MHz)	EMISSION LEVEL (dBuV/m)	LIMIT (dBuV/m)	MARGIN (dB)	ANTENNA HEIGHT (m)	TABLE ANGLE (Degree)	RAW VALUE (dBuV)	CORRECTION FACTOR (dB/m)
1	*5240.00	115.2 PK			2.26 H	285	75.9	39.3
2	*5240.00	104.3 AV			2.26 H	285	65.0	39.3
3	5350.00	55.8 PK	74.0	-18.2	2.03 H	290	51.5	4.3
4	5350.00	43.2 AV	54.0	-10.8	2.03 H	290	38.9	4.3
5	#10400.00	57.2 PK	68.2	-11.0	2.01 H	266	41.0	16.2
6	15720.00	70.6 PK	74.0	-3.4	2.29 H	221	54.4	16.2
7	15720.00	53.1 AV	54.0	-0.9	2.29 H	221	36.9	16.2

ANTENNA POLARITY & TEST DISTANCE: VERTICAL AT 3 M								
NO.	FREQ. (MHz)	EMISSION LEVEL (dBuV/m)	LIMIT (dBuV/m)	MARGIN (dB)	ANTENNA HEIGHT (m)	TABLE ANGLE (Degree)	RAW VALUE (dBuV)	CORRECTION FACTOR (dB/m)
1	*5240.00	113.6 PK			3.39 V	321	74.3	39.3
2	*5240.00	103.2 AV			3.39 V	321	63.9	39.3
3	5350.00	56.6 PK	74.0	-17.4	3.20 V	314	52.3	4.3
4	5350.00	43.1 AV	54.0	-10.9	3.20 V	314	38.8	4.3
5	#10480.00	58.3 PK	68.2	-9.9	1.77 V	339	41.3	17.0
6	15720.00	65.2 PK	74.0	-8.8	2.91 V	328	49.0	16.2
7	15720.00	49.4 AV	54.0	-4.6	2.91 V	328	33.2	16.2

Remarks:

1. Emission Level(dBuV/m) = Raw Value(dBuV) + Correction Factor(dB/m)
2. Correction Factor(dB/m) = Antenna Factor(dB/m) + Cable Factor(dB) – Pre-Amplifier Factor(dB)
3. The other emission levels were very low against the limit.
4. Margin value = Emission Level – Limit value
5. " * ": Fundamental frequency.
6. " # ": The radiated frequency is out of the restricted band.

CHANNEL	TX Channel 149	DETECTOR FUNCTION	Peak (PK) Average (AV)
FREQUENCY RANGE	1GHz ~ 40GHz		

ANTENNA POLARITY & TEST DISTANCE: HORIZONTAL AT 3 M

NO.	FREQ. (MHz)	EMISSION LEVEL (dBuV/m)	LIMIT (dBuV/m)	MARGIN (dB)	ANTENNA HEIGHT (m)	TABLE ANGLE (Degree)	RAW VALUE (dBuV)	CORRECTION FACTOR (dB/m)
1	#5600.80	57.5 PK	68.2	-10.7	2.48 H	309	52.9	4.6
2	*5745.00	115.1 PK			2.48 H	309	75.0	40.1
3	*5745.00	105.0 AV			2.48 H	309	64.9	40.1
4	#5987.20	58.3 PK	68.2	-9.9	2.48 H	309	52.9	5.4
5	11490.00	61.4 PK	74.0	-12.6	1.91 H	77	43.4	18.0
6	11490.00	48.7 AV	54.0	-5.3	1.91 H	77	30.7	18.0
7	#17235.00	67.8 PK	68.2	-0.4	1.49 H	190	46.5	21.3

ANTENNA POLARITY & TEST DISTANCE: VERTICAL AT 3 M

NO.	FREQ. (MHz)	EMISSION LEVEL (dBuV/m)	LIMIT (dBuV/m)	MARGIN (dB)	ANTENNA HEIGHT (m)	TABLE ANGLE (Degree)	RAW VALUE (dBuV)	CORRECTION FACTOR (dB/m)
1	#5616.00	56.6 PK	68.2	-11.6	3.99 V	340	52.0	4.6
2	*5745.00	114.3 PK			3.99 V	340	74.2	40.1
3	*5745.00	104.1 AV			3.99 V	340	64.0	40.1
4	#5952.80	57.8 PK	68.2	-10.4	3.99 V	340	52.5	5.3
5	11490.00	60.4 PK	74.0	-13.6	1.65 V	159	42.4	18.0
6	11490.00	46.2 AV	54.0	-7.8	1.65 V	159	28.2	18.0
7	#17235.00	67.3 PK	68.2	-0.9	1.88 V	209	46.0	21.3

Remarks:

1. Emission Level(dBuV/m) = Raw Value(dBuV) + Correction Factor(dB/m)
2. Correction Factor(dB/m) = Antenna Factor(dB/m) + Cable Factor(dB) – Pre-Amplifier Factor(dB)
3. The other emission levels were very low against the limit.
4. Margin value = Emission Level – Limit value
5. " * ": Fundamental frequency.
6. " # ": The radiated frequency is out of the restricted band.

CHANNEL	TX Channel 157	DETECTOR FUNCTION	Peak (PK)
FREQUENCY RANGE	1GHz ~ 40GHz		Average (AV)

ANTENNA POLARITY & TEST DISTANCE: HORIZONTAL AT 3 M								
NO.	FREQ. (MHz)	EMISSION LEVEL (dBuV/m)	LIMIT (dBuV/m)	MARGIN (dB)	ANTENNA HEIGHT (m)	TABLE ANGLE (Degree)	RAW VALUE (dBuV)	CORRECTION FACTOR (dB/m)
1	#5615.20	57.1 PK	68.2	-11.1	2.59 H	310	52.5	4.6
2	*5785.00	115.5 PK			2.59 H	310	75.2	40.3
3	*5785.00	105.3 AV			2.59 H	310	65.0	40.3
4	#5981.60	57.3 PK	68.2	-10.9	2.59 H	310	51.9	5.4
5	11570.00	58.2 PK	74.0	-15.8	3.11 H	81	40.5	17.7
6	11570.00	45.1 AV	54.0	-8.9	3.11 H	81	27.4	17.7
7	#17355.00	67.7 PK	68.2	-0.5	2.19 H	195	45.5	22.2

ANTENNA POLARITY & TEST DISTANCE: VERTICAL AT 3 M								
NO.	FREQ. (MHz)	EMISSION LEVEL (dBuV/m)	LIMIT (dBuV/m)	MARGIN (dB)	ANTENNA HEIGHT (m)	TABLE ANGLE (Degree)	RAW VALUE (dBuV)	CORRECTION FACTOR (dB/m)
1	#5600.00	56.7 PK	68.2	-11.5	3.75 V	348	52.1	4.6
2	*5785.00	115.6 PK			3.75 V	348	75.3	40.3
3	*5785.00	104.8 AV			3.75 V	348	64.5	40.3
4	#5995.20	56.7 PK	68.2	-11.5	3.75 V	348	51.3	5.4
5	11570.00	58.6 PK	74.0	-15.4	1.70 V	163	40.9	17.7
6	11570.00	45.0 AV	54.0	-9.0	1.70 V	163	27.3	17.7
7	#17355.00	67.3 PK	68.2	-0.9	1.97 V	213	45.1	22.2

Remarks:

1. Emission Level(dBuV/m) = Raw Value(dBuV) + Correction Factor(dB/m)
2. Correction Factor(dB/m) = Antenna Factor(dB/m) + Cable Factor(dB) – Pre-Amplifier Factor(dB)
3. The other emission levels were very low against the limit.
4. Margin value = Emission Level – Limit value
5. " * ": Fundamental frequency.
6. " # ": The radiated frequency is out of the restricted band.

CHANNEL	TX Channel 165	DETECTOR FUNCTION	Peak (PK)
FREQUENCY RANGE	1GHz ~ 40GHz		Average (AV)

ANTENNA POLARITY & TEST DISTANCE: HORIZONTAL AT 3 M								
NO.	FREQ. (MHz)	EMISSION LEVEL (dBuV/m)	LIMIT (dBuV/m)	MARGIN (dB)	ANTENNA HEIGHT (m)	TABLE ANGLE (Degree)	RAW VALUE (dBuV)	CORRECTION FACTOR (dB/m)
1	#5602.40	56.4 PK	68.2	-11.8	2.37 H	303	51.8	4.6
2	*5825.00	113.9 PK			2.37 H	303	73.5	40.4
3	*5825.00	103.6 AV			2.37 H	303	63.2	40.4
4	#5974.40	57.1 PK	68.2	-11.1	2.37 H	303	51.7	5.4
5	11650.00	59.3 PK	74.0	-14.7	1.71 H	20	41.8	17.5
6	11650.00	46.5 AV	54.0	-7.5	1.71 H	20	29.0	17.5
7	#17475.00	67.9 PK	68.2	-0.3	2.37 H	219	44.2	23.7

ANTENNA POLARITY & TEST DISTANCE: VERTICAL AT 3 M								
NO.	FREQ. (MHz)	EMISSION LEVEL (dBuV/m)	LIMIT (dBuV/m)	MARGIN (dB)	ANTENNA HEIGHT (m)	TABLE ANGLE (Degree)	RAW VALUE (dBuV)	CORRECTION FACTOR (dB/m)
1	#5620.80	57.0 PK	68.2	-11.2	3.69 V	344	52.4	4.6
2	*5825.00	114.2 PK			3.69 V	344	73.8	40.4
3	*5825.00	103.8 AV			3.69 V	344	63.4	40.4
4	#5975.20	57.5 PK	68.2	-10.7	3.69 V	344	52.1	5.4
5	11650.00	59.2 PK	74.0	-14.8	1.69 V	165	41.7	17.5
6	11650.00	46.2 AV	54.0	-7.8	1.69 V	165	28.7	17.5
7	#17475.00	67.5 PK	68.2	-0.7	1.80 V	199	43.8	23.7

Remarks:

1. Emission Level(dBuV/m) = Raw Value(dBuV) + Correction Factor(dB/m)
2. Correction Factor(dB/m) = Antenna Factor(dB/m) + Cable Factor(dB) – Pre-Amplifier Factor(dB)
3. The other emission levels were very low against the limit.
4. Margin value = Emission Level – Limit value
5. " * ": Fundamental frequency.
6. " # ": The radiated frequency is out of the restricted band.

802.11n (HT20)

CHANNEL	TX Channel 36	DETECTOR FUNCTION	Peak (PK) Average (AV)
FREQUENCY RANGE	1GHz ~ 40GHz		

ANTENNA POLARITY & TEST DISTANCE: HORIZONTAL AT 3 M

NO.	FREQ. (MHz)	EMISSION LEVEL (dBuV/m)	LIMIT (dBuV/m)	MARGIN (dB)	ANTENNA HEIGHT (m)	TABLE ANGLE (Degree)	RAW VALUE (dBuV)	CORRECTION FACTOR (dB/m)
1	5150.00	60.7 PK	74.0	-13.3	2.27 H	279	56.3	4.4
2	5150.00	46.5 AV	54.0	-7.5	2.27 H	279	42.1	4.4
3	*5180.00	115.4 PK			2.35 H	298	75.9	39.5
4	*5180.00	103.9 AV			2.35 H	298	64.4	39.5
5	#10360.00	57.2 PK	68.2	-11.0	2.05 H	277	41.2	16.0
6	15540.00	73.2 PK	74.0	-0.8	1.93 H	184	56.4	16.8
7	15540.00	53.6 AV	54.0	-0.4	1.93 H	187	36.8	16.8

ANTENNA POLARITY & TEST DISTANCE: VERTICAL AT 3 M

NO.	FREQ. (MHz)	EMISSION LEVEL (dBuV/m)	LIMIT (dBuV/m)	MARGIN (dB)	ANTENNA HEIGHT (m)	TABLE ANGLE (Degree)	RAW VALUE (dBuV)	CORRECTION FACTOR (dB/m)
1	5150.00	58.2 PK	74.0	-15.8	3.64 V	309	53.8	4.4
2	5150.00	45.0 AV	54.0	-9.0	3.64 V	309	40.6	4.4
3	*5180.00	113.2 PK			3.78 V	312	73.7	39.5
4	*5180.00	102.3 AV			3.78 V	312	62.8	39.5
5	#10360.00	57.5 PK	68.2	-10.7	1.81 V	350	41.5	16.0
6	15540.00	66.0 PK	74.0	-8.0	3.69 V	15	49.2	16.8
7	15540.00	51.3 AV	54.0	-2.7	3.69 V	15	34.5	16.8

Remarks:

1. Emission Level(dBuV/m) = Raw Value(dBuV) + Correction Factor(dB/m)
2. Correction Factor(dB/m) = Antenna Factor(dB/m) + Cable Factor(dB) – Pre-Amplifier Factor(dB)
3. The other emission levels were very low against the limit.
4. Margin value = Emission Level – Limit value
5. " * ": Fundamental frequency.
6. " # ": The radiated frequency is out of the restricted band.

CHANNEL	TX Channel 40	DETECTOR FUNCTION	Peak (PK)
FREQUENCY RANGE	1GHz ~ 40GHz		Average (AV)

ANTENNA POLARITY & TEST DISTANCE: HORIZONTAL AT 3 M								
NO.	FREQ. (MHz)	EMISSION LEVEL (dBuV/m)	LIMIT (dBuV/m)	MARGIN (dB)	ANTENNA HEIGHT (m)	TABLE ANGLE (Degree)	RAW VALUE (dBuV)	CORRECTION FACTOR (dB/m)
1	*5200.00	114.5 PK			2.30 H	287	75.0	39.5
2	*5200.00	103.8 AV			2.30 H	287	64.3	39.5
3	#10400.00	57.4 PK	68.2	-10.8	1.87 H	266	41.2	16.2
4	15600.00	72.9 PK	74.0	-1.1	2.46 H	247	55.7	17.2
5	15600.00	53.4 AV	54.0	-0.6	2.46 H	247	36.2	17.2
ANTENNA POLARITY & TEST DISTANCE: VERTICAL AT 3 M								
NO.	FREQ. (MHz)	EMISSION LEVEL (dBuV/m)	LIMIT (dBuV/m)	MARGIN (dB)	ANTENNA HEIGHT (m)	TABLE ANGLE (Degree)	RAW VALUE (dBuV)	CORRECTION FACTOR (dB/m)
1	*5200.00	113.1 PK			3.46 V	324	73.6	39.5
2	*5200.00	102.2 AV			3.46 V	324	62.7	39.5
3	#10400.00	57.2 PK	68.2	-11.0	1.77 V	331	41.0	16.2
4	15600.00	64.9 PK	74.0	-9.1	3.16 V	322	47.7	17.2
5	15600.00	50.4 AV	54.0	-3.6	3.16 V	322	33.2	17.2

Remarks:

1. Emission Level(dBuV/m) = Raw Value(dBuV) + Correction Factor(dB/m)
2. Correction Factor(dB/m) = Antenna Factor(dB/m) + Cable Factor(dB) – Pre-Amplifier Factor(dB)
3. The other emission levels were very low against the limit.
4. Margin value = Emission Level – Limit value
5. " * ": Fundamental frequency.
6. " # ": The radiated frequency is out of the restricted band.

CHANNEL	TX Channel 48	DETECTOR FUNCTION	Peak (PK)
FREQUENCY RANGE	1GHz ~ 40GHz		Average (AV)

ANTENNA POLARITY & TEST DISTANCE: HORIZONTAL AT 3 M								
NO.	FREQ. (MHz)	EMISSION LEVEL (dBuV/m)	LIMIT (dBuV/m)	MARGIN (dB)	ANTENNA HEIGHT (m)	TABLE ANGLE (Degree)	RAW VALUE (dBuV)	CORRECTION FACTOR (dB/m)
1	*5240.00	115.2 PK			2.26 H	285	75.9	39.3
2	*5240.00	104.6 AV			2.26 H	285	65.3	39.3
3	5350.00	56.3 PK	74.0	-17.7	2.11 H	291	52.0	4.3
4	5350.00	43.2 AV	54.0	-10.8	2.11 H	291	38.9	4.3
5	#10480.00	58.3 PK	68.2	-9.9	1.95 H	278	41.3	17.0
6	15720.00	72.7 PK	74.0	-1.3	2.20 H	251	56.5	16.2
7	15720.00	53.6 AV	54.0	-0.4	2.20 H	251	37.4	16.2

ANTENNA POLARITY & TEST DISTANCE: VERTICAL AT 3 M								
NO.	FREQ. (MHz)	EMISSION LEVEL (dBuV/m)	LIMIT (dBuV/m)	MARGIN (dB)	ANTENNA HEIGHT (m)	TABLE ANGLE (Degree)	RAW VALUE (dBuV)	CORRECTION FACTOR (dB/m)
1	*5240.00	113.8 PK			3.91 V	310	74.5	39.3
2	*5240.00	103.0 AV			3.91 V	310	63.7	39.3
3	5350.00	55.9 PK	74.0	-18.1	3.69 V	322	51.6	4.3
4	5350.00	42.8 AV	54.0	-11.2	3.69 V	322	38.5	4.3
5	#10480.00	58.6 PK	68.2	-9.6	1.70 V	343	41.6	17.0
6	15720.00	68.6 PK	74.0	-5.4	3.59 V	11	52.4	16.2
7	15720.00	50.8 AV	54.0	-3.2	3.59 V	11	34.6	16.2

Remarks:

1. Emission Level(dBuV/m) = Raw Value(dBuV) + Correction Factor(dB/m)
2. Correction Factor(dB/m) = Antenna Factor(dB/m) + Cable Factor(dB) – Pre-Amplifier Factor(dB)
3. The other emission levels were very low against the limit.
4. Margin value = Emission Level – Limit value
5. " * ": Fundamental frequency.
6. " # ": The radiated frequency is out of the restricted band.

CHANNEL	TX Channel 149	DETECTOR FUNCTION	Peak (PK)
FREQUENCY RANGE	1GHz ~ 40GHz		Average (AV)

ANTENNA POLARITY & TEST DISTANCE: HORIZONTAL AT 3 M								
NO.	FREQ. (MHz)	EMISSION LEVEL (dBuV/m)	LIMIT (dBuV/m)	MARGIN (dB)	ANTENNA HEIGHT (m)	TABLE ANGLE (Degree)	RAW VALUE (dBuV)	CORRECTION FACTOR (dB/m)
1	#5614.40	57.0 PK	68.2	-11.2	2.46 H	310	52.4	4.6
2	*5745.00	115.1 PK			2.46 H	310	75.0	40.1
3	*5745.00	104.4 AV			2.46 H	310	64.3	40.1
4	#5963.20	56.6 PK	68.2	-11.6	2.46 H	310	51.3	5.3
5	11490.00	61.1 PK	74.0	-12.9	1.88 H	42	43.1	18.0
6	11490.00	48.5 AV	54.0	-5.5	1.88 H	42	30.5	18.0
7	#17235.00	67.8 PK	68.2	-0.4	1.47 H	189	46.5	21.3

ANTENNA POLARITY & TEST DISTANCE: VERTICAL AT 3 M								
NO.	FREQ. (MHz)	EMISSION LEVEL (dBuV/m)	LIMIT (dBuV/m)	MARGIN (dB)	ANTENNA HEIGHT (m)	TABLE ANGLE (Degree)	RAW VALUE (dBuV)	CORRECTION FACTOR (dB/m)
1	#5613.60	57.2 PK	68.2	-11.0	3.84 V	355	52.6	4.6
2	*5745.00	114.6 PK			3.84 V	355	74.5	40.1
3	*5745.00	103.7 AV			3.84 V	355	63.6	40.1
4	#5930.40	56.9 PK	68.2	-11.3	3.84 V	355	51.6	5.3
5	11490.00	61.0 PK	74.0	-13.0	1.69 V	163	43.0	18.0
6	11490.00	48.1 AV	54.0	-5.9	1.69 V	163	30.1	18.0
7	#17235.00	67.6 PK	68.2	-0.6	2.01 V	197	46.3	21.3

Remarks:

1. Emission Level(dBuV/m) = Raw Value(dBuV) + Correction Factor(dB/m)
2. Correction Factor(dB/m) = Antenna Factor(dB/m) + Cable Factor(dB) – Pre-Amplifier Factor(dB)
3. The other emission levels were very low against the limit.
4. Margin value = Emission Level – Limit value
5. " * ": Fundamental frequency.
6. " # ": The radiated frequency is out of the restricted band.

CHANNEL	TX Channel 157	DETECTOR FUNCTION	Peak (PK)
FREQUENCY RANGE	1GHz ~ 40GHz		Average (AV)

ANTENNA POLARITY & TEST DISTANCE: HORIZONTAL AT 3 M								
NO.	FREQ. (MHz)	EMISSION LEVEL (dBuV/m)	LIMIT (dBuV/m)	MARGIN (dB)	ANTENNA HEIGHT (m)	TABLE ANGLE (Degree)	RAW VALUE (dBuV)	CORRECTION FACTOR (dB/m)
1	#5600.00	57.9 PK	68.2	-10.3	2.40 H	307	53.3	4.6
2	*5785.00	115.3 PK			2.40 H	307	75.0	40.3
3	*5785.00	104.8 AV			2.40 H	307	64.5	40.3
4	#5929.60	57.0 PK	68.2	-11.2	2.40 H	307	51.7	5.3
5	11570.00	58.3 PK	74.0	-15.7	2.03 H	44	40.6	17.7
6	11570.00	45.4 AV	54.0	-8.6	2.03 H	44	27.7	17.7
7	#17355.00	67.6 PK	68.2	-0.6	1.55 H	193	45.4	22.2

ANTENNA POLARITY & TEST DISTANCE: VERTICAL AT 3 M								
NO.	FREQ. (MHz)	EMISSION LEVEL (dBuV/m)	LIMIT (dBuV/m)	MARGIN (dB)	ANTENNA HEIGHT (m)	TABLE ANGLE (Degree)	RAW VALUE (dBuV)	CORRECTION FACTOR (dB/m)
1	#5610.40	57.5 PK	68.2	-10.7	3.75 V	339	52.9	4.6
2	*5785.00	115.3 PK			3.75 V	339	75.0	40.3
3	*5785.00	104.7 AV			3.75 V	339	64.4	40.3
4	#5941.60	57.3 PK	68.2	-10.9	3.75 V	339	52.0	5.3
5	11570.00	57.9 PK	74.0	-16.1	1.73 V	166	40.2	17.7
6	11570.00	45.2 AV	54.0	-8.8	1.73 V	166	27.5	17.7
7	#17355.00	67.3 PK	68.2	-0.9	1.98 V	220	45.1	22.2

Remarks:

1. Emission Level(dBuV/m) = Raw Value(dBuV) + Correction Factor(dB/m)
2. Correction Factor(dB/m) = Antenna Factor(dB/m) + Cable Factor(dB) – Pre-Amplifier Factor(dB)
3. The other emission levels were very low against the limit.
4. Margin value = Emission Level – Limit value
5. " * ": Fundamental frequency.
6. " # ": The radiated frequency is out of the restricted band.

CHANNEL	TX Channel 165	DETECTOR FUNCTION	Peak (PK)
FREQUENCY RANGE	1GHz ~ 40GHz		Average (AV)

ANTENNA POLARITY & TEST DISTANCE: HORIZONTAL AT 3 M								
NO.	FREQ. (MHz)	EMISSION LEVEL (dBuV/m)	LIMIT (dBuV/m)	MARGIN (dB)	ANTENNA HEIGHT (m)	TABLE ANGLE (Degree)	RAW VALUE (dBuV)	CORRECTION FACTOR (dB/m)
1	#5601.60	57.0 PK	68.2	-11.2	2.47 H	297	52.4	4.6
2	*5825.00	114.4 PK			2.47 H	297	74.0	40.4
3	*5825.00	103.6 AV			2.47 H	297	63.2	40.4
4	#5982.40	56.9 PK	68.2	-11.3	2.47 H	297	51.5	5.4
5	11650.00	59.1 PK	74.0	-14.9	1.81 H	39	41.6	17.5
6	11650.00	46.3 AV	54.0	-7.7	1.81 H	39	28.8	17.5
7	#17475.00	67.7 PK	68.2	-0.5	1.77 H	190	44.0	23.7

ANTENNA POLARITY & TEST DISTANCE: VERTICAL AT 3 M								
NO.	FREQ. (MHz)	EMISSION LEVEL (dBuV/m)	LIMIT (dBuV/m)	MARGIN (dB)	ANTENNA HEIGHT (m)	TABLE ANGLE (Degree)	RAW VALUE (dBuV)	CORRECTION FACTOR (dB/m)
1	#5609.60	57.0 PK	68.2	-11.2	3.67 V	336	52.4	4.6
2	*5825.00	114.6 PK			3.67 V	336	74.2	40.4
3	*5825.00	103.8 AV			3.67 V	336	63.4	40.4
4	#5983.20	59.0 PK	68.2	-9.2	3.67 V	336	53.6	5.4
5	11650.00	58.8 PK	74.0	-15.2	1.74 V	169	41.3	17.5
6	11650.00	45.9 AV	54.0	-8.1	1.74 V	169	28.4	17.5
7	#17475.00	67.6 PK	68.2	-0.6	1.79 V	210	43.9	23.7

Remarks:

1. Emission Level(dBuV/m) = Raw Value(dBuV) + Correction Factor(dB/m)
2. Correction Factor(dB/m) = Antenna Factor(dB/m) + Cable Factor(dB) – Pre-Amplifier Factor(dB)
3. The other emission levels were very low against the limit.
4. Margin value = Emission Level – Limit value
5. " * ": Fundamental frequency.
6. " # ": The radiated frequency is out of the restricted band.

802.11n (HT40)

CHANNEL	TX Channel 38	DETECTOR FUNCTION	Peak (PK) Average (AV)
FREQUENCY RANGE	1GHz ~ 40GHz		

ANTENNA POLARITY & TEST DISTANCE: HORIZONTAL AT 3 M								
NO.	FREQ. (MHz)	EMISSION LEVEL (dBuV/m)	LIMIT (dBuV/m)	MARGIN (dB)	ANTENNA HEIGHT (m)	TABLE ANGLE (Degree)	RAW VALUE (dBuV)	CORRECTION FACTOR (dB/m)
1	5150.00	70.8 PK	74.0	-3.2	2.13 H	295	66.4	4.4
2	5150.00	52.4 AV	54.0	-1.6	2.13 H	295	48.0	4.4
3	*5190.00	111.1 PK			2.31 H	293	71.6	39.5
4	*5190.00	101.0 AV			2.31 H	293	61.5	39.5
5	#10380.00	57.7 PK	68.2	-10.5	2.03 H	255	41.5	16.2
6	15570.00	63.9 PK	74.0	-10.1	2.09 H	221	47.0	16.9
7	15570.00	51.0 AV	54.0	-3.0	2.09 H	221	34.1	16.9
ANTENNA POLARITY & TEST DISTANCE: VERTICAL AT 3 M								
NO.	FREQ. (MHz)	EMISSION LEVEL (dBuV/m)	LIMIT (dBuV/m)	MARGIN (dB)	ANTENNA HEIGHT (m)	TABLE ANGLE (Degree)	RAW VALUE (dBuV)	CORRECTION FACTOR (dB/m)
1	5150.00	67.2 PK	74.0	-6.8	3.76 V	325	62.8	4.4
2	5150.00	50.0 AV	54.0	-4.0	3.76 V	325	45.6	4.4
3	*5190.00	109.8 PK			3.88 V	335	70.3	39.5
4	*5190.00	99.7 AV			3.88 V	335	60.2	39.5
5	#10380.00	57.4 PK	68.2	-10.8	1.79 V	351	41.2	16.2
6	15570.00	63.0 PK	74.0	-11.0	3.26 V	343	46.1	16.9
7	15570.00	49.9 AV	54.0	-4.1	3.26 V	343	33.0	16.9

Remarks:

1. Emission Level(dBuV/m) = Raw Value(dBuV) + Correction Factor(dB/m)
2. Correction Factor(dB/m) = Antenna Factor(dB/m) + Cable Factor(dB) – Pre-Amplifier Factor(dB)
3. The other emission levels were very low against the limit.
4. Margin value = Emission Level – Limit value
5. " * ": Fundamental frequency.
6. " # ": The radiated frequency is out of the restricted band.

CHANNEL	TX Channel 46	DETECTOR FUNCTION	Peak (PK)
FREQUENCY RANGE	1GHz ~ 40GHz		Average (AV)

ANTENNA POLARITY & TEST DISTANCE: HORIZONTAL AT 3 M								
NO.	FREQ. (MHz)	EMISSION LEVEL (dBuV/m)	LIMIT (dBuV/m)	MARGIN (dB)	ANTENNA HEIGHT (m)	TABLE ANGLE (Degree)	RAW VALUE (dBuV)	CORRECTION FACTOR (dB/m)
1	*5230.00	112.1 PK			2.19 H	285	72.8	39.3
2	*5230.00	101.7 AV			2.19 H	285	62.4	39.3
3	5350.00	56.2 PK	74.0	-17.8	2.46 H	270	51.9	4.3
4	5350.00	43.2 AV	54.0	-10.8	2.46 H	270	38.9	4.3
5	#10460.00	57.7 PK	68.2	-10.5	2.13 H	288	40.9	16.8
6	15690.00	67.9 PK	74.0	-6.1	2.34 H	244	51.5	16.4
7	15690.00	52.9 AV	54.0	-1.1	2.34 H	244	36.5	16.4

ANTENNA POLARITY & TEST DISTANCE: VERTICAL AT 3 M								
NO.	FREQ. (MHz)	EMISSION LEVEL (dBuV/m)	LIMIT (dBuV/m)	MARGIN (dB)	ANTENNA HEIGHT (m)	TABLE ANGLE (Degree)	RAW VALUE (dBuV)	CORRECTION FACTOR (dB/m)
1	*5230.00	110.9 PK			3.42 V	327	71.6	39.3
2	*5230.00	100.5 AV			3.42 V	327	61.2	39.3
3	5350.00	56.5 PK	74.0	-17.5	3.33 V	347	52.2	4.3
4	5350.00	43.0 AV	54.0	-11.0	3.33 V	347	38.7	4.3
5	#10460.00	58.5 PK	68.2	-9.7	1.75 V	337	41.7	16.8
6	15690.00	62.3 PK	74.0	-11.7	3.36 V	327	45.9	16.4
7	15690.00	48.9 AV	54.0	-5.1	3.36 V	327	32.5	16.4

Remarks:

1. Emission Level(dBuV/m) = Raw Value(dBuV) + Correction Factor(dB/m)
2. Correction Factor(dB/m) = Antenna Factor(dB/m) + Cable Factor(dB) – Pre-Amplifier Factor(dB)
3. The other emission levels were very low against the limit.
4. Margin value = Emission Level – Limit value
5. " * ": Fundamental frequency.
6. " # ": The radiated frequency is out of the restricted band.

CHANNEL	TX Channel 151	DETECTOR FUNCTION	Peak (PK)
FREQUENCY RANGE	1GHz ~ 40GHz		Average (AV)

ANTENNA POLARITY & TEST DISTANCE: HORIZONTAL AT 3 M								
NO.	FREQ. (MHz)	EMISSION LEVEL (dBuV/m)	LIMIT (dBuV/m)	MARGIN (dB)	ANTENNA HEIGHT (m)	TABLE ANGLE (Degree)	RAW VALUE (dBuV)	CORRECTION FACTOR (dB/m)
1	#5606.40	56.9 PK	68.2	-11.3	2.31 H	312	52.3	4.6
2	*5755.00	112.4 PK			2.31 H	312	72.3	40.1
3	*5755.00	102.9 AV			2.31 H	312	62.8	40.1
4	#5986.40	57.8 PK	68.2	-10.4	2.31 H	312	52.4	5.4
5	11510.00	59.2 PK	74.0	-14.8	2.05 H	39	41.1	18.1
6	11510.00	45.4 AV	54.0	-8.6	2.05 H	39	27.3	18.1
7	#17265.00	67.4 PK	68.2	-0.8	3.01 H	228	46.3	21.1

ANTENNA POLARITY & TEST DISTANCE: VERTICAL AT 3 M								
NO.	FREQ. (MHz)	EMISSION LEVEL (dBuV/m)	LIMIT (dBuV/m)	MARGIN (dB)	ANTENNA HEIGHT (m)	TABLE ANGLE (Degree)	RAW VALUE (dBuV)	CORRECTION FACTOR (dB/m)
1	#5613.60	58.0 PK	68.2	-10.2	3.81 V	358	53.4	4.6
2	*5755.00	111.9 PK			3.81 V	358	71.8	40.1
3	*5755.00	101.6 AV			3.81 V	358	61.5	40.1
4	#5992.00	57.7 PK	68.2	-10.5	3.81 V	358	52.3	5.4
5	11510.00	59.0 PK	74.0	-15.0	1.74 V	166	40.9	18.1
6	11510.00	45.1 AV	54.0	-8.9	1.74 V	166	27.0	18.1
7	#17265.00	67.0 PK	68.2	-1.2	1.91 V	210	45.9	21.1

Remarks:

1. Emission Level(dBuV/m) = Raw Value(dBuV) + Correction Factor(dB/m)
2. Correction Factor(dB/m) = Antenna Factor(dB/m) + Cable Factor(dB) – Pre-Amplifier Factor(dB)
3. The other emission levels were very low against the limit.
4. Margin value = Emission Level – Limit value
5. " * ": Fundamental frequency.
6. " # ": The radiated frequency is out of the restricted band.

CHANNEL	TX Channel 159	DETECTOR FUNCTION	Peak (PK)
FREQUENCY RANGE	1GHz ~ 40GHz		Average (AV)

ANTENNA POLARITY & TEST DISTANCE: HORIZONTAL AT 3 M								
NO.	FREQ. (MHz)	EMISSION LEVEL (dBuV/m)	LIMIT (dBuV/m)	MARGIN (dB)	ANTENNA HEIGHT (m)	TABLE ANGLE (Degree)	RAW VALUE (dBuV)	CORRECTION FACTOR (dB/m)
1	#5600.00	57.8 PK	68.2	-10.4	2.37 H	304	53.2	4.6
2	*5795.00	111.8 PK			2.37 H	304	71.4	40.4
3	*5795.00	101.4 AV			2.37 H	304	61.0	40.4
4	#5946.40	57.1 PK	68.2	-11.1	2.37 H	304	51.8	5.3
5	11590.00	58.7 PK	74.0	-15.3	1.87 H	71	41.1	17.6
6	11590.00	45.0 AV	54.0	-9.0	1.87 H	71	27.4	17.6
7	#17385.00	67.9 PK	68.2	-0.3	1.99 H	195	45.0	22.9

ANTENNA POLARITY & TEST DISTANCE: VERTICAL AT 3 M								
NO.	FREQ. (MHz)	EMISSION LEVEL (dBuV/m)	LIMIT (dBuV/m)	MARGIN (dB)	ANTENNA HEIGHT (m)	TABLE ANGLE (Degree)	RAW VALUE (dBuV)	CORRECTION FACTOR (dB/m)
1	#5604.00	57.0 PK	68.2	-11.2	3.76 V	0	52.4	4.6
2	*5795.00	110.6 PK			3.76 V	0	70.2	40.4
3	*5795.00	100.8 AV			3.76 V	0	60.4	40.4
4	#5988.80	56.9 PK	68.2	-11.3	3.76 V	0	51.5	5.4
5	11590.00	58.4 PK	74.0	-15.6	1.85 V	165	40.8	17.6
6	11590.00	44.7 AV	54.0	-9.3	1.85 V	165	27.1	17.6
7	#17385.00	67.4 PK	68.2	-0.8	1.84 V	201	44.5	22.9

Remarks:

1. Emission Level(dBuV/m) = Raw Value(dBuV) + Correction Factor(dB/m)
2. Correction Factor(dB/m) = Antenna Factor(dB/m) + Cable Factor(dB) – Pre-Amplifier Factor(dB)
3. The other emission levels were very low against the limit.
4. Margin value = Emission Level – Limit value
5. " * ": Fundamental frequency.
6. " # ": The radiated frequency is out of the restricted band.

802.11ac (VHT80)

CHANNEL	TX Channel 42	DETECTOR FUNCTION	Peak (PK)
FREQUENCY RANGE	1GHz ~ 40GHz		Average (AV)

ANTENNA POLARITY & TEST DISTANCE: HORIZONTAL AT 3 M

NO.	FREQ. (MHz)	EMISSION LEVEL (dBuV/m)	LIMIT (dBuV/m)	MARGIN (dB)	ANTENNA HEIGHT (m)	TABLE ANGLE (Degree)	RAW VALUE (dBuV)	CORRECTION FACTOR (dB/m)
1	5150.00	68.9 PK	74.0	-5.1	2.63 H	293	64.5	4.4
2	5150.00	52.6 AV	54.0	-1.4	2.63 H	293	48.2	4.4
3	*5210.00	107.7 PK			2.11 H	295	68.3	39.4
4	*5210.00	97.7 AV			2.11 H	295	58.3	39.4
5	5350.00	56.8 PK	74.0	-17.2	2.81 H	278	52.5	4.3
6	5350.00	43.6 AV	54.0	-10.4	2.81 H	278	39.3	4.3
7	#10420.00	58.0 PK	68.2	-10.2	1.87 H	301	41.5	16.5
8	15630.00	63.3 PK	74.0	-10.7	2.25 H	216	46.5	16.8
9	15630.00	49.9 AV	54.0	-4.1	2.25 H	216	33.1	16.8

ANTENNA POLARITY & TEST DISTANCE: VERTICAL AT 3 M

NO.	FREQ. (MHz)	EMISSION LEVEL (dBuV/m)	LIMIT (dBuV/m)	MARGIN (dB)	ANTENNA HEIGHT (m)	TABLE ANGLE (Degree)	RAW VALUE (dBuV)	CORRECTION FACTOR (dB/m)
1	5150.00	66.6 PK	74.0	-7.4	3.57 V	341	62.2	4.4
2	5150.00	51.1 AV	54.0	-2.9	3.57 V	341	46.7	4.4
3	*5210.00	106.9 PK			3.42 V	326	67.5	39.4
4	*5210.00	96.4 AV			3.42 V	326	57.0	39.4
5	5350.00	56.7 PK	74.0	-17.3	3.63 V	350	52.4	4.3
6	5350.00	43.0 AV	54.0	-11.0	3.63 V	350	38.7	4.3
7	#10420.00	57.6 PK	68.2	-10.6	1.81 V	346	41.1	16.5
8	15630.00	62.7 PK	74.0	-11.3	3.09 V	333	45.9	16.8
9	15630.00	49.2 AV	54.0	-4.8	3.09 V	333	32.4	16.8

Remarks:

1. Emission Level(dBuV/m) = Raw Value(dBuV) + Correction Factor(dB/m)
2. Correction Factor(dB/m) = Antenna Factor(dB/m) + Cable Factor(dB) – Pre-Amplifier Factor(dB)
3. The other emission levels were very low against the limit.
4. Margin value = Emission Level – Limit value
5. " * ": Fundamental frequency.
6. " # ": The radiated frequency is out of the restricted band.

CHANNEL	TX Channel 155	DETECTOR FUNCTION	Peak (PK)
FREQUENCY RANGE	1GHz ~ 40GHz		Average (AV)

ANTENNA POLARITY & TEST DISTANCE: HORIZONTAL AT 3 M

NO.	FREQ. (MHz)	EMISSION LEVEL (dBuV/m)	LIMIT (dBuV/m)	MARGIN (dB)	ANTENNA HEIGHT (m)	TABLE ANGLE (Degree)	RAW VALUE (dBuV)	CORRECTION FACTOR (dB/m)
1	#5624.00	57.4 PK	68.2	-10.8	2.32 H	299	52.9	4.5
2	#5650.00	61.7 PK	68.2	-6.5	2.59 H	316	57.2	4.5
3	*5775.00	107.4 PK			2.32 H	299	67.1	40.3
4	*5775.00	97.4 AV			2.32 H	299	57.1	40.3
5	#5925.00	62.0 PK	68.2	-6.2	2.14 H	292	56.7	5.3
6	#5977.60	57.8 PK	68.2	-10.4	2.32 H	299	52.4	5.4
7	11550.00	58.6 PK	74.0	-15.4	1.87 H	51	40.7	17.9
8	11550.00	45.2 AV	54.0	-8.8	1.87 H	51	27.3	17.9
9	#17325.00	67.4 PK	68.2	-0.8	1.71 H	189	46.0	21.4

ANTENNA POLARITY & TEST DISTANCE: VERTICAL AT 3 M

NO.	FREQ. (MHz)	EMISSION LEVEL (dBuV/m)	LIMIT (dBuV/m)	MARGIN (dB)	ANTENNA HEIGHT (m)	TABLE ANGLE (Degree)	RAW VALUE (dBuV)	CORRECTION FACTOR (dB/m)
1	#5620.80	56.8 PK	68.2	-11.4	3.74 V	339	52.2	4.6
2	#5650.00	59.0 PK	68.2	-9.2	3.57 V	350	54.5	4.5
3	*5775.00	107.7 PK			3.74 V	339	67.4	40.3
4	*5775.00	97.7 AV			3.74 V	339	57.4	40.3
5	#5925.00	59.6 PK	68.2	-8.6	3.61 V	343	54.3	5.3
6	#5928.00	57.8 PK	68.2	-10.4	3.74 V	339	52.5	5.3
7	11550.00	57.6 PK	74.0	-16.4	1.85 V	321	39.7	17.9
8	11550.00	45.0 AV	54.0	-9.0	1.85 V	321	27.1	17.9
9	#17325.00	67.3 PK	68.2	-0.9	1.91 V	207	45.9	21.4

Remarks:

1. Emission Level(dBuV/m) = Raw Value(dBuV) + Correction Factor(dB/m)
2. Correction Factor(dB/m) = Antenna Factor(dB/m) + Cable Factor(dB) – Pre-Amplifier Factor(dB)
3. The other emission levels were very low against the limit.
4. Margin value = Emission Level – Limit value
5. " * ": Fundamental frequency.
6. " # ": The radiated frequency is out of the restricted band.

Below 1GHz Worst-Case

802.11n (HT20)

CHANNEL	TX Channel 157	DETECTOR FUNCTION	Quasi-Peak (QP)
FREQUENCY RANGE	9kHz ~ 1GHz	TEST MODE	A

ANTENNA POLARITY & TEST DISTANCE: HORIZONTAL AT 3 M								
NO.	FREQ. (MHz)	EMISSION LEVEL (dBuV/m)	LIMIT (dBuV/m)	MARGIN (dB)	ANTENNA HEIGHT (m)	TABLE ANGLE (Degree)	RAW VALUE (dBuV)	CORRECTION FACTOR (dB/m)
1	57.21	26.8 QP	40.0	-13.2	2.00 H	48	36.9	-10.1
2	74.71	27.1 QP	40.0	-12.9	2.00 H	48	39.9	-12.8
3	154.41	26.2 QP	43.5	-17.3	1.01 H	227	35.3	-9.1
4	216.61	29.0 QP	46.0	-17.0	1.01 H	71	39.9	-10.9
5	228.28	26.1 QP	46.0	-19.9	1.50 H	80	36.6	-10.5
6	593.73	29.1 QP	46.0	-16.9	2.00 H	162	30.5	-1.4

Remarks:

1. Emission Level(dBuV/m) = Raw Value(dBuV) + Correction Factor(dB/m)
2. Correction Factor(dB/m) = Antenna Factor(dB/m) + Cable Factor(dB) – Pre-Amplifier Factor(dB)
3. Margin value = Emission Level – Limit value
4. The emission levels were very low against the limit of frequency range 9kHz~30MHz: the amplitude of spurious emissions attenuated more than 20dB below the permissible value to be report.

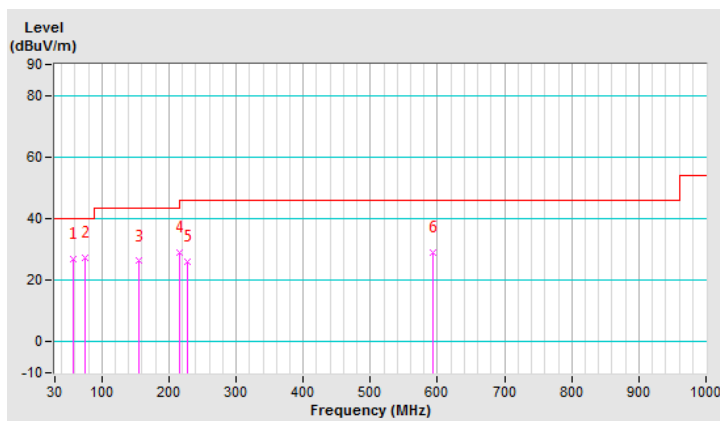

CHANNEL	TX Channel 157	DETECTOR FUNCTION	Quasi-Peak (QP)
FREQUENCY RANGE	9kHz ~ 1GHz	TEST MODE	A

ANTENNA POLARITY & TEST DISTANCE: VERTICAL AT 3 M

NO.	FREQ. (MHz)	EMISSION LEVEL (dBuV/m)	LIMIT (dBuV/m)	MARGIN (dB)	ANTENNA HEIGHT (m)	TABLE ANGLE (Degree)	RAW VALUE (dBuV)	CORRECTION FACTOR (dB/m)
1	59.16	34.7 QP	40.0	-5.3	1.00 V	10	44.8	-10.1
2	70.82	35.5 QP	40.0	-4.5	1.00 V	329	47.5	-12.0
3	109.70	28.7 QP	43.5	-14.8	1.50 V	5	41.2	-12.5
4	162.18	28.7 QP	43.5	-14.8	1.00 V	162	37.7	-9.0
5	208.84	29.3 QP	43.5	-14.2	1.00 V	177	40.3	-11.0
6	315.75	28.2 QP	46.0	-17.8	1.99 V	17	35.2	-7.0

Remarks:

1. Emission Level(dBuV/m) = Raw Value(dBuV) + Correction Factor(dB/m)
2. Correction Factor(dB/m) = Antenna Factor(dB/m) + Cable Factor(dB) – Pre-Amplifier Factor(dB)
3. Margin value = Emission Level – Limit value
4. The emission levels were very low against the limit of frequency range 9kHz~30MHz: the amplitude of spurious emissions attenuated more than 20dB below the permissible value to be report.

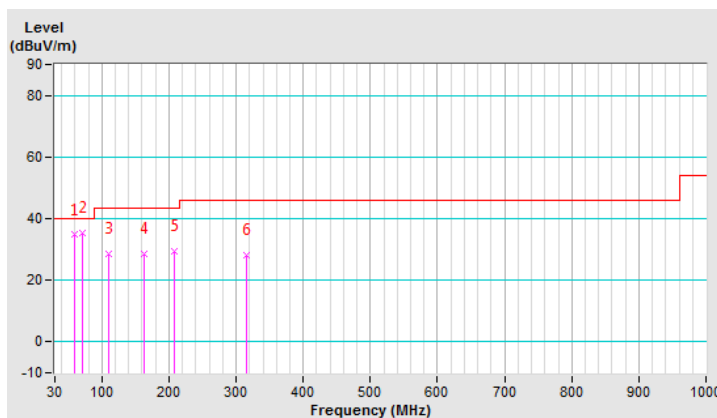

CHANNEL	TX Channel 157	DETECTOR FUNCTION	Quasi-Peak (QP)
FREQUENCY RANGE	9kHz ~ 1GHz	TEST MODE	B

ANTENNA POLARITY & TEST DISTANCE: HORIZONTAL AT 3 M								
NO.	FREQ. (MHz)	EMISSION LEVEL (dBuV/m)	LIMIT (dBuV/m)	MARGIN (dB)	ANTENNA HEIGHT (m)	TABLE ANGLE (Degree)	RAW VALUE (dBuV)	CORRECTION FACTOR (dB/m)
1	57.16	26.6 QP	40.0	-13.4	1.99 H	213	36.7	-10.1
2	70.74	23.1 QP	40.0	-16.9	1.99 H	259	35.1	-12.0
3	154.16	30.2 QP	43.5	-13.3	1.99 H	79	39.2	-9.0
4	245.34	32.3 QP	46.0	-13.7	1.00 H	180	41.6	-9.3
5	272.50	30.7 QP	46.0	-15.3	1.00 H	10	38.9	-8.2
6	322.94	24.1 QP	46.0	-21.9	1.49 H	118	31.0	-6.9

Remarks:

1. Emission Level(dBuV/m) = Raw Value(dBuV) + Correction Factor(dB/m)
2. Correction Factor(dB/m) = Antenna Factor(dB/m) + Cable Factor(dB) – Pre-Amplifier Factor(dB)
3. Margin value = Emission Level – Limit value
4. The emission levels were very low against the limit of frequency range 9kHz~30MHz: the amplitude of spurious emissions attenuated more than 20dB below the permissible value to be report.

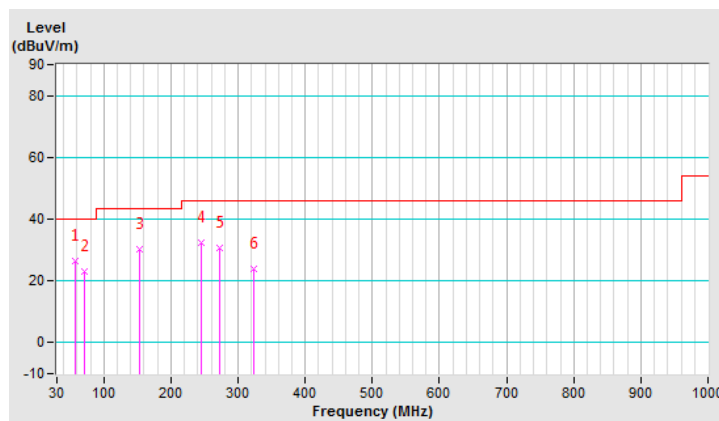

CHANNEL	TX Channel 157	DETECTOR FUNCTION	Quasi-Peak (QP)
FREQUENCY RANGE	9kHz ~ 1GHz	TEST MODE	B

ANTENNA POLARITY & TEST DISTANCE: VERTICAL AT 3 M

NO.	FREQ. (MHz)	EMISSION LEVEL (dBuV/m)	LIMIT (dBuV/m)	MARGIN (dB)	ANTENNA HEIGHT (m)	TABLE ANGLE (Degree)	RAW VALUE (dBuV)	CORRECTION FACTOR (dB/m)
1	57.16	22.4 QP	40.0	-17.6	1.51 V	21	32.5	-10.1
2	134.76	23.6 QP	43.5	-19.9	1.01 V	202	33.7	-10.1
3	144.46	24.9 QP	43.5	-18.6	1.01 V	313	34.2	-9.3
4	249.22	28.6 QP	46.0	-17.4	2.00 V	109	37.7	-9.1
5	276.38	27.8 QP	46.0	-18.2	2.00 V	124	35.9	-8.1
6	443.22	30.5 QP	46.0	-15.5	1.51 V	65	34.9	-4.4

Remarks:

1. Emission Level(dBuV/m) = Raw Value(dBuV) + Correction Factor(dB/m)
2. Correction Factor(dB/m) = Antenna Factor(dB/m) + Cable Factor(dB) – Pre-Amplifier Factor(dB)
3. Margin value = Emission Level – Limit value
4. The emission levels were very low against the limit of frequency range 9kHz~30MHz: the amplitude of spurious emissions attenuated more than 20dB below the permissible value to be report.

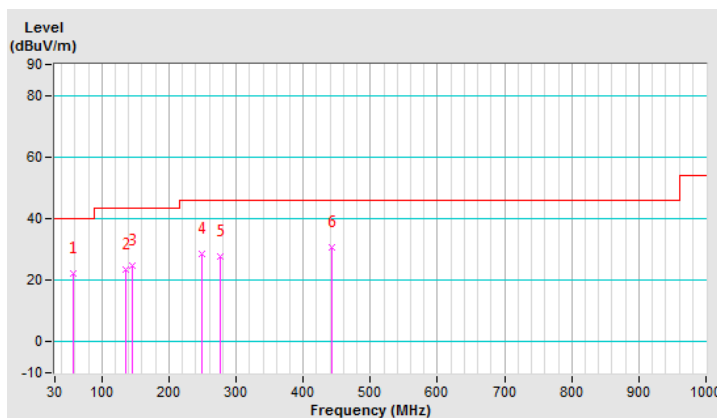

4.2 Conducted Emission Measurement

4.2.1 Limits of Conducted Emission Measurement

Frequency (MHz)	Conducted Limit (dBuV)	
	Quasi-peak	Average
0.15 - 0.5	66 - 56	56 - 46
0.50 - 5.0	56	46
5.0 - 30.0	60	50

Note: 1. The lower limit shall apply at the transition frequencies.

2. The limit decreases in line with the logarithm of the frequency in the range of 0.15 to 0.50MHz.

4.2.2 Test Instruments

Description & Manufacturer	Model No.	Serial No.	Cal. Date	Cal. Due
Test Receiver ROHDE & SCHWARZ	ESCI	100613	Dec. 10, 2018	Dec. 09, 2019
RF signal cable Woken	5D-FB	Cable-cond1-01	Sep. 05, 2018	Sep. 04, 2019
LISN ROHDE & SCHWARZ (EUT)	ENV216	101826	Feb. 21, 2019	Feb. 20, 2020
LISN ROHDE & SCHWARZ (Peripheral)	ESH3-Z5	100311	Aug. 19, 2018	Aug. 18, 2019
Software ADT	BV ADT_Cond_ V7.3.7.4	NA	NA	NA

Note: 1. The calibration interval of the above test instruments is 12 months and the calibrations are traceable to NML/ROC and NIST/USA.

2. The test was performed in HwaYa Shielded Room 1.

3. The VCCI Site Registration No. is C-12040.

4.2.3 Test Procedures

- The EUT was placed 0.4 meters from the conducting wall of the shielded room with EUT being connected to the power mains through a line impedance stabilization network (LISN). Other support units were connected to the power mains through another LISN. The two LISNs provide 50 ohm/ 50uH of coupling impedance for the measuring instrument.
- Both lines of the power mains connected to the EUT were checked for maximum conducted interference.
- The frequency range from 150kHz to 30MHz was searched. Emission levels under (Limit - 20dB) was not recorded.

NOTE: The resolution bandwidth and video bandwidth of test receiver is 9kHz for quasi-peak detection (QP) and average detection (AV) at frequency 0.15MHz-30MHz.

4.2.4 Deviation from Test Standard

No deviation.

4.2.5 Test Setup

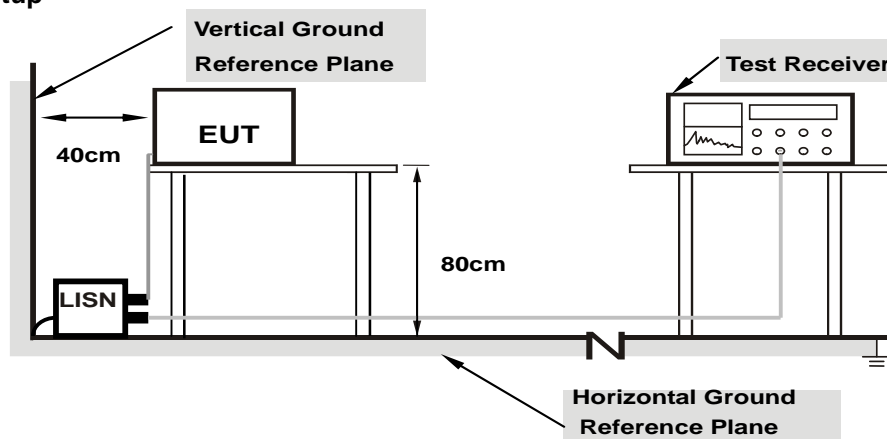

Note: 1.Support units were connected to second LISN.

For the actual test configuration, please refer to the attached file (Test Setup Photo).

4.2.6 EUT Operating Conditions

Same as 4.1.6.

4.2.7 Test Results

Worst-case data:

802.11n (HT20)

Phase	Line (L)	Detector Function	Quasi-Peak (QP) / Average (AV)
Channel	TX Channel 157	Test Mode	A

No	Freq. [MHz]	Corr. Factor (dB)	Reading Value [dB (uV)]		Emission Level [dB (uV)]		Limit [dB (uV)]		Margin (dB)	
			Q.P.	AV.	Q.P.	AV.	Q.P.	AV.	Q.P.	AV.
			1	0.15391	9.69	36.81	27.79	46.50	37.48	65.79
2	0.16569	9.69	34.99	25.04	44.68	34.73	65.17	55.17	-20.49	-20.44
3	0.51043	9.68	37.92	30.91	47.60	40.59	56.00	46.00	-8.40	-5.41
4	1.43639	9.68	24.65	17.26	34.33	26.94	56.00	46.00	-21.67	-19.06
5	1.83912	9.70	24.47	17.64	34.17	27.34	56.00	46.00	-21.83	-18.66
6	13.79199	9.90	14.97	9.21	24.87	19.11	60.00	50.00	-35.13	-30.89

REMARKS:

1. Q.P. and AV. are abbreviations of quasi-peak and average individually.
2. The emission levels of other frequencies were very low against the limit.
3. Margin value = Emission level - Limit value
4. Correction factor = Insertion loss + Cable loss
5. Emission Level = Correction Factor + Reading Value.

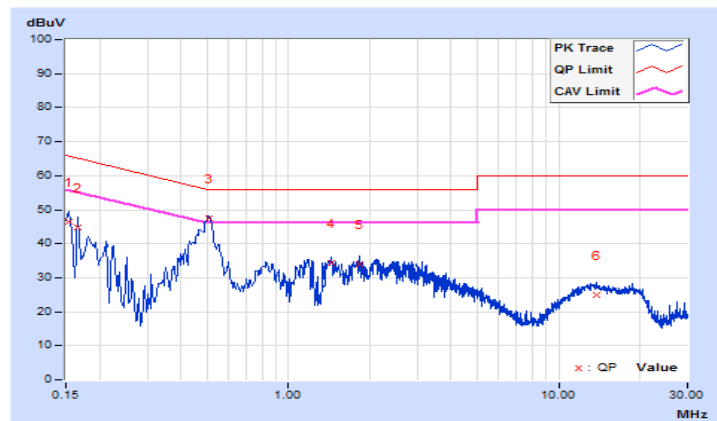

Phase	Neutral (N)	Detector Function	Quasi-Peak (QP) / Average (AV)
Channel	TX Channel 157	Test Mode	A

No	Freq. [MHz]	Corr. Factor (dB)	Reading Value [dB (uV)]		Emission Level [dB (uV)]		Limit [dB (uV)]		Margin (dB)	
			Q.P.	AV.	Q.P.	AV.	Q.P.	AV.	Q.P.	AV.
			1	0.16967	9.66	36.54	25.08	46.20	34.74	64.98
2	0.21647	9.66	28.76	17.03	38.42	26.69	62.95	52.95	-24.53	-26.26
3	0.49408	9.65	37.68	30.94	47.33	40.59	56.10	46.10	-8.77	-5.51
4	1.45594	9.65	24.28	16.29	33.93	25.94	56.00	46.00	-22.07	-20.06
5	2.15583	9.67	23.37	15.61	33.04	25.28	56.00	46.00	-22.96	-20.72
6	16.25529	9.95	14.40	9.43	24.35	19.38	60.00	50.00	-35.65	-30.62

REMARKS:

1. Q.P. and AV. are abbreviations of quasi-peak and average individually.
2. The emission levels of other frequencies were very low against the limit.
3. Margin value = Emission level - Limit value
4. Correction factor = Insertion loss + Cable loss
5. Emission Level = Correction Factor + Reading Value.

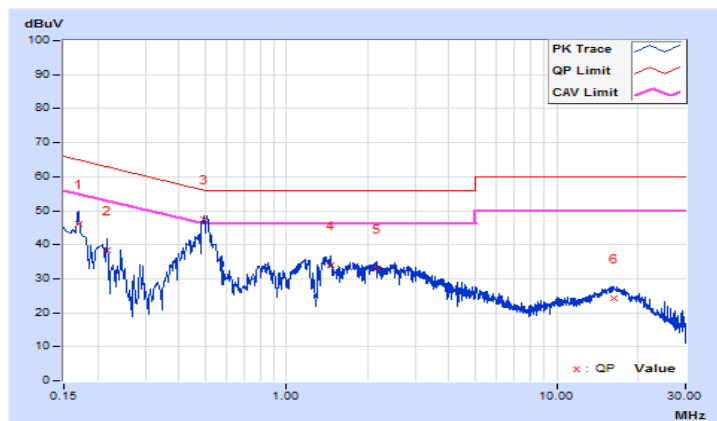

Phase	Line (L)	Detector Function	Quasi-Peak (QP) / Average (AV)
Channel	TX Channel 157	Test Mode	B

No	Freq. [MHz]	Corr. Factor (dB)	Reading Value [dB (uV)]		Emission Level [dB (uV)]		Limit [dB (uV)]		Margin (dB)	
			Q.P.	AV.	Q.P.	AV.	Q.P.	AV.	Q.P.	AV.
			1	0.15391	9.69	40.99	26.57	50.68	36.26	65.79
2	0.16955	9.69	38.10	22.13	47.79	31.82	64.98	54.98	-17.19	-23.16
3	0.51312	9.68	36.02	31.99	45.70	41.67	56.00	46.00	-10.30	-4.33
4	3.19980	9.73	24.41	19.54	34.14	29.27	56.00	46.00	-21.86	-16.73
5	10.80866	9.88	27.85	22.59	37.73	32.47	60.00	50.00	-22.27	-17.53
6	21.42431	9.93	20.53	17.46	30.46	27.39	60.00	50.00	-29.54	-22.61

REMARKS:

1. Q.P. and AV. are abbreviations of quasi-peak and average individually.
2. The emission levels of other frequencies were very low against the limit.
3. Margin value = Emission level - Limit value
4. Correction factor = Insertion loss + Cable loss
5. Emission Level = Correction Factor + Reading Value.

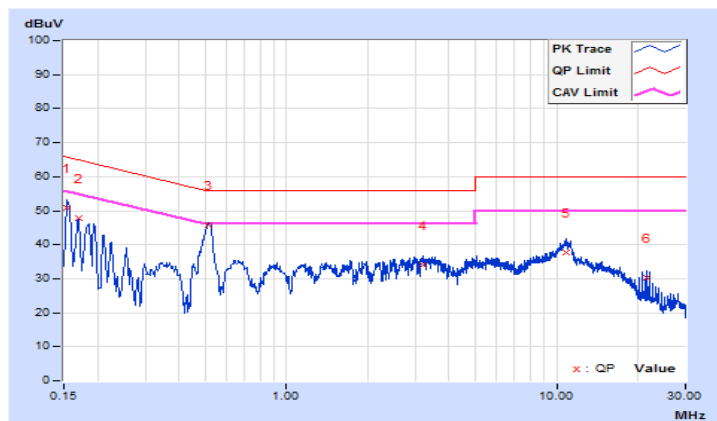

Phase	Neutral (N)	Detector Function	Quasi-Peak (QP) / Average (AV)
Channel	TX Channel 157	Test Mode	B

No	Freq. [MHz]	Corr. Factor (dB)	Reading Value [dB (uV)]		Emission Level [dB (uV)]		Limit [dB (uV)]		Margin (dB)	
			Q.P.	AV.	Q.P.	AV.	Q.P.	AV.	Q.P.	AV.
			1	0.15000	9.66	42.59	25.76	52.25	35.42	66.00
2	0.19301	9.66	35.18	18.80	44.84	28.46	63.91	53.91	-19.07	-25.45
3	0.52130	9.65	35.73	30.39	45.38	40.04	56.00	46.00	-10.62	-5.96
4	4.82245	9.74	20.85	14.65	30.59	24.39	56.00	46.00	-25.41	-21.61
5	11.14492	9.87	25.68	20.50	35.55	30.37	60.00	50.00	-24.45	-19.63
6	21.42040	10.01	21.37	18.24	31.38	28.25	60.00	50.00	-28.62	-21.75

REMARKS:

1. Q.P. and AV. are abbreviations of quasi-peak and average individually.
2. The emission levels of other frequencies were very low against the limit.
3. Margin value = Emission level - Limit value
4. Correction factor = Insertion loss + Cable loss
5. Emission Level = Correction Factor + Reading Value.

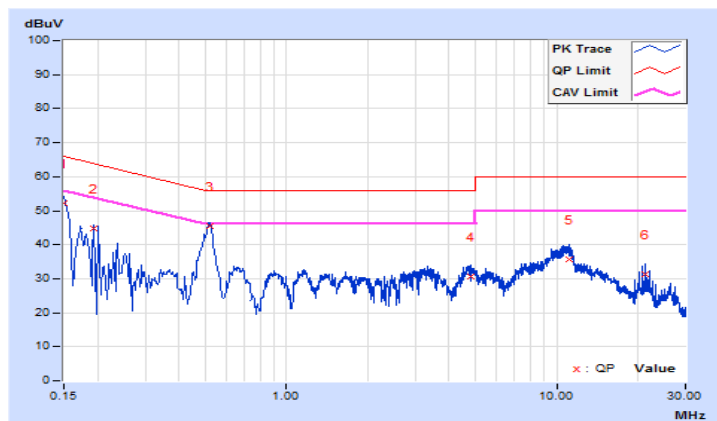

4.3 Transmit Power Measurement

4.3.1 Limits of Transmit Power Measurement

Operation Band	EUT Category		LIMIT
U-NII-1	-	Outdoor Access Point	1 Watt (30 dBm) (Max. e.i.r.p \leq 125mW(21 dBm) at any elevation angle above 30 degrees as measured from the horizon)
	-	Fixed point-to-point Access Point	1 Watt (30 dBm)
	√	Indoor Access Point	1 Watt (30 dBm)
	-	Mobile and Portable client device	250mW (24 dBm)
U-NII-2A	-		250mW (24 dBm) or 11 dBm+10 log B*
U-NII-2C	-		250mW (24 dBm) or 11 dBm+10 log B*
U-NII-3	√		1 Watt (30 dBm)

*B is the 26 dB emission bandwidth in megahertz

Per KDB 662911 Method of conducted output power measurement on IEEE 802.11 devices,

Array Gain = 0 dB (i.e., no array gain) for $N_{ANT} \leq 4$;

Array Gain = 0 dB (i.e., no array gain) for channel widths ≥ 40 MHz for any N_{ANT} ;

Array Gain = $5 \log(N_{ANT}/N_{SS})$ dB or 3 dB, whichever is less for 20-MHz channel widths with $N_{ANT} \geq 5$.

For power measurements on all other devices: Array Gain = $10 \log(N_{ANT}/N_{SS})$ dB.

4.3.2 Test Setup

For Power Output
 802.11a, 802.11n (HT20), 802.11n (HT40)

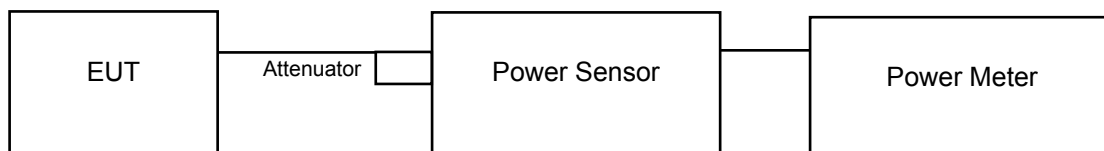

802.11ac (VHT80)

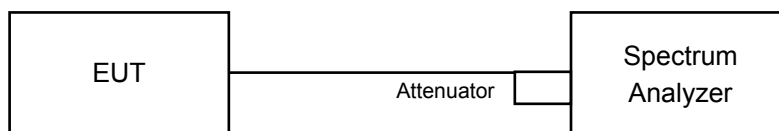

For Bandwidth

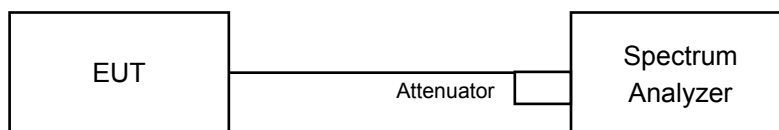

4.3.3 Test Instruments

Refer to section 4.1.2 to get information of above instrument.

4.3.4 Test Procedure

For Average Power Measurement

For 802.11a, 802.11n (HT20), 802.11n (HT40)

Method PM is used to perform output power measurement, trigger and gating function of wide band power meter is enabled to measure max output power of TX on burst and set the detector to AVERAGE. Duty factor is not added to measured value.

For 802.11ac (VHT80)

- 1) Set span to encompass the entire 26 dB EBW (or, alternatively, the entire 99% occupied bandwidth) of the signal.
- 2) Set sweep trigger to "free run".
- 3) Set RBW = 1 MHz.
- 4) Set VBW \geq 3 MHz.
- 5) Number of points in sweep \geq 2 Span / RBW.
- 6) Sweep time \leq (number of points in sweep) * T
- 7) Using emission bandwidth to determine the frequency span for integration the channel bandwidth.
- 8) Detector = RMS.
- 9) Trace mode = max hold.
- 10) Allow max hold to run for at least 60 seconds, or longer as needed to allow the trace to stabilize.
- 11) Compute power by integrating the spectrum across the EBW (or, alternatively, the entire 99% occupied bandwidth) of the signal using the instrument's band power measurement function with band limits set equal to the EBW (or occupied bandwidth) band edges. If the instrument does not have a band power function, sum the spectrum levels (in power units) at 1 MHz intervals extending across the EBW (or, alternatively, the entire 99% occupied bandwidth) of the spectrum.

For 26dB Bandwidth

- 1) Set RBW = approximately 1% of the emission bandwidth.
- 2) Set the VBW > RBW.
- 3) Detector = Peak.
- 4) Trace mode = max hold.
- 5) Measure the maximum width of the emission that is 26 dB down from the peak of the emission. Compare this with the RBW setting of the analyzer. Readjust RBW and repeat measurement as needed until the RBW/EBW ratio is approximately 1%.

4.3.5 Deviation from Test Standard

No deviation.

4.3.6 EUT Operating Conditions

The software provided by client to enable the EUT under transmission condition continuously at lowest, middle and highest channel frequencies individually.

4.3.7 Test Result

Power Output:

CDD Mode

802.11a

Chan.	Freq. (MHz)	Maximum Conducted Power (dBm)		Total Power (mW)	Total Power (dBm)	Power Limit (dBm)	Pass / Fail
		Chain 0	Chain 1				
36	5180	19.17	19.43	170.304	22.31	30	Pass
40	5200	19.15	19.49	171.144	22.33	30	Pass
48	5240	19.47	19.95	187.367	22.73	30	Pass
149	5745	22.15	20.52	276.779	24.42	30	Pass
157	5785	22.42	21.19	306.104	24.86	30	Pass
165	5825	21.05	20.42	237.504	23.76	30	Pass

802.11n (HT20)

Chan.	Freq. (MHz)	Maximum Conducted Power (dBm)		Total Power (mW)	Total Power (dBm)	Power Limit (dBm)	Pass / Fail
		Chain 0	Chain 1				
36	5180	19.07	19.82	176.664	22.47	30	Pass
40	5200	18.77	19.25	159.476	22.03	30	Pass
48	5240	19.48	20.25	194.641	22.89	30	Pass
149	5745	22.41	20.81	294.685	24.69	30	Pass
157	5785	22.61	21.44	321.706	25.07	30	Pass
165	5825	20.13	20.45	213.956	23.30	30	Pass

802.11n (HT40)

Chan.	Freq. (MHz)	Maximum Conducted Power (dBm)		Total Power (mW)	Total Power (dBm)	Power Limit (dBm)	Pass / Fail
		Chain 0	Chain 1				
38	5190	18.69	18.92	151.944	21.82	30	Pass
46	5230	20.03	19.77	195.535	22.91	30	Pass
151	5755	21.65	20.13	249.257	23.97	30	Pass
159	5795	20.81	19.62	212.126	23.27	30	Pass

802.11ac (VHT80)

Chan.	Freq. (MHz)	Maximum Conducted Power (dBm)		Total Power (mW)	Total Power (dBm)	Power Limit (dBm)	Pass / Fail
		Chain 0	Chain 1				
42	5210	19.25	19.69	177.251	22.49	30	Pass
155	5775	20.89	19.67	215.427	23.33	30	Pass

Beamforming Mode

802.11n (HT20)

Chan.	Freq. (MHz)	Maximum Conducted Power (dBm)		Total Power (mW)	Total Power (dBm)	Power Limit (dBm)	Pass / Fail
		Chain 0	Chain 1				
36	5180	16.06	16.81	88.338	19.46	27.37	Pass
40	5200	15.76	16.24	79.743	19.02	27.37	Pass
48	5240	16.47	17.24	97.327	19.88	27.37	Pass
149	5745	19.40	17.80	147.352	21.68	27.37	Pass
157	5785	19.60	18.43	160.864	22.06	27.37	Pass
165	5825	17.12	17.44	106.986	20.29	27.37	Pass

Note: Max. Beamforming Gain = $5.62\text{dBi} + 10\log(2) = 8.63\text{dBi} > 6\text{dBi}$, so the limit shall be reduced to $30 - (8.63 - 6) = 27.37\text{dBm}$.

802.11n (HT40)

Chan.	Freq. (MHz)	Maximum Conducted Power (dBm)		Total Power (mW)	Total Power (dBm)	Power Limit (dBm)	Pass / Fail
		Chain 0	Chain 1				
38	5190	15.68	15.91	75.977	18.81	27.37	Pass
46	5230	17.02	16.76	97.774	19.90	27.37	Pass
151	5755	18.64	17.12	124.637	20.96	27.37	Pass
159	5795	17.80	16.61	106.070	20.26	27.37	Pass

Note: Max. Beamforming Gain = $5.62\text{dBi} + 10\log(2) = 8.63\text{dBi} > 6\text{dBi}$, so the limit shall be reduced to $30 - (8.63 - 6) = 27.37\text{dBm}$.

802.11ac (VHT80)

Chan.	Freq. (MHz)	Maximum Conducted Power (dBm)		Total Power (mW)	Total Power (dBm)	Power Limit (dBm)	Pass / Fail
		Chain 0	Chain 1				
42	5210	16.24	16.68	88.632	19.48	27.37	Pass
155	5775	17.88	16.66	107.721	20.32	27.37	Pass

Note: Max. Beamforming Gain = $5.62\text{dBi} + 10\log(2) = 8.63\text{dBi} > 6\text{dBi}$, so the limit shall be reduced to $30 - (8.63 - 6) = 27.37\text{dBm}$.

4.4 Occupied Bandwidth Measurement

4.4.1 Test Setup

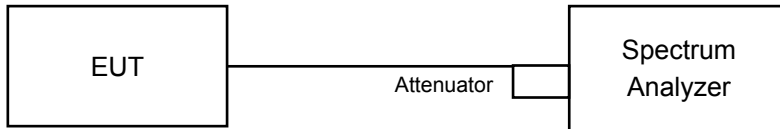

4.4.2 Test Instruments

Refer to section 4.1.2 to get information of above instrument.

4.4.3 Test Procedure

The transmitter output was connected to the spectrum analyzer through an attenuator. The bandwidth of the fundamental frequency was measured by spectrum analyzer with resolution bandwidth in the range of 1% to 5% of the anticipated emission bandwidth, and a video bandwidth at least 3x the resolution bandwidth and set the detector to sampling. The width of a frequency band such that, below the lower and above the upper frequency limits, the mean powers emitted are each equal to a specified percentage 0.5 %of the total mean power of a given emission.

4.4.4 Test Result

802.11a

Channel	Frequency (MHz)	Occupied Bandwidth (MHz)	
		Chain 0	Chain 1
36	5180	16.32	16.56
40	5200	16.20	16.56
48	5240	16.32	16.56
149	5745	16.56	16.32
157	5785	16.44	16.56
165	5825	16.44	16.56

802.11n (HT20)

Channel	Frequency (MHz)	Occupied Bandwidth (MHz)	
		Chain 0	Chain 1
36	5180	17.40	17.76
40	5200	17.28	17.64
48	5240	17.52	17.64
149	5745	17.40	17.40
157	5785	17.52	17.76
165	5825	17.52	17.76

802.11n (HT40)

Channel	Frequency (MHz)	Occupied Bandwidth (MHz)	
		Chain 0	Chain 1
38	5190	36.72	36.12
46	5230	36.36	36.12
151	5755	36.84	36.60
159	5795	36.60	36.12

802.11ac (VHT80)

Channel	Frequency (MHz)	Occupied Bandwidth (MHz)	
		Chain 0	Chain 1
42	5210	76.32	75.84
155	5775	76.56	75.84

Spectrum Plot of Worst Value

802.11a

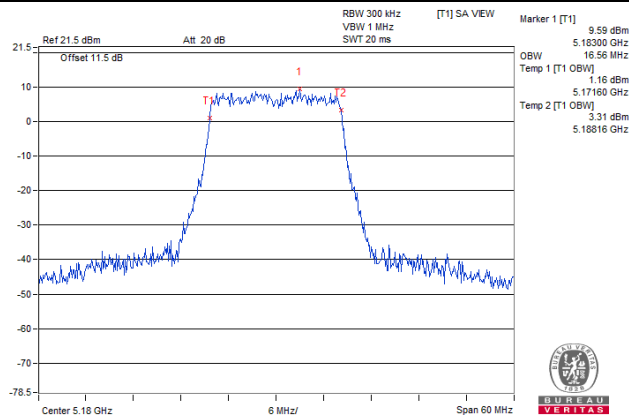

802.11n (HT20)

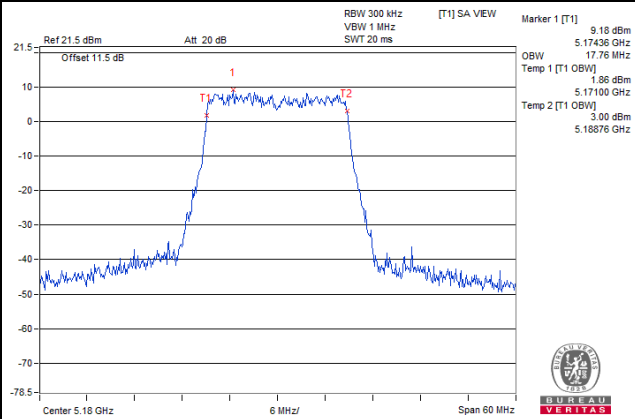

802.11n (HT40)

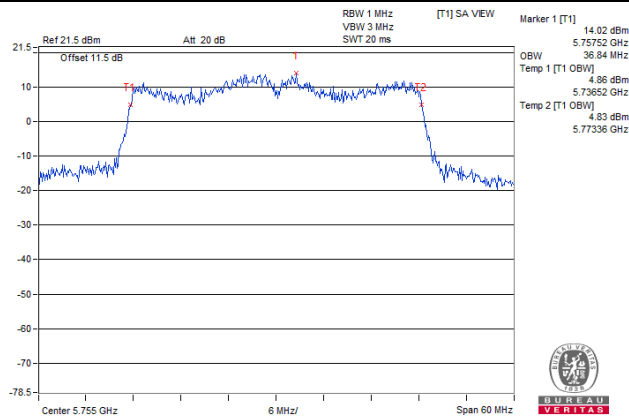

802.11ac (VHT80)

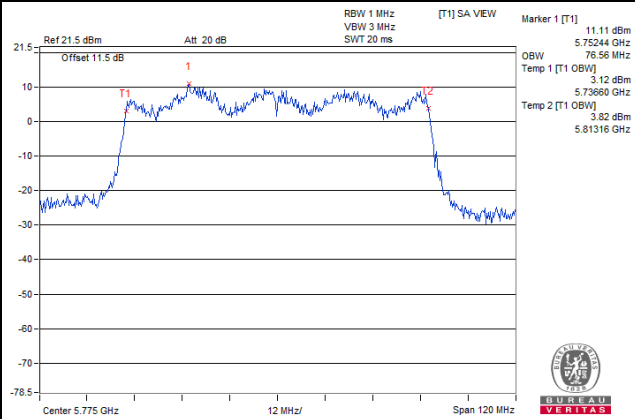

Spectrum Plot of Worst Value

802.11a Ch 48

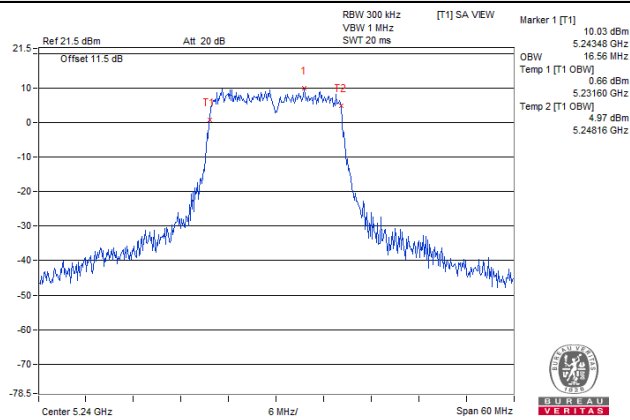

802.11n (HT20) Ch 48

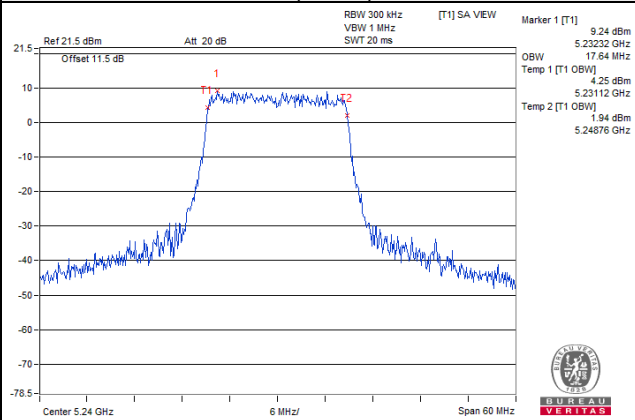

802.11n (HT40) Ch 46

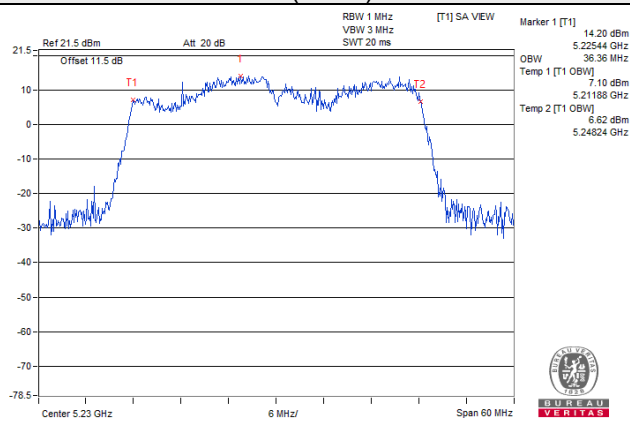

802.11ac (VHT80) Ch 42

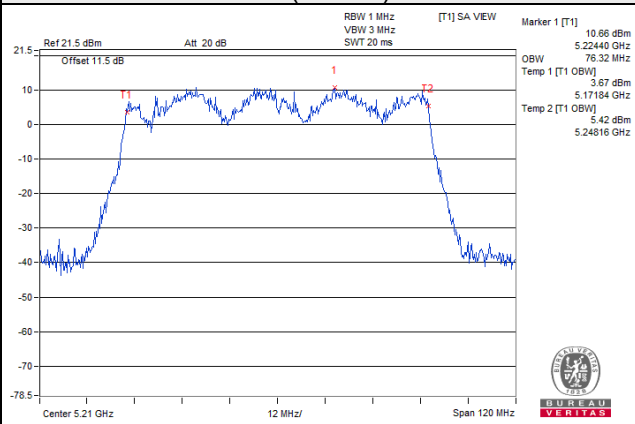

4.5 Peak Power Spectral Density Measurement

4.5.1 Limits of Peak Power Spectral Density Measurement

Operation Band	EUT Category		LIMIT
U-NII-1		Outdoor Access Point	17dBm/ MHz
		Fixed point-to-point Access Point	
	√	Indoor Access Point	
		Mobile and Portable client device	11dBm/ MHz
U-NII-2A	-		11dBm/ MHz
U-NII-2C	-		11dBm/ MHz
U-NII-3	√		30dBm/ 500kHz

4.5.2 Test Setup

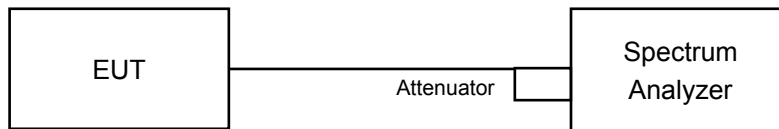

4.5.3 Test Instruments

Refer to section 4.1.2 to get information of above instrument.

4.5.4 Test Procedures

For U-NII-1 band:

Duty cycle of test signal is $\geq 98\%$

Using method SA-1

- 1) Set span to encompass the entire emission bandwidth (EBW) of the signal.
- 2) Set RBW = 1MHz, Set VBW ≥ 3 MHz, Detector = RMS.
- 3) Set Channel power measure = 1MHz.
- 4) Sweep time = auto, trigger set to "free run".
- 5) Trace average at least 100 traces in power averaging mode.
- 6) Record the max value.

Duty cycle of test signal is $< 98\%$

Using method SA-2

- 1) Set span to encompass the entire emission bandwidth (EBW) of the signal.
- 2) Set RBW = 1MHz, Set VBW ≥ 3 MHz, Detector = RMS.
- 3) Set Channel power measure = 1MHz.
- 4) Sweep time = auto, trigger set to "free run".
- 5) Trace average at least 100 traces in power averaging mode.
- 6) Record the max value and add $10 \log (1/\text{duty cycle})$.

For U-NII-3 band:

Duty cycle of test signal is $\geq 98\%$

Using method SA-1

- 1) Set span to encompass the entire emission bandwidth (EBW) of the signal.
- 2) Set RBW = 300 kHz, Set VBW ≥ 1 MHz, Detector = RMS.
- 3) Use the peak marker function to determine the maximum power level in any 300 kHz band segment within the fundamental EBW.
- 4) Scale the observed power level to an equivalent value in 500 kHz by adjusting (reducing) the measured power by a bandwidth correction factor (BWCF) where $BWCF = 10\log(500 \text{ kHz} / 300 \text{ kHz})$.
- 5) Sweep time = auto, trigger set to "free run".
- 6) Trace average at least 100 traces in power averaging mode.
- 7) Record the max value.

Duty cycle of test signal is $< 98\%$

- 1) Set span to encompass the entire emission bandwidth (EBW) of the signal.
- 2) Set RBW = 300 kHz, Set VBW ≥ 1 MHz, Detector = RMS.
- 3) Use the peak marker function to determine the maximum power level in any 300 kHz band segment within the fundamental EBW.
- 4) Scale the observed power level to an equivalent value in 500 kHz by adjusting (reducing) the measured power by a bandwidth correction factor (BWCF) where $BWCF = 10\log(500 \text{ kHz} / 300 \text{ kHz})$.
- 5) Sweep time = auto, trigger set to "free run".
- 6) Trace average at least 100 traces in power averaging mode.
- 7) Record the max value and add $10 \log (1/\text{duty cycle})$.

4.5.5 Deviation from Test Standard

No deviation.

4.5.6 EUT Operating Conditions

Same as 4.3.6.

4.5.7 Test Results

For U-NII-1 band:
802.11a

Chan.	Freq. (MHz)	PSD W/O Duty Factor (dBm/MHz)		Duty Factor (dB)	Total PSD With Duty Factor (dBm/MHz)	Max. Limit (dBm/MHz)	Pass / Fail
		Chain 0	Chain 1				
36	5180	8.64	6.13	0.21	10.78	14.37	Pass
40	5200	8.76	6.57	0.21	11.02	14.37	Pass
48	5240	9.46	7.13	0.21	11.67	14.37	Pass

Note:

- Method E) 2) a) of power density measurement of KDB 662911 is using for calculating total power density. Total power density is summing entire spectra across corresponding frequency bins on the various outputs by computer.
- Max. Directional Gain = $5.62\text{dBi} + 10\log(2) = 8.63\text{dBi} > 6\text{dBi}$, so the limit shall be reduced to $17 - (8.63 - 6) = 14.37\text{dBm}$.
- Refer to section 3.3 for duty cycle spectrum plot.

802.11n (HT20)

Chan.	Freq. (MHz)	PSD W/O Duty Factor (dBm/MHz)		Duty Factor (dB)	Total PSD With Duty Factor (dBm/MHz)	Max. Limit (dBm/MHz)	Pass / Fail
		Chain 0	Chain 1				
36	5180	8.83	5.87	0.11	10.72	14.37	Pass
40	5200	8.59	5.74	0.11	10.51	14.37	Pass
48	5240	9.63	7.00	0.11	11.63	14.37	Pass

Note:

- Method E) 2) a) of power density measurement of KDB 662911 is using for calculating total power density. Total power density is summing entire spectra across corresponding frequency bins on the various outputs by computer.
- Max. Directional Gain = $5.62\text{dBi} + 10\log(2) = 8.63\text{dBi} > 6\text{dBi}$, so the limit shall be reduced to $17 - (8.63 - 6) = 14.37\text{dBm}$.
- Refer to section 3.3 for duty cycle spectrum plot.

802.11n (HT40)

Chan.	Freq. (MHz)	PSD W/O Duty Factor (dBm/MHz)		Duty Factor (dB)	Total PSD With Duty Factor (dBm/MHz)	Max. Limit (dBm/MHz)	Pass / Fail
		Chain 0	Chain 1				
38	5190	5.83	2.74	0.20	7.76	14.37	Pass
46	5230	6.82	4.48	0.20	9.02	14.37	Pass

Note:

- Method E) 2) a) of power density measurement of KDB 662911 is using for calculating total power density. Total power density is summing entire spectra across corresponding frequency bins on the various outputs by computer.
- Max. Directional Gain = $5.62\text{dBi} + 10\log(2) = 8.63\text{dBi} > 6\text{dBi}$, so the limit shall be reduced to $17 - (8.63 - 6) = 14.37\text{dBm}$.
- Refer to section 3.3 for duty cycle spectrum plot.

802.11ac (VHT80)

Chan.	Freq. (MHz)	PSD W/O Duty Factor (dBm/MHz)		Duty Factor (dB)	Total PSD With Duty Factor (dBm/MHz)	Max. Limit (dBm/MHz)	Pass / Fail
		Chain 0	Chain 1				
42	5210	2.43	0.47	0.30	4.87	14.37	Pass

Note:

- Method E) 2) a) of power density measurement of KDB 662911 is using for calculating total power density. Total power density is summing entire spectra across corresponding frequency bins on the various outputs by computer.
- Max. Directional Gain = 5.62dBi + 10log(2) = 8.63dBi > 6dBi, so the limit shall be reduced to 17-(8.63-6) = 14.37dBm.
- Refer to section 3.3 for duty cycle spectrum plot.

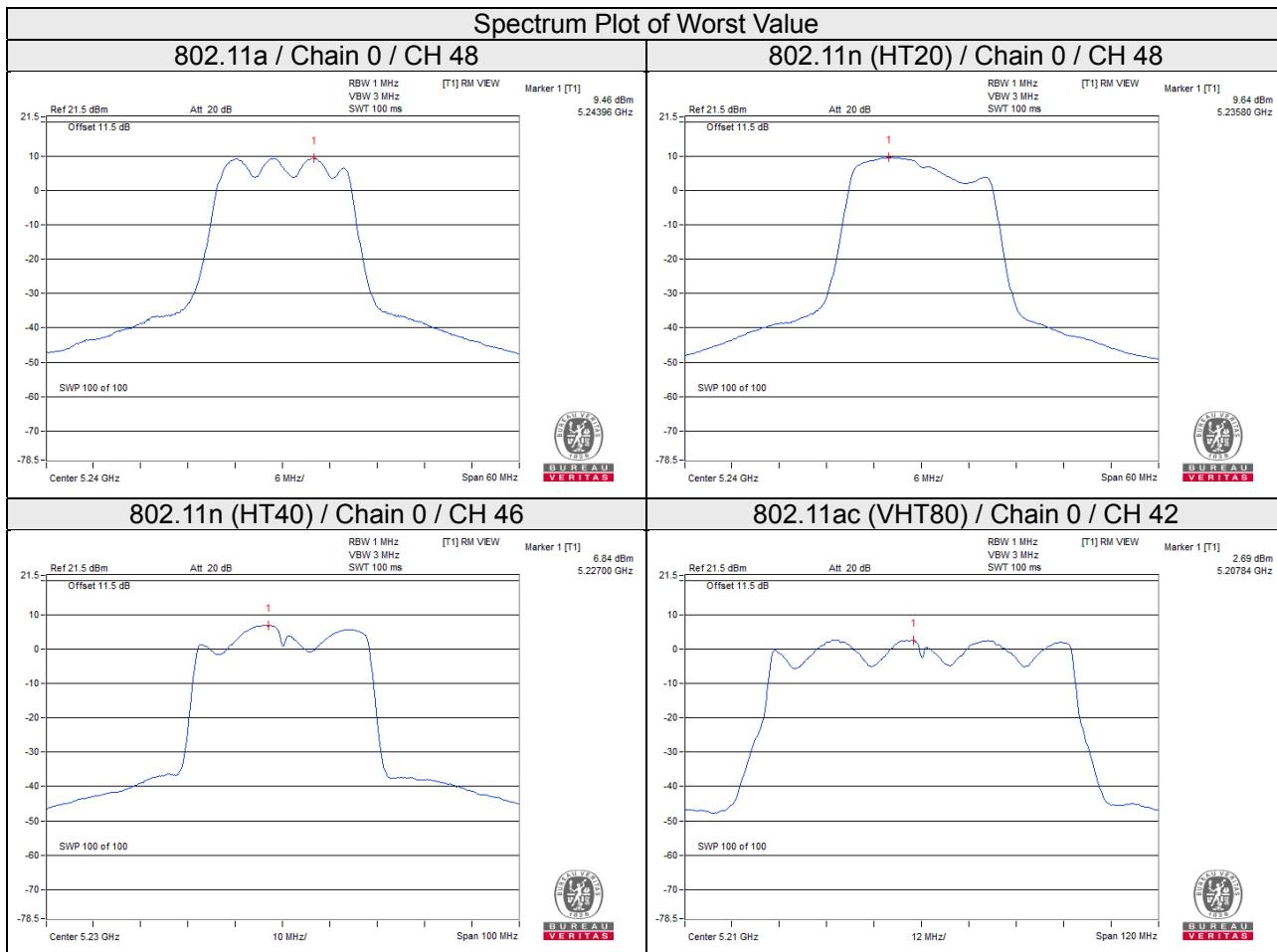

For U-NII-3 band:

802.11a

TX chain	Chan.	Freq. (MHz)	PSD W/O Duty Factor		10 log (N=2) dB	Duty Factor (dB)	Total PSD With Duty Factor (dBm/500kHz)	Limit (dBm/500kHz)	Pass / Fail
			(dBm/300kHz)	(dBm/500kHz)					
0	149	5745	4.48	6.70	3.01	0.21	9.92	27.37	Pass
	157	5785	5.18	7.40	3.01	0.21	10.62	27.37	Pass
	165	5825	3.75	5.97	3.01	0.21	9.19	27.37	Pass
1	149	5745	6.05	8.27	3.01	0.21	11.49	27.37	Pass
	157	5785	6.45	8.67	3.01	0.21	11.89	27.37	Pass
	165	5825	5.03	7.25	3.01	0.21	10.47	27.37	Pass

Note:

1. Method E) 2) c) of power density measurement of KDB 662911 is using for calculating total power density.
2. Max. Directional Gain = $5.62\text{dBi} + 10\log(2) = 8.63\text{dBi} > 6\text{dBi}$, so the limit shall be reduced to $30 - (8.63 - 6) = 27.37\text{dBm}$.
3. Refer to section 3.3 for duty cycle spectrum plot.

802.11n (HT20)

TX chain	Chan.	Freq. (MHz)	PSD W/O Duty Factor		10 log (N=2) dB	Duty Factor (dB)	Total PSD With Duty Factor (dBm/500kHz)	Limit (dBm/500kHz)	Pass / Fail
			(dBm/300kHz)	(dBm/500kHz)					
0	149	5745	4.08	6.30	3.01	0.11	9.42	27.37	Pass
	157	5785	4.75	6.97	3.01	0.11	10.09	27.37	Pass
	165	5825	3.32	5.54	3.01	0.11	8.66	27.37	Pass
1	149	5745	5.59	7.81	3.01	0.11	10.93	27.37	Pass
	157	5785	6.02	8.24	3.01	0.11	11.36	27.37	Pass
	165	5825	4.24	6.46	3.01	0.11	9.58	27.37	Pass

Note:

1. Method E) 2) c) of power density measurement of KDB 662911 is using for calculating total power density.
2. Max. Directional Gain = $5.62\text{dBi} + 10\log(2) = 8.63\text{dBi} > 6\text{dBi}$, so the limit shall be reduced to $30 - (8.63 - 6) = 27.37\text{dBm}$.
3. Refer to section 3.3 for duty cycle spectrum plot.

802.11n (HT40)

TX chain	Chan.	Freq. (MHz)	PSD W/O Duty Factor		10 log (N=2) dB	Duty Factor (dB)	Total PSD With Duty Factor (dBm/500kHz)	Limit (dBm/500kHz)	Pass / Fail
			(dBm/300kHz)	(dBm/500kHz)					
0	151	5755	1.44	3.66	3.01	0.20	6.87	27.37	Pass
	159	5795	0.64	2.86	3.01	0.20	6.07	27.37	Pass
1	151	5755	3.09	5.31	3.01	0.20	8.52	27.37	Pass
	159	5795	2.10	4.32	3.01	0.20	7.53	27.37	Pass

Note:

1. Method E) 2) c) of power density measurement of KDB 662911 is using for calculating total power density.
2. Max. Directional Gain = 5.62dBi + 10log(2) = 8.63dBi > 6dBi, so the limit shall be reduced to 30-(8.63-6) = 27.37dBm.
3. Refer to section 3.3 for duty cycle spectrum plot.

802.11ac (VHT80)

TX chain	Chan.	Freq. (MHz)	PSD W/O Duty Factor		10 log (N=2) dB	Duty Factor (dB)	Total PSD With Duty Factor (dBm/500kHz)	Limit (dBm/500kHz)	Pass / Fail
			(dBm/300kHz)	(dBm/500kHz)					
0	155	5775	-2.54	-0.32	3.01	0.30	2.99	27.37	Pass
1	155	5775	-1.61	0.61	3.01	0.30	3.92	27.37	Pass

Note:

1. Method E) 2) c) of power density measurement of KDB 662911 is using for calculating total power density.
2. Max. Directional Gain = 5.62dBi + 10log(2) = 8.63dBi > 6dBi, so the limit shall be reduced to 30-(8.63-6) = 27.37dBm.
3. Refer to section 3.3 for duty cycle spectrum plot.

Spectrum Plot of Worst Value

802.11a

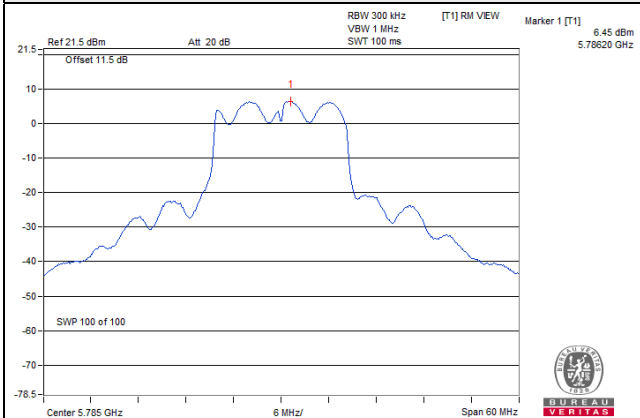

802.11n (HT20)

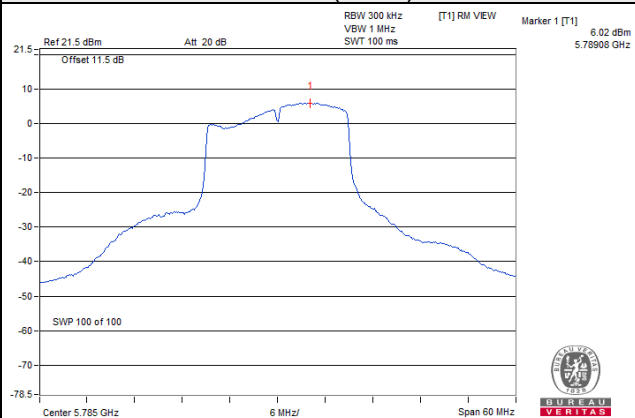

802.11n (HT40)

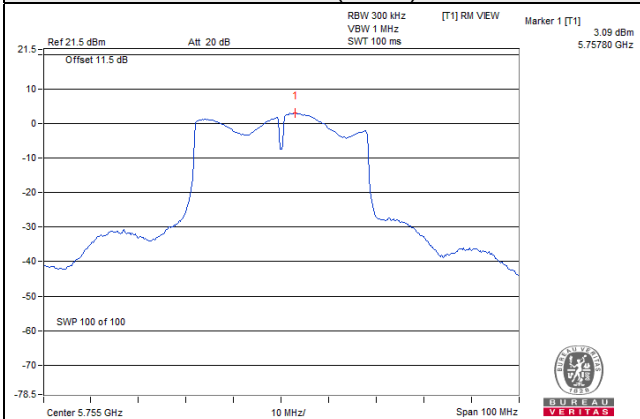

802.11ac (VHT80)

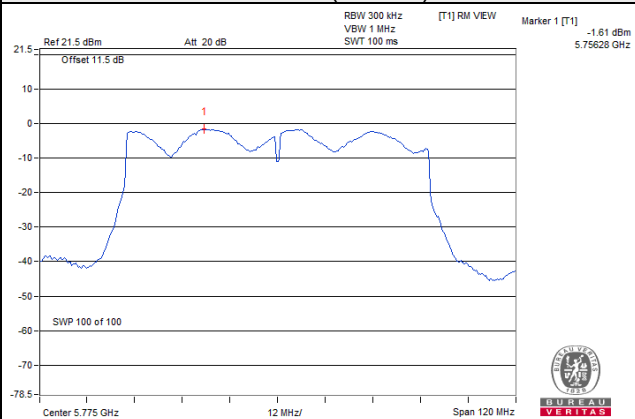

4.6 Frequency Stability

4.6.1 Limits of Frequency Stability Measurement

The frequency of the carrier signal shall be maintained within band of operation

4.6.2 Test Setup

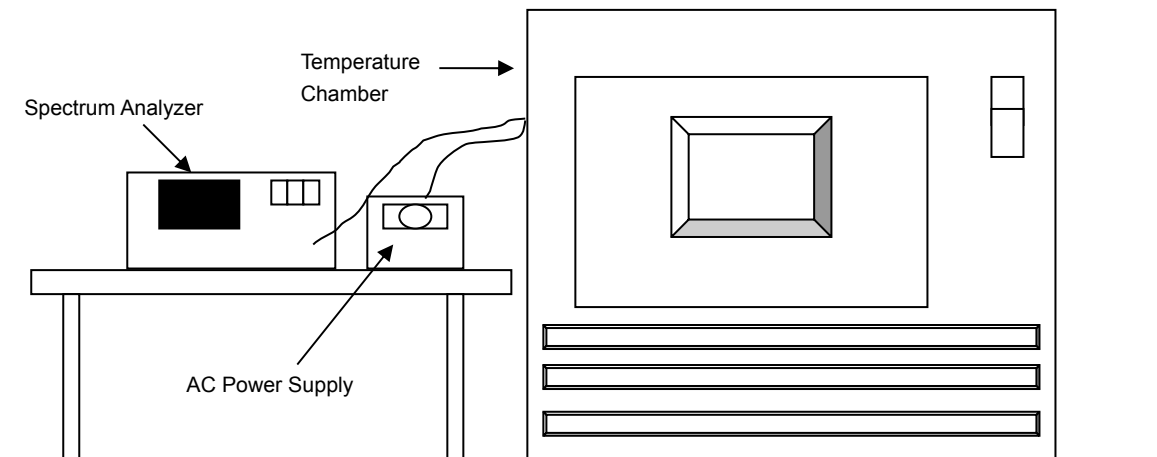

4.6.3 Test Instruments

Description & Manufacturer	Model No.	Serial No.	Cal. Date	Cal. Due
Spectrum Analyzer ROHDE & SCHWARZ	FSP40	100040	Sep. 25, 2018	Sep. 24, 2019
WIT Standard Temperature And Humidity Chamber	TH-4S-C	W981030	Jun. 03, 2019	Jun. 02, 2020
Digital Multimeter Fluke	87-III	70360742	Jun. 27, 2019	Jun. 26, 2020
AC Power Supply Extech	CFW-105	E000603	NA	NA
True RMS Clamp Meter / Fluke	325	31130711WS	May 21, 2019	May 20, 2020

4.6.4 Test Procedure

- The EUT was placed inside the environmental test chamber and powered by nominal AC voltage.
- Turn the EUT on and couple its output to a spectrum analyzer.
- Turn the EUT off and set the chamber to the highest temperature specified.
- Allow sufficient time (approximately 30 min) for the temperature of the chamber to stabilize, turn the EUT on and measure the operating frequency after 2, 5, and 10 minutes.
- Repeat step d. with the temperature chamber set to the next desired temperature until measurements down to the lowest specified temperature have been completed.
- The test chamber was allowed to stabilize at +20 degree C for a minimum of 30 minutes. The supply voltage was then adjusted on the EUT from 85% to 115% and the frequency record.

4.6.5 Deviation from Test Standard

No deviation.

4.6.6 EUT Operating Condition

Set the EUT transmit at un-modulation mode to test frequency stability.

4.6.7 Test Results

Frequency Stability Versus Temp.									
Operating Frequency: 5180MHz									
Temp. (°C)	Power Supply (Vac)	0 Minute		2 Minute		5 Minute		10 Minute	
		Measured Frequency (MHz)	Pass/Fail	Measured Frequency (MHz)	Pass/Fail	Measured Frequency (MHz)	Pass/Fail	Measured Frequency (MHz)	Pass/Fail
50	120	5179.9729	PASS	5179.9771	PASS	5179.9752	PASS	5179.9777	PASS
40	120	5179.9863	PASS	5179.985	PASS	5179.9865	PASS	5179.9889	PASS
30	120	5180.0067	PASS	5180.0054	PASS	5180.0069	PASS	5180.0054	PASS
20	120	5180.0173	PASS	5180.0195	PASS	5180.0165	PASS	5180.0168	PASS
10	120	5180.0165	PASS	5180.0168	PASS	5180.0193	PASS	5180.0154	PASS
0	120	5179.9734	PASS	5179.9727	PASS	5179.9743	PASS	5179.9754	PASS

Frequency Stability Versus Voltage									
Operating Frequency: 5180MHz									
Temp. (°C)	Power Supply (Vac)	0 Minute		2 Minute		5 Minute		10 Minute	
		Measured Frequency (MHz)	Pass/Fail	Measured Frequency (MHz)	Pass/Fail	Measured Frequency (MHz)	Pass/Fail	Measured Frequency (MHz)	Pass/Fail
20	138	5180.0178	PASS	5180.0187	PASS	5180.0156	PASS	5180.0167	PASS
	120	5180.0173	PASS	5180.0195	PASS	5180.0165	PASS	5180.0168	PASS
	102	5180.0164	PASS	5180.0202	PASS	5180.0169	PASS	5180.0162	PASS

4.7 6dB Bandwidth Measurement

4.7.1 Limits of 6dB Bandwidth Measurement

The minimum of 6dB Bandwidth Measurement is 0.5MHz.

4.7.2 Test Setup

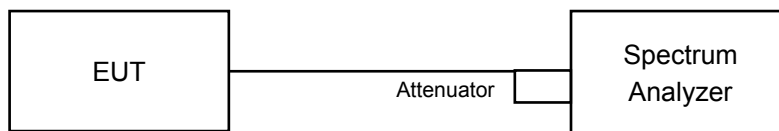

4.7.3 Test Instruments

Refer to section 4.1.2 to get information of above instrument.

4.7.4 Test Procedure

Measurement Procedure REF

- Set resolution bandwidth (RBW) = 100kHz
- Set the video bandwidth (VBW) $\geq 3 \times$ RBW, Detector = Peak.
- Trace mode = max hold.
- Sweep = auto couple.
- Measure the maximum width of the emission that is constrained by the frequencies associated with the two amplitude points (upper and lower) that are attenuated by 6 dB relative to the maximum level measured in the fundamental emission

4.7.5 Deviation from Test Standard

No deviation.

4.7.6 EUT Operating Condition

The software provided by client to enable the EUT under transmission condition continuously at lowest, middle and highest channel frequencies individually.

4.7.7 Test Results

802.11a

Chan.	Freq. (MHz)	6dB Bandwidth (MHz)		Minimum Limit (MHz)	Pass / Fail
		Chain 0	Chain 1		
149	5745	13.25	13.86	0.5	Pass
157	5785	14.46	15.76	0.5	Pass
165	5825	15.72	16.16	0.5	Pass

802.11n (HT20)

Chan.	Freq. (MHz)	6dB Bandwidth (MHz)		Minimum Limit (MHz)	Pass / Fail
		Chain 0	Chain 1		
149	5745	12.66	13.89	0.5	Pass
157	5785	14.42	16.62	0.5	Pass
165	5825	15.11	16.99	0.5	Pass

802.11n (HT40)

Chan.	Freq. (MHz)	6dB Bandwidth (MHz)		Minimum Limit (MHz)	Pass / Fail
		Chain 0	Chain 1		
151	5755	35.15	35.50	0.5	Pass
159	5795	33.89	35.38	0.5	Pass

802.11ac (VHT80)

Chan.	Freq. (MHz)	6dB Bandwidth (MHz)		Minimum Limit (MHz)	Pass / Fail
		Chain 0	Chain 1		
155	5775	74.18	75.90	0.5	Pass

Spectrum Plot of Worst Value

802.11a

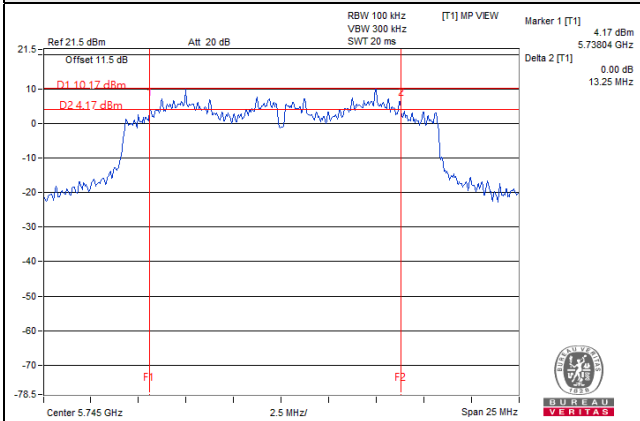

802.11n (HT20)

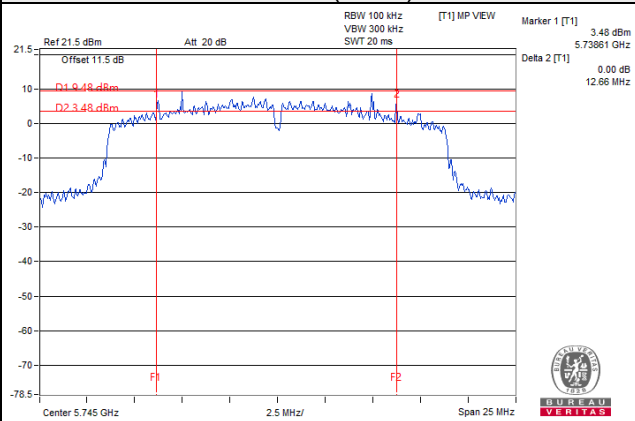

802.11n (HT40)

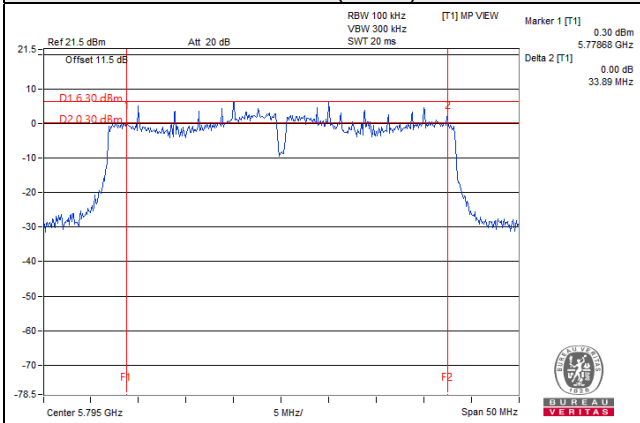

802.11ac (VHT80)

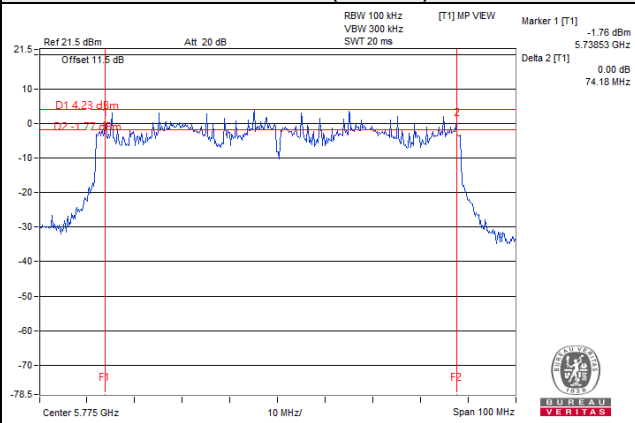

5 Pictures of Test Arrangements

Please refer to the attached file (Test Setup Photo).

Annex A- Radiated Out of Band Emission (OOBE) Measurement (For U-NII-3 band)

802.11a

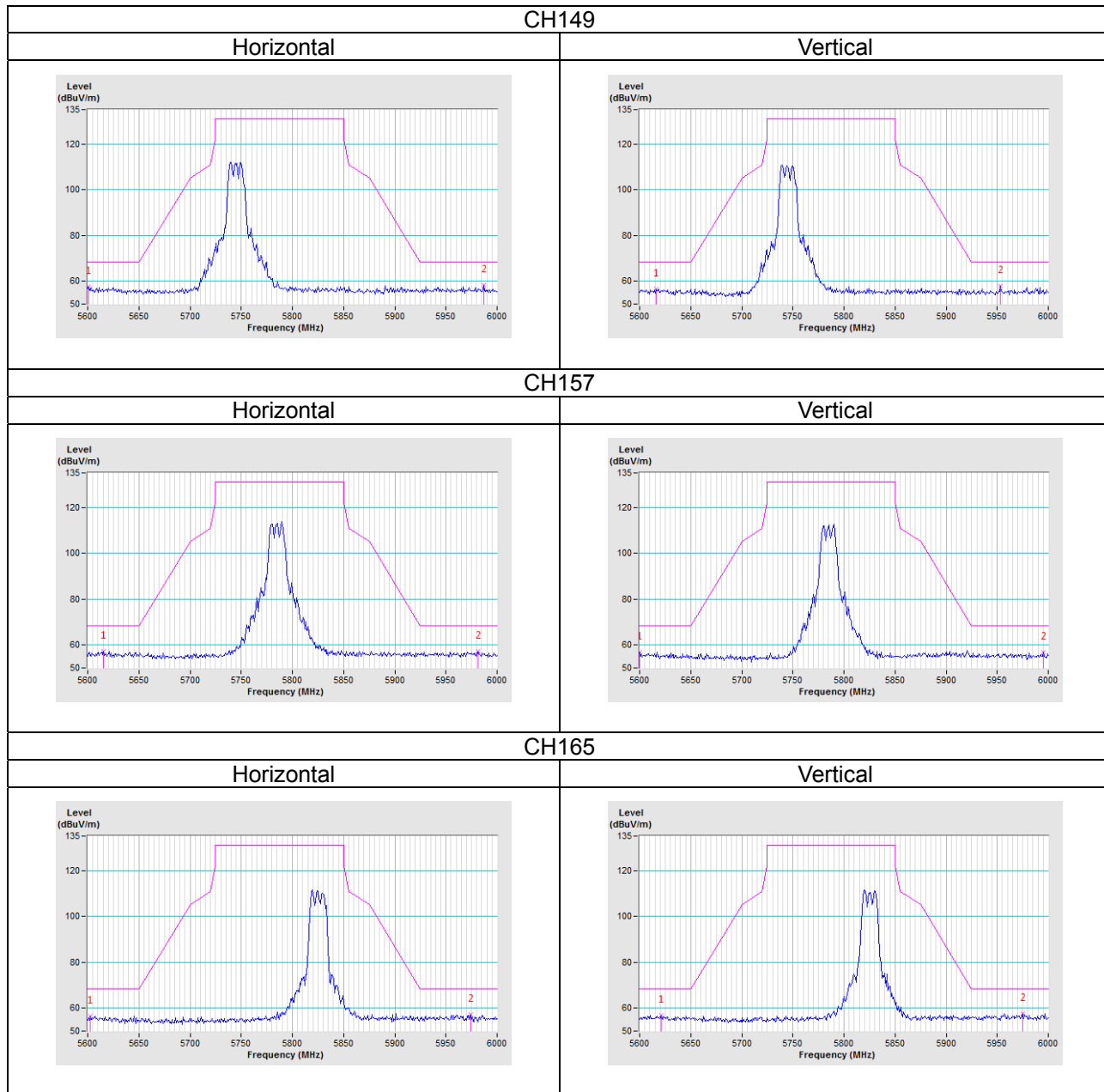

802.11n (HT20)

CH149

Horizontal

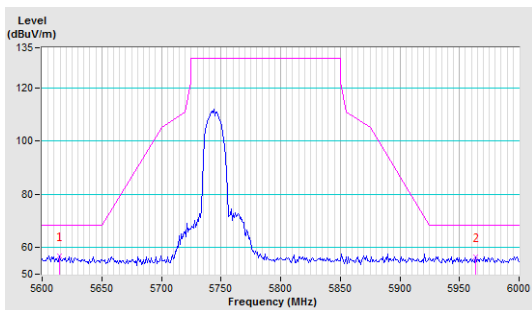

Vertical

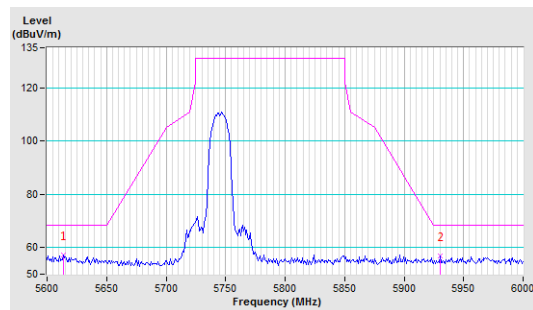

CH157

Horizontal

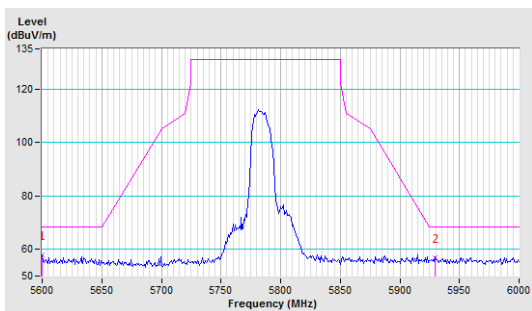

Vertical

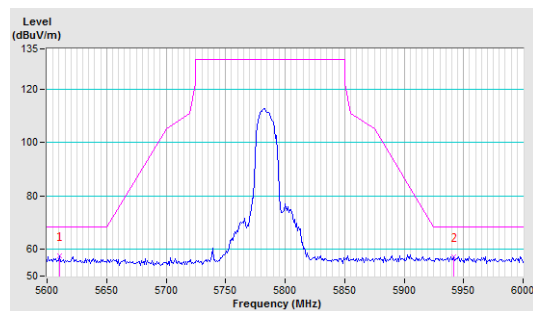

CH165

Horizontal

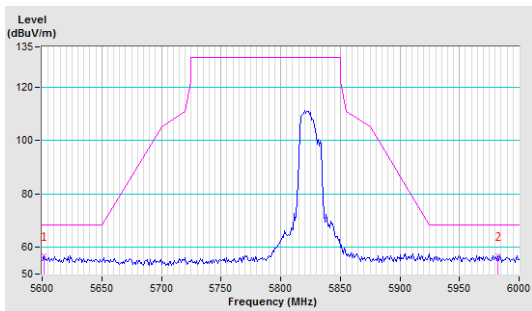

Vertical

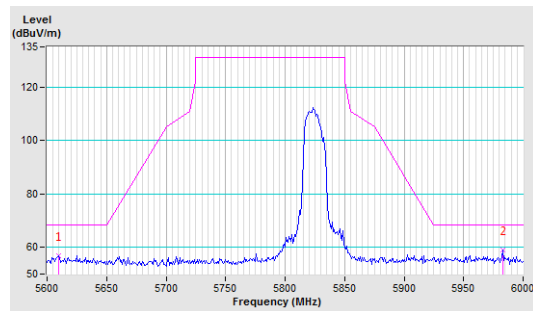

802.11n (HT40)

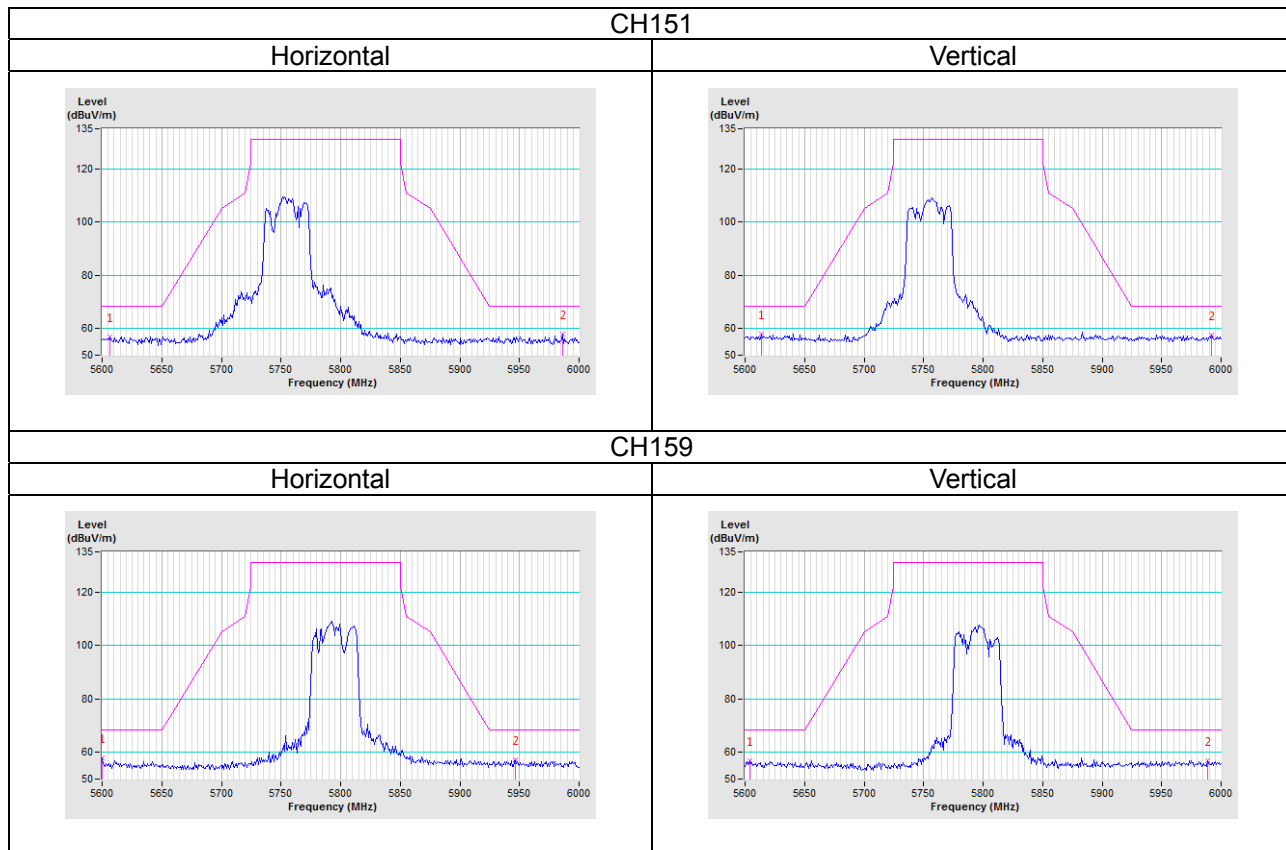

802.11ac (VHT80)

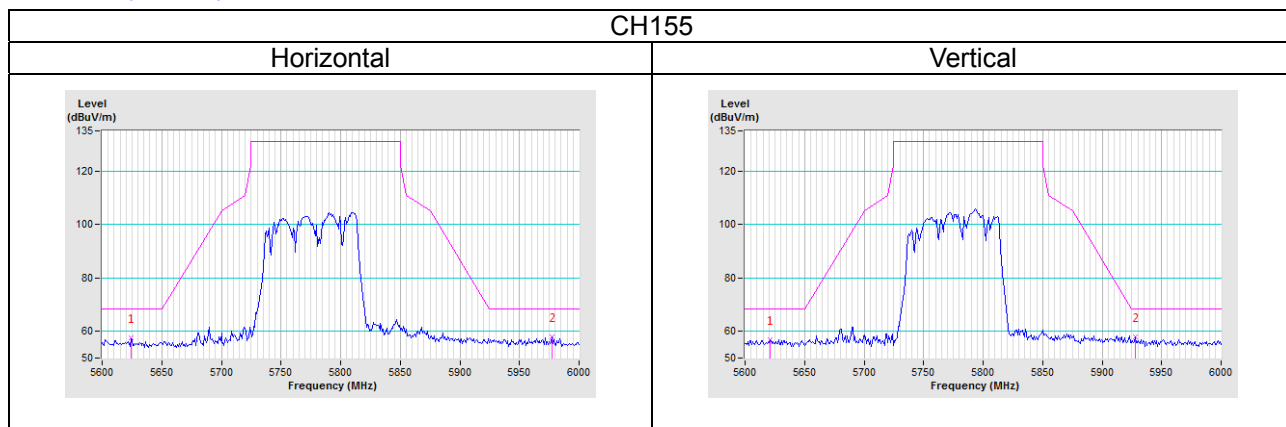

Appendix – Information of the Testing Laboratories

We, Bureau Veritas Consumer Products Services (H.K.) Ltd., Taoyuan Branch, were founded in 1988 to provide our best service in EMC, Radio, Telecom and Safety consultation. Our laboratories are FCC recognized accredited test firms and accredited and approved according to ISO/IEC 17025.

If you have any comments, please feel free to contact us at the following:

Linko EMC/RF Lab

Tel: 886-2-26052180

Fax: 886-2-26051924

Hsin Chu EMC/RF/Telecom Lab

Tel: 886-3-6668565

Fax: 886-3-6668323

Hwa Ya EMC/RF/Safety Lab

Tel: 886-3-3183232

Fax: 886-3-3270892

Email: service.adt@tw.bureauveritas.com

Web Site: www.bureauveritas-adt.com

The address and road map of all our labs can be found in our web site also.

--- END ---