



Model: E820

POS Payment Terminal



User Guide

Fujian LANDI
Commercial Equipment Co.,Ltd

This document is the property of LANDI.

Its content cannot be reproduced or divulged without the company's written approval.

Contents

1. Introduction	3
2. Unpacking	3
3. Appearance of E820	3
3.1 Keypad function	5
4. Use of the terminal	6
4.1 Power on/Power off the terminal	6
4.2 Reading cards	7
4.3 Installing Modules.....	7
4.4 Battery	9
4.5 Paper roll.....	10
4.6 Base Installation	10
5. Recommendations	11
5.1 Safety	11
5.2 Security of your terminal	12
5.3 Cleaning of the terminal	13
5.4 Transport and storage	13
6. Standard	13
7. Troubleshooting	15

1. Introduction

Thank you for choosing a Landi payment terminal.

We recommend you to read carefully this user guide: It gives you the necessary information about safety precautions, unpacking, installation, and maintenance of your terminal.

WARRANTY/SECURITY



To benefit from the guarantee-related product, and to respect the security, we ask you to use only the power supply delivered in box with the product, entrusting maintenance operations only to an authorized person.

Failure to comply with these instructions will avoid the manufacturer's responsibility.

2. Unpacking



ADVICE

Carefully preserve the packaging of the E820. It must be re-used whenever the terminal is shipped.

According to the model, the following items are included in the E820 box (including optional accessories):

- The E820 terminal
- The main power supply with its cord (according to the national needs)
- A battery pack disconnected
- This user guide

CAUTION



The power supply unit provided with your equipment is specially designed for Landi E820 terminals. Do not use any other power supply. The use of a power supply with apparently similar voltage/current characteristics may damage your terminal.

3. Appearance of E820



-
- ①Top cover, ②LCD display, ③LED display, ④Keypad
⑤IC card slot, ⑥Back cover, ⑦ Magnetic card swiping slot



- ①Paper block board, ②Paper entry, ③Paper exit, ④Manual paper feed knob
⑤Power indication lights, ⑥Base infrared communication port, ⑦ power key,
⑧Automatic aligning paper button



- ①Base infrared communication port, ②SAM1 card socket, ③SAM2 card socket
④MicroSD card socket, ⑤USB port, ⑥Battery cover



①COM1 port, ②COM2 port, ③Power supply socket, ④Ethernet Link RJ45 Port
⑤USB port, ⑥Extension telephone connection, ⑦ Telephone connection,

Power Supply	Base: <ul style="list-style-type: none"> ● Input: AC 110V~240V 50~60Hz/1.2A ● Output: 24VDC, 1.8A Handset: <ul style="list-style-type: none"> ● Input: AC 110V~240V 50~60Hz/0.2A Output: 5VDC, 1.0A
--------------	---

Weight	Handset:265g(with the battery) Base: 559g
Dimension (L x W x H)	Handset: 145.5mm x 80.6mm x 35.5mm Base: 293.6mm × 129.3mm × 84.5mm
Electrical mains network	110-240VAC/50-60Hz

Operating conditions

Ambient temperature	0°C ~ 40°C
Max relative humidity	5% ~ 90%, Non-condensing

Storage conditions

Storage temperature	-20°C ~ 70°C
Max relative humidity	5% ~ 90%, Non-condensing

3.1 Keypad function

The Reserved function Keys/Navigation Keys can have other functions according to the application that are in the terminal.



Menu Key: to be used alone or with other keys, depending on customer needs.

Power Key: to switch power or screen display. Details refer to "Switch Operation" instruction.

Cancel Key (Red): to cancel the current operation or return to the parent menu.

Clear Key (Yellow): to delete the latest input.

Enter Key (Green): to confirm current operation and information

0~9 Keys: to input number from 0 to 9.

ALPHA: to switch alphanumeric

Character (* #.): to switch character

4. Use of the terminal

4.1 Power on/Power off the terminal

To power on: Press <Power> button for about 1s until the display shows the Landi logo.

To power off: Press <Power> button for more than 2s until the display show the following figure, select <Shutdown> using navigation keys, then press validation key (green).

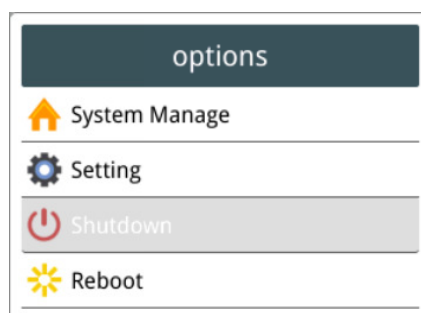

If the battery is empty, the terminal automatically shuts off.

Abnormal power off:

When the device works abnormally, for example, it is crashed and no actions menu

popped out while pressing the power button, please long-press the power button for 6s, the device will be automatically powered off.

Screen switch operation:

Short-press the power button for about 0.5s, the terminal display will be turned on or off.

4.2 Reading cards

Magnetic stripe card

The card can be read bi-directionally, with the stripe facing the terminal. Use a regular movement in order to ensure a reliable card reading.



Smart card

Insert the card horizontally with the metal chip facing upward and leave in position throughout the transaction.

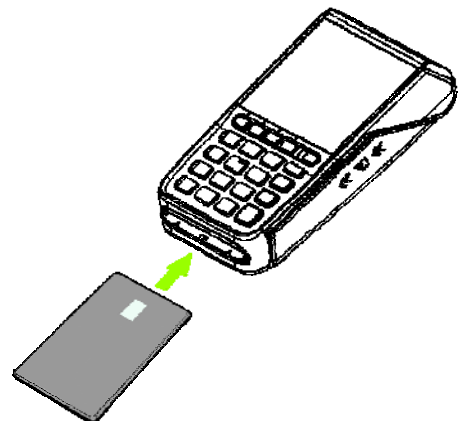

Contactless card (optional)

Bring the card firmly up to the active zone. Keep the card close to the reader during the transaction.

On the screen virtual LEDs are displayed to indicate transaction processing.

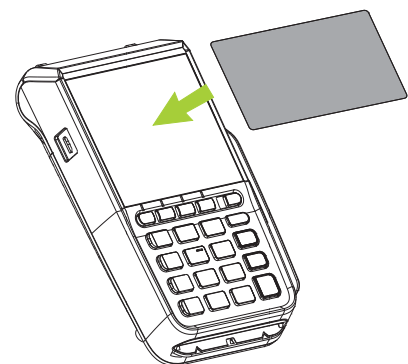

4.3 Installing Modules

4.3.1 SAM1/SAM2/SIM



CAUTION:

Switch off the terminal before opening the trapdoor.

The SAM/SIM connectors are located inside the terminal, in a closed compartment.

- Turn the terminal and remove the trapdoor after using screwdriver to unscrew the screw.

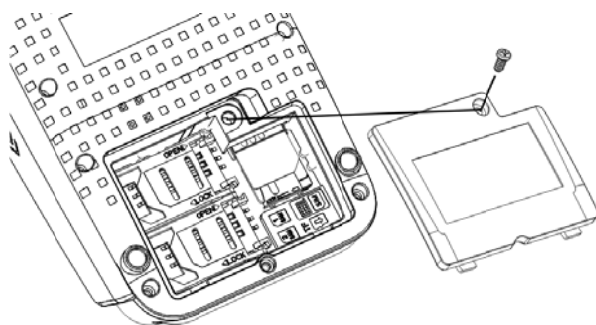

- SAM1, SAM2 and SIM are identified by the engraved marks on the lower housing.
- Remove battery pack (disconnecting is not necessary) .
- Install the SAM/SIM card into the connector slot as show on the figure.
- When introducing a SAM/SIM in its slot, be sure to put the cut corner as indicated on the picture.
- Close the trapdoor and tighten the screw.

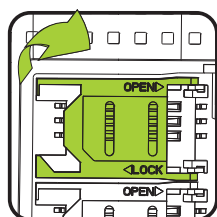

(SAM card)

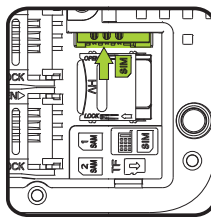

(SIM card)



NOTICE

The appearance of the sockets of SIM card and SAM is same. Please do pay attention to the SIM card socket position. Only certain configurable products containing SIM card, please consult the customer Manager.

4.3.2 MicroSD Memory Card

**CAUTION:**

Switch off the terminal before opening the trapdoor.

MicroSD connector is located inside the terminal, in a closed compartment.

- Turn the terminal and remove the trapdoor after using screwdriver to unscrew the screw.
- MicroSD are identified by the engraved marks on the lower housing.
- Remove battery pack (disconnecting is not necessary).
- Push the cover backwards and open it. Insert MicroSD card and then close the cover and pull forwards. Be sure to put the MicroSD contacts downside and the cut corner as indicated on the figure.
- Close the trapdoor and screw it.

The terminal supports MicroSD up to 32GB.

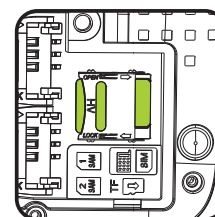
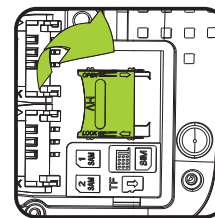

4.4 Battery

4.4.1 Installing the battery

**CAUTION:**

Check that the terminal is not connected to the main electric network.

- Turn your terminal and unclip the battery trapdoor by pushing the clips as shown with the arrow on the picture.
- Take the battery pack included in the box.
- Locate the battery pack connector beside the battery compartment.
- Plug the battery pack connector according to the connector locating system.
- Place the battery pack in its compartment.
- Close the battery trapdoor.

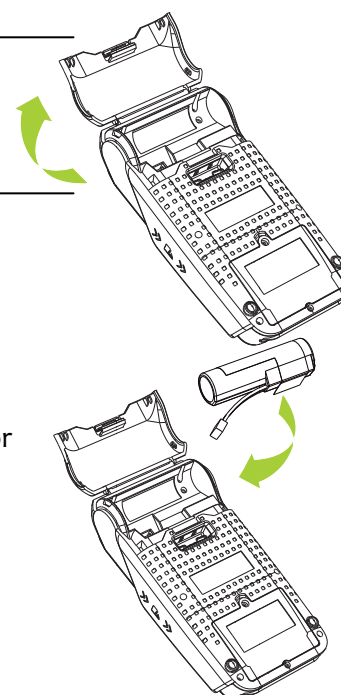

4.4.2 Charging the battery

- When does the battery need to be charged?
 - When used daily, the terminal recharges its battery each time the power adapter is connected. Charging is automatic.

➤ How can the battery be charged?

Using the power adapter

- Connect the power adapter to the terminal micro USB type A connector located on the left side of the terminal.
- Connect the power adapter to the power supply mains network.
- Check if the Red LED under the display is lighted. (It means battery charging)



4.5 Paper roll

4.5.1 Installing paper roll

- Put the print paper into the paper bucket and keep the top of the print paper in the paper entry.
- Rotate a paper knob with counter clockwise to put in paper.
- Press automatic aligning paper button to make the head of the print paper flush with the paper exit.

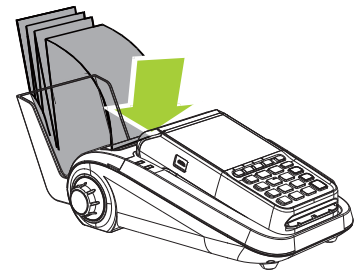

4.5.2 Automatic aligning paper button instructions

Insert the paper head into paper entry, rotate the manual paper feed knob counter-clockwise for a short distance, then press the AUTO key for about 1s, terminal will automatically level the paper head and exit.

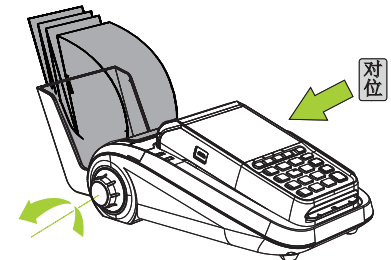

4.6 Base Installation

Please connect the socket as shown with the arrow on the picture.

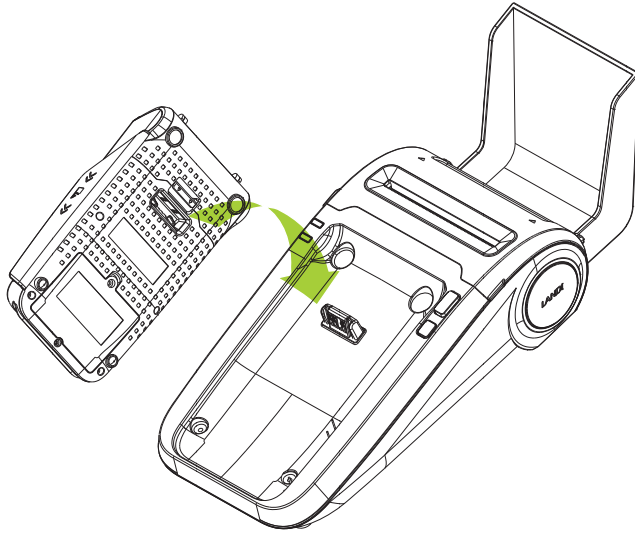

5. Recommendations

5.1 Safety

Lithium cell battery

The E820 is fitted with lithium cell which is not accessible to the user. Only a qualified technician may be authorized to open the unit and change this component.

Lithium-ion battery

E820 is fitted with battery specially designed for this terminal.

- Improper operation of battery may lead to explosion and fire. Contact the qualified service person to change the battery if in need.
- Do not disassemble or modify the battery.
- Do not put the battery into a liquid or exposed to rain or snow.
- Do not short-circuit the battery
- Do not beat and drop
- Keep the battery far away from the fire
- Keep the battery out of the reach of children
- Batteries must be disposed of at appropriate collection points.

The lifespan of battery depends on:

- Features
- Cycle number of charge and discharge
- Use temperature

Electrical power supply network

Provide an electrical outlet:

- Located near the equipment and easily accessible
- Which meets the standards and regulations in the country of use.

SAM1/SAM2/SIM Readers compartment

The trapdoor for battery, SAM1/SAM2/SIM, readers located underneath the terminal, must be in place during the normal operation of the terminal.

On airplanes

Your terminal must be switched off by removing the battery pack. Remove the battery from the terminal when on an airplane.

Non-compliance with these safety rules may result in legal action and/or a ban on later access to cellular network services.

Explosion areas

Some regulations restrict the use of radio equipment in chemical plants, fuel depots and any site where blasting is carried out. You are urged to comply with these regulations. The terminal shall be protected by a specially fitted and certified cover enabling use in proximity to a fuel pump.

Thunderstorm weather

According to some relevant reports, the mobile phone electromagnetic wave is good conductor of lightning. It is much easier to suffer lightning strike when the damp atmosphere form a magnetic conductivity, especially in open areas. Do not use wireless terminals under thunderstorm weather.

Electronic health appliances

Your terminal is a radio transmitter which may interfere with health appliances, such as hearing aids, pacemaker, hospital equipment, etc.

Your doctor or the equipment manufacturer will be able to provide you with appropriate advice.

5.2 Security of your terminal

Upon receipt of your terminal you should check for signs of tampering of the equipment. It is strongly advised that these checks are performed regularly after receipt. You should check, for example: that the keypad is firmly in place; that there is no evidence of unusual wires that have been connected to any ports on your terminal or associated equipment, the chip card reader, or any other part of your terminal. Such checks would provide warning of any unauthorized modifications to your terminal, and other suspicious behavior of individuals that have access to your terminal. Your terminal detects any “tampered state”. In this state the terminal will repeatedly flash the message “Warning Detected” and further use of the terminal will not be possible. If you observe the “Warning Detected” message, you should contact the terminal helpdesk immediately. You are strongly advised to ensure that privileged access to your terminal is only granted to staff that have been independently verified as being trustworthy.



CAUTION

Never ask the customer to divulge their PIN Code. Customers should be advised to ensure that they are not being overlooked when entering their PIN Code.

The terminal must never be put in or left at a location where it could be stolen or replaced with another device.

5.3 Cleaning of the terminal

First of all, unplug all the wires from terminal.

Good rules for proper cleaning of the terminal are:

- Use a soft cloth that is very slightly soaked with soapy water to clean the outside of terminal.
- Do not clean the electrical connections.
- Do not use in any case, solvents, detergents or abrasive products: Those materials might damage the plastic or electrical contacts.
- Avoid exposing the terminal to the direct rays of the sun.
- Do not put anything into the slot of the smart card reader.

5.4 Transport and storage

Adopt general transportation mode, and prevent the goods from sunlight, snow, shower and mechanical impact. Transport the devices with care, do not throw it forcibly. Prevent the packaging from extrusion during transportation, to avoid breakage.

The product should be stored in the original packing box. The warehouse is not allowed to have all sorts of harmful gases, inflammable, explosive, corrosive chemical goods, strong mechanical vibration and strong magnetic field. Packing box should be at least 15cm above the ground, and be away from heat, cold, window or air inlet source at least 50cm.

6. Standard

CE Marking

The CE marking indicates E820 complies with the requirements of European Directive 1995/5/EC of 9 March 1990 on Radio and Telecommunications Terminal Equipment for:

- The protection of the health and the safety of the user and any other person.
- The protection requirements with respect to electromagnetic compatibility.

And complies with harmonised standards.

E820 involved standards are:

- EN60950-1
- EN301 489
- EN301 511
- EN300 328
- EN 300 330
- EN50566

FCC Statement

FCC standard compliance marking certifies that the product stipulated below:

E820

- conforms to the following harmonized standards :
 - part 15 subpart B of the FCC rules

Information to users:

Any Changes or modifications not expressly approved by the party responsible for compliance could void the user's authority to operate the equipment.

NOTE: This equipment has been tested and found to comply with the limits for a Class B digital device, pursuant to part 15 of the FCC Rules. These limits are designed to provide reasonable protection against harmful interference in a residential installation. This equipment generates uses and can radiate radio frequency energy and, if not installed and used in accordance with the instruction, may cause harmful interference to radio communications. However, there is no guarantee that interference will not occur in a particular installation. If this equipment does cause harmful interference to radio or television reception which can be determined by turning the equipment off and on, the user is encouraged to try to correct interference by one or more of the following measures:

- Reorient or relocate the receiving antenna.
- Increase the separation between the equipment and receiver.
- Connect the equipment into an outlet on circuit different from that to which the receiver is connected.
- Consult the dealer or an experienced radio/TV technician for help.

This device complies with FCC exposure limits set forth for an uncontrolled environment. This transmitter must not be co-located or operating in conjunction with any other antenna or transmitter.

Non-compliance with the above restrictions may result in violation of RF exposure guidelines.

This device complies with Part 15 of the FCC Rules. Operation is subject to the following two conditions: (1) this device may not cause harmful interference, and (2) this device must accept any interference received, including interference that may cause undesired operation.

Environment (WEEE, Batteries and packaging)

This product is labeled in accordance with European Directives 2002/96/EC concerning Waste Electrical and Electronic Equipment (WEEE) and 2006/66/EC concerning Batteries and Accumulators. Those provisions are requiring producers and manufacturers to become liable for take-back, treatment and recycling upon end of life of equipment and batteries.



BATTERIES

If your product contains batteries, they must be disposed of at appropriate collection points.

THE PRODUCT

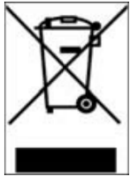

The crossed-out waste bin stuck on the product or its accessories means that the product belongs to the family of electrical and electronic equipment, and waste batteries must not be thrown away but collected separately and recycled.

Please contact your retailers for more detailed information about the compliance solution in place for disposing of your old product and used batteries.

Packaging waste must also be collected separately to assure a proper disposal and recycling.

In this way you can participate in the re-use and upgrading of Electrical and Electronic Equipment Waste, which can have an effect on the environment and human health.

7. Troubleshooting

Q: The terminal cannot be started.

A: The device might be under low energy status or the program may be damaged.

Please make sure the power is enough and then restart your device. If it still fails, please contact our customer service department for help.

Q: The battery cannot be charged.

A: Please use only the power supply provided by Landi. Using wrong type of power supply will probably damage the battery or lead to malfunction. Make sure the power cable, specified power are well connected with terminal.

If the terminal still cannot work, the battery may be end of life or damaged. Please contact our customer service center.

Q: Transaction Processing Failure

A: Following reasons are likely to cause transaction failure: damaged magnetic card or smart card SAM card, damaged card reader, improper operation of card swiping, damaged or unconnected, unconnected phone line, etc.

- Try to use more than one magnetic card to test the transaction, to confirm the failure is not caused by magnetic card.
- Make sure card swiping is operated correctly.
- Manually process the transaction instead of card reader. If manual transaction works, the failure may be caused by magnetic card reader.
- Use more than one smart card to test the transaction, to confirm the failure is not caused by smart card. Make sure the SAM card is correctly inserted into the card slot.

-
- Check if the SIM card is installed correctly and local wireless communication network functions or nor.

If there is still problem, please contact our customer service center.

This Document is Copyright © 2015 by Fujian LANDI Commercial Equipment Co., Ltd. Fujian LANDI retains full copyright ownership, rights and protection in all material contained in this document. The recipient can receive this document on the condition that he will keep the document confidential and will not use its contents in any form or by any means, except as agreed beforehand, without the prior written permission of Fujian LANDI. Moreover, nobody is authorized to place this document at the disposal of any third party without the prior written permission of Fujian LANDI. If such permission is granted, it will be subject to the condition that the recipient ensures that any other recipient of this document, or information contained therein, is held responsible to Fujian LANDI for the confidentiality of that information.

Care has been taken to ensure that the content of this document is as accurate as possible. Fujian Landi however declines any responsibility for inaccurate, incomplete or outdated information. The contents of this document may change from time to time without prior notice, and do not create, specify, modify or replace any new or prior contractual obligations agreed upon in writing between Fujian LANDI and the user.

Fujian LANDI is not responsible for any use of this device, which would be non-consistent with the present document.

All trademarks used in this document remain the property of their rightful owners.

Fujian LANDI Commercial Equipment Co., Ltd

Add: No.68, Hong Shan Yuan Road, Gulou District,
Fuzhou Municipality, Fujian Province, P.R. China.

Tel: +86-591-88077077

Fax: +86-591-88077085

ZIP: 350003

<http://www.landicorp.com>

