



Smart Cash Register Terminal

Model: AECR C10

Name: AECR C10



Contents

1. Disclaimer	4
2. Introduction	5
2.1 Safety Notices before Installation or Use	5
2.2 Product Configuration	6
2.3 Operating Environment	7
2.4 Dimension and Weight.....	7
3. Unpacking	7
4. Components	8
5. Installation.....	10
5.1 Checking Environment for Installation.....	10
5.2 Ports Description.....	10
5.3 Micro USB	11
5.4 MicroSD Memory Card	12
5.5 SAM Card	12
5.6 Peripheral Cable Connections	13
5.7 Debugging and Trial Operation	14
6. Usage Instruction	15
6.1 Power On/Power Off the Terminal	15
6.2 Keypad Function	15
6.3 Reading Cards	16
6.4 Smart Card.....	16
6.5 Contactless Card	17
6.6 PIN Pad	18
6.7 USB Port	19
6.8 Fingerprint Identification.....	19
6.9 Camera	20
6.10 Usage of Printer.....	21
7. Standard	23



8. Maintenance..... 25

- 8.1 MSR and Smart Card Reader Maintenance 25
- 8.2 Printer Maintenance 25
- 8.3 Troubleshooting.....26

9. Notices27

10. Transport and Storage 28

11. Others..... 29

- 11.1 Product accessories can be sold separately.....29
- 11.2 Customer Service.....29
- 11.3 Customer Service Address29



1. Disclaimer

- Care has been taken to ensure that the content of this document is as accurate as possible. Fujian LANDI however declines any responsibility for inaccurate, incomplete or outdated information.
- This document is copyrighted. All rights are reserved. Fujian LANDI reserves the right to modify the software, hardware or manual of this product at any time without notice.
- Due to the upgrade of the product, some of the details of this document may be inconsistent with the product. Fujian LANDI reserves the finally explanatory rights.
- Any reproduction, excerpt, backup, modification, transmission, translation or commercial use of this document or any portion of this document, in any form or by any means, without the prior written consent of Fujian LANDI is prohibited. Otherwise, it will retain the right to pursue the legal liability.
- Fujian LANDI shall not be liable for any damages, failures and data loss to device or accessories resulting from improper operation not in accordance with the instructions of this guide.

Documentation Conventions:



Danger: This symbol means that it is harmful to the safety of person and property.



Caution: This symbol means that you must be extremely careful not to do some things that may damage the device.



Notice: This symbol brings your attention to some helpful suggestions and references.



2. Introduction

2.1 Safety Notices before Installation or Use

- The terminal must be installed following the instructions stated in this manual. Connect the power cable to the power socket. Make sure that the ground wire of the power socket is connected to the earth. And sockets should be avoided with copying machine, air conditioner and other machine switched frequently in the same circuit. Please keep this manual in good for future use
- Do not use any other adapter. The use of mismatched adapter may damage your terminal.
- If the power cable is broken, please stop using it immediately and contact the customer service.
- Do not splash any liquid material or fall into the conductive objects, such as pins and wires; otherwise it will cause short circuits and damage the terminal.
- Do not load or place anything on the terminal.
- Do not shake or knock the terminal.
- Keep the terminal far from high temperature, dust, moist and electromagnetic field.
- Do not plug in or out any parts or peripherals in charging state. Please turn off the power before cutting off the power.
- Do not use or place flammable aerosols or paint to avoid fire.
- Turn off the power immediately once any fault happens. Never try to disassemble and fix the terminal by yourself, contact our customer service for help if necessary.
- Cut off the power supply of the terminal in case of lightning strike in lightning weather.
- When the terminal is attacked illegally (e.g. opening the casing), the sensitive information stored in the terminal will be immediately erased. Please do not open the casing so as to avoid unnecessary trouble.
- When the terminal is attacked illegally, there will be obvious alarm information on the screen and alarm sound. Please contact the customer service.

Introduction

AECR C10 is a new generation of smart cash register terminal designed by Fujian LANDI, configured with touch screen and high-speed communications, mainly used in indoor environment.

As a smart cash register terminal, AECR C10 integrates the function of cash register and financial payment, which has passed various industrial security evaluations, including PCI PTS 5.0, EMV L1&L2, to ensure the transaction security. Based on the same hardware, software and industrial design, AECR C10 has novel appearance and friendly interface, using Octa-Core 2.0GHz high-speed CPU, large capacity memory, large touch screen, high-speed printer with cutter, a high-resolution camera supporting 1D/2D scanning, to deliver enjoyable customer experience. AECR C10 supports a variety of communication modes, WIFI and BT are the standard configuration.

2.2 Product Configuration

AECR C10 Model

Mode	Name	Notes
AECR C10	Smart Cash Register Terminal	

AECR C10 Configuration

AECR C10 series offer as many functional configurations as possible to meet different demands of the customers, hence the product configuration differ. Please contact the customer manager for more details.

Product Configuration	Description	Notes
15.6" Dual Monitor	15.6" Main Screen+15.6" Customer Display	
DIGITAL TUBE	15.6" Main Screen +Led Digital Tube	

2.3 Operating Environment

Operating and Storage Conditions

Temperature	Ambient Temperature	-10℃~40℃
	Storage Temperature	-20℃~70℃
Relative Humidity	Operating Humidity	5%~90%, Non-condensing
	Storage Humidity	5%~90%, Non-condensing
Air Pressure		86kPa~106 kPa Altitude: <2000m

2.4 Dimension and Weight

Customer display	Weight(g)	L(mm)×W(mm)×H(mm)
15.6" Customer Display	≈7000	403×225×390
LED Digital Tube	≈5010	403×225×380

3. Unpacking

Please check carefully whether the terminal and fittings are disassembled or damaged. AECR C10 is a secure payment product, any disassembling behavior may lead to its failure to use.

1. The following items are included in AECR C10 box.

- ✧ AECR C10 terminal
- ✧ Power Adapter
- ✧ User guide

2. Disassemble all the packaging of the terminal and accessories.

3. You are recommended to keep all the packaging of AECR C10 for further packing or shipment if needed in the future.

4. Components

15.6" Dual Monitor

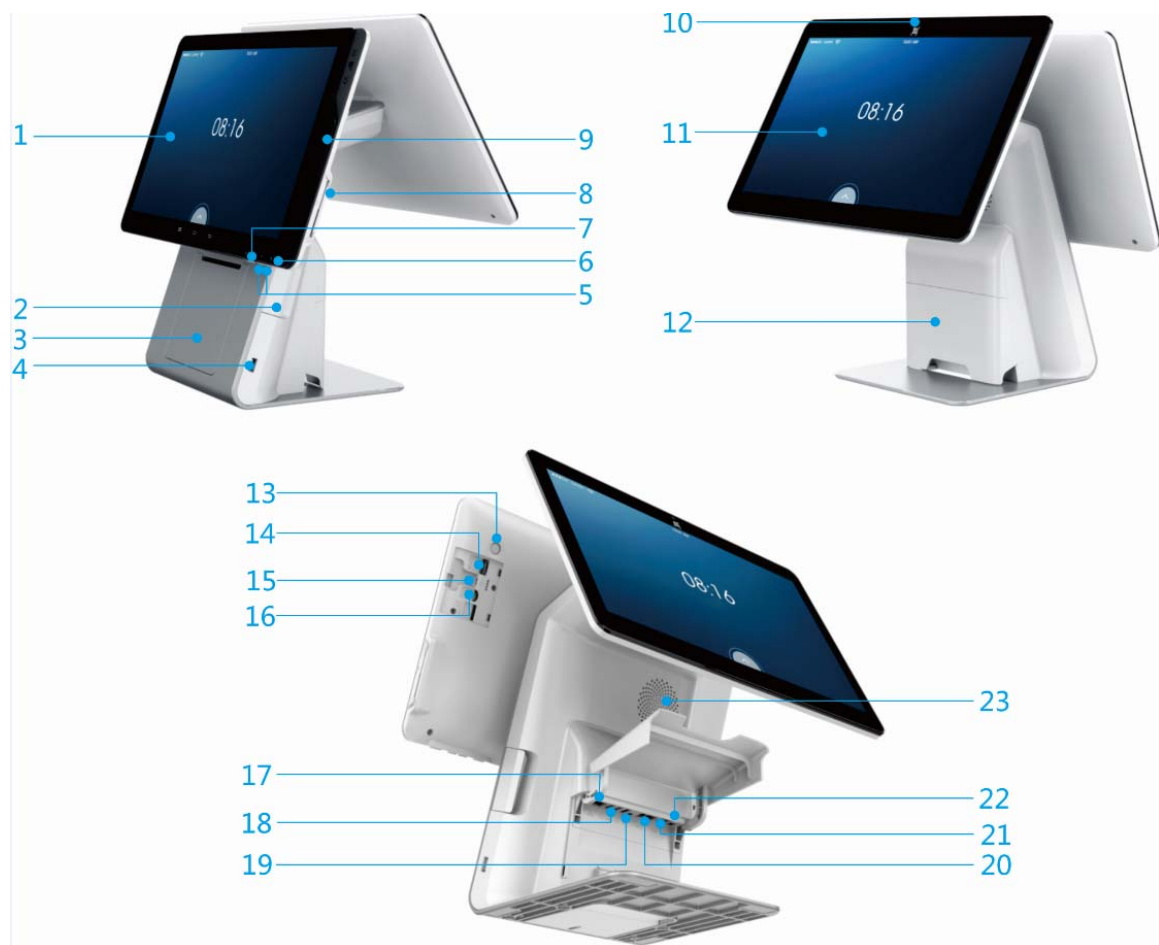

Figure 4-1

- | | |
|--|-------------------------------|
| 1. Main Screen (LCD and touch panel) | 2. Buckle of paper roll cover |
| 3. Paper roll cover | 4. Side USB port |
| 5. Volume Keys | 6. Power Key |
| 7. Cash drawer button | 8. Smart card reader |
| 9. Magnetic card reader | 10. Camera |
| 11. Customer Display (LCD and touch panel) | 12. Cable outlet cover |
| 13. Finger print reader | 14. SAM card slot |
| 15. Micro USB port | 16. Micro SD slot |
| 17. LAN (Ethernet) port | 18. USB port |
| 19. Headphone jack | 20. RS232 port |
| 21. Cash drawer port | 22. DC power supply |
| 23. Speaker | |

LED Digital Tube:



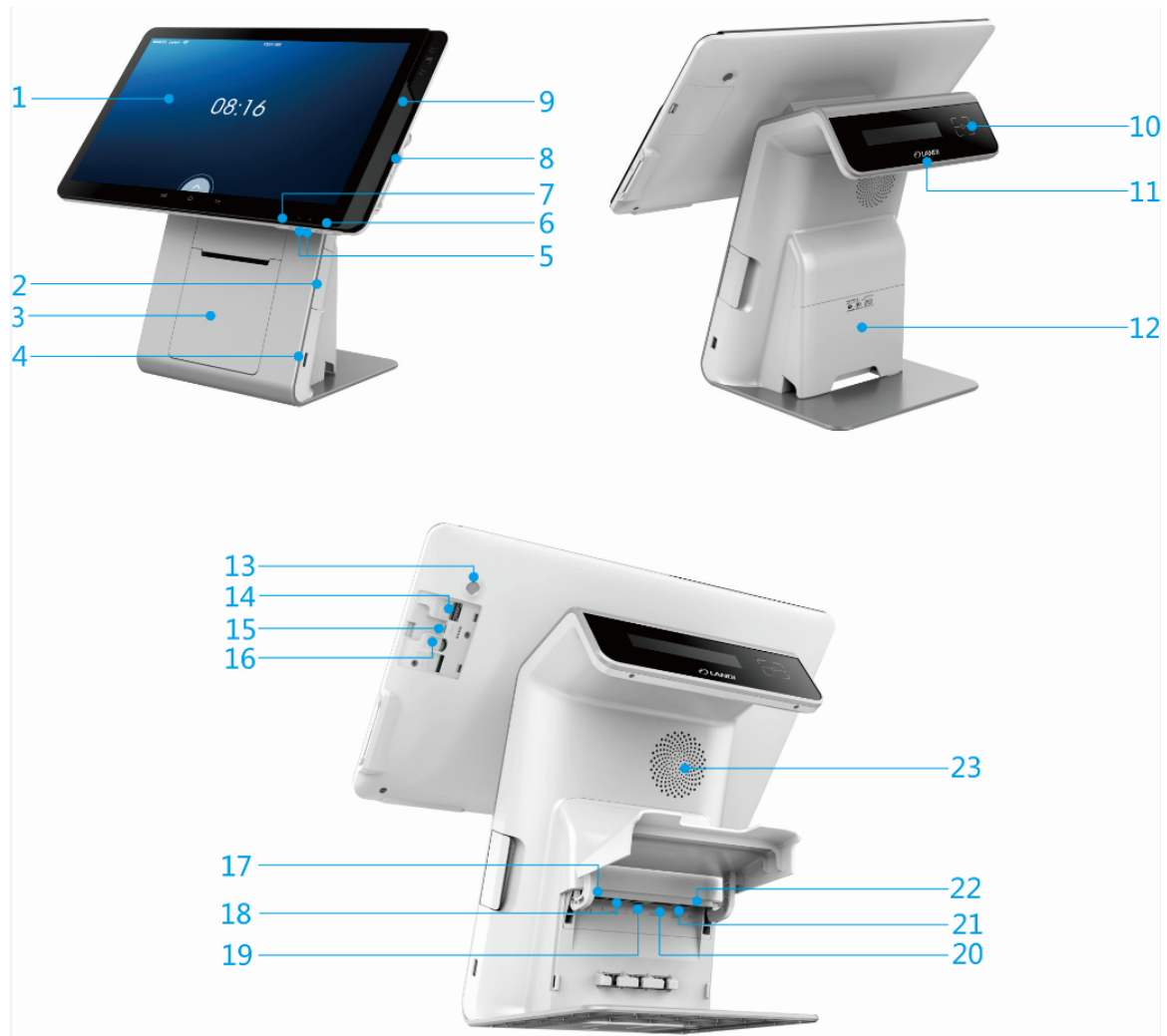

Figure 4-2

- | | |
|--------------------------------------|-------------------------------|
| 1. Main Screen (LCD and touch panel) | 2. Buckle of paper roll cover |
| 3. Paper roll cover | 4. Side USB port |
| 5. Volume Keys | 6. Power Key |
| 7. Cash drawer button | 8. Smart card reader |
| 9. Magnetic card reader | 10. Camera |
| 11. LED DIGITAL TUBE | 12. Cable outlet cover |
| 13. Finger print reader | 14. SAM card slot |
| 15. Micro USB port | 16. Micro SD slot |
| 17. LAN (Ethernet) port | 18. USB port |
| 19. Headphone jack | 20. RS232 port |
| 21. Cash drawer port | 22. DC power supply |
| 23. Speaker | |

5. Installation

5.1 Checking Environment for Installation

Place the terminal onto a desk or table big and stable enough to support the weight of the system and peripherals to prevent it from dropping down. The terminal should be in the environment far away from heat source, and free from moisture, electromagnetic and electrical devices (e.g. PC screen and electric motor, etc.).



Notice: Do not arrange power cables along the pedestrian walkway or across the channel on the floor for the sake of safety.

5.2 Ports Description

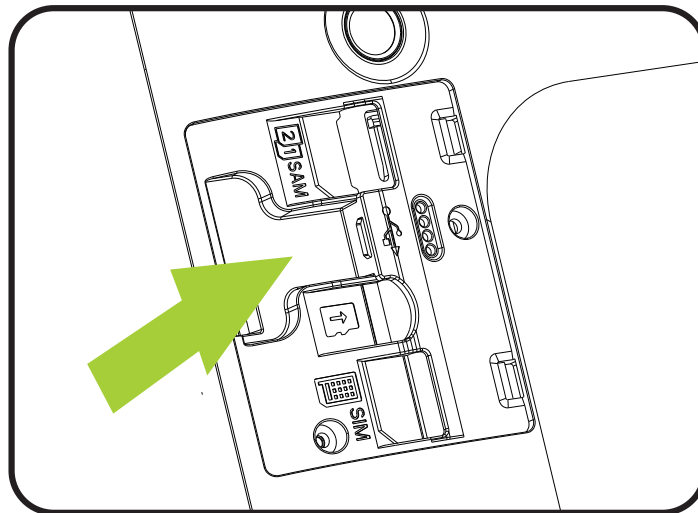

Figure 5-1

When the rear trapdoor is removed, the slots from top to bottom are as follows: SAM card reader, Micro USB port, TF card reader.



Caution: The ports of terminal must not be connected wrongly. The terminal cannot be used properly because of any error connections.

5.3 Micro USB

Micro USB is only used as a slave device to connect the computer to debug and copy data.

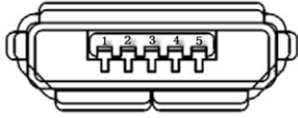

Pin	Definition	Description
1	VBUS	5V
2	D-	Differential Data, Negative
3	D+	Differential Data, Positive
4	ID	NC
5	GND	Ground



Notice: When the AECR C10 is connected to the computer, the Ethernet and the USB Type-A connections are temporarily disabled. The connection will be resumed automatically when the AECR C10 is disconnected to the computer.

5.4 MicroSD Memory Card

The seat of MicroSD Memory card is friction type. Please install the card in the direction of the arrow as shown in the following figure.

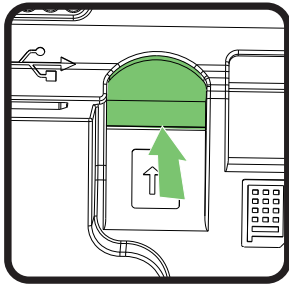

1. Turn the terminal and remove the rear trapdoor.

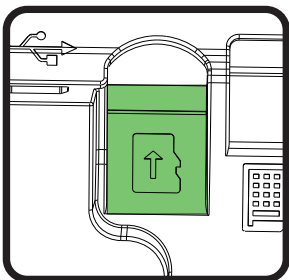

2. Insert MicroSD card and then close the cover and pull forwards. Be sure to put the MicroSD card contacts downside and the cut corner as indicated on the figure.

3. Close the trapdoor.



CAUTION: Switch off the terminal before opening the trapdoor.

5.5 SAM Card

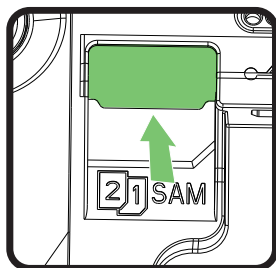

1. Turn off the terminal and remove the trapdoor.

2. Take the installed preciously SAM card out of the slot (If the SAM card was not installed before, please skip the step).

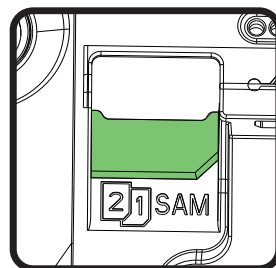

3. When introducing a SAM in its slot, be sure to put the cut corner as indicated on the picture.

4. Close the trapdoor.

5.6 Peripheral Cable Connections

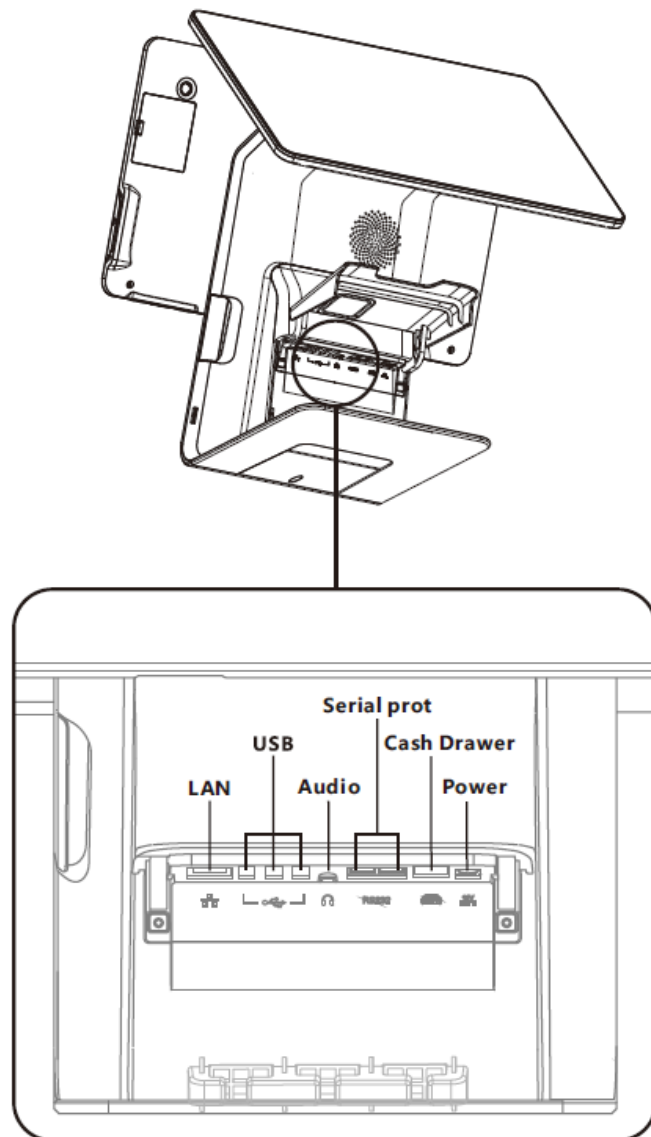

Figure 5-5

When the cover behind the base is removed, the ports from left to right are as follows: RJ45 Internet port, USB Type-A port, audio port, RS232 port, Cash drawer port and DC-In port.



Notice: Please put the power cable, USB cable and Ethernet cable in the slot of the back cover to prevent the cables from being scattered.

5.7 Debugging and Trial Operation

Debugging and Trial Operation

1. Check if the power cable is properly connected. When the power supply is functional, the red light will be on.
2. Check if the communication cable, SAM card (if necessary) and SIM card (if necessary) are properly installed.
3. Press the power button and observe the system led is from red to blue. If the button has been pressed but the terminal has no any response, please refer to the "Trouble shooting".
4. After the installation of the equipment, please have a trial operation.

6. Usage Instruction

6.1 Power On/Power Off the Terminal

Power on: Make sure the power adapter is correctly connected and press <Power> button more than 3s. The power indicator flickers from red to blue. The main display will show the root screen.

Power off: Press <Power> button for more than 2s until the screen displays the following figure, select <Power off> then press it.

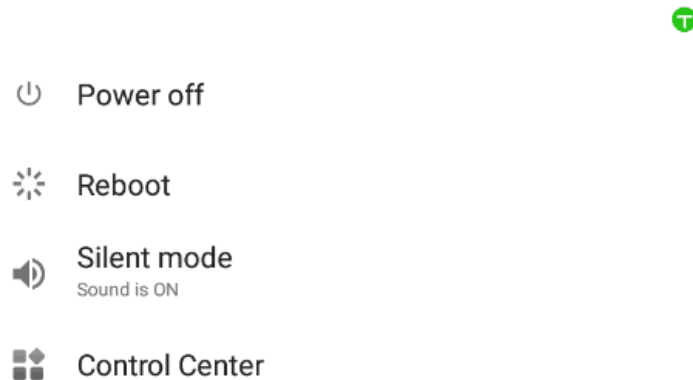

Figure 6-1

The power indicator flickers from blue to red when the terminal is turned off normally.

6.2 Keypad Function

The terminal has four physical keys in total. They are placed at the lower right corner of the Main Screen. The function of the buttons is displayed on the screen, which is convenient to use.



Figure 6-2

Power Button: To turn on/off the terminal (press for some seconds) and lock/unlock the screen (press in a short time).

Volume Keys: To adjust system volume.

Cash Drawer button: To open the cash drawer quickly. The access right to the drawer is controlled by software.

6.3 Reading Cards

Magnetic stripe card

The card can be read bi-directionally, with the stripe facing down. Use a regular movement in order to ensure a reliable card reading.

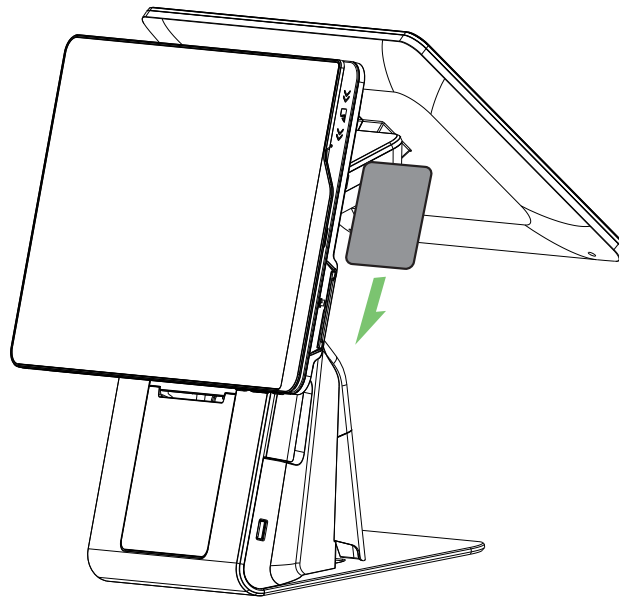

Figure 6-3

Unacceptable magnetic card:

1. Being curved.
2. Deformation and edge deflection.
3. The magnetic stripe is obviously damaged, scratched or out of magnetic.

6.4 Smart Card

Insert the smart card vertically with the metal chip facing the operator and keep it in position throughout the transaction.

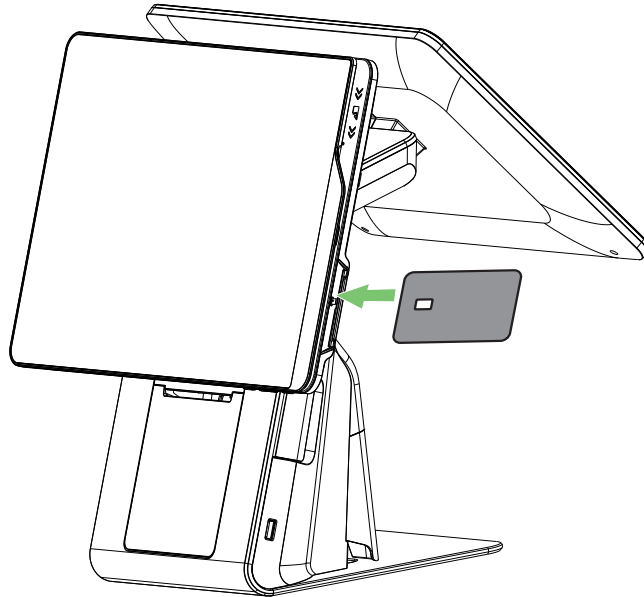

Figure 6-4



Notice: If the chip contacts of the smart card are damaged or oxidized, it may cause transaction failure.

6.5 Contactless Card

Place the card right against the sensing area. Keep the card close to the reader during the transaction. You can remove the card when the transaction is completed.

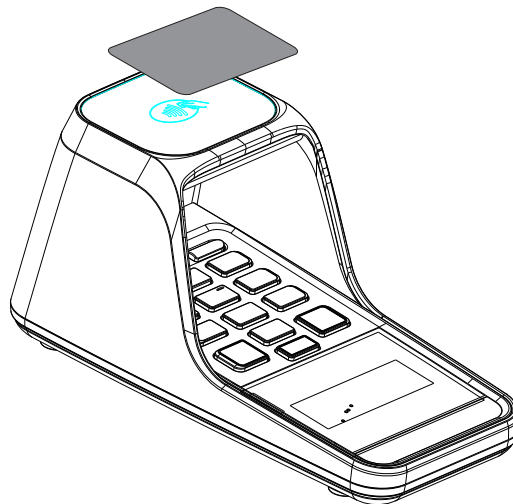

Figure 6-5



Notice: Different version product has different contactless card configuration. Please consult local department as per your needs.

6.6 PIN Pad

AECR C10 is a countertop device with large screens. In order to ensure payment security, password input is completed through a dedicated PIN Pad.

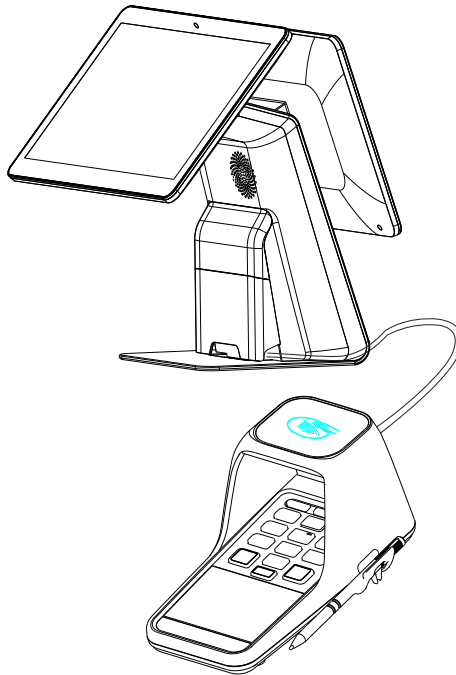

Figure 6-6

6.7 USB Port

The terminal has four USB Type-A ports in total. The one with power output of 5V/1.5A, located at the right side of the base, is recommended for frequently used USB device (e.g. flash disk) or high-power USB devices. The others all with power output of 5V/0.5A, located behind the base are recommended for USB devices that are not plugged in/out frequently (e.g. PIN Pad, scanners etc.).

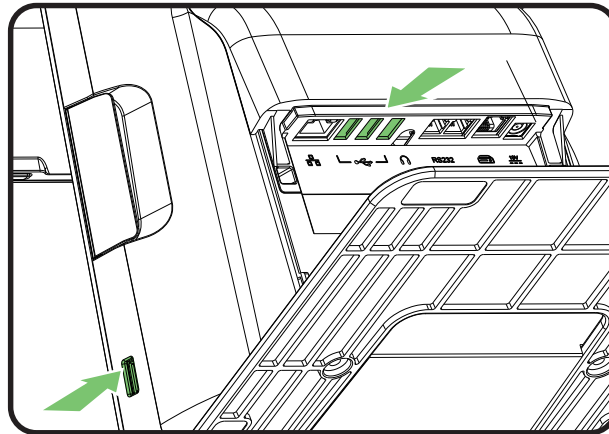

Figure 6-7

6.8 Fingerprint Identification

Fingerprint identification module located behind the Main Screen can be used for login, authorization and so on.

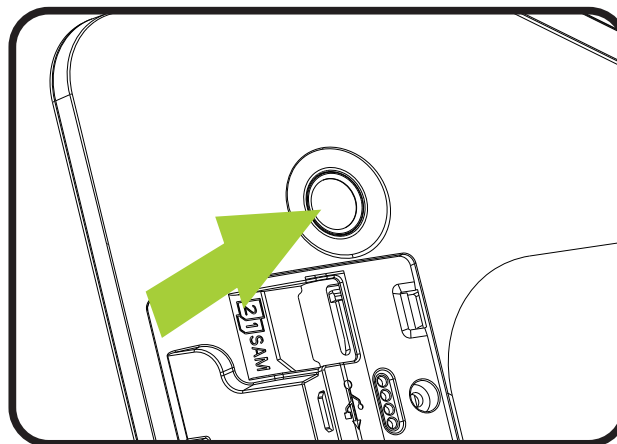

Figure 6-8



Notice: Please keep the fingerprint module surface clean.

6.9 Camera

15.6" Dual Monitor

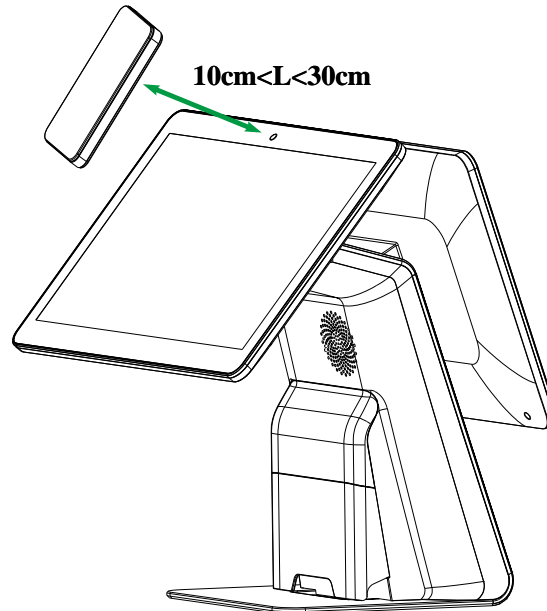

Figure 6-9

LED Digital Tube

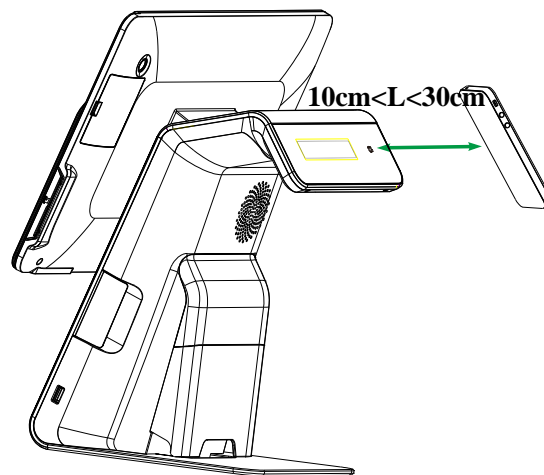

Figure 6-10

Photographing

The LCD screen will preview the current status when the camera is started. Press the button on the screen to complete the process of photographing.

1. Scan

1D Code: Code 128, Code 93, UPC/EAN/JAN, CODABAR

2D Code: QR CODE, PDF417

2. Usage of Scanner

- a. The brightness of the mobile phone must be set to the max value or not less than 2/3 of the maximum brightness.
- b. The vertical distance between the mobile phone screen and the front scanner head should be in range of 10 ~ 30 cm; 20 cm is the best distance.
- c. After scanning succeeds, the terminal will send success prompt or voice prompt.



Notice: Please keep the camera clean and prevent the lens from being scratched by sharp objects.

6.10 Usage of Printer

Installing paper roll

1. Paper roll characteristics

The paper roll can be purchased in stationery store. If the users need to purchase or customize their own paper roll, they can refer to the following size specifications.

Width: 80mm

Thickness: 80μm

Diameter: 80mm

The carbonized layer of the paper roll should follow the way as Figure 6-11.

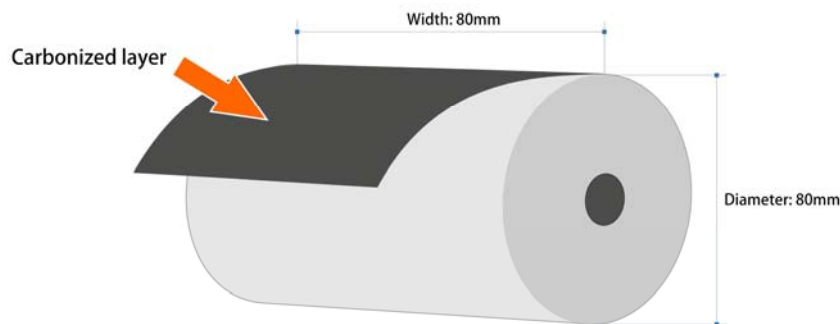
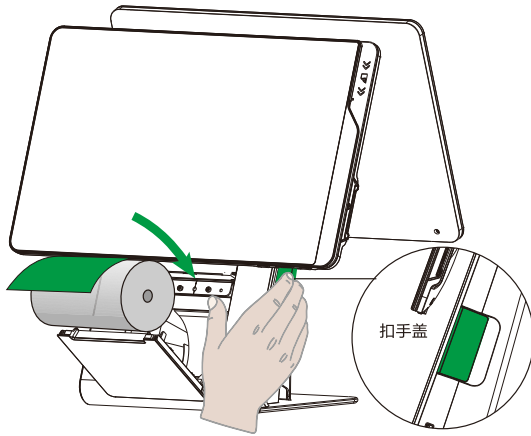

Figure 6-11



Notice: The quality of the paper roll will affect the printing display. Please do not use inferior paper roll to avoid inconvenience.

2. Installing paper roll



1. Pull the buckle of the paper roll cover.

2. Insert the paper roll in the compartment following the directions show on the below picture.

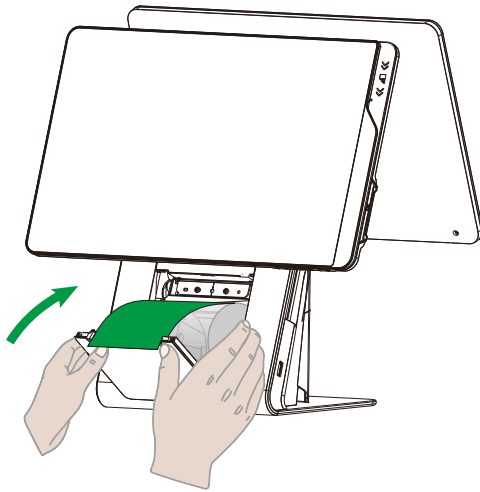

3. Pull the paper up to the top of the terminal, maintain the paper and close the cover.

4. Press simultaneously on both upper corners of the paper flap until it clips into position.

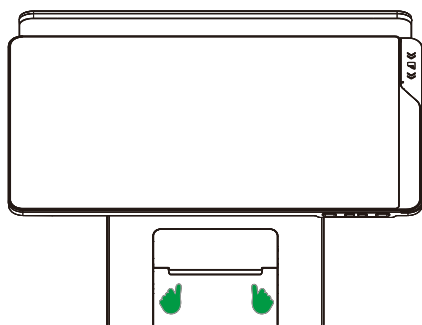

5. Press both sides of the cover at the same time with both hands. Make sure that both sides of the cover are buttoned.



Notice: Please make sure that paper roll cover is buttoned with the entire panel, otherwise it may lead to poor printing or failing to recognize the paper roll.

7. Standard

CE Marking

The CE marking indicates AECR C10 complies with the requirements of European Directive RED on Radio Equipment for:

- ✧ The protection of the health and the safety of the user and any other person.
- ✧ The protection requirements with respect to electromagnetic compatibility.

And complies with harmonised standards.

Operating Frequency Band (RF):

Wi-Fi: 2412-2472MHz/5150-5250MHz/5250-5350MHz/5470-5725MHz 5725-5850MHz
(TX/RX)

Bluetooth: 2402-2480 MHz(TX/RX)

Max. Of Transmit power:

2.4G Wi-Fi: 17.39dBm (802.11b), 16.33dBm (802.11g), 16.68dBm (802.11n20), 15.46dBm (802.11n40)

5G Wi-Fi:

Band1: 19.97dBm(802.11a), 19.97dBm(802.11n20), 21.40dBm(802.11n40),
15.80dBm(802.11ac80)

Band2: 20.56dBm(802.11a), 19.98dBm(802.11n20), 21.75dBm(802.11n40),
15.43dBm(802.11ac80)

Band3: 20.33dBm(802.11a), 20.18dBm(802.11n20), 21.52dBm(802.11n40),
15.94dBm(802.11ac80)

Band4: 13.69dBm(802.11a), 13.67dBm(802.11n20), 13.60dBm(802.11n40),
13.66dBm(802.11ac80)

Bluetooth: 15.34dBm BLE: 5.92dBm

Others

The functions of Wireless Access Systems including Radio Local Networks(WAS/RLANs) within the band 5150-5350 MHz for this device are restricted to indoor use only within all European Union countries

(BE/BG/CZ/DK/DE/EE/IE/EL/ES/FR/HR/IT/CY/LV/LT/LU/HU/MT/NL/AT/PL/PT/RO/SI/SK/FI/SE/UK)

FCC Warning

Any Changes or modifications not expressly approved by the party responsible for compliance could void the user's authority to operate the equipment.

This device complies with part 15 of the FCC Rules. Operation is subject to the following two conditions: (1) This device may not cause harmful interference, and (2) this device must accept any interference received, including interference that may cause undesired operation.

Note: This equipment has been tested and found to comply with the limits for a Class B digital device, pursuant to part 15 of the FCC Rules. These limits are designed to provide reasonable



protection against harmful interference in a residential installation. This equipment generates, uses and can radiate radio frequency energy and, if not installed and used in accordance with the instructions, may cause harmful interference to radio communications. However, there is no guarantee that interference will not occur in a particular installation. If this equipment does cause harmful interference to radio or television reception, which can be determined by turning the equipment off and on, the user is encouraged to try to correct the interference by one or more of the following measures:

- ✧ Reorient or relocate the receiving antenna.
- ✧ Increase the separation between the equipment and receiver.
- ✧ Connect the equipment into an outlet on a circuit different from that to which the receiver is connected.
- ✧ Consult the dealer or an experienced radio/TV technician for help.

FCC Radiation Exposure Statement:

- ✧ This equipment complies with FCC radiation exposure limits set forth for an uncontrolled environment .
- ✧ This transmitter must not be co-located or operating in conjunction with any other antenna or transmitter.
- ✧ This equipment must be installed and operated in accordance with provide instructions and the antenna used for this transmitter must be installed to provide a separation distance of at least 20 cm from all persons and must not be co-located or operation in conjunction with any other antenna or transmitter. End-users and installers must be provide with antenna installation instructions and transmitter operating conditions for satisfying RF exposure compliance.

Environment (WEEE, Batteries and packaging)

This product is labeled in accordance with European Directives 2002/96/EC concerning Waste Electrical and Electronic Equipment (WEEE) and 2006/66/EC concerning Batteries and Accumulators. Those provisions are requiring producers and manufacturers to become liable for take-back, treatment and recycling upon end of life of equipment and batteries.

BATTERIES

If your product contains batteries, they must be disposed of at appropriate collection points.

THE PRODUCT



The crossed-out waste bin stuck on the product or its accessories means that the product belongs to the family of electrical and electronic equipment, and waste batteries must not be thrown away but collected separately and recycles.

Please contact your retailers for more detailed information about the compliance solution in place for disposing of your old product and used batteries.



Packaging waste must also be collected separately to assure a proper disposal and recycling.

In this way you can participate in the re-use and upgrading of Electrical and Electronic Equipment Waste, which can have an effect on the environment and human health.

8. Maintenance

8.1 MSR and Smart Card Reader Maintenance

- ✧ Do not attempt to clean the magnetic card reader and smart card reader, for this action may result in damage to the terminal, and that cause warranty invalid.

8.2 Printer Maintenance

- ✧ Do not try to pull up the paper roll under any circumstances.
- ✧ If paper jam occurs, please pull the buckle and open the paper roll cover. The paper jam will be removed automatically.
- ✧ If the distance of printing paper from the printer should be adjusted, please shut down the terminal and place the printing paper in the right way.
- ✧ Dust or wastepaper remnant in the printer will reduce the efficiency. Please use soft brush to clean it (Be careful not to scratch the printer head).

8.3 Troubleshooting

Question	Explanation	Action
Terminal cannot be started	Abnormal power supply	<ol style="list-style-type: none"> 1. Make sure the power adapter is correctly connected and the power indicator is red. 2. Make sure the button is pressed more than 3s. 3. If it still fails, please contact our customer service for help.
Screen cannot display	1. Power is not enough.	<ol style="list-style-type: none"> 1. Check whether power cable plugs tightly. 2. Disconnect the power cable and reconnect it. 3. If it still fails, please contact our customer service department for help.
Printer cannot work	<ol style="list-style-type: none"> 1. Abnormal power supply. 2. Incorrect paper installation. 	<ol style="list-style-type: none"> 1. Check whether the power is on. 2. Check if it is out of paper or if the paper roll is correctly installed. 3. Check whether the paper roll cover is fully closed. 4. If the problem still exists, please contact our customer service center.
Peripheral device cannot work	<ol style="list-style-type: none"> 1. Abnormal power supply. 2. Broken cable 	<ol style="list-style-type: none"> 1. Check the power cable connected to the peripheral device. 2. Check whether the peripheral device is connected to the power supply and work properly. 3. Please try to replace a cable and reconnect it with reference to device connections. 4. If the problem still exists, please contact our customer service center.
Transaction Processing Failure	<ol style="list-style-type: none"> 1. Damaged MSR card. 2. Operate the card improperly. 3. Damaged MSR card reader. 4. Damaged smart card 5. Damaged SAM card or unconnected. 6. 	<ol style="list-style-type: none"> 1. Try to use more than one magnetic card to test the transaction, to confirm the failure is not caused by magnetic card. 2. Make sure card swiping is operated correctly. 3. Manually process the transaction instead of using card reader. If manually operated transaction works, the failure may be caused by magnetic card reader. 4. If the manual transaction fails, please check the communication status or check the smart card reader. 5. Use more than one smart card to test the transaction, to confirm the failure is not caused by the smart card. 6. Make sure the SAM card is correctly inserted into

	Communication breakdown.	<p>the card slot.</p> <p>7. Check if the SIM card is installed correctly and local wireless communication network functions or not.</p> <p>8. If there is communication breakdown, please contact the corresponding communication operator to solve the problem.</p> <p>9. If there is still problem, please contact our customer service.</p>
--	--------------------------	--

9. Notices

- ✧ Do not use the terminal in the environment with direct sunlight, high temperature, moisture or dust.
- ✧ Cut off the power supply before cleaning; use soft dry cloth to clean it. Cleaning terminal with a clean cloth dipped in one or two drops of neutral detergent to clean, not to use a damp cloth. For dirt difficult to remove, alcohol or alcoholic washing detergent can be used. Do not use thinner, trichlorethylene or keto solvents, because these chemicals will damage plastic or rubber parts.

- ✧ Do not plug in or out any parts in charging state (Except USB, Ethernet, headset).
- ✧ Do not plug in or out SIM card, SAM card, MicroSD card and so on.
- ✧ Do not plug out smart card during transaction process.
- ✧ Please shut down the terminal to save energy at the end of the daily operation.
- ✧ The terminal should be managed by specific person who is familiar with the terminal.
- ✧ Stop operation when there is abnormal phenomenon, shut down the power supply and inform the service provider:
 1. Harsh sound in operation.
 2. Pouring water or impurities into device accidentally.
 3. Bad smell in operation.



WARNING: The terminal is limited to indoor use. Any exposure to rain or dust for the terminal causing its malfunction is not within the scope of warranty.

10. Transport and Storage

Adopt general transportation mode, and prevent the goods from sunlight, snow, shower and mechanical impact. Transport the devices with care, do not throw it forcibly. Prevent the packaging from extrusion during transportation, to avoid breakage.



Notice: There are warnings for the transportation on the packaging box. Please follow the warnings during the transportation. Otherwise, it may cause damage to the terminal.

The product should be stored in the original packaging box. The warehouse is not allowed to have all sorts of harmful gases, inflammable, explosive, corrosive chemical goods, strong mechanical vibration and strong magnetic field. Packing box should be at least 15cm above the ground, and be away from heat, cold, window or air inlet source at least 50cm.

11. Others

11.1 Product accessories can be sold separately

We provide you with more kinds of accessories to meet the different requirements.

1. Paper roll
2. PIN Pad.
3. Cash drawer.
4. Micro SD card
5. Scanner

Note: please contact customer manager for more details.

11.2 Customer Service

Please refer to the contact information in the warranty list of the terminal, contact the nearest service point for maintenance. Please provide valid proof such as purchase invoice in case of maintenance.

11.3 Customer Service Address

Fujian LANDI Commercial Equipment Co., Ltd
Add: Building 17, Block A, Fuzhou Software Park,
No. 89 Software Road, Fuzhou, Fujian, China
Tel: +86-591-88077077
Fax: +86-591-88077085
ZIP: 350003
<http://www.landicorp.com>

