

FCC TEST REPORT

FCC ID: 2AG6FV10

Product : POS System

Model Name : V10,V6,V7,V8,V9

Brand : 

Report No. : PT800231151222E-FC04

Prepared for

CITAQ CO., LTD.
9th Floor, Chuangye Building, 6 Keji Middle Road,
New Hi-Tech Zone, Shantou, Guangdong China

Prepared by

DongGuan Precise Testing Service Co.,Ltd.
Building D, Baoding Technology Park, Guangming Road 2, Guangming Community
Dongcheng District, Dongguan, Guangdong, China



TEST RESULT CERTIFICATION

Applicant's name : CITAQ CO., LTD.
 Address : 9th Floor, Chuangye Building, 6 Keji Middle Road, New Hi-Tech Zone, Shantou, Guangdong China
 Manufacture's name : CITAQ CO., LTD.
 Address : 9th Floor, Chuangye Building, 6 Keji Middle Road, New Hi-Tech Zone, Shantou, Guangdong China
 Product name : POS System
 Model name : V10,V6,V7,V8,V9
 Standards : FCC CFR47 Part 15 Section B
 Test procedure : ANSI C63.4:2014
 Test Date : Dec. 25, 2015 ~ Jan.4, 2016
 Date of Issue : Jan.4, 2016
 Test Result : Pass

This device described above has been tested by PTS, and the test results show that the equipment under test (EUT) is in compliance with the FCC requirements. And it is applicable only to the tested sample identified in the report.

This report shall not be reproduced except in full, without the written approval of PTS, this document may be altered or revised by PTS, personal only, and shall be noted in the revision of the document.

Testing Engineer

August Qiu

Technical Manager

Hack Ye

Authorized Signatory

Chris Du



Contents

	Page
2 TEST SUMMARY.....	4
3 GENERAL INFORMATION.....	5
3.1 GENERAL DESCRIPTION OF E.U.T.....	5
3.2 TEST MODE.....	6
3.3 CONFIGURATION OF SYSTEM	6
4 EQUIPMENT DURING TEST	7
4.1 EQUIPMENTS LIST.....	7
4.2 DESCRIPTION OF SUPPORT UNITS.....	7
4.3 MEASUREMENT UNCERTAINTY.....	8
5 CONDUCTED EMISSION.....	9
5.1 E.U.T. OPERATION.....	9
5.2 EUT SETUP	9
5.3 MEASUREMENT DESCRIPTION.....	10
5.4 CONDUCTED EMISSION TEST RESULT	10
6 RADIATED SPURIOUS EMISSIONS	12
6.1 EUT OPERATION	12
6.2 TEST SETUP.....	13
6.3 SPECTRUM ANALYZER SETUP.....	14
6.4 TEST PROCEDURE.....	14
6.5 SUMMARY OF TEST RESULTS.....	15
7 TEST SETUP	18



2 Test Summary

Test Item	Test Requirement	Class	Test Method	Test Result
Power Line Conducted Emission (150kHz to 30MHz)	FCC PART 15, SUBPART B	Class B	ANSI C63.4: 2014	Pass
Radiated Emission (30MHz to 1GHz)	FCC PART 15, SUBPART B	Class B	ANSI C63.4: 2014	Pass
Radiated Emission (Above 1GHz)	FCC PART 15, SUBPART B	Class B	ANSI C63.4: 2014	Pass

Remark:

N/A: Not Applicable



3 General Information

3.1 General Description of E.U.T.

Product Name	:	POS System
Model Name	:	V10,V6,V7,V8,V9
Model Description	:	Only the model names are different
GSM Band(s)	:	GSM 850/1900
GPRS/EGPRS Class	:	12
WCDMA Band(s)	:	FDD Band II/V
Bluetooth Version	:	V4.0(with BLE)
Operating frequency	:	GSM/GPRS/EDGE 850: 824~849MHz PCS/GPRS/EDGE 1900: 1850~1910MHz WCDMA/UPA/DPA Band V: 824~849MHz WCDMA/UPA/DPA Band II: 1850~1910MHz Bluetooth: 2402-2480MHz WIFI 802.11b/g/n HT20:2412-2462MHz 802.11n HT40:2422-2452MHz
Max. RF output power	:	GSM 850: 32.35dBm PCS 1900: 29.18dBm WCDMA Band V: 22.66dBm WCDMA Band II: 22.47dBm Bluetooth: 2.04dBm WIFI: 9.42dBm
Type of Modulation	:	GSM,GPRS: GMSK EDGE: 8PSK WCDMA: QPSK Bluetooth: GFSK, Pi/4 DQPSK,8DPSK WIFI: CCK, OFDM
Antenna installation:	:	GSM/WCDMA: internal permanent antenna WIFI/Bluetooth: internal permanent antenna
Antenna Gain:	:	GSM 850/ WCDMA Band V: -0.5dBi PCS 1900/ WCDMA Band II: 1.2dBi WIFI: 0dBi Bluetooth: 0dBi
Power supply	:	DC 24V 2.71A Power by AC adapter
Adapter	:	Input:100-240V ~50/60Hz 1.7A max Output: DC 24V 2.71A

3.2 Test Mode

All test mode(s) and condition(s) mentioned were considered and evaluated respectively by performing full tests, the worst data were recorded and reported.

Test Item	Test Mode
Conduction Emission	working
Radiated Emission	working

3.3 Configuration of System

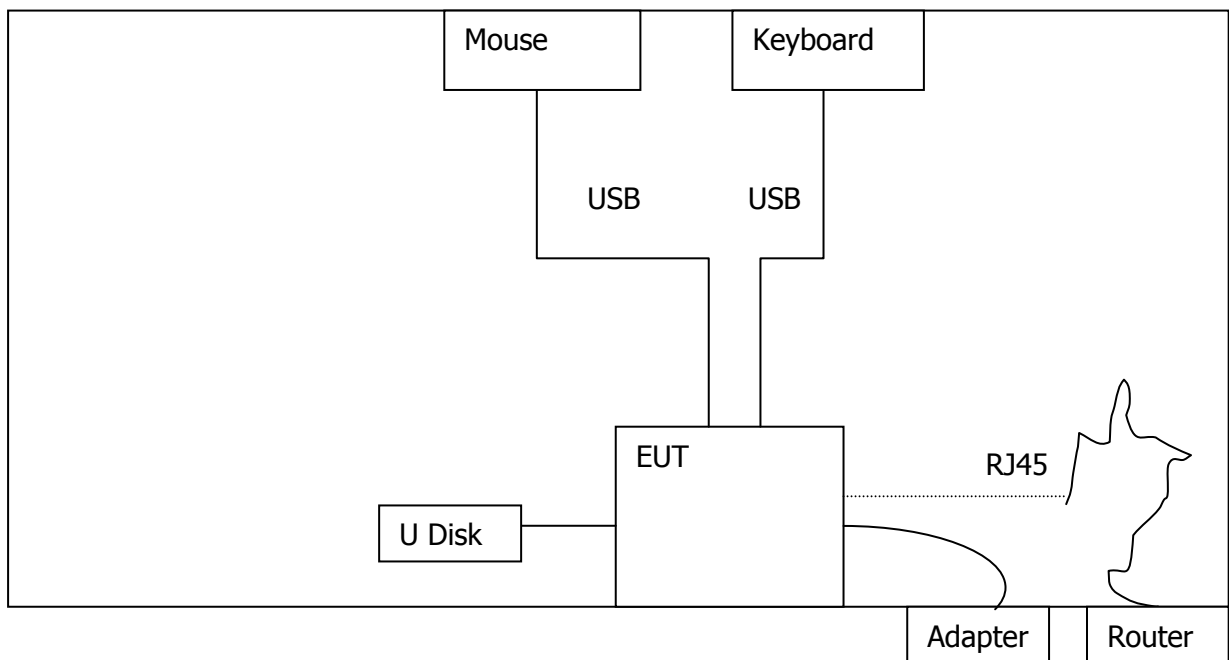



4 Equipment During Test

4.1 Equipments List

Radiated Emissions							
Item	Kind of Equipment	Manufacturer	Type No.	Serial No.	Last calibration	Calibrated until	Calibration period
1	EMI Test Receiver	Rohde&Schwarz	ESCI	101417	July 15, 2015	July 14, 2016	1 year
2	EMC Analyzer (9k~26.5GHz)	Agilent	E4407B	MY45109572	Aug.04, 2015	Aug.03, 2016	1 year
3	Trilog Broadband Antenna	SCHWARZBECK	VULB9160	9160-3355	July 15, 2015	July 14, 2016	1 year
4	Amplifier	EM	EM-30180	060538	July 15, 2015	July 14, 2016	1 year
5	Horn Antenna	SCHWARZBECK	BBHA9120D	9120D-1246	July 15, 2015	July 14, 2016	1 year
6	Coaxial Cable(below 1GHz)	LARGE	CALB1	-	July 15, 2015	July 14, 2016	1 year
7	Coaxial Cable(above 1GHz)	LARGE	CALB2	-	July 15, 2015	July 14, 2016	1 year
Conducted Emissions							
Item	Kind of Equipment	Manufacturer	Type No.	Serial No.	Last calibration	Calibrated until	Calibration period
1	EMI Test Receiver	R&S	ESCI	101155	July 15, 2015	July 14, 2016	1 year
2	LISN	SCHWARZBECK	NSLK 8128	8128-289	July 15, 2015	July 14, 2016	1 year
3	Coaxial Cable	LARGE	RF300	-	July 15, 2015	July 14, 2016	1 year

4.2 Description of Support Units

Equipment	Manufacturer	Model No.	Series No.
Mouse	Lisheng	M202	M-1101
Key board	Lisheng	KB202	KB-1102



4.3 Measurement Uncertainty

Parameter	Uncertainty
RF output power, conducted	±1.0dB
Power Spectral Density, conducted	±2.2dB
Radio Frequency	± 1 x 10 ⁻⁶
Bandwidth	± 1.5 x 10 ⁻⁶
Time	±2%
Duty Cycle	±2%
Temperature	±1°C
Humidity	±5%
DC and low frequency voltages	±3%
Conducted Emissions (150kHz~30MHz)	±3.64dB
Radiated Emission(30MHz~1GHz)	±5.03dB
Radiated Emission(1GHz~25GHz)	±4.74dB

5 Conducted Emission

- Test Requirement: : FCC CFR 47 Part 15 Section 15.107
- Test Method: : ANSI C63.4:2014
- Frequency Range: : 150kHz to 30MHz
- Class/Severity: : Class B
- Limit: : 66-56 dB μ V between 0.15MHz & 0.5MHz
 : 56 dB μ V between 0.5MHz & 5MHz
 : 60 dB μ V between 5MHz & 30MHz
- Detector: : Peak for pre-scan (9kHz Resolution Bandwidth)

5.1 E.U.T. Operation

Operating Environment :

- Temperature: : 25.5 °C
- Humidity: : 51 % RH
- Atmospheric Pressure: : 101.2kPa
- EUT Operation : : Refer to section 3.2

5.2 EUT Setup

The conducted emission tests were performed using the setup accordance with the ANSI C63.4:2014.

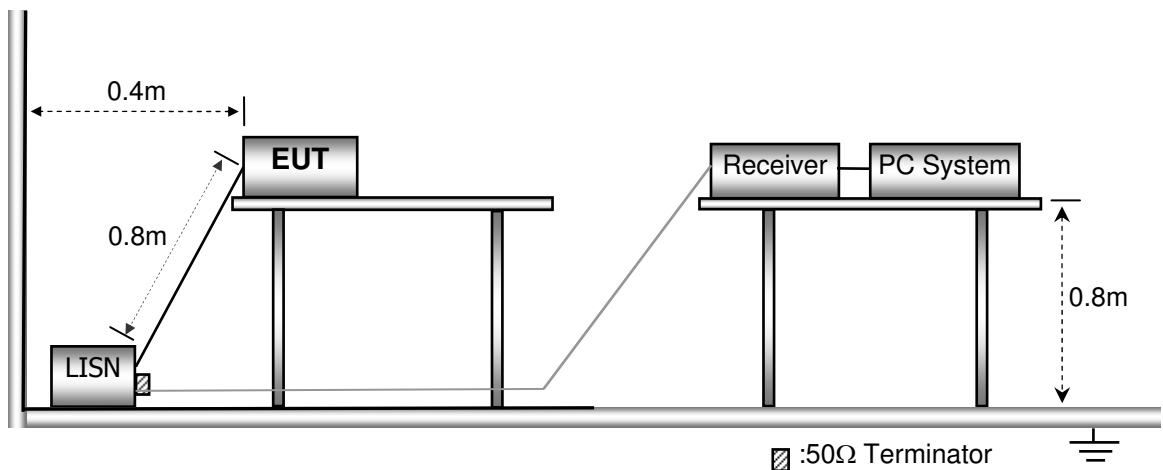



5.3 Measurement Description

The maximised peak emissions from the EUT was scanned and measured for both the Live and Neutral Lines. Quasi-peak & average measurements were performed if peak emissions were within 6dB of the average limit line.

5.4 Conducted Emission Test Result

Live line:

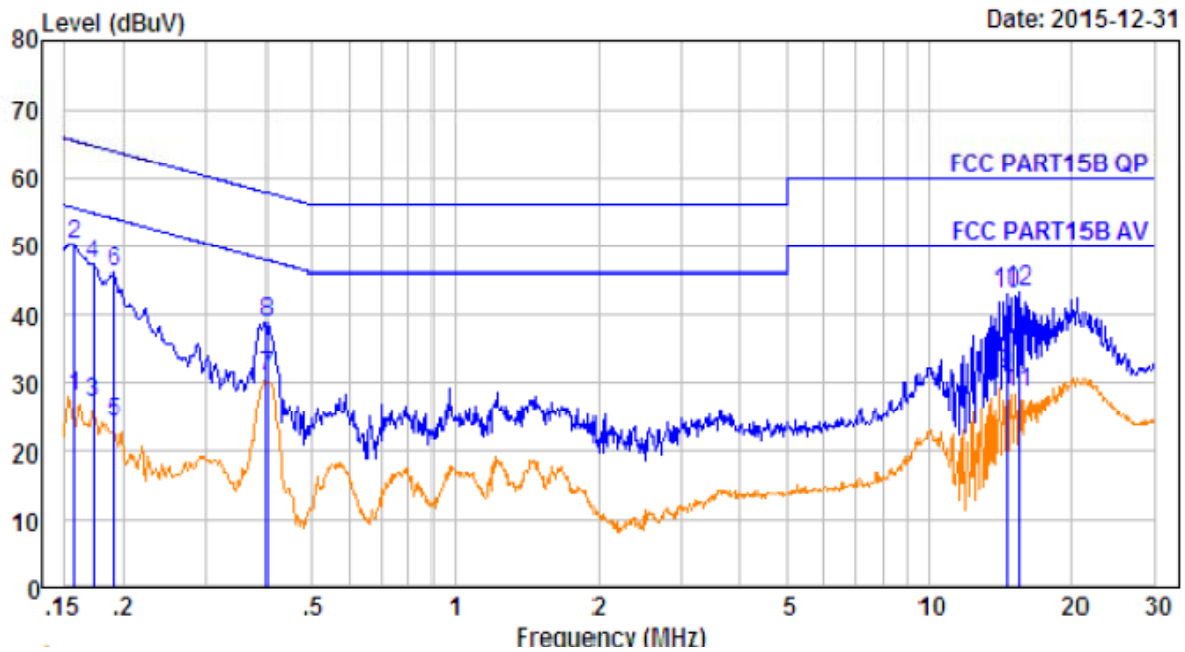

No.	Freq MHz	Cable Loss dB	AMN Factor dE	Receiver Reading dBuV	Emission Level dBuV	Limit dBuV	Over Limit dB	Remark
1.	0.158	10.60	0.60	16.93	28.13	55.56	-27.43	Average
2.	0.158	10.60	0.60	38.93	50.13	65.56	-15.43	QP
3.	0.174	10.60	0.60	16.02	27.22	54.77	-27.55	Average
4.	0.174	10.60	0.60	36.02	47.22	64.77	-17.55	QP
5.	0.190	10.61	0.60	12.97	24.18	54.02	-29.84	Average
6.	0.190	10.61	0.60	34.97	46.18	64.02	-17.84	QP
7.	0.402	10.64	0.60	19.69	30.93	47.81	-16.88	Average
8.	0.402	10.64	0.60	27.69	38.93	57.81	-18.88	QP
9.	14.594	10.77	0.60	19.77	31.14	50.00	-18.86	Average
10.	14.594	10.77	0.60	31.77	43.14	60.00	-16.86	QP
11.	15.470	10.77	0.60	17.16	28.53	50.00	-21.47	Average
12.	15.470	10.77	0.60	32.16	43.53	60.00	-16.47	QP



Neutral line:

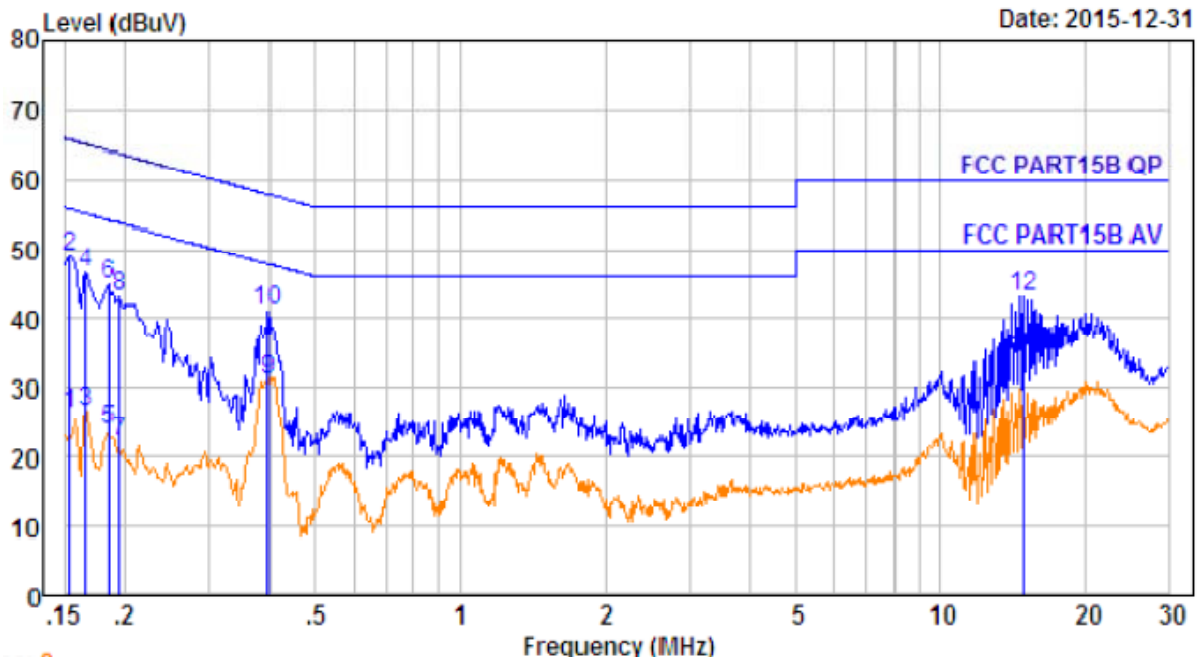

No.	Freq MHz	Cable Loss dB	AMN Factor dB	Receiver Reading dBuV	Emission Level dBuV	Limit dBuV	Over Limit dB	Remark
1.	0.154	10.60	0.60	14.95	26.15	55.78	-29.63	Average
2.	0.154	10.60	0.60	37.95	49.15	65.78	-16.63	QP
3.	0.166	10.60	0.60	15.50	26.70	55.16	-28.46	Average
4.	0.166	10.60	0.60	35.50	46.70	65.16	-18.46	QP
5.	0.186	10.61	0.60	12.77	23.98	54.20	-30.22	Average
6.	0.186	10.61	0.60	33.77	44.98	64.20	-19.22	QP
7.	0.194	10.61	0.60	10.88	22.09	53.84	-31.75	Average
8.	0.194	10.61	0.60	31.88	43.09	63.84	-20.75	QP
9.	0.398	10.64	0.60	19.85	31.09	47.90	-16.81	Average
10.	0.398	10.64	0.60	29.85	41.09	57.90	-16.81	QP
11.	14.907	10.77	0.60	22.86	34.23	50.00	-15.77	Average
12.	14.907	10.77	0.60	31.86	43.23	60.00	-16.77	QP



6 Radiated Spurious Emissions

Test Requirement: : FCC CFR47 Part 15 Section 15.109
 Test Method: : ANSI C63.4:2014
 Measurement Distance: : 3m
 Limit: : See the follow table

Frequency (MHz)	Field Strength		Field Strength Limit at 3m Measurement Dist	
	uV/m	Distance (m)	uV/m	dBuV/m
30 ~ 88	100	3	100	20log ⁽¹⁰⁰⁾
88 ~ 216	150	3	150	20log ⁽¹⁵⁰⁾
216 ~ 960	200	3	200	20log ⁽²⁰⁰⁾
Above 960	500	3	500	20log ⁽⁵⁰⁰⁾

6.1 EUT Operation

Operating Environment :
 Temperature: : 23.5 °C
 Humidity: : 51.1 % RH
 Atmospheric Pressure: : 101.2kPa
 EUT Operation : : Refer to section 3.2

6.2 Test Setup

The radiated emission tests were performed in the 3m Semi- Anechoic Chamber test site

The test setup for emission measurement from 30 MHz to 1 GHz.

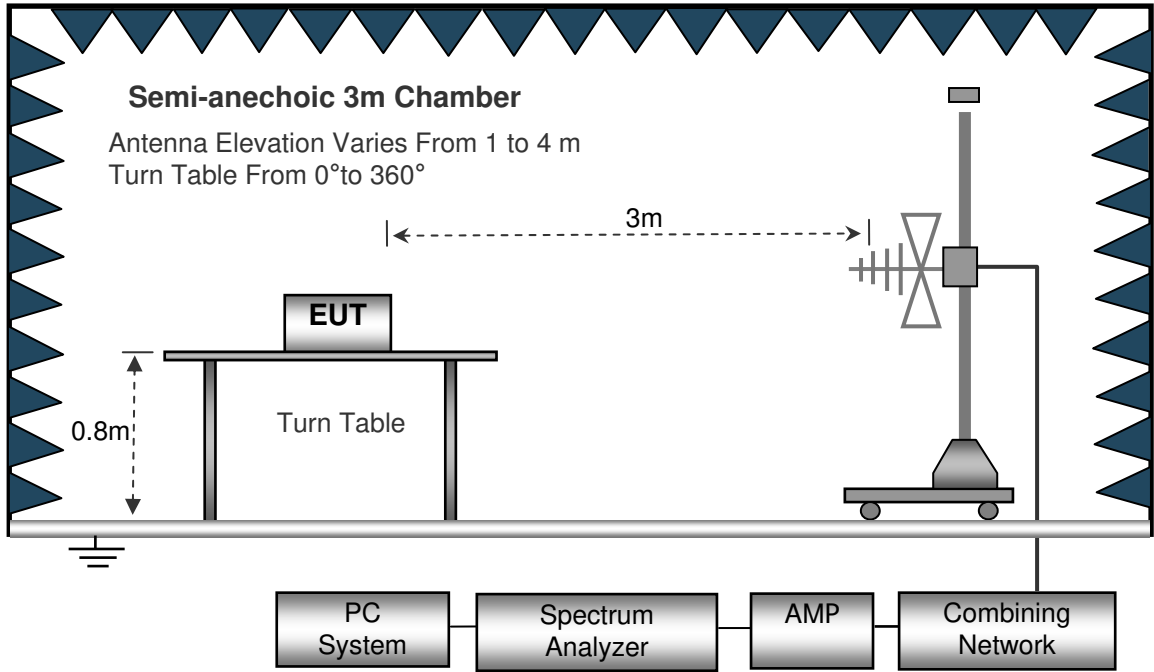

The test setup for emission measurement above 1 GHz.

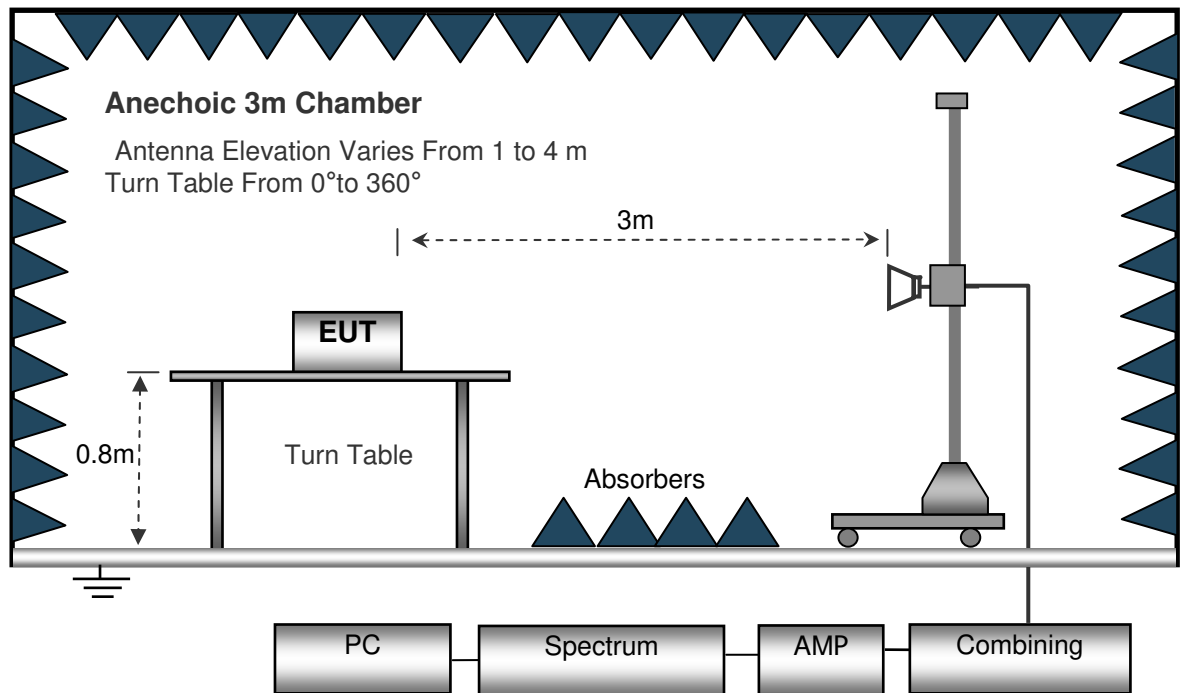



6.3 Spectrum Analyzer Setup

30MHz ~ 1GHz

- Sweep Speed : Auto
- Detector : PK
- Resolution Bandwidth : 100kHz
- Video Bandwidth : 300kHz
- Detector : QP
- Resolution Bandwidth : 120kHz
- Video Bandwidth : 300kHz

Above 1GHz

- Sweep Speed : Auto
- Detector : PK
- Resolution Bandwidth : 1MHz
- Video Bandwidth : 3MHz
- Detector : AV
- Resolution Bandwidth : 1MHz
- Video Bandwidth : 10Hz

6.4 Test Procedure

1. The EUT is placed on a turntable, which is 0.8m above ground plane.
2. The turntable shall be rotated for 360 degrees to determine the position of maximum emission level
3. EUT is set 3m away from the receiving antenna, which is moved from 1m to 4m to find out the maximum emissions. The spectrum was investigated from the lowest radio frequency signal generated in the device, without going below 9 kHz, up to the tenth harmonic of the highest fundamental frequency or to 40 GHz, whichever is lower.
4. Maximum procedure was performed on the six highest emissions to ensure EUT compliance.
5. And also, each emission was to be maximized by changing the polarization of receiving antenna both horizontal and vertical.
6. Repeat above procedures until the measurements for all frequencies are complete.
7. The radiation measurements are tested under 3-axes(X,Y,Z) position(X denotes lying on the table, Y denotes side stand and Z denotes vertical stand), After pre-test, It was found that the worse radiation emission was get at the X position. So the data shown was the X position only.



6.5 Summary of Test Results

Test Frequency: 30MHz ~ 1GHz

Antenna Polarization: Vertical

Date: 2015-12-31

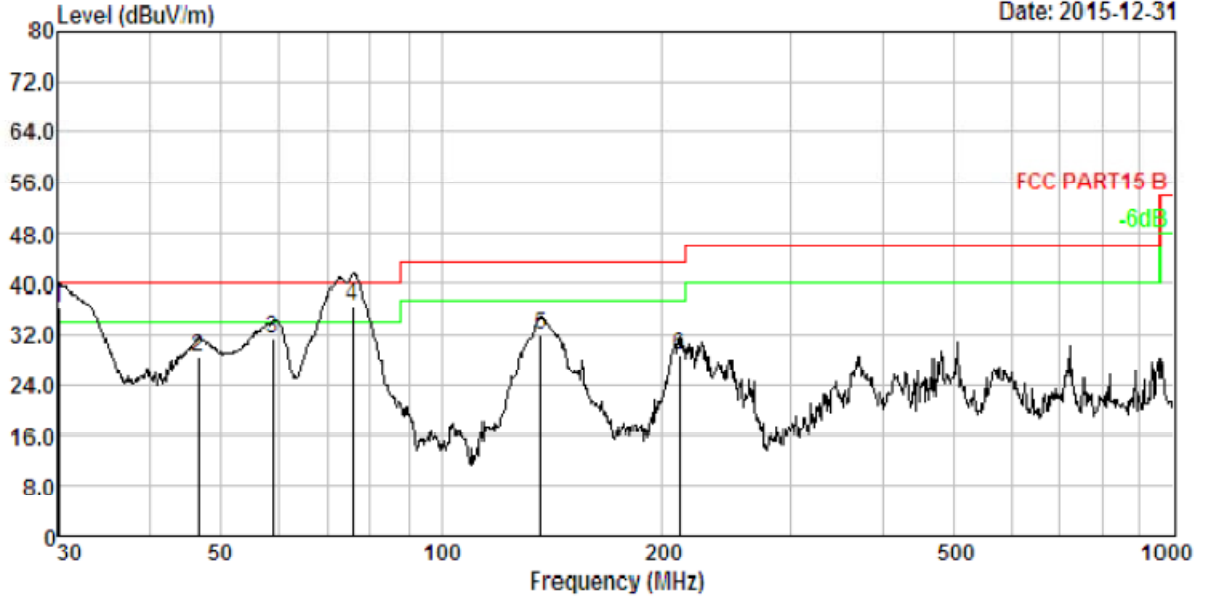

No.	Freq MHz	Cable Loss dB	ANT Factor dB/m	Receiver Reading dBuV	Preamp Factor dB	Emission Level dBuV/m	Limit dBuV/m	Over Limit dB	Remark
1.	30.000	1.06	13.24	51.86	29.97	36.19	40.00	-3.81	QP
2.	46.503	1.45	12.94	44.21	30.12	28.48	40.00	-11.52	QP
3.	58.819	1.66	12.11	47.71	30.20	31.28	40.00	-8.72	QP
4.	75.711	1.89	9.71	55.24	30.29	36.55	40.00	-3.45	QP
5.	136.939	2.43	13.14	46.76	30.50	31.83	43.50	-11.67	QP
6.	211.527	2.82	10.60	45.90	30.65	28.67	43.50	-14.83	QP



Antenna Polarization: Horizontal

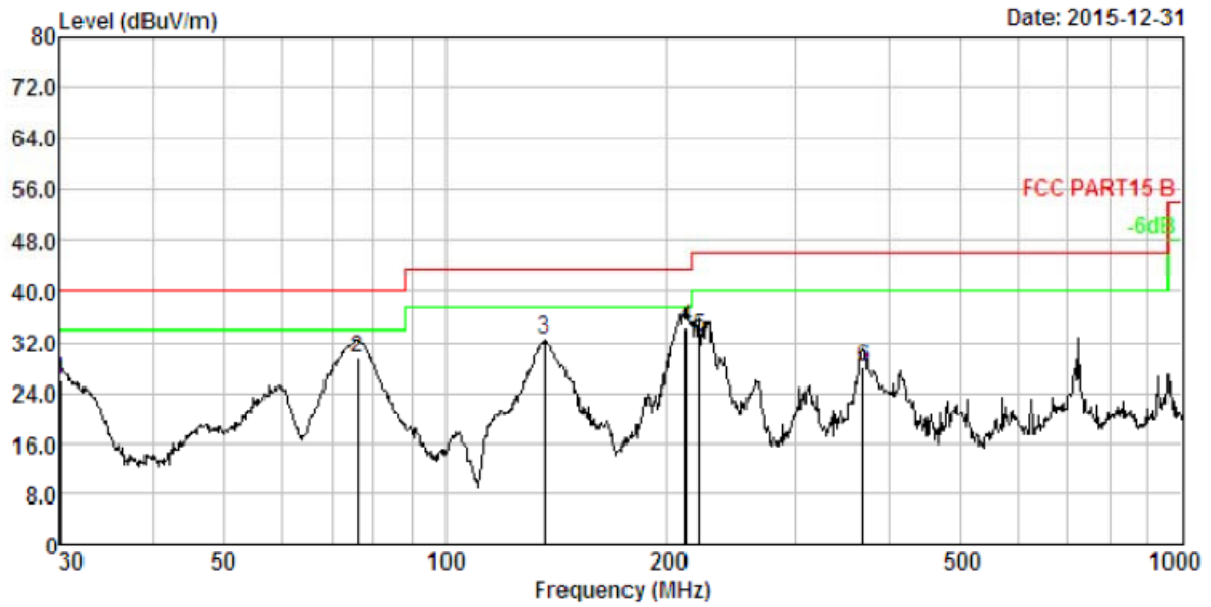

No.	Freq MHz	Cable Loss dB	ANT Factor dB/m	Receiver Reading dBuV	Preamp Factor dB	Emission Level dBuV/m	Limit dBuV/m	Over Limit dB	Remark
1.	30.000	1.06	13.24	41.55	29.97	25.88	40.00	-14.12	QP
2.	75.977	1.90	9.65	48.19	30.29	29.45	40.00	-10.55	QP
3.	136.460	2.43	13.11	47.29	30.50	32.33	43.50	-11.17	QP
4.	212.270	2.83	10.62	51.36	30.65	34.16	43.50	-9.34	QP
5.	221.392	2.86	10.83	49.73	30.67	32.75	46.00	-13.25	QP
6.	369.405	3.33	14.62	40.81	30.84	27.92	46.00	-18.08	QP

Test Frequency: Above 1GHz

Frequency (MHz)	Meter Reading (dB μ V)	Factor (dB)	Emission Level (dB μ V/m)	Limits (dB μ V/m)	Margin (dB)	Detector Type	Comment
1724.41	56.30	-16.36	39.94	74.00	-34.06	peak	Vertical
2639.16	54.64	-12.17	42.47	74.00	-31.53	peak	Vertical
3682.24	55.49	-8.69	46.80	74.00	-27.20	peak	Vertical
4415.14	50.81	-5.42	45.39	74.00	-28.61	peak	Vertical
1473.80	54.62	-17.14	37.48	74.00	-36.52	peak	Horizontal
2646.65	56.48	-14.73	41.75	74.00	-32.25	peak	Horizontal
4174.45	50.26	-5.67	44.59	74.00	-29.41	peak	Horizontal
5037.36	50.79	-3.82	46.97	74.00	-27.03	peak	Horizontal

Remark: Factor = Antenna Factor + Cable Loss – Pre-amplifier.



7 Test Setup

Radiated Emission
From 30MHz-1000MHz

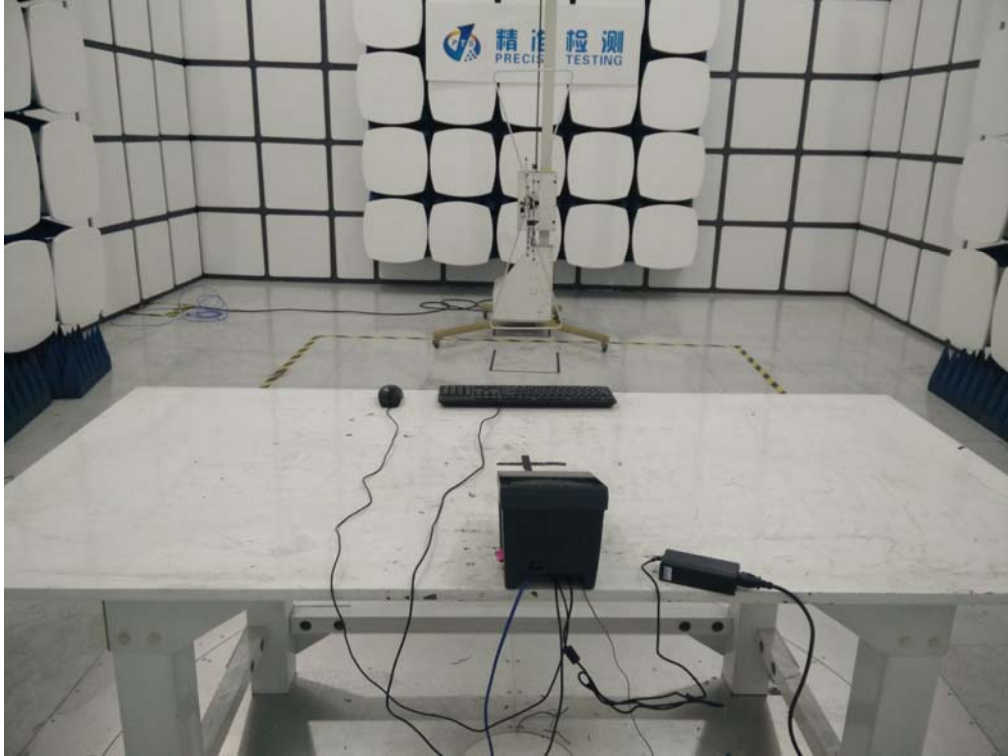

Above 1GHz

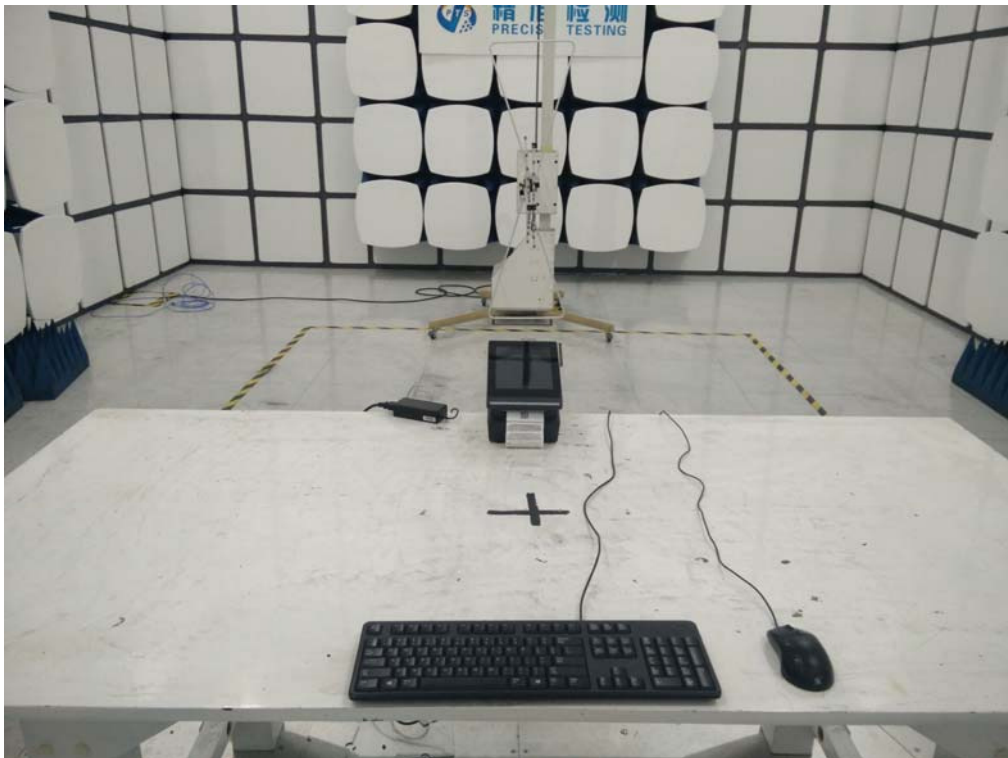

Conducted Emissions



***** THE END REPORT*****