

FCC SAR Test Report

FCC ID:2AG5OPB-711-B

Report No. : BTL-FCC SAR-1-2007T023B
Equipment : Pebblebee Found
Model Name : PB-711-B
Brand Name : Found
Applicant : PB Inc.
Address : PO Box 2962 Renton Washington United States 98056
Manufacturer : Goldtek Technology Co., Ltd.
Address : 16F., No.166, Jian 1st Rd., Zhonghe Dist., New Taipei City 235, Taiwan (R.O.C.)
Radio Function : BT 5.0, CatM1 B2, B4, B12

Standard(s) : **ANSI Std C95.1:2019** Safety Levels with Respect to Human Exposure to Radio Frequency Electromagnetic Fields, 3 kHz – 300 GHz.(IEEE Std C95.1-2019)
IEEE Std 1528:2013 Recommended Practice for Determining the Peak Spatial-Average Specific Absorption Rate (SAR) in the Human Head from Wireless Communications Devices: Measurement Techniques
KDB941225 D05 SAR for LTE Devices v02r05
KDB941225 D07 UMPC Mini Tablet
KDB447498 D01 General RF Exposure Guidance v07
KDB248227 D01 802.11 Wi-Fi SAR v02r02
KDB865664 D01 SAR measurement 100 MHz to 6 GHz v01r04
KDB865664 D02 SAR Reporting v01r02
KDB690783 D01 SAR Listings on Grants v01r03

Date of Receipt : 2021/11/10
Date of Test : 2020/7/10 ~ 2021/12/7
Issued Date : 2021/12/10

The above equipment has been tested and found in compliance with the requirement of the above standards by BTL Inc.

Prepared by :

Jerry Chuang, Supervisor



Approved by :

Peter Chen, Assistant Manager

BTL Inc.

No.18, Ln. 171, Sec. 2, Jiuzong Rd., Neihu Dist., Taipei City 114, Taiwan

Tel: +886-2-2657-3299

Fax: +886-2-2657-3331

Web: www.newbtl.com

Declaration

BTL represents to the client that testing is done in accordance with standard procedures as applicable and that test instruments used has been calibrated with standards traceable to international standard(s) and/or national standard(s).

BTL's reports apply only to the specific samples tested under conditions. It is manufacture's responsibility to ensure that additional production units of this model are manufactured with the identical electrical and mechanical components. **BTL** shall have no liability for any declarations, inferences or generalizations drawn by the client or others from **BTL** issued reports.

This report is the confidential property of the client. As a mutual protection to the clients, the public and ourselves, the test report shall not be reproduced, except in full, without our written approval.

BTL's laboratory quality assurance procedures are in compliance with the **ISO/IEC 17025** requirements, and accredited by the conformity assessment authorities listed in this test report.

BTL is not responsible for the sampling stage, so the results only apply to the sample as received.

The information, data and test plan are provided by manufacturer which may affect the validity of results, so it is manufacturer's responsibility to ensure that the apparatus meets the essential requirements of applied standards and in all the possible configurations as representative of its intended use.

Limitation

For the use of the authority's logo is limited unless the Test Standard(s)/Scope(s)/Item(s) mentioned in this test report is (are) included in the conformity assessment authorities acceptance respective.

Please note that the measurement uncertainty is provided for informational purpose only and are not use in determining the Pass/Fail results.

Table of Contents	Page
1. GENERAL INFORMATION	6
1.1. GENERAL DESCRIPTION OF EUT	6
2. SUMMARY OF SAR MEASUREMENT	7
2.1. TEST FACILITY	7
2.2. MEASUREMENT UNCERTAINTY	7
2.3. ANTENNA INFORMATION:	9
2.4. THE MAXIMUM SAR 1G VALUES	9
2.5. LABORATORY ENVIRONMENT	9
2.6. MAIN TEST INSTRUMENTS	10
3. SAR MEASUREMENTS SYSTEM CONFIGURATION	11
3.1. SAR MEASUREMENT SETUP	11
3.1.1. TEST SETUP LAYOUT	11
3.2. DASY5 E-FIELD PROBE SYSTEM	12
3.2.1. EX3DV4 PROBE SPECIFICATION	12
3.2.2. E-FIELD PROBE CALIBRATION	13
3.2.3. OTHER TEST EQUIPMENT	14
3.2.4. SCANNING PROCEDURE	15
3.2.5. DATA STORAGE AND EVALUATION	16
3.2.6. DATA EVALUATION BY SEMCAD	17
4. TISSUE-EQUIVALENT LIQUID	19
4.1. TISSUE-EQUIVALENT LIQUID INGREDIENTS	19
4.2. TISSUE-EQUIVALENT LIQUID PROPERTIES	19
5. SYSTEM CHECK	20
5.1. DESCRIPTION OF SYSTEM CHECK	20
5.2. DESCRIPTION OF SYSTEM CHECK	21
6. OPERATIONAL CONDITIONS DURING TEST	22
6.1. GENERAL DESCRIPTION OF TEST PROCEDURES	22
6.2. TEST POSITION OF PORTABLE DEVICES	22
6.3. TEST POSITION OF PORTABLE DEVICES	22
6.4. TEST POSITION	23
6.4.1. BODY TEST CONFIGURATION	23
6.5. SAR EXCLUSION CALCULATIONS FOR ANTENNA	24
7. CONDUCTED POWER RESULTS	25
7.1. CONDUCTED POWER MEASUREMENTS OF UHF	25
7.2. CONDUCTED POWER MEASUREMENT RESULTS OF BLUETOOTH	27
8. SAR TEST RESULTS	28
8.1. BODY SAR TEST RESULTS	28
9. MULTIPLE TRANSMITTER EVALUATION	29
9.1. STAND-ALONE SAR TEST EXCLUSION	29

Table of Contents	Page
9.2. ESTIMATED SAR FOR SIMULTANEOUS TRANSMISSION SAR ANALYSIS	29
9.2.1 ESTIMATED SAR FOR BLUETOOTH	29
9.3. SIMULTANEOUS TRANSMISSION CONDITIONS	30
10. TEST LAYOUT	31

REPORT ISSUED HISTORY

Report Version	Description	Issued Date
R00	Original Issue.	2021/12/10

1 GENERAL INFORMATION

1.1 GENERAL DESCRIPTION OF EUT

Equipment	Pebblebee Found		
Model Name	PB-711-B		
Operation Frequency Range(s)	Band	TX (MHz)	RX (MHz)
	LTE Cat-M1 B2		1850 - 1910
	LTE Cat-M1 B4		1710 - 1755
	LTE Cat-M1 B12		699 - 716
	BLE		2400 - 2500

The above equipment has been tested and found compliance with the requirement of the relative standards by BTL Inc.

The test data, data evaluation, and equipment configuration contained in our test report (Ref No. BTL-FCC-SAR-1-2007T023) were obtained utilizing the test procedures, test instruments, test sites that has been accredited by the Authority of TAF according to the ISO-17025 quality assessment standard and technical standard(s).

2 SUMMARY OF SAR MEASUREMENT

2.1 TEST FACILITY

The test facilities used to collect the test data in this report is **SAR Test room** at the location of No. 68-1, Ln. 169, Sec.2, Datong Rd., Xizhi Dist., New Taipei City 221, Taiwan.

2.2 MEASUREMENT UNCERTAINTY

Uncertainty Budget for Frequency range of 300 MHz to 3 GHz

Error Description	Uncertainty Value (\pm %)		Probability Distribution	Divisor	Ci (1g)	Ci (10g)	Standard Uncertainty (1g)	Standard Uncertainty (10g)	Vi V _{ef} _f
Measurement System									
Probe Calibration	6.05		Normal	1	1	1	± 6.05 %	± 6.05 %	∞
Axial Isotropy	4.7		Rectangular	$\sqrt{3}$	0.7	0.7	± 1.9 %	± 1.9 %	∞
Hemispherical Isotropy	9.6		Rectangular	$\sqrt{3}$	0.7	0.7	± 3.9 %	± 3.9 %	∞
Boundary Effects	1		Rectangular	$\sqrt{3}$	1	1	± 0.6 %	± 0.6 %	∞
Linearity	4.7		Rectangular	$\sqrt{3}$	1	1	± 2.7 %	± 2.7 %	∞
Detection Limits	1		Rectangular	$\sqrt{3}$	1	1	± 0.6 %	± 0.6 %	∞
Modulation response	2.4		Rectangular	$\sqrt{3}$	1	1	± 1.4 %	± 1.4 %	∞
Readout Electronics	0.3		Normal	1	1	1	± 0.3 %	± 0.3 %	∞
Response Time	0.8		Rectangular	$\sqrt{3}$	1	1	± 0.5 %	± 0.5 %	∞
Integration Time	2.6		Rectangular	$\sqrt{3}$	1	1	± 1.5 %	± 1.5 %	∞
RF Ambient – Noise	3		Rectangular	$\sqrt{3}$	1	1	± 1.7 %	± 1.7 %	∞
RF Ambient– Reflections	3		Rectangular	$\sqrt{3}$	1	1	± 1.7 %	± 1.7 %	∞
Probe Positioner	0.4		Rectangular	$\sqrt{3}$	1	1	± 0.2 %	± 0.2 %	∞
Probe Positioning	2.9		Rectangular	$\sqrt{3}$	1	1	± 1.7 %	± 1.7 %	∞
Post-processing	4		Rectangular	$\sqrt{3}$	1	1	± 2.3 %	± 2.3 %	∞
Max.SAR Evaluation	2		Rectangular	$\sqrt{3}$	1	1	± 1.15 %	± 1.15 %	∞
Test Sample Related									
Device Positioning	1.6	1.8	Normal	1	1	1	± 1.6 %	± 1.8 %	145
Device Holder	1.5	1.7	Normal	1	1	1	± 1.5 %	± 1.7 %	5
Power Drift	5.0		Rectangular	$\sqrt{3}$	1	1	± 2.9 %	± 2.9 %	∞
Phantom and Setup									
Phantom Production Tolerances	6.1		Rectangular	$\sqrt{3}$	1	1	3.52	3.52	∞
SAR correction	1.9		Rectangular	$\sqrt{3}$	1	0.84	1.10	1.10	
Liquid Conductivity (mea.)	2.4		Rectangular	$\sqrt{3}$	0.78	0.71	1.08	1.08	∞
Liquid Permittivity (mea.)	2.4		Rectangular	$\sqrt{3}$	0.26	0.26	0.36	0.36	∞
Temp. unc. - Conductivity	3.4		Rectangular	$\sqrt{3}$	0.78	0.71	1.53	1.53	∞
Temp. unc. - Permittivity	0.4		Rectangular	$\sqrt{3}$	0.23	0.26	0.05	0.05	∞
Combined Standard Uncertainty (K = 1)							± 10.42 %	± 10.48 %	361
Expanded Uncertainty (K = 2)							± 20.84 %	± 20.97 %	

Uncertainty Budget for Frequency range of 3 GHz to 6 GHz

Error Description	Uncertainty Value (± %)		Probability Distribution	Divisor	Ci (1g)	Ci (10g)	Standard Uncertainty (1g)	Standard Uncertainty (10g)	Vi V _{eff}
Measurement System									
Probe Calibration	6.65		Normal	1	1	1	± 6.65 %	± 6.65 %	∞
Axial Isotropy	4.7		Rectangular	$\sqrt{3}$	0.7	0.7	± 1.9 %	± 1.9 %	∞
Hemispherical Isotropy	9.6		Rectangular	$\sqrt{3}$	0.7	0.7	± 3.9 %	± 3.9 %	∞
Boundary Effects	2		Rectangular	$\sqrt{3}$	1	1	± 1.2 %	± 1.2 %	∞
Linearity	4.7		Rectangular	$\sqrt{3}$	1	1	± 2.7 %	± 2.7 %	∞
Detection Limits	1		Rectangular	$\sqrt{3}$	1	1	± 0.6 %	± 0.6 %	∞
Modulation response	2.4		Rectangular	$\sqrt{3}$	1	1	± 1.4 %	± 1.4 %	∞
Readout Electronics	0.3		Normal	1	1	1	± 0.3 %	± 0.3 %	∞
Response Time	0.8		Rectangular	$\sqrt{3}$	1	1	± 0.5 %	± 0.5 %	∞
Integration Time	2.6		Rectangular	$\sqrt{3}$	1	1	± 1.5 %	± 1.5 %	∞
RF Ambient – Noise	3		Rectangular	$\sqrt{3}$	1	1	± 1.7 %	± 1.7 %	∞
RF Ambient– Reflections	3		Rectangular	$\sqrt{3}$	1	1	± 1.7 %	± 1.7 %	∞
Probe Positioner	0.4		Rectangular	$\sqrt{3}$	1	1	± 0.2 %	± 0.2 %	∞
Probe Positioning	6.7		Rectangular	$\sqrt{3}$	1	1	± 3.9 %	± 3.9 %	∞
Post-processing	4		Rectangular	$\sqrt{3}$	1	1	± 2.3 %	± 2.3 %	∞
Max.SAR Evaluation	4		Rectangular	$\sqrt{3}$	1	1	± 2.3 %	± 2.3 %	∞
Test Sample Related									
Device Positioning	1.6	1.8	Normal	1	1	1	± 1.6 %	± 1.8 %	145
Device Holder	1.5	1.7	Normal	1	1	1	± 1.5 %	± 1.7 %	5
Power Drift	5.0		Rectangular	$\sqrt{3}$	1	1	± 2.9 %	± 2.9 %	∞
Phantom and Setup									
Phantom Production Tolerances	6.6		Rectangular	$\sqrt{3}$	1	1	3.81	3.81	∞
SAR correction	1.9		Rectangular	$\sqrt{3}$	1	0.84	1.10	0.92	
Liquid Conductivity (mea.)	2.4		Rectangular	$\sqrt{3}$	0.78	0.71	1.08	0.98	∞
Liquid Permittivity (mea.)	2.4		Rectangular	$\sqrt{3}$	0.26	0.26	0.36	0.36	∞
Temp. unc. - Conductivity	3.4		Rectangular	$\sqrt{3}$	0.78	0.71	1.53	1.39	∞
Temp. unc. - Permittivity	0.4		Rectangular	$\sqrt{3}$	0.23	0.26	0.05	0.06	∞
Combined Standard Uncertainty (K = 1)							± 11.65 %	± 11.66 %	361
Expanded Uncertainty (K = 2)							± 23.29 %	± 23.33 %	

2.3. Antenna Information:

Antenna Information				
Brand	Model	Antenna type	Band	Gain(dBi)
Wieson	ARY197-1757-003-00	PIFA	Cat-M1 Band 2	-4.37
			Cat-M1 Band 4	-6.53
			Cat-M1 Band 12	-8.46
			BLE	-2.57

2.4. The Maximum SAR 1g Values

Equipment Class	Mode	Highest Body SAR-1g (W/kg)
PCE	LTE Cat-M1 B2	0.413
	LTE Cat-M1 B4	0.223
	LTE Cat-M1 B12	0.279
Bluetooth	BLE	0.145

Note:

1.The device is in compliance with Specific Absorption Rate(SAR)for general population uncontrolled exposure limits according to the FCC rule §2.1093, the ANSI C95.1:2019/IEEE C95.1:2019, the NCRP Report Number 86 for uncontrolled environment and had been tested in accordance with the measurement methods and procedures specified in IEEE Std 1528-2013 .

2.5. Laboratory Environment

Temperature	Min. = 18°C, Max. = 25°C
Relative humidity	Min. = 30%, Max. = 70%
Ground system resistance	< 0.5Ω
Ambient noise is checked and found very low and in compliance with requirement of standards. Reflection of surrounding objects is minimized and in compliance with requirement of standards.	

2.6. Main Test Instruments

Item	Equipment	Manufacturer	Model	Serial No.	Cal. Date	Cal. Interval
1	Data Acquisition Electronics	Speag	DAE4	1486	Jun. 04, 2020	1 Year
2	Data Acquisition Electronics	Speag	DAE4	1486	Jun. 01, 2021	1 Year
3	E-field Probe	Speag	EX3DV4	7369	May. 29, 2020	1 Year
4	E-field Probe	Speag	EX3DV4	7369	Jun. 3, 2021	1 Year
5	System Validation Dipole	Speag	D750V3	1145	Jun. 12, 2019	3 Year
6	System Validation Dipole	Speag	D1750V2	1101	Jun. 7, 2018	3 Year
7	System Validation Dipole	Speag	D1900V2	5d208	Jun. 11, 2019	3 Year
8	System Validation Dipole	Speag	D2450V2	973	Feb. 08, 2021	3 Year
9	ELI4 Phantom	Speag	ELI4 Phantom V5.0	1240	N/A	N/A
10	ENA Network Analyzer	Agilent	E5071C	MY46524658	Apr. 07, 2020	1 Year
11	ENA Network Analyzer	Agilent	E5071C	MY46524658	Mar. 17, 2021	1 Year
12	EXA Spectrum Analyzer	Keysight	N9010A	MY54200240	Jul. 25, 2019	1 Year
13	EXA Spectrum Analyzer	Keysight	N9010A	MY54200240	May. 27, 2021	1 Year
14	Power Meter	Anritsu	ML2487A	6K00004714	Jun. 20, 2019	1 Year
15	Power Meter	Anritsu	ML2495A	1128008	May. 26, 2021	1 Year
16	Power Sensor	Anritsu	MA2491A	1725282	Jun. 20, 2019	1 Year
17	Power Sensor	Anritsu	MA2411B	1126001	May. 26, 2021	1 Year
18	Dielectric Probe Kit	Agilent	85070E	2593	N/A	N/A
19	Low pass filter	Mini-Circuits	SLP-2950+	M108294	N/A	N/A
20	Power Amplifier	Mini-Circuits	ZVE-2W-272+	N650001538	N/A	N/A
21	Power Amplifier	Mini-Circuits	ZVE-8G+	N628801631	N/A	N/A

Remark: "N/A" denotes no model name, serial No. or calibration specified.

3 SAR MEASUREMENTS SYSTEM CONFIGURATION

3.1 SAR Measurement Setup

The DASY5 system for performing compliance tests consists of the following items:

1. A standard high precision 6-axis robot (Stäubli RX family) with controller and software. An arm extension for accommodating the data acquisition electronics (DAE).
2. A dosimetric probe, i.e. an isotropic E-field probe optimized and calibrated for usage in tissue simulating liquid. The probe is equipped with an optical surface detector system.
3. A data acquisition electronic (DAE) which performs the signal amplification, signal multiplexing, AD-conversion, offset measurements, mechanical surface detection, collision detection, etc. The unit is battery powered with standard or rechargeable batteries. The signal is optically transmitted to the EOC.
4. A unit to operate the optical surface detector which is connected to the EOC.
5. The Electro-Optical Coupler (EOC) performs the conversion from the optical into a digital electric signal of the DAE. The EOC is connected to the DASY5 measurement server.
6. The DASY5 measurement server, which performs all real-time data evaluation for field measurements and surface detection, controls robot movements and handles safety operation. A computer operating Windows.
7. DASY5 software and SEMCAD data evaluation software.
8. Remote control with teach panel and additional circuitry for robot safety such as warning lamps, etc.
9. The generic twin phantom enabling the testing of left-hand and right-hand usage.
10. The device holder for handheld mobile phones.
11. Tissue simulating liquid mixed according to the given recipes.
12. System validation dipoles allowing to validate the proper functioning of the system.

3.1.1 TEST SETUP LAYOUT

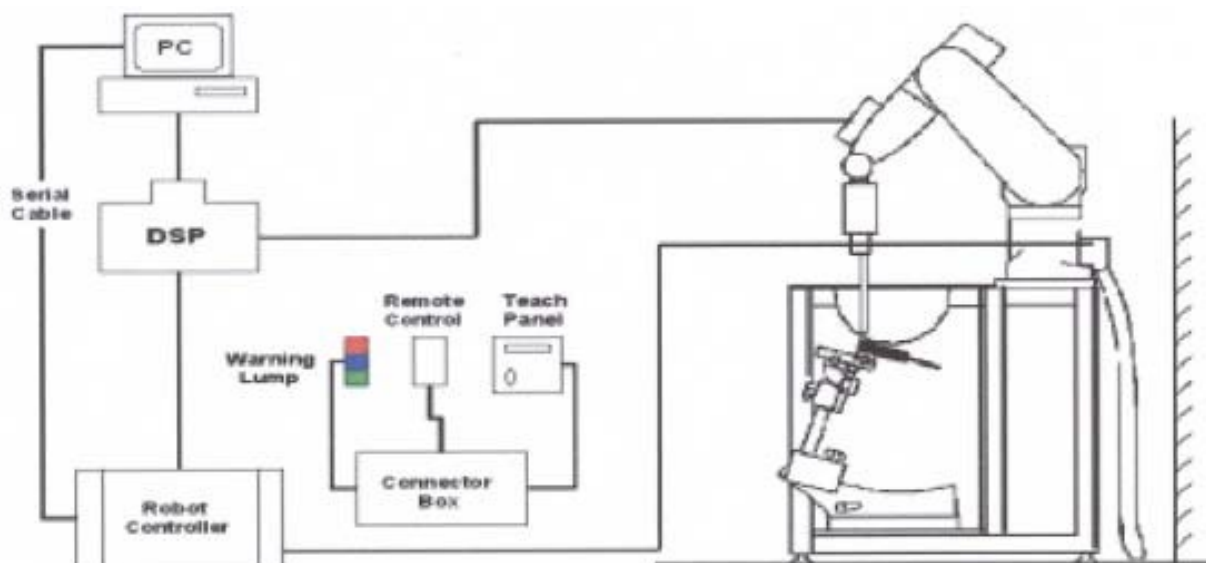

3.2 DASY5 E-field Probe System

The SAR measurements were conducted with the dosimetric probe EX3DV4 (manufactured by SPEAG), designed in the classical triangular configuration and optimized for dosimetric evaluation.

3.2.1 EX3DV4 PROBE SPECIFICATION

Construction	Symmetrical design with triangular core Interleaved sensors Built-in shielding against static charges PEEK enclosure material (resistant to organic solvents, e.g., DGBE)
Calibration	ISO/IEC 17025 calibration service available
Frequency	10 MHz to 6 GHz Linearity: ± 0.2 dB (30 MHz to 6 GHz)
Directivity	± 0.3 dB in HSL (rotation around probe axis) ± 0.5 dB in tissue material (rotation normal to probe axis)
Dynamic Range	10 μ W/g to > 100 mW/g Linearity: ± 0.2 dB
Dimensions	Overall length: 330 mm (Tip: 20 mm) Tip diameter: 2.5 mm (Body: 12 mm) Distance from probe tip to dipole centers: 1.0 mm

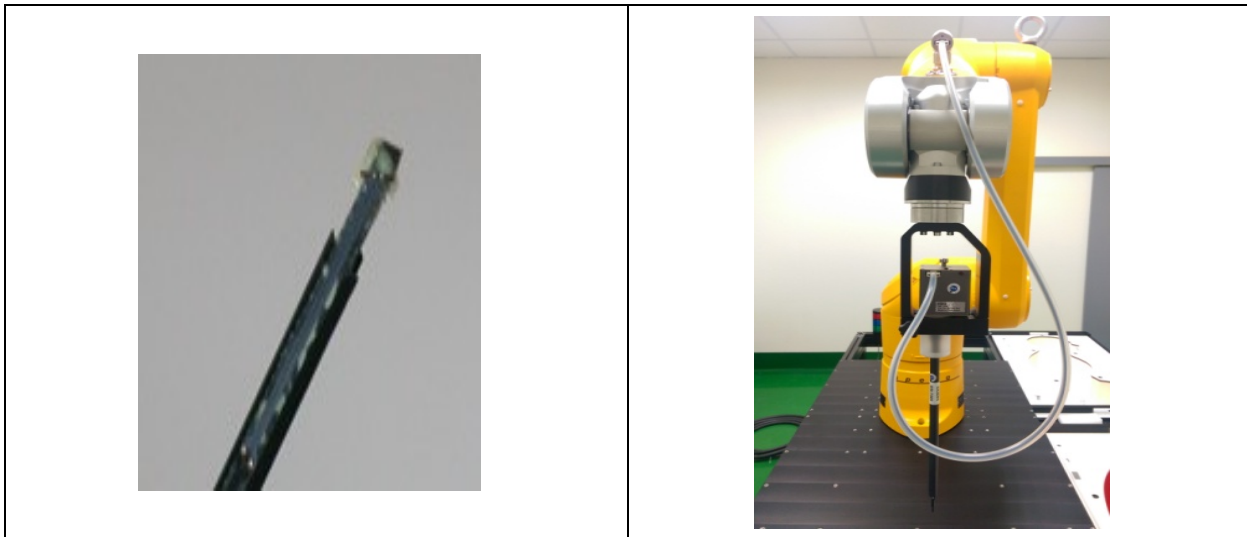

EX3DV4 E-field Probe

3.2.2 E-FIELD PROBE CALIBRATION

Each probe is calibrated according to a dosimetric assessment procedure with accuracy better than $\pm 10\%$. The spherical isotropy was evaluated and found to be better than $\pm 0.25\text{dB}$. The sensitivity parameters (NormX, NormY, NormZ), the diode compression parameter (DCP) and the conversion factor (ConvF) of the probe are tested.

The free space E-field from amplified probe outputs is determined in a test chamber. This is performed in a TEM cell for frequencies below 1 GHz, and in a wave guide above 1 GHz for free space. For the free space calibration, the probe is placed in the volumetric center of the cavity and at the proper orientation with the field. The probe is then rotated 360 degrees.

E-field temperature correlation calibration is performed in a flat phantom filled with the appropriate simulated brain tissue. The measured free space E-field in the medium correlates to temperature rise in a dielectric medium. For temperature correlation calibration a RF transparent thermistor-based temperature probe is used in conjunction with the E-field probe.

$$\text{SAR} = C \frac{\Delta T}{\Delta t}$$

Where: Δt = Exposure time (30 seconds),

C = Heat capacity of tissue (brain or muscle),

ΔT = Temperature increase due to RF exposure.

Or
$$\text{SAR} = \frac{|E|^2 \sigma}{\rho}$$

Where: σ = Simulated tissue conductivity,

ρ = Tissue density (kg/m³).

3.2.3 OTHER TEST EQUIPMENT

3.2.3.1. DEVICE HOLDER FOR TRANSMITTERS

Construction: Simple but effective and easy-to-use extension for Mounting Device that facilitates the testing of larger devices according to IEC 62209-2 (e.g., laptops, cameras, etc.) It is lightweight and fits easily on the upper part of the Mounting Device in place of the phone positioner. The extension is fully compatible with the Twin SAM, ELI4 and SAM v6.0 Phantoms.

Material: POM, Acrylic glass, Foam

3.2.3.2 PHANTOM

Model	ELI4 Phantom	
Construction	Phantom for compliance testing of handheld and body-mounted wireless devices in the frequency range of 30 MHz to 6 GHz. ELI is fully compatible with the IEC 62209-2 standard and all known tissue simulating liquids. ELI has been optimized regarding its performance and can be integrated into our standard phantom tables. A cover prevents evaporation of the liquid. Reference markings on the phantom allow installation of the complete setup, including all predefined phantom positions and measurement grids, by teaching three points. The phantom is compatible with all SPEAG dosimetric probes and dipoles.	
Shell Thickness	2±0.1 mm	
Filling Volume	Approx. 30 liters	
Dimensions	Length: 600 mm ; Width: 190mm Height: adjustable feet	
Available	Special	

Model	Twin SAM	
Construction	The shell corresponds to the specifications of the Specific Anthropomorphic Mannequin (SAM) phantom defined in IEEE 1528 and IEC 62209-1. It enables the dosimetric evaluation of left and right hand phone usage as well as body mounted usage at the flat phantom region. A cover prevents evaporation of the liquid. Reference markings on the phantom allow the complete setup of all predefined phantom positions and measurement grids by teaching three points with the robot.	
Shell Thickness	2 ± 0.2 mm	
Filling Volume	Approx. 25 liters	
Dimensions	Length:1000mm; Width: 500mm Height: adjustable feet	
Available	Special	

3.2.4 SCANNING PROCEDURE

The SAR test against the head and body-worn phantom was carried out as follow:

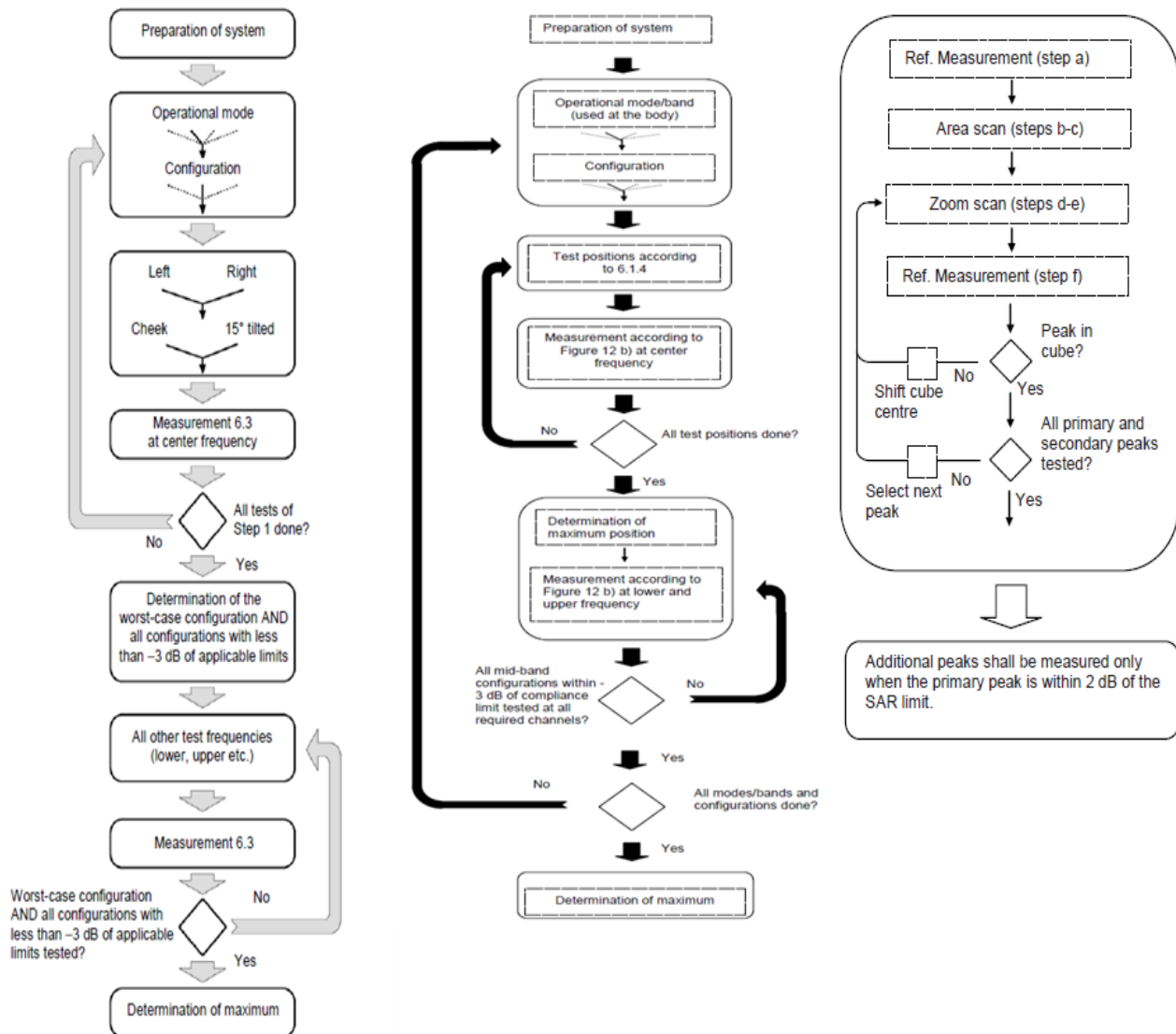

After an area scan has been done at a fixed distance of 1.4mm from the surface of the phantom on the source side, a 3D scan is set up around the location of the maximum spot SAR. First, a point within the scan area is visited by the probe and a SAR reading taken at the start of testing. At the end of testing, the probe is returned to the same point and a second reading is taken. Comparison between these start and end readings enables the power drift during measurement to be assessed.

Above is the scanning procedure flow chart and table from the IEEE1528 standard.

This is the procedure for which all compliant testing should be carried out to ensure that all variations of the device position and transmission behavior are tested.

3.2.5 DATA STORAGE AND EVALUATION

3.2.5.1 DATA STORAGE

The DASY5 software stores the acquired data from the data acquisition electronics as raw data (in microvolt readings from the probe sensors), together with all necessary software parameters for the data evaluation (probe calibration data, liquid parameters and device frequency and modulation data) in measurement files with the extension "DAE4". The software evaluates the desired unit and format for output each time the data is visualized or exported. This allows verification of the complete software setup even after the measurement and allows correction of incorrect parameter settings. For example, if a measurement has been performed with a wrong crest factor parameter in the device setup, the parameter can be corrected afterwards and the data can be re-evaluated.

The measured data can be visualized or exported in different units or formats, depending on the selected probe type ([V/m], [A/m], [°C], [mW/g], [mW/cm²], [dBrel], etc.). Some of these units are not available in certain situations or show meaningless results, e.g., a SAR output in a lossless media will always be zero. Raw data can also be exported to perform the evaluation with other software packages.

3.2.6 DATA EVALUATION BY SEMCAD

The SEMCAD software automatically executes the following procedures to calculate the field units from the microvolt readings at the probe connector. The parameters used in the evaluation are stored in the configuration modules of the software:

Probe parameters:	Sensitivity	Normi, a _{i0} , a _{i1} , a _{i2}
	Conversion factor	ConvF _i
	Diode compression point	Dcp _i
Device parameters:	Frequency	f
	Crest factor	cf
Media parameters:	Conductivity	
	Density	

These parameters must be set correctly in the software. They can be found in the component documents or they can be imported into the software from the configuration files issued for the DASY5 components. In the direct measuring mode of the multimeter option, the parameters of the actual system setup are used. In the scan visualization and export modes, the parameters stored in the corresponding document files are used.

The first step of the evaluation is a linearization of the filtered input signal to account for the compression characteristics of the detector diode. The compensation depends on the input signal, the diode type and the DC-transmission factor from the diode to the evaluation electronics.

If the exciting field is pulsed, the crest factor of the signal must be known to correctly compensate for peak power. The formula for each channel can be given as:

$$V_i = U_i + U_i^2 \cdot cf / dcp_i$$

With	V _i = compensated signal of channel i	(i = x, y, z)
	U _i = input signal of channel i	(i = x, y, z)
	cf = crest factor of exciting field	(DASY parameter)
	dcp _i = diode compression point	(DASY parameter)

From the compensated input signals the primary field data for each channel can be evaluated:

$$\text{E-field probes: } E_i = (V_i / \text{Norm}_i \cdot \text{ConvF})^{1/2}$$

$$\text{H-field probes: } H_i = (V_i)^{1/2} \cdot (a_{i0} + a_{i1} f + a_{i2} f^2) / f$$

With V_i = compensated signal of channel i (i = x, y, z)

Norm_i = sensor sensitivity of channel i (i = x, y, z)
 [mV/(V/m)²] for E-field Probes

ConvF = sensitivity enhancement in solution

a_{ij} = sensor sensitivity factors for H-field probes

f = carrier frequency [GHz]

E_i = electric field strength of channel i in V/m

H_i = magnetic field strength of channel i in A/m

The RSS value of the field components gives the total field strength (Hermitian magnitude):

$$E_{\text{tot}} = (E_X^2 + E_Y^2 + E_Z^2)^{1/2}$$

The primary field data are used to calculate the derived field units.

$$\text{SAR} = (E_{\text{tot}})^2 \cdot \sigma / (\rho \cdot 1000)$$

With SAR = local specific absorption rate in mW/g

E_{tot} = total field strength in V/m
 = conductivity in [mho/m] or [Siemens/m]
 = equivalent tissue density in g/cm³

Note that the density is normally set to 1 (or 1.06), to account for actual brain density rather than the density of the simulation liquid. The power flow density is calculated assuming the excitation field to be a free space field.

$$P_{\text{pwe}} = E_{\text{tot}}^2 / 3770 \text{ or } P_{\text{pwe}} = H_{\text{tot}}^2 \cdot 37.7$$

With P_{pwe} = equivalent power density of a plane wave in mW/cm²

E_{tot} = total field strength in V/m

H_{tot} = total magnetic field strength in A/m

4 TISSUE-EQUIVALENT LIQUID

4.1 Tissue-equivalent Liquid Ingredients

The liquid is consisted of water, salt and Glycol, Sugar, Preventol and Cellulose. The liquid has previously been proven to be suited for worst-case. The measured conductivity and relative permittivity should be within $\pm 5\%$ of the target values. The below table shows the detail solution. It's satisfying the latest tissue dielectric parameters requirements proposed by the IEC 62209.

Composition of the Tissue Equivalent Matter

Tissue Type	Bactericide	DGBE	HEC	NaCl	Sucrose	Triton X-100	Water	Diethylene Glycol Mono-hexylether
Head 750	0.2	-	0.2	1.5	56.0	-	42.1	-
Head 1750	-	47.0	-	0.4	-	-	52.6	-
Head 1900	-	44.5	-	0.2	-	-	55.3	-
Head 2450	-	45.0	-	0.1	-	-	54.9	-

4.2 Tissue-equivalent Liquid Properties

Dielectric Performance of Tissue Simulating Liquid

Tissue Verification									
Date	Tissue Type	Frequency (MHz)	Conductivity (σ)	Permittivity (ϵ_r)	Targeted Conductivity (σ)	Targeted Permittivity (ϵ_r)	Deviation Conductivity (σ) (%)	Deviation Permittivity (ϵ_r) (%)	Limit (%) ± 5
2020/7/10	Head	750	0.91	42.58	0.89	41.94	1.86	1.52	± 5
2020/7/10	Head	1750	1.32	41.29	1.37	40.08	-3.72	3.02	± 5
2020/7/10	Head	1900	1.42	40.57	1.40	40.00	1.43	1.43	± 5
2021/12/7	Head	2450	1.82	38.44	1.80	39.20	1.11	-1.95	± 5

Note:

- 1) The dielectric parameters of the tissue-equivalent liquid should be measured under similar ambient conditions and within 2 °C of the conditions expected during the SAR evaluation to satisfy protocol requirements.
- 2) KDB 865664 was ensured to be applied for probe calibration frequencies greater than or equal to 50MHz of the EUT frequencies.
- 3) The above measured tissue parameters were used in the DASY software to perform interpolation via the DASY software to determine actual dielectric parameters at the test frequencies. The SAR test plots may slightly differ from the table above since the DASY rounds to three significant digits.
- 4) According to FCC TCB workshop April, 2019 RF Exposure Procedures Update (Effective February 19, 2019), FCC has permitted the use of single head-tissue simulating liquid specified in IEEE 62209-1- for all SAR tests.

5 SYSTEM CHECK

5.1 DESCRIPTION OF SYSTEM CHECK

The manufacturer calibrates the probes annually. Dielectric parameters of the tissue simulants were measured every day using the dielectric probe kit and the network analyzer. A system check measurement was made following the determination of the dielectric parameters of the simulant, using the dipole validation kit. A power level of 250 mW (below 3GHz) or 100mW (3-6GHz), which was placed under the flat section of the twin SAM phantom. The system check results (dielectric parameters and SAR values) are given in the 6.2.

System check results have to be equal or near the values determined during dipole calibration with the relevant liquids and test system ($\pm 10\%$).

System check is performed regularly on all frequency bands where tests are performed with the DASY5 system.

System Check Set-up

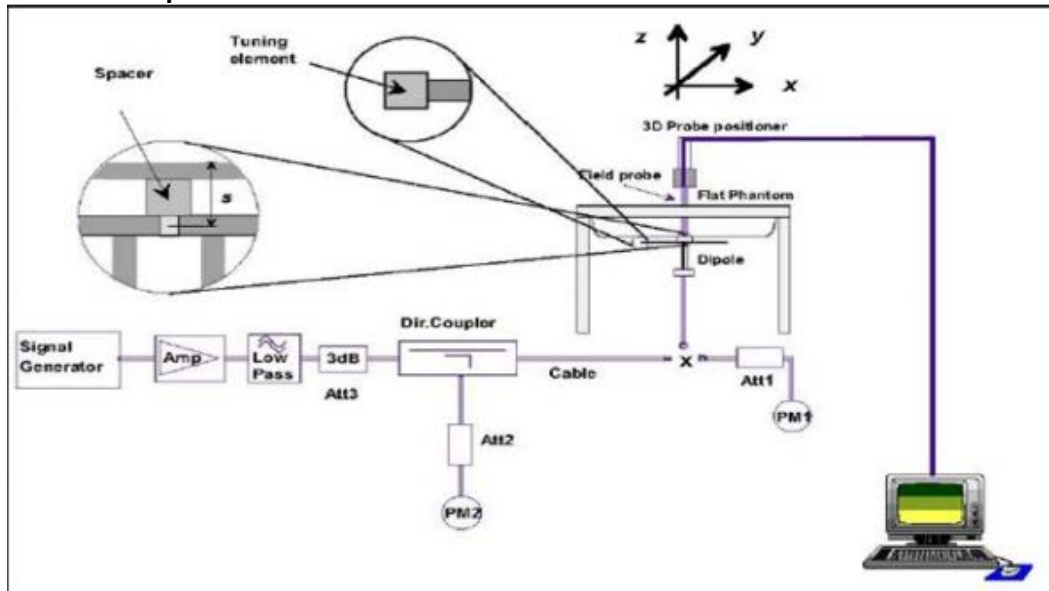

5.2 DESCRIPTION OF SYSTEM CHECK

System Check in Tissue Simulating Liquid

The system check is performed for verifying the accuracy of the complete measurement system and performance of the software. The system check is performed with tissue equivalent material according to IEEE P1528 (described above). The following table shows system check results for all frequency bands and tissue liquids used during the tests.

Date	System Dipole			Parameters	Target [W/kg]	Measured [W/kg]	Deviation [%]	Limited [%]
	Type	Serial No.	Liquid					
2020/7/10	D750V3	1145	Head	1g SAR	8.65	8.56	-1.04	± 10
2020/7/10	D1750V2	1101	Head	1g SAR	37.00	37.92	2.49	± 10
2020/7/10	D1900V2	5d208	Head	1g SAR	39.50	41.20	4.30	± 10
2021/12/7	D2450V2	973	Head	1g SAR	52.50	51.60	-1.71	± 10

6 OPERATIONAL CONDITIONS DURING TEST

6.1 General Description of Test Procedures

Connection to the EUT is established via air interface with base station An, and the EUT is Set to maximum output power by base station. The EUT battery must be fully charged and checked periodically during the test to ascertain uniform power output. The antenna connected to the output of the base station simulator shall be placed at least 50cm away from the EUT. The signal transmitted by the simulator to the antenna feeding point shall be lower than the output power level of the EUT by at least 30dB.

6.2 Test Position of Portable Devices

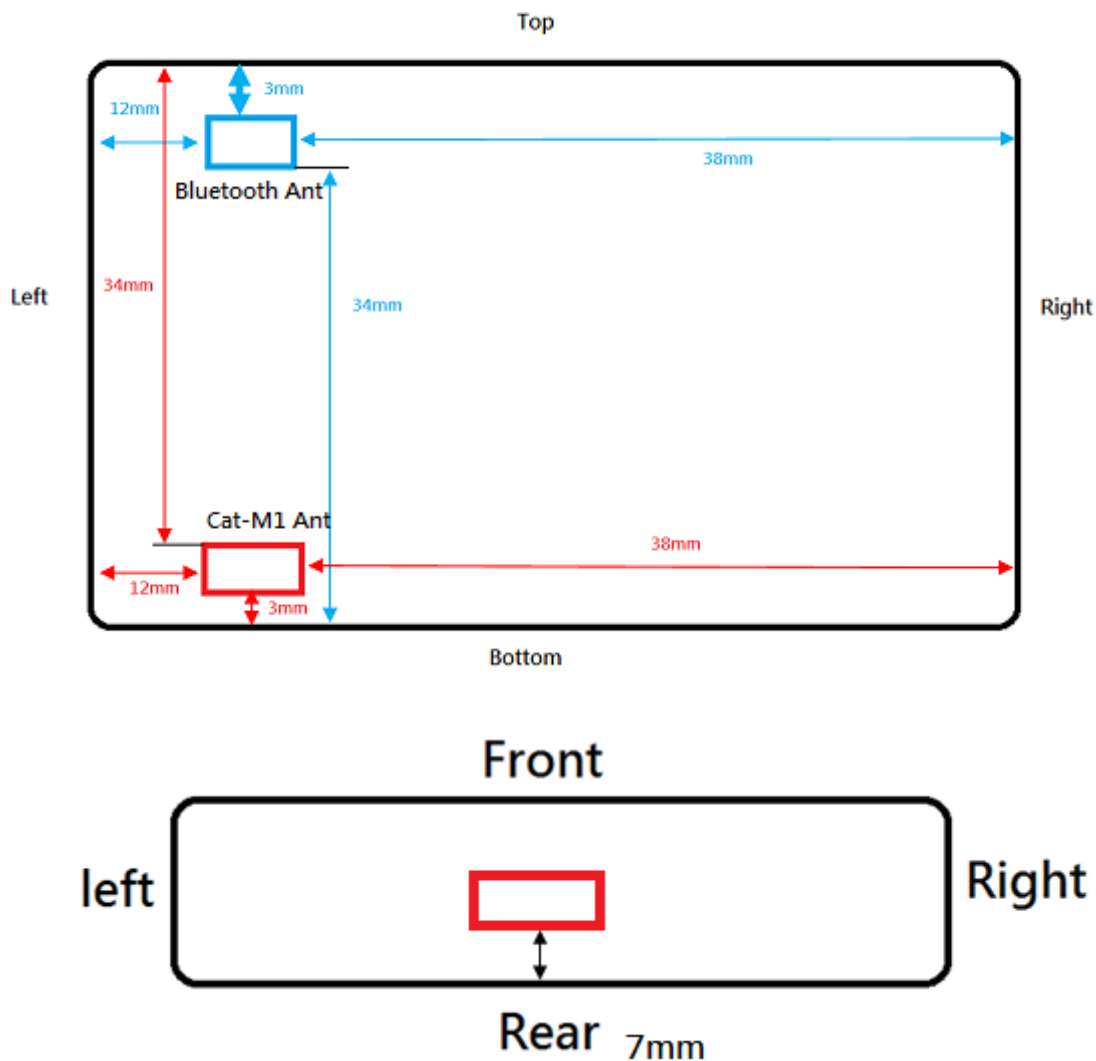

6.3 Test Position of Portable Devices

Antenna	Rear Face	Right Side	Left Side	Top Side	Bottom Side
Cat-M1	7mm	38mm	12mm	34mm	3mm
Bluetooth	7mm	38mm	12mm	3mm	34mm

6.4 Test position

6.4.1 Body test configuration

The SAR Exclusion Threshold in KDB 447498 D01 can be applied to determine SAR test exclusion for adjacent edge configurations. The closest distance from the antenna to an EUT edge is used to determine if SAR testing is required for the adjacent edges, with the adjacent edge positioned adjacent the phantom and the edge containing the antenna positioned perpendicular to the phantom.

SAR test reduction and exclusion guidance

(1) The SAR exclusion threshold for distances < 50 mm is defined by the following equation:

$$P_{th} \text{ (mW)} = \begin{cases} ERP_{20 \text{ cm}}(d/20 \text{ cm})^x & d \leq 20 \text{ cm} \\ ERP_{20 \text{ cm}} & 20 \text{ cm} < d \leq 40 \text{ cm} \end{cases} \quad (\text{B. 2})$$

where

$$x = -\log_{10} \left(\frac{60}{ERP_{20 \text{ cm}} \sqrt{f}} \right)$$

and f is in GHz, d is the separation distance (cm), and $ERP_{20 \text{ cm}}$ is per Formula (B.1).

Example values shown in Table B.2 are for illustration only.

Table B.2—Example Power Thresholds (mW)

Frequency (MHz)	Distance (mm)									
	5	10	15	20	25	30	35	40	45	50
300	39	65	88	110	129	148	166	184	201	217
450	22	44	67	89	112	135	158	180	203	226
835	9	25	44	66	90	116	145	175	207	240
1900	3	12	26	44	66	92	122	157	195	236
2450	3	10	22	38	59	83	111	143	179	219
3600	2	8	18	32	49	71	96	125	158	195
5800	1	6	14	25	40	58	80	106	136	169

6.5. SAR Exclusion Calculations for Antenna

Mode	Ant	Position	Distance (mm)	f (MHz)	Max Power(dBm)	Max Power(mW)	SAR Exclusion threshold(mW)	Test required
Bluetooth	Aux	Rear Face	7.00	2402	7.50	5.62	5	Yes
Bluetooth	Aux	Right Side	38.00	2402	7.50	5.62	131	No
Bluetooth	Aux	Left Side	12.00	2402	7.50	5.62	15	No
Bluetooth	Aux	Top Side	3.00	2402	7.50	5.62	1	Yes
Bluetooth	Aux	Bottom Side	34.00	2402	7.50	5.62	106	No

The distance <50mm_WWAN

Mode	Position	Pmax (dBm)*	Pmax (mW)	Distance (mm)	f (GHz)	Calculation Result	SAR Exclusion threshold	Test Requirement (Yes/No)
Cat-M1 B2	Top	22.5	177.83	34	1.910	7.23	3	Yes
	Bottom	22.5	177.83	3	1.910	81.92	3	Yes
	Right	22.5	177.83	38	1.910	6.47	3	Yes
	Left	22.5	177.83	12	1.910	20.48	3	Yes
	Rear	22.5	177.83	7	1.910	35.11	3	Yes
Cat-M1 B4	Top	22.5	177.83	34	1.720	6.86	3	Yes
	Bottom	22.5	177.83	3	1.720	77.74	3	Yes
	Right	22.5	177.83	38	1.720	6.14	3	Yes
	Left	22.5	177.83	12	1.720	19.43	3	Yes
	Rear	22.5	177.83	7	1.720	33.32	3	Yes
Cat-M1 B12	Top	22.5	177.83	34	0.711	4.41	3	Yes
	Bottom	22.5	177.83	3	0.711	49.98	3	Yes
	Right	22.5	177.83	38	0.711	3.95	3	Yes
	Left	22.5	177.83	12	0.711	12.50	3	Yes
	Rear	22.5	177.83	7	0.711	21.42	3	Yes

7 CONDUCTED POWER RESULTS

7.1 Conducted power measurements of UHF

Cat-M1 Band 2 Power Table

LTE B2/BW=5M		Average Conducted Power(dBm)				LTE B2/BW=10M		Average Conducted Power(dBm)			
Modulation	RB Size/Offset	Max. Tune-up	Channel/Frequency(MHz)			Modulation	RB Size/Offset	Max. Tune-up	Channel/Frequency(MHz)		
			18625/1852.5	18900/1880	19175/1907.5				18650/1855	18900/1880	19150/1905
QPSK	1/0	22.5	20.1	20.3	20.7	QPSK	1/0	22.5	20.2	20.3	20.7
	6/0	22.5	20.0	20.3	20.6				6/0	22.5	20.1
16QAM	1/0	22.5	19.6	19.7	20.4	16QAM	1/0	22.5	19.7	19.8	20.5
	6/0	22.5	19.6	19.7	20.5				6/0	22.5	19.7
LTE B2/BW=15M		Average Conducted Power(dBm)				LTE B2/BW=20M		Average Conducted Power(dBm)			
Modulation	RB Size/Offset	Max. Tune-up	Channel/Frequency(MHz)			Modulation	RB Size/Offset	Max. Tune-up	Channel/Frequency(MHz)		
			18675/1857.5	18900/1880	19125/1902.5				18700/1860	18900/1880	19100/1900
QPSK	1/0	22.5	20.2	20.4	20.8	QPSK	1/0	22.5	20.3	20.4	20.8
	6/0	22.5	20.1	20.4	20.7				6/0	22.5	20.2
16QAM	1/0	22.5	19.7	19.8	20.5	16QAM	1/0	22.5	19.8	19.9	20.6
	6/0	22.5	19.7	19.8	20.6				6/0	22.5	19.8

Cat-M1 Band 4 Power Table

LTE B4/BW=5M		Average Conducted Power(dBm)				LTE B4/BW=10M		Average Conducted Power(dBm)			
Modulation	RB Size/Offset	Max. Tune-up	Channel/Frequency(MHz)			Modulation	RB Size/Offset	Max. Tune-up	Channel/Frequency(MHz)		
			19975/1712.5	20175/1732.5	20375/1752.5				20000/1715	20175/1732.5	20350/1750
QPSK	1/0	22.5	21.2	21.0	20.6	QPSK	1/0	22.5	21.3	21.0	20.7
	6/0	22.5	21.1	20.9	20.5				6/0	22.5	21.2
16QAM	1/0	22.5	20.8	20.5	20.1	16QAM	1/0	22.5	20.8	20.6	20.2
	6/0	22.5	20.7	20.4	20.1				6/0	22.5	20.8
LTE B4/BW=15M		Average Conducted Power(dBm)				LTE B4/BW=20M		Average Conducted Power(dBm)			
Modulation	RB Size/Offset	Max. Tune-up	Channel/Frequency(MHz)			Modulation	RB Size/Offset	Max. Tune-up	Channel/Frequency(MHz)		
			20025/1717.5	20175/1732.5	20325/1747.5				20050/1720	20175/1732.5	20300/1745
QPSK	1/0	22.5	21.3	21.1	20.7	QPSK	1/0	22.5	21.4	21.1	20.8
	6/0	22.5	21.2	21.0	20.6				6/0	22.5	21.3
16QAM	1/0	22.5	20.9	20.6	20.2	16QAM	1/0	22.5	20.9	20.7	20.3
	6/0	22.5	20.8	20.5	20.2				6/0	22.5	20.9

Cat-M1 Band 12 Power Table

LTE B12/BW=5M		Average Conducted Power(dBm)				LTE B12/BW=10M		Average Conducted Power(dBm)			
Modulation	RB Size/Offset	Max. Tune-up	Channel/Frequency(MHz)			Modulation	RB Size/Offset	Max. Tune-up	Channel/Frequency(MHz)		
			23035/701.5	23095/707.5	23155/713.5				23060/704	23095/707.5	23130/711
QPSK	1/0	22.5	22.0	22.1	22.1	QPSK	1/0	22.5	22.0	22.1	22.2
	6/0	22.5	21.0	21.1	21.2		6/0	22.5	21.1	21.2	21.2
16QAM	1/0	22.5	21.4	21.5	21.6	16QAM	1/0	22.5	21.5	21.6	21.7
	6/0	22.5	20.7	20.7	20.6		6/0	22.5	20.7	20.7	20.7

7.2. Conducted power measurement results of Bluetooth

Band	Mode	Channel	Frequency (MHz)	Max Power (dBm)	AVG Power (dBm)
BLE	1M	0	2402	7.50	7.14
		19	2440	7.50	6.78
		39	2480	7.50	6.25
	2M	0	2402	7.50	7.21
		19	2440	7.50	6.79
		39	2480	7.50	6.26

Mode	BLE 1M	BLE 2M
Duty cycle	62.66%	32.48%
Crest factor	1.60	3.08

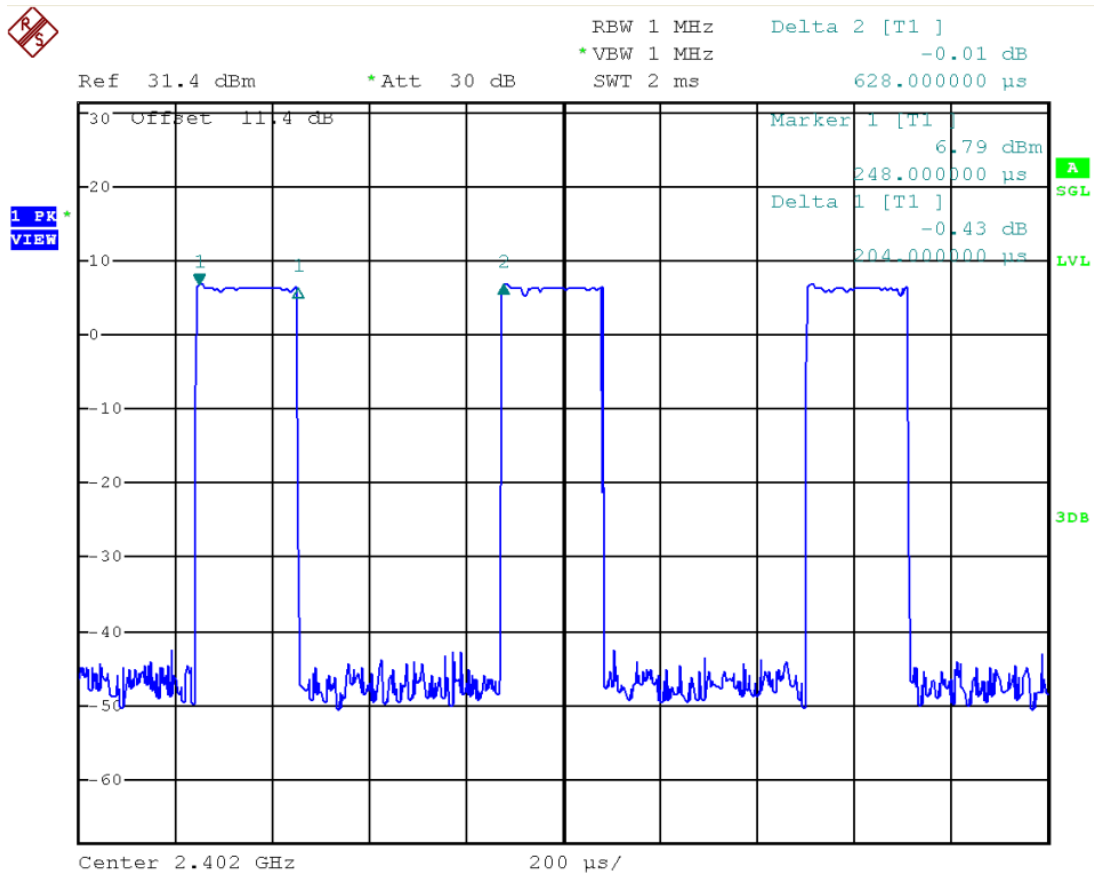

8 SAR TEST RESULTS

General Notes:

- 1) Per KDB447498 D01, all measurement SAR results are scaled to the maximum tune-up tolerance limit to demonstrate compliant.
- 2) Per KDB447498 D01, testing of other required channels within the operating mode of a frequency band is not required when the reported 1-g or 10-g SAR for the mid-band or highest output power channel is ≤ 0.8 W/kg or 2.0 W/kg, for 1-g or 10-g respectively, when the transmission band is ≤ 100 MHz. When the maximum output power variation across the required test channels is $> \frac{1}{2}$ dB, instead of the middle channel, the highest output power channel must be used.
- 3) Per KDB865664 D01, for each frequency band, repeated SAR measurement is required only when the measured SAR is ≥ 0.8 W/kg; if the deviation among the repeated measurement is $\leq 20\%$, and the measured SAR < 1.45 W/kg, only one repeated measurement is required.
- 4) Per KDB865664 D02, SAR plot is only required for the highest measured SAR in each exposure configuration, wireless mode and frequency band combination; Plots are also required when the measured SAR is > 1.5 W/kg, or > 7.0 W/kg for occupational exposure. The published RF exposure KDB procedures may require additional plots; for example, to support SAR to peak location separation ratio test exclusion and/or volume scan post-processing.

8.1 Body SAR test results

Mode	Channel	Test Position	Distance (cm)	Max Tune-up (dBm)	AVG Power (dBm)	Area Scan SAR 1g	SAR 1g	Duty Cycl %	Duty Factor	Reported SAR 1g	Note
BLE 2M	0	Top	0.5	7.50	7.21	0.020	0.036	32.48%	3.08	0.119	
	0	Rear	0.5	7.50	7.21	0.027	0.044	32.48%	3.08	0.145	

Test No.	Band	Mode	Channel	RB	Offset	Test Position	Separation Distance (cm)	Maximum Tune-up (dBm)	Conducted Power (dBm)	SAR 1g (W/kg)	Reported 1g SAR (W/kg)
T01	Cat-M1 B2	QPSK20M	19100	1	0	Bottom	0.5	22.50	20.80	0.279	0.413
T02	Cat-M1 B2	QPSK20M	19100	1	0	Top	0.5	22.50	20.80	0.031	0.046
T03	Cat-M1 B2	QPSK20M	19100	1	0	Left	0.5	22.50	20.80	0.038	0.057
T04	Cat-M1 B2	QPSK20M	19100	1	0	Right	0.5	22.50	20.80	0.003	0.004
T05	Cat-M1 B2	QPSK20M	19100	1	0	Rear	0.5	22.50	20.80	0.014	0.020
T06	Cat-M1 B4	QPSK20M	20050	1	0	Bottom	0.5	22.50	21.40	0.173	0.223
T07	Cat-M1 B4	QPSK20M	20050	1	0	Top	0.5	22.50	21.40	0.059	0.075
T08	Cat-M1 B4	QPSK20M	20050	1	0	Left	0.5	22.50	21.40	0.075	0.096
T09	Cat-M1 B4	QPSK20M	20050	1	0	Right	0.5	22.50	21.40	0.029	0.037
T10	Cat-M1 B4	QPSK20M	20050	1	0	Rear	0.5	22.50	21.40	0.053	0.068
T11	Cat-M1 B12	QPSK10M	23130	1	0	Bottom	0.5	22.50	22.20	0.260	0.279
T12	Cat-M1 B12	QPSK10M	23130	1	0	Top	0.5	22.50	22.20	0.157	0.168
T13	Cat-M1 B12	QPSK10M	23130	1	0	Left	0.5	22.50	22.20	0.082	0.088
T14	Cat-M1 B12	QPSK10M	23130	1	0	Right	0.5	22.50	22.20	0.004	0.004
T15	Cat-M1 B12	QPSK10M	23130	1	0	Rear	0.5	22.50	22.20	0.006	0.007

Note: The value with boldface is the maximum SAR Value of each test band.

9. MULTIPLE TRANSMITTER EVALUATION

9.1. Stand-alone SAR test exclusion

SAR compliance for simultaneous transmission must be considered when the maximum duration of overlapping transmissions, including network hand-offs, is greater than 30 seconds. This device contains multiple transmitters that may operate simultaneously, and therefore requires a simultaneous transmission analysis.

The Simultaneous Transmission Possibilities of this device are as below:

No.	Configuration	Body
1	WWAN Ant + Bluetooth Ant	YES

Note: BT antenna only supports the aux antenna.

9.2. Estimated SAR for Simultaneous Transmission SAR Analysis

Considerations for SAR estimation

- When standalone SAR test exclusion applies, standalone SAR must also be estimated to determine simultaneous transmission SAR test exclusion.
- Dedicated Host Approach criteria for SAR test exclusion is likewise applied to SAR estimation, with certain distinctions between test exclusion and SAR estimation:
 - When the separation distance from the antenna to an adjacent edge is ≤ 5 mm, a distance of 5 mm is applied for SAR estimation; this is the same between test exclusion and SAR estimation calculations.
 - When the separation distance from the antenna to an adjacent edge is > 5 mm but ≤ 50 mm, the actual antenna-to-edge separation distance is applied for SAR estimation.
 - When the minimum test separation distance is > 50 mm, the estimated SAR value is 0.4 W/kg

9.2.1 ESTIMATED SAR FOR BLUETOOTH

According to section 9, the Bluetooth must be estimated according to following to determine simultaneous transmission SAR test exclusion:

- $(\text{max. power of channel, including tune-up tolerance, mW}) / (\text{min. test separation distance, mm}) \cdot [\sqrt{f_{\text{(GHz)}}/x}] \text{ W/kg}$ for test separation distances ≤ 50 mm; where $x = 7.5$ for 1-g SAR, and $x = 18.75$ for 10-g SAR.
- 0.4 W/kg for 1-g SAR and 1.0 W/kg for 10-g SAR, when the test separation distances is > 50 mm.

Antenna	Band	Frequency (MHz)	Output Power		Separation Distances(mm)					Estimated 1-g SAR (W/kg)				
			dBm	mW	Rear	Top	Right	Left	Bottom	Rear	Top	Right	Left	Bottom
Bluetooth	2.4GHz	2440	7.50	6.00	7.00	3.00	38.00	12.00	34.00	Test	Test	0.001	0.035	0.003

9.3. Simultaneous transmission conditions

SAR10g(W/kg)	Test Position				
	Rear	Top	Right	Left	Bottom
WWAN Ant	0.068	0.168	0.037	0.096	0.413
BT Ant	0.145	0.119	0.001	0.035	0.003
WWAN+BT MAX \sum SAR _{1g}	0.213	0.287	0.038	0.131	0.416

Note: MAX. \sum SAR_{1g}=0.416 W/Kg<1.6 W/Kg, so Simultaneous SAR are not required

10. Test Layout

Specific Absorption Rate Test Layout



Liquid depth in the flat Phantom ($\geq 15\text{cm}$ depth)
HSL(750MHz)

HSL(1750-2600MHz)

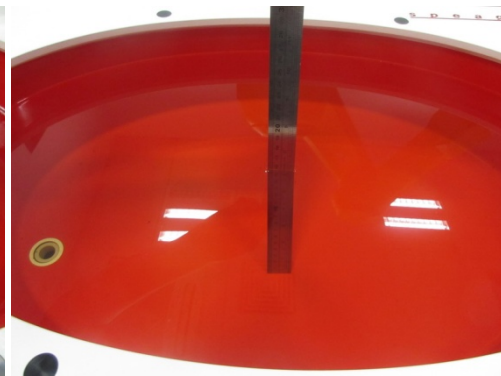

Appendix A. SAR Plots of System Verification

(Pls See BTL-FCC SAR-1-2007T023B_Appendix A.)

Appendix B. SAR Plots of SAR Measurement

(Pls See BTL-FCC SAR-1-2007T023B_Appendix B.)

Appendix C. Calibration Certificate

(Pls See BTL-FCC SAR-1-2007T023B_Appendix C.)

Appendix D. Photographs of the Test Set-Up

(Pls See BTL-FCC SAR-1-2007T023B_Appendix D.)

End of Test Report