

# FCC Radio Test Report

**FCC ID: 2AG5OPB-701-B**

**Report No.** : BTL-FCCP-2-2007T023  
**Equipment** : Pebblebee Found  
**Model Name** : PB-701-B  
**Brand Name** : Found  
**Applicant** : PB Inc.  
**Address** : PO Box 2962 Renton Washington United States 98056

**Radio Function** : LTE Cat-M1 Band 2

**FCC Rule Part(s)** : 47 CFR FCC Part 24 Subpart E  
47 CFR FCC Part 2  
ANSI/TIA/EIA-603-E-2016  
KDB 971168 D01 Power Meas License Digital Systems v03r01

**Measurement Procedure(s)** : ANSI C63.10-2013

**Date of Receipt** : 2020/7/9  
**Date of Test** : 2020/7/9 ~ 2020/7/24  
**Issued Date** : 2020/9/14

The above equipment has been tested and found in compliance with the requirement of the above standards by BTL Inc.

**Prepared by**

  
Peter Chen, Engineer

**Approved by**

  
Scott Hsu, Manager

**BTL Inc.**

No.18, Ln. 171, Sec. 2, Jiuzong Rd., Neihu Dist., Taipei City 114, Taiwan

Tel: +886-2-2657-3299

Fax: +886-2-2657-3331

Web: www.newbtl.com

**Declaration**

**BTL** represents to the client that testing is done in accordance with standard procedures as applicable and that test instruments used has been calibrated with standards traceable to international standard(s) and/or national standard(s).

**BTL's** reports apply only to the specific samples tested under conditions. It is manufacture's responsibility to ensure that additional production units of this model are manufactured with the identical electrical and mechanical components. **BTL** shall have no liability for any declarations, inferences or generalizations drawn by the client or others from **BTL** issued reports.

The report must not be used by the client to claim product certification, approval, or endorsement by NIST, A2LA, or any agency of the U.S. Government.

This report is the confidential property of the client. As a mutual protection to the clients, the public and ourselves, the test report shall not be reproduced, except in full, without our written approval.

**BTL's** laboratory quality assurance procedures are in compliance with the **ISO/IEC 17025** requirements, and accredited by the conformity assessment authorities listed in this test report.

**BTL** is not responsible for the sampling stage, so the results only apply to the sample as received.

The information, data and test plan are provided by manufacturer which may affect the validity of results, so it is manufacturer's responsibility to ensure that the apparatus meets the essential requirements of applied standards and in all the possible configurations as representative of its intended use.

**Limitation**

For the use of the authority's logo is limited unless the Test Standard(s)/Scope(s)/Item(s) mentioned in this test report is (are) included in the conformity assessment authorities acceptance respective.

Please note that the measurement uncertainty is provided for informational purpose only and are not use in determining the Pass/Fail results.

<b>Table of Contents</b>	<b>Page</b>
<b>REPORT ISSUED HISTORY</b>	<b>5</b>
<b>1 . SUMMARY OF TEST RESULTS</b>	<b>6</b>
1.1 TEST FACILITY	7
1.2 MEASUREMENT UNCERTAINTY	7
1.3 TEST ENVIRONMENT CONDITIONS	7
<b>2 . GENERAL INFORMATION</b>	<b>8</b>
2.1 GENERAL DESCRIPTION OF EUT	8
2.2 DESCRIPTION OF TEST MODES	9
2.3 BLOCK DIGRAM SHOWING THE CONFIGURATION OF SYSTEM TESTED	10
2.4 DESCRIPTION OF SUPPORT UNITS	10
<b>3 . TEST RESULT</b>	<b>11</b>
3.1 RADIATED POWER MEASUREMENT	11
3.1.1 LIMIT	11
3.1.2 TEST PROCEDURES	11
3.1.3 TEST SETUP LAYOUT	11
3.1.4 TEST DEVIATION	11
3.1.5 TEST RESULTS	11
3.2 OCCUPIED BANDWIDTH MEASUREMENT	12
3.2.1 TEST PROCEDURES	12
3.2.2 TEST SETUP LAYOUT	12
3.2.3 TEST DEVIATION	12
3.2.4 TEST RESULTS	12
3.3 CONDUCTED SPURIOUS EMISSIONS MEASUREMENT	13
3.3.1 LIMIT	13
3.3.2 TEST PROCEDURES	13
3.3.3 TEST SETUP LAYOUT	13
3.3.4 TEST DEVIATION	13
3.3.5 TEST RESULTS	13
3.4 RADIATED SPURIOUS EMISSIONS MEASUREMENT	14
3.4.1 LIMIT	14
3.4.2 TEST PROCEDURES	14
3.4.3 TEST SETUP LAYOUT	14
3.4.4 TEST DEVIATION	15
3.4.5 TEST RESULTS (30MHZ TO 1000MHZ)	15
3.4.6 TEST RESULTS (ABOVE 1000MHZ)	15
3.5 BAND EDGE MEASUREMENT	16
3.5.1 LIMIT	16
3.5.2 TEST PROCEDURES	16

<b>Table of Contents</b>	<b>Page</b>
3.5.3 TEST SETUP LAYOUT	16
3.5.4 TEST DEVIATION	16
3.5.5 TEST RESULTS	16
3.6 PEAK TO AVERAGE RATIO MEASUREMENT	17
3.6.1 LIMIT	17
3.6.2 TEST PROCEDURES	17
3.6.3 TEST SETUP LAYOUT	17
3.6.4 TEST DEVIATION	17
3.6.5 TEST RESULTS	17
3.7 FREQUENCY STABILITY MEASUREMENT	18
3.7.1 LIMIT	18
3.7.2 TEST PROCEDURES	18
3.7.3 TEST SETUP LAYOUT	18
3.7.4 TEST DEVIATION	18
3.7.5 TEST RESULTS	18
4. LIST OF MEASUREMENT EQUIPMENTS	19
5. EUT TEST PHOTOS	20
6. EUT PHOTOS	20
APPENDIX A - RADIATED POWER	21
APPENDIX B - OCCUPIED BANDWIDTH	23
APPENDIX C - CONDUCTED SPURIOUS EMISSIONS	32
APPENDIX D - RADIATED SPURIOUS EMISSIONS (30MHZ TO 1000MHZ)	37
APPENDIX E - RADIATED SPURIOUS EMISSIONS (ABOVE 1000MHZ)	40
APPENDIX F - BAND EDGE	43
APPENDIX G - PEAK TO AVERAGE RATIO	48
APPENDIX H - FREQUENCY STABILITY	53

**REPORT ISSUED HISTORY**

Report Version	Description	Issued Date
R00	Original Issue.	2020/9/7
R01	Revised report to address TCB's comments.	2020/9/14

## 1. SUMMARY OF TEST RESULTS

Test procedures according to the technical standard(s):

FCC Part 24 Subpart E & Part 2			
Standard(s) Section	Test Item	Judgment	Remark
2.1046 24.232(c)	Equivalent Isotropic Radiated Power	PASS	-----
2.1049	Occupied Bandwidth	PASS	-----
2.1051 24.238(a)	Conducted Spurious Emissions	PASS	-----
2.1053 24.238(a)	Radiated Spurious Emissions	PASS	-----
24.238(a)	Band Edge Measurements	PASS	-----
24.232(d)	Peak To Average Ratio	PASS	-----
2.1055 24.235	Frequency Stability	PASS	-----

Note:

- (1) "N/A" denotes test is not applicable in this test report.
- (2) The report format version is TP.1.1.1

## 1.1 TEST FACILITY

The test facilities used to collect the test data in this report:

No. 68-1, Ln. 169, Sec. 2, Datong Rd., Xizhi Dist., New Taipei City 221, Taiwan

The test sites and facilities are covered under FCC RN: 674415 and DN: TW0659.

- C05       CB08       CB11       CB15       CB16  
 SR06

## 1.2 MEASUREMENT UNCERTAINTY

The reported uncertainty of measurement  $y \pm U$ , where expanded uncertainty  $U$  is based on a standard uncertainty multiplied by a coverage factor of  $k = 2$ , providing a level of confidence of approximately **95 %**. The measurement instrumentation uncertainty considerations contained in CISPR 16-4-2. The BTL measurement uncertainty is less than the CISPR 16-4-2  $U_{\text{cispr}}$  requirement.

A. Radiated emissions test :

Test Site	Measurement Frequency Range	$U_1$ (dB)
CB15	0.03 GHz ~ 0.2 GHz	4.17
	0.2 GHz ~ 1 GHz	4.72
	1 GHz ~ 6 GHz	5.21
	6 GHz ~ 18 GHz	5.51
	18 GHz ~ 26 GHz	3.69
	26 GHz ~ 40 GHz	4.23

NOTE:

Unless specifically mentioned, the uncertainty of measurement has not been taken into account to declare the compliance or non-compliance to the specification.

## 1.3 TEST ENVIRONMENT CONDITIONS

Test Item	Environment Condition	Test Voltage	Tested by
Output Power	24.3 °C, 45 %	DC 5V	William Wei
EIRP	24.3 °C, 45 %	DC 5V	William Wei
Occupied Bandwidth	24.3 °C, 45 %	DC 5V	William Wei
Conducted Spurious Emissions	24.3 °C, 45 %	DC 5V	William Wei
Radiated Spurious Emissions	22 °C, 61 %	DC 5V	Aven Ho
Band Edge	24.3 °C, 45 %	DC 5V	William Wei
Peak to Average Ratio	24.3 °C, 45 %	DC 5V	William Wei
Frequency Stability	Normal and Extreme		William Wei

## 2. GENERAL INFORMATION

### 2.1 GENERAL DESCRIPTION OF EUT

Equipment	Pebblebee Found
Model Name	PB-701-B
Brand Name	Found
Model Difference	N/A
Power Source	Supplied from Battery.
Power Rating	I/P: DC 5V 1A
Products Covered	N/A
Hardware Version	PB_GO_DVT
Software Version	Firmware Ver: N.3.1.7
Test Model	PB-701-B
Sample Status	Engineering Sample
EUT Modification(s)	N/A
Modulation Type	UL: QPSK,16QAM DL: QPSK,16QAM
Maximum EIRP Power	16.47 dBm (0.0444 W)

Note:

1. For a more detailed features description, please refer to the manufacturer's specifications or the user's manual.

2. Channel List:

LTE Cat-M1 Band 2					
Test Frequency ID	Bandwidth (MHz)	N <sub>UL</sub>	Frequency of Uplink (MHz)	N <sub>DL</sub>	Frequency of Downlink (MHz)
Low Range	5	18625	1852.5	625	1932.5
	10	18650	1855	650	1935
	15	18675	1857.5	675	1937.5
	20	18700	1860	700	1940
Mid Range	5/10/15/20	18900	1880	900	1960
High Range	5	19175	1907.5	1175	1987.5
	10	19150	1905	1150	1985
	15	19125	1902.5	1125	1982.5
	20	19100	1900	1100	1980



## 2.2 DESCRIPTION OF TEST MODES

Following mode(s) is (were) found to be the worst case(s) and selected for the final test.

LTE CAT-M1 BAND 2 MODE					
Test Item	Available Channel	Tested Channel	Channel Bandwidth	Modulation	Mode
Output Power	18625 to 19175	18625, 18900, 19175	5MHz	QPSK, 16QAM	1RB/6RB
	18650 to 19150	18650, 18900, 19150	10MHz	QPSK, 16QAM	1RB/6RB
	18675 to 19125	18675, 18900, 19125	15MHz	QPSK, 16QAM	1RB/6RB
	18700 to 19100	18700, 18900, 19100	20MHz	QPSK, 16QAM	1RB/6RB
Occupied Bandwidth	18625 to 19175	18625, 18900, 19175	5MHz	QPSK, 16QAM	1RB/6RB
	18650 to 19150	18650, 18900, 19150	10MHz	QPSK, 16QAM	1RB/6RB
	18675 to 19125	18675, 18900, 19125	15MHz	QPSK, 16QAM	1RB/6RB
	18700 to 19100	18700, 18900, 19100	20MHz	QPSK, 16QAM	1RB/6RB
Conducted Spurious Emissions	18625 to 19175	18900	5MHz	QPSK	1RB
	18650 to 19150	18900	10MHz	QPSK	1RB
	18675 to 19125	18900	15MHz	QPSK	1RB
	18700 to 19100	18900	20MHz	QPSK	1RB
Radiated Spurious Emissions	Cat-M1				
Band Edge	18625 to 19175	18625, 19175	5MHz	QPSK	1RB/6RB
	18650 to 19150	18650, 19150	10MHz	QPSK	1RB/6RB
	18675 to 19125	18675, 19125	15MHz	QPSK	1RB/6RB
	18700 to 19100	18700, 19100	20MHz	QPSK	1RB/6RB
Peak To Average Ratio	18625 to 19175	18625, 18900, 19175	5MHz	QPSK, 16QAM	1RB
	18650 to 19150	18650, 18900, 19150	10MHz	QPSK, 16QAM	1RB
	18675 to 19125	18675, 18900, 19125	15MHz	QPSK, 16QAM	1RB
	18700 to 19100	18700, 18900, 19100	20MHz	QPSK, 16QAM	1RB
Frequency Stability				5MHz	
				10MHz	
				15MHz	
				20MHz	

### 2.3 BLOCK DIGRAM SHOWING THE CONFIGURATION OF SYSTEM TESTED

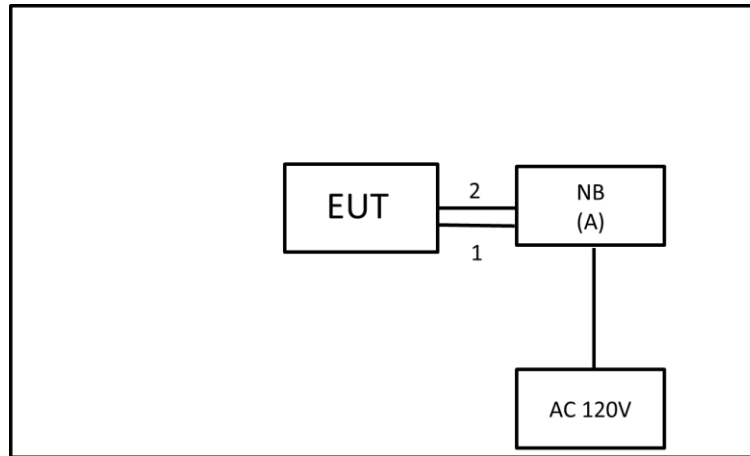

### 2.4 DESCRIPTION OF SUPPORT UNITS

The EUT has been tested as an independent unit together with other necessary accessories or support units. The following support units or accessories were used to form a representative test configuration during the tests.

Item	Equipment	Brand	Model No.	Series No.	Remarks
A	NB	HP	TPN-I119	NA	Furnished by test lab.

Item	Cable Type	Shielded	Ferrite Core	Length	Remarks
1	USB Cable	YES	NA	0.15M	Supplied by test requester
2	Fixture Cable to USB	NA	NA	0.5M	Supplied by test requester

### 3. TEST RESULT

#### 3.1 RADIATED POWER MEASUREMENT

##### 3.1.1 LIMIT

Mobile / Portable station are limited to 2 watts e.i.r.p.

##### 3.1.2 TEST PROCEDURES

1. Substitution method is used for E.I.R.P measurement. In the semi-anechoic chamber, EUT placed on the 0.8m height of Turn Table, rotated the table around 360 degrees to search the maximum radiation power and receiver antenna shall be rotated vertical and horizontal polarization and moved height from 1m to 4m to find the maximum polar radiated power. The "Read Value" is the spectrum reading the maximum power value.
2. The substitution horn antenna is substituted for EUT at the same position and signals generator export the CW signal to the substitution antenna via a TX cable. Rotated the Turn Table and moved receiving antenna to find the maximum radiation power. Adjust output power level of S.G to get a Value of spectrum reading equal to "Read Value " of step a. Record the power level of S.G
3.  $EIRP = \text{Output power level of S.G} - \text{TX cable loss} + \text{Antenna gain of substitution horn}$ .
4. E.R.P power can be calculated form E.I.R.P power by subtracting the gain of dipole,  $E.R.P \text{ power} = E.I.R.P \text{ power} - 2.15\text{dBi}$ .
5. The resolution bandwidth and video bandwidth of test receiver/spectrum analyzer is 1MHz/3MHz.

##### 3.1.3 TEST SETUP LAYOUT

###### Radiated Power Measurement

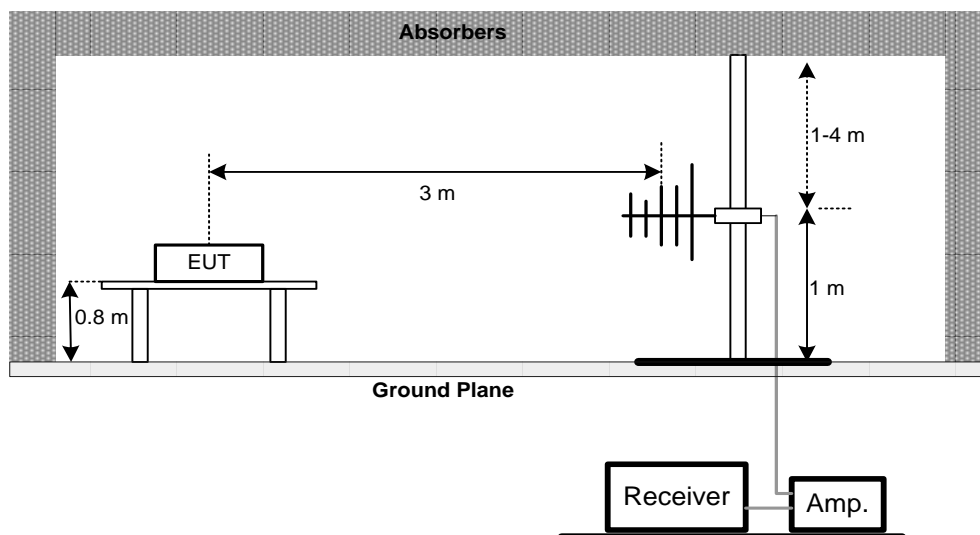

##### 3.1.4 TEST DEVIATION

No deviation

##### 3.1.5 TEST RESULTS

Please refer to the APPENDIX A.

## 3.2 OCCUPIED BANDWIDTH MEASUREMENT

### 3.2.1 TEST PROCEDURES

The testing follows FCC KDB 971168 v03r01 Section 4.

1. The EUT makes a call to the communication simulator. All measurements were done at low, middle and high operational frequency range. The communication simulator station system controlled a EUT to export maximum output power under transmission mode and specific channel frequency. Use OBW measurement function of Spectrum analyzer to measure 99 % occupied bandwidth and 26dB bandwidth.
2. The EUT was connected to spectrum analyzer and system simulator via a power divider.
3.  $RBW=(1\% \sim 5\%)*EBW$   
 $VBW \geq 3 * RBW$
4. Set spectrum analyzer with Peak detector.

### 3.2.2 TEST SETUP LAYOUT

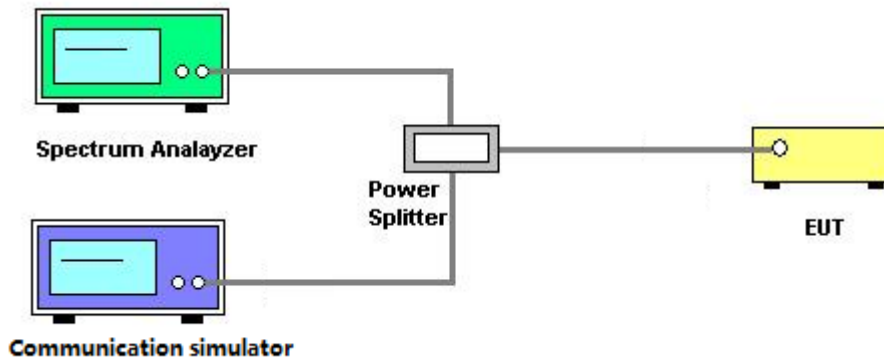

### 3.2.3 TEST DEVIATION

No deviation

### 3.2.4 TEST RESULTS

Please refer to the APPENDIX B.

### 3.3 CONDUCTED SPURIOUS EMISSIONS MEASUREMENT

#### 3.3.1 LIMIT

The power of any emission outside of the authorized operating frequency ranges must be attenuated below the transmitting power (P) by a factor of at least  $43 + 10 \log(P)$  dB. The emission limit equal to -13dBm.

#### 3.3.2 TEST PROCEDURES

The testing follows FCC KDB 971168 v03r01 Section 6.

1. The EUT was connected to spectrum analyzer and system simulator via a power divider.
2. The band edges of low and high channels for the highest RF powers were measured. Set RBW  $\geq 1\%$  EBW in the 1MHz band immediately outside and adjacent to the band edge.
3. Set spectrum analyzer with Peak detector.
4. The RF fundamental frequency should be excluded against the limit line in the operating frequency band.

#### 3.3.3 TEST SETUP LAYOUT

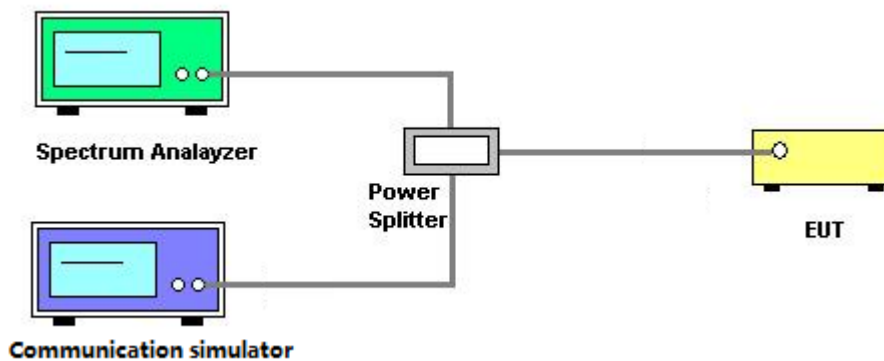

#### 3.3.4 TEST DEVIATION

No deviation

#### 3.3.5 TEST RESULTS

Please refer to the APPENDIX C.

### 3.4 RADIATED SPURIOUS EMISSIONS MEASUREMENT

#### 3.4.1 LIMIT

The power of any emission outside of the authorized operating frequency ranges must be attenuated below the transmitting power (P) by a factor of at least  $43 + 10 \log(P)$  dB. The emission limit equal to -13dBm.

#### 3.4.2 TEST PROCEDURES

The testing follows FCC KDB 971168 v03r01 Section 6.2.

1. In the semi-anechoic chamber, EUT placed on the 0.8m height of Turn Table, rotated the table around 360 degrees to search the maximum radiation power and receiver antenna shall be rotated vertical and horizontal polarization and moved height from 1m to 4m to find the maximum polar radiated power. The "Read Value" is the spectrum reading the maximum power value.
2. The substitution horn antenna is substituted for EUT at the same position and signals generator export the CW signal to the substitution antenna via a TX cable. Rotated the Turn Table and moved receiving antenna to find the maximum radiation power. Adjust output power level of S.G to get a Value of spectrum reading equal to "Read Value" of step a. Record the power level of S.G
3.  $EIRP = \text{Output power level of S.G} - \text{TX cable loss} + \text{Antenna gain of substitution horn}$ .
4. ERP can be calculated form EIRP by subtracting the gain of dipole,  $ERP = EIPR - 2.15\text{dBi}$ .
5. The resolution bandwidth and video bandwidth of test receiver/spectrum analyzer is 1MHz/3MHz.

#### 3.4.3 TEST SETUP LAYOUT

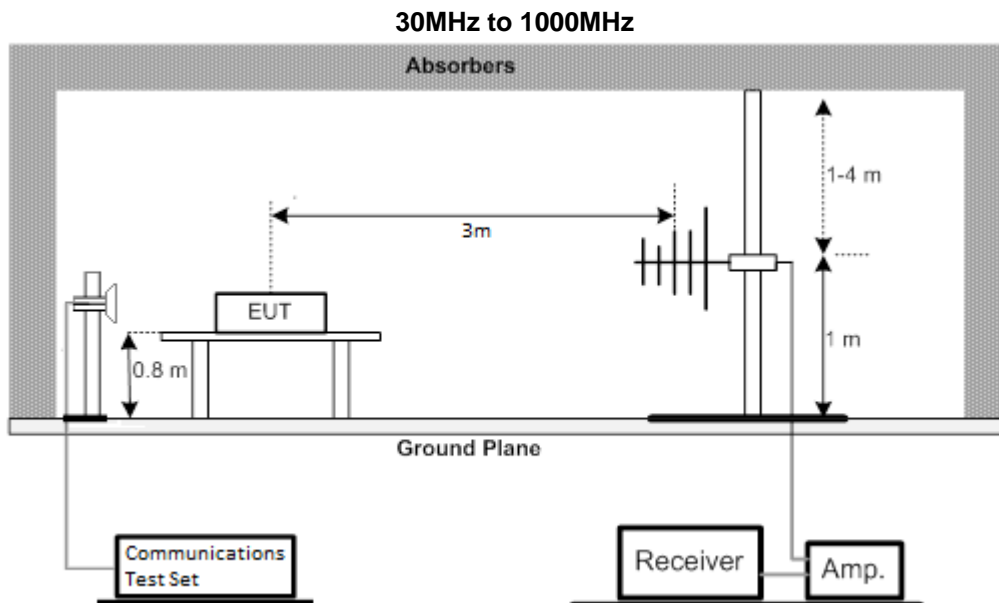

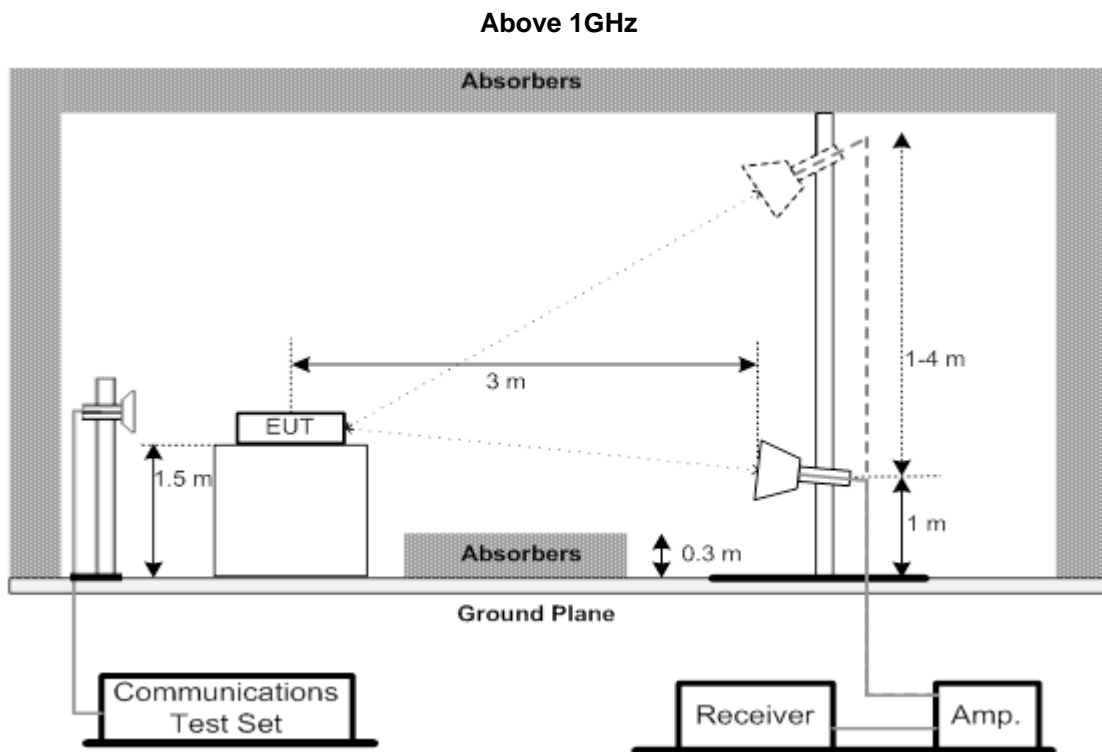

### 3.4.4 TEST DEVIATION

No deviation

### 3.4.5 TEST RESULTS (30MHZ TO 1000MHZ)

Please refer to the APPENDIX D.

### 3.4.6 TEST RESULTS (ABOVE 1000MHZ)

Please refer to the APPENDIX E.

### 3.5 BAND EDGE MEASUREMENT

#### 3.5.1 LIMIT

A Power of any emission outside of the authorized operating frequency ranges must be attenuated below the transmitting power (P) by a factor of at least  $43 + 10 \log(P)$  dB. In the 1 MHz bands immediately outside and adjacent to the frequency block a resolution bandwidth of at least one percent of the emission bandwidth of the fundamental emission of the transmitter may be employed.

#### 3.5.2 TEST PROCEDURES

The testing follows FCC KDB 971168 v03r01 Section 6.

1. All measurements were done at low and high operational frequency range.
2. Record the max trace plot into the test report.

#### 3.5.3 TEST SETUP LAYOUT

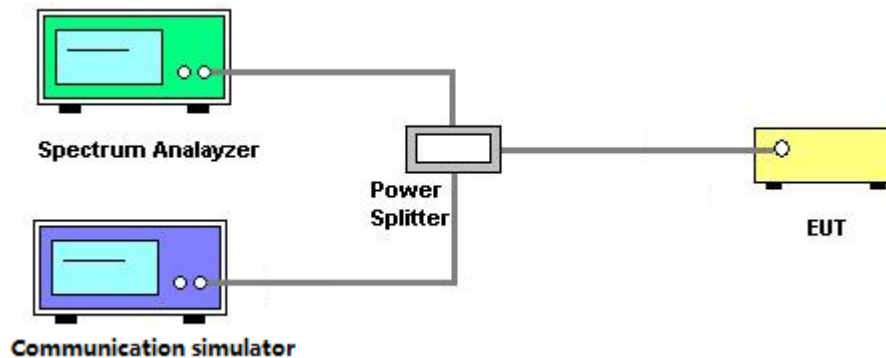

#### 3.5.4 TEST DEVIATION

No deviation

#### 3.5.5 TEST RESULTS

Please refer to the APPENDIX F.



### 3.6 PEAK TO AVERAGE RATIO MEASUREMENT

#### 3.6.1 LIMIT

In measuring transmissions in this band using an average power technique, the peak to-average ratio (PAR) of the transmission may not exceed 13 dB.

#### 3.6.2 TEST PROCEDURES

The testing follows FCC KDB 971168 v03r01 Section 5.7.

1. Set resolution/measurement bandwidth  $\geq$  signal's occupied bandwidth;
2. Set the number of counts to a value that stabilizes the measured CCDF curve;
3. Record the maximum PAPR level associated with a probability of 0.1%.

#### 3.6.3 TEST SETUP LAYOUT

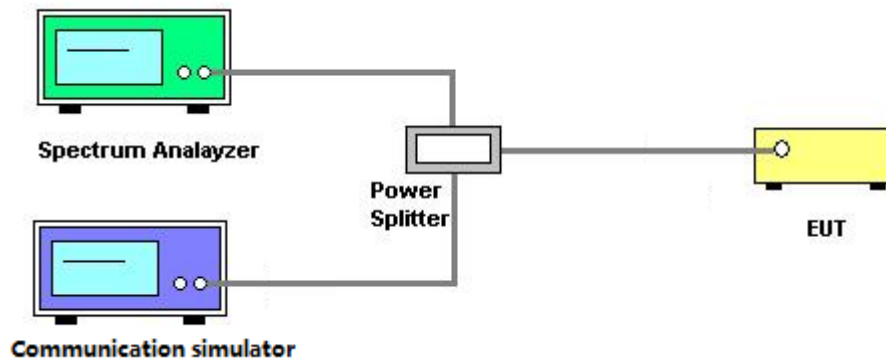

#### 3.6.4 TEST DEVIATION

No deviation

#### 3.6.5 TEST RESULTS

Please refer to the APPENDIX G.

### 3.7 FREQUENCY STABILITY MEASUREMENT

#### 3.7.1 LIMIT

$\pm 1.5$  ppm is for base and fixed station.  $\pm 2.5$  ppm is for mobile station.

#### 3.7.2 TEST PROCEDURES

The testing follows FCC KDB 971168 v03r01 Section 9.

1. Device is placed at the oven room. The oven room could control the temperatures and humidity. Power warm up is at least 15 min and power applied should perform before recording frequency error.
2. EUT is connected the external power supply to control the DC input power. The test voltage range is from minimum to maximum working voltage. Each step shall be record the frequency error rate.
3. The temperature range step is 10 degrees in this test items. All temperature levels shall be hold the  $\pm 0.5^\circ\text{C}$  during the measurement testing. The each temperature step shall be at least 0.5 hours, consider the EUT could be test under the stability condition.
4. The frequency error was recorded frequency error from the communication simulator.

#### 3.7.3 TEST SETUP LAYOUT

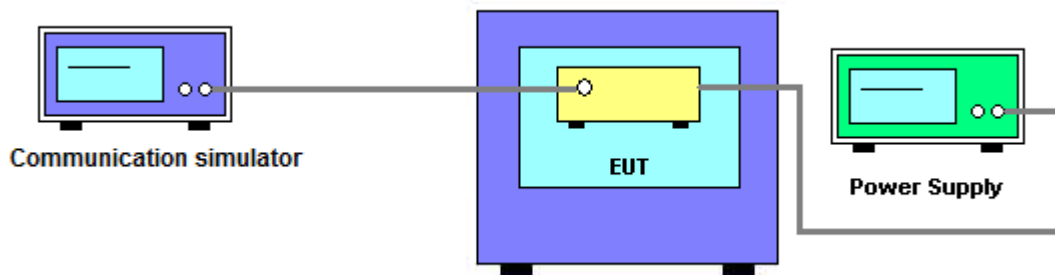

#### 3.7.4 TEST DEVIATION

No deviation

#### 3.7.5 TEST RESULTS

Please refer to the APPENDIX H.

#### 4. LIST OF MEASUREMENT EQUIPMENTS

ERIP Power Measurement						
Item	Kind of Equipment	Manufacturer	Type No.	Serial No.	Calibrated Date	Calibrated Until
1	Radio Communication Analyzer	Anritsu	MT8821C	6262044728	2019/12/3	2020/12/2

Radiated Emissions Measurement						
Item	Kind of Equipment	Manufacturer	Type No.	Serial No.	Calibrated Date	Calibrated Until
1	Preamplifier	EMCI	EMC001340	980555	2020/4/10	2021/4/9
2	Preamplifier	EMCI	EMC02325B	980217	2020/4/10	2021/4/9
3	Preamplifier	EMCI	EMC012645B	980267	2020/4/10	2021/4/9
4	Test Cable	EMCI	EMC104-SM-SM-800	150207	2020/4/10	2021/4/9
5	Test Cable	EMCI	EMC104-SM-SM-3000	151205	2020/4/10	2021/4/9
6	Test Cable	EMCI	EMC-SM-SM-7000	180408	2020/4/10	2021/4/9
7	MXE EMI Receiver	Agilent	N9038A	MY554200087	2020/6/10	2021/6/9
8	Signal Analyzer	Agilent	N9010A	MY56480554	2020/6/4	2021/6/3
9	Loop Ant	EMCO	6502	274	2020/6/16	2021/6/15
10	Horn Ant	SCHWARZBECK	BBHA 9120D	9120D-01783	2019/8/14	2020/8/13
11	Trilog-Broadband Antenna	Schwarzbeck	VULB 9168	0992	2020/7/10	2021/7/9
12	5dB Attenuator	EMCI	EMCI-N-6-05	AT-N0508	2020/7/10	2021/7/9

Frequency Stability Measurement						
Item	Kind of Equipment	Manufacturer	Type No.	Serial No.	Calibrated Date	Calibrated Until
1	Radio Communication Analyzer	Anritsu	MT8821C	6262044728	43802	2020/12/2
2	Thermal Chamber	HOLINK	H-T-1F-D	BA03101701	2020/7/2	2021/7/1

Others Conducted Measurement						
Item	Kind of Equipment	Manufacturer	Type No.	Serial No.	Calibrated Date	Calibrated Until
1	Spectrum Analyzer	Agilent	N9010A	MY54200240	2019/11/19	2020/11/18

Remark: "N/A" denotes no model name, no serial no. or no calibration specified.  
All calibration period of equipment list is one year.

**5. EUT TEST PHOTOS**

Please refer to document Appendix No.: TP-2007T023-FCCP-2 (APPENDIX-TEST PHOTOS).

**6. EUT PHOTOS**

Please refer to document Appendix No.: EP-2007T023-1 (APPENDIX-EUT PHOTOS).

## APPENDIX A - RADIATED POWER

Test Mode	LTE Cat-M1 Band 2	Test Date	2020/7/24
-----------	-------------------	-----------	-----------

Band	BW (MHz)	Channel	Frequency (MHz)	Mode	Narrowband Index	UL RB Allocation	UL RB Offset	Average power (dBm)	EIRP power (dBm)	
2	5	18625	1852.5	QPSK	0	1	0	20.12	15.75	
					0	6	0	20.03	15.66	
				16QAM	0	1	0	19.63	15.26	
		0	6		0	19.64	15.27			
		18900	1880.0	QPSK	0	1	0	20.29	15.92	
					0	6	0	20.26	15.89	
	16QAM			0	1	0	19.73	15.36		
		0	6	0	19.66	15.29				
	19175	1907.5	QPSK	0	1	5	20.69	16.32		
				0	6	0	20.63	16.26		
			16QAM	3	1	5	20.41	16.04		
	3	6		0	20.47	16.10				
2	10	18650	1855.0	QPSK	0	1	0	20.17	15.80	
					0	6	0	20.08	15.71	
				16QAM	0	1	0	19.68	15.31	
		0	6		0	19.69	15.32			
		18900	1880.0	QPSK	0	1	0	20.34	15.97	
					0	6	0	20.31	15.94	
				16QAM	0	1	0	19.78	15.41	
		0	6		0	19.71	15.34			
		19150	1905.0	QPSK	0	1	5	20.74	16.37	
	0				6	0	20.68	16.31		
	16QAM			7	1	5	20.46	16.09		
		7	6	0	20.52	16.15				
	2	15	18675	1857.5	QPSK	0	1	0	20.22	15.85
						0	6	0	20.13	15.76
					16QAM	0	1	0	19.73	15.36
			0	6		0	19.74	15.37		
			18900	1880.0	QPSK	0	1	0	20.39	16.02
						0	6	0	20.36	15.99
16QAM					0	1	0	19.83	15.46	
			0	6	0	19.76	15.39			
19125			1902.5	QPSK	0	1	5	20.79	16.42	
		0			6	0	20.73	16.36		
		16QAM		11	1	5	20.51	16.14		
11			6	0	20.57	16.20				
2		20	18700	1860.0	QPSK	0	1	0	20.27	15.90
						0	6	0	20.18	15.81
					16QAM	0	1	0	19.78	15.41
	0		6	0		19.79	15.42			
	18900		1880.0	QPSK	0	1	0	20.44	16.07	
					0	6	0	20.41	16.04	
		16QAM		0	1	0	19.88	15.51		
	0		6	0	19.81	15.44				
	19100	1900.0	QPSK	0	1	5	20.84	16.47		
				0	6	0	20.78	16.41		
			16QAM	15	1	5	20.56	16.19		
	15	6		0	20.62	16.25				

Antenna Gain: -4.37 dBi.

## APPENDIX B - OCCUPIED BANDWIDTH

Test Mode	LTE Cat-M1 Band 2	Test Date	2020/7/24
-----------	-------------------	-----------	-----------

## LTE Cat-M1 Band 2\_5M

## QPSK

Channel	Frequency (MHz)	99% Occupied Bandwidth (MHz)	Channel	Frequency (MHz)	26dB Bandwidth (MHz)
18625	1852.5	1.0930	18625	1852.5	1.496
18900	1880.0	1.0973	18900	1880.0	1.385
19175	1907.5	1.0901	19175	1907.5	1.417

## 16QAM

Channel	Frequency (MHz)	99% Occupied Bandwidth (MHz)	Channel	Frequency (MHz)	26dB Bandwidth (MHz)
18625	1852.5	1.0937	18625	1852.5	1.478
18900	1880.0	1.0954	18900	1880.0	1.390
19175	1907.5	1.0950	19175	1907.5	1.407



## Spectrum Plot

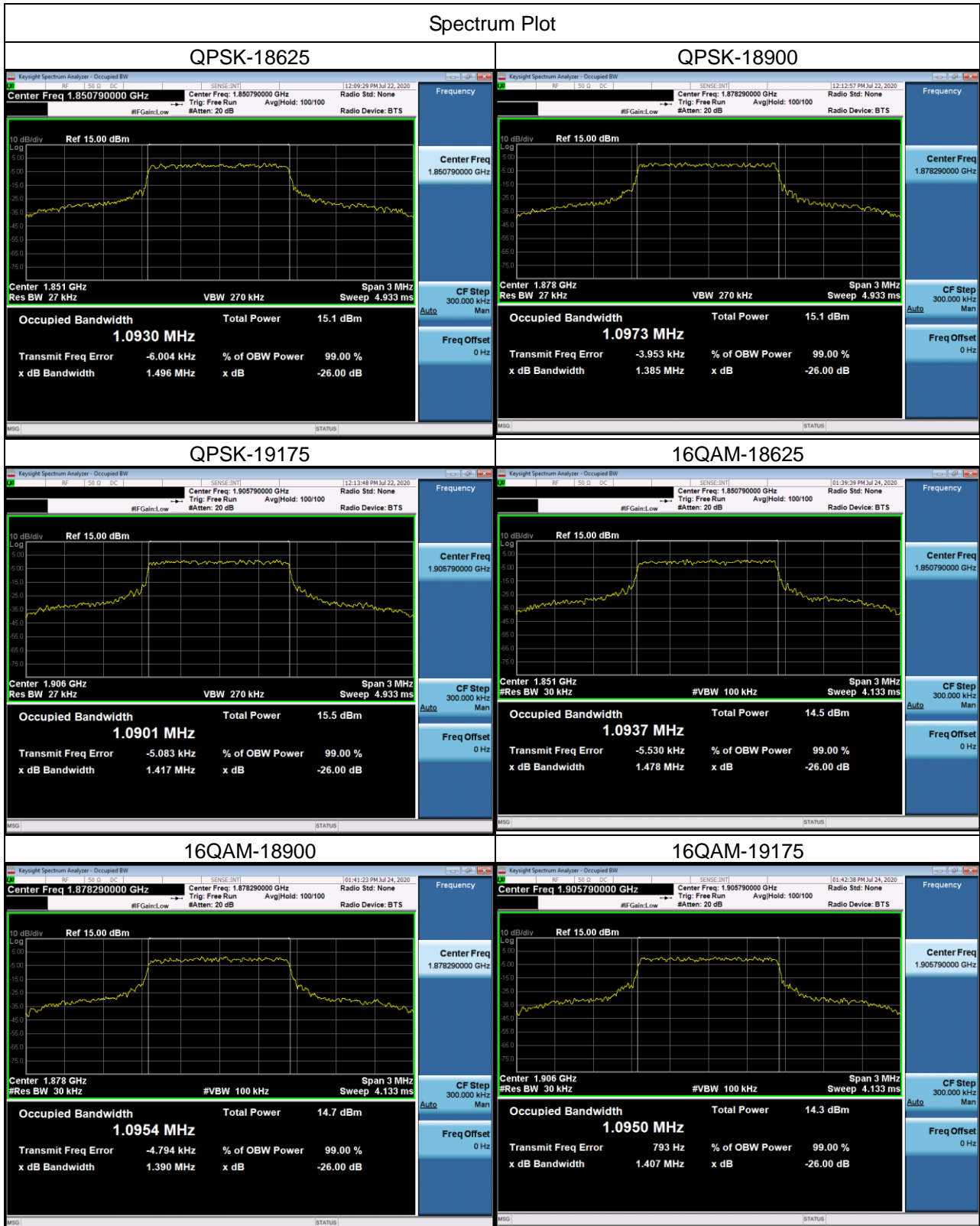

LTE Cat-M1 Band 2_10M					
QPSK					
Channel	Frequency (MHz)	99% Occupied Bandwidth (MHz)	Channel	Frequency (MHz)	26dB Bandwidth (MHz)
18650	1855	1.0950	18650	1855	1.494
18900	1880	1.0896	18900	1880	1.449
19150	1905	1.0895	19150	1905	1.432
16QAM					
Channel	Frequency (MHz)	99% Occupied Bandwidth (MHz)	Channel	Frequency (MHz)	26dB Bandwidth (MHz)
18650	1855	1.0910	18650	1855	1.522
18900	1880	1.0949	18900	1880	1.451
19150	1905	1.0947	19150	1905	1.435

## Spectrum Plot

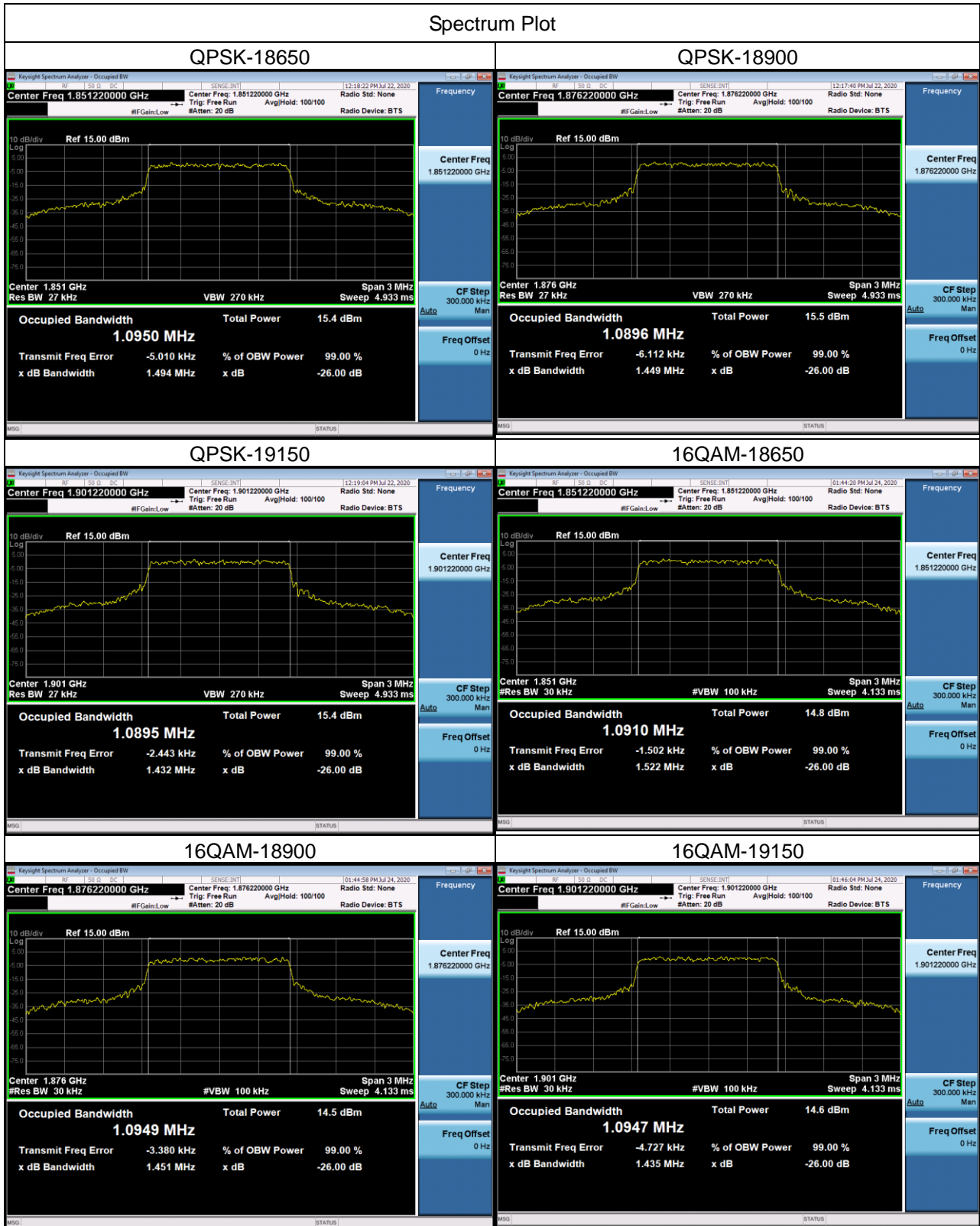

LTE Cat-M1 Band 2_15M					
QPSK					
Channel	Frequency (MHz)	99% Occupied Bandwidth (MHz)	Channel	Frequency (MHz)	26dB Bandwidth (MHz)
18675	1857.5	1.0981	18675	1857.5	1.585
18900	1880.0	1.0979	18900	1880.0	1.587
19125	1902.5	1.0969	19125	1902.5	1.462
16QAM					
Channel	Frequency (MHz)	99% Occupied Bandwidth (MHz)	Channel	Frequency (MHz)	26dB Bandwidth (MHz)
18675	1857.5	1.0985	18675	1857.5	2.014
18900	1880.0	1.0949	18900	1880.0	1.616
19125	1902.5	1.0939	19125	1902.5	1.413

## Spectrum Plot

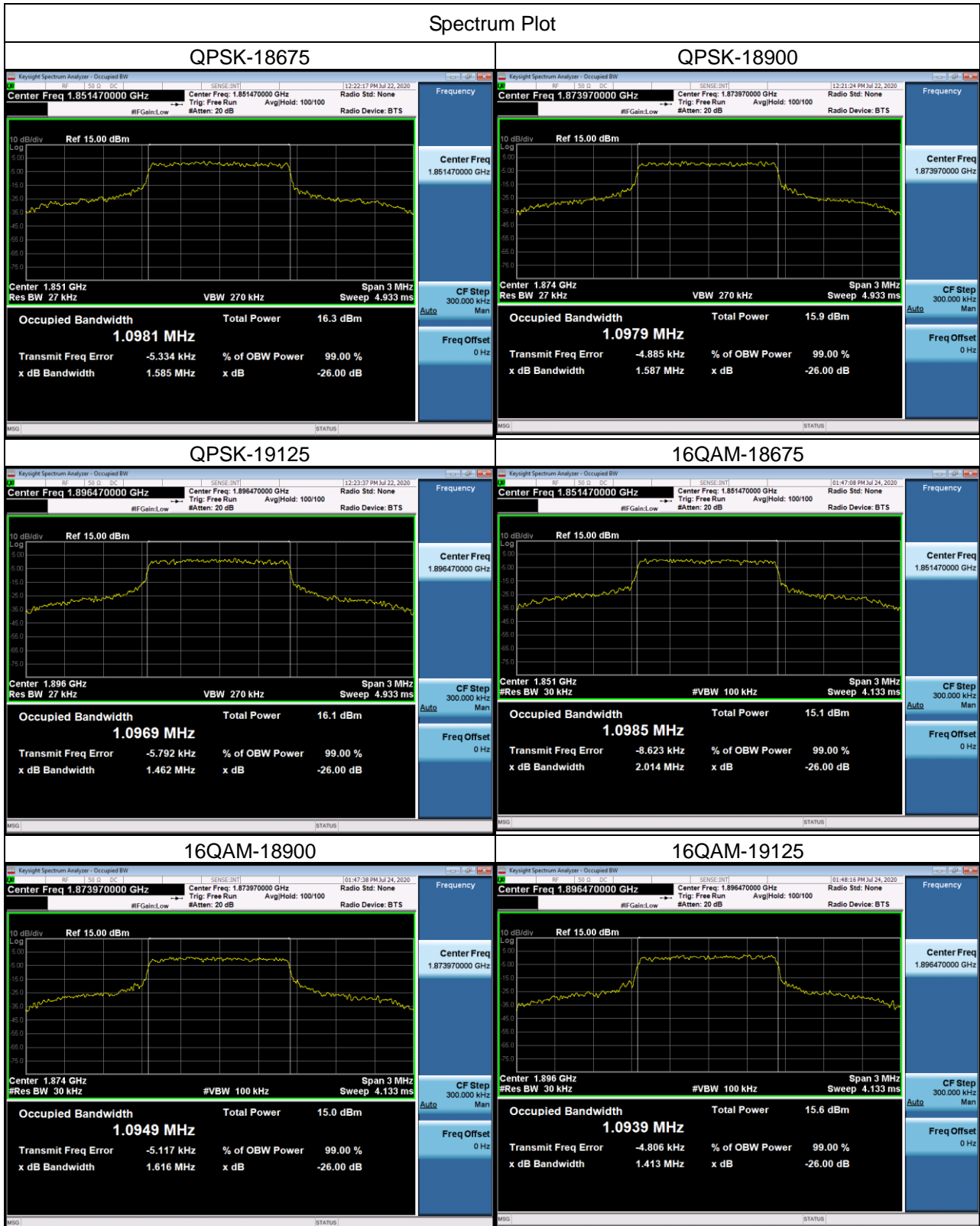

LTE Cat-M1 Band 2_20M					
QPSK					
Channel	Frequency (MHz)	99% Occupied Bandwidth (MHz)	Channel	Frequency (MHz)	26dB Bandwidth (MHz)
18700	1860	1.1043	18700	1860	1.690
18900	1880	1.0961	18900	1880	1.593
19100	1900	1.0921	19100	1900	1.496
16QAM					
Channel	Frequency (MHz)	99% Occupied Bandwidth (MHz)	Channel	Frequency (MHz)	26dB Bandwidth (MHz)
18700	1860	1.1056	18700	1860	1.856
18900	1880	1.1010	18900	1880	1.508
19100	1900	1.1004	19100	1900	1.455

## Spectrum Plot

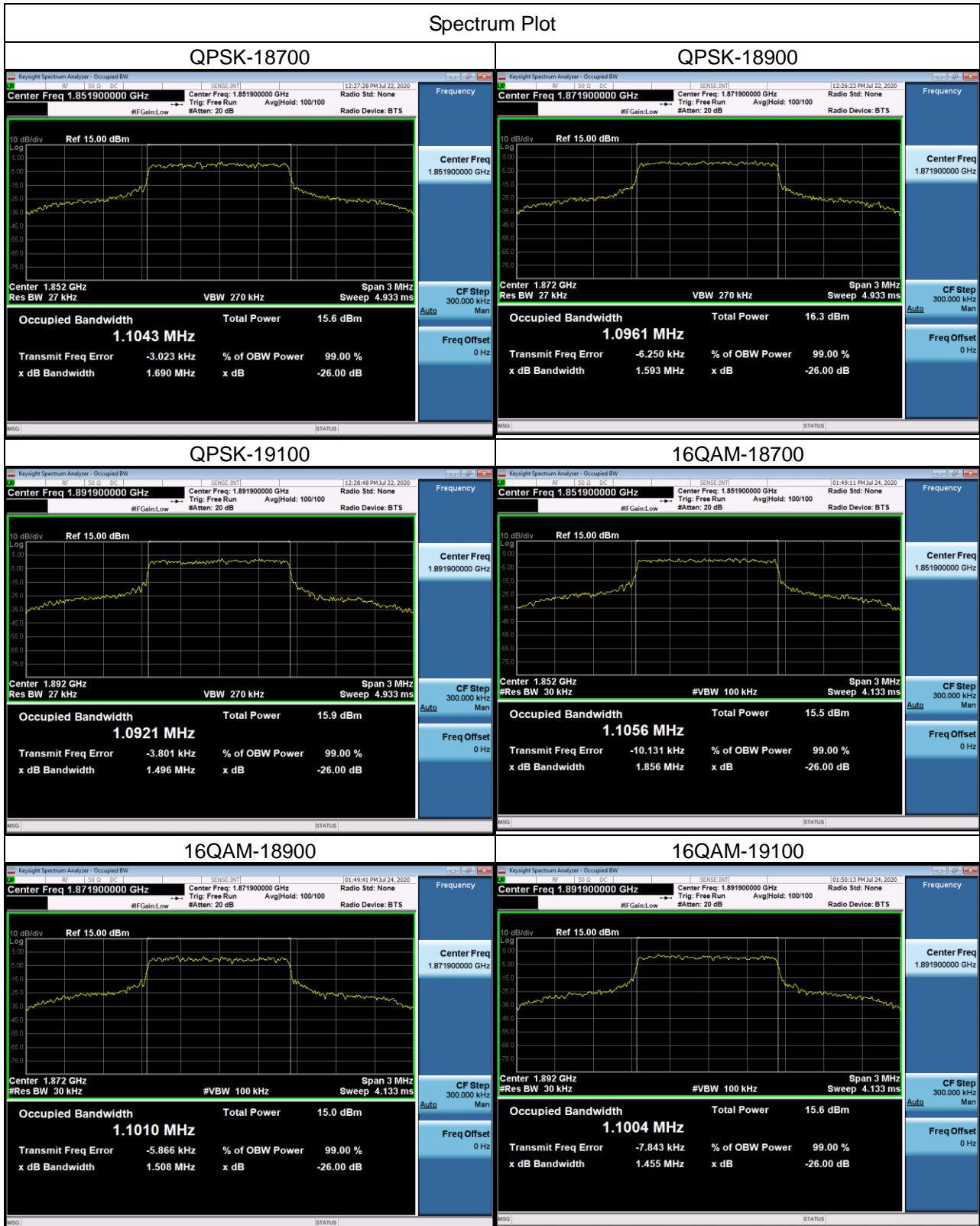

## **APPENDIX C - CONDUCTED SPURIOUS EMISSIONS**



Test Mode	LTE Cat-M1 Band 2	Test Date	2020/7/24
-----------	-------------------	-----------	-----------

LTE Cat-M1 Band 2\_5M Spectrum Plot

Channel	Frequency(MHz)
18900	1880

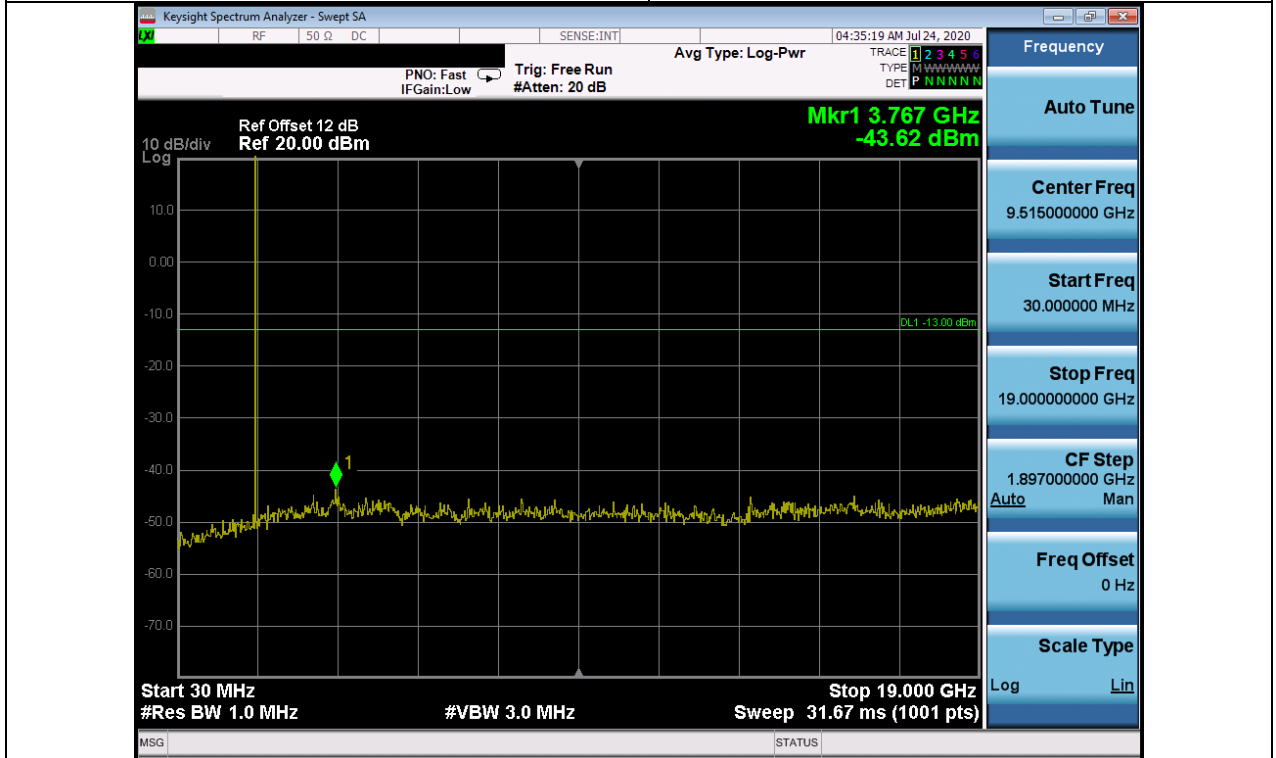

## LTE Cat-M1 Band 2\_10M Spectrum Plot

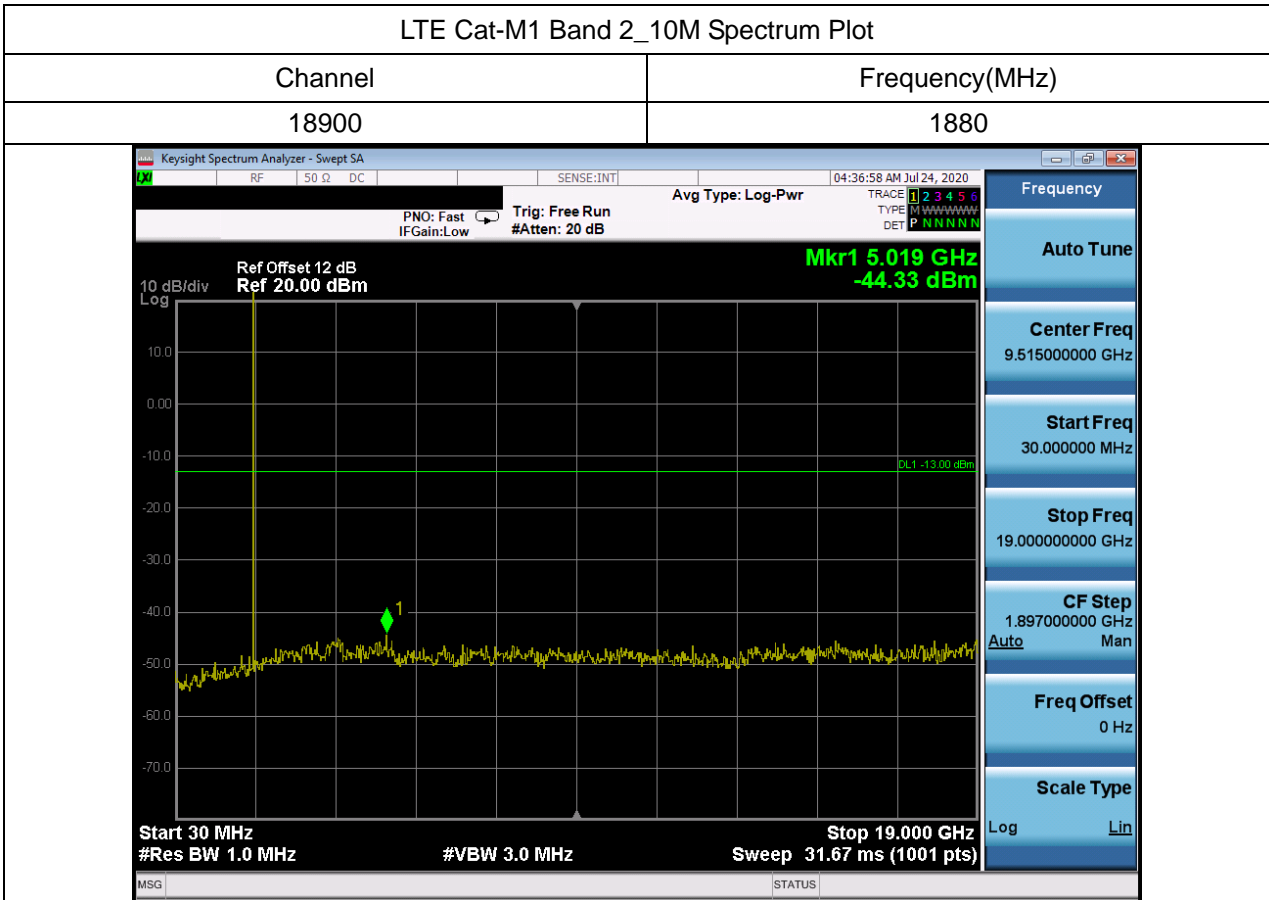

## LTE Cat-M1 Band 2\_15M Spectrum Plot

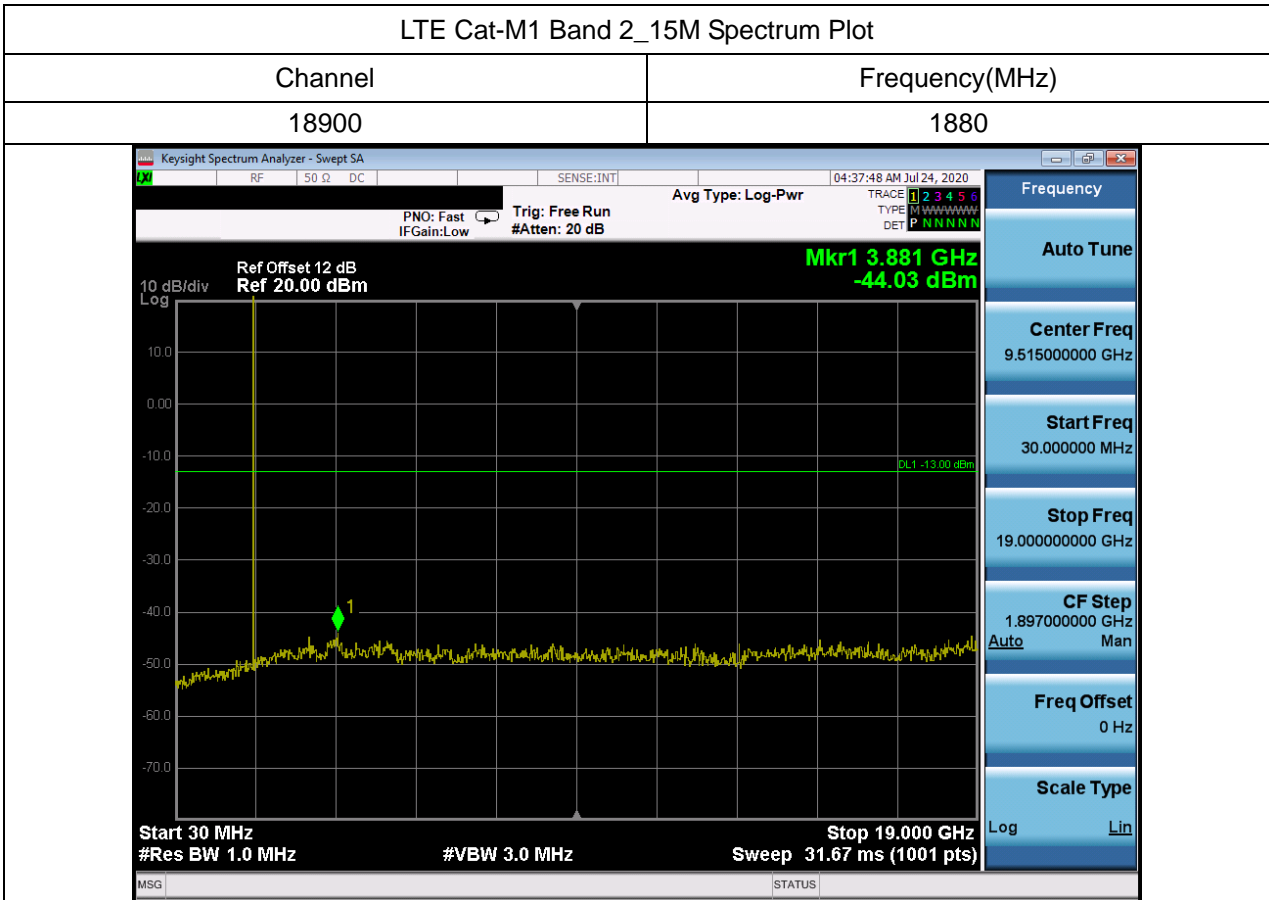

## LTE Cat-M1 Band 2\_20M Spectrum Plot

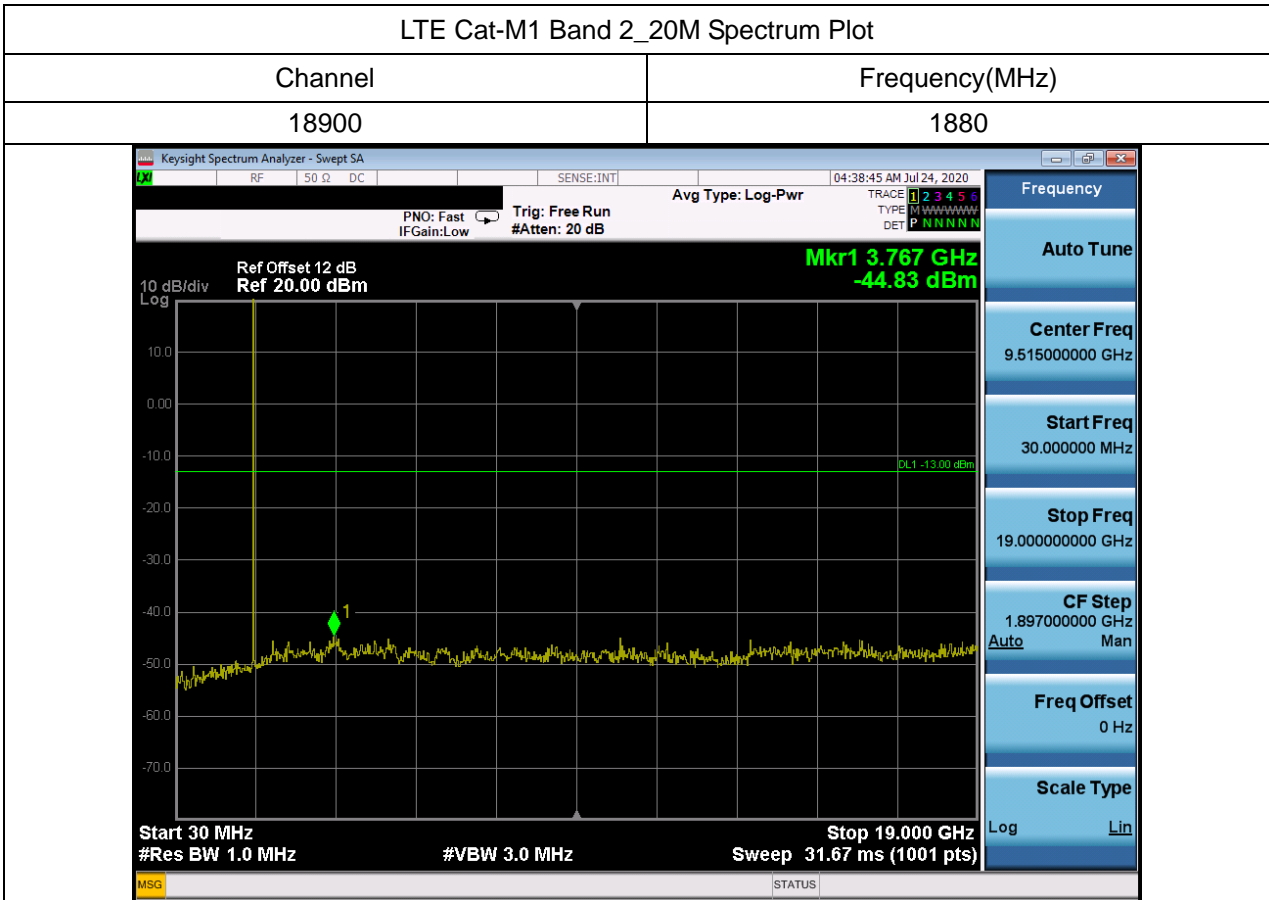

## **APPENDIX D - RADIATED SPURIOUS EMISSIONS (30MHZ TO 1000MHZ)**

Test Mode	LTE Cat-M1 Band 2	Test Date	2020/7/24
-	-	Polarization	Vertical

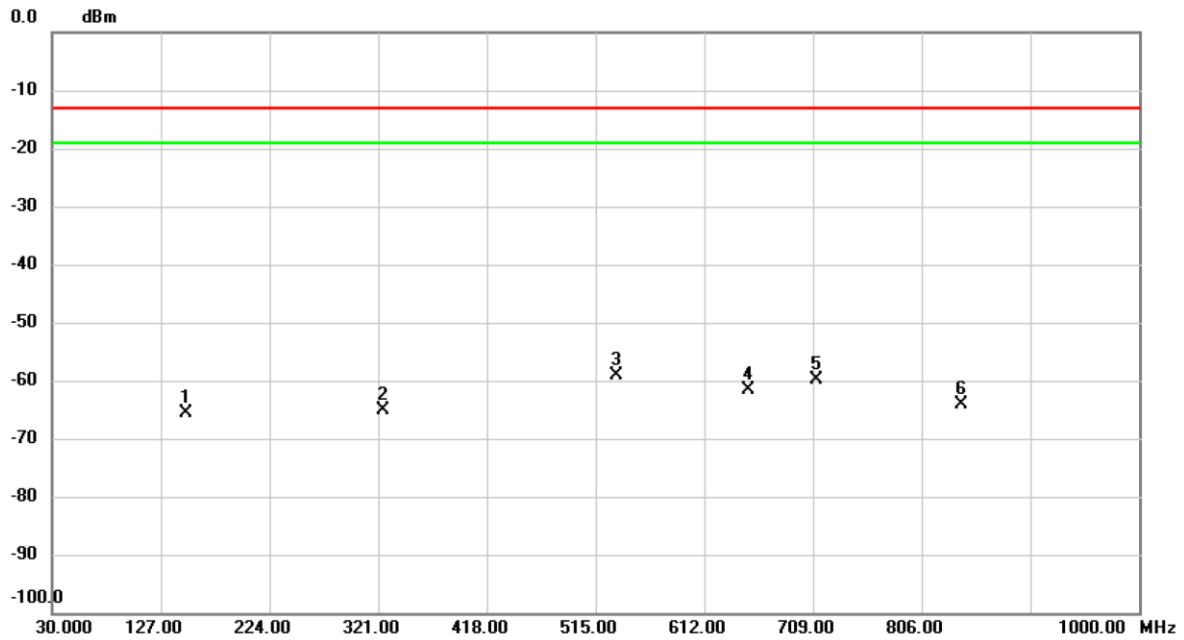

No.	Mk.	Freq. MHz	Reading Level dBm	Correct Factor dB	Measure- ment dBm	Limit dBm	Over dB	Detector	Comment
1		149.3100	-68.78	3.10	-65.68	-13.00	-52.68	peak	
2		324.8800	-72.29	7.13	-65.16	-13.00	-52.16	peak	
3	*	533.4300	-67.37	8.36	-59.01	-13.00	-46.01	peak	
4		651.7700	-74.23	12.70	-61.53	-13.00	-48.53	peak	
5		711.9100	-72.24	12.40	-59.84	-13.00	-46.84	peak	
6		841.8900	-73.91	9.69	-64.22	-13.00	-51.22	peak	

**REMARKS:**

(1) Measurement Value = Reading Level + Correct Factor.

(2) Margin Level = Measurement Value - Limit Value.

Test Mode	LTE Cat-M1 Band 2	Test Date	2020/7/24
-	-	Polarization	Horizontal

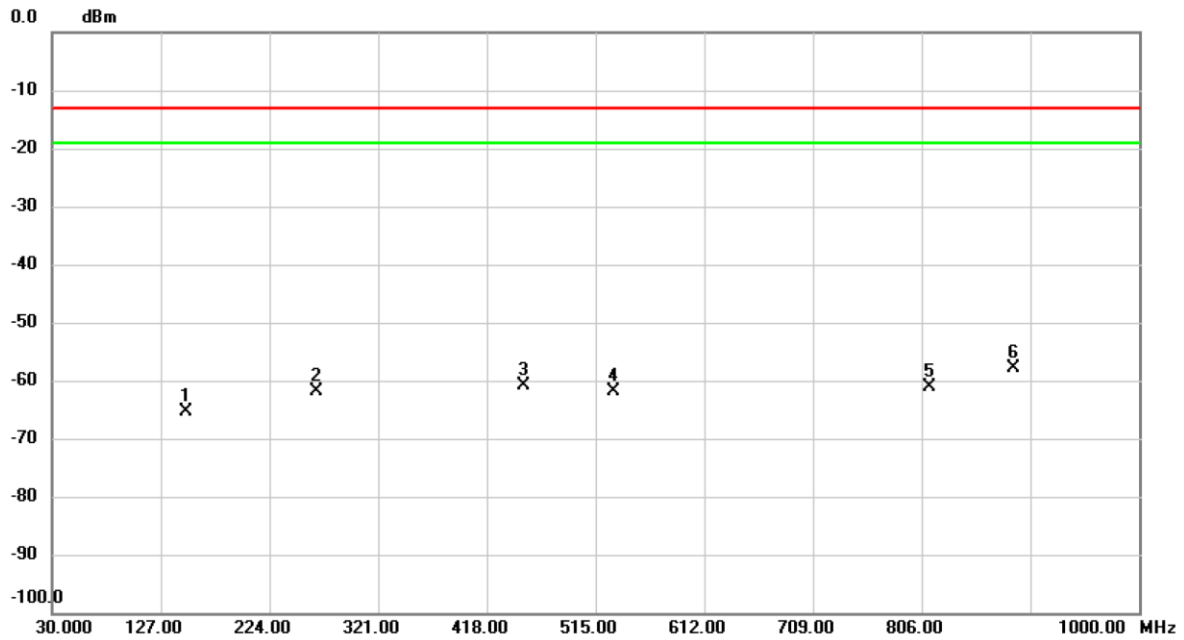

No.	Mk.	Freq. MHz	Reading Level dBm	Correct Factor dB	Measure- ment dBm	Limit dBm	Over dB	Detector	Comment
1		149.3100	-68.22	2.89	-65.33	-13.00	-52.33	peak	
2		265.7100	-61.64	-0.21	-61.85	-13.00	-48.85	peak	
3		450.9800	-76.27	15.29	-60.98	-13.00	-47.98	peak	
4		531.4900	-71.90	10.09	-61.81	-13.00	-48.81	peak	
5		812.7900	-76.50	15.50	-61.00	-13.00	-48.00	peak	
6	*	888.4500	-73.65	15.88	-57.77	-13.00	-44.77	peak	

**REMARKS:**

(1) Measurement Value = Reading Level + Correct Factor.

(2) Margin Level = Measurement Value - Limit Value.

## **APPENDIX E - RADIATED SPURIOUS EMISSIONS (ABOVE 1000MHZ)**



Test Mode	LTE Cat-M1 Band 2	Test Date	2020/7/9
-	-	Polarization	Vertical



No.	Mk.	Freq. MHz	Reading Level dBm	Correct Factor dB	Measure- ment dBm	Limit dBm	Over dB	Detector	Comment
1	*	5615.855	-15.14	0.70	-14.44	-13.00	-1.44	peak	

**REMARKS:**

(1) Measurement Value = Reading Level + Correct Factor.

(2) Margin Level = Measurement Value - Limit Value.

Test Mode	LTE Cat-M1 Band 2	Test Date	2020/7/9
-	-	Polarization	Horizontal

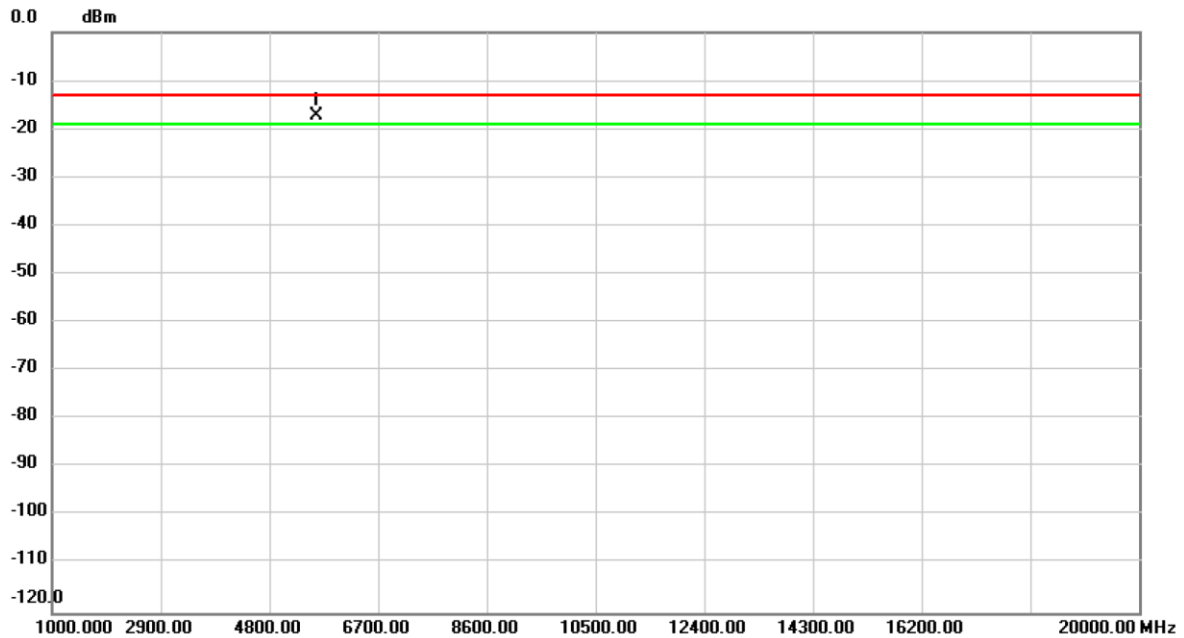

No.	Mk.	Freq.	Reading Level	Correct Factor	Measurement	Limit	Over	Detector	Comment
		MHz	dBm	dB	dBm	dBm	dB		
1	*	5615.325	-18.43	1.05	-17.38	-13.00	-4.38	peak	

**REMARKS:**

(1) Measurement Value = Reading Level + Correct Factor.

(2) Margin Level = Measurement Value - Limit Value.

## APPENDIX F - BAND EDGE

Test Mode	LTE Cat-M1 Band 2	Test Date	2020/7/24
-----------	-------------------	-----------	-----------

### LTE Cat-M1 Band 2\_5M Spectrum Plot

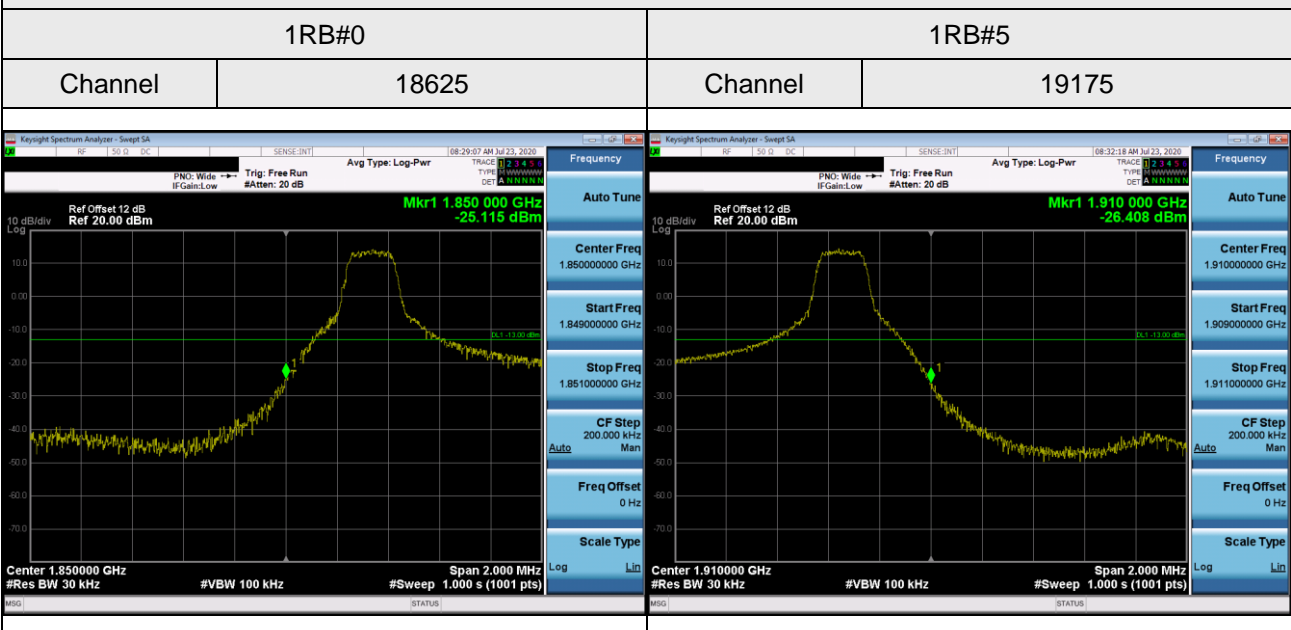

### 6RB#0

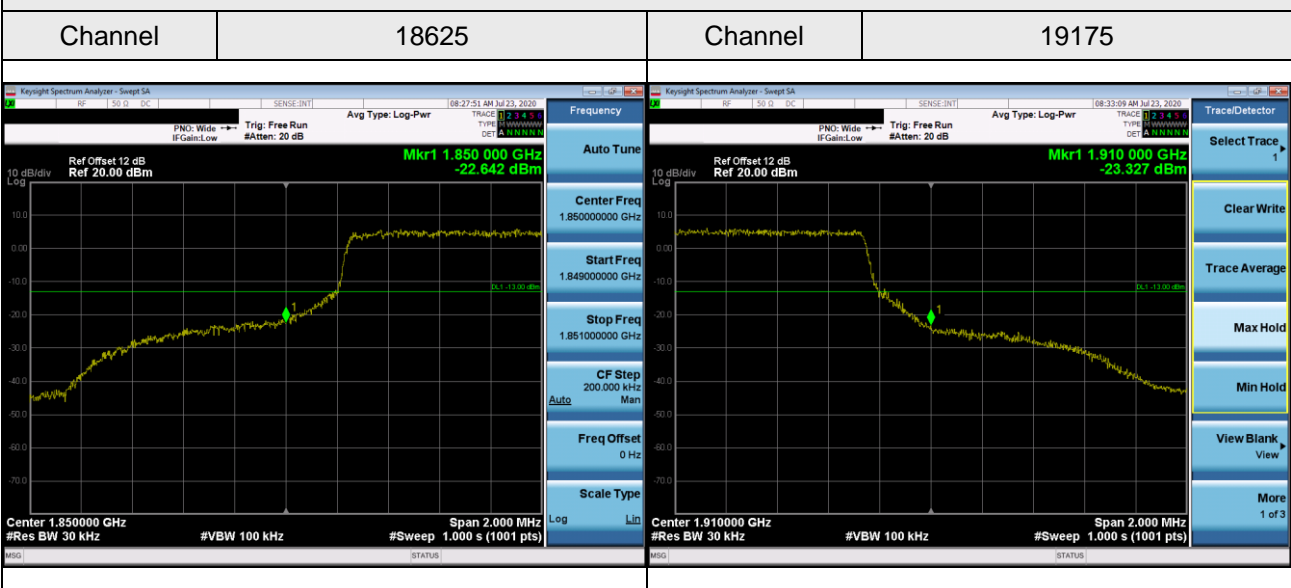

## LTE Cat-M1 Band 2\_10M Spectrum Plot

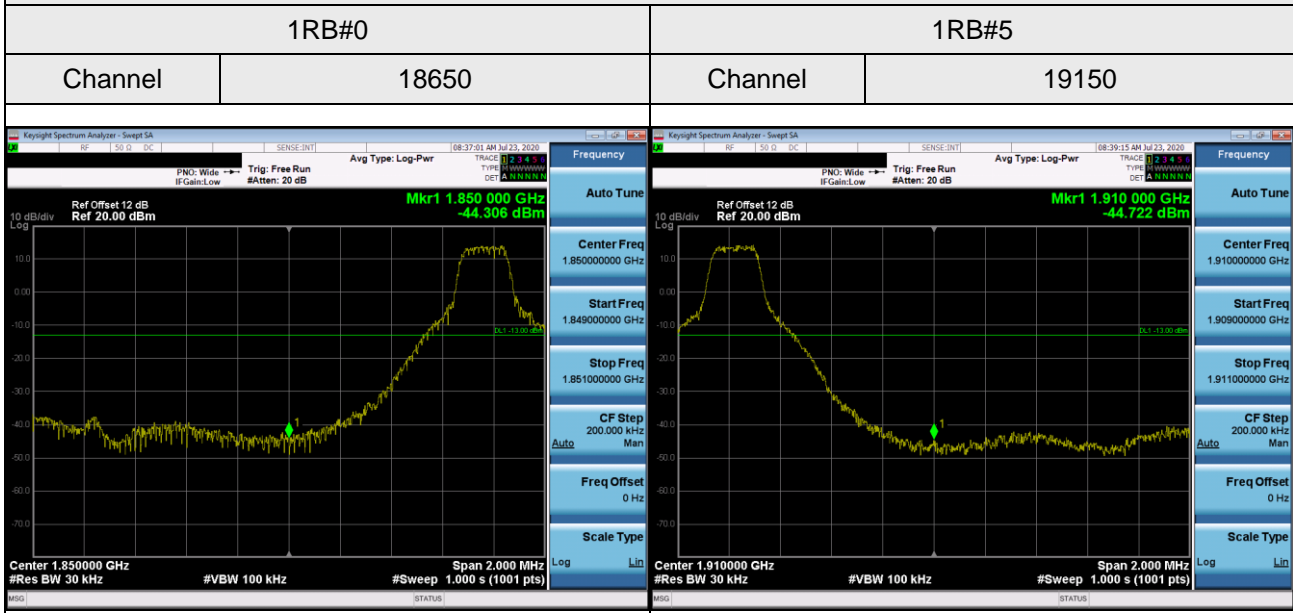

## 6RB#0

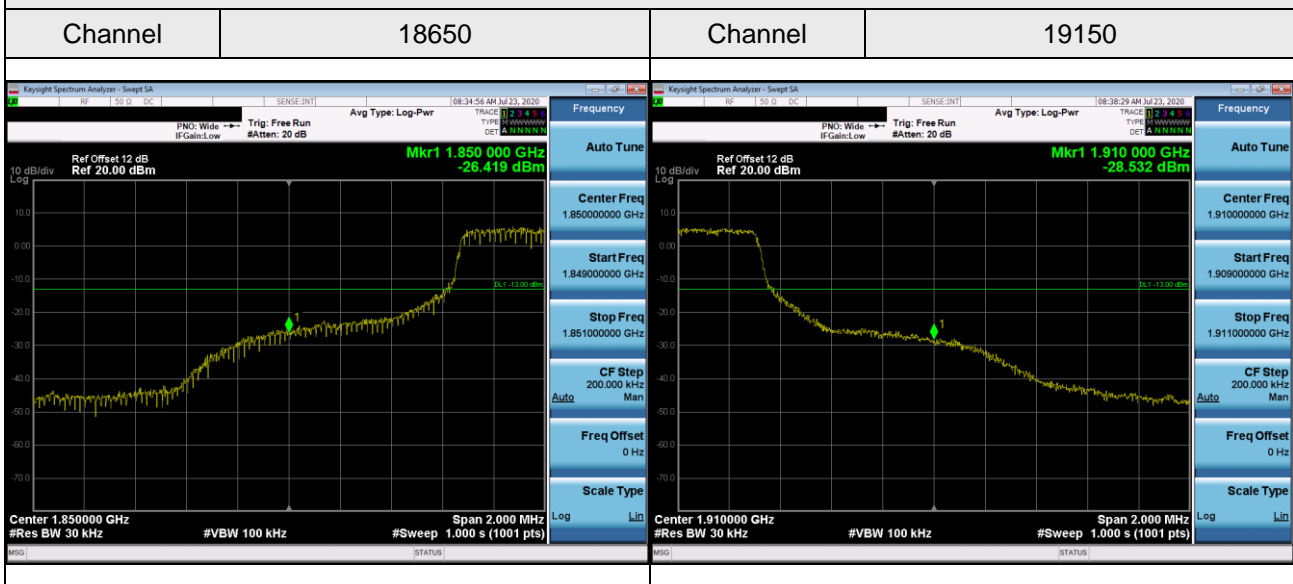

## LTE Cat-M1 Band 2\_15M Spectrum Plot

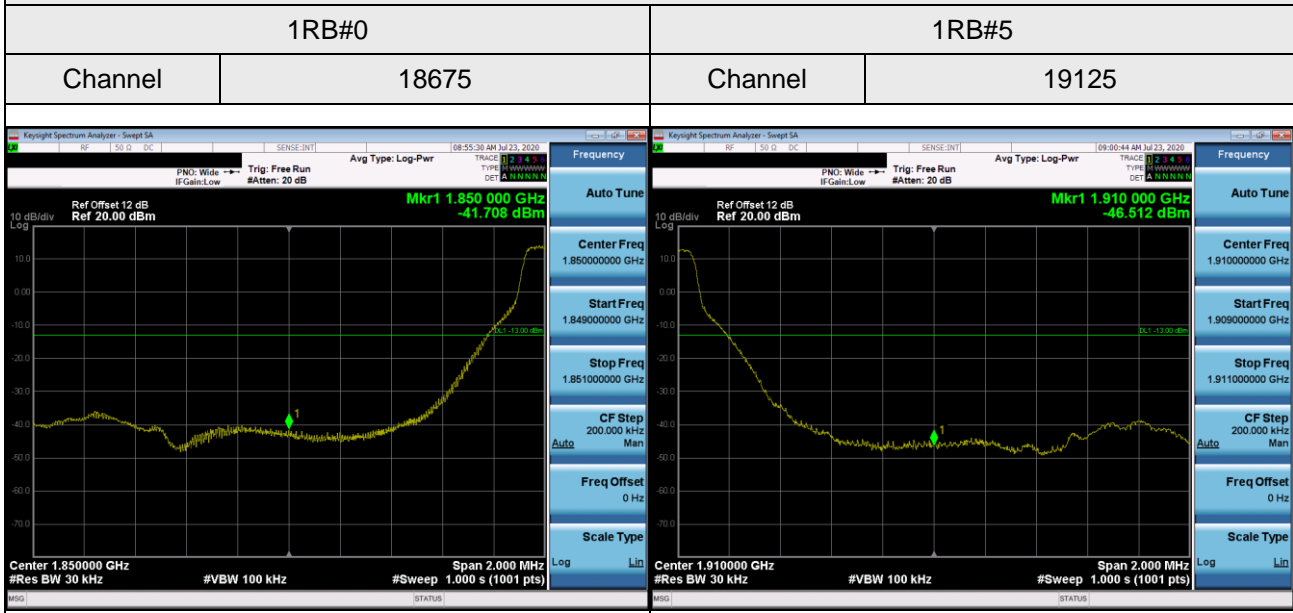

## 6RB#0

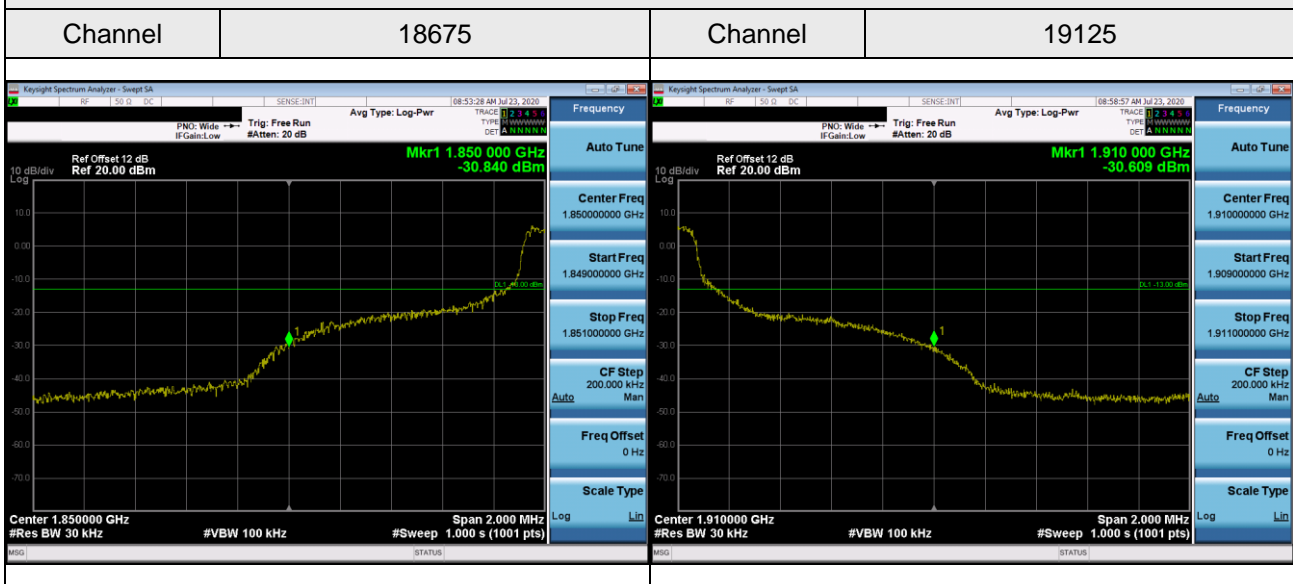

## LTE Cat-M1 Band 2\_20M Spectrum Plot

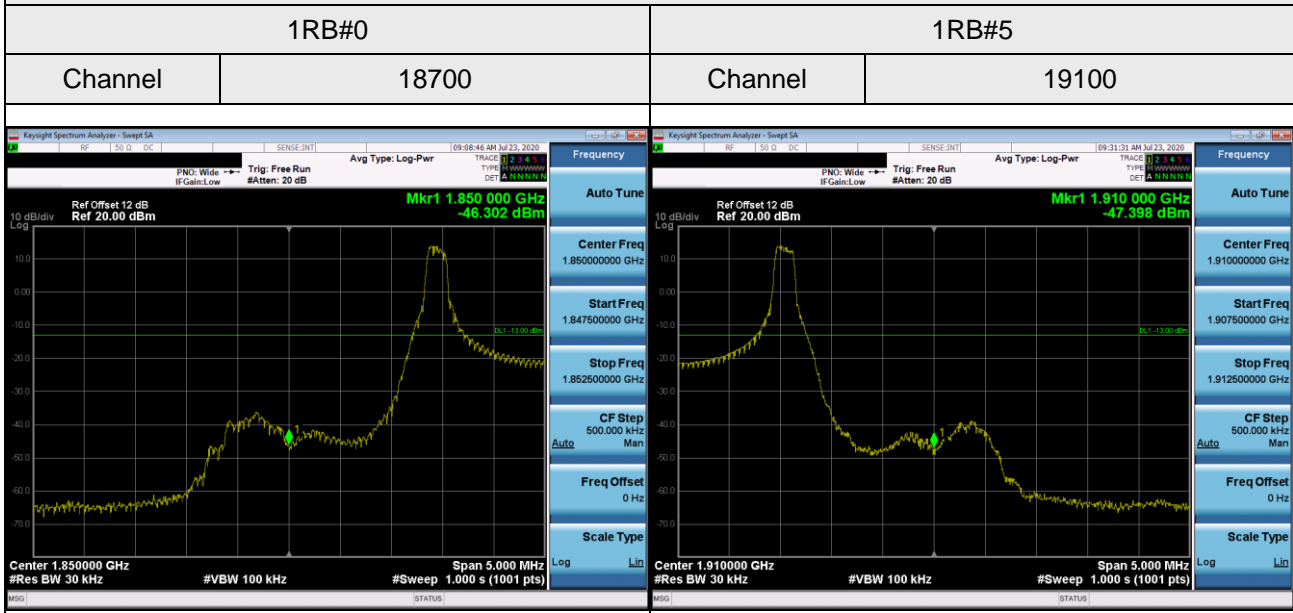

## 6RB#0

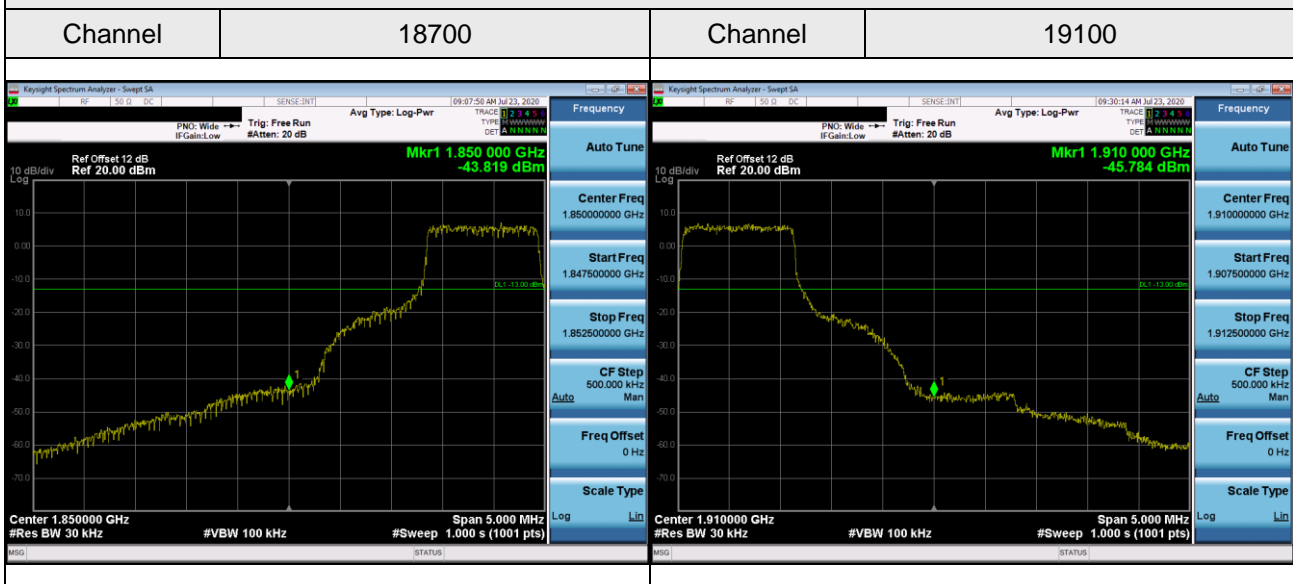

## APPENDIX G - PEAK TO AVERAGE RATIO