

Test Report

FCC Part15 Subpart E

Product Name : Integrated Gimbal Camera
Model No. : YTXJ01FM
FCC ID : 2AG53YTXJ01FM
IC : 21054-YTXJ01FM

Applicant : BEIJING FIMI TECHNOLOGY LIMITED
Address : 07C, Block A, Floor 7, No.28 Xinxi Road Jia,
Haidian District, Beijing, China

Date of Receipt : Dec. 09, 2015
Test Date : Dec. 09, 2015~ Jan. 14, 2016
Issued Date : May. 06, 2016
Report No. : 15C2019R-RF-US-P09V01
Report Version : V1.0

The test results relate only to the samples tested.

The test results shown in the test report are traceable to the national/international standard through the calibration of the equipment and evaluated measurement uncertainty herein.

This report must not be used to claim product endorsement by any agency of the government.

The test report shall not be reproduced without the written approval of Quietek Corporation.

Test Report Certification

Issued Date : May. 06, 2016
Report No. : 15C2019R-RF-US-P09V01



Product Name : Integrated Gimbal Camera
Applicant : BEIJING FIMI TECHNOLOGY LIMITED
Address : 07C, Block A, Floor 7, No.28 Xinx Road Jia, Haidian District,
Beijing, China
Manufacturer : BEIJING FIMI TECHNOLOGY LIMITED
Address : 07C, Block A, Floor 7, No.28 Xinx Road Jia, Haidian District,
Beijing, China
Model No. : YTXJ01FM
FCC ID : 2AG53YTXJ01FM
IC : 21054-YTXJ01FM
EUT Voltage : DC 15.2V
Applicable Standard : FCC CFR Title 47 Part 15 Subpart E: 2015
ANSI C63.4:2014; ANSI C63.10:2013;
789033 D02 General UNII Test Procedures New Rules v01
Industry Canada RSS-Gen Issue 4
Industry Canada RSS-247 Issue 1
Test Result : Complied
Performed Location : Quietek Corporation - Suzhou EMC Laboratory
No.99 Hongye Rd., Suzhou Industrial Park, Suzhou, 215006,
Jiangsu, China
TEL: +86-512-6251-5088 / FAX: +86-512-6251-5098
FCC Registration Number: 800392; IC Lab Code: 4075B

Documented By : Alice Ni
(Senior Adm. Specialist: Alice Ni)

Reviewed By : Frank He
(Senior Engineer: Frank He)

Approved By : Harry Zhao
(Engineering Manager : Harry Zhao)

Laboratory Information

We, **Quietek Corporation**, are an independent EMC and safety consultancy that was established the whole facility in our laboratories. The test facility has been accredited/accepted(audited or listed) by the following related bodies in compliance with ISO 17025, EN 45001 and specified testing scope:

Taiwan R.O.C.	:	BSMI, NCC, TAF
USA	:	FCC
Japan	:	VCCI
China	:	CNAS

The related certificate for our laboratories about the test site and management system can be downloaded from Quietek Corporation's Web Site : <http://www.quietek.com/english/about/certificates.aspx?bval=5>
The address and introduction of Quietek Corporation's laboratories can be founded in our Web site : http://www.quietek.com/index_en.aspx

If you have any comments, Please don't hesitate to contact us. Our contact information is as below:

HsinChu Testing Laboratory :

No.75-2, 3rd Lin, Wangye Keng, Yonghxing Tsuen, Qionglin Shiang, Hsinchu County 307, Taiwan, R.O.C.
TEL:+886-3-592-8858 / FAX:+886-3-592-8859 E-Mail : service@quietek.com

LinKou Testing Laboratory :

No.5-22, Ruishukeng, Linkou Dist., New Taipei City 24451, Taiwan, R.O.C.
TEL : 886-2-8601-3788 / FAX : 886-2-8601-3789 E-Mail : service@quietek.com

Suzhou Testing Laboratory :

No.99 Hongye Rd., Suzhou Industrial Park, Suzhou, 215006, Jiangsu, China
TEL : +86-512-6251-5088 / FAX : 86-512-6251-5098 E-Mail : service@quietek.com

TABLE OF CONTENTS

Description	Page
1. General Information	8
1.1. EUT Description.....	8
1.2. Mode of Operation	11
1.3. Tested System Details	12
1.4. Configuration of Tested System.....	13
1.5. EUT Exercise Software	14
2. Technical Test.....	15
2.1. Summary of Test Result.....	15
2.2. Test Environment	16
3. Conducted Emission.....	17
3.1. Test Equipment	17
3.2. Test Setup	17
3.3. Limit.....	18
3.4. Test Procedure	18
3.5. Uncertainty	19
3.6. Test Result	19
4. Radiated Emission	20
4.1. Test Equipment	20
4.2. Test Setup	21
4.3. Limit.....	22
4.4. Test Procedure	22
4.5. Uncertainty	24
4.6. Test Result	25
5. Occupied Bandwidth	33
5.1. Test Equipment	33
5.2. Test Setup	33
5.3. Limit.....	33

5.4.	Test Procedure	34
5.5.	Uncertainty	35
5.6.	Test Result	36
6.	6dB Occupied Bandwidth	42
6.1.	Test Equipment	42
6.2.	Test Setup	42
6.3.	Limit.....	42
6.4.	Test Procedure	43
6.5.	Uncertainty	43
6.6.	Test Result	44
7.	Power Output.....	50
7.1.	Test Equipment	50
7.2.	Test Setup	50
7.3.	Limit.....	50
7.4.	Test Procedure	52
7.5.	Uncertainty	52
7.6.	Test Result	53
8.	Peak Power Spectral Density	57
8.1.	Test Equipment	57
8.2.	Test Setup	57
8.3.	Limit.....	57
8.4.	Test Procedure	59
8.5.	Uncertainty	59
8.6.	Test Result	60
9.	Radiated Emission Band Edge.....	71
9.1.	Test Equipment	71
9.2.	Test Setup	71
9.3.	Limit.....	71
9.4.	Test Procedure	74

9.5. Uncertainty 75

9.6. Test Result 76

10. Frequency Stability..... 100

10.1. Test Equipment 100

10.2. Test Setup 100

10.3. Limit..... 100

10.4. Test Procedure 101

10.5. Uncertainty 101

10.6. Test Result 102

History of This Test Report

REPORT NO.	VERSION	DESCRIPTION	ISSUED DATE
15C2019R-RF-US-P09V01	V1.0	Initial Issued Report	May. 06, 2016

1. General Information

1.1. EUT Description

Product Name	Integrated Gimbal Camera
Model No.	YTXJ01FM
EUT Voltage	DC 15.2V
Frequency Range	For 5GHz Band 802.11a/n(20MHz): 5745~5825MHz 802.11n(40MHz): 5755~5795MHz
Channel Number	For 5GHz Band 802.11a/n(20MHz): 5 802.11n(40MHz): 2
Type of Modulation	802.11a/n: OFDM
Data Rate	802.11a: 6/9/12/18/24/36/48/54 Mbps 802.11n: up to 150 Mbps
Channel Control	Auto
Antenna Delivery	1*Tx + 2*Rx
Antenna Type	Reference to Antenna List
Peak Antenna Gain	Reference to Antenna List

Note: There are two antennas and only one antenna can transmit at the same time.

For 5.0GHz Band

802.11a Working Frequency of Each Channel:							
Channel	Frequency	Channel	Frequency	Channel	Frequency	Channel	Frequency
149	5745 MHz	153	5765 MHz	157	5785 MHz	161	5805 MHz
165	5825 MHz	N/A	N/A	N/A	N/A	N/A	N/A
802.11n(40MHz) Working Frequency of Each Channel:							
Channel	Frequency	Channel	Frequency	Channel	Frequency	Channel	Frequency
151	5755 MHz	159	5795 MHz	N/A	N/A	N/A	N/A

Antenna List

Antenna No.	Antenna	Manufacturer	Model No.	Peak Gain
Antenna 1	Internal WIFI Antenna	N/A	GY196HT337-005	3.75dBi
Antenna 2	Internal WIFI Antenna	N/A	GY196HT337-006	5.92dBi

The test mode of the test software can support.

Test Mode	Ant 1	Ant 2	Ant 1+2
802.11a	✓	✓	✗
802.11n(20MHz)	✓	✓	✗
802.11n(40MHz)	✓	✓	✗

Duty Cycle

Test Mode	Duty Cycle
802.11a	99.99 %
802.11n(20MHz)	99.99 %
802.11n(40MHz)	99.99 %

802.11a

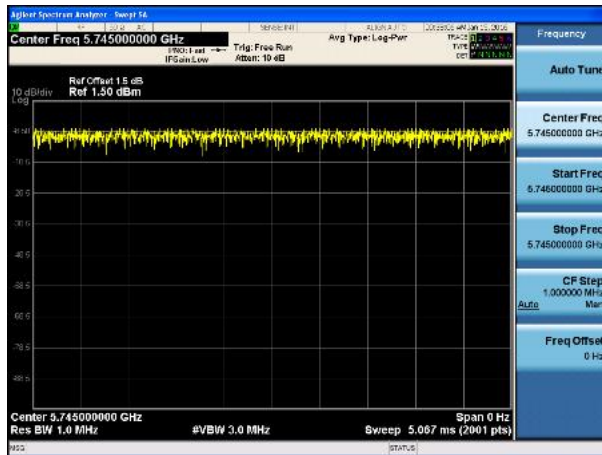

802.11n (20MHz)

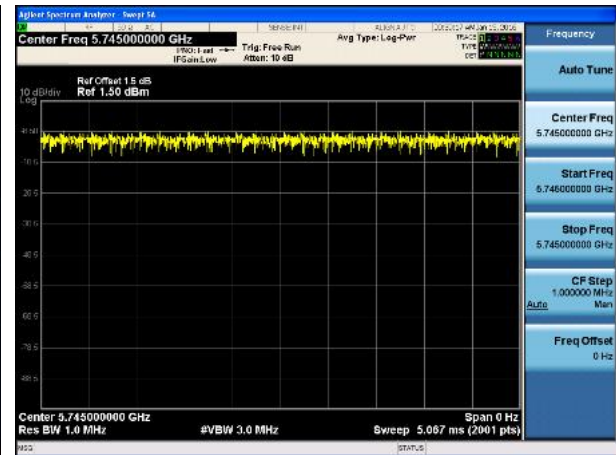

802.11n (40MHz)

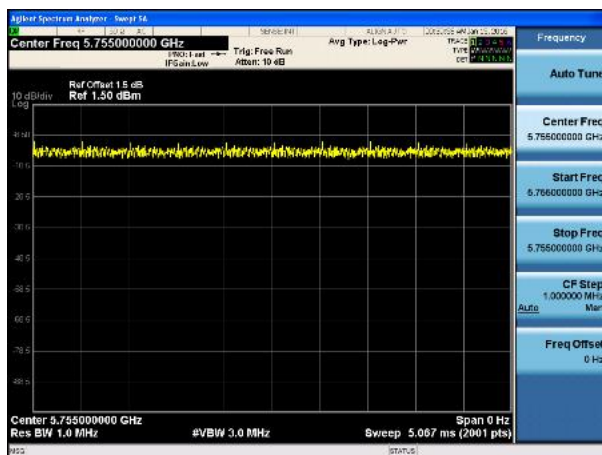

1.2. Mode of Operation

QuieTek has verified the construction and function in typical operation. All the test modes were carried out with the EUT in normal operation, which was shown in this test report and defined as:

Test Mode
Mode 1: Transmit by 802.11a
Mode 2: Transmit by 802.11n(20MHz)
Mode 3: Transmit by 802.11n(40MHz)

Note:

1. Regards to the frequency band operation: the lowest, middle and highest frequency of channel were selected to perform the test, then shown on this report.
2. The radiation measure measurements are performed in X, Y, Z axis positioning. Only the worst case is shown in the report.

1.3. Tested System Details

The types for all equipments, plus descriptions of all cables used in the tested system (including inserted cards) are:

Product		Manufacturer	Model No.	Serial No.	Power Cord
1	Notebook	Asus	N80V	8BN0AS226971468	N/A

1.4. Configuration of Tested System

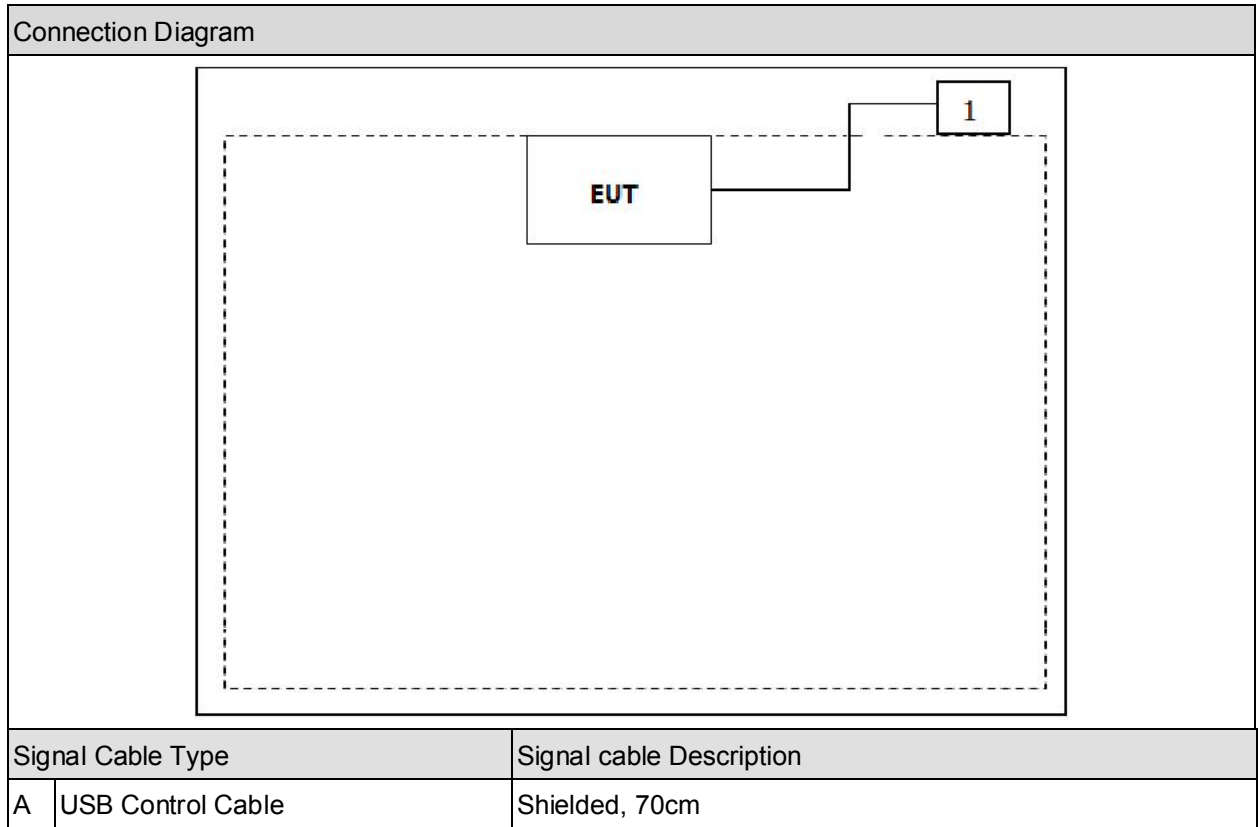

1.5. EUT Exercise Software

1	Setup the EUT and simulators as shown on above.
2	Turn on the power of equipment.
3	Input the RF commands, and set the test mode and channel, then press OK to start continue Transmit or receive.

2. Technical Test

2.1. Summary of Test Result

- No deviations from the test standards
 Deviations from the test standards as below description:

For FCC

Performed Test Item	Normative References	Test Performed	Deviation
Conducted Emission	FCC CFR Title 47 Part 15 Subpart E: 2014 Section 15.207	No	No
Radiated Emission	FCC CFR Title 47 Part 15 Subpart E: 2014 Section 15.209	Yes	No
26dB Occupied Bandwidth	FCC CFR Title 47 Part 15 Subpart E: 2014 Section 15.407(a)	Yes	No
6dB Occupied Bandwidth	FCC CFR Title 47 Part 15 Subpart E:2014 Section 15.407(e)	Yes	No
Power Output	FCC CFR Title 47 Part 15 Subpart E: 2014 Section 15.407(a)	Yes	No
Peak Power Spectral Density	FCC CFR Title 47 Part 15 Subpart E: 2014 Section 15.407(a)	Yes	No
Radiated Emission Band Edge	FCC CFR Title 47 Part 15 Subpart E: 2014 Section 15.205, 15.407(b)	Yes	No
Frequency Stability	FCC CFR Title 47 Part 15 Subpart E: 2014 Section 15.407(g)	Yes	No

For IC

Performed Test Item	Normative References	Test Performed	Deviation
Conducted Emission	RSS-Gen Issue 4 November 2014 Section 8.8	No	No
Radiated Emission	RSS-247 Issue 1 May 2015 Section 5.5	Yes	No
99% Occupied Bandwidth	RSS-Gen Issue 4 November 2014 Section 6.6	Yes	No
6dB Occupied Bandwidth	RSS-247 Issue 1 May 2015 Section 6.2	Yes	No
Power Output	RSS-247 Issue 1 May 2015 Section 6.2	Yes	No
Peak Power Spectral Density	RSS-247 Issue 1 May 2015 Section 6.2	Yes	No
Radiated Emission Band Edge	RSS-Gen Issue 4 November 2014 Section 8.10	Yes	No
Frequency Stability	RSS-Gen Issue 4 November 2014 Section 8.11	Yes	No

Note: The EUT is powered by battery, so conducted emission is not tested.

2.2. Test Environment

Items	Required (IEC 68-1)	Actual
Temperature (°C)	15-35	21
Humidity (%RH)	25-75	50
Barometric pressure (mbar)	860-1060	950-1000

3. Conducted Emission

3.1. Test Equipment

Conducted Emission / TR-1

Instrument	Manufacturer	Type No.	Serial No.	Cal. Due Date
EMI Test Receiver	R&S	ESCI	100726	2016.03.28
Two-Line V-Network	R&S	ENV216	100043	2016.03.28
Two-Line V-Network	R&S	ENV216	100044	2016.09.16
50ohm Coaxial Switch	Anritsu	MP59B	6200464462	2016.03.01
50ohm Termination	SHX	TF2	07081401	2016.09.16
Temperature/Humidity Meter	zhicheng	ZC1-2	TR1-TH	2017.01.04

Note: All equipments are calibrated with traceable calibrations. Each calibration is traceable to the national or international standards.

3.2. Test Setup

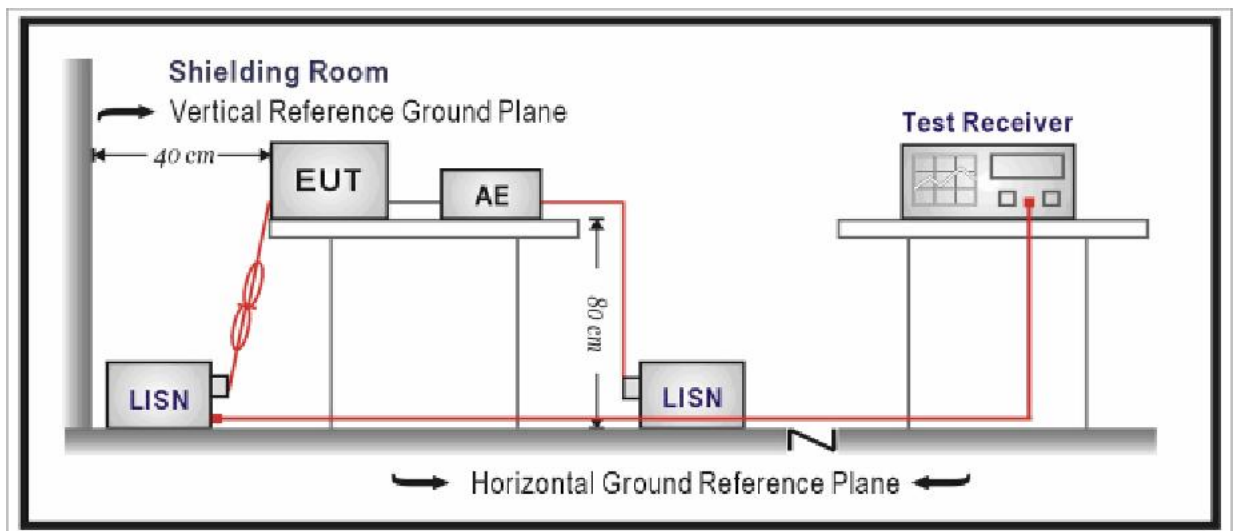

3.3. Limit

For FCC&IC

FCC Part 15 Subpart C Paragraph 15.207 Limits		
Frequency (MHz)	QP (dBuV)	AV (dBuV)
0.15 - 0.50	66 - 56	56 - 46
0.50 - 5.0	56	46
5.0 - 30	60	50

Note 1: The lower limit shall apply at the transition frequencies.

Note 2: The limit decreases linearly with the logarithm of the frequency in the range 0.15 MHz to 0.5 MHz.

3.4. Test Procedure

according to ANSI C63.4:2014& ANSI C63.10:2013&789033 D02 General UNII Test Procedures New Rules v01& FCC CFR Title 47 Part 15 Subpart E: 2014& Industry Canada RSS-Gen Issue 4 Industry Canada RSS-247 Issue 1

The EUT was placed on a platform of nominal size, 1 m by 1.5 m, raised 80 cm above the conducting ground plane. The vertical conducting plane was located 40 cm to the rear of the EUT. All other surfaces of EUT were at least 80 cm from any other grounded conducting surface. The EUT and simulators are connected to the main power through a line impedance stabilization network (LISN). The LISN provides a 50 ohm /50uH coupling impedance for the measuring equipment. The peripheral devices are also connected to the main power through a LISN. (Please refer to the block diagram of the test setup and photographs)

Each current-carrying conductor of the EUT power cord, except the ground (safety) conductor, was individually connected through a LISN to the input power source.

The excess length of the power cord between the EUT and the LISN receptacle were folded back and forth at the center of the lead to form a bundle not exceeding 40 cm in length.

Conducted emissions were investigated over the frequency range from 0.15MHz to 30MHz using a receiver bandwidth of 9kHz.

3.5. Uncertainty

The measurement uncertainty is defined as ± 2.02 dB

3.6. Test Result

The device was powered by battery, so the test is not applied.

4. Radiated Emission

4.1. Test Equipment

Radiated Emission / AC-2

Instrument	Manufacturer	Type No.	Serial No.	Cal. Due Date
EMI Test Receiver	R&S	ESCI	100573	2016.03.28
Loop Antenna	R&S	HFH2-Z2	833799/003	2016.11.17
Bilog Chainenna	Teseq GmbH	CBL6112D	27611	2016.10.15
Coaxial Cable	Huber+Suhner	SUCOFLEX 106	AC2-C	2016.03.01
Temperature/Humidity Meter	Zhicheng	ZC1-2	AC2-TH	2017.01.04

Radiated Emission / AC-5

Instrument	Manufacturer	Type No.	Serial No.	Cal. Due Date
Spectrum Analyzer	Agilent	N9020A	MY49100159	2016.03.28
Spectrum Analyzer	Agilent	E4446A	MY45300103	2017.01.04
Preamplifier	Miteq	NSP1800-25	1364185	2016.05.05
Preamplifier	QuieTek	AP-040G	CHM-0906001	2016.05.05
DRG Horn	ETS-Lindgren	3117	00123988	2016.01.21
Broad-Band Horn Antenna	Schwarzbeck	BBHA9170	294	2016.11.24
Coaxial Cable	Huber+Suhner	SUCOFLEX 106	AC5-C1	2016.03.01
Coaxial Cable	Huber+Suhner	SUCOFLEX 106	AC5-C2	2016.03.01
Coaxial Cable	Huber+Suhner	SUCOFLEX 102	AC5-C3	2016.03.01
EMI Receiver	Agilent	N9038A	MY51210196	2016.06.09
Temperature/Humidity Meter	Zhichen	ZC1-2	AC5-TH	2017.01.04

Note 1: All equipments are calibrated with traceable calibrations. Each calibration is traceable to the national or international standards.

4.2. Test Setup

For FCC&IC

Below 30MHz Test Setup:

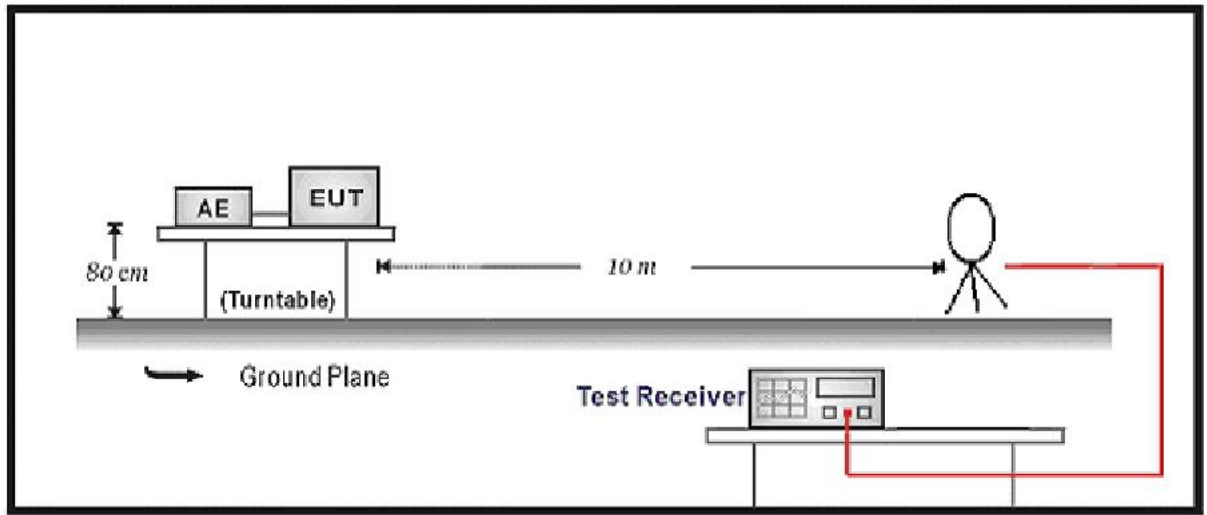

Below 1GHz Test Setup:

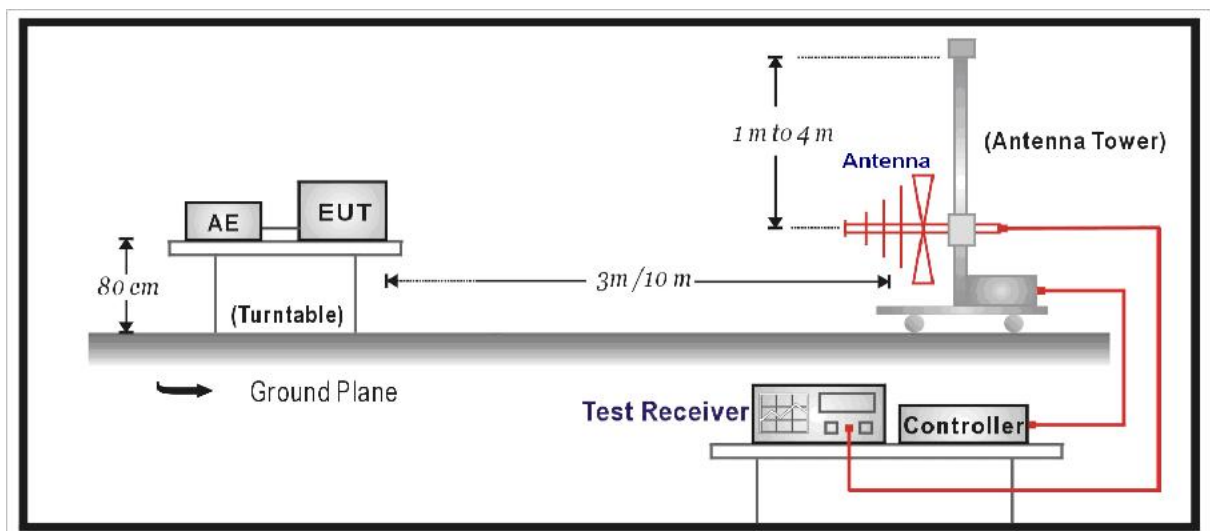

Above 1GHz Test Setup:

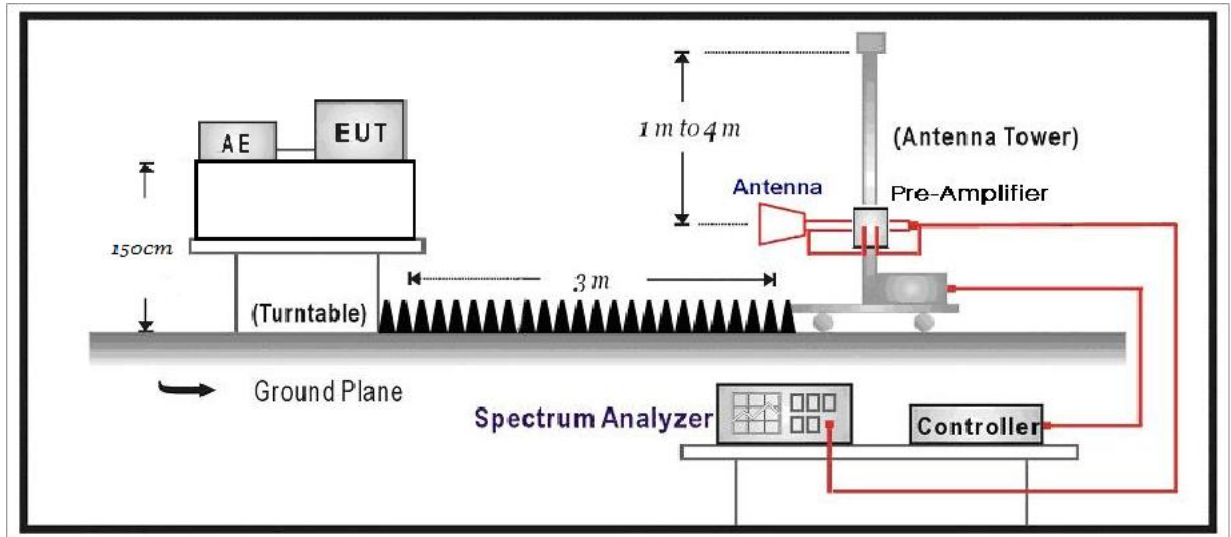

4.3. Limit

FCC Part 15 Subpart C Paragraph 15.209		
Frequency (MHz)	Distance (m)	Level (dBuV/m)
30 - 88	3	40
88 - 216	3	43.5
216 - 960	3	46
Above 960	3	54

Note 1: The lower limit shall apply at the transition frequency.

Note 2: Distance refers to the distance in meters between the measuring instrument Chainenna and the closed point of any part of the device or system.

Note 3: E field strength (dBuV/m) = $20 \log E$ field strength (uV/m)

4.4. Test Procedure

According to ANSI C63.4:2014& ANSI C63.10:2013&789033 D02 General UNII Test Procedures New Rules v01& FCC CFR Title 47 Part 15 Subpart E: 2014& Industry Canada RSS-Gen Issue 4 Industry Canada RSS-247 Issue 1

The EUT is placed on a turn table which is 0.8 meter above ground for below 1GHz, and the EUT is placed on a turn table which is 1.5 meter above ground for above 1GHz. The turn table

is rotated 360 degrees to determine the position of the maximum emission level. The EUT was positioned such that the distance from Chainenna to the EUT was 3 meters.

The Chainenna is scanned from 1 meter to 4 meters to find out the maximum emission level. This is repeated for both horizontal and vertical polarization of the Chainenna. In order to find the maximum emission, all of the interface cables were manipulated according to ANSI C63.4:2014 on radiated measurement.

The resolution bandwidth below 1GHz setting on the field strength meter is 120 kHz and above 1GHz is 1MHz.

The frequency range from 30MHz to 10th harmonic is checked.

The procedure for peak unwanted emissions measurements above 1000 MHz is as follows:

Peak emission levels are measured by setting the instrument as follows:

- 1) RBW = 1 MHz.
- 2) VBW \geq [3 \times RBW].
- 3) Detector = peak
- 4) Sweep time = auto.
- 5) Trace mode = max hold.
- 6) Allow sweeps to continue until the trace stabilizes. Note that if the transmission is not continuous, then the time required for the trace to stabilize will increase by a factor of approximately 1 / D, where D is the duty cycle. For example, at 50% duty cycle, the measurement time will increase by a factor of two, relative to measurement time for continuous transmission.

Average emission levels are measured by setting the instrument as follows:

- a) RBW = 1 MHz.
- b) Video bandwidth:
 - 1) If the EUT is configured to transmit with $D \geq 98\%$, then set $VBW \leq RBW / 100$ (i.e., 10 kHz), but not less than 10 Hz.
 - 2) If the EUT D is $< 98\%$, then set $VBW \geq 1 / T$, where T is defined in item a1) of 12.2.
- c) Video bandwidth mode or display mode:
 - 1) The instrument shall be set with video filtering applied in the power domain. Typically, this requires setting the detector mode to RMS (power averaging) and setting the average-VBW type to power (rms).
 - 2) As an alternative, the instrument may be set to linear detector mode. Video filtering shall be applied in linear voltage domain (rather than in a log or dB domain). Some instruments require linear display mode to accomplish this. Others have a setting for average-VBW type, which can be set to "voltage" regardless of the display mode.
- d) Detector = peak.

- e) Sweep time = auto.
- f) Trace mode = max hold.
- g) Allow max hold to run for at least 50 traces if the transmitted signal is continuous or has at least 98% duty cycle. For lower duty cycles, increase the minimum number of traces by a factor of $1/x$, where D is the duty cycle. For example, use at least 200 traces if the duty cycle is 25%. (If a specific emission is demonstrated to be continuous—i.e., 100% duty cycle—then rather than turning ON and OFF with the transmit cycle, at least 50 traces should be averaged.)

Note: When doing emission measurement above 1GHz, the horn Chainenna will be bended down a little (as horn antenna has the narrow beamwidth) in order to keeping the Chainenna in the “cone of radiation” of EUT. The 3dB beamwidth is 60~10 degrees for H-plane and 90~10 degrees for E-plane.

4.5. Uncertainty

The measurement uncertainty above 1GHz is defined as ± 3.9 dB
below 1GHz is defined as ± 3.8 dB

4.6. Test Result

Mode1: Transmit by 802.11a

Chain	CH	Antenna	Frequency (MHz)	Reading Level (dBuV/m)	Factor (dB)	Measure Level (dBuV/m)	Limit (dBuV/m)	Margin (dB)	Detector
Ant 1	149	H	11490.0	25.05	21.7	46.75	54(Note3)	-7.25	PK
		H	17235.0	20.42	26.1	46.52	54(Note3)	-7.48	PK
		V	11490.0	28.75	21.7	50.45	54(Note3)	-3.55	PK
		V	17235.0	26.41	26.1	52.51	54(Note3)	-2.49	PK
	157	H	11570.0	25.70	22.4	48.10	54(Note3)	-5.90	PK
		H	17355.0	14.97	25.8	40.77	54(Note3)	-13.23	PK
		V	11570.0	26.30	22.4	48.70	54(Note3)	-5.30	PK
		V	17355.0	16.28	25.8	42.08	54(Note3)	-11.92	PK
	165	H	11650.0	23.98	23.2	47.18	54(Note3)	-6.82	PK
		H	17475.0	21.66	25.9	47.56	54(Note3)	-6.44	PK
		V	11650.0	26.14	23.2	49.34	54(Note3)	-4.66	PK
		V	17475.0	23.84	25.9	49.74	54(Note3)	-4.26	PK

Chain	CH	Antenna	Frequency (MHz)	Reading Level (dBuV/m)	Factor (dB)	Measure Level (dBuV/m)	Limit (dBuV/m)	Margin (dB)	Detector
Ant 2	149	H	11490.0	25.77	21.7	47.47	54(Note3)	-6.53	PK
		H	17235.0	21.13	26.1	47.23	54(Note3)	-6.77	PK
		V	11490.0	28.93	21.7	50.63	54(Note3)	-3.37	PK
		V	17235.0	27.09	26.1	53.19	54(Note3)	-1.81	PK
	157	H	11570.0	26.02	22.4	48.42	54(Note3)	-5.58	PK
		H	17355.0	15.01	25.8	40.81	54(Note3)	-13.19	PK
		V	11570.0	26.54	22.4	48.94	54(Note3)	-5.06	PK
		V	17355.0	16.39	25.8	42.19	54(Note3)	-11.81	PK
	165	H	11650.0	24.18	23.2	47.38	54(Note3)	-6.62	PK
		H	17475.0	21.67	25.9	47.57	54(Note3)	-6.43	PK
		V	11650.0	26.88	23.2	50.08	54(Note3)	-3.92	PK
		V	17475.0	24.01	25.9	49.91	54(Note3)	-4.09	PK

Note: 1. Measure Level = Reading Level + Factor.

2. The test frequency range, 9kHz~30MHz, 18GHz~25GHz, both of the worst case are at least 6dB below the limits, therefore no data appear in the report.
3. This limit applies for using average detector, if the test result on peak is lower than average limit, then average measurement needn't be performed.

Mode2: Transmit by 802.11n(20MHz)

Chain	CH	Antenna	Frequency (MHz)	Reading Level (dBuV/m)	Factor (dB)	Measure Level (dBuV/m)	Limit (dBuV/m)	Margin (dB)	Detector
Ant 1	149	H	11490.0	24.54	21.7	46.24	54(Note3)	-7.76	PK
		H	17235.0	20.65	26.1	46.75	54(Note3)	-7.25	PK
		V	11490.0	27.85	21.7	49.55	54(Note3)	-4.45	PK
		V	17235.0	25.52	26.1	51.62	54(Note3)	-3.38	PK
	157	H	11570.0	24.96	22.4	47.36	54(Note3)	-6.64	PK
		H	17355.0	16.65	25.8	42.45	54(Note3)	-11.55	PK
		V	11570.0	24.47	22.4	46.87	54(Note3)	-7.13	PK
		V	17355.0	15.86	25.8	41.66	54(Note3)	-12.34	PK
	165	H	11650.0	24.12	23.2	47.32	54(Note3)	-6.68	PK
		H	17475.0	21.91	25.9	47.81	54(Note3)	-6.19	PK
		V	11650.0	26.01	23.2	49.21	54(Note3)	-4.79	PK
		V	17475.0	23.34	25.9	49.24	54(Note3)	-4.76	PK

Chain	CH	Antenna	Frequency (MHz)	Reading Level (dBuV/m)	Factor (dB)	Measure Level (dBuV/m)	Limit (dBuV/m)	Margin (dB)	Detector
Ant 2	149	H	11490.0	25.08	21.7	46.78	54(Note3)	-7.22	PK
		H	17235.0	20.99	26.1	47.09	54(Note3)	-6.91	PK
		V	11490.0	27.57	21.7	49.27	54(Note3)	-4.73	PK
		V	17235.0	25.71	26.1	51.81	54(Note3)	-2.19	PK
	157	H	11570.0	25.16	22.4	47.56	54(Note3)	-6.44	PK
		H	17355.0	16.79	25.8	42.59	54(Note3)	-11.41	PK
		V	11570.0	25.15	22.4	47.55	54(Note3)	-6.45	PK
		V	17355.0	16.69	25.8	42.49	54(Note3)	-11.51	PK
	165	H	11650.0	24.55	23.2	47.75	54(Note3)	-6.25	PK
		H	17475.0	22.13	25.9	48.03	54(Note3)	-5.97	PK
		V	11650.0	25.84	23.2	49.04	54(Note3)	-4.96	PK
		V	17475.0	24.10	25.9	50.00	54(Note3)	-4.00	PK

Note: 1. Measure Level = Reading Level + Factor.

2. The test frequency range, 9kHz~30MHz, 18GHz~25GHz, both of the worst case are at least 6dB below the limits, therefore no data appear in the report.
3. This limit applies for using average detector, if the test result on peak is lower than average limit, then average measurement needn't be performed.

Mode3: Transmit by 802.11n(40MHz)

Chain	CH	Antenna	Frequency (MHz)	Reading Level (dBuV/m)	Factor (dB)	Measure Level (dBuV/m)	Limit (dBuV/m)	Margin (dB)	Detector
Ant 1	151	H	11510.0	24.35	21.9	46.25	54(Note3)	-7.75	PK
		H	17265.0	20.52	26.3	46.82	54(Note3)	-7.18	PK
		V	11510.0	26.95	21.9	48.85	54(Note3)	-5.15	PK
		V	17265.0	24.76	26.3	51.06	54(Note3)	-2.94	PK
	159	H	11590.0	24.37	23.0	47.37	54(Note3)	-6.63	PK
		H	17385.0	16.42	25.8	42.22	54(Note3)	-11.78	PK
		V	11590.0	24.28	22.4	46.68	54(Note3)	-7.32	PK
		V	17385.0	16.00	25.8	41.80	54(Note3)	-12.20	PK

Chain	CH	Antenna	Frequency (MHz)	Reading Level (dBuV/m)	Factor (dB)	Measure Level (dBuV/m)	Limit (dBuV/m)	Margin (dB)	Detector
Ant 2	151	H	11510.0	23.43	21.9	45.33	54(Note3)	-8.67	PK
		H	17265.0	19.65	26.3	45.95	54(Note3)	-8.05	PK
		V	11510.0	26.17	21.9	48.07	54(Note3)	-5.93	PK
		V	17265.0	24.05	26.3	50.35	54(Note3)	-3.65	PK
	159	H	11590.0	23.54	23.0	46.54	54(Note3)	-7.46	PK
		H	17385.0	15.63	25.8	41.43	54(Note3)	-12.57	PK
		V	11590.0	23.15	22.4	45.55	54(Note3)	-8.45	PK
		V	17385.0	15.53	25.8	41.33	54(Note3)	-12.67	PK

- Note: 1. Measure Level = Reading Level + Factor.
2. The test frequency range, 9kHz~30MHz, 18GHz~25GHz, both of the worst case are at least 6dB below the limits, therefore no data appear in the report.
3. This limit applies for using average detector, if the test result on peak is lower than average limit, then average measurement needn't be performed.

The worst case of Radiated Emission below 1GHz:

Engineer: Scott	
Site: AC2	Time: 2015/12/05 - 09:57
Limit: FCC_Part15.209_RE(3m)_ClassB	Margin: 0
Probe: CB7_CBL6112_0726	Polarity: Horizontal
EUT: Integrated Gimbal Camera	Power: By Battery
Note: Mode 1	

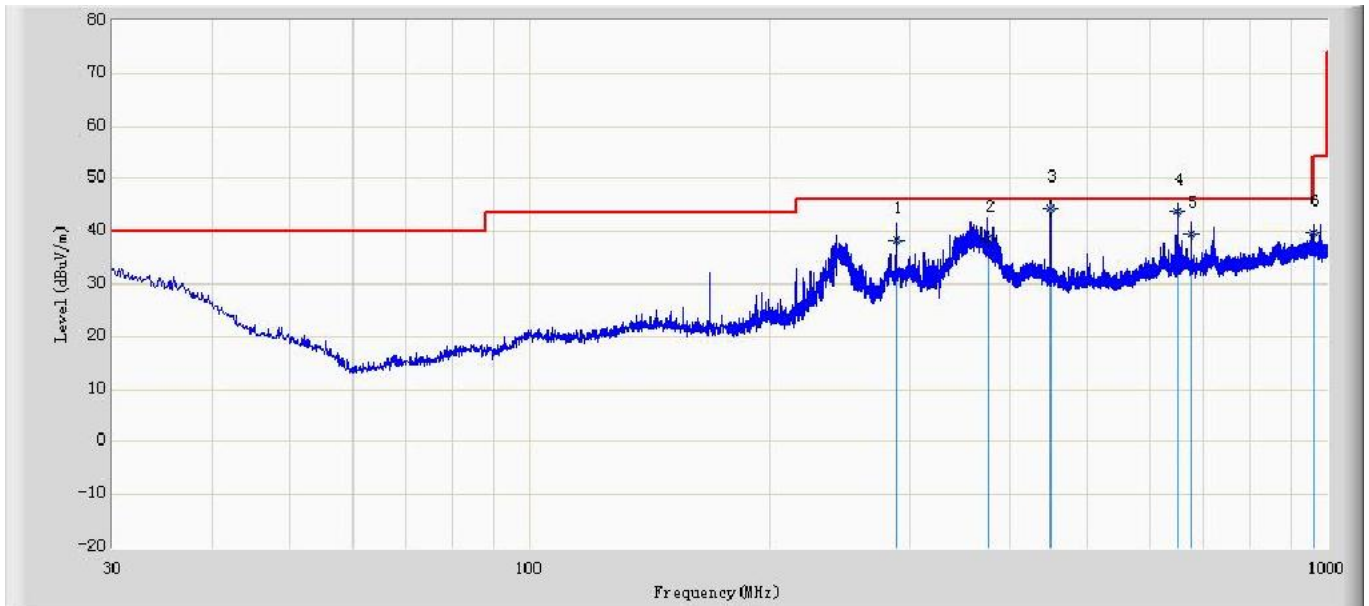

No	Mark	Frequency (MHz)	Measure Level (dBuV/m)	Reading Level (dBuV)	Over Limit (dB)	Limit (dBuV/m)	Factor (dB)	Type
1		288.610	38.362	46.504	-7.638	46.000	-8.142	QP
2		375.860	38.681	44.184	-7.319	46.000	-5.503	QP
3	*	450.014	44.374	47.834	-1.626	46.000	-3.460	QP
4		648.026	43.746	44.225	-2.254	46.000	-0.479	QP
5		676.330	39.349	39.915	-6.651	46.000	-0.566	QP
6		960.203	39.822	37.710	-14.178	54.000	2.112	QP

Engineer: Scott	
Site: AC2	Time: 2015/12/05 - 09:57
Limit: FCC_Part15.209_RE(3m)_ClassB	Margin: 0
Probe: CB7_CBL6112_0726	Polarity: Vertical
EUT: Integrated Gimbal Camera	Power: By Battery
Note: Mode 1	

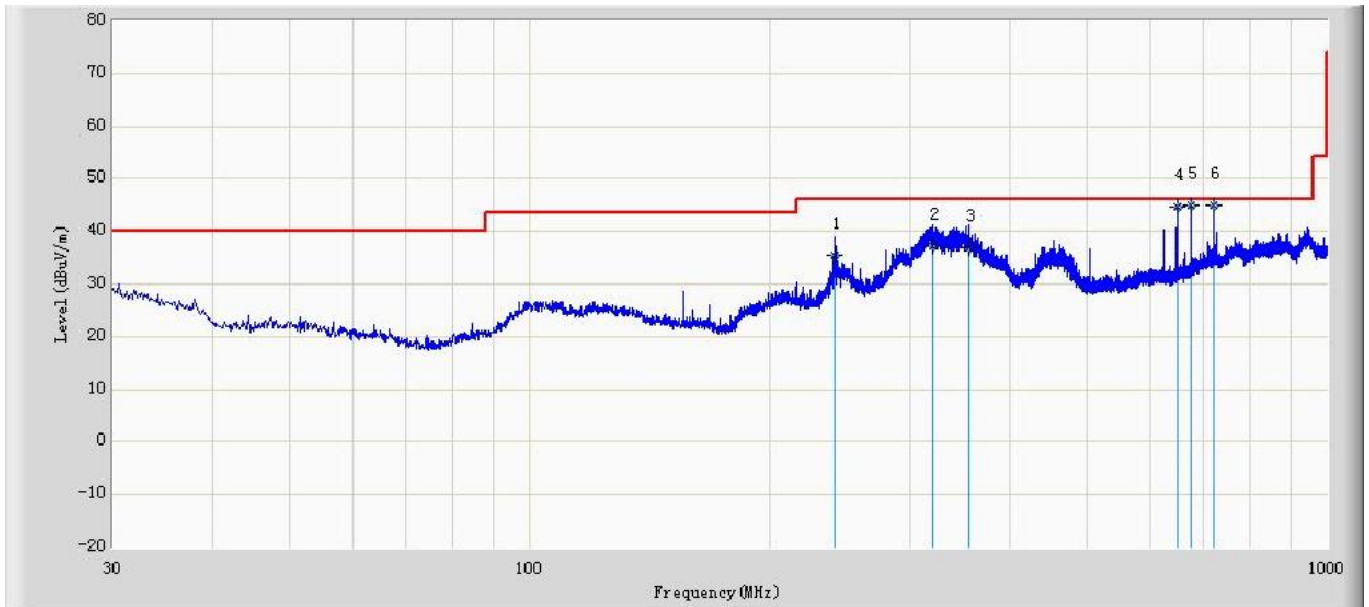

No	Mark	Frequency (MHz)	Measure Level (dBuV/m)	Reading Level (dBuV)	Over Limit (dB)	Limit (dBuV/m)	Factor (dB)	Type
1		241.330	35.360	45.343	-10.640	46.000	-9.983	QP
2		320.160	37.091	44.195	-8.909	46.000	-7.104	QP
3		355.263	36.924	43.010	-9.076	46.000	-6.086	QP
4		648.037	44.763	45.241	-1.237	46.000	-0.478	QP
5		676.034	44.897	45.459	-1.103	46.000	-0.562	QP
6	*	720.035	44.993	45.338	-1.007	46.000	-0.345	QP

5. Occupied Bandwidth

5.1. Test Equipment

Occupied Bandwidth / TR-8

Instrument	Manufacturer	Type No.	Serial No.	Cal. Due Date
Spectrum Analyzer	Agilent	N9010A	MY48030494	2016.03.10
Temperature/Humidity Meter	zhicheng	ZC1-2	TR8-TH	2016.04.09

Note: All equipments are calibrated with traceable calibrations. Each calibration is traceable to the national or international standards.

5.2. Test Setup

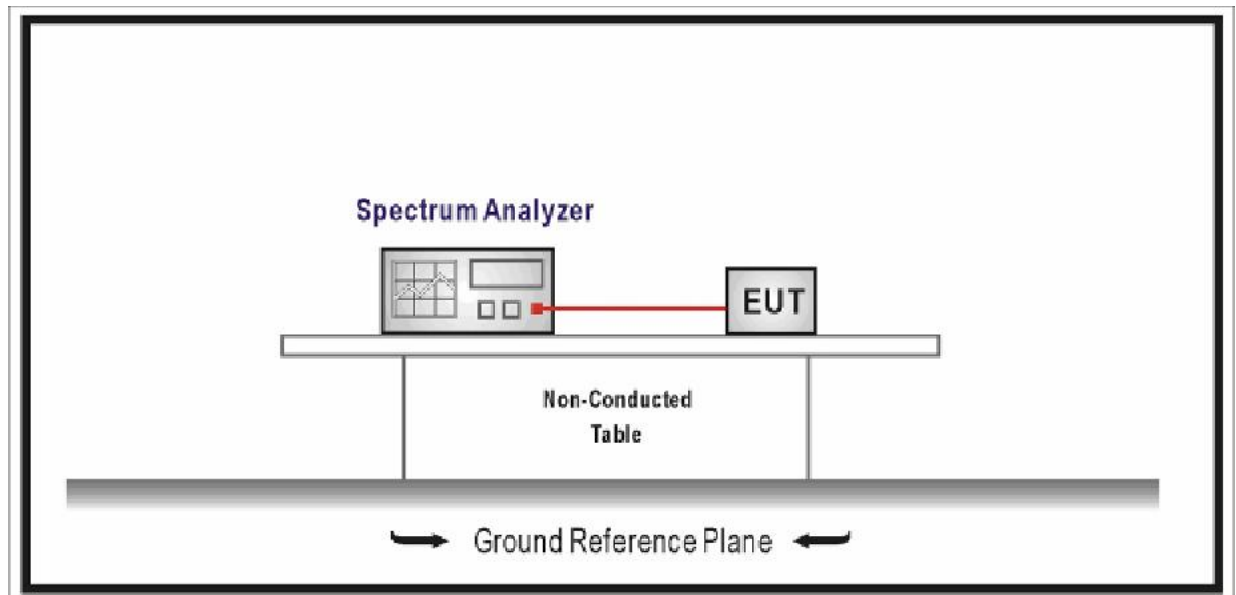

5.3. Limit

N/A

5.4. Test Procedure

According to ANSI C63.4:2014& ANSI C63.10:2013&789033 D02 General UNII Test Procedures New Rules v01& FCC CFR Title 47 Part 15 Subpart E: 2014& Industry Canada RSS-Gen Issue 4 Industry Canada RSS-247 Issue 1

Emission Bandwidth

- a) Set RBW = approximately 1% of the emission bandwidth.
- b) Set the VBW > RBW.
- c) Detector = Peak.
- d) Trace mode = max hold.
- e) Measure the maximum width of the emission that is 26 dB down from the maximum of the emission. Compare this with the RBW setting of the analyzer. Readjust RBW and repeat measurement as needed until the RBW/EBW ratio is approximately 1%.

99% Occupied Bandwidth

- a) The instrument center frequency is set to the nominal EUT channel center frequency. The frequency span for the spectrum analyzer shall be between 1.5 times and 5.0 times the OBW.
- b) The nominal IF filter bandwidth (3 dB RBW) shall be in the range of 1% to 5% of the OBW, and VBW shall be approximately three times the RBW, unless otherwise specified by the applicable requirement.
- c) Set the reference level of the instrument as required, keeping the signal from exceeding the maximum input mixer level for linear operation. In general, the peak of the spectral envelope shall be more than $[10 \log (OBW/RBW)]$ below the reference level. Specific guidance is given in 4.1.5.2.
- d) Step a) through step c) might require iteration to adjust within the specified range.
- e) Video averaging is not permitted. Where practical, a sample detection and single sweep mode shall be used. Otherwise, peak detection and max hold mode (until the trace stabilizes) shall be used.
- f) Use the 99% power bandwidth function of the instrument (if available) and report the measured bandwidth.
- g) If the instrument does not have a 99% power bandwidth function, then the trace data points are recovered and directly summed in linear power terms. The recovered amplitude data points, beginning at the lowest frequency, are placed in a running sum until 0.5% of the total is reached; that frequency is recorded as the lower frequency. The process is repeated until 99.5% of the total is reached; that frequency is recorded as the upper frequency. The 99% power bandwidth is the difference between these two frequencies.
- h) The occupied bandwidth shall be reported by providing plot(s) of the measuring instrument display; the plot axes and the scale units per division shall be clearly labeled. Tabular data may be reported in addition to the plot(s).

5.5. Uncertainty

The measurement uncertainty is defined as ± 1 kHz

5.6. Test Result

Product	:	INTEGRATED GIMBAL CAMERA
Test Item	:	Occupied Bandwidth
Test Site	:	TR-8
Test Mode	:	Mode 1: Transmit by 802.11a

Channel No.	Frequency (MHz)	99% Occupied Bandwidth (MHz)	26dB Occupied Bandwidth (MHz)
149	5745	16.486	21.16
157	5785	16.471	20.94
165	5825	16.460	20.61

Channel 149 (5745MHz)



Channel 157(5785MHz)

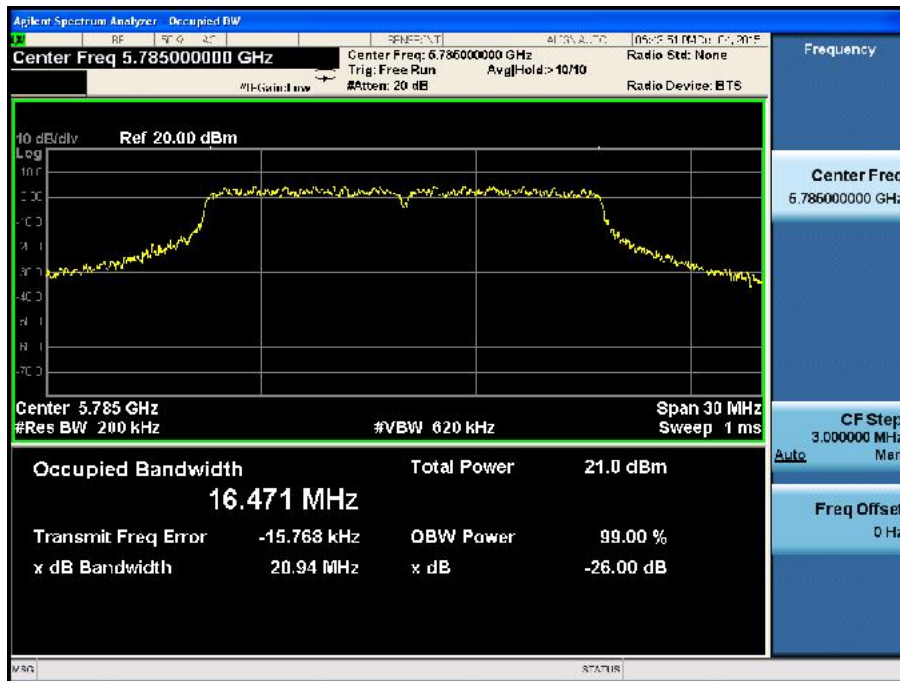

Channel 165 (5825MHz)



Note: For this test item, the modulation of this mode we have evaluated two antennas, presented data in the report is the worst case.

Product	:	INTEGRATED GIMBAL CAMERA
Test Item	:	Occupied Bandwidth
Test Site	:	TR-8
Test Mode	:	Mode 2: Transmit by 802.11n(20MHz)

Channel No.	Frequency (MHz)	99% Occupied Bandwidth (MHz)	26dB Occupied Bandwidth (MHz)
149	5745	17.676	22.34
157	5785	17.685	22.23
165	5825	17.662	22.07

Channel 149 (5745MHz)



Channel 157(5785MHz)



Channel 165 (5825MHz)



Note: For this test item, the modulation of this mode we have evaluated two antennas, presented data in the report is the worst case.

Product	:	INTEGRATED GIMBAL CAMERA
Test Item	:	Occupied Bandwidth
Test Site	:	TR-8
Test Mode	:	Mode 3: Transmit by 802.11n(40MHz)

Channel No.	Frequency (MHz)	99% Occupied Bandwidth (MHz)	26dB Occupied Bandwidth (MHz)
151	5755	36.372	45.09
159	5795	36.534	47.58

Channel 151 (5755MHz)



Channel 159(5795MHz)



Note: For this test item, the modulation of this mode we have evaluated two antennas, presented data in the report is the worst case.

6. 6dB Occupied Bandwidth

6.1. Test Equipment

Occupied Bandwidth / TR-8

Instrument	Manufacturer	Type No.	Serial No.	Cal. Due Date
Spectrum Analyzer	Agilent	N9010A	MY48030494	2016.03.10
Temperature/Humidity Meter	zhicheng	ZC1-2	TR8-TH	2016.04.09

Note: All equipments are calibrated with traceable calibrations. Each calibration is traceable to the national or international standards.

6.2. Test Setup

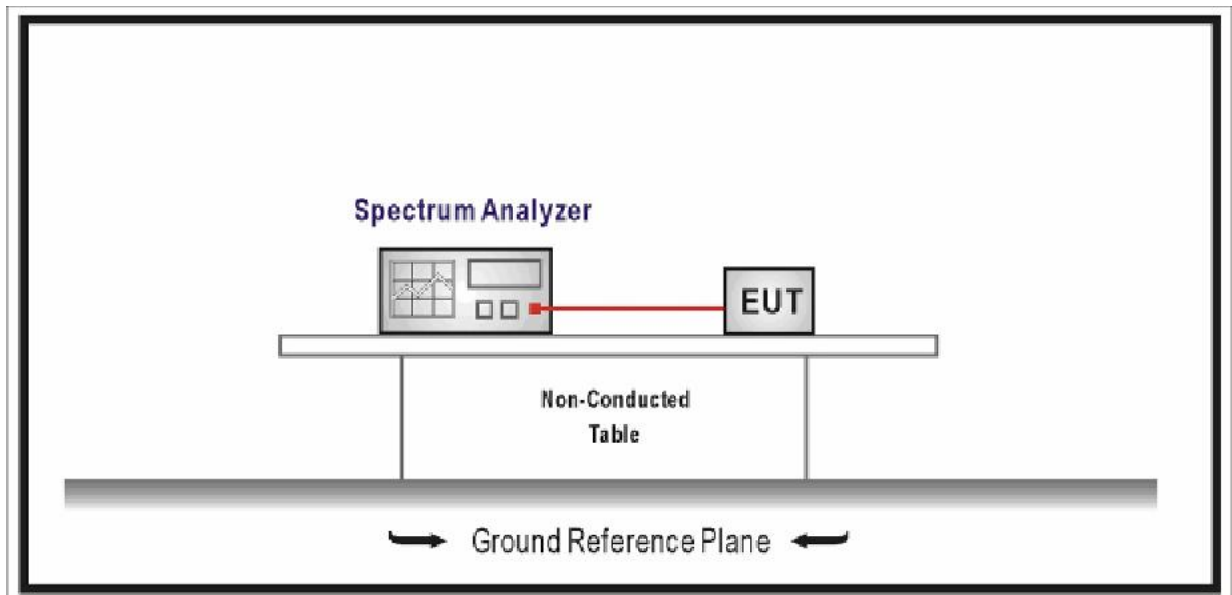

6.3. Limit

For FCC&IC

The minimum 6 dB bandwidth shall be 500 kHz.

6.4. Test Procedure

According to ANSI C63.4:2014& ANSI C63.10:2013&789033 D02 General UNII Test Procedures New Rules v01& FCC CFR Title 47 Part 15 Subpart E: 2014& Industry Canada RSS-Gen Issue 4 Industry Canada RSS-247 Issue 1

- a) Set RBW = in the range of 1% to 5% of the OBW.
- b) Set the video bandwidth (VBW) $\geq 3 \times$ RBW.
- c) Detector = Peak.
- d) Trace mode = max hold.
- e) Sweep = auto couple.
- f) Allow the trace to stabilize.
- g) Use the -6dBm function of the instrument (if available) and report the measured bandwidth.

6.5. Uncertainty

The measurement uncertainty is defined as ± 1 kHz

6.6. Test Result

Product	:	INTEGRATED GIMBAL CAMERA
Test Item	:	Occupied Bandwidth
Test Site	:	TR-8
Test Mode	:	Mode 1: Transmit by 802.11a

Channel No.	Frequency (MHz)	6dB Occupied Bandwidth (MHz)
149	5745	16.33
157	5785	16.44
165	5825	16.45

Channel 149 (5745MHz)



Channel 157(5785MHz)



Channel 165 (5825MHz)



Note: For this test item, the modulation of this mode we have evaluated two antennas, presented data in the report is the worst case.

Product	:	INTEGRATED GIMBAL CAMERA
Test Item	:	Occupied Bandwidth
Test Site	:	TR-8
Test Mode	:	Mode 2: Transmit by 802.11n(20MHz)

Channel No.	Frequency (MHz)	6dB Occupied Bandwidth (MHz)
149	5745	17.52
157	5785	17.26
165	5825	17.27

Channel 149 (5745MHz)



Channel 157(5785MHz)



Channel 165 (5825MHz)



Note: For this test item, the modulation of this mode we have evaluated two antennas, presented data in the report is the worst case.

Product	:	INTEGRATED GIMBAL CAMERA
Test Item	:	Occupied Bandwidth
Test Site	:	TR-8
Test Mode	:	Mode 3: Transmit by 802.11n(40MHz)

Channel No.	Frequency (MHz)	6dB Occupied Bandwidth (MHz)
151	5755	36.30
159	5795	36.32

Channel 151 (5755MHz)



Channel 159(5795MHz)



Note: For this test item, the modulation of this mode we have evaluated two antennas, presented data in the report is the worst case.

7. Power Output

7.1. Test Equipment

Power Output / TR-8

Instrument	Manufacturer	Type No.	Serial No.	Cal. Due Date
Spectrum Analyzer	Agilent	N9010A	MY48030494	2016.03.10
Temperature/Humidity Meter	zhicheng	ZC1-2	TR8-TH	2016.04.09

Note: All equipments are calibrated with traceable calibrations. Each calibration is traceable to the national or international standards.

7.2. Test Setup

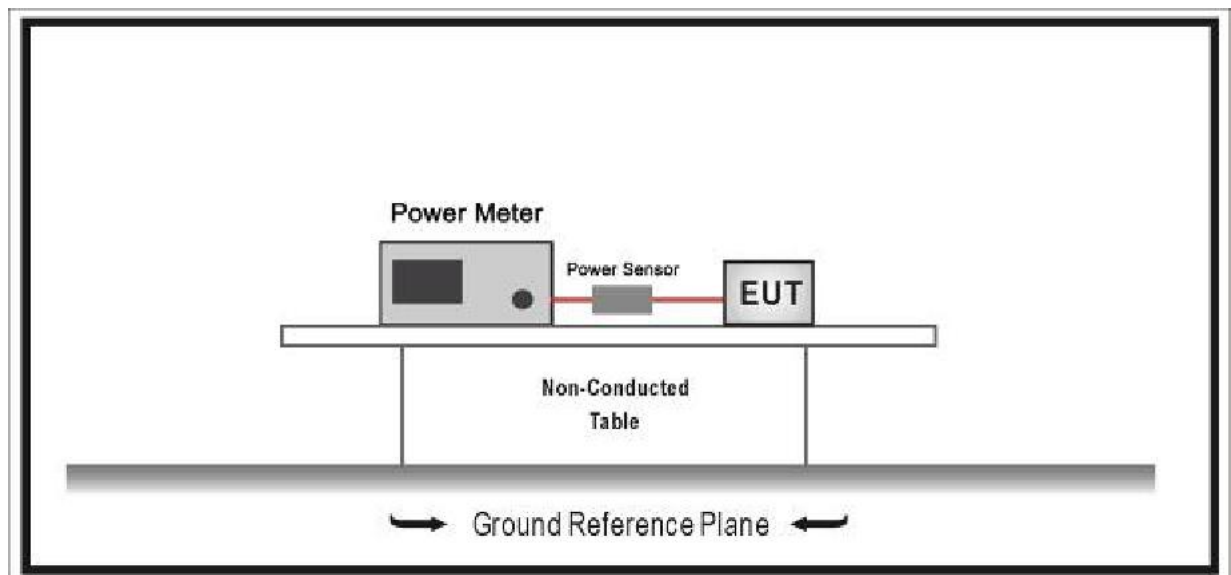

7.3. Limit

For FCC

- For an outdoor access point operating in the band 5.15-5.25 GHz, the maximum conducted output power over the frequency band of operation shall not exceed 1 W provided the maximum antenna gain does not exceed 6 dBi. In addition, the maximum power spectral density shall not exceed 17 dBm in any 1 megahertz band. If transmitting antennas of directional gain greater than 6 dBi are used, both the maximum conducted output power and the maximum power spectral density shall be reduced by the amount in dB that the directional gain of the antenna exceeds 6 dBi. The maximum e.i.r.p. at any elevation angle above 30 degrees as measured from the horizon must not exceed 125 mW (21 dBm).

- For the 5.25-5.35 GHz and 5.47-5.725 GHz bands, the maximum conducted output power over the frequency bands of operation shall not exceed the lesser of 250 mW or $11 \text{ dBm} + 10 \log B$, where B is the 26 dB emission bandwidth in megahertz. In addition, the maximum power spectral density shall not exceed 11 dBm in any 1 megahertz band. If transmitting antennas of directional gain greater than 6 dBi are used, both the maximum conducted output power and the maximum power spectral density shall be reduced by the amount in dB that the directional gain of the antenna exceeds 6 dBi.
- For the band 5.725-5.85 GHz, the maximum conducted output power over the frequency band of operation shall not exceed 1 W. In addition, the maximum power spectral density shall not exceed 30 dBm in any 500-kHz band. If transmitting antennas of directional gain greater than 6 dBi are used, both the maximum conducted output power and the maximum power spectral density shall be reduced by the amount in dB that the directional gain of the antenna exceeds 6 dBi. However, fixed point-to-point U-NII devices operating in this band may employ transmitting antennas with directional gain greater than 6 dBi without any corresponding reduction in transmitter conducted power. Fixed, point-to-point operations exclude the use of point-to-multipoint systems, omnidirectional applications, and multiple collocated transmitters transmitting the same information. The operator of the U-NII device, or if the equipment is professionally installed, the installer, is responsible for ensuring that systems employing high gain directional antennas are used exclusively for fixed, point-to-point operations.

For IC

- For the Frequency Band 5150-5250MHz, the maximum e.i.r.p. shall not exceed 200 mW or $10 + 10 \log 10B$, dBm, whichever power is less. B is the 99% emission bandwidth in megahertz. The e.i.r.p. spectral density shall not exceed 10 dBm in any 1.0 MHz band..
- For the Frequency Band 5250-5350MHz, the maximum conducted output power shall not exceed 250 mW or $11 + 10 \log 10B$, dBm, whichever is less. The power spectral density shall not exceed 11 dBm in any 1.0 MHz band.
The maximum e.i.r.p. shall not exceed 1.0 W or $17 + 10 \log 10B$, dBm, whichever is less. B is the 99% emission bandwidth in megahertz. Note that devices with a maximum e.i.r.p. greater than 500 mW shall implement TPC in order to have the capability to operate at least 6 dB below the maximum permitted e.i.r.p. of 1 W.
- For the Frequency Band 5470-5600, 5650-5725MHz, The maximum conducted output power shall not exceed 250 mW or $11 + 10 \log 10B$, dBm, whichever is less. The power spectral density shall not exceed 11 dBm in any 1.0 MHz band.
The maximum e.i.r.p. shall not exceed 1.0 W or $17 + 10 \log 10B$, dBm, whichever is less. B is the 99% emission bandwidth in megahertz. Note that devices with a maximum e.i.r.p.

greater than 500 mW shall implement TPC in order to have the capability to operate at least 6 dB below the maximum permitted e.i.r.p. of 1 W.

- For the Frequency Band 5725-5850MHz, The maximum conducted output power shall not exceed 1 W. The power spectral density shall not exceed 30 dBm in any 500 kHz band. If transmitting antennas of directional gain greater than 6 dBi are used, both the maximum conducted output power and the power spectral density shall be reduced by the amount in dB that the directional gain of the antenna exceeds 6 dBi. However, fixed point-to-point devices operating in this band may employ transmitting antennas with directional gain greater than 6 dBi without any corresponding reduction in transmitter conducted power. Fixed point-to-point operations exclude the use of point-to-multipointFootnote3 systems, omnidirectional applications and multiple collocated transmitters transmitting the same information.

7.4. Test Procedure

According to ANSI C63.4:2014& ANSI C63.10:2013&789033 D02 General UNII Test Procedures New Rules v01& FCC CFR Title 47 Part 15 Subpart E: 2014& Industry Canada RSS-Gen Issue 4 Industry Canada RSS-247 Issue 1

Use the wideband power meter to test RMS power and record the result.

7.5. Uncertainty

The measurement uncertainty is defined as ± 1.27 dB

7.6. Test Result

Power output test was verified over all data rates of each mode with Ant 1 shown as below, and then choose the maximum power output (blue marker) for final test of each channel.

Power output at various data rates:

Test Mode	Bandwidth	Frequency (MHz)	Channel	Data Rate	Average Power (dBm)
802.11a	20	5745	149	6	18.05
				24	17.96
				54	17.83
802.11n(20MHz)	20	5745	149	MCS0	17.34
				MCS4	17.26
				MCS7	17.22
802.11n(40MHz)	40	5755	151	MCS0	16.65
				MCS4	16.58
				MCS7	16.54

Product	:	INTEGRATED GIMBAL CAMERA
Test Item	:	Power Output
Test Site	:	TR-8
Test Mode	:	Mode 1: Transmit by 802.11a

Channel No.	Frequency (MHz)	Measurement Power Output (dBm)		Limit (dBm)
		Ant 1	Ant 2	
149	5745	18.05	17.63	30
157	5785	16.55	17.78	30
165	5825	16.57	17.75	30

Product	:	INTEGRATED GIMBAL CAMERA
Test Item	:	Power Output
Test Site	:	TR-8
Test Mode	:	Mode 2: Transmit by 802.11n(20MHz)

Channel No.	Frequency (MHz)	Measurement Power Output (dBm)		Limit (dBm)
		Ant 1	Ant 2	
149	5745	17.34	17.05	30
157	5785	16.17	17.17	30
165	5825	16.59	17.85	30

Product	:	INTEGRATED GIMBAL CAMERA
Test Item	:	Power Output
Test Site	:	TR-8
Test Mode	:	Mode 3: Transmit by 802.11n(40MHz)

Channel No.	Frequency (MHz)	Measurement Power Output (dBm)		Limit (dBm)
		Ant 1	Ant 2	
151	5755	16.65	16.52	30
159	5795	15.38	17.13	30

8. Peak Power Spectral Density

8.1. Test Equipment

Peak Power Spectral Density / TR-8

Instrument	Manufacturer	Type No.	Serial No.	Cal. Due Date
Spectrum Analyzer	Agilent	N9010A	MY48030494	2016.03.10
Temperature/Humidity Meter	zhicheng	ZC1-2	TR8-TH	2016.04.09

Note: All equipments are calibrated with traceable calibrations. Each calibration is traceable to the national or international standards.

8.2. Test Setup

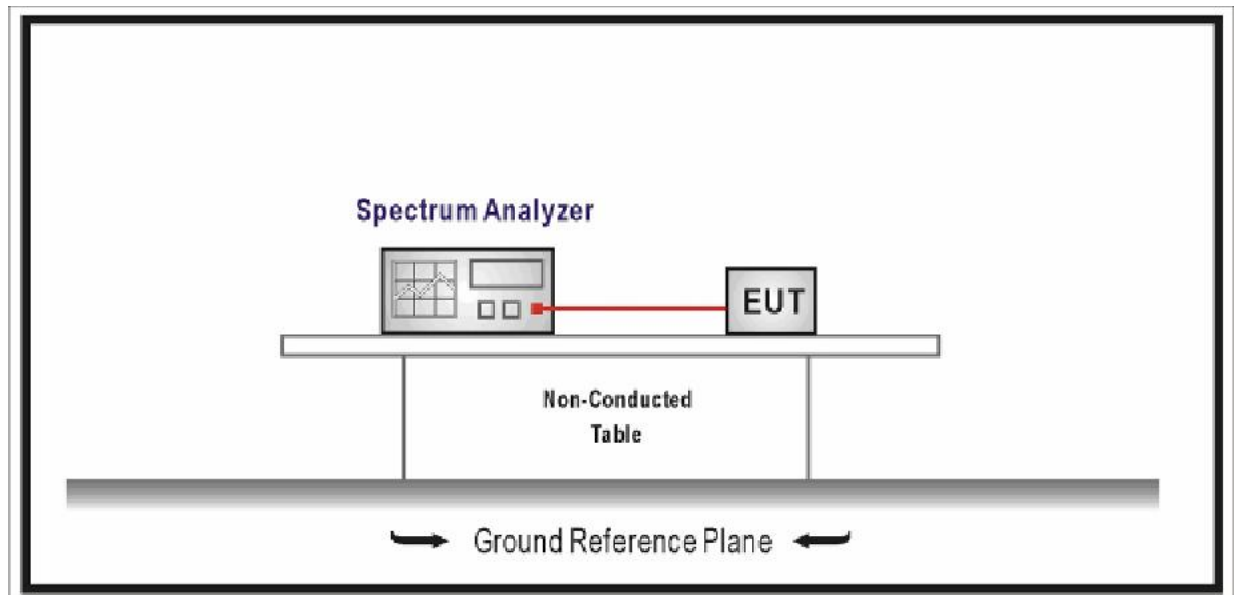

8.3. Limit

For FCC

- For an outdoor access point operating in the band 5.15-5.25 GHz, the maximum conducted output power over the frequency band of operation shall not exceed 1 W provided the maximum antenna gain does not exceed 6 dBi. In addition, the maximum power spectral density shall not exceed 17 dBm in any 1 megahertz band. If transmitting antennas of directional gain greater than 6 dBi are used, both the maximum conducted output power and the maximum power spectral density shall be reduced by the amount in dB that the directional gain of the antenna exceeds 6 dBi. The maximum e.i.r.p. at any elevation angle above 30 degrees as measured from the horizon must not exceed 125 mW

(21 dBm).

- For the 5.25-5.35 GHz and 5.47-5.725 GHz bands, the maximum conducted output power over the frequency bands of operation shall not exceed the lesser of 250 mW or $11 \text{ dBm} + 10 \log B$, where B is the 26 dB emission bandwidth in megahertz. In addition, the maximum power spectral density shall not exceed 11 dBm in any 1 megahertz band. If transmitting antennas of directional gain greater than 6 dBi are used, both the maximum conducted output power and the maximum power spectral density shall be reduced by the amount in dB that the directional gain of the antenna exceeds 6 dBi.
- For the band 5.725-5.85 GHz, the maximum conducted output power over the frequency band of operation shall not exceed 1 W. In addition, the maximum power spectral density shall not exceed 30 dBm in any 500-kHz band. If transmitting antennas of directional gain greater than 6 dBi are used, both the maximum conducted output power and the maximum power spectral density shall be reduced by the amount in dB that the directional gain of the antenna exceeds 6 dBi. However, fixed point-to-point U-NII devices operating in this band may employ transmitting antennas with directional gain greater than 6 dBi without any corresponding reduction in transmitter conducted power. Fixed, point-to-point operations exclude the use of point-to-multipoint systems, omnidirectional applications, and multiple collocated transmitters transmitting the same information. The operator of the U-NII device, or if the equipment is professionally installed, the installer, is responsible for ensuring that systems employing high gain directional antennas are used exclusively for fixed, point-to-point operations.

For IC

- For the Frequency Band 5150-5250MHz, the maximum e.i.r.p. shall not exceed 200 mW or $10 + 10 \log 10B$, dBm, whichever power is less. B is the 99% emission bandwidth in megahertz. The e.i.r.p. spectral density shall not exceed 10 dBm in any 1.0 MHz band..
- For the Frequency Band 5250-5350MHz, the maximum conducted output power shall not exceed 250 mW or $11 + 10 \log 10B$, dBm, whichever is less. The power spectral density shall not exceed 11 dBm in any 1.0 MHz band.
The maximum e.i.r.p. shall not exceed 1.0 W or $17 + 10 \log 10B$, dBm, whichever is less. B is the 99% emission bandwidth in megahertz. Note that devices with a maximum e.i.r.p. greater than 500 mW shall implement TPC in order to have the capability to operate at least 6 dB below the maximum permitted e.i.r.p. of 1 W.
- For the Frequency Band 5470-5600, 5650-5725MHz, The maximum conducted output power shall not exceed 250 mW or $11 + 10 \log 10B$, dBm, whichever is less. The power spectral density shall not exceed 11 dBm in any 1.0 MHz band.
The maximum e.i.r.p. shall not exceed 1.0 W or $17 + 10 \log 10B$, dBm, whichever is less. B

is the 99% emission bandwidth in megahertz. Note that devices with a maximum e.i.r.p. greater than 500 mW shall implement TPC in order to have the capability to operate at least 6 dB below the maximum permitted e.i.r.p. of 1 W.

- For the Frequency Band 5725-5850MHz, The maximum conducted output power shall not exceed 1 W. The power spectral density shall not exceed 30 dBm in any 500 kHz band. If transmitting antennas of directional gain greater than 6 dBi are used, both the maximum conducted output power and the power spectral density shall be reduced by the amount in dB that the directional gain of the antenna exceeds 6 dBi. However, fixed point-to-point devices operating in this band may employ transmitting antennas with directional gain greater than 6 dBi without any corresponding reduction in transmitter conducted power. Fixed point-to-point operations exclude the use of point-to-multipoint^{Footnote3} systems, omnidirectional applications and multiple collocated transmitters transmitting the same information.

8.4. Test Procedure

According to ANSI C63.4:2014& ANSI C63.10:2013&789033 D02 General UNII Test Procedures New Rules v01& FCC CFR Title 47 Part 15 Subpart E: 2014& Industry Canada RSS-Gen Issue 4 Industry Canada RSS-247 Issue 1.

Set span to encompass the entire emission bandwidth (EBW) of the signal.

For 5150-5725MHz

- a) Set RBW = 1 MHz.
- b) Set VBW \geq 3 MHz.
- c) Sweep time = auto.
- d) Detector = RMS (i.e., power averaging), if available. Otherwise, use sample detector mode.

For 5725-5875MHz

- e) Set RBW=510KHz
- f) VBW \geq 3RBW
- g) Sweep time=auto
- h) Detector = RMS (i.e., power averaging), if available. Otherwise, use sample detector mode.
- i) Scale the observed power level to an equivalent value in 500 kHz by adjusting (increase) the measured power by a bandwidth correction factor (BWCF) where BWCF = $10 \log(500 \text{ kHz}/100 \text{ kHz}) = 6.98 \text{ dB}$.

8.5. Uncertainty

The measurement uncertainty is defined as $\pm 1.27 \text{ dB}$

8.6. Test Result

Product	:	INTEGRATED GIMBAL CAMERA
Test Item	:	Peak Power Spectral Density
Test Site	:	TR-8
Test Mode	:	Mode 1: Transmit by 802.11a

Channel No.	Frequency (MHz)	Reading PPSD (dBm/MHz)		Duty Cycle (%)	Mearsured PPSD (dBm/MHz)		Limit (dBm/MHz)
		Ant 1	Ant 2		Ant 1	Ant 2	
149	5745	2.177	3.881	99.9	2.177	3.881	30
157	5785	3.014	3.180	99.9	3.014	3.180	30
165	5825	2.256	2.595	99.9	2.256	2.595	30

Ant 1

Channel 149 (5745MHz)



Channel 157(5785MHz)



Channel 165 (5825MHz)



Ant 2 Channel 149 (5745MHz)



Channel 157(5785MHz)



Channel 165 (5825MHz)



Product	:	INTEGRATED GIMBAL CAMERA
Test Item	:	Peak Power Spectral Density
Test Site	:	TR-8
Test Mode	:	Mode 2: Transmit by 802.11n(20MHz)

Channel No.	Frequency (MHz)	Reading PPSD (dBm/MHz)		Duty Cycle (%)	Mearsured PPSD (dBm/MHz)		Limit (dBm/MHz)
		Ant 1	Ant 2		Ant 1	Ant 2	
149	5745	3.985	4.182	99.9	3.985	4.182	30
157	5785	3.692	4.309	99.9	3.692	4.309	30
165	5825	2.732	3.923	99.9	2.732	3.923	30

Ant 1
Channel 149 (5745MHz)



Channel 157(5785MHz)



Channel 165 (5825MHz)



Ant 2
Channel 149 (5745MHz)



Channel 157(5785MHz)



Channel 165 (5825MHz)



Product	:	INTEGRATED GIMBAL CAMERA
Test Item	:	Peak Power Spectral Density
Test Site	:	TR-8
Test Mode	:	Mode 3: Transmit by 802.11n(40MHz)

Channel No.	Frequency (MHz)	Reading PPSD (dBm/MHz)		Duty Cycle (%)	Mearsured PPSD (dBm/MHz)		Limit (dBm/MHz)
		Ant 1	Ant 2		Ant 1	Ant 2	
151	5745	-0.015	0.549	99.9	-0.015	0.549	30
159	5785	-0.384	0.094	99.9	-0.384	0.094	30

Ant 1
Channel 151 (5755MHz)



Channel 159(5795MHz)



Ant 2 Channel 151 (5755MHz)



Channel 159(5795MHz)



9. Radiated Emission Band Edge

9.1. Test Equipment

Radiated Emission Band Edge / AC-5

Instrument	Manufacturer	Type No.	Serial No.	Cal. Due Date
Spectrum Analyzer	Agilent	N9010A	MY48030494	2016.03.10
Preamplifier	Miteq	NSP1800-25	1364185	2016.05.03
Preamplifier	QuieTek	AP-040G	CHM-0906001	2016.05.03
Bilog Antenna	Teseq GmbH	CBL6112D	27612	2016.10.15
DRG Horn	ETS-Lindgren	3117	00123988	2017.01.04
Coaxial Cable	Huber+Suhner	SUCOFLEX 106	AC5-C1	2016.03.01
Coaxial Cable	Huber+Suhner	SUCOFLEX 106	AC5-C2	2016.03.01
Coaxial Cable	Huber+Suhner	SUCOFLEX 102	AC5-C3	2016.03.01
EMI Receiver	Agilent	N9038A	MY51210196	2016.06.09
Temperature/Humidity Meter	Zhichen	ZC1-2	AC5-TH	2017.01.04

9.2. Test Setup

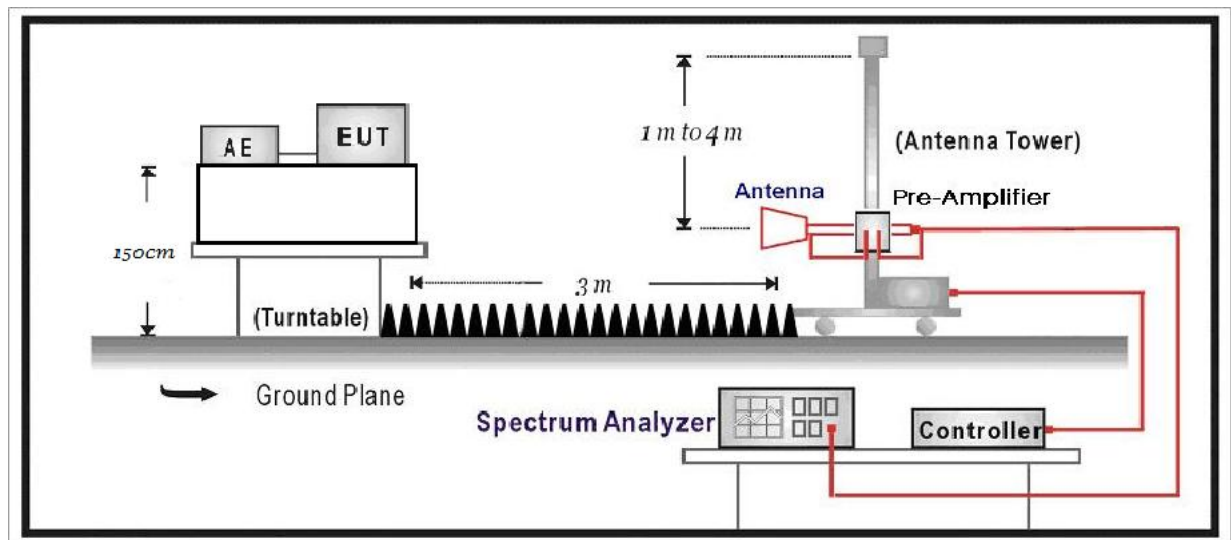

9.3. Limit

For FCC&IC

For 15.205 requirement:

Radiated emissions which fall in the restricted bands, as defined in Section 15.205(a) of FCC part 15, must also comply with the radiated emission limits specified in Section 15.209(a).

MHz	MHz	MHz	GHz
0.090 - 0.110	16.42 - 16.423	399.9 - 410	4.5 - 5.15
0.495 - 0.505	16.69475 - 16.69525	608 - 614	5.35 - 5.46
2.1735 - 2.1905	16.80425 - 16.80475	960 - 1240	7.25 - 7.75
4.125 - 4.128	25.5 - 25.67	1300 - 1427	8.025 - 8.5
4.17725 - 4.17775	37.5 - 38.25	1435 - 1626.5	9.0 - 9.2
4.20725 - 4.20775	73 - 74.6	1645.5 - 1646.5	9.3 - 9.5
6.215 - 6.218	74.8 - 75.2	1660 - 1710	10.6 - 12.7
6.26775 - 6.26825	108 - 121.94	1718.8 - 1722.2	13.25 - 13.4
6.31175 - 6.31225	123 - 138	2200 - 2300	14.47 - 14.5
8.291 - 8.294	149.9 - 150.05	2310 - 2390	15.35 - 16.2
8.362 - 8.366	156.52475 - 156.52525	2483.5 - 2500	17.7 - 21.4
8.37625 - 8.38675	156.7 - 156.9	2690 - 2900	22.01 - 23.12
8.41425 - 8.41475	162.0125 - 167.17	3260 - 3267	23.6 - 24.0
12.29 - 12.293	167.72 - 173.2	3332 - 3339	31.2 - 31.8
12.51975 - 12.52025	240 - 285	3345.8 - 3358	36.43 - 36.5
12.57675 - 12.57725	322 - 335.4	3600 - 4400	(3)

For RSS-GEN requirement:

Radiated emissions which fall in the restricted bands, as defined in Section 8.10 of RSS-GEN, must also comply with the radiated emission limits specified in Section 8.10.

MHz	MHz	GHz
0.090-0.110	74.8-75.2	9.0-9.2
2.1735-2.1905	108-138	9.3-9.5
3.020-3.026	156.52475-156.52525	10.6-12.7
4.125-4.128	156.7-156.9	13.25-13.4
4.17725-4.17775	240-285	14.47-14.5
4.20725-4.20775	322-335.4	15.35-16.2
5.677-5.683	399.9-410	17.7-21.4
6.215-6.218	608-614	22.01-23.12
6.26775-6.26825	960-1427	23.6-24.0
6.31175-6.31225	1435-1626.5	31.2-31.8
8.291-8.294	1645.5-1646.5	36.43-36.5
8.362-8.366	1660-1710	Above 38.6
8.37625-8.38675	1718.8-1722.2	
8.41425-8.41475	2200-2300	
12.29-12.293	2310-2390	
12.51975-12.52025	2655-2900	
12.57675-12.57725	3260-3267	
13.36-13.41	3332-3339	
16.42-16.423	3345.8-3358	
16.69475-16.69525	3500-4400	
16.80425-16.80475	4500-5150	
25.5-25.67	5350-5460	
37.5-38.25	7250-7750	
73-74.6	8025-8500	

For 15.407(b) requirement:

- (1) For transmitters operating in the 5.15-5.25 GHz band: All emissions outside of the 5.15-5.35 GHz band shall not exceed an e.i.r.p. of -27 dBm/MHz.
- (2) For transmitters operating in the 5.25-5.35 GHz band: All emissions outside of the 5.15-5.35 GHz band shall not exceed an e.i.r.p. of -27 dBm/MHz.
- (3) For transmitters operating in the 5.47-5.725 GHz band: All emissions outside of the 5.47-5.725 GHz band shall not exceed an e.i.r.p. of -27 dBm/MHz.
- (4) For transmitters operating in the 5.725-5.85 GHz band: All emissions within the frequency range from the band edge to 10 MHz above or below the band edge shall not exceed an e.i.r.p. of -17 dBm/MHz; for frequencies 10 MHz or greater above or below the band edge, emissions shall not exceed an e.i.r.p. of -27 dBm/MHz.

Operating Frequency Band (MHz)	EIRP Limit (dBm/MHz)	Equivalent Field Strength at 3m (dBuV/m)
5150 - 5250	-27	68.3
5250 - 5350	-27	68.3
5470 - 5725	-27	68.3
5725 - 5825	-27 [Note(1)]	68.3
	-17 [Note(2)]	78.3

Note(1): Outside the frequency range 5715 - 5835MHz.

Note(2): Within the frequency range from the band edge to 10MHz below or above the band edge, 5715 – 5725MHz and 5825 - 5835MHz.

9.4. Test Procedure

According to ANSI C63.4:2014& ANSI C63.10:2013&789033 D02 General UNII Test Procedures New Rules v01& FCC CFR Title 47 Part 15 Subpart E: 2015& Industry Canada RSS-Gen Issue 4 Industry Canada RSS-247 Issue 1.

The EUT is placed on a turn table which is 1.5 meter above ground. The turn table is rotated 360 degrees to determine the position of the maximum emission level. The EUT was positioned such that the distance from antenna to the EUT was 3 meters.

The antenna is scanned from 1 meter to 4 meters to find out the maximum emission level. This is repeated for both horizontal and vertical polarization of the antenna. In order to find the maximum emission, all of the interface cables were manipulated according to ANSI C63.4: 2009 on radiated measurement.

The procedure for peak unwanted emissions measurements above 1000 MHz is as follows:
Peak emission levels are measured by setting the instrument as follows:

- 1) RBW = 1 MHz.
- 2) VBW \geq [3 \times RBW].
- 3) Detector = peak
- 4) Sweep time = auto.
- 5) Trace mode = max hold.
- 6) Allow sweeps to continue until the trace stabilizes. Note that if the transmission is not continuous, then the time required for the trace to stabilize will increase by a factor of approximately 1 / D, where D is the duty cycle. For example, at 50% duty cycle, the measurement time will increase by a factor of two, relative to measurement time for continuous transmission.

Average emission levels are measured by setting the instrument as follows:

- a) RBW = 1 MHz.
- b) Video bandwidth:
 - 1) If the EUT is configured to transmit with $D \geq 98\%$, then set $VBW \leq RBW / 100$ (i.e., 10 kHz), but not less than 10 Hz.
 - 2) If the EUT D is $< 98\%$, then set $VBW \geq 1 / T$, where T is defined in item a1) of 12.2.
- c) Video bandwidth mode or display mode:
 - 1) The instrument shall be set with video filtering applied in the power domain. Typically, this requires setting the detector mode to RMS (power averaging) and setting the average-VBW type to power (rms).
 - 2) As an alternative, the instrument may be set to linear detector mode. Video filtering shall be applied in linear voltage domain (rather than in a log or dB domain). Some

instruments require linear display mode to accomplish this. Others have a setting for average-VBW type, which can be set to “voltage” regardless of the display mode.

d) Detector = peak.

e) Sweep time = auto.

f) Trace mode = max hold.

g) Allow max hold to run for at least 50 traces if the transmitted signal is continuous or has at least 98% duty cycle. For lower duty cycles, increase the minimum number of traces by a factor of $1/x$, where D is the duty cycle. For example, use at least 200 traces if the duty cycle is 25%. (If a specific emission is demonstrated to be continuous—i.e., 100% duty cycle—then rather than turning ON and OFF with the transmit cycle, at least 50 traces should be averaged.)

Note: When doing emission measurement above 1GHz, the horn Chainenna will be bended down a little (as horn Chainenna has the narrow beamwidth) in order to keeping the Chainenna in the “cone of radiation” of EUT. The 3dB beamwidth is 10~60 degrees for H-plane and 10~90 degrees for E-plane.

9.5. Uncertainty

The measurement uncertainty above 1GHz is defined as ± 3.9 dB

9.6. Test Result

Engineer: Frank	
Site: AC5	Time: 2015/12/05 - 13:11
Limit: FCC-15.407 new	Margin: 0
Probe: Horn_3117_00167055(1-18GHz)	Polarity: Horizontal
EUT: INTEGRATED GIMBAL CAMERA	Power: AC 120V/60Hz
Note: Mode1: Transmit at ch5745 by 802.11a ant1	

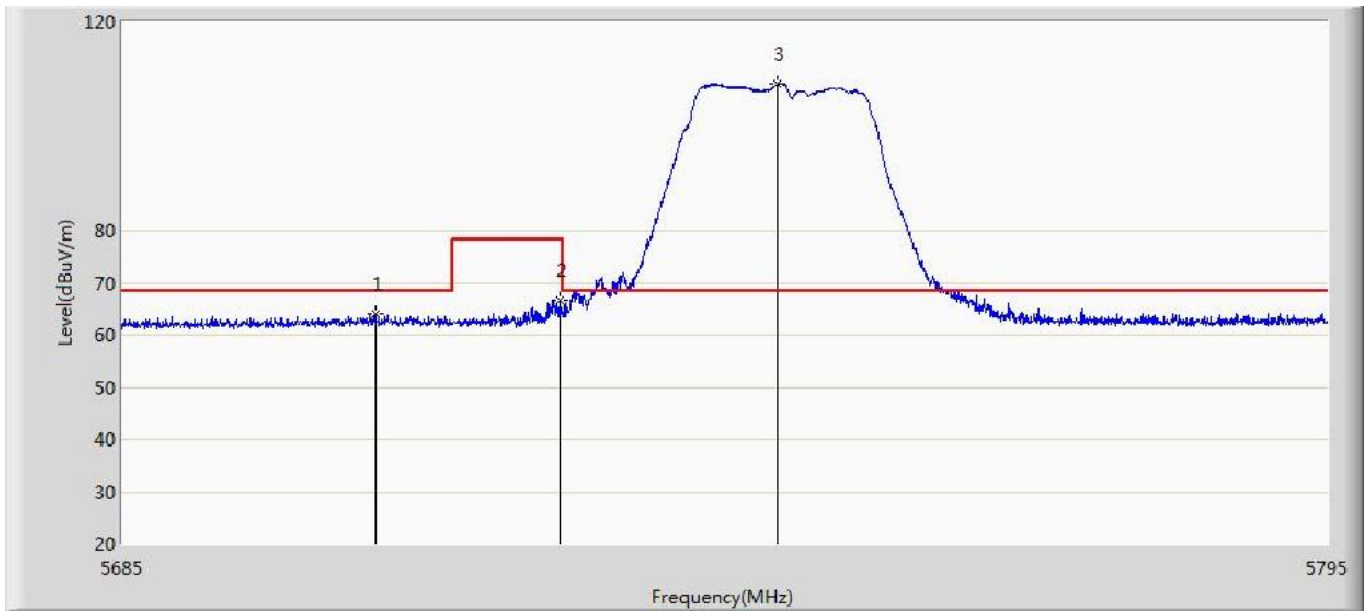

No	Mark	Frequency (MHz)	Measure Level (dBuV/m)	Reading Level (dBuV)	Over Limit (dB)	Limit (dBuV/m)	Factor (dB)	Type
1		5707.935	64.089	20.772	-4.211	68.300	43.317	PK
2		5724.710	66.570	23.303	-11.730	78.300	43.267	PK
3	*	5744.620	108.095	64.798	39.795	68.300	43.297	PK

Engineer: Frank	
Site: AC5	Time: 2015/12/05 - 13:14
Limit: FCC-15.407 new	Margin: 0
Probe: Horn_3117_00167055(1-18GHz)	Polarity: Vertical
EUT: INTEGRATED GIMBAL CAMERA	Power: AC 120V/60Hz
Note: Mode1: Transmit at ch5745 by 802.11a ant1	

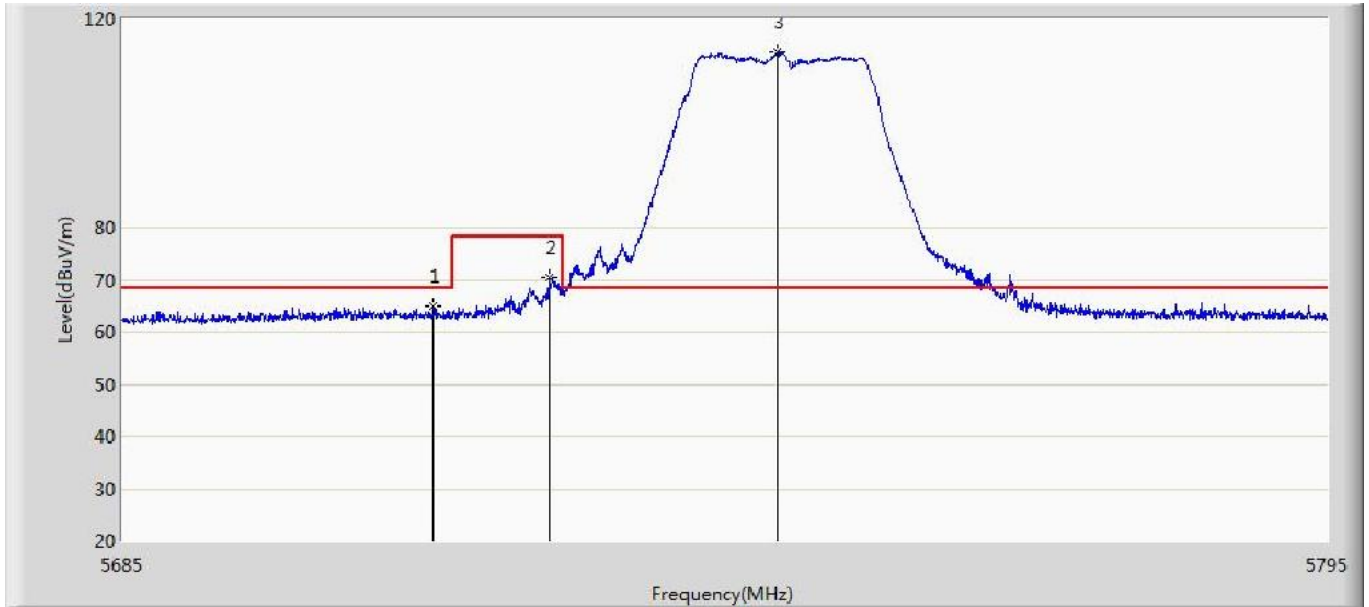

No	Mark	Frequency (MHz)	Measure Level (dBuV/m)	Reading Level (dBuV)	Over Limit (dB)	Limit (dBuV/m)	Factor (dB)	Type
1		5713.215	64.984	21.678	-3.316	68.300	43.306	PK
2		5723.775	70.534	27.264	-7.766	78.300	43.270	PK
3	*	5744.620	113.674	70.377	45.374	68.300	43.297	PK

Engineer: Frank	
Site: AC5	Time: 2015/12/05 - 13:18
Limit: FCC-15.407 new	Margin: 0
Probe: Horn_3117_00167055(1-18GHz)	Polarity: Horizontal
EUT: INTEGRATED GIMBAL CAMERA	Power: AC 120V/60Hz
Note: Mode1: Transmit at ch5825 by 802.11a ant1	

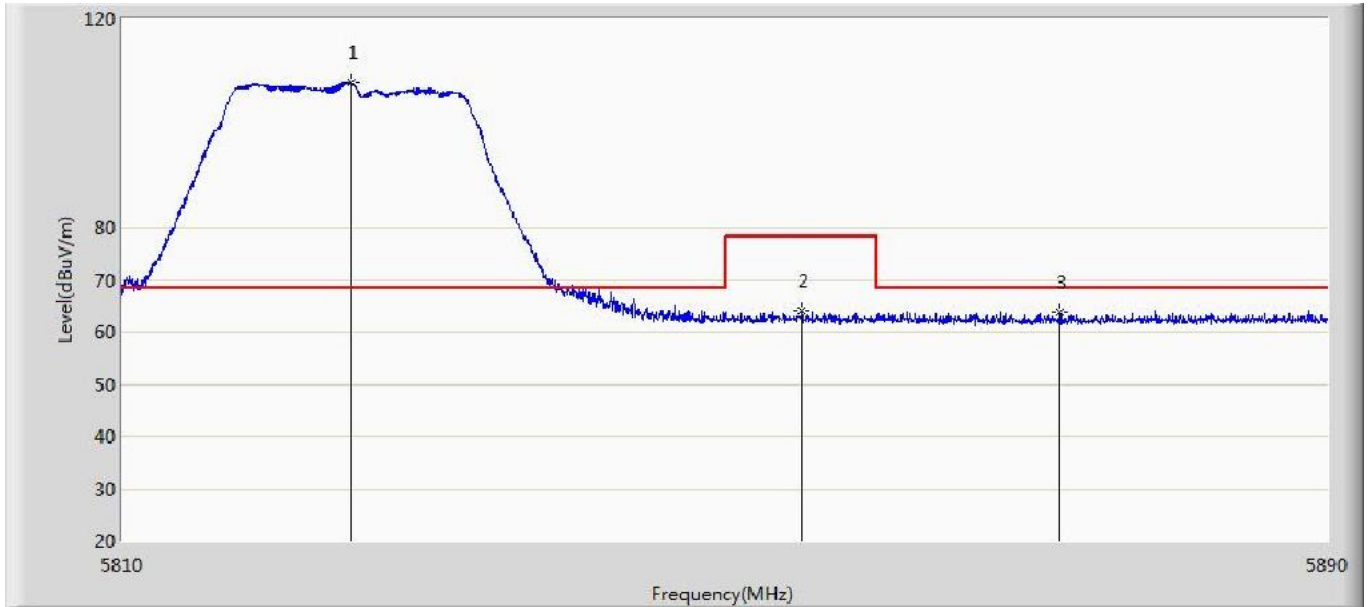

No	Mark	Frequency (MHz)	Measure Level (dBuV/m)	Reading Level (dBuV)	Over Limit (dB)	Limit (dBuV/m)	Factor (dB)	Type
1	*	5825.120	107.740	64.337	39.440	68.300	43.403	PK
2		5855.000	64.076	20.568	-14.224	78.300	43.507	PK
3		5872.200	63.737	20.144	-4.563	68.300	43.593	PK

Engineer: Frank	
Site: AC5	Time: 2015/12/05 - 13:22
Limit: FCC-15.407 new	Margin: 0
Probe: Horn_3117_00167055(1-18GHz)	Polarity: Vertical
EUT: INTEGRATED GIMBAL CAMERA	Power: AC 120V/60Hz
Note: Mode1: Transmit at ch5825 by 802.11a ant1	

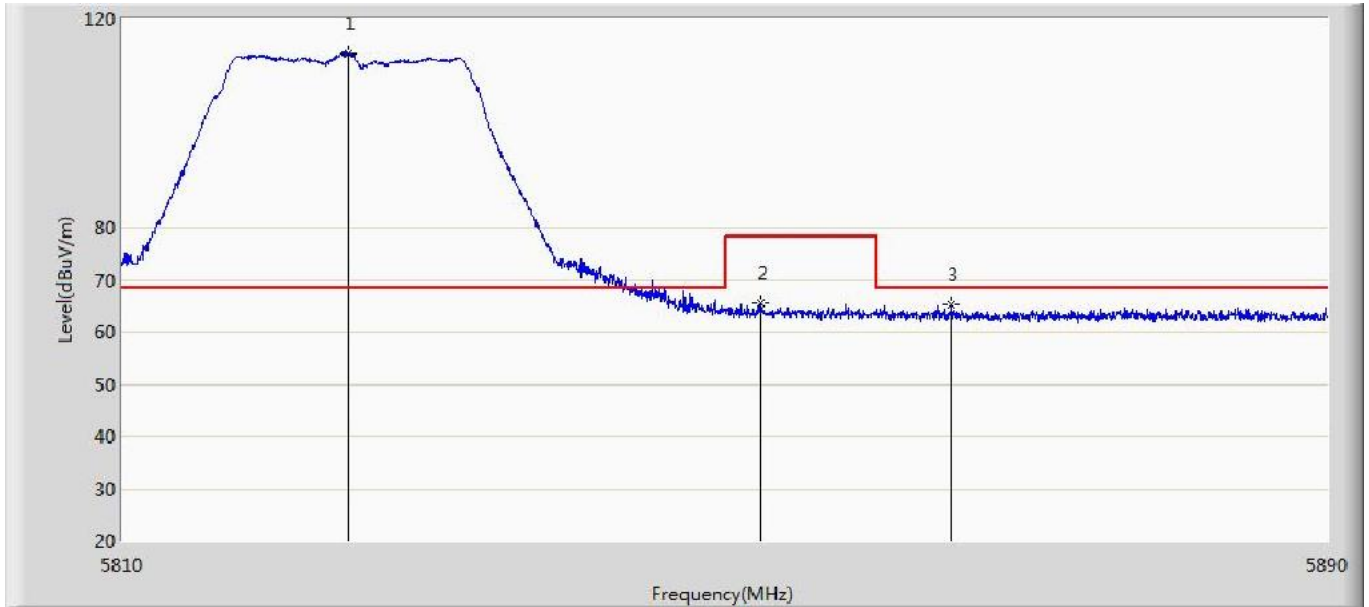

No	Mark	Frequency (MHz)	Measure Level (dBuV/m)	Reading Level (dBuV)	Over Limit (dB)	Limit (dBuV/m)	Factor (dB)	Type
1	*	5824.920	113.393	69.990	45.093	68.300	43.403	PK
2		5852.280	65.510	22.023	-12.790	78.300	43.486	PK
3		5864.960	65.170	21.600	-3.130	68.300	43.570	PK

Engineer: Frank	
Site: AC5	Time: 2015/12/05 - 13:26
Limit: FCC-15.407 new	Margin: 0
Probe: Horn_3117_00167055(1-18GHz)	Polarity: Horizontal
EUT: INTEGRATED GIMBAL CAMERA	Power: AC 120V/60Hz
Note: Mode1: Transmit at ch5745 by 802.11a ant2	

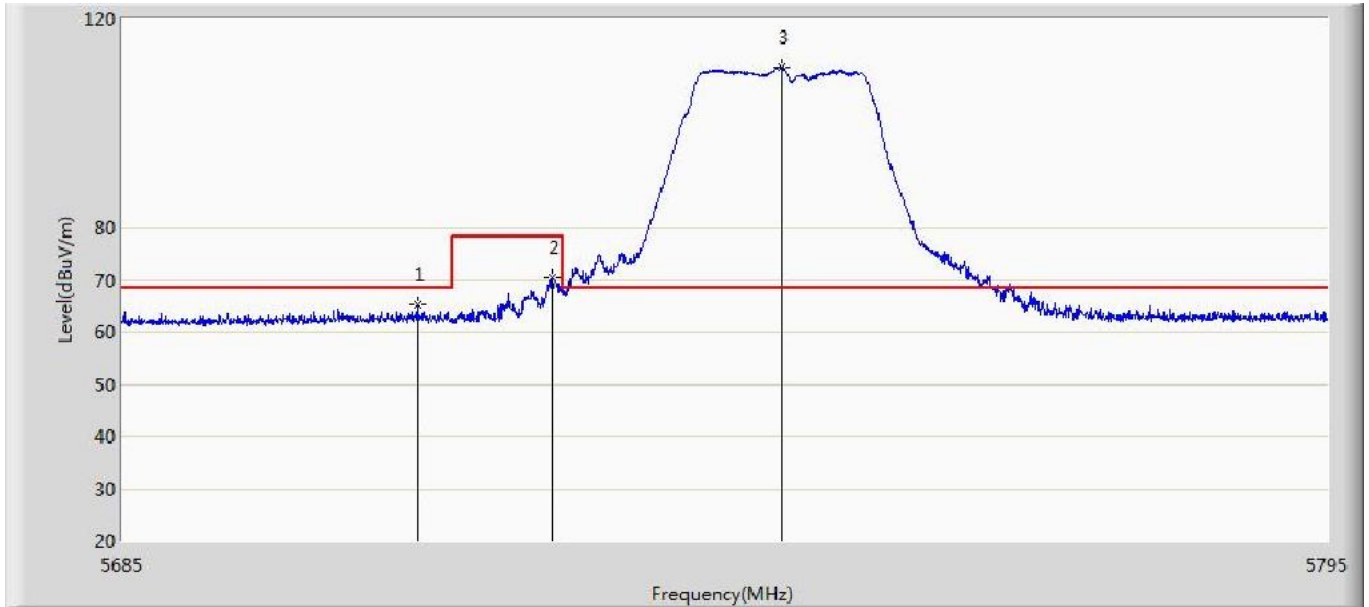

No	Mark	Frequency (MHz)	Measure Level (dBuV/m)	Reading Level (dBuV)	Over Limit (dB)	Limit (dBuV/m)	Factor (dB)	Type
1		5711.785	65.107	21.796	-3.193	68.300	43.311	PK
2		5724.105	70.468	27.199	-7.832	78.300	43.269	PK
3	*	5744.950	110.621	67.325	42.321	68.300	43.296	PK

Engineer: Frank	
Site: AC5	Time: 2015/12/05 - 13:27
Limit: FCC-15.407 new	Margin: 0
Probe: Horn_3117_00167055(1-18GHz)	Polarity: Vertical
EUT: INTEGRATED GIMBAL CAMERA	Power: AC 120V/60Hz
Note: Mode1: Transmit at ch5745 by 802.11a ant2	

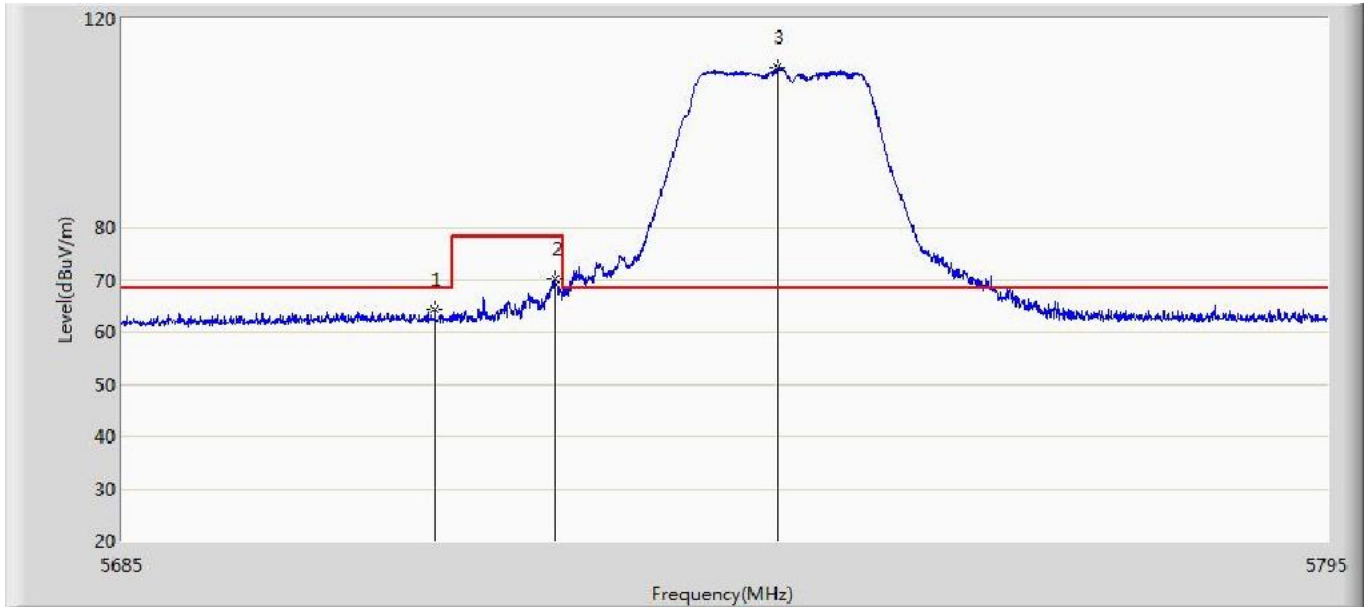

No	Mark	Frequency (MHz)	Measure Level (dBuV/m)	Reading Level (dBuV)	Over Limit (dB)	Limit (dBuV/m)	Factor (dB)	Type
1		5713.325	64.221	20.915	-4.079	68.300	43.306	PK
2		5724.270	70.046	26.778	-8.254	78.300	43.269	PK
3	*	5744.620	110.635	67.338	42.335	68.300	43.297	PK

Engineer: Frank	
Site: AC5	Time: 2015/12/05 - 13:30
Limit: FCC-15.407 new	Margin: 0
Probe: Horn_3117_00167055(1-18GHz)	Polarity: Horizontal
EUT: INTEGRATED GIMBAL CAMERA	Power: AC 120V/60Hz
Note: Mode1: Transmit at ch5825 by 802.11a ant2	

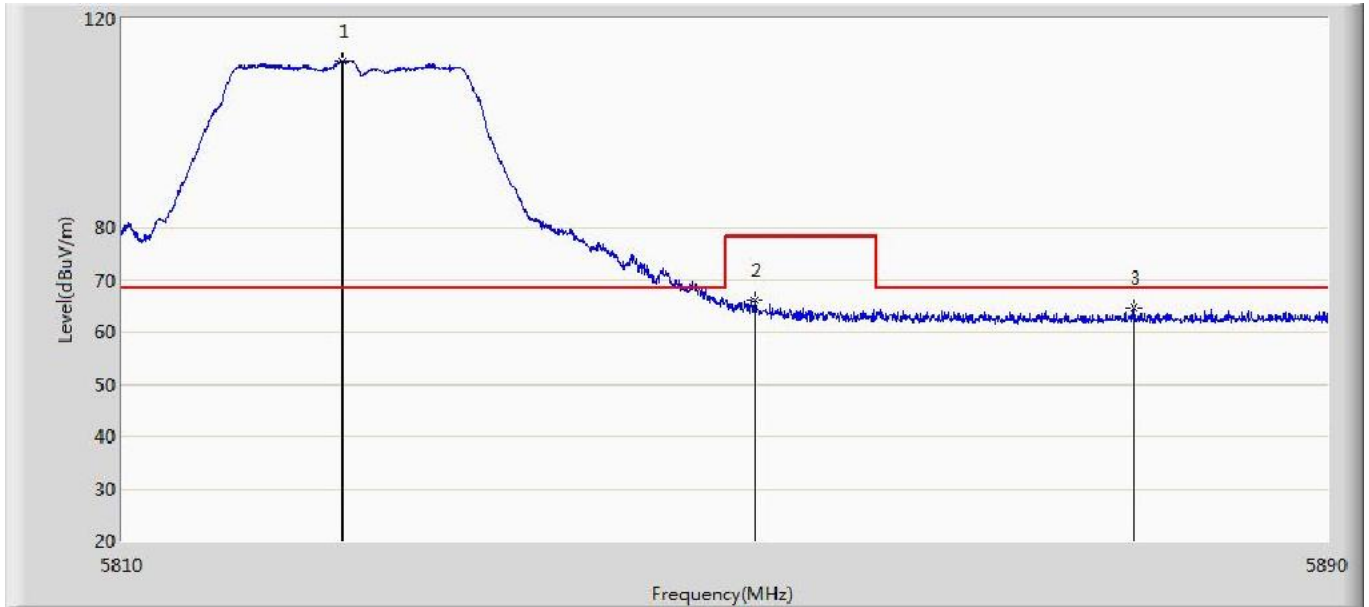

No	Mark	Frequency (MHz)	Measure Level (dBuV/m)	Reading Level (dBuV)	Over Limit (dB)	Limit (dBuV/m)	Factor (dB)	Type
1	*	5824.520	111.823	68.421	43.523	68.300	43.402	PK
2		5851.880	66.160	22.676	-12.140	78.300	43.484	PK
3		5877.080	64.698	21.090	-3.602	68.300	43.608	PK

Engineer: Frank	
Site: AC5	Time: 2015/12/05 - 13:32
Limit: FCC-15.407 new	Margin: 0
Probe: Horn_3117_00167055(1-18GHz)	Polarity: Vertical
EUT: INTEGRATED GIMBAL CAMERA	Power: AC 120V/60Hz
Note: Mode1: Transmit at ch5825 by 802.11a ant2	

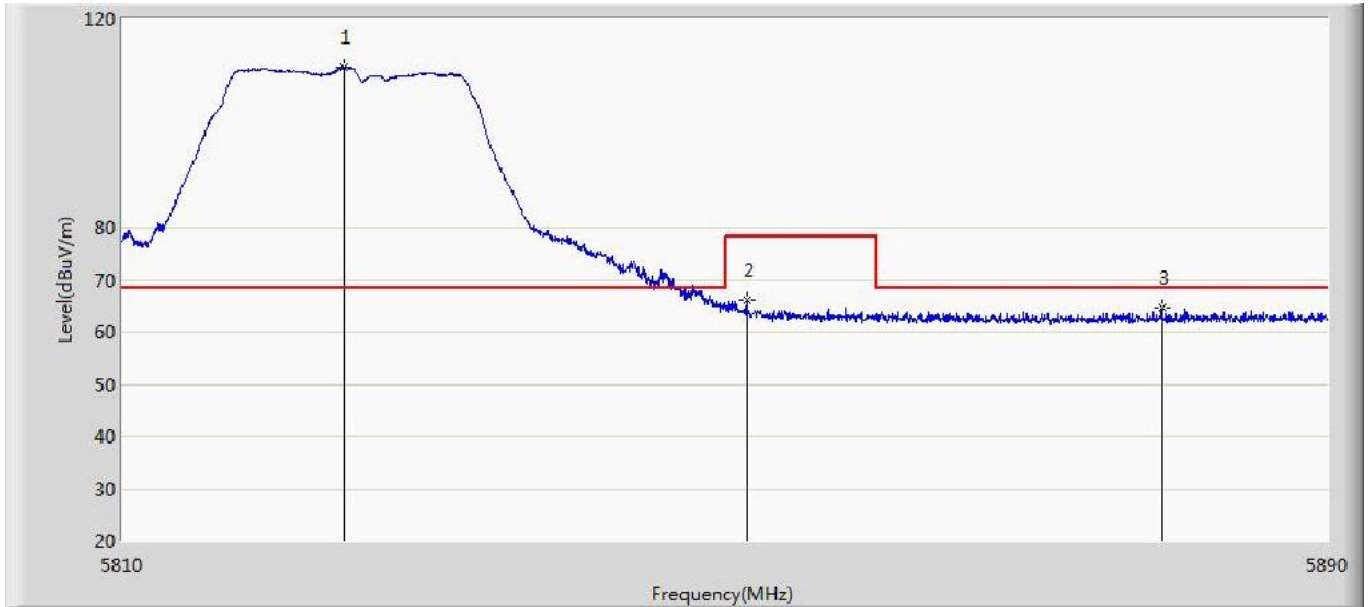

No	Mark	Frequency (MHz)	Measure Level (dBuV/m)	Reading Level (dBuV)	Over Limit (dB)	Limit (dBuV/m)	Factor (dB)	Type
1	*	5824.640	110.809	67.407	42.509	68.300	43.402	PK
2		5851.320	65.966	22.487	-12.334	78.300	43.479	PK
3		5878.960	64.679	21.065	-3.621	68.300	43.614	PK

Engineer: Frank	
Site: AC5	Time: 2015/12/05 - 13:34
Limit: FCC-15.407 new	Margin: 0
Probe: Horn_3117_00167055(1-18GHz)	Polarity: Horizontal
EUT: INTEGRATED GIMBAL CAMERA	Power: AC 120V/60Hz
Note: Mode2: Transmit at ch5745 by 802.11n(20MHz) ant1	

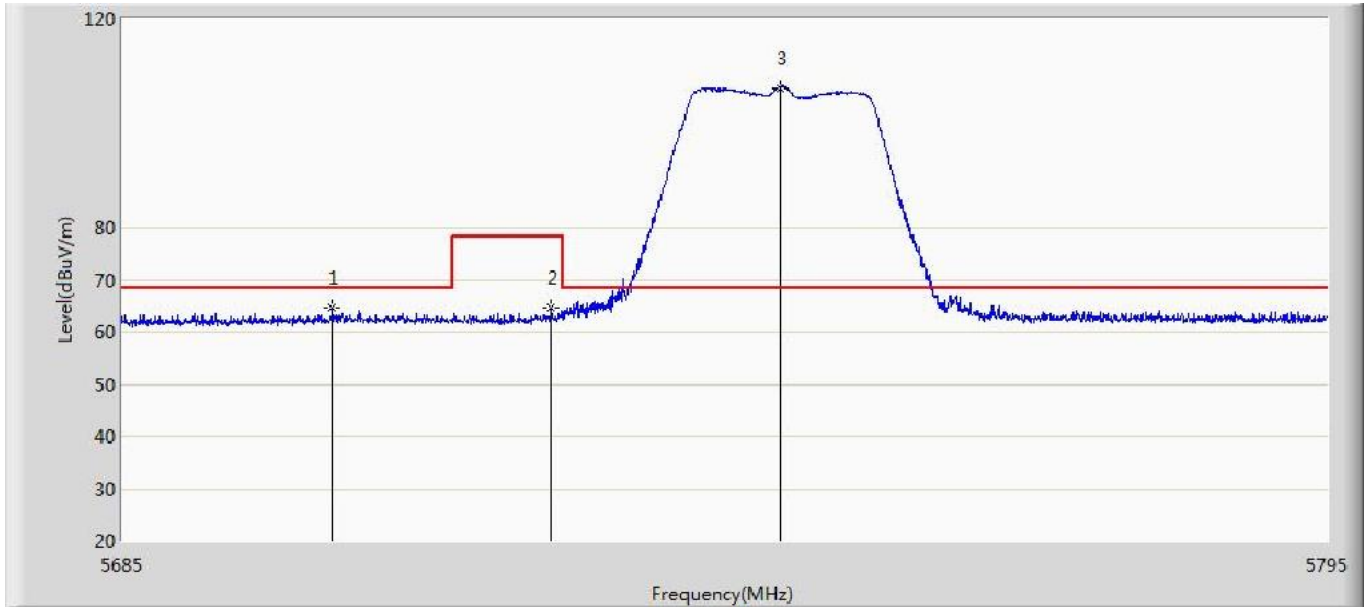

No	Mark	Frequency (MHz)	Measure Level (dBuV/m)	Reading Level (dBuV)	Over Limit (dB)	Limit (dBuV/m)	Factor (dB)	Type
1		5704.030	64.626	21.321	-3.674	68.300	43.305	PK
2		5723.940	64.737	21.467	-13.563	78.300	43.269	PK
3	*	5744.785	106.809	63.513	38.509	68.300	43.297	PK

Engineer: Frank	
Site: AC5	Time: 2015/12/05 - 13:36
Limit: FCC-15.407 new	Margin: 0
Probe: Horn_3117_00167055(1-18GHz)	Polarity: Vertical
EUT: INTEGRATED GIMBAL CAMERA	Power: AC 120V/60Hz
Note: Mode2: Transmit at ch5745 by 802.11n(20MHz) ant1	

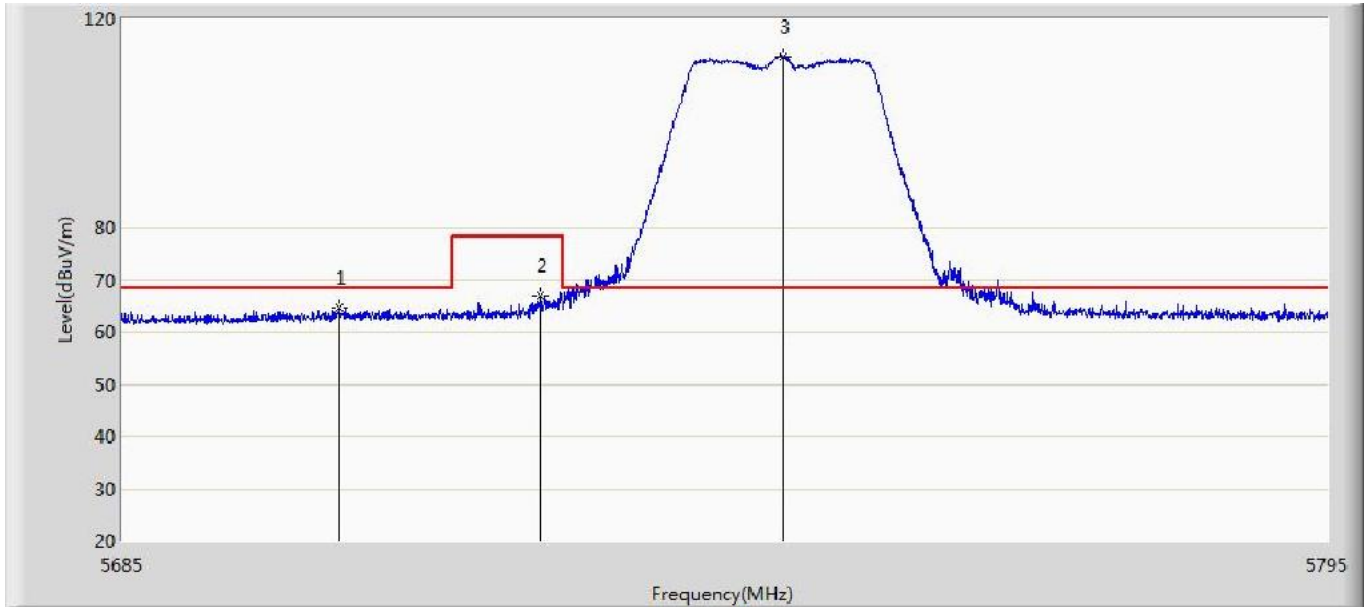

No	Mark	Frequency (MHz)	Measure Level (dBuV/m)	Reading Level (dBuV)	Over Limit (dB)	Limit (dBuV/m)	Factor (dB)	Type
1		5704.745	64.599	21.292	-3.701	68.300	43.307	PK
2		5722.950	66.887	23.614	-11.413	78.300	43.273	PK
3	*	5745.115	112.827	69.532	44.527	68.300	43.295	PK

Engineer: Frank	
Site: AC5	Time: 2015/12/05 - 13:40
Limit: FCC-15.407 new	Margin: 0
Probe: Horn_3117_00167055(1-18GHz)	Polarity: Horizontal
EUT: INTEGRATED GIMBAL CAMERA	Power: AC 120V/60Hz
Note: Mode2: Transmit at ch5825 by 802.11n(20MHz) ant1	

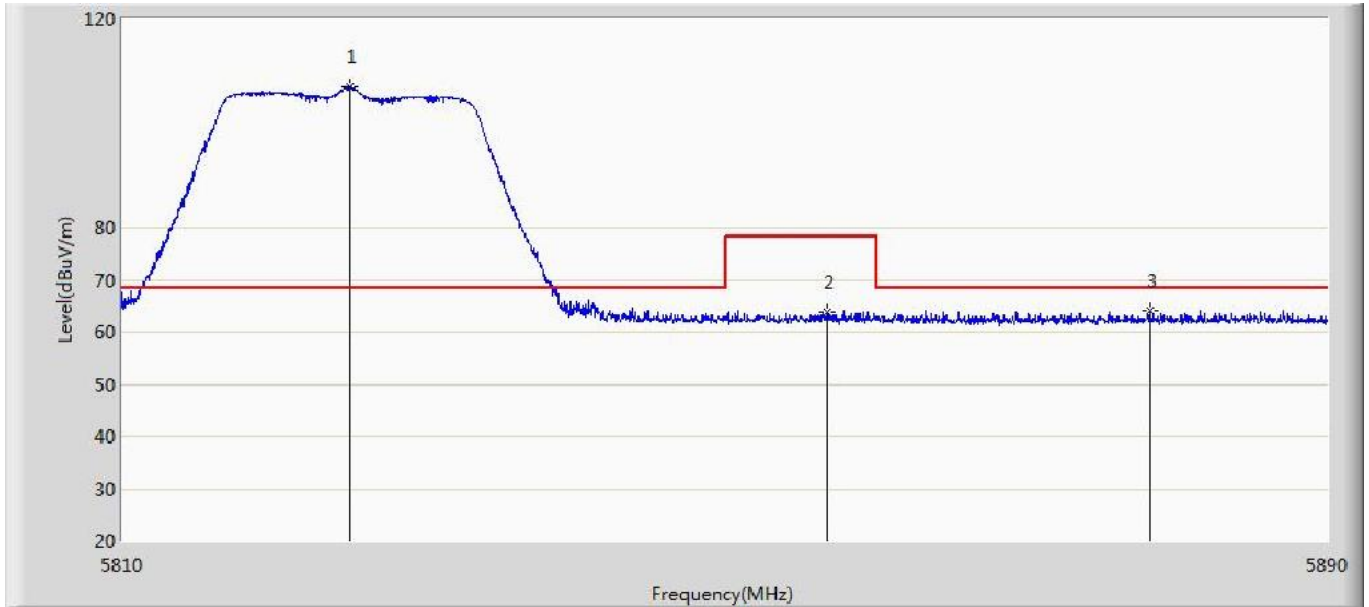

No	Mark	Frequency (MHz)	Measure Level (dBuV/m)	Reading Level (dBuV)	Over Limit (dB)	Limit (dBuV/m)	Factor (dB)	Type
1	*	5825.080	106.895	63.492	38.595	68.300	43.403	PK
2		5856.720	63.747	20.226	-14.553	78.300	43.521	PK
3		5878.160	63.965	20.354	-4.335	68.300	43.612	PK

Engineer: Frank	
Site: AC5	Time: 2015/12/05 - 13:42
Limit: FCC-15.407 new	Margin: 0
Probe: Horn_3117_00167055(1-18GHz)	Polarity: Vertical
EUT: INTEGRATED GIMBAL CAMERA	Power: AC 120V/60Hz
Note: Mode2: Transmit at ch5825 by 802.11n(20MHz) ant1	

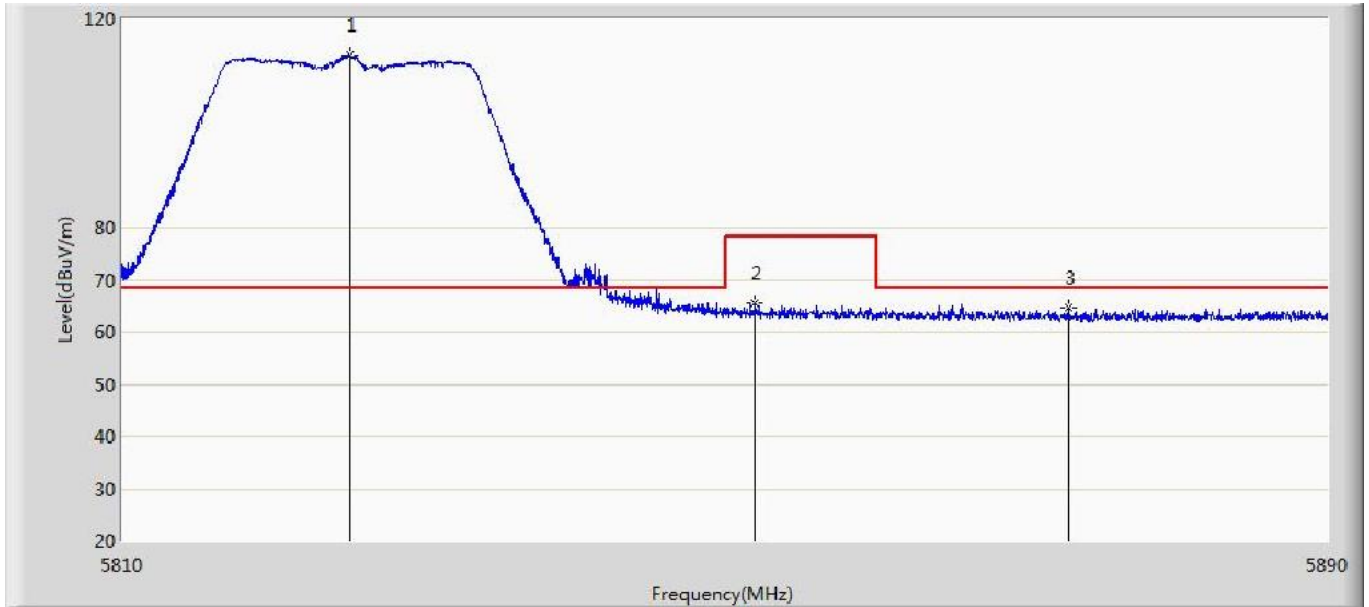

No	Mark	Frequency (MHz)	Measure Level (dBuV/m)	Reading Level (dBuV)	Over Limit (dB)	Limit (dBuV/m)	Factor (dB)	Type
1	*	5825.040	113.126	69.723	44.826	68.300	43.403	PK
2		5851.880	65.433	21.949	-12.867	78.300	43.484	PK
3		5872.800	64.525	20.930	-3.775	68.300	43.595	PK

Engineer: Frank	
Site: AC5	Time: 2015/12/05 - 13:44
Limit: FCC-15.407 new	Margin: 0
Probe: Horn_3117_00167055(1-18GHz)	Polarity: Horizontal
EUT: INTEGRATED GIMBAL CAMERA	Power: AC 120V/60Hz
Note: Mode2: Transmit at ch5745 by 802.11n(20MHz) ant2	

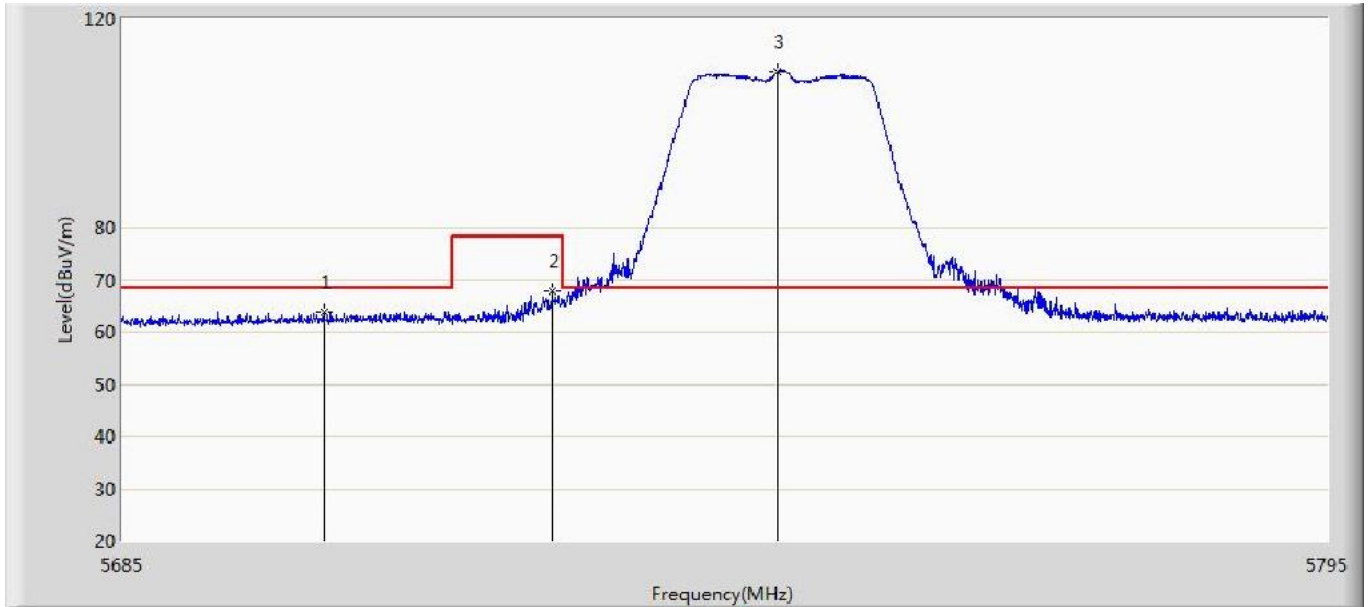

No	Mark	Frequency (MHz)	Measure Level (dBuV/m)	Reading Level (dBuV)	Over Limit (dB)	Limit (dBuV/m)	Factor (dB)	Type
1		5703.260	63.767	20.465	-4.533	68.300	43.302	PK
2		5724.050	67.690	24.421	-10.610	78.300	43.269	PK
3	*	5744.620	109.908	66.611	41.608	68.300	43.297	PK

Engineer: Frank	
Site: AC5	Time: 2015/12/05 - 13:47
Limit: FCC-15.407 new	Margin: 0
Probe: Horn_3117_00167055(1-18GHz)	Polarity: Vertical
EUT: INTEGRATED GIMBAL CAMERA	Power: AC 120V/60Hz
Note: Mode2: Transmit at ch5745 by 802.11n(20MHz) ant2	

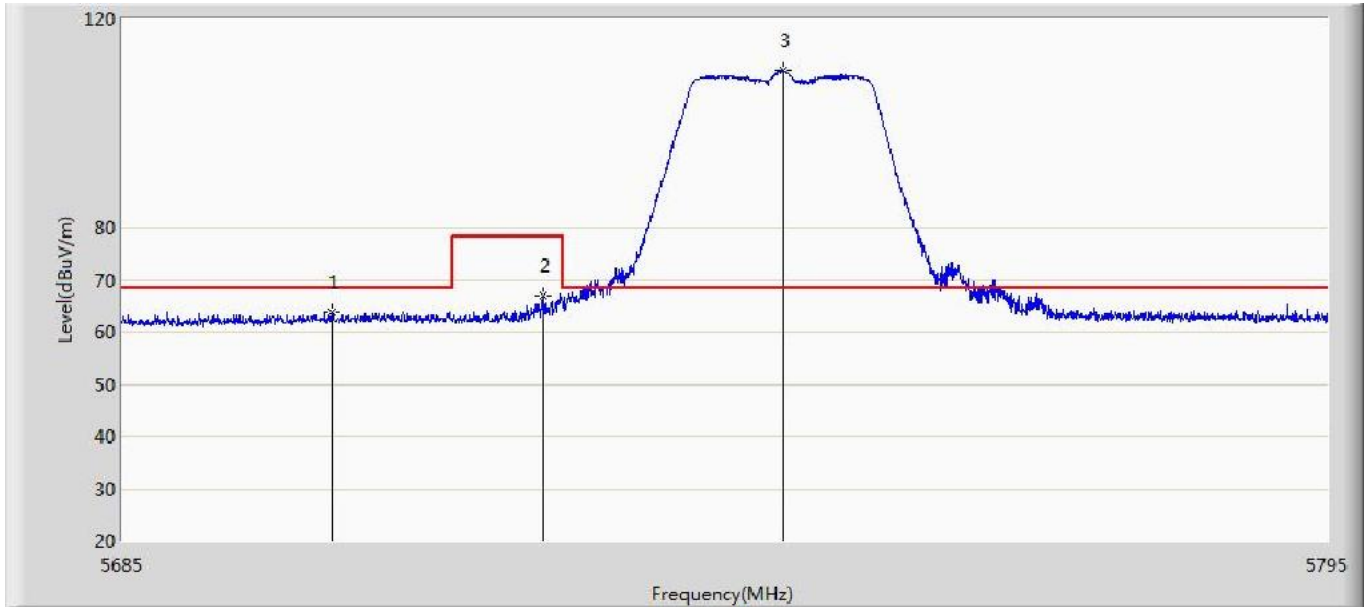

No	Mark	Frequency (MHz)	Measure Level (dBuV/m)	Reading Level (dBuV)	Over Limit (dB)	Limit (dBuV/m)	Factor (dB)	Type
1		5703.975	63.654	20.349	-4.646	68.300	43.305	PK
2		5723.280	66.952	23.680	-11.348	78.300	43.271	PK
3	*	5745.170	110.137	66.842	41.837	68.300	43.295	PK

Engineer: Frank	
Site: AC5	Time: 2015/12/05 - 13:52
Limit: FCC-15.407 new	Margin: 0
Probe: Horn_3117_00167055(1-18GHz)	Polarity: Horizontal
EUT: INTEGRATED GIMBAL CAMERA	Power: AC 120V/60Hz
Note: Mode2: Transmit at ch5825 by 802.11n(20MHz) ant2	

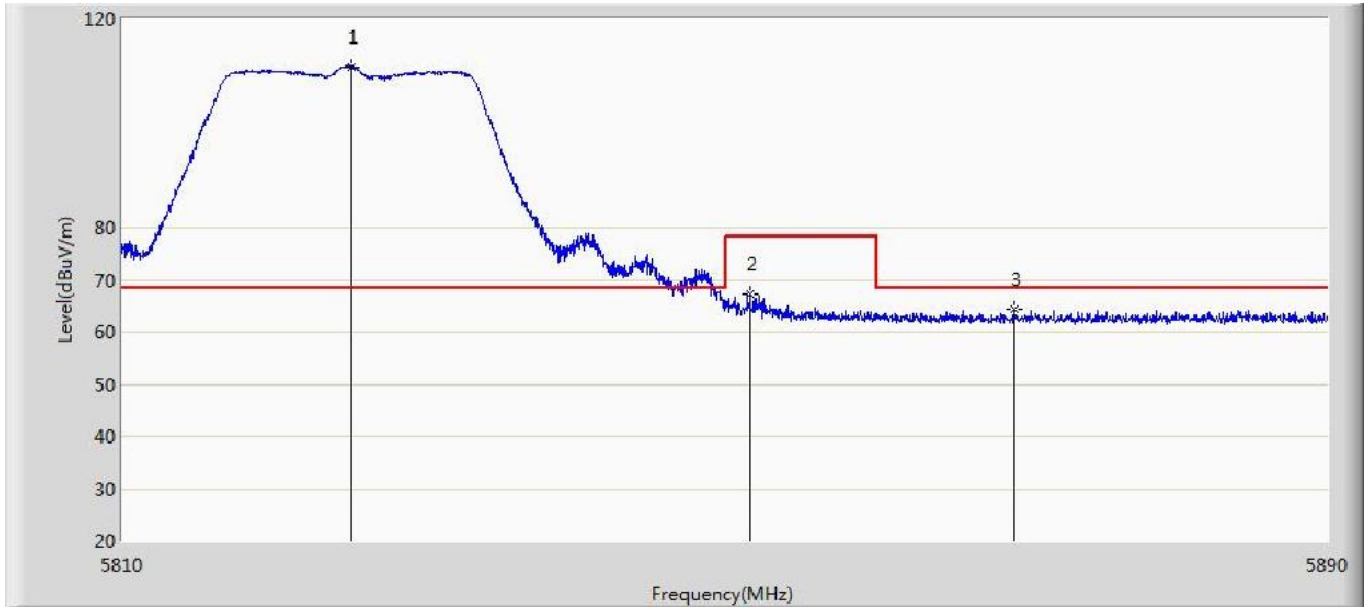

No	Mark	Frequency (MHz)	Measure Level (dBuV/m)	Reading Level (dBuV)	Over Limit (dB)	Limit (dBuV/m)	Factor (dB)	Type
1	*	5825.160	110.857	67.454	42.557	68.300	43.403	PK
2		5851.560	67.284	23.803	-11.016	78.300	43.481	PK
3		5869.120	64.385	20.802	-3.915	68.300	43.583	PK

Engineer: Frank	
Site: AC5	Time: 2015/12/05 - 13:53
Limit: FCC-15.407 new	Margin: 0
Probe: Horn_3117_00167055(1-18GHz)	Polarity: Vertical
EUT: INTEGRATED GIMBAL CAMERA	Power: AC 120V/60Hz
Note: Mode2: Transmit at ch5825 by 802.11n(20MHz) ant2	

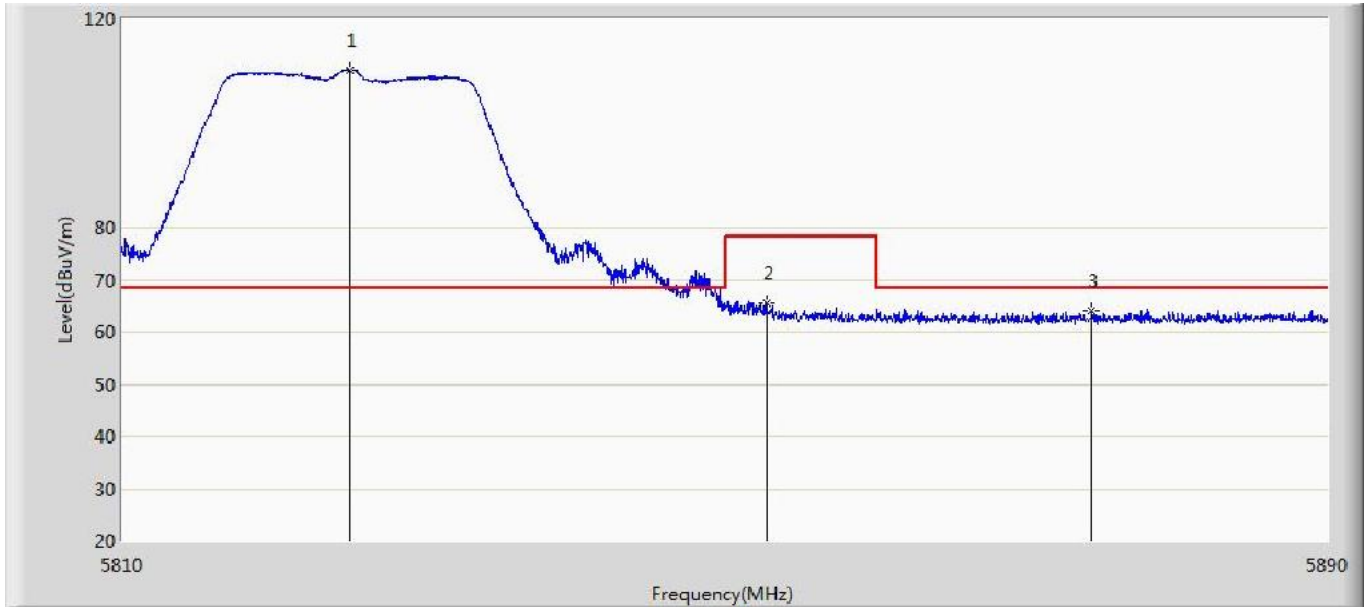

No	Mark	Frequency (MHz)	Measure Level (dBuV/m)	Reading Level (dBuV)	Over Limit (dB)	Limit (dBuV/m)	Factor (dB)	Type
1	*	5825.040	110.271	66.868	41.971	68.300	43.403	PK
2		5852.640	65.516	22.027	-12.784	78.300	43.490	PK
3		5874.320	64.186	20.586	-4.114	68.300	43.599	PK

Engineer: Frank	
Site: AC5	Time: 2015/12/05 - 13:58
Limit: FCC-15.407 new	Margin: 0
Probe: Horn_3117_00167055(1-18GHz)	Polarity: Horizontal
EUT: INTEGRATED GIMBAL CAMERA	Power: AC 120V/60Hz
Note: Mode3: Transmit at ch5745 by 802.11n(40MHz) ant1	

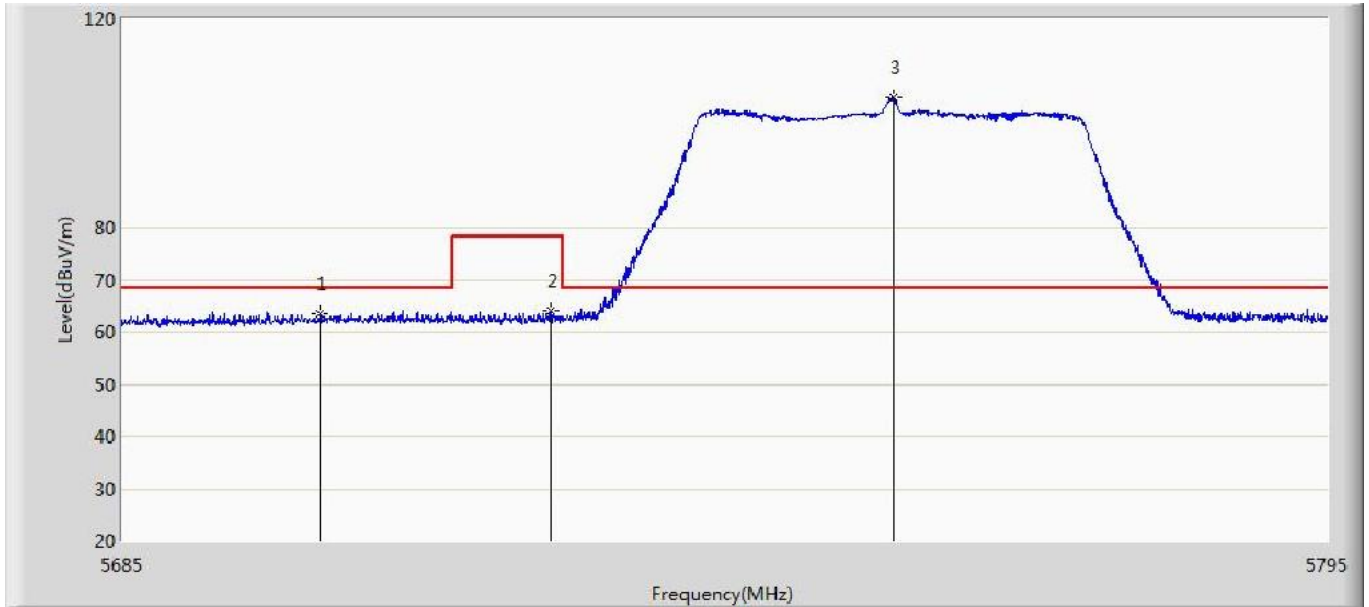

No	Mark	Frequency (MHz)	Measure Level (dBuV/m)	Reading Level (dBuV)	Over Limit (dB)	Limit (dBuV/m)	Factor (dB)	Type
1		5702.930	63.475	20.174	-4.825	68.300	43.301	PK
2		5723.885	64.174	20.904	-14.126	78.300	43.270	PK
3	*	5755.180	104.843	61.583	36.543	68.300	43.259	PK

Engineer: Frank	
Site: AC5	Time: 2015/12/05 - 14:00
Limit: FCC-15.407 new	Margin: 0
Probe: Horn_3117_00167055(1-18GHz)	Polarity: Vertical
EUT: INTEGRATED GIMBAL CAMERA	Power: AC 120V/60Hz
Note: Mode3: Transmit at ch5745 by 802.11n(40MHz) ant1	

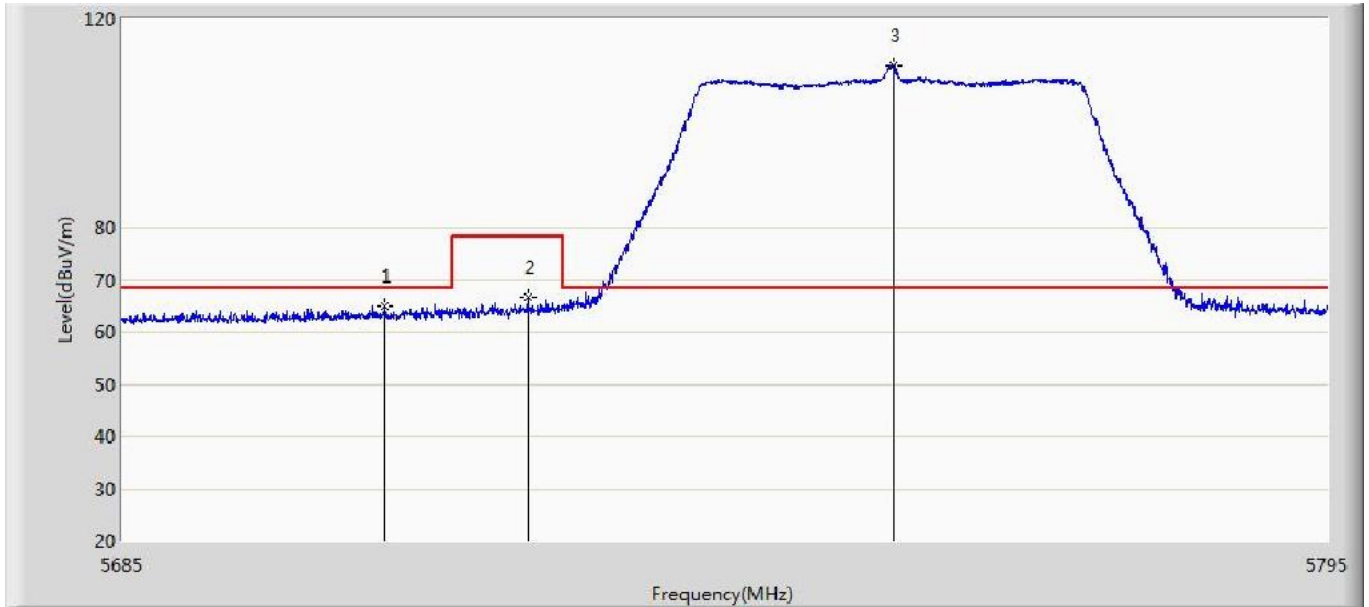

No	Mark	Frequency (MHz)	Measure Level (dBuV/m)	Reading Level (dBuV)	Over Limit (dB)	Limit (dBuV/m)	Factor (dB)	Type
1		5708.870	64.964	21.644	-3.336	68.300	43.320	PK
2		5721.795	66.680	23.403	-11.620	78.300	43.277	PK
3	*	5755.235	111.155	67.896	42.855	68.300	43.259	PK

Engineer: Frank	
Site: AC5	Time: 2015/12/05 - 14:05
Limit: FCC-15.407 new	Margin: 0
Probe: Horn_3117_00167055(1-18GHz)	Polarity: Horizontal
EUT: INTEGRATED GIMBAL CAMERA	Power: AC 120V/60Hz
Note: Mode3: Transmit at ch5795 by 802.11n(40MHz) ant1	

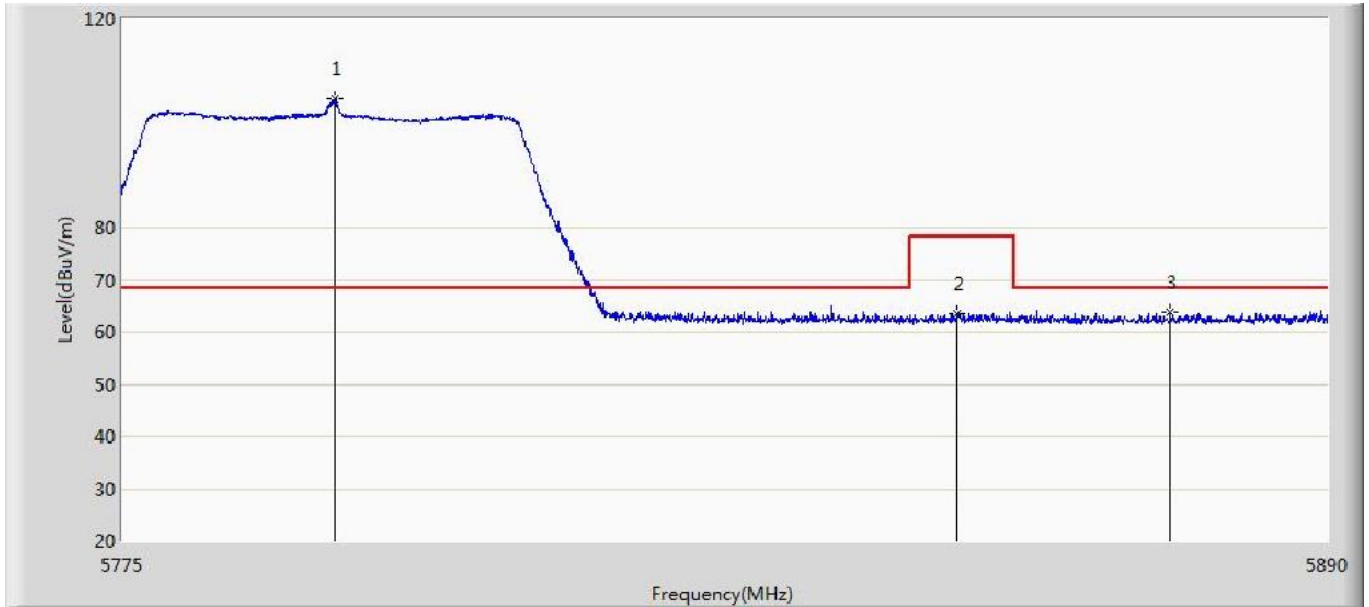

No	Mark	Frequency (MHz)	Measure Level (dBuV/m)	Reading Level (dBuV)	Over Limit (dB)	Limit (dBuV/m)	Factor (dB)	Type
1	*	5795.125	104.598	61.306	36.298	68.300	43.292	PK
2		5854.522	63.377	19.873	-14.923	78.300	43.503	PK
3		5874.935	63.815	20.214	-4.485	68.300	43.601	PK

Engineer: Frank	
Site: AC5	Time: 2015/12/05 - 14:06
Limit: FCC-15.407 new	Margin: 0
Probe: Horn_3117_00167055(1-18GHz)	Polarity: Vertical
EUT: INTEGRATED GIMBAL CAMERA	Power: AC 120V/60Hz
Note: Mode3: Transmit at ch5795 by 802.11n(40MHz) ant1	

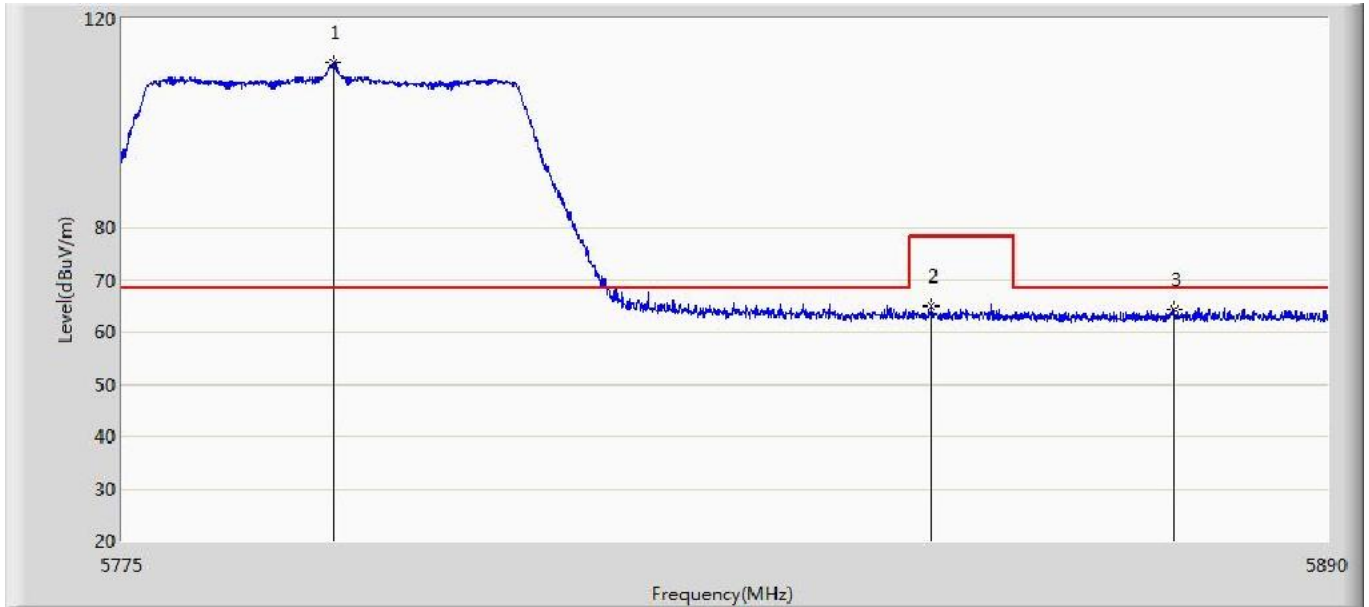

No	Mark	Frequency (MHz)	Measure Level (dBuV/m)	Reading Level (dBuV)	Over Limit (dB)	Limit (dBuV/m)	Factor (dB)	Type
1	*	5795.010	111.501	68.210	43.201	68.300	43.291	PK
2		5852.050	65.045	21.560	-13.255	78.300	43.485	PK
3		5875.337	64.362	20.759	-3.938	68.300	43.603	PK

Engineer: Frank	
Site: AC5	Time: 2015/12/05 - 14:10
Limit: FCC-15.407 new	Margin: 0
Probe: Horn_3117_00167055(1-18GHz)	Polarity: Horizontal
EUT: INTEGRATED GIMBAL CAMERA	Power: AC 120V/60Hz
Note: Mode3: Transmit at ch5745 by 802.11n(40MHz) ant2	

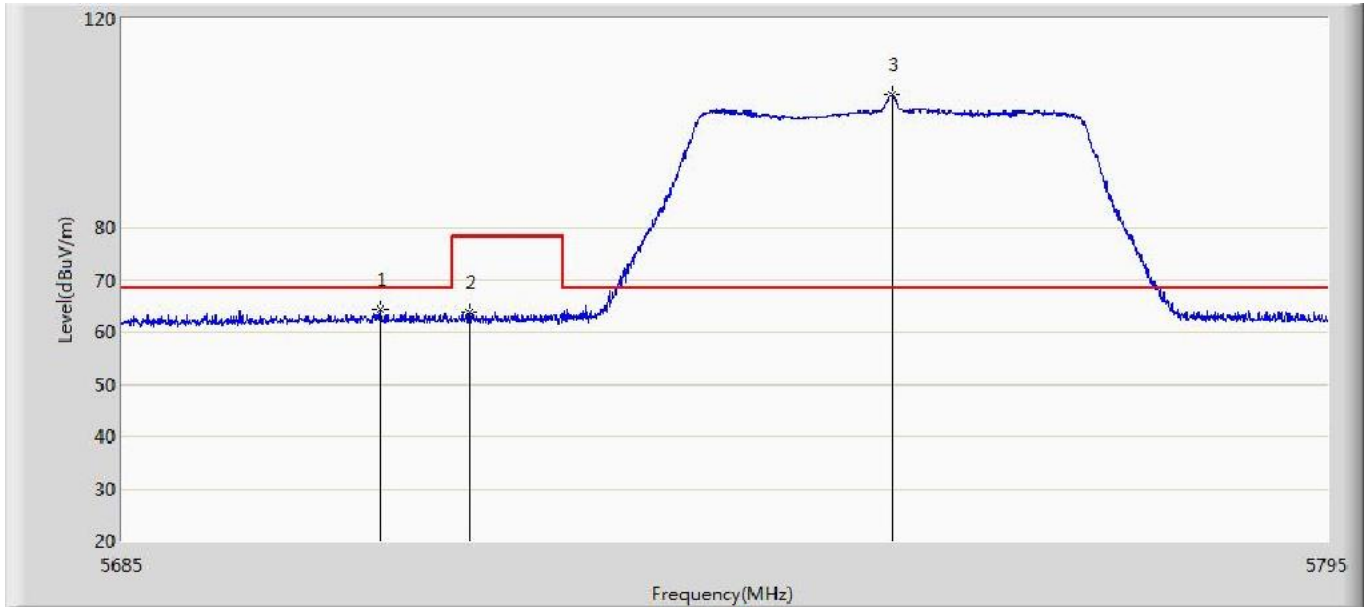

No	Mark	Frequency (MHz)	Measure Level (dBuV/m)	Reading Level (dBuV)	Over Limit (dB)	Limit (dBuV/m)	Factor (dB)	Type
1		5708.375	64.278	20.960	-4.022	68.300	43.318	PK
2		5716.515	63.785	20.490	-14.515	78.300	43.295	PK
3	*	5755.125	105.501	62.241	37.201	68.300	43.260	PK

Engineer: Frank	
Site: AC5	Time: 2015/12/05 - 14:12
Limit: FCC-15.407 new	Margin: 0
Probe: Horn_3117_00167055(1-18GHz)	Polarity: Vertical
EUT: INTEGRATED GIMBAL CAMERA	Power: AC 120V/60Hz
Note: Mode3: Transmit at ch5745 by 802.11n(40MHz) ant2	

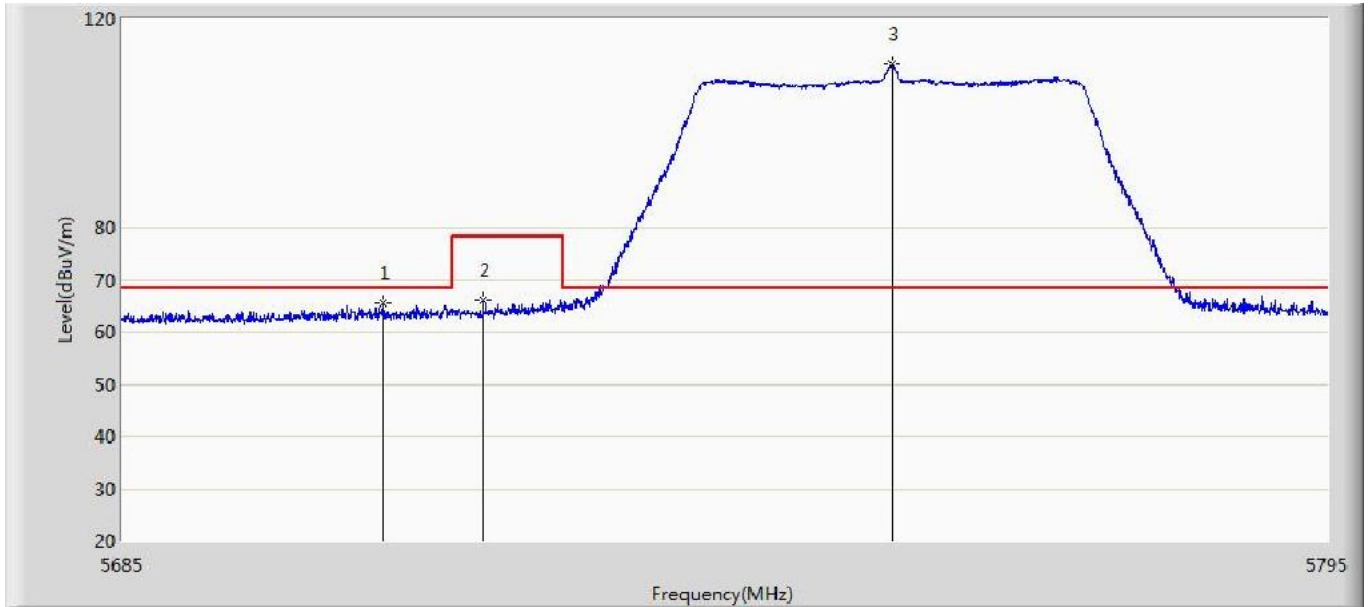

No	Mark	Frequency (MHz)	Measure Level (dBuV/m)	Reading Level (dBuV)	Over Limit (dB)	Limit (dBuV/m)	Factor (dB)	Type
1		5708.705	65.420	22.101	-2.880	68.300	43.320	PK
2		5717.725	66.030	22.739	-12.270	78.300	43.291	PK
3	*	5755.125	111.264	68.004	42.964	68.300	43.260	PK

Engineer: Frank	
Site: AC5	Time: 2015/12/05 - 14:15
Limit: FCC-15.407 new	Margin: 0
Probe: Horn_3117_00167055(1-18GHz)	Polarity: Horizontal
EUT: INTEGRATED GIMBAL CAMERA	Power: AC 120V/60Hz
Note: Mode3: Transmit at ch5795 by 802.11n(40MHz) ant2	

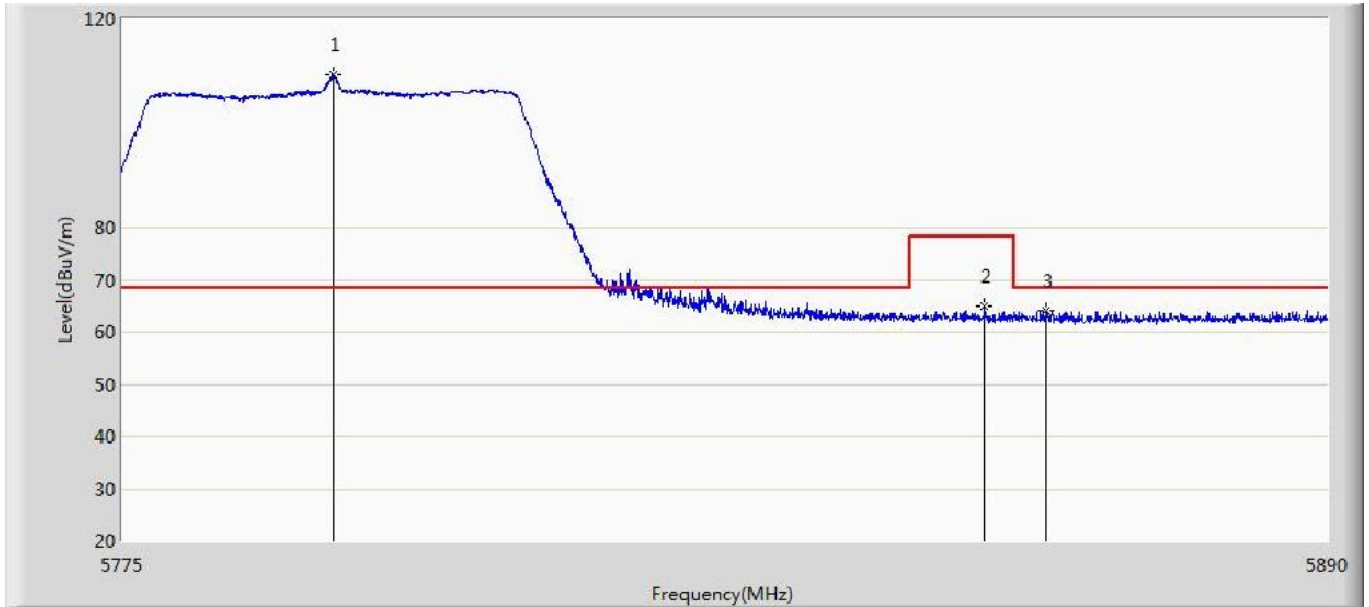

No	Mark	Frequency (MHz)	Measure Level (dBuV/m)	Reading Level (dBuV)	Over Limit (dB)	Limit (dBuV/m)	Factor (dB)	Type
1	*	5795.010	109.240	65.949	40.940	68.300	43.291	PK
2		5857.110	64.837	21.313	-13.463	78.300	43.524	PK
3		5862.975	64.152	20.588	-4.148	68.300	43.564	PK

Engineer: Frank	
Site: AC5	Time: 2015/12/05 - 14:16
Limit: FCC-15.407 new	Margin: 0
Probe: Horn_3117_00167055(1-18GHz)	Polarity: Vertical
EUT: INTEGRATED GIMBAL CAMERA	Power: AC 120V/60Hz
Note: Mode3: Transmit at ch5795 by 802.11n(40MHz) ant2	

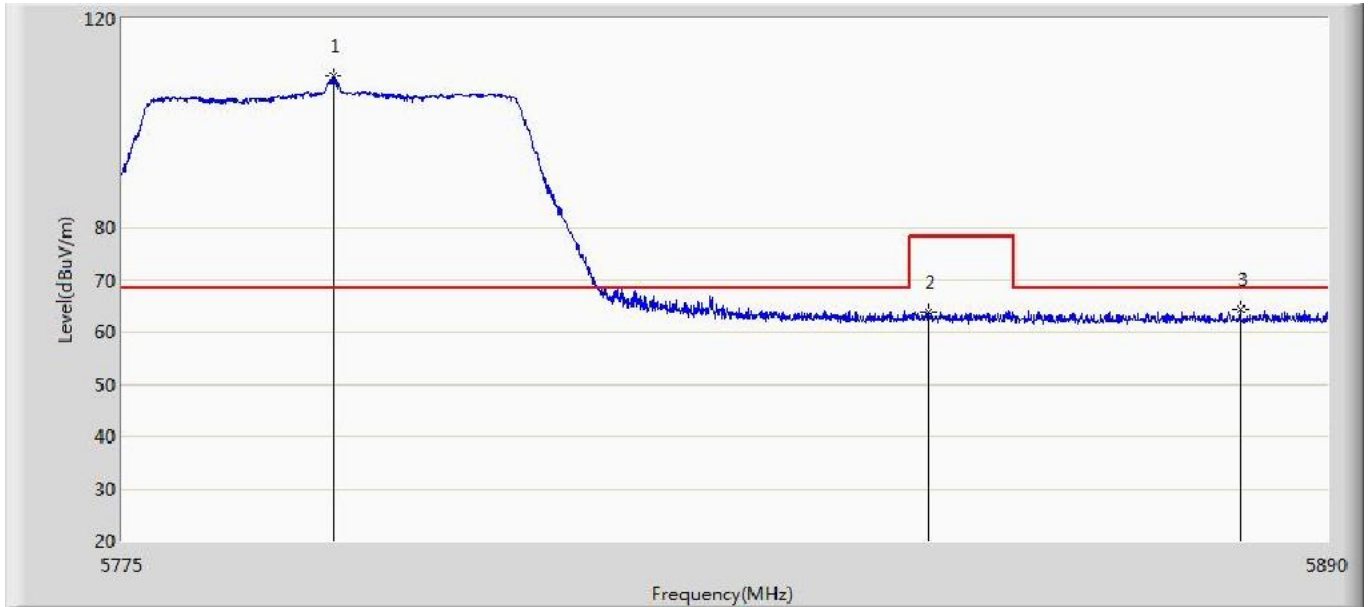

No	Mark	Frequency (MHz)	Measure Level (dBuV/m)	Reading Level (dBuV)	Over Limit (dB)	Limit (dBuV/m)	Factor (dB)	Type
1	*	5794.953	108.848	65.557	40.548	68.300	43.291	PK
2		5851.647	63.648	20.166	-14.652	78.300	43.481	PK
3		5881.663	64.402	20.799	-3.898	68.300	43.604	PK

10. Frequency Stability

10.1. Test Equipment

Frequency Stability / TR-8

Instrument	Manufacturer	Type No.	Serial No.	Cali. Due Date
Spectrum Analyzer	Agilent	E4446A	MY45300103	2017.01.04
AC Power Supply	IDRC	CF-500TP	979422	2016.09.16
DC Power Supply	IDRC	CD-035-020PR	977272	2016.09.16 </td
Programmable Temperature & Humidity Chamber	Gaoyu	TH-1P-B	WIT-05121302	2017.01.04
Temperature/Humidity Meter	zhicheng	ZC1-2	TR8-TH	2016.04.09

Note: All equipments are calibrated with traceable calibrations. Each calibration is traceable to the national or international standards.

10.2. Test Setup

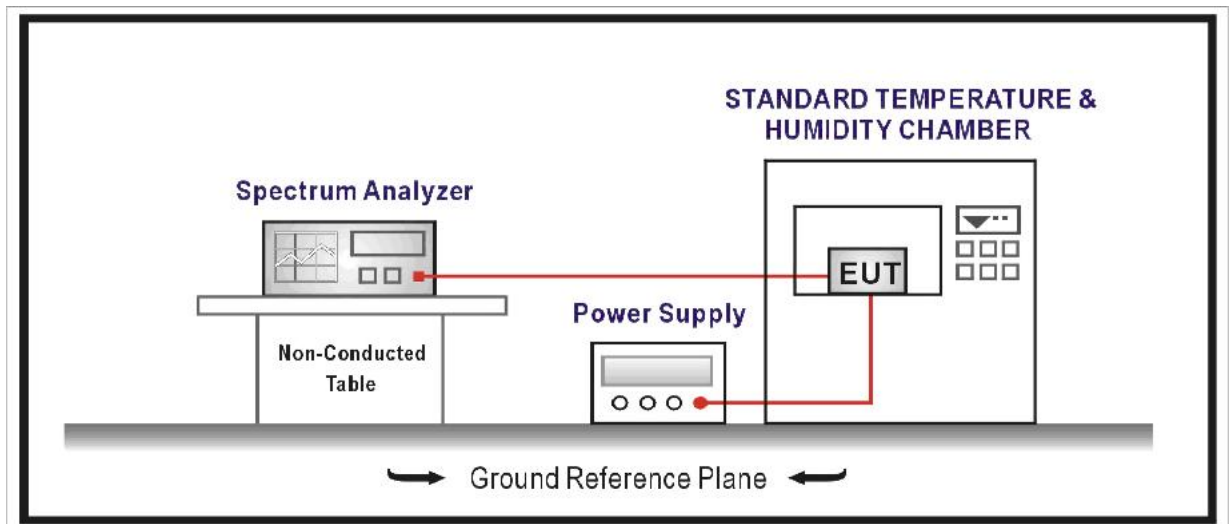

10.3. Limit

For FCC&IC

Manufactures of U-NII devices are responsible for ensuring frequency stability such that an emission is maintained within the band of operation under all conditions of normal operation as specified in the user's manual.

10.4. Test Procedure

Frequency Stability Under Temperature Variations:

The equipment under test was connected to an external AC or DC power supply and input rated voltage. RF output was connected to a frequency counter or spectrum analyzer via feed through attenuators. The EUT was placed inside the temperature chamber. Set the spectrum analyzer RBW low enough to obtain the desired frequency resolution and measure EUT 20°C operating frequency as reference frequency. Turn EUT off and set the chamber temperature to highest. After the temperature stabilized for approximately 30 minutes recorded the frequency. Repeat step measure with 10°C decreased per stage until the lowest temperature reached.

Frequency Stability Under Voltage Variations:

Set chamber temperature to 20°C. Use a variable AC power supply / DC power source to power the EUT and set the voltage to rated voltage. Set the spectrum analyzer RBW low enough to obtain the desired frequency resolution and recorded the frequency.

Reduce the input voltage to specify extreme voltage variation ($\pm 15\%$) and endpoint, record the maximum frequency change.

10.5. Uncertainty

The measurement uncertainty is defined as ± 100 Hz

10.6. Test Result

Product	:	INTEGRATED GIMBAL CAMERA
Test Item	:	Frequency Stability
Test Site	:	TR-8
Test Mode	:	Carrier Transmit

Frequency Stability under Temperature

Temperature Interval (°C)	Test Frequency (MHz)	Deviation (Hz)
-30	5805.000	-123
-20	5805.000	130
-10	5805.000	-96
0	5805.000	-117
10	5805.000	114
20	5805.000	113
30	5805.000	125
40	5805.000	134
50	5805.000	-99

Frequency Stability under Voltage

DC Voltage (V)	Test Frequency (MHz)	Deviation (Hz)
12	5805.000	99
16	5805.000	-102
18	5805.000	115

Note: For this test item, the modulation of this mode we have evaluated two antennas, presented data in the report is the worst case.

_____ The End _____