

Quadcopter Manual

Please read and keep this manual carefully before using.

Attention

- Quadcopter could be dangerous; it is designed to be used by adults over 18 years old
- Keep enough distance between Quadcopter and people, animals, trees, vehicles or buildings when using it.
- Be away from dangerous circumstances such as airports, railways, high ways, tall buildings or electric wires etc.
- According to relevant laws and regulations, the flying height of this Quadcopter should be below 120m and the distance between the operator should be under 500m.
- Users should take responsibility for any damage of components or system causing by not following this user guide.

Scan & Install Quadcopter App



- Beginners Guide
- Online Map
- Real-time Aerial Videos and Images

Products & Accessories

1. Quadcopter

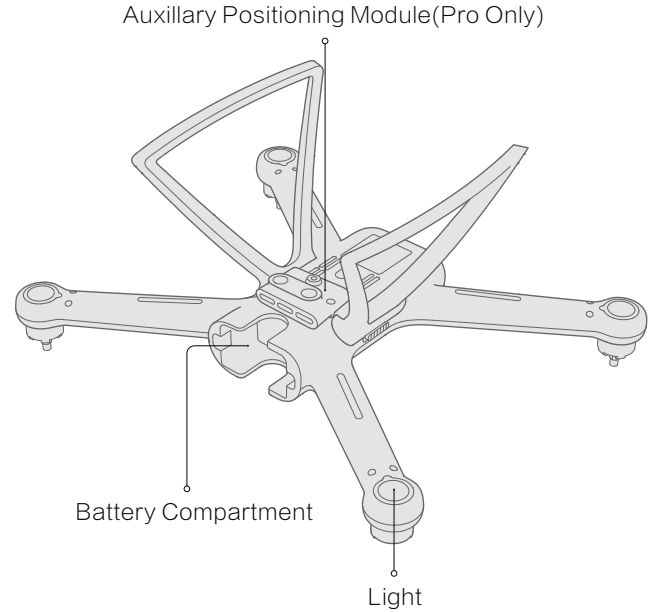
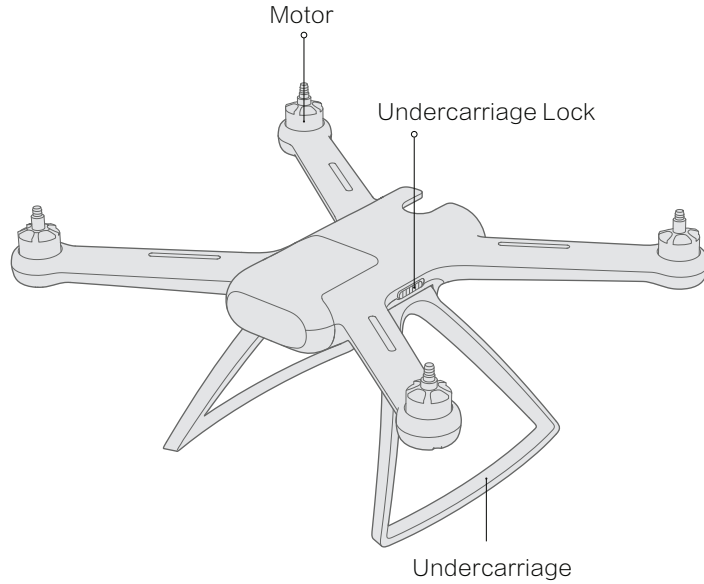

Products & Accessories

2. Radio Control

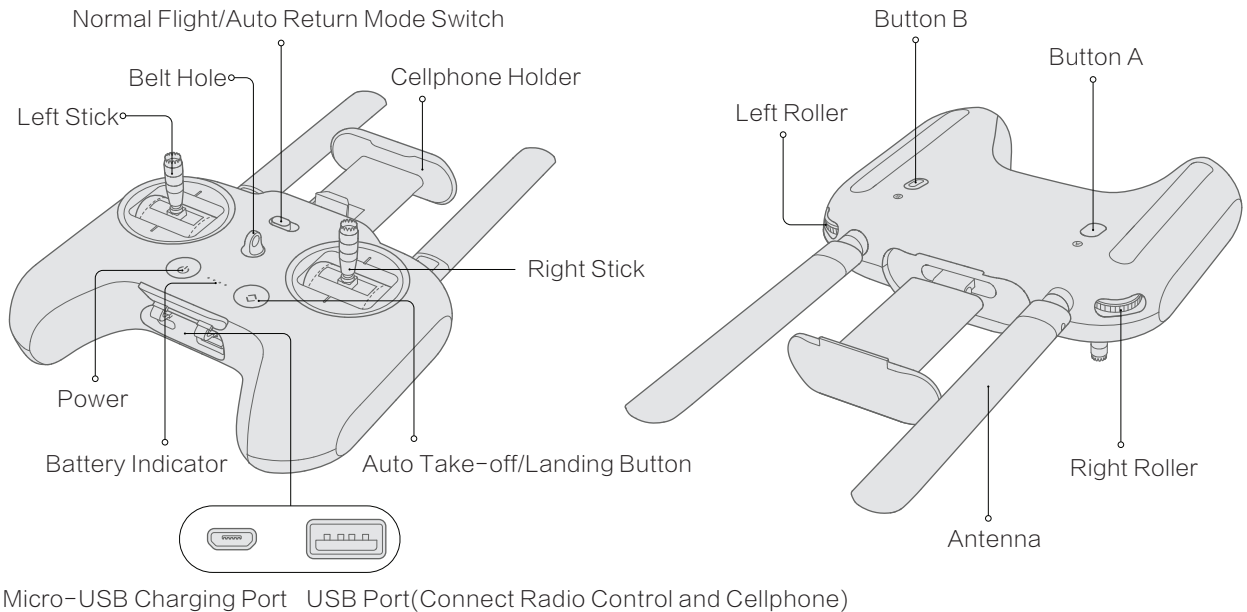

Products & Accessories

3. Integrated Gyro-Stabilized Gimbal & Camera (Pro Only)

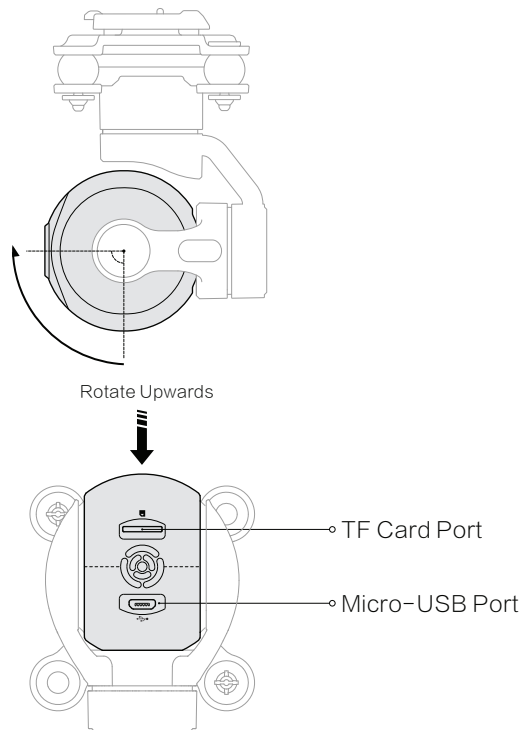
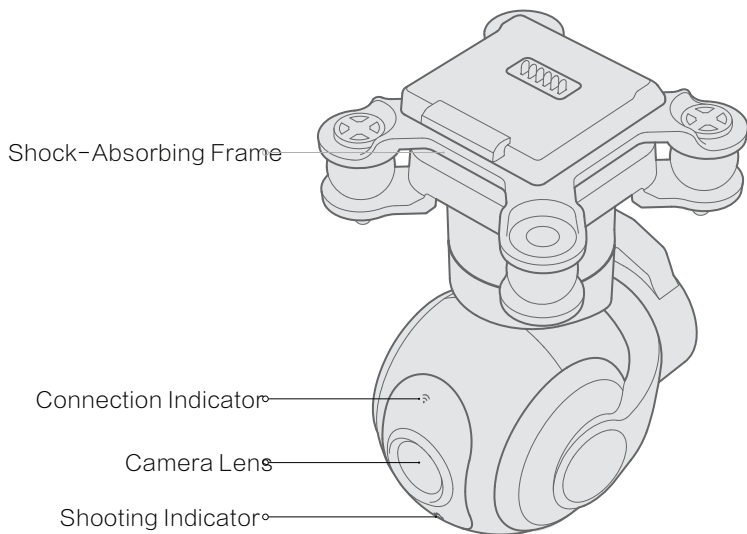

Products & Accessories

4. Accessories for Quadcopter

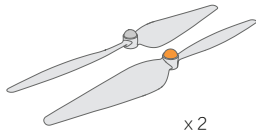

x 2

Self-Tightening Propellers
Clockwise & Anti-Clockwise

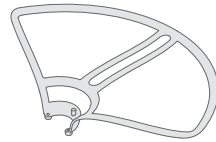

x 4

Protective Frame

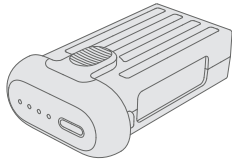

Quadcopter Battery

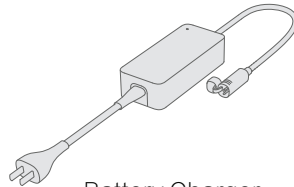

Battery Charger

5. Tool Box

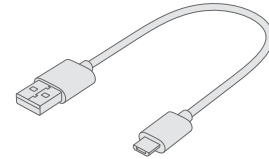

USB Cable

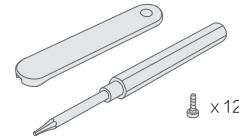

1 wrench, 1 screwdriver and screws

Prepare

1. Charge the Quadcopter Battery

- Connect charger to power to charge the battery.
- After charging is completed, indicator will be turned off.

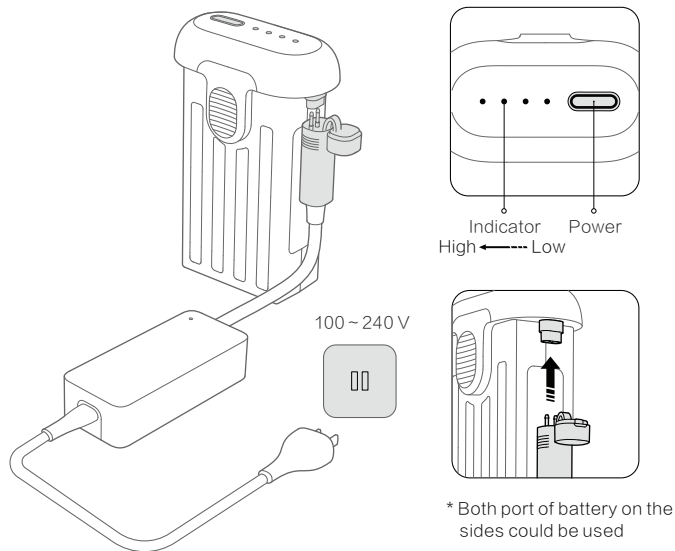

2. Charge the Radio Control

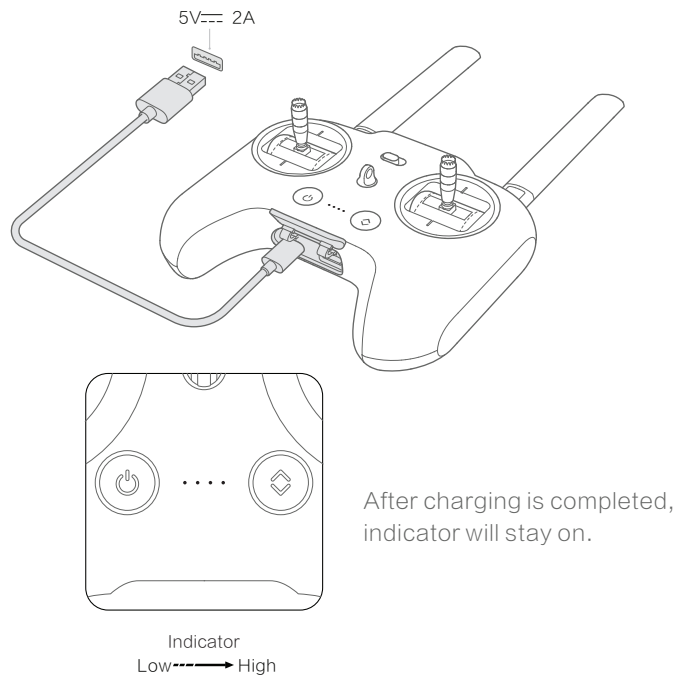

Assemble & Disassemble

1. Assemble the Quadcopter

a. Undercarriage

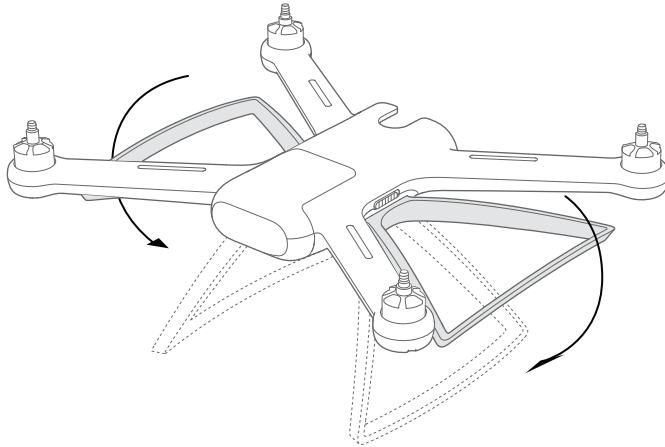

Turn the undercarriage till it clicks;
Undercarriage will be locked automatically.

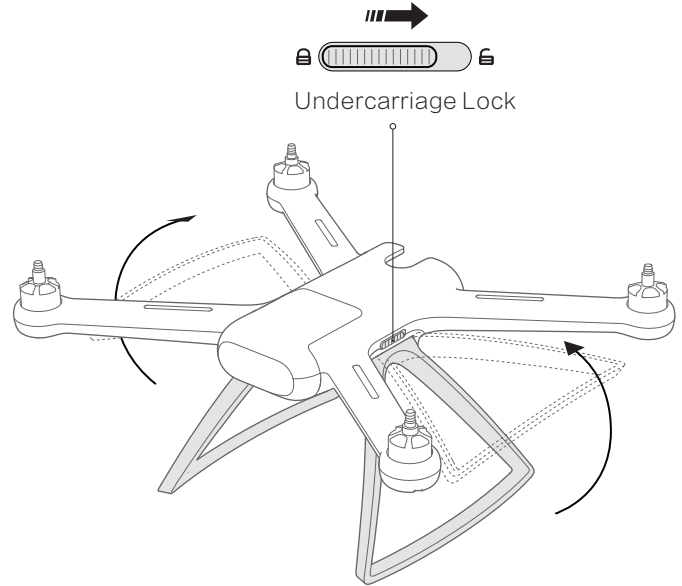

Turn and hold the undercarriage lock to unlock
position;
Pull up the undercarriage.

Assemble & Disassemble

b. Integrated Gimbal & Camera(Pro Only)

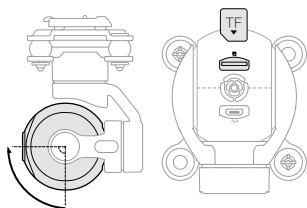

Rotate the camera upwards;
Plug in TF Card.

* Please choose TF cards of mainstream brands, Class 10 and 16G at least.

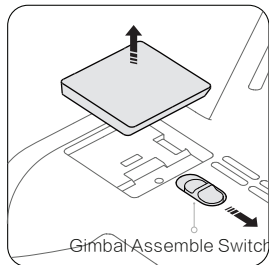

Turn and keep the Gimbal Assemble Switch;
Remove the gimbal cover.

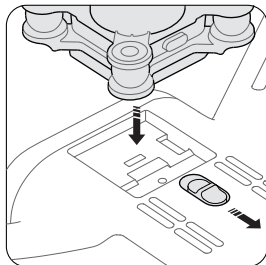

Keep the Gimbal Assemble Switch and assemble the gimbal.

c. Protective Frame

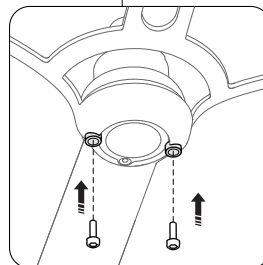
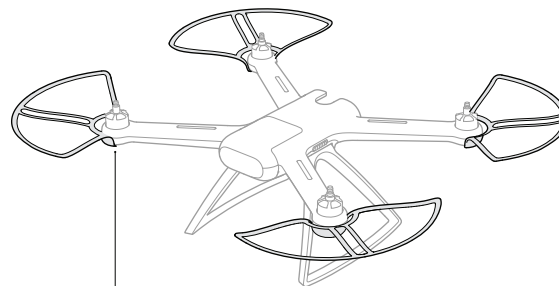

- Use screws and screwdriver in the Tool Box to assemble.
- Every Protective Frame needs 2 screws.

Assemble & Disassemble

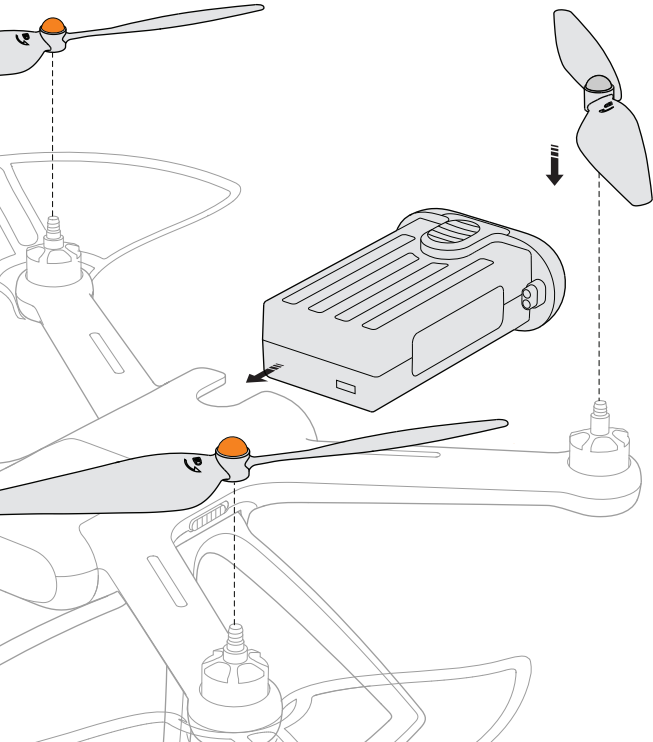

d. Propellers

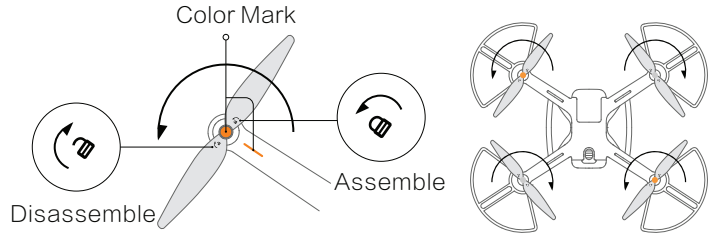

- Put propellers on the motors by different Color Marks;
- Rotate propellers by assemble directions.
- Propellers will tighten automatically during flying.

5. Quadcopter Battery

- Push the Quadcopter Battery hard into the Battery Compartment till it clicks.
- Push the Battery Assemble Switch then the Battery could be pulled out

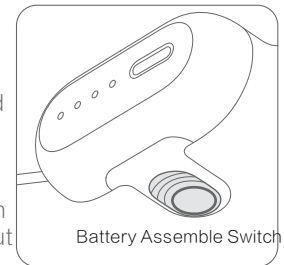

Assemble & Disassemble

1. Connect Radio Control & Cellphone

a. Put Down the Antennas

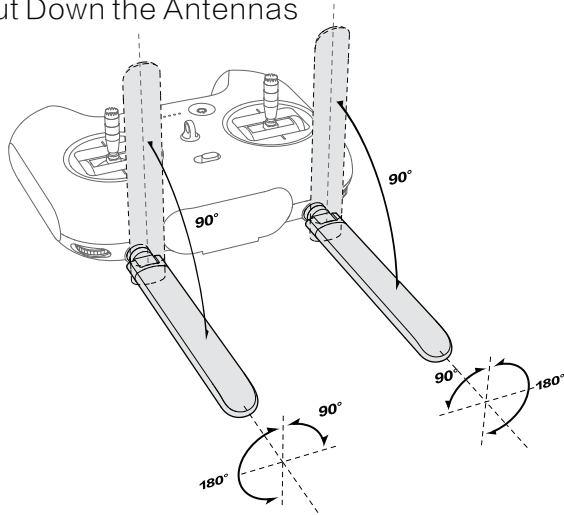

- The rotatable angle of antennas is as this figure.
- Turn antennas 90 degree to Radio Control.

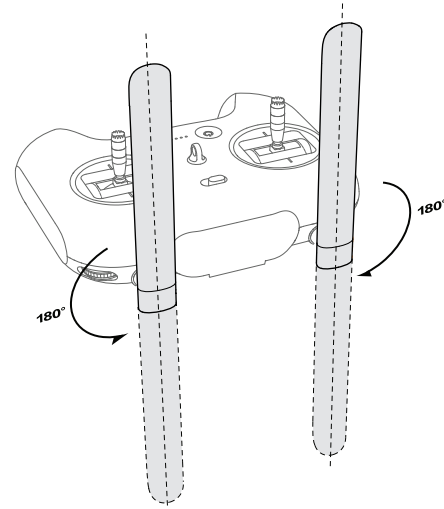

Turn antennas upside down and keep parallel.

Assemble & Disassemble

b. Connect Radio Control & Cellphone

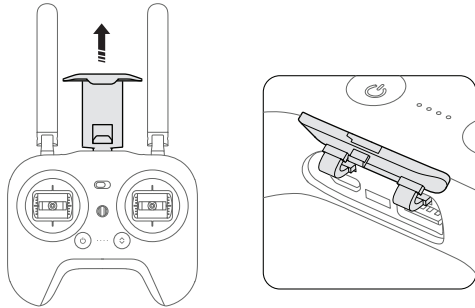

Pull out Cellphone Holder. Open the cover on bottom.

- Pull out Cellphone Holder; the lower edge of holder will pop up.
- Set cellphone on the holder; Be careful not to hit the power of cellphone.
- Open the cover on bottom of Radio Control.
- Use the USB Cable to connect Radio Control and

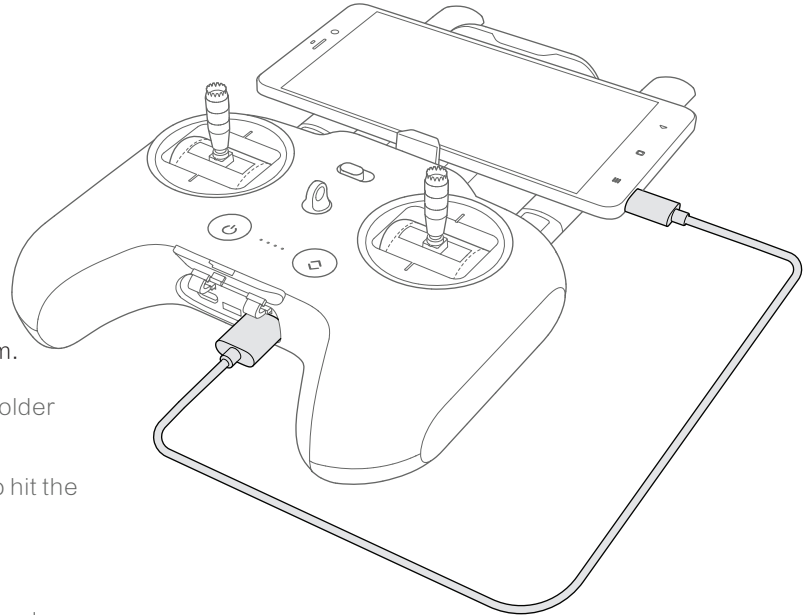

Operation Guide

1. Head Direction

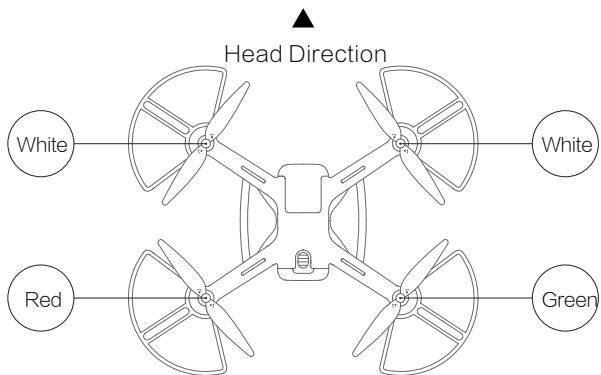

- The color of Quadcopter Lights is as this figure.
- The Head Direction is in between two white lights.

2. Power on Quadcopter & Radio Control

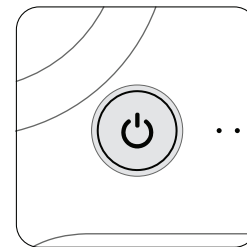
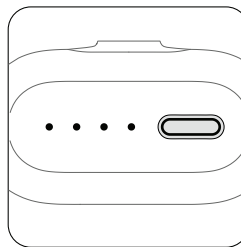
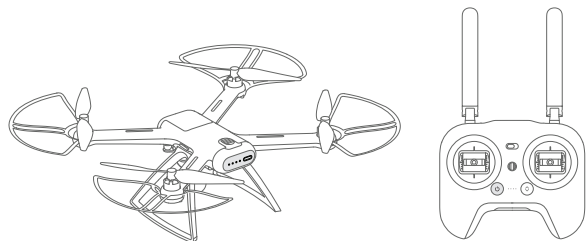

- Press power once to check the electrical quantity.
- Press power once, then long-press for 2 seconds to power on.
on/off.

Operation Guide

3. Radio Control Sticks

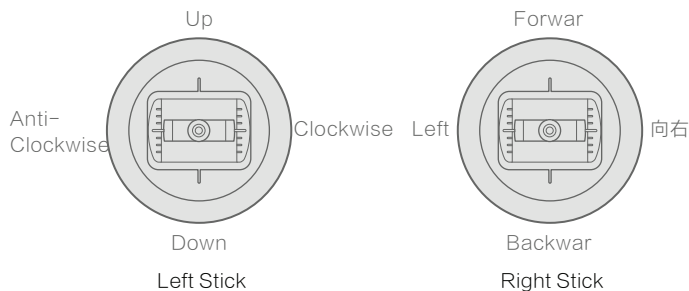
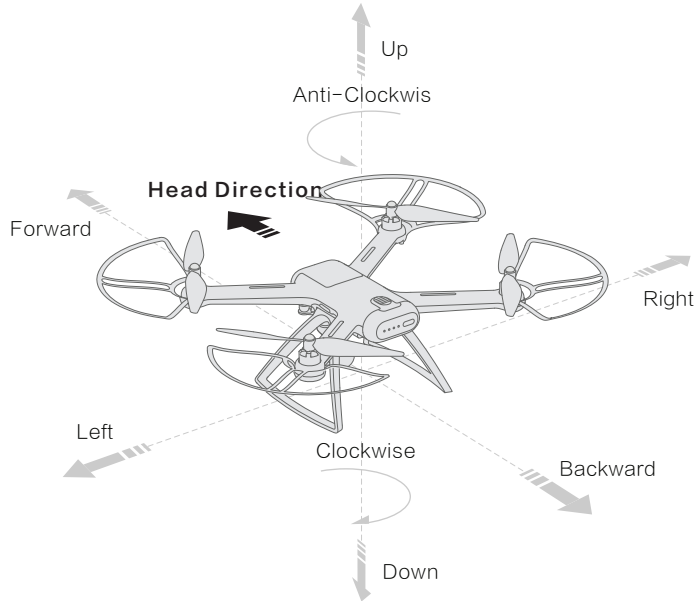

By default, left stick is used to control Quadcopter to move up and down, a.k.a "American Way".

The way of control could be changed in App.

Operation Guide

4. Take-off & Landing by Radio Control

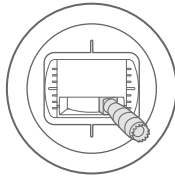

Left Stick

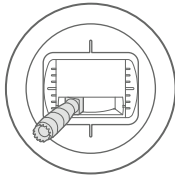

Right Stick

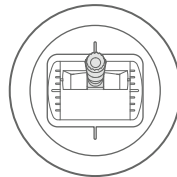

Push left stick upward slowly and steadily

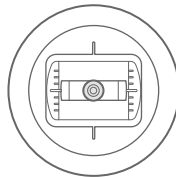

Pull
Slowly

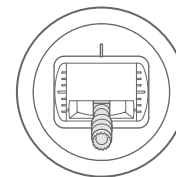

Left Stick

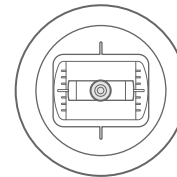

Right Stick

1. Pull two sticks to the max into shape V and hold for 3 seconds;
Propellers will start to rotate.
2. Release the stick after propellers' rotating.
3. Push left stick upward slowly and steadily over half;

1. Pull left stick downwards slowly and steadily;
Quadcopter will start to land.
2. Hold the stick downwards after the undercarriages touch the ground.
Propellers will stop in 5 seconds.

Operation Guide

5. Radio Control Shortcuts

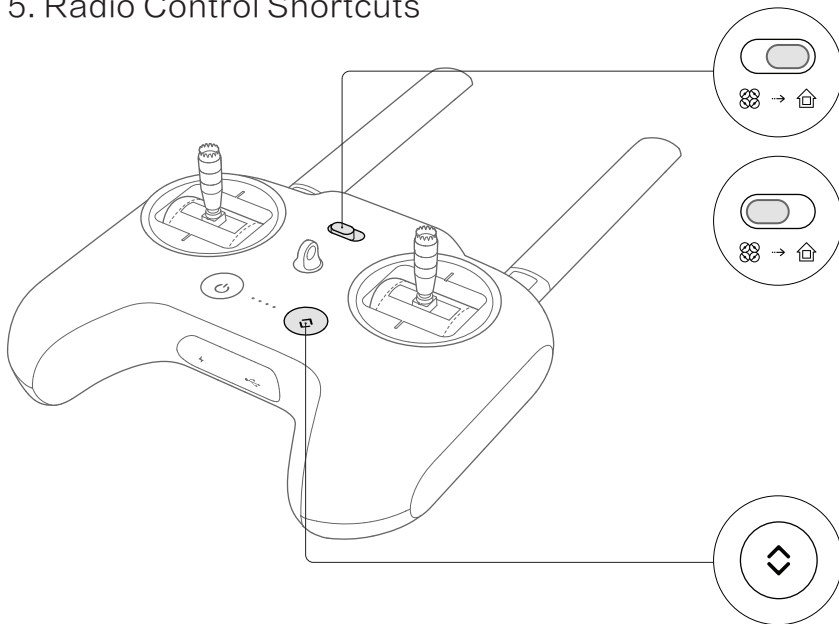

- When the Quadcopter is flying, turn Normal Flight/Auto Return Mode Switch to the right; Quadcopter will return near to the takeoff point and land automatically.

- During return, turn back the Switch to left; Quadcopter will hover.

- When the Light of Auto Take-off/Landing Button is white, the Button could be used for making the Quadcopter take off or land.

- When the Quadcopter is stopping at a flat surface, press the button once, then long-press for 2 seconds; Quadcopter will take off automatically.

- When the Quadcopter is flying, press the button once, then long-press for 2 seconds; Quadcopter will land automatically.

Operation Guide

6. Integrated Gimbal & Camera(Pro Only)

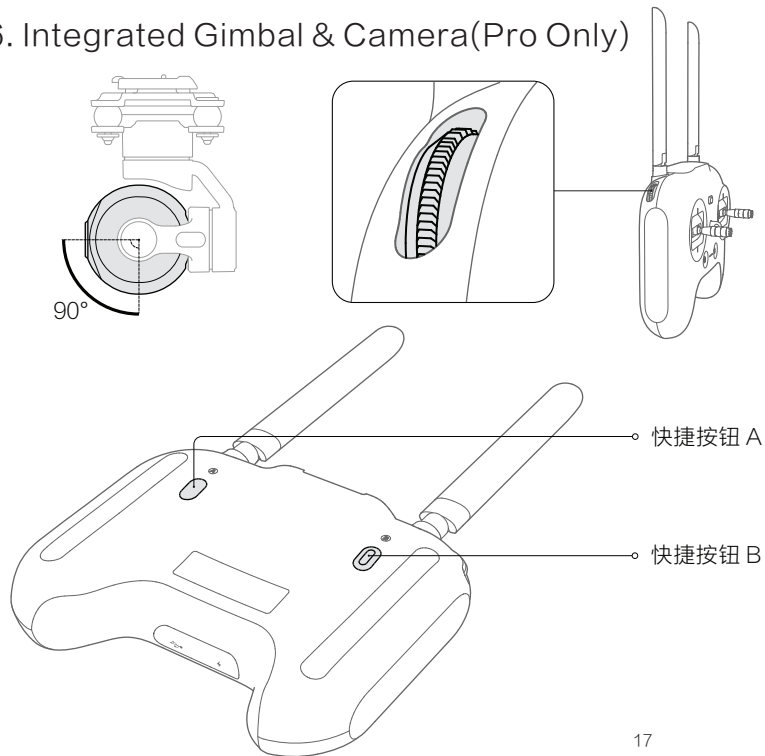

· Gimbal and camera will be turn on after poweing on the Quadcopter if assembled.

· Turn up and down the left roller of Radio Control, the camera lens will turn up and down in between the range as the figure.

· Release the left roller, camera lens will stay at the position.

· After turning on camera, the Butto A on Radio Control could be used to take a photo and the Button B could be used to take a video.

Operation Guide

7. Get Videos & Images

Use App to get real-time aerial videos and images, control camera and download to cellphone.

8. Adjust Quadcopter Head Lights Brightness

Turn up and down the right roller of Radio Control to adjust two white lights' brightness on the head of Quadcopter.

9. Operation Tips

At any moment during Quadcopter' flying, release two stick of Radio Control; Quadcopter will hover.

Maintain & Calibrate

1. Propellers

Propellers are fragile.

Replace propellers with new ones immediately when it abrades to prevent affecting the flying performance.

2. Self-Test & Compass Calibration

- Quadcopter and Radio Control will self test after power on.
- Check self-test results and calibrate compass following the steps in App.

Regulatory Notice for Users in EU

Hereby, Fimi declares that the wireless equipment is in compliance with the essential requirements and other relevant provisions of Directive 1999/5/EC.

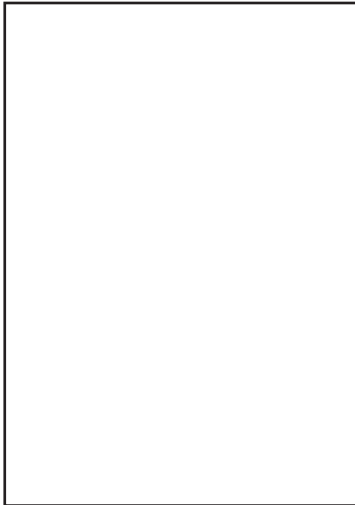

WEEE Disposal and Recycling Information



Correct Disposal of this product. This marking indicates that this product should not be disposal with other household wastes throughout the EU. To prevent possible harm to the environment or human health from uncontrolled waste disposal, recycle it responsibly to promote the sustainable reuse of material resources. To return your used device, please use the return and collection systems or contact the retailer where the product was purchased. They can take this product for environmental safe recycling.

Federal Communications Commission Declaration of Conformity

This equipment has been tested and found to comply with the limits for a Class B digital device, pursuant to Part 15 of the FCC Rules. These limits are designed to provide reasonable protection against harmful interference in a residential installation. This equipment generates, uses, and can radiate radio frequency energy and, if not installed and used in accordance with the instructions, may cause harmful interference to radio communications. However, there is no guarantee that interference will not occur in a particular installation. If this equipment does cause harmful interference to radio or television reception, which can be determined by turning the equipment off and on, the user is encouraged to try to correct the interference by one or more of the following measures:

- Reorient or relocate the receiving antenna.
- Increase the separation between the equipment and receiver.
- Connect the equipment into an outlet on a circuit different from that to which the receiver is connected.
- Consult an authorized dealer or service representative for help.

Fimi is not responsible for any radio or television interference caused by using other than specified or recommended cables and connectors or by unauthorized changes or modifications to this equipment. Unauthorized changes or modifications could void the user's authority to operate the equipment.

This device complies with Part 15 of the FCC Rules. Operation is subject to the following two conditions: (1) this device may not cause harmful interference, and (2) this device must accept any interference received, including interference that may cause undesired operation.

Responsible Party:



Regulatory Notice for Users in USA

USA — Federal Communications Commission (FCC)

This device are granted with following FCC ID by Federal Communications Commission (FCC)

FCC ID: 2AG53YTXJ01FM Name: Integrated Gimbal Camera Model: YTXJ01FM

FCC ID: 2AG53FXQ01FM Name: Mi Drone Model: FXQ01FM

FCC ID: 2AG53YKQ01FM Name: Radio Controller Model: YKQ01FM

RF exposure warning

■ This equipment must be installed and operated in accordance with provided instructions and the antenna(s) used for this transmitter must be installed to provide a separation distance of at least 20 cm from all persons and must not be co-located or operating in conjunction with any other antenna or transmitter. End-users and installers must be provide with antenna installation instructions and transmitter operating conditions for satisfying RF exposure compliance.

Industry Canada Class B Emission Compliance Statement

This Class B digital apparatus complies with Canadian ICES-003.

Cet appareil numérique de la classe B est conforme à la norme NMB-003 du Canada.

Regulatory Notice for Users in Canada

This device are granted with following IC ID by Industry Canada (IC)

IC: 21054-YTXJ01FM Name: Integrated Gimbal Camera Model: YTXJ01FM

IC: 21054-FXQ01FM Name: Mi Drone Model: FXQ01FM

IC: 21054-YKQ01FM Name: Radio Controller Model: YKQ01FM

IC Statement

This device complies with Industry Canada licence-exempt RSS standard(s). Operation is subject to the following two conditions: (1) this device may not cause interference, and (2) this device must accept any interference, including interference that may cause undesired operation of the device.

Le présent appareil est conforme aux CNR d'Industrie Canada applicables aux appareils radio exempts de licence. L'exploitation est autorisée aux deux conditions suivantes : (1) l'appareil ne doit pas produire de brouillage, et (2) l'utilisateur de l'appareil doit accepter tout brouillage radioélectrique subi, même si le brouillage est susceptible d'en compromettre le fonctionnement.

IC RF Exposure statement

This equipment complies with IC radiation exposure limits set forth for an uncontrolled environment.

This equipment should be installed and operated with minimum distance 20cm between the radiator & your body.

Déclaration d'exposition aux radiations:

Cet équipement est conforme aux limites d'exposition aux rayonnements IC établies pour un environnement non contrôlé. Cet équipement doit être installé et utilisé avec un minimum de 20 cm de distance entre la source de rayonnement et votre corps.