

# Bluetooth Module

## WiSe 1220 Hardware and Technical Specification

Preliminary Version (Rev 1.1)

Issued: 21/06/2017

## Table of Contents

General Information .....	4
Features .....	4
General Description .....	4
Block Diagram: .....	4
Application: .....	5
Form factor: .....	5
Hardware Specification:.....	5
Electrical characteristics.....	5
Absolute Maximum Ratings .....	5
Recommended operating condition .....	6
PWM .....	6
Current Consumption: .....	6
RF Characteristics:.....	6
Pinout and Pin Description .....	7
Pinout Diagram .....	7
Recommended Land Pattern: .....	9
Host details: .....	9
Remote.....	9
Smart lighting device.....	9
Best practices.....	10

### Revision History

<b>Rev No</b>	<b>Date</b>	<b>Notes</b>
Rev 1.0	07/12/2016	Draft Release
Rev1.1	21/06/2017	Block diagram and host part updated.

## General Information

### Features

- Bluetooth v4.2 specification complaint
- Support for Bluetooth 4.2 specification host stack
- 12 MHz and 32.768 kHz clock system
- 32.768 kHz for sleep time
- PWM/GPIO/UART interface
- PCB printed Antenna
- 8 programmable GPIO's
- 512 KB Internal FLASH
- Debug SPI

### General Description

WiSe 1220 enables ultra-low-power connectivity and basic data transfer for applications previously limited by the power consumption, size constraints and complexity of other wireless standards. WiSe 1220 is intended to provide considerably reduced power consumption and cost.

### Block Diagram:

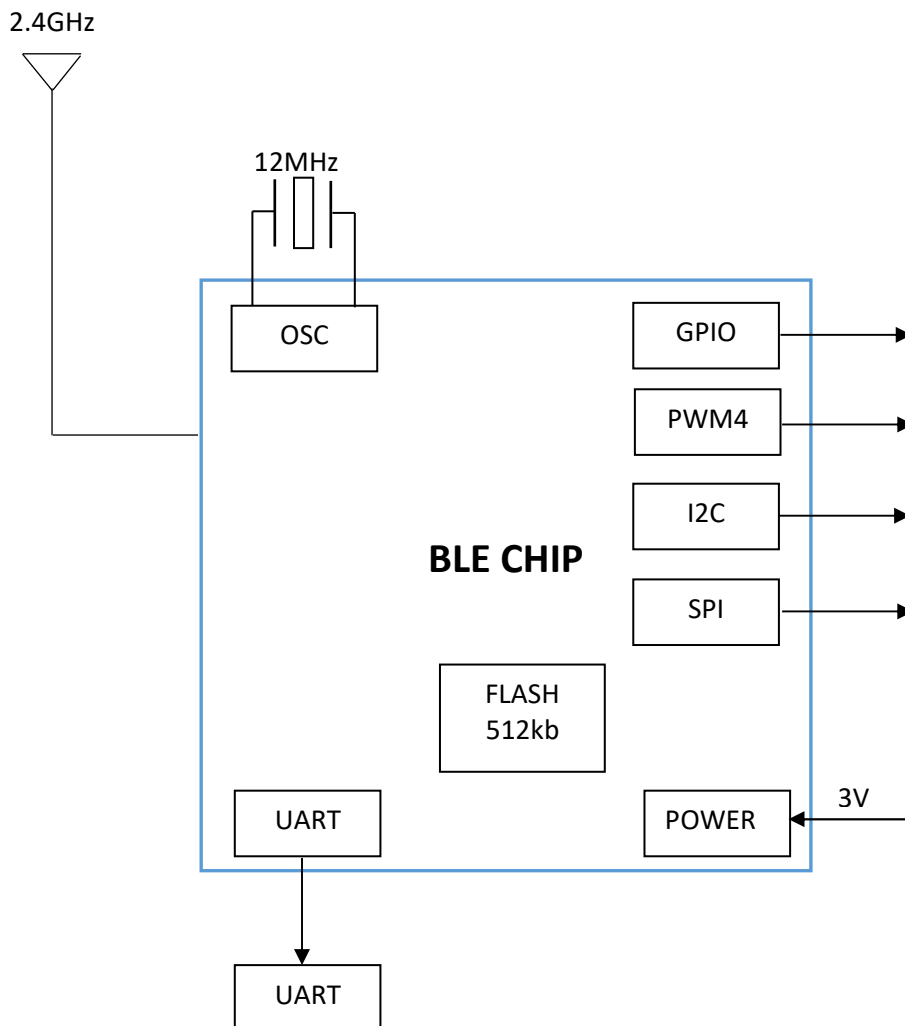

**Application:**

WiSe 1220 enables connectivity and data transfer to leading smartphone, tablet and personal computing devices including Apple iPhone, iPad, iPod and Mac products and leading Android devices.

- Smart mesh light application
- Smart home heating and lighting control
- Health sensors like blood pressure, thermometer and glucose meter
- Beacons
- Security
- Sensors

**Form factor:**

- Dimension: 39.84x8mm

**Hardware Specification:**

COMPONENTS	DESCRIPTION
BLE CHIP	TLSR8269F512AT32
CRYSTAL	12MHz

**Crystal Trim Value and Device ID:**

During the manufacturing process, all WiSe1220 Modules are tested for full RF and DC functionality. This includes measuring crystal frequency error and setting the crystal frequency trim token so the frequency error for an unmodulated RF tone is as close as possible to zero. At this time a unique Bluetooth Device Address is assigned to each module.

**Electrical characteristics**

**Absolute Maximum Ratings**

Ratings	Min	Max
Storage Temperature	-40°C	85°C
Supply voltage	2.6V	3.6V
IO Supply Voltage	V	3.6V
Other Terminal Voltage	Vss - 0.4	Vdd + 0.4V

**Recommended operating condition**

Item	Min	Typical	Max
Storage Temperature	-30	-	85°C
Supply voltage	1.9V	3.3V	3.6V
IO Supply Voltage	V	-	3.6V

**PWM**

Totally there are 4 PWM channels. Any of the IO's can be configured as PWM.

PWM Frequency: Target frequency 40 kHz.  
 Maximum voltage for logic low:  $V_{IL} = 0\text{ V}$   
 Absolute maximum current sourced:  $I_{MAX} = \text{mA}$   
 Absolute maximum voltage level:  $V_{Max} = 3.6\text{V}$

**Current Consumption:**

Mode	Total Typical Current at 3V
Sleep Mode	6µA
RX/TX active	~15mA @ 3.3V peak current

**RF Characteristics:**

Path	Description	Conditions	Min	Typ	Max	Unit
	Operating Frequency		2402		2480	MHz
	Maximum output power			7		dBm
	2 <sup>nd</sup> harmonic				TBD	dBuV
	3 <sup>rd</sup> harmonic				TBD	dBuV
TX	Modulation delta F1 average		TBD	1.3	TBD	MHz
	Modulation delta F1 / F2		0.8			
	Modulation delta F2 max			100		%
	Frequency accuracy		-100	25	100	kHz
	Frequency offset		-100	25	100	kHz
RX	Receiver Sensitivity		-90	-89	-86	dBm
	Receiver Sensitivity (with dirty transmitter)			-92		dBm
	Maximum received signal at 30.8% PER			-10		dBm

## Pinout and Pin Description

### Pinout Diagram

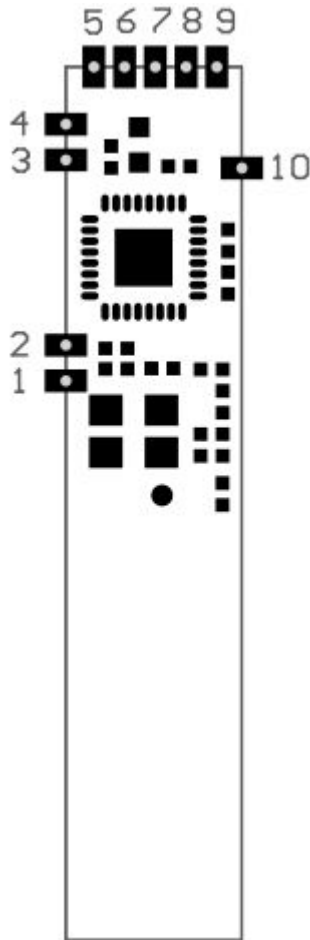

PINS	NAME	FUNCTION	COMMENTS
1	RX	UART	Programmable I/O or RX
2	TX	UART	Programmable I/O or TX
3	GND	Ground	Ground
4	SWS/PWM2	PWM/ Programming pins	Single Wire Interface
5	PWM5	PWM/IO	Programmable I/O
6	PWM4_N	PWM/IO	Programmable I/O
7	PWM4	PWM/IO	Programmable I/O
8	PWM0	PWM/IO	Programmable I/O
9	PWM1	PWM/IO	Programmable I/O
10	VDD	Power	3V3 Input

### Module Dimension

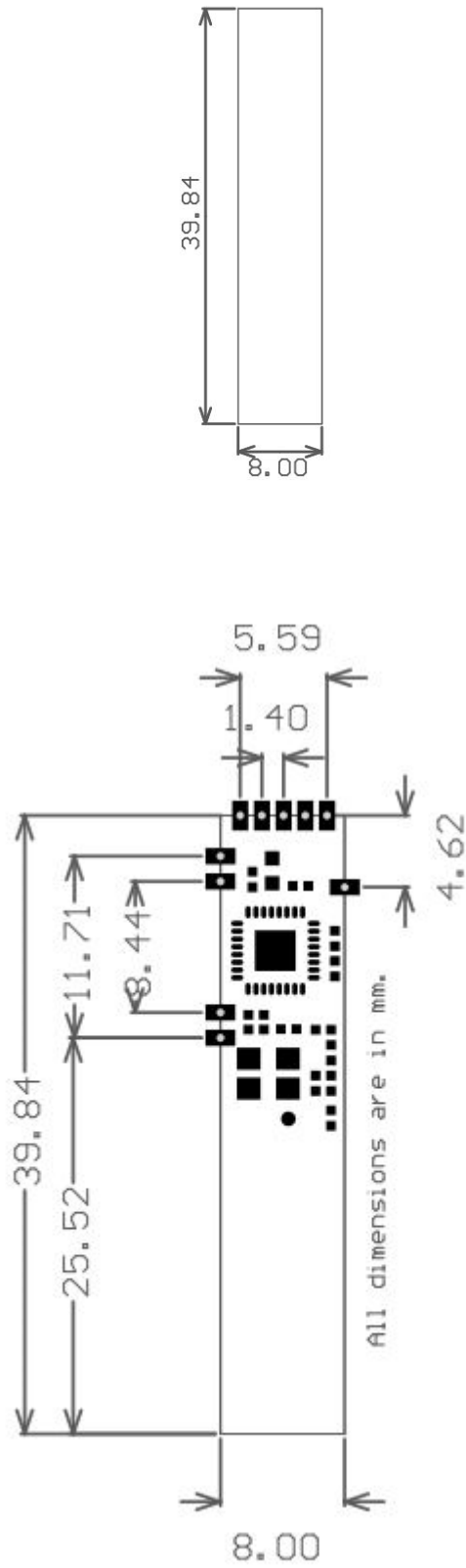



**Recommended Land Pattern:**

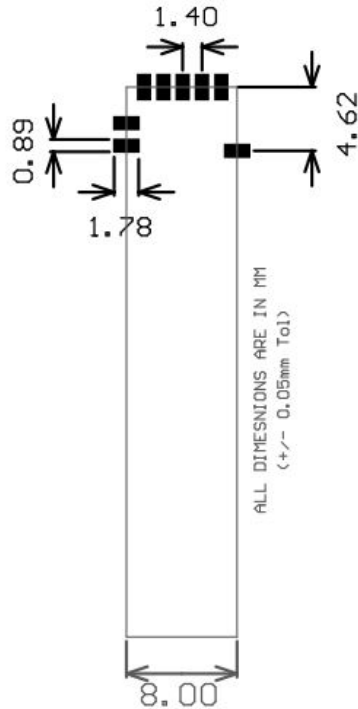

**Host details:**

The WiSe1220 module is going to be embedded with different products like Remote and Smart lighting device.

**Remote**

Remote is used to send the trigger command to the heater or the device associated with that. It is intended to be a general purpose remote control. Also this device is the 2 x AA battery powered.

**Smart lighting device**

The smart lighting device not only controls lighting, it creates a smart mesh which also can be used to track personnel, assets, patients, anything that is equipped with or wearing a WiSilica BLE Tag. There is a tremendous amount of possibilities when you think about security, Workflow management, inventory management, and whole building automation. Also this device is 110 to 230V AC powered.

## Best practices

When designing with WiSe1220 modules, please pay attention to the following recommendations

- While integrating module make sure all the module pads are soldered properly.
- The module's voltage requirement is 2.5 to 3.6V, if the power supply is over 3.3V, please use a voltage regulator.
- If the communicating host uses a different voltage than the BLE module, please make sure that the voltage matches on the communication ports.
- For best wireless signals, please avoid packing the antenna area close to metal parts or case.

## FCC Statement

This device complies with part 15 of the FCC rules. Operation is subject to the following two conditions: (1) this device may not cause harmful interference, and (2) this device must accept any interference received, including interference that may cause undesired operation.

Changes or modifications not expressly approved by the party responsible for compliance could void the user's authority to operate the equipment.

NOTE: This equipment has been tested and found to comply with the limits for a Class B digital device, pursuant to part 15 of the FCC Rules. These limits are designed to provide reasonable protection against harmful interference in a residential installation. This equipment generates uses and can radiate radio frequency energy and, if not installed and used in accordance with the instructions, may cause harmful interference to radio communications. However, there is no guarantee that interference will not occur in a particular installation. If this equipment does cause harmful interference to radio or television reception, which can be determined by turning the equipment off and on, the user is encouraged to try to correct the interference by one or more of the following measures:

- Reorient or relocate the receiving antenna.
- Reorient or relocate the receiving antenna.
- Reorient or relocate the receiving antenna.
- Consult the dealer or an experienced radio/TV technician for help important announcement

Important Note:

## Radiation Exposure Statement

This equipment complies with FCC radiation exposure limits set forth for an uncontrolled environment.

### Important Note:

In the event that these conditions cannot be met (for example certain laptop configurations or co-location with another transmitter), then the FCC authorization is no longer considered valid and the FCC ID cannot be used on the final product. In these circumstances, the OEM integrator will be responsible for re-evaluating the end product (including the transmitter) and obtaining a separate FCC authorization.

## End Product Labeling

The final end product must be labeled in a visible area with the following " Contains FCC ID: 2AG4 NWISE1220 ".

## Manual Information to the End User

The OEM integrator has to be aware not to provide information to the end user regarding how to install or remove this RF module in the user's manual of the end product which integrates this module. The end user manual shall include all required regulatory information/warning as show in this manual.