

# Omni TED

Trailing edge dimmer



## PRODUCT OVERVIEW

Omni TED is a BLE5.2 controllable, trailing edge dimmer. It operates on 90–277VAC input voltage range and can work with single LED loads of up to 250W and has output to connect a switch. It also comes with an optional push button switch input to control the dimming and ON/OFF of the connected load.

The device is a part of the Lumos Controls ecosystem, including controllers, sensors, switches, modules, drivers, gateways, and analytical dashboards. It can be easily commissioned, configured and controlled from any mobile device and can be connected to Lumos Controls cloud for data analytics and configuration management. The ecosystem is listed by the **Design Lights Consortium (DLC)**, qualifying it for energy conservation incentive programs and rebates by utility companies.

## SPECIFICATIONS

### Electrical

Specifications	Value	Remarks
Input voltage	90–277VAC	Rated input voltage
Supply frequency	50–60Hz	
Inrush current protection	75A	
Surge transient protection	4kV	L-N, Bi wave
Dimming operation mode	Trailing edge	
Max output power	250W	250W @277VAC; 125W @90VAC
Min power requirement	None	Active power

## FEATURES

- BLE5.2 based non-flooding intelligent communication
- 1 channel output, up to 250W
- Supports resistive and capacitive loads
- Optional push button switch input to control the dimming and ON/OFF of the connected load
- Compact form factor for easy installation
- Zero downtime Over-The-Air (OTA) firmware updates

### Bluetooth

Specifications	Value	Remarks
Frequency range	2402–2480MHz	
Rx sensitivity	–95dBm	
Connection distance (device to device by mesh)	45m(147.6ft)	In an open office environment (Line of Sight)

### Environmental

Specifications	Value
Operating temperature	–20 to 50°C (–4 to 122°F)
Storage temperature	–40 to 80 °C (–40 to 176°F)
Relative humidity	85%

### Mechanical

Specifications	Value	Remarks
Dimension	45.1 x 35.1 x 20.2mm (1.7 x 1.4 x 0.8in)	L x W x H
Weight	120g(4.23oz)	
Case material	ABS Plastic	
Flammability rating	UL 94 V-0	

## PRODUCT DIMENSIONS

Omni TED top view: 45.1 x 35.1 x 20.2mm (1.7 x 1.4 x 0.8 in) (L x W x H)

Case material: V0 flammability rated ABS plastic

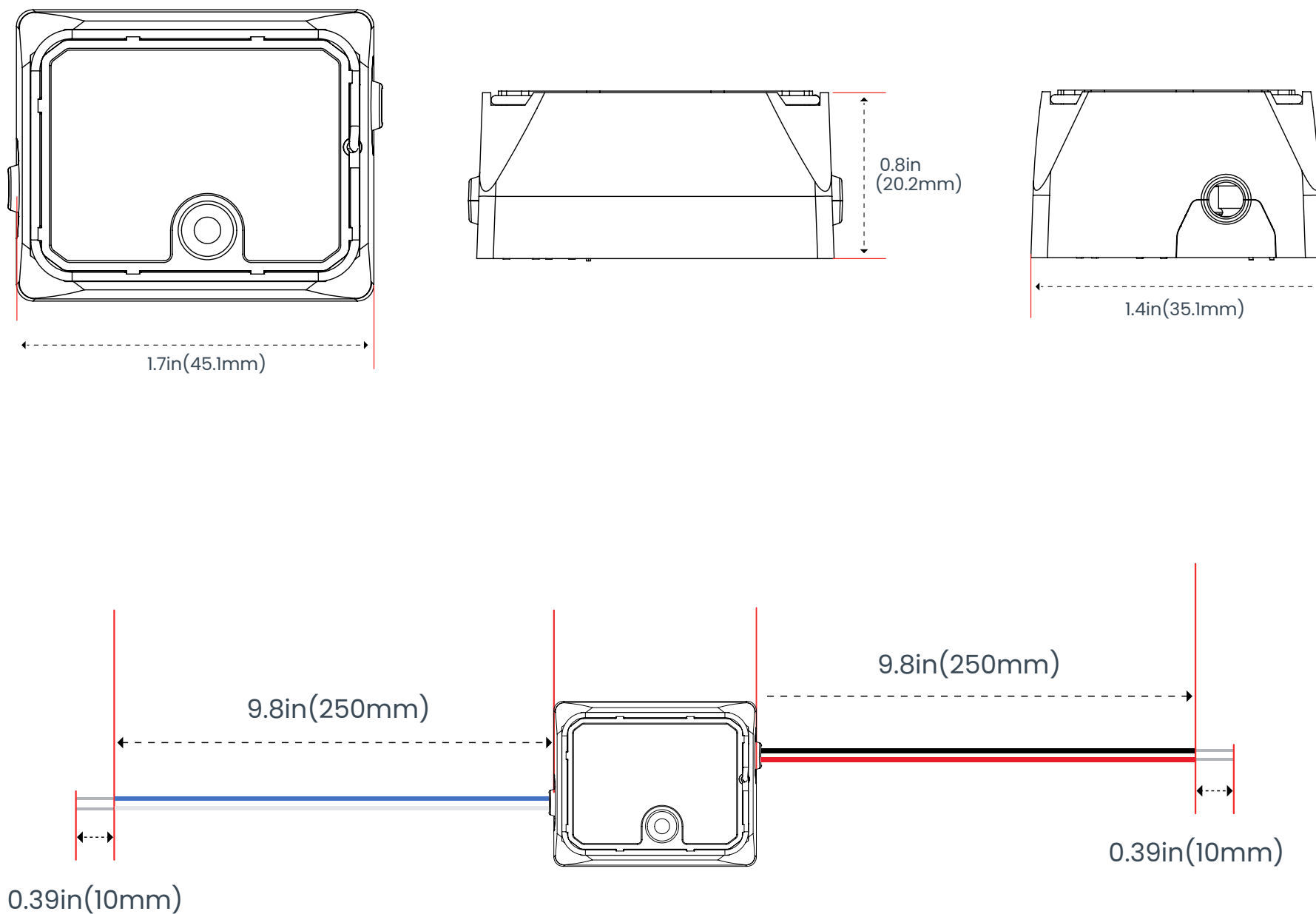

## Size comparison with a standard credit card

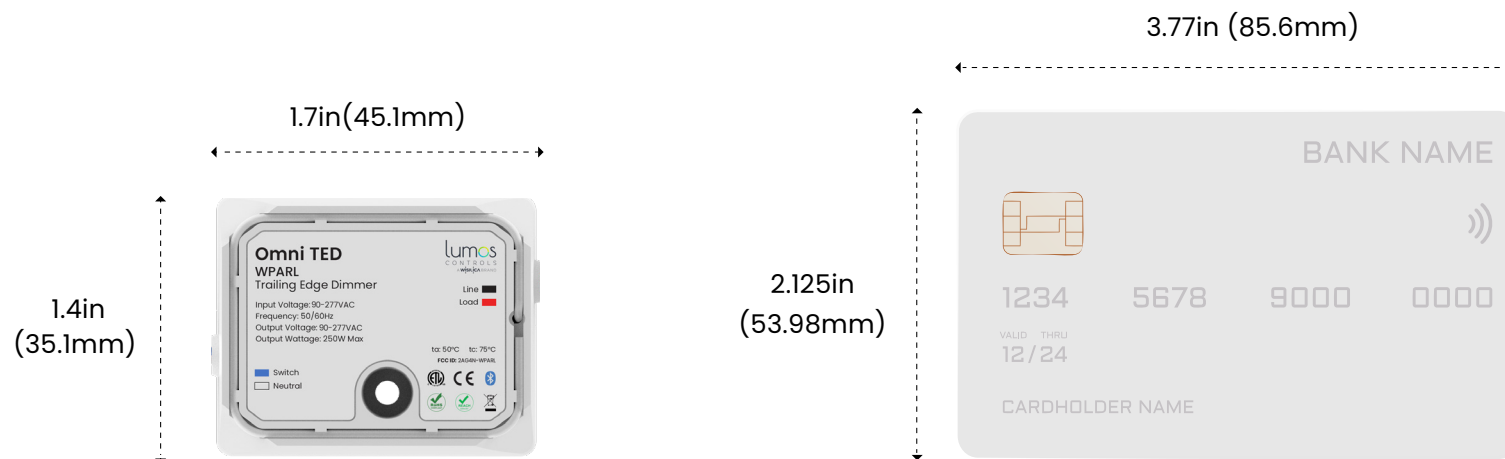

## WIRE DESCRIPTION

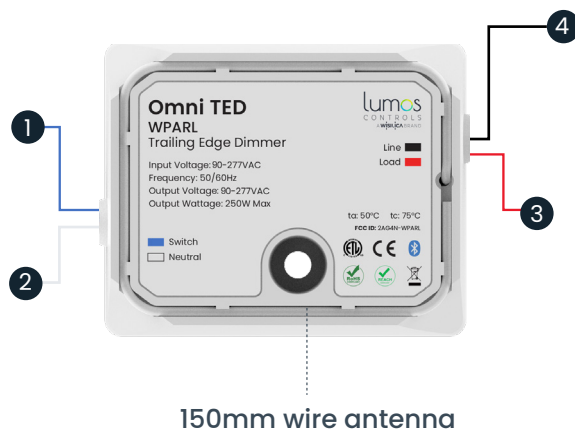

Pin	Name	Color	Gauge	Rating	Description
1	Switch	Blue	18AWG (0.75mm <sup>2</sup> )	600V	To connect switch control
2	Neutral	White	18AWG (0.75mm <sup>2</sup> )	600V	Common neutral
3	Load	Red	18AWG (0.75mm <sup>2</sup> )	600V	For load
4	Line	Black	18AWG (0.75mm <sup>2</sup> )	600V	90-277VAC

## ANTENNA INFORMATION

150mm wire antenna

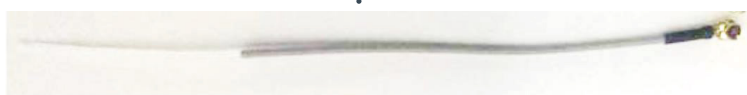

Antenna Properties	
Frequency range	2.4GHz-2.5GHz
Impedance	50Ω Nominal
VSWR	1.92:1 Max
Return loss	-10dB Max
Gain(peak)	1.97dBi
Cable loss	0.3dBi Max
Polarization	Linear

# WIRING

## 1. Controlling Omni Ted using Lumos Controls app

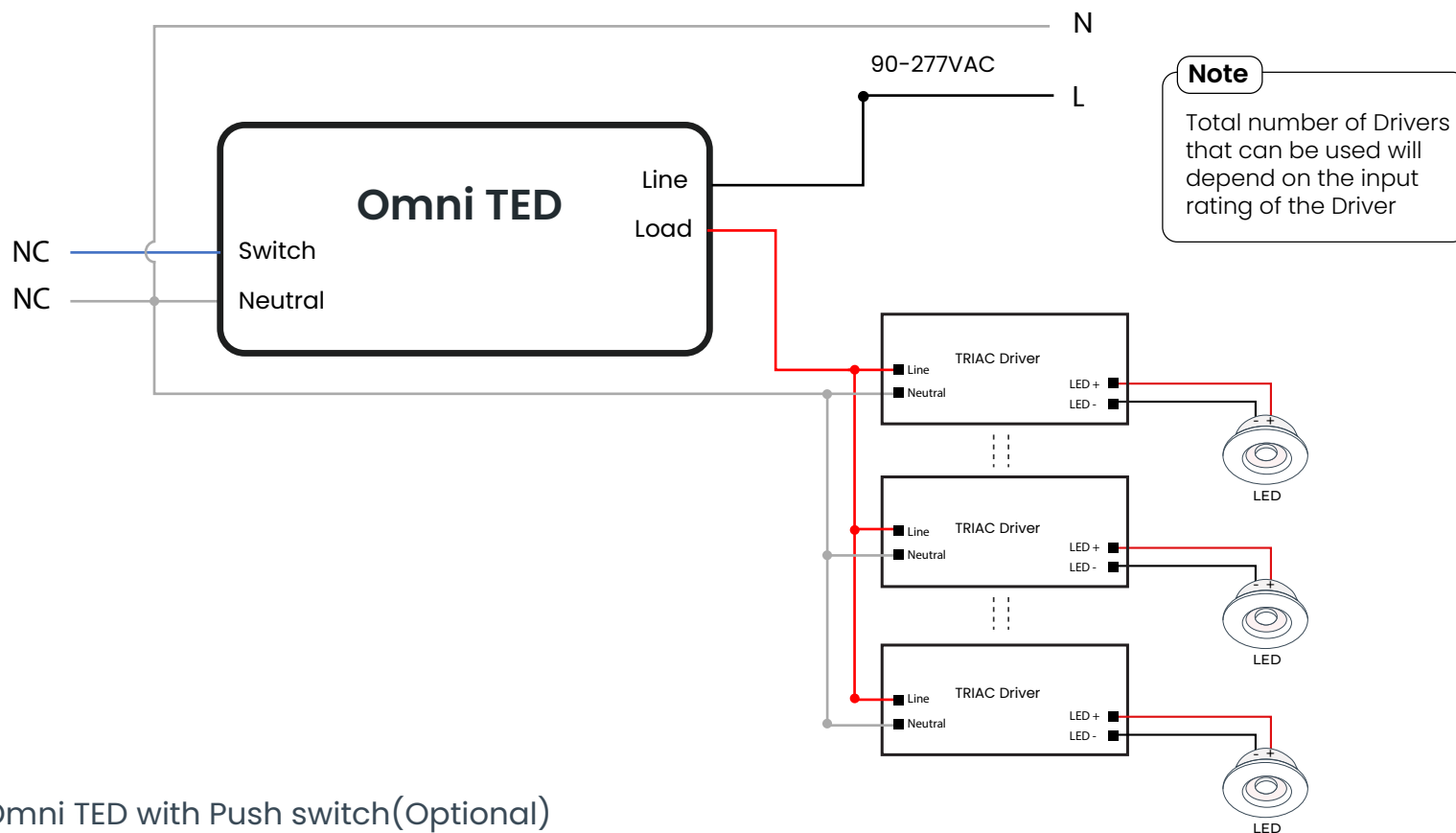

## 2. Configuring Omni TED with Push switch(Optional)

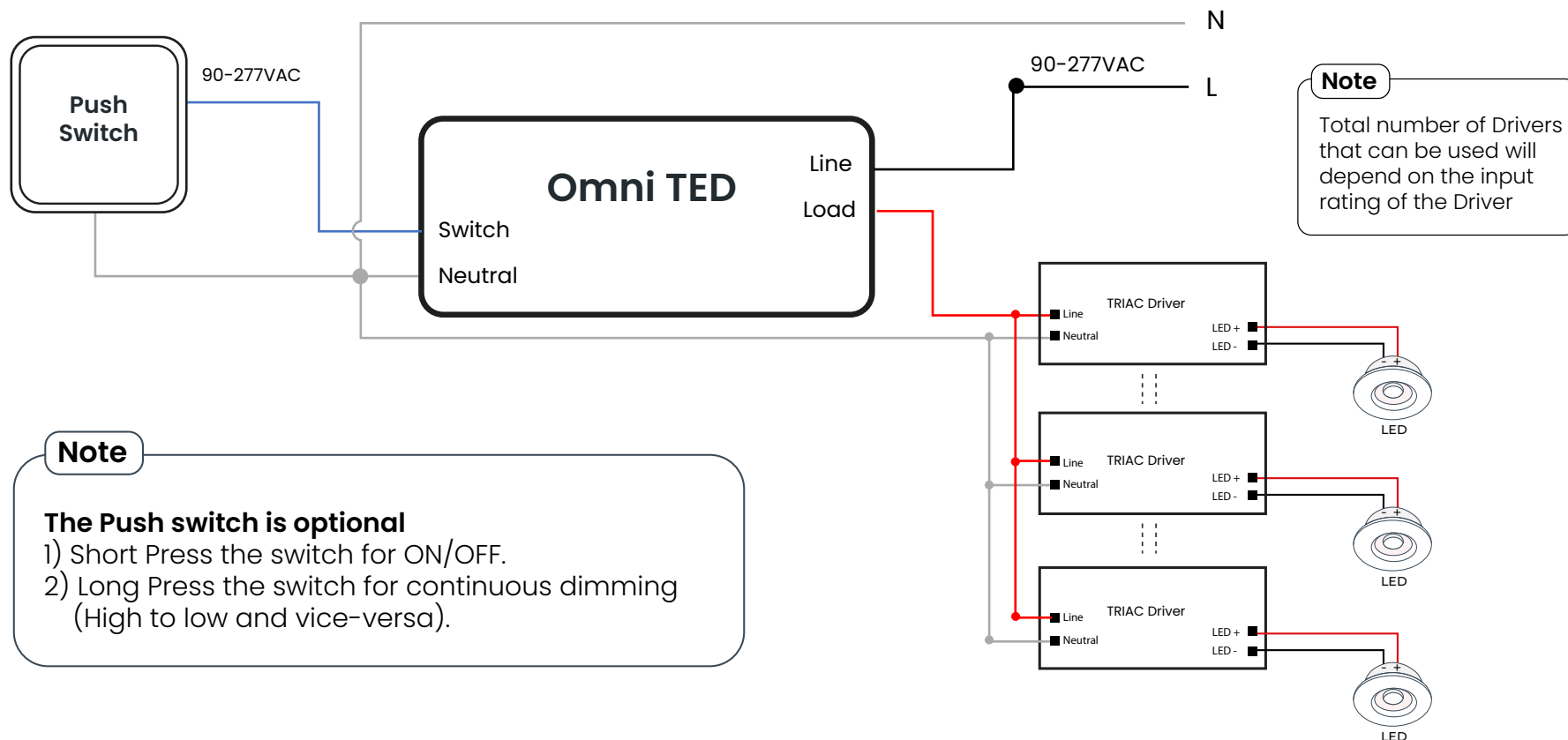

### Note

#### The Push switch is optional

- 1) Short Press the switch for ON/OFF.
- 2) Long Press the switch for continuous dimming (High to low and vice-versa).

# SMART ECOSYSTEM

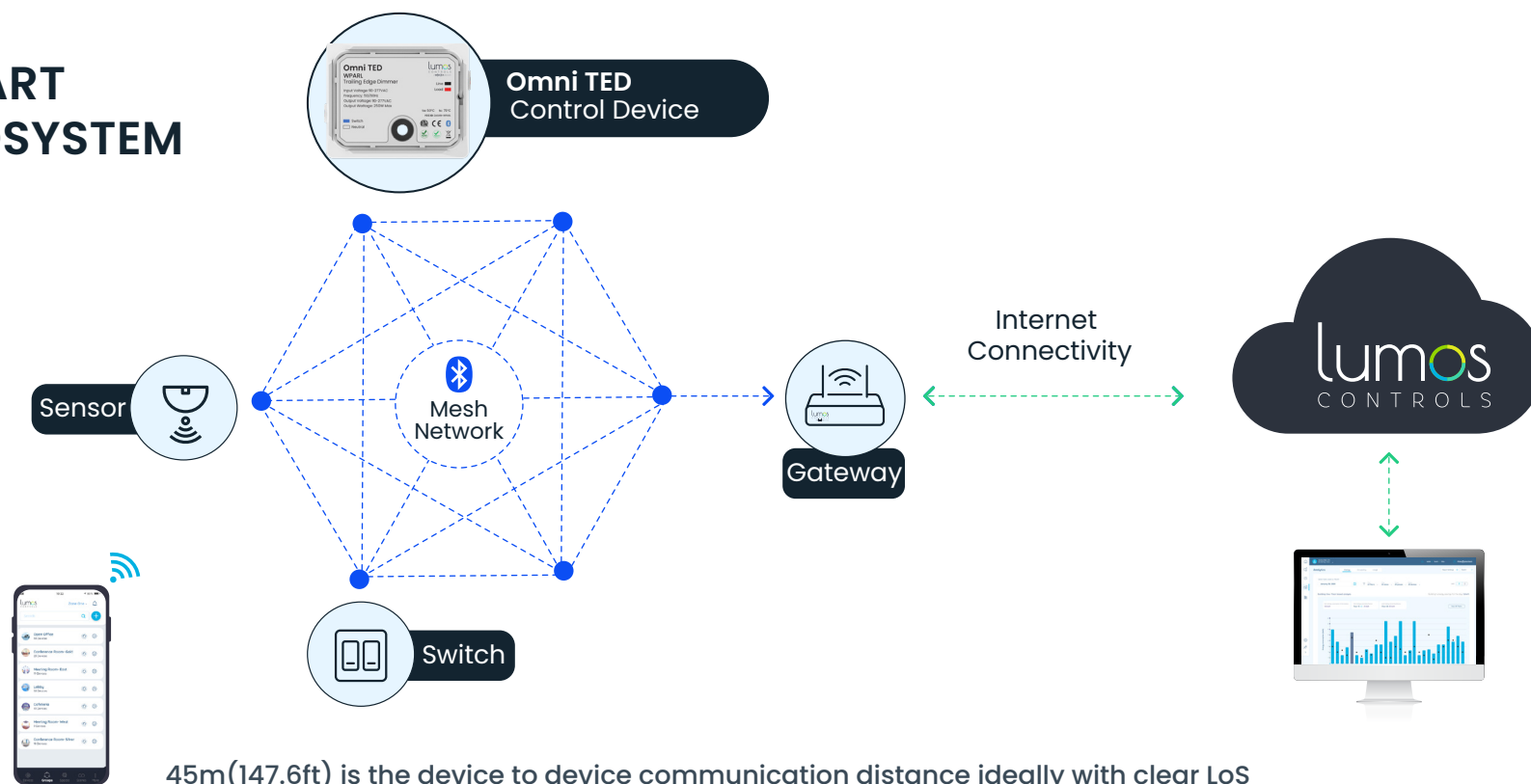

Certifications (in progress)	Details
<b>CE</b>	Article 3, RED 2014/53/EU EMC test standards Safety test standard Radio test standard Health test standard
<b>RoHS 2.0</b>	RoHS Directive (EU) 2015/863 amending Annex II to Directive 2011/65/EU
<b>REACH</b>	Regulation (EC) No 1907/2006 of REACH
<b>WEEE</b>	Under the WEEE Directive: 2012/19/EU
<b>Bluetooth</b>	Declaration ID: D059551
<b>cETLus</b>	Standard: UL 60730-1
<b>FCC</b>	ID: 2AG4N-WPARL

## APPLICATION



## ITEMS INCLUDED IN THE PACKAGE BOX

- Omni TED
- User manual
- Screw
- Wallplug
- Wirenut

## ORDERING INFORMATION

Product Code	Product Name	Product Description	Communication	Voltage Rating	Load Rating
WPARL	Omni TED	Trailing edge dimmer	BLE5.2	90-277VAC	Up to 250W

The Bluetooth® word mark and logos are registered trademarks owned by Bluetooth SIG, Inc. and any use of such marks by WiSilica Inc. is under license. Other trademarks and trade names are those of their respective owners.



20321 Lake Forest Dr D6,  
Lake Forest, CA 92630

[www.lumoscontrols.com](http://www.lumoscontrols.com)

+1 949-397-9330

FCC Caution:

This device complies with part 15 of the FCC Rules. Operation is subject to the following two conditions: (1) this device may not cause harmful interference, and (2) this device must accept any interference received, including interference that may cause undesired operation.

Any changes or modifications not expressly approved by the party responsible for compliance could void the user's authority to operate the equipment.

NOTE: This equipment has been tested and found to comply with the limits for a Class B digital device, pursuant to Part 15 of the FCC Rules. These limits are designed to provide reasonable protection against harmful interference in a residential installation. This equipment generates, uses and can radiate radio frequency energy and, if not installed and used in accordance with the instructions, may cause harmful interference to radio communications. However, there is no guarantee that interference will not occur in a particular installation. If this equipment does cause harmful interference to radio or television reception, which can be determined by turning the equipment off and on, the user is encouraged to try to correct the interference by one or more of the following measures:

- Reorient or relocate the receiving antenna.
- Increase the separation between the equipment and receiver.
- Connect the equipment into an outlet on a circuit different from that to which the receiver is connected.
- Consult the dealer or an experienced radio/TV technician for help.

To maintain compliance with FCC's RF Exposure guidelines, This equipment should be installed and operated with minimum distance between 20cm the radiator your body: Use only the supplied antenna.

FCC ID: 2AG4N-WPARL