

# Senor E

Senor E is a bi-directional communication device that can be positioned at various locations throughout the BLE Mesh network to extend the coverage. This USB powered wireless BLE5.2 based device also supports beacons and comes with different antenna options for better communication.



## Table of Contents

1.	Features.....	3
2.	Specifications .....	3
3.	Device Dimensions.....	4
4.	Antenna.....	4
5.	Use Cases.....	6
6.	Installation .....	7
7.	Certifications.....	7
8.	Warning.....	7
9.	Ordering Information.....	7

## 1. Features

- Increases the WiSilica BLE Mesh network range
- Act as a Mesh device to relay messages between far devices
- Support iBeacon, Eddystone beacon, Eddystone beacon URL, Alt beacon, and Custom beacon
- Antenna options for better wireless communication
- Unit powered by a USB type A adapter
- Zero downtime Over-the-Air (OTA) firmware updates

## 2. Specifications

Electrical	Min.	Typ.	Max.	Unit	Remarks
Input voltage		5		V	USB Type-A
Input current	10	15	33	mA	

Bluetooth	Min.	Typ.	Max.	Unit	Remarks
Frequency Range	2402		2480	MHz	
TX Output Power			<b>2.31</b>	dBm	Conductive
RX sensitivity		-92		dBm	@1Mbps

Environmental	Min.	Typ.	Max.	Unit	Remarks
Operating Temperature	0		50	°C	
Relative Humidity	20		85	%	Non-condensing application only

Mechanical	Min.	Typ.	Max.	Unit	Remarks
Dimensions		66.7 x 29.2 x 22.4		mm	L x W x H
Dimensions		2.6 x 1.15 x 0.9		in	L x W x H
Mounting	Wall/Surface mounting				

### 3. Device Dimensions

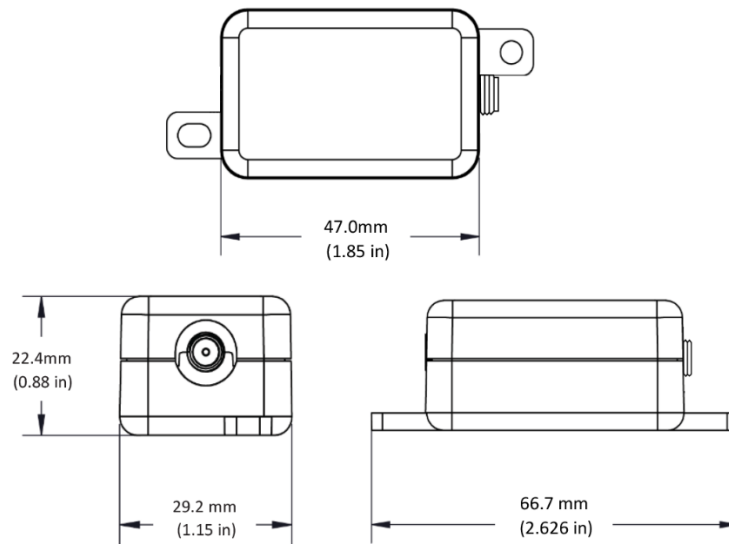

### 4. Antenna

Stick antenna



Stick antenna

Antenna Properties	
Frequency range	2.4GHz-2.5GHz
Impedance	50Ω
VSWR	≤ 1.8
Return loss	≥12dB
Gain (Peak)	2dBi
Power handling	10W
Polarization	Vertical
Radiation pattern	Omni-directional

600mm wire antenna



Wire antenna

Antenna Properties	
Frequency range	2.4 GHz-2.5GHz
Impedance	50 $\Omega$ Nominal
VSWR	1.92:1 Max
Return loss	-10 dB Max
Gain(peak)	2dBi
Cable loss	0.3dBi Max
Polarization	Linear vertical

130mm wire antenna



Wire antenna

Antenna Properties	
Frequency range	2.4 GHz-2.5GHz
Impedance	50 $\Omega$ Nominal
VSWR	1.92:1 Max
Return loss	-10 dB Max
Gain(peak)	2dBi
Cable loss	0.3dBi Max
Polarization	Linear vertical

2. Device as a BLE beacon transmitter

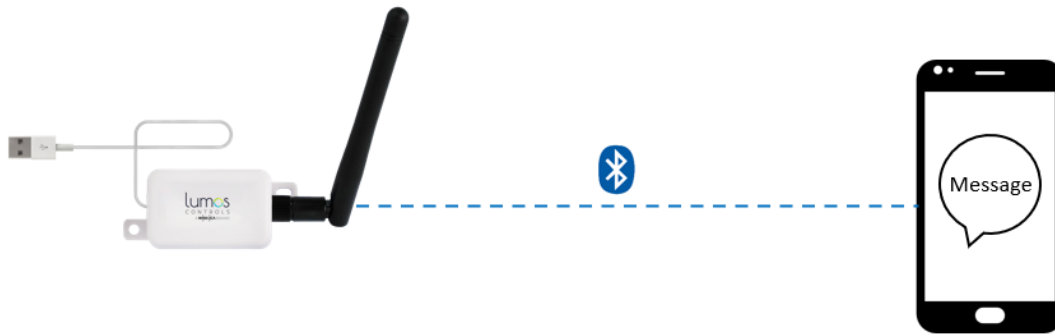

## 6. Installation

1. Find the position to place the repeater between the WiSilica Bluetooth devices
2. Put the hole on the wall or surface where this repeater needs to be installed
3. Screw the repeater on the wall/surface via the mounting flanges on the device
4. Connect the USB port to the \*power adapter
5. Plug in the adapter and power-on the repeater device

\*Sold as separate accessory along with the product

## 7. Certifications



## 8. Warning

1. To prevent the device from any defect, please handle and store it with care.
2. Do not store in very humid location or at extreme temperature.
3. Do not open or disassemble the product.
4. Do not expose this apparatus to rain or moisture. The apparatus shall not be exposed to dripping or splashing and that objects filled with liquids, such as vases, shall not be placed on apparatus.

## 9. Ordering Information

Product Code	Product Name	Product Description	Antenna	Communication	Voltage Rating
WLUNE	Senor E	Beacon and Range Extender	External antenna	BLE5.2	5V, USB type-A
WLUNC	Senor E	Beacon and Range Extender	Chip antenna	BLE5.2	5V, USB type-A

#### FCC Statement

This equipment has been tested and found to comply with the limits for a Class B digital device, pursuant to part 15 of the FCC Rules. These limits are designed to provide reasonable protection against harmful interference in a residential installation. This equipment generates, uses and can radiate radio frequency energy and, if not installed and used in accordance with the instructions, may cause harmful interference to radio communications. However, there is no guarantee that interference will not occur in a particular installation. If this equipment does cause harmful interference to radio or television reception, which can be determined by turning the equipment off and on, the user is encouraged to try to correct the interference by one or more of the following measures:

- Reorient or relocate the receiving antenna.
- Increase the separation between the equipment and receiver.
- Connect the equipment into an outlet on a circuit different from that to which the receiver is connected.
- Consult the dealer or an experienced radio/TV technician for help.

Caution: Any changes or modifications to this device not explicitly approved by manufacturer could void your authority to operate this equipment.

This device complies with part 15 of the FCC Rules. Operation is subject to the following two conditions: (1) This device may not cause harmful interference, and (2) this device must accept any interference received, including interference that may cause undesired operation.

#### RF Exposure Information

The device has been evaluated to meet general RF exposure requirement. The device can be used in portable exposure condition without restriction.



CONNECTING THINGS TO LIFE

Wisilica Inc  
23282 Mill Creek Dr #340, Laguna Hills, CA 92653  
United States of America

[info@wisilica.com](mailto:info@wisilica.com) [www.wisilica.com](http://www.wisilica.com)

Version 1.1