



WC-D-2CH0010V

Wireless Controlled 0-10V Dual Channel Dimming Module

The WiSilica Energy Efficiency line of products are all Bluetooth Low Energy Mesh devices that can be controlled or monitored via mobile device or cloud-based platform.

The 0-10V dimming module is powered by 12-24vdc from the auxiliary power of the LED driver and the 0-10v dimming wires of the dimmable driver connect directly to the dimming module for dual channel wireless dimming control.

WiSilica Mesh devices can be paired wireless with other WiSilica products like the integrated 4 in 1 micro-sensor, wireless remote, occupancy sensors, ambient light sensors, real time clocks and more, giving the building owner tremendous flexibility when optimizing their building to meet energy efficient standards or guidelines.

The WiSilica Dim series not only controls lighting, it creates a smart mesh which also can be used to track personnel, assets, patients, or anything that is equipped with or wearing a WiSilica BLE Tag. There are tremendous possibilities when you think about security, workflow management, inventory management, and whole building automation.

Specifications

Radio Frequency

(BLE 4.2) 2.4-2.5Ghz

Device Security

AES 128k Encryption with
3 level pairing keys (Network, APP, GUID)

Antenna

Integrated Antenna
SMA Connector for External Antenna

Technical Specifications

Operating: 0-70°C
Connector Type: Terminal Connection
Enclosure: ABS Plastic
Input Voltage: 12-24VDC
Input Frequency: 50/60Hz
Dim 1 & 2 Control Input: Push in style 18-24AWG
Dim Control Output: 0-10VDC
Dimensions: 63.4 x 26 x 19.4mm



Block Diagram

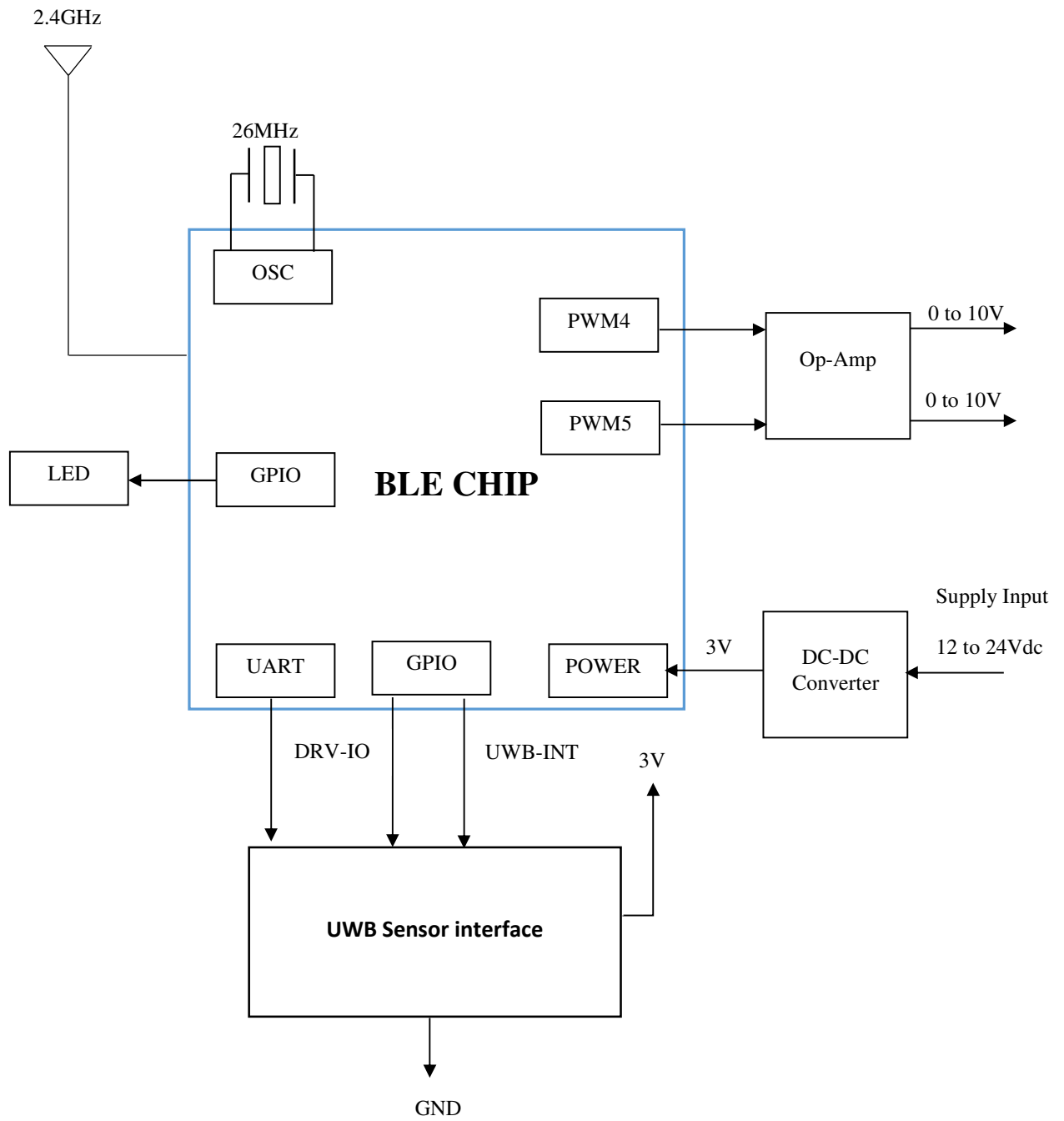

Product Dimensions

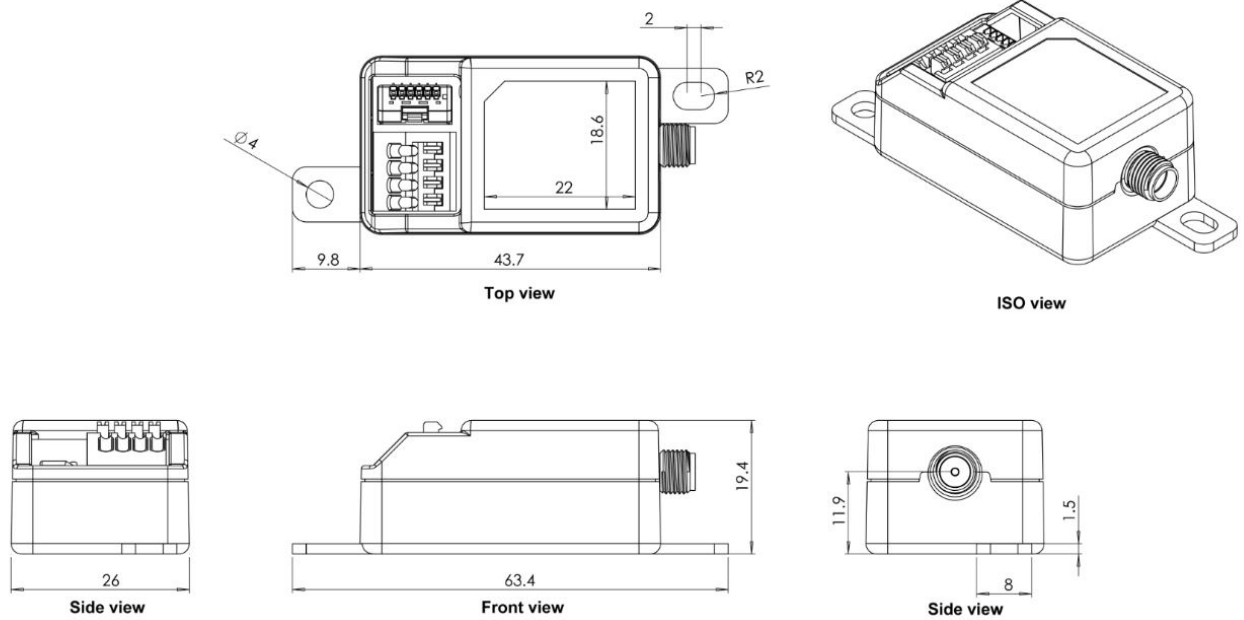

Connector Details

Signal I/O Connector

PIN	SYMBOL	COLOR	DESCRIPTION
1	DRV-IO	Gray	External driver control (PWM or IO)
2	UWB-INTERRUPT	Yellow	Interrupt from UWB sensor
3	RX	Blue	UART
4	TX	White	UART
5	GND	Black	Power input for UWB sensor (negative)
6	VDD33	Red	Power input for UWB sensor (positive)

4 Pin Connector

PIN	SYMBOL	COLOR	DESCRIPTION
1	0-10V 1+	Purple	CH1 0 to 10V Analog dimming positive
2	0-10V 2+	Purple	CH2 0 to 10V Analog dimming positive
3	Vin 12-24V	Yellow	Input power supply positive
4	GND	Gray	Input power supply negative

SLM-D Use cases

1. Controlling Single Dual Color Bulb

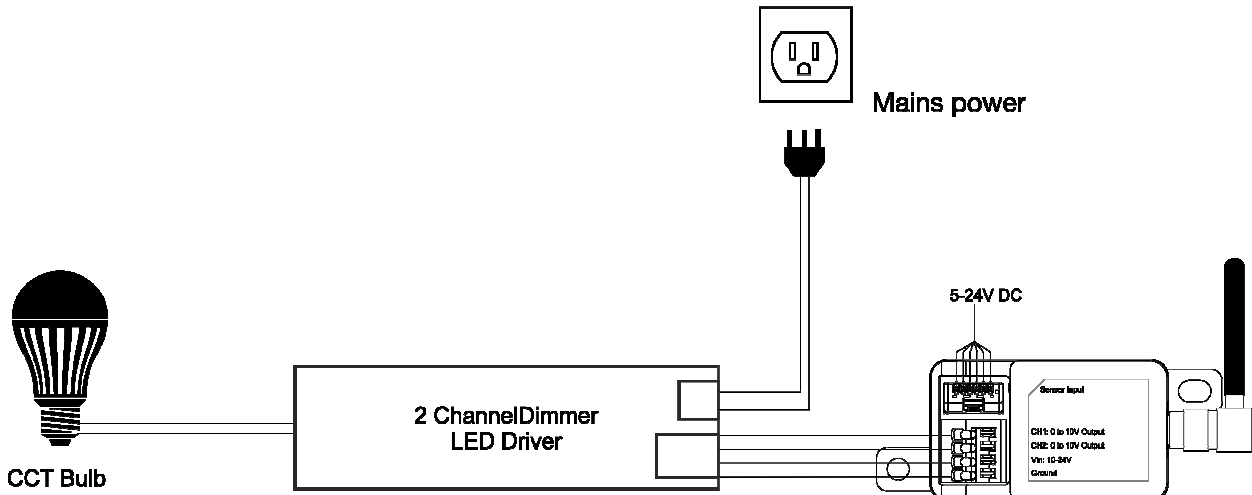

2. Controlling Twin Dual Color Dimmable tube

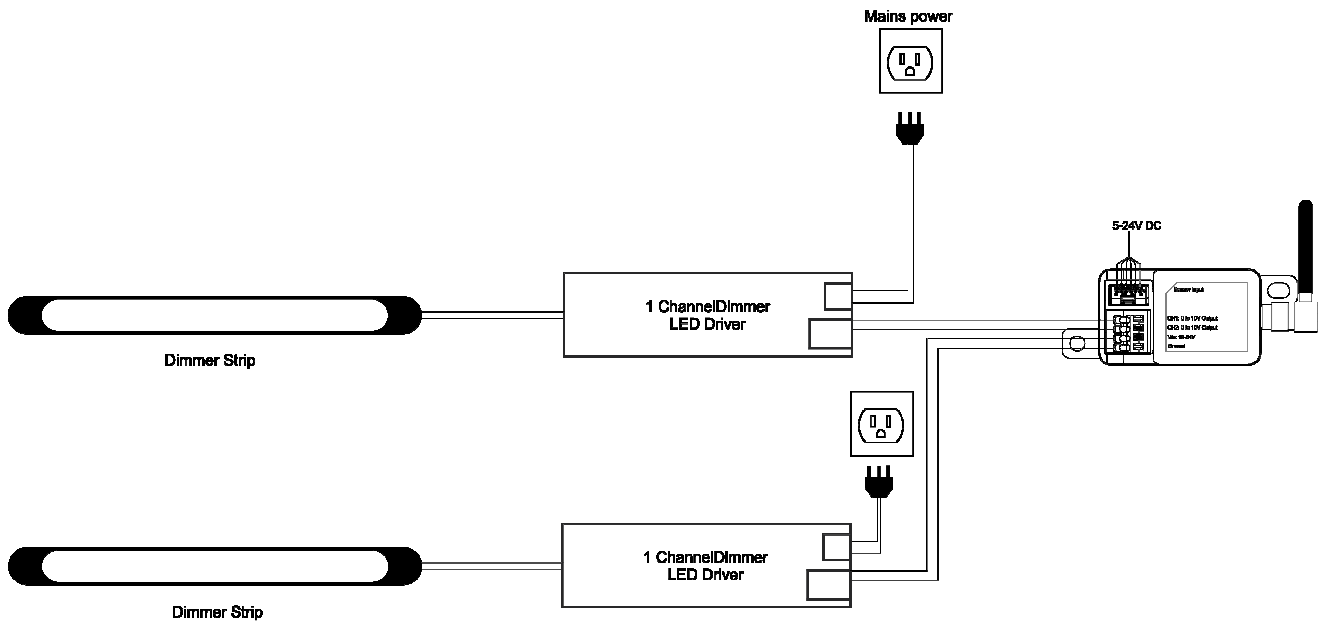

User Precautions

- Observe the correct polarity of output terminal.
- Avoid input voltage exceeding the maximum rating, which may cause damage to the circuit and result in malfunction.
- Static electricity or surge voltage may damage the components inside LED Driver; in order to avoid this please follow the proper anti-electrostatic working process.

FCC Statement

This equipment has been tested and found to comply with the limits for a Class B digital device, pursuant to part 15 of the FCC Rules. These limits are designed to provide reasonable protection against harmful interference in a residential installation. This equipment generates, uses and can radiate radio frequency energy and, if not installed and used in accordance with the instructions, may cause harmful interference to radio communications. However, there is no guarantee that interference will not occur in a particular installation. If this equipment does cause harmful interference to radio or television reception, which can be determined by turning the equipment off and on, the user is encouraged to try to correct the interference by one or more of the following measures:

- Reorient or relocate the receiving antenna.
- Increase the separation between the equipment and receiver.
- Connect the equipment into an outlet on a circuit different from that to which the receiver is connected.
- Consult the dealer or an experienced radio/TV technician for help.

Caution: Any changes or modifications to this device not explicitly approved by manufacturer could void your authority to operate this equipment.

This device complies with part 15 of the FCC Rules. Operation is subject to the following two conditions: (1) This device may not cause harmful interference, and (2) this device must accept any interference received, including interference that may cause undesired operation.

RF Exposure Information

To comply with FCC RF exposure compliance requirements, this grant is applicable to only mobile configurations. The antennas used for this transmitter must be installed to provide a separation distance of at least 20 cm from all persons and must not be co-located or operating in conjunction with any other antenna or transmitter.